

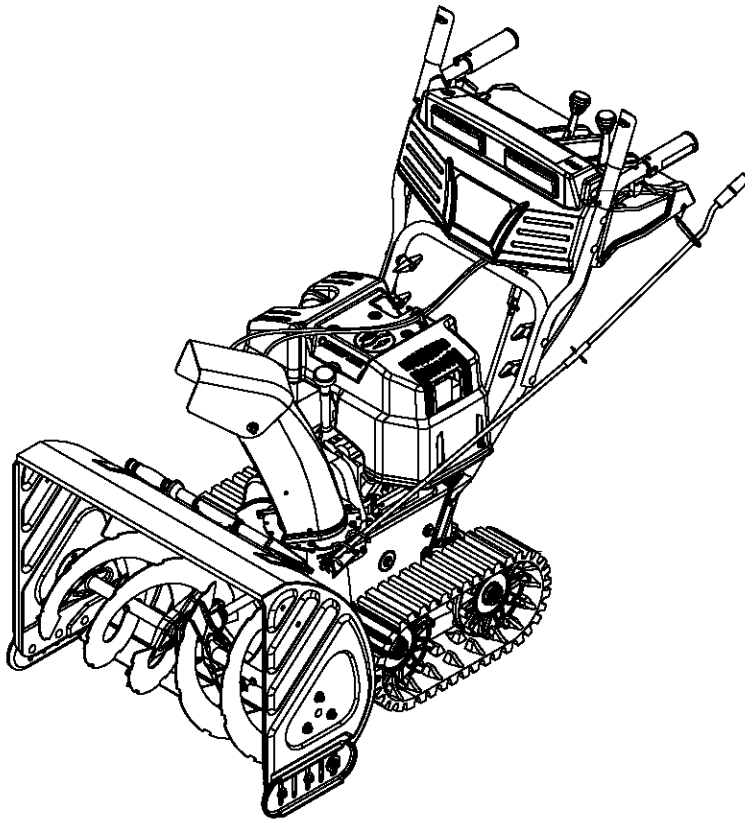

# Operator's Manual



**SNOW THROWER**

**MODEL**

**31AH7T74063**

**Storm Tracker**

## **IMPORTANT: READ SAFETY RULES AND INSTRUCTIONS CAREFULLY**

**WARNING:** This unit is equipped with an internal combustion engine and should not be used on or near any unimproved forest-covered, brush-covered or grass-covered land unless the engine's exhaust system is equipped with a spark arrester meeting applicable local or state laws (if any). If a spark arrester is used, it should be maintained in effective working order by the operator. In the State of California the above is required by law (Section 4442 of the California Public Resources Code). Other states may have similar laws. Federal laws apply on federal lands. A spark arrester for the muffler is available through your nearest engine authorized service dealer or contact the service department, P.O. Box 361131 Cleveland, Ohio 44136-0019.

**TROY-BILT LLC, P.O. BOX 361131 CLEVELAND, OHIO 44136-0019**

PRINTED IN U.S.A.

FORM NO. 769-00395A  
(6/03)

# TABLE OF CONTENTS

Content	Page
Important Safe Operation Practices.....	3
Assembling Your Snow Thrower.....	5
Know Your Snow Thrower .....	6
Operating Your Snow Thrower.....	8
Making Adjustments .....	11
Maintaining Your Snow Thrower.....	12
Service.....	14
Troubleshooting.....	17
Parts List.....	18

## FINDING MODEL NUMBER

This Operator's Manual is an important part of your new snow thrower. It will help you assemble, prepare and maintain the unit for best performance. Please read and understand what it says.



**Before you start assembling your new equipment**, please locate the model plate on the equipment and copy the information from it in the space provided below. The information on the model plate is very important if you need help from your local authorized dealer.

You can locate the model number by looking at the lower frame cover on the rear of your snow thrower. A sample model plate is explained below. For future reference, please copy the model number and the serial number of the equipment in the space below.

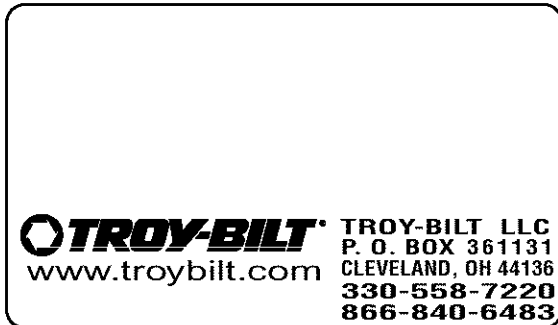

Copy the model number here: \_\_\_\_\_

Copy the serial number here: \_\_\_\_\_

## ENGINE INFORMATION

The engine manufacturer is responsible for all engine-related issues with regards to performance, power-rating, specifications, warranty and service. Please refer to the engine manufacturer's Owner's/Operator's Manual packed separately with your unit for more information.

## CALLING CUSTOMER SUPPORT

**Please do NOT return the unit to the retailer from which it was purchased, without first contacting Customer Support.**

Should you have difficulty assembling this product or have any questions regarding the controls, operation or maintenance of this unit, please call the Customer Support Department.



Call **1- (330) 558-7220** or **1- (866) 840-6483** to reach a Customer Support representative. Please have your unit's model number and serial number ready when you call. See previous section to locate this information. You will be asked to enter the serial number in order to process your call.

For more details about your unit, visit our website at [www.troybilt.com](http://www.troybilt.com)

---

## SECTION 1: IMPORTANT SAFE OPERATION PRACTICES



This symbol points out important safety instructions, which if not followed, could endanger the personal safety and/or property of yourself and others. Read and follow all instructions in this manual before attempting to operate this machine. Failure to comply with these instructions may result in personal injury. When you see this symbol—**heed its warning.**



**WARNING:** Engine Exhaust, some of its constituents, and certain vehicle components contain or emit chemicals known to the State of California to cause cancer, birth defects or other reproductive harm.



**DANGER:** This machine was built to be operated according to the rules for safe operation in this manual. As with any type of power equipment, carelessness or error on the part of the operator can result in serious injury. This machine is capable of amputating hands and feet and throwing objects. Failure to observe the following safety instructions could result in serious injury or death.

### TRAINING

1. Read, understand, and follow all instructions on the machine and in the manual(s) before attempting to assemble and operate. Keep this manual in a safe place for future and regular reference and for ordering replacement parts.
2. Be familiar with all controls and their proper operation. Know how to stop the machine and disengage them quickly.
3. Never allow children under 14 years old to operate this machine. Children 14 years old and over should read and understand the operation instructions and safety rules in this manual and should be trained and supervised by a parent.
4. Never allow adults to operate this machine without proper instruction.
5. Thrown objects can cause serious personal injury. Plan your snow-throwing pattern to avoid discharge of material toward roads, bystanders and the like.
6. Keep bystanders, helpers, pets and children at least 75 feet from the machine while it is in operation. Stop machine if anyone enters the area.
7. Exercise caution to avoid slipping or falling, especially when operating in reverse.
7. Never attempt to make any adjustments while engine is running, except where specifically recommended in the operator's manual.
8. Let engine and machine adjust to outdoor temperature before starting to clear snow.
9. To avoid personal injury or property damage use extreme care in handling gasoline. Gasoline is extremely flammable and the vapors are explosive. Serious personal injury can occur when gasoline is spilled on yourself or your clothes, which can ignite. Wash your skin and change clothes immediately.
  - a. Use only an approved gasoline container.
  - b. Extinguish all cigarettes, cigars, pipes and other sources of ignition.
  - c. Never fuel machine indoors.
  - d. Never remove gas cap or add fuel while the engine is hot or running.
  - e. Allow engine to cool at least two minutes before refueling.
  - f. Never over fill fuel tank. Fill tank to no more than ½ inch below bottom of filler neck to provide space for fuel expansion.
  - g. Replace gasoline cap and tighten securely.
  - h. If gasoline is spilled, wipe it off the engine and equipment. Move machine to another area. Wait 5 minutes before starting the engine.
  - i. Never store the machine or fuel container inside where there is an open flame, spark or pilot light (e.g. furnace, water heater, space heater, clothes dryer etc.).
  - j. Allow machine to cool at least 5 minutes before storing.

### PREPARATION

1. Thoroughly inspect the area where the equipment is to be used. Remove all doormats, newspapers, sleds, boards, wires and other foreign objects, which could be tripped over or thrown by the auger/impeller.
2. Always wear safety glasses or eye shields during operation and while performing an adjustment or repair to protect your eyes. Thrown objects which ricochet can cause serious injury to the eyes.
3. Do not operate without wearing adequate winter outer garments. Do not wear jewelry, long scarves or other loose clothing, which could become entangled in moving parts. Wear footwear which will improve footing on slippery surfaces.
4. Use a grounded three-wire extension cord and receptacle for all units with electric start engines.
5. Adjust collector housing height to clear gravel or crushed rock surfaces.
6. Disengage all clutch levers before starting the engine.

### OPERATION

1. Do not put hands or feet near rotating parts, in the auger/impeller housing or discharge chute. Contact with the rotating parts can amputate hands and feet.
2. The auger/impeller clutch lever is a safety device. Never bypass its operation. Doing so makes the machine unsafe and may cause personal injury.
3. The clutch levers must operate easily in both directions and automatically return to the disengaged position when released.
4. Never operate with a missing or damaged discharge chute. Keep all safety devices in place and working.

5. Never run an engine indoors or in a poorly ventilated area. Engine exhaust contains carbon monoxide, an odorless and deadly gas.
6. Do not operate machine while under the influence of alcohol or drugs.
7. Muffler and engine become hot and can cause a burn. Do not touch.
8. Exercise extreme caution when operating on or crossing gravel surfaces. Stay alert for hidden hazards or traffic.
9. Exercise caution when changing direction and while operating on slopes.
10. Plan your snow-throwing pattern to avoid discharge towards windows, walls, cars etc. Thus, avoiding possible property damage or personal injury caused by a ricochet.
11. Never direct discharge at children, bystanders and pets or allow anyone in front of the machine.
12. Do not overload machine capacity by attempting to clear snow at too fast of a rate.
13. Never operate this machine without good visibility or light. Always be sure of your footing and keep a firm hold on the handles. Walk, never run.
14. Disengage power to the auger/impeller when transporting or not in use.
15. Never operate machine at high transport speeds on slippery surfaces. Look down and behind and use care when in reverse.
16. If the machine should start to vibrate abnormally, stop the engine, disconnect the spark plug wire and ground it against the engine. Inspect thoroughly for damage. Repair any damage before starting and operating.
17. Disengage all clutch levers and stop engine before you leave the operating position (behind the handles). Wait until the auger/impeller comes to a complete stop before unclogging the discharge chute, making any adjustments, or inspections.
18. Never put your hand in the discharge or collector openings. Always use the clean-out tool provided to unclog the discharge opening. Do not unclog discharge chute while engine is running. Shut off engine and remain behind handles until all moving parts have stopped before unclogging.
19. Use only attachments and accessories approved by the manufacturer (e.g. wheel weights, tire chains, cabs etc.).
20. If situations occur which are not covered in this manual, use care and good judgment. Contact your dealer or telephone 1- (866) 840-6483 for assistance and the name of your nearest servicing dealer.

## MAINTENANCE AND STORAGE

1. Never tamper with safety devices. Check their proper operation regularly. Refer to the maintenance and adjustment sections of this manual.
2. Before cleaning, repairing, or inspecting machine disengage all clutch levers and stop engine. Wait until the auger/impeller come to a complete stop. Disconnect the spark plug wire and ground against the engine to prevent unintended starting.
3. Check bolts and screws for proper tightness at frequent intervals to keep the machine in safe working condition. Also, visually inspect machine for any damage.
4. Do not change the engine governor setting or over-speed the engine. The governor controls the maximum safe operating speed of the engine.
5. Snow thrower shave plates and skid shoes are subject to wear and damage. For your safety protection, frequently check all components and replace with original equipment manufacturer's (OEM) parts only. "Use of parts which do not meet the original equipment specifications may lead to improper performance and compromise safety!"
6. Check clutch controls periodically to verify they engage and disengage properly and adjust, if necessary. Refer to the adjustment section in this operator's manual for instructions.
7. Maintain or replace safety and instruction labels, as necessary.
8. Observe proper disposal laws and regulations for gas, oil, etc. to protect the environment.
9. Prior to storing, run machine a few minutes to clear snow from machine and prevent freeze up of auger/impeller.
10. Never store the machine or fuel container inside where there is an open flame, spark or pilot light such as a water heater, furnace, clothes dryer etc.
11. Always refer to the operator's manual for proper instructions on off-season storage.



**WARNING: Restrict the use of this power machine to persons who read, understand and follow the warnings and instructions in this manual and on the machine.**

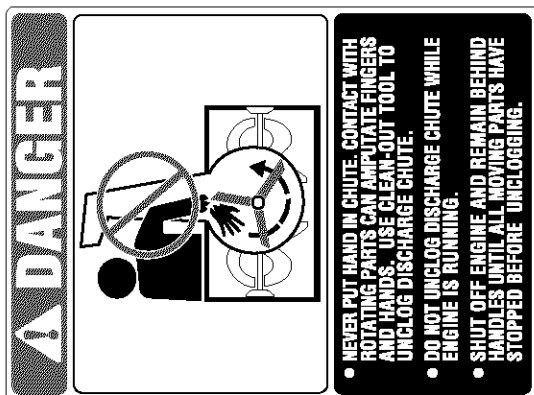

## SECTION 2: ASSEMBLING YOUR SNOW THROWER

### Unpacking

- Remove screws from the top sides and ends of the shipping crate.
- Set panel aside to avoid tire punctures or personal injury.
- Remove and discard plastic bag that covers unit.
- Remove any loose parts included with unit (i.e., Operator's Manual, etc.).
- Roll unit out of crate.

### Loose Parts

The augers are secured to the auger shaft with two shear bolts and hex lock nuts. If you hit a foreign object or ice jam, the snow thrower is designed so that the bolts may shear. Two replacement shear bolts and nuts are provided for your convenience. Store in a safe place until needed. See Figure 1.

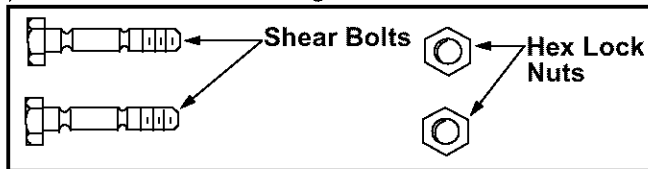

Figure 1

**IMPORTANT:** NEVER replace the auger shear bolts with standard hex bolts. Any damage to the auger gearbox or other components from using standard bolts will not be covered by your snow thrower's warranty.

### Items Required For Assembly

1. Pair of pliers
2. Engine oil
3. Fresh gasoline

### Before Assembly

- Disconnect spark plug wire and ground it against the engine to prevent unintended starting.

*NOTE: All references in this manual to the left or right side of the snow thrower is from the operating position only. Exceptions, if any, will be specified.*

### Assembling Handle

For shipping purposes, the upper handle is secured loosely to the lower handle with four wing nuts.

- Remove the **lower** plastic wing nut, cupped washer and carriage bolt from each side of the lower handle. See Figure 2.
- Raise the upper handle assembly until it locks over the lower handle.
- Look at the lower rear of the snow thrower frame to be sure all the cables are aligned with the cable roller guides. Make sure the spring (found at the

end of each cable) is attached to its actuator bracket.

- Secure the upper handle and lower handle with the two plastic wing nuts, cupped washers and carriage bolts previously removed. Attach these hardware on the lower hole in the handles. See Figure 2.
- Tighten the two wing nuts already in place on the upper holes and secure the handles firmly. Slide the shift rod connector down over the end of the lower shift rod. Tap the connector until it **locks** over the lower shift rod. See Figure 2.

*NOTE: If the connector is not properly assembled, the shift rod will pivot and you will not be able to change speeds or direction of movement.*

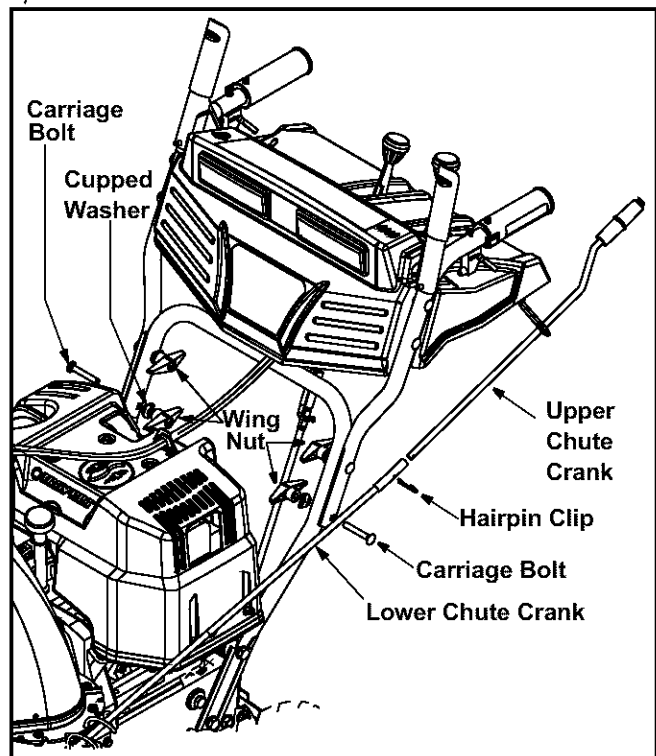

Figure 2

### Attaching Chute Crank

- Remove the hairpin clip from the upper chute crank and slide the upper chute crank through the upper chute crank bracket and into the lower chute crank. A pair of pliers may help in this job.
- Align the two holes on both chute cranks and insert the hairpin clip removed earlier, through these holes. See Figure 2.
- If not already attached, slip the cables that run from the handle panel to the discharge chute into the cable guide located on top of the engine. See Figure 3.

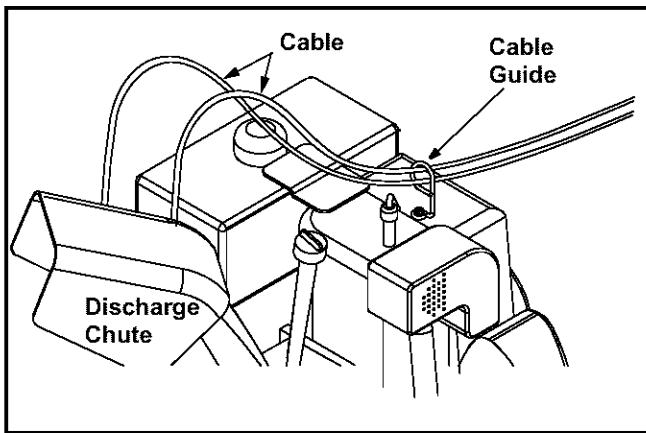

Figure 3

- Unwrap the headlight wire which is attached to the headlight, beneath the handle panel. Wind the headlight wire around the lower right handle until excess slack is removed. See Figure 4.

- Plug the wire from the headlight into the alternator lead coming from the right side of the engine underneath the fuel tank.

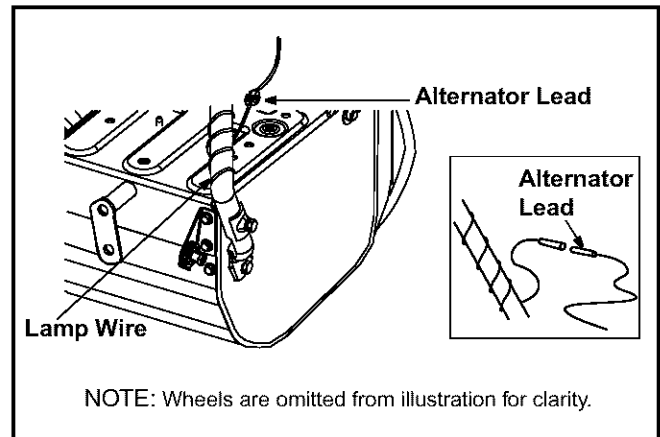

Figure 4

### Chute Clean-Out Tool

- This tool, along with the electric cord, is fastened with a cable tie to the rear of the auger housing for shipping purposes. Cut the cable tie and remove the electric cord before operating the snow thrower.

## SECTION 3: KNOW YOUR SNOW THROWER

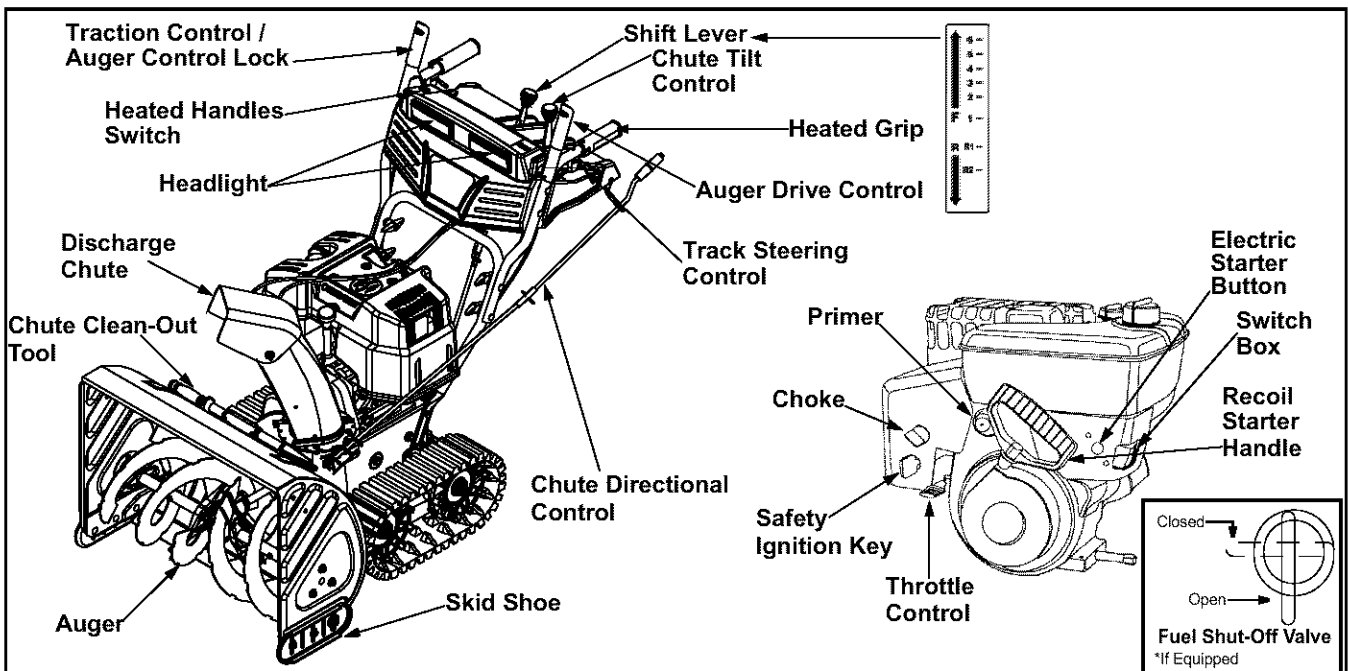

Figure 5



**WARNING:** Read, understand, and follow all instructions and warnings on the machine and in this manual before operating.

### Traction Control / Auger Control Lock

The traction control is located on the right handle. Squeeze the traction control to engage the wheel drive. Release to stop. See Figure 5.

This same lever also locks the auger control so you can turn the chute directional control without interrupting the snow throwing process. If the auger control is engaged along with the traction control, the operator can release the auger control (on the left handle) and the augers will remain engaged. Release the traction control to stop both the augers and track drive (auger control must also be released).

**IMPORTANT:** Always release tractional control before changing speeds.

## Auger Drive Control

The auger drive control is located on the left handle. Squeeze the control grip to engage the augers. Release to stop the snow throwing action. (Traction control must also be released.) See Figure 5.

## Chute Tilt Control

The distance snow is thrown can be changed by adjusting the angle of the chute assembly. Move the chute tilt control forward to decrease the distance, toward the rear to increase. See Figure 5.

## Skid Shoe

The position of the skid shoe is determined by the condition of the ground from where snow has to be removed. See Figure 5.

## Shift Lever

The shift lever is located in the center of the handle panel and is used to determine both ground speed and direction of travel. It can be moved into any of eight positions. See Figure 5.

### Forward

Your snow thrower has six forward (F) speeds. Position number one (1) is the slowest. Position number six (6) is the fastest.

### Reverse

Your snow thrower has two reverse (R) speeds. R1 is the slower, while R2 is the faster of the two.

**IMPORTANT:** Always release tractional control before changing speeds.

## Chute Directional Control

The chute directional control is located on left side of the snow thrower. See Figure 5.

To change the direction in which snow is thrown, turn chute directional control as follows:

- Crank clockwise to discharge to the left.
- Crank counterclockwise to discharge to the right.

## Chute Clean-Out Tool

The chute clean-out tool is designed to clear a clogged discharge chute. Refer to page 10 for instructions on how to properly use it.



**WARNING:** Never use your hand to clear a clogged discharge chute. Shut off engine and remain behind handles until all moving parts have stopped before unclogging.

## Heated Handles Switch

This switch is located on the right side of the snow thrower dash panel. To activate the heated handles, toggle the switch to the right to generate heat within the handle grips. Toggle the switch to the left to the OFF position after using the snow thrower. See Figure 5.

**NOTE:** *The heated handles grips are a compliment to, not a substitute for, proper cold weather outerwear for the operator's hands. It is recommended that the snow thrower operator wear gloves/mittens to avoid extremities of winter while operating this equipment.*

## Track Steering Controls

The left and right track steering controls are located on the underside of the handles and they are used to assist in steering the snow thrower. Squeeze the right track control when turning right, squeeze the left control when turning left. Operate your snow thrower in open areas until you become familiar with these controls. See Figure 5.

**NOTE:** *It is easier to maneuver a non-running snow thrower with both track steering controls held in simultaneously.*

## Throttle Control

The throttle control is located on the engine. It regulates the speed of the engine and will shut off the engine when pushed down completely. See Figure 5.

## Fuel Shut-Off Valve (Optional Equipment)

On models so equipped, the fuel shut-off valve, located under fuel tank, controls fuel-flow from the gas tank. See Figure 5.

## Safety Ignition Key

The safety ignition key must be fully inserted in the switch before the unit will start. Remove the ignition key when the snow thrower is not in use. See Figure 5.

**IMPORTANT:** Do NOT attempt to turn the key.

## Headlight

The headlight is on whenever the engine is running.

## Track Lock Lever

The track lock lever is located on the right side of the snow thrower and is used to select the position of the auger housing and the method of track operation. Move the lever to the right, then forward or backward to one of the three positions. See Figure 6.

**Transport:** Raises the front end of the snow thrower for easy transport. Using proper caution, this position may also be used on many gravel driveways to clear snow while leaving gravel undisturbed.

**Normal Snow:** Allows the tracks to be suspended independently for continuous ground contact.

**Packed Snow:** Locks the front end of the snow thrower down to the ground for hard-packed or icy snow conditions.

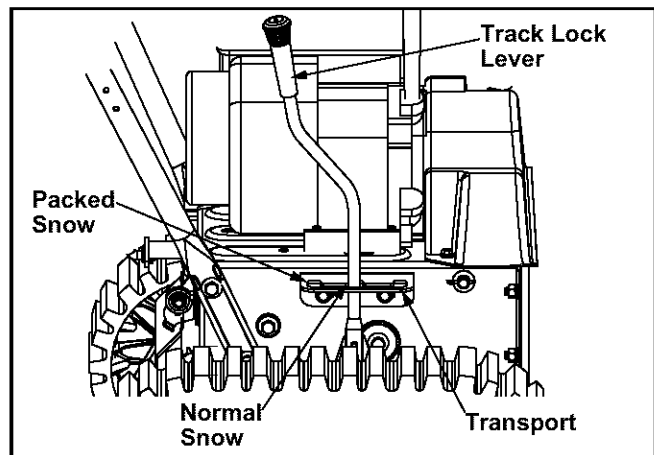

Figure 6

## SECTION 4: OPERATING YOUR SNOW THROWER

### Before Starting



**WARNING:** Read, understand, and follow all instructions and warnings on the machine and in this manual before operating.

### Gas And Oil Fill-up

Service the engine with gasoline and oil as instructed in the separate engine manual packed with your snow thrower. Read instructions carefully.



**WARNING:** Use extreme care when handling gasoline. Gasoline is extremely flammable and the vapors are explosive. Never fuel machine indoors or while the engine is hot or running. Extinguish cigarettes, cigars, pipes and other sources of ignition.

- A plastic **cup** is provided inside the fuel fill opening on the fuel tank. Remove and discard this cup before filling up the tank. Use the separate fuel tank cap to close after fill-up.

### To Start Engine

- Attach spark plug wire to spark plug. Make certain the metal loop on end of the spark plug wire (inside the boot) is fastened securely over the metal tip on the spark plug.
- Make certain the fuel shut-off valve, if so equipped, is in the OPEN (vertical) position.
- Make certain the auger and drive clutch levers are in the disengaged (released) position.
- Move throttle control up to FAST position. Insert ignition key into slot. See Figure 5. Be certain it snaps into place. **Do not turn key.**

**NOTE:** Engine will not start unless ignition key is inserted into ignition slot in carburetor cover.

### Electric Starter

- Determine that your house wiring is a three-wire grounded system. Ask a licensed electrician if you are not certain.
- If your house wiring system is not a three-wire grounded system, do not use this electric starter under any conditions.



**WARNING:** The electric starter is equipped with a grounded three-wire power cord and plug and is designed to operate on 120 volt AC household current. It must be used with a properly grounded three-prong receptacle at all times to avoid the possibility of electric shock. Follow all instructions carefully prior to operating the electric starter.

- If your home electrical system is grounded, but a three-hole receptacle is not available, one should be installed by a licensed electrician before using the electric starter.
- If you have a grounded three-prong receptacle, proceed as follows:
- Connect power cord to switch box on engine. Plug the other end of power cord into a three-prong, 120-volt, grounded, AC receptacle.
- Rotate choke knob to FULL choke position (cold engine start). If engine is warm, place choke in OFF position instead of FULL.
- Push primer button two or three times for cold engine start, making sure to cover vent hole in primer button when pushing. **DO NOT** use primer to restart a warm engine after a short shutdown.
- Push starter button to start engine.



- When engine starts, release starter button, and move choke gradually to OFF. If engine falters, move choke immediately to FULL and then gradually to OFF.
- When disconnecting the power cord, always unplug from the three-prong receptacle first and then from the snow thrower.

### Recoil Starter

- Rotate choke knob to FULL choke position (cold engine start). If engine is warm, place choke in OFF position instead of FULL.
- Push primer button three or four times for cold engine start. DO NOT use primer to restart a warm engine after a short shutdown.

**NOTE:** Always cover vent hole in primer button when pushing. Additional priming may be necessary for first start if temperature is below 15°F.

- Grasp starter handle and pull rope out slowly, until it pulls slightly harder. Let rope rewind slowly.
- Pull starter handle rapidly. Do not allow handle to snap back. Allow it to rewind slowly while keeping a firm hold on the starter handle.
- Repeat the previous steps until engine starts.
- As engine warms up and begins to operate evenly, rotate choke knob slowly to OFF position. If engine falters, return to FULL choke, then slowly move to OFF position

## To Stop Engine

- Run engine for a few minutes before stopping to help dry off any moisture on the engine.
- To help prevent possible freeze-up of starter, proceed as follows.

### Electric Starter:

- Connect power cord to switch box on engine, then to 120 volt AC receptacle. With the engine running, push starter button and spin the starter for several seconds. The unusual sound made by spinning the starter will not harm engine or starter. Disconnect the power cord from receptacle first, and then from switch box.

### Recoil Starter

- With engine running, pull starter rope with a rapid, continuous full arm stroke three or four times. Pulling the starter rope will produce a loud clattering sound, which is not harmful to the engine or starter.
- To stop engine, move throttle control to "stop" or "off" position.
- Remove ignition key. Do not turn key.
- Disconnect the spark plug wire from the spark plug to prevent accidental starting while equipment is unattended.

**NOTE:** Do not lose ignition key. Keep it in a safe place. Engine will not start without ignition key.

- Wipe all snow and moisture from the carburetor cover in the area of the control levers. Also, move control levers back and forth several times.

## To Engage Track Drive

- With the engine running near top speed, move the shift lever into one of the six FORWARD positions or two REVERSE positions. Select a speed appropriate for the snow conditions that exist.
- Squeeze the auger control grip and the augers will turn. Release it and the augers will stop.
- Squeeze traction control grip and the snow thrower will move. Release it and drive motion will stop.

**IMPORTANT:** NEVER move shift lever without releasing the traction control. Doing so will cause premature wear on the drive system's friction wheel.

## To Engage Augers

- To engage the augers and start throwing snow, squeeze the auger control grip against the left handle.
  - To disengage power to the augers, release both the auger control and the traction control, if engaged.
- The auger control can be locked so you can turn the electric chute directional control without interrupting the snow throwing process.

### Auger Control Test

**IMPORTANT:** Perform the following test before operating your snow thrower for the first time and at the start of each winter season.

Check the adjustment of the auger control as follows:

- When the auger control is released and in the disengaged "up" position, the cable should have very little slack. It should NOT be tight.
- In a well-ventilated area, start the snow thrower engine as instructed earlier in this section under the heading Starting Engine. Make sure the throttle is set in the FAST position.
- While standing in the operator's position (behind the snow thrower), engage the auger.
- Allow the auger to remain engaged for approximately ten (10) seconds before releasing the auger control. Repeat this several times.
- With the engine running in the FAST position and the auger control lever in the disengaged "up" position, walk to the front of the machine.
- Confirm that the auger has completely stopped rotating and shows NO signs of motion.

**IMPORTANT:** If the auger shows ANY signs of rotating, immediately return to the operator's position and shut off the engine. Wait for ALL moving parts to stop before re-adjusting the auger control.

- To readjust the control cable, loosen the hex jam nut on the auger control cable "Z" fitting.

- Rotate the coupling end of the cable counterclockwise to provide more slack.
- Retighten the hex jam nut. See Figure 7.
- Repeat Auger Control Test to verify proper adjustment has been achieved.

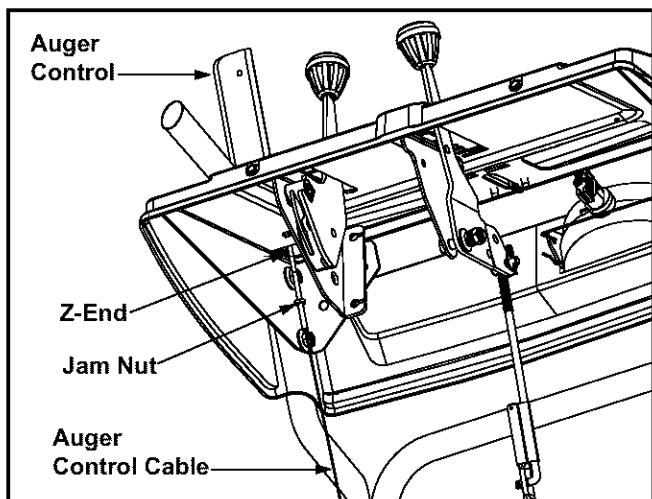

Figure 7

## Chute Clean-Out Tool

The chute clean-out tool is conveniently fastened to the rear of the auger housing with a mounting clip. Should snow and ice lodge itself in the discharge chute during operation, proceed as follows to safely clean the chute and chute opening:

- Release both the Auger Control Lever and the Traction/Auger Control Lock Lever.
- Stop the engine by removing the ignition key.
- Remove the clean-out tool from the clip which secures it to the rear of the auger housing.
- Use the shovel-shaped end of the clean-out tool to dislodge and scoop any snow and ice which has formed in and near the discharge chute.



**WARNING:** Never use your hands to clean snow and ice from the discharge chute or auger housing

- Refasten the clean-out tool to the mounting clip on the rear of the auger housing, reinsert the ignition key and start the snow thrower's engine.
- While standing in the operator's position (behind the snow thrower), engage the auger clutch lever for a few seconds to clear any remaining snow and ice from the discharge chute.

## Drift Cutters (If Equipped)

Drift cutters should be used when operating the snow thrower in heavy drift conditions.

On models so equipped, drift cutters are assembled to the auger housing inverted. Remove the carriage bolts by unthreading the hex nuts which secure them, and reinstall the drift cutters in their proper position before operating the snow thrower. See Figure 8.

If your unit is not equipped with drift cutters, contact Customer Support as instructed on page 2 for information regarding price and availability.

Snow Thrower Model	Drift Cutter Kit
All models	OEM-390-679

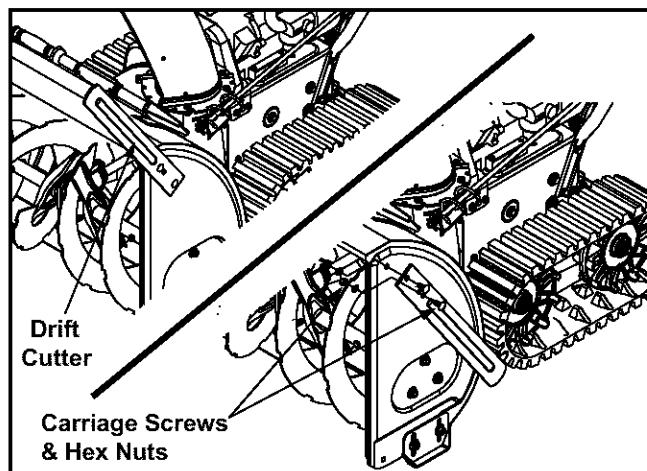

Figure 8

## Operating Tips

**NOTE:** Allow the engine to warm up for a few minutes. The engine will not develop full power until it reaches operating temperature.



**WARNING:** The temperature of the muffler and the surrounding areas may exceed 150° F. Avoid these areas.

- For the most efficient snow removal, remove snow immediately after it falls.
- Discharge the snow downwind whenever possible.
- Slightly overlap each previous path.
- Set the skid shoes 1/4" below the shave plate for normal usage. The skid shoes may be adjusted upward (to lower the shave plate) for hard-packed snow. Adjust downward (to raise the shave plate) when using on gravel or crushed rock.
- Be certain to follow the precautions found in the To Stop Engine section to prevent possible freeze-up.
- Clean the snow thrower thoroughly after each use.

## SECTION 5: MAKING ADJUSTMENTS



**WARNING:** NEVER attempt to make any adjustments while the engine is running, except where specified in the operator's manual.

### Chute Assembly

The distance snow is thrown can be adjusted by changing the angle of the chute assembly. Move the chute tilt control forward to decrease the distance, toward the rear to increase.

### Auger Control

Refer to Auger Control Test in the Operating Section to adjust the auger control.

### Traction Control and Shift Lever

To check the adjustment of the traction control and shift lever, proceed as follows:

- To check the adjustment of the traction control clutch and shift lever, proceed as follows:
- With the engine off, move the shift lever all the way forward to the highest speed. With the traction control lever released, push the snow thrower forward. The unit should roll forward. Then engage the traction control grip. The wheels should stop turning.
- Now release the traction control grip and push the unit again.
- Move the shift lever back to the fast reverse position then all the way forward again. There should be no resistance in the shift lever, and the wheels should keep turning.
- If you have resistance when moving the shift lever or the wheels stop when they should not, loosen the jam nut on the traction control cable and unthread the cable one turn.
- If the wheels do not stop when you engage the traction control clutch grip, loosen the jam nut on the traction control cable and thread the cable in one turn.
- Recheck the adjustment and repeat as necessary. Tighten the jam nut to secure the cable when correct adjustment is reached.



**WARNING:** Drain the gasoline out of the snow thrower's tank, or place a piece of plastic film under the gas cap to avoid spillage BEFORE making the adjustment.

To test further for correct adjustment, if necessary, proceed as follows:

- Tip the snow thrower forward, allowing it to rest on the auger housing. See Figure 9.

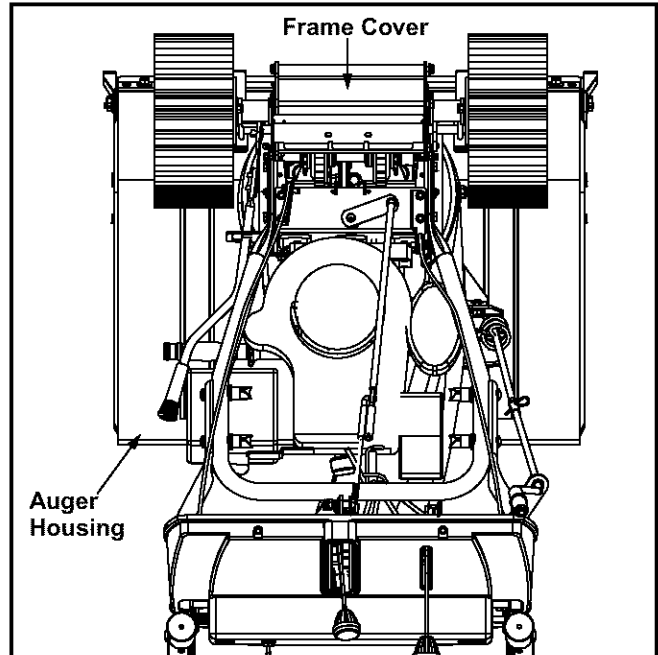

Figure 9

- Remove the frame cover underneath the snow thrower by removing the six self-tapping screws.
- With the traction control released, there must be clearance between the friction wheel and the drive plate in all positions of the shift lever.
- With the traction control engaged, the friction wheel must contact the drive plate. See Figure 10.

If adjustment is necessary:

- Loosen the jam nut on the traction drive cable. Adjust the cable as necessary.
- Retighten the jam nut to secure the cable when correct adjustment is reached.
- Reassemble the frame cover.

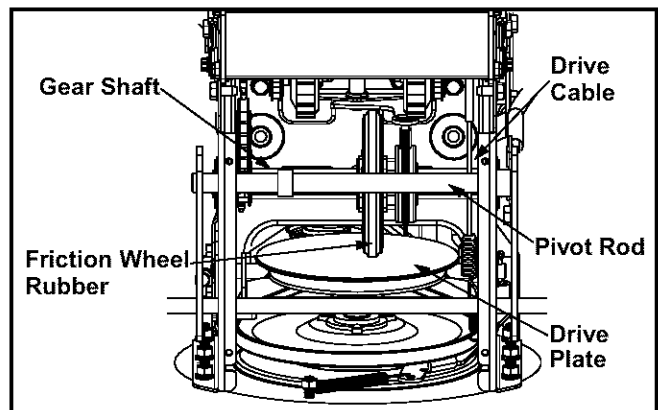

Figure 10

**NOTE:** If you placed plastic film under the gas cap, be certain to remove it before operating the snow thrower.

## Shift Rod Adjustment

To adjust the shift rod, proceed as follows:

- Remove the hairpin clip and slide the shift rod connector up, to separate the upper shift rod from the lower shift rod. See Figure 11.
- Place the shift lever into the sixth (6) position.
- Rotate the shift arm clockwise (from the operator's position) as far as it will go.
- Thread the upper shift rod downward until the elbow on its lower end aligns with the hole found in the lower shift rod.

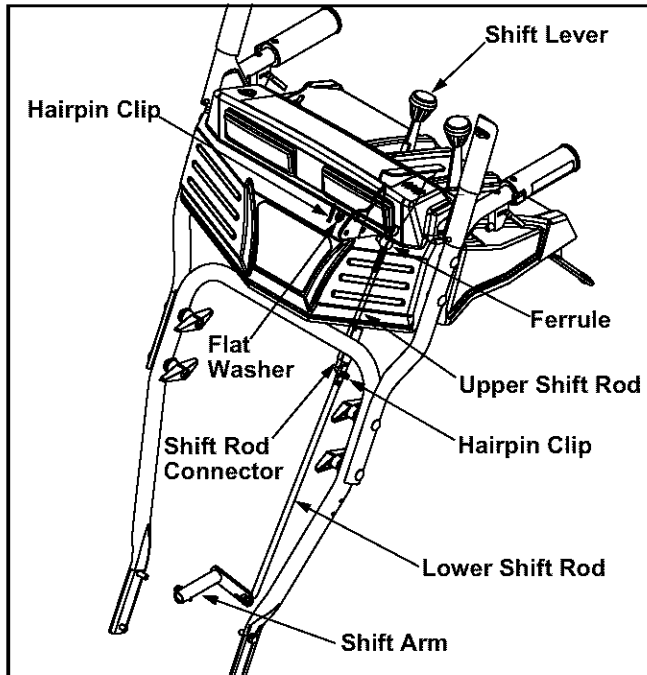

Figure 11

- Reconnect the upper shift rod to the lower shift rod by reinserting the hairpin clip removed earlier and sliding the shift rod connector back down into place.

**IMPORTANT:** Make certain to check for correct adjustment of the shift rod as instructed under Final Adjustments in the Assembly Section, before operating the snow thrower.

## Skid Shoes

The space between the shave plate and the ground can be adjusted. See Figure 12.

- For close snow removal on a smooth surface, raise skid shoes higher on the auger housing.
- Use a middle or lower position when the area to be cleared is uneven.

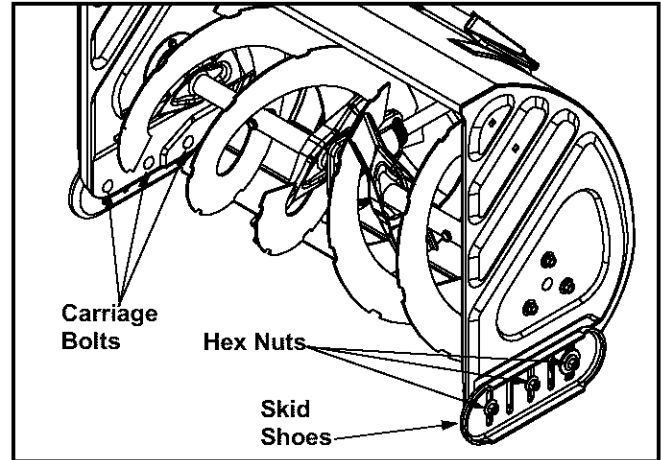

Figure 12



**WARNING:** Do not operate this snow thrower on gravel as loose gravel can be easily picked up and thrown by the auger causing injury to the operator and/or damage to the snow thrower.

- Adjust skid shoes by loosening the three hex nuts and carriage bolts. Move skid shoes to desired position.
- Make certain the entire bottom surface of skid shoe is against the ground to avoid uneven wear on the skid shoes. Retighten nuts and bolts securely.
- Repeat on the other side of the snow thrower.

## Carburetor

- Minor carburetor adjustment may be required to compensate for differences in fuel, temperature, altitude and load.
- Refer to the separate engine manual, packed with your unit, for carburetor adjustment information.

## SECTION 6: MAINTAINING YOUR SNOW THROWER



**WARNING:** Before lubricating, repairing, or inspecting, disengage all clutch levers and stop engine. Wait until all moving parts have come to a complete stop. Disconnect spark plug wire and ground it against the engine to prevent unintended starting.

## Lubrication

### Engine

Refer to the separate engine manual packed with your unit for all engine lubrication instructions.



**WARNING:** If any adjustments need to be made to the engine while the engine is running (e.g. carburetor), keep clear of all moving parts. Be careful of muffler, engine and other surrounding heated surfaces.

### Gear Shaft

Lubricate the gear shaft with 6-n-1 grease at least once a season or after every 25 hours of operation (available at automotive stores, or order part number 737-0170). Refer to Figure 10.

**IMPORTANT:** Keep all grease and oil off of the rubber friction wheel and aluminum drive plate.

### Chute Directional Control

- The worm gear on the chute directional control should be greased with multipurpose automotive grease.

### Gear Case

The gear case is lubricated with grease at the factory and it does not require checking. If disassembled for any reason, lubricate with 2 ounces of Shell Alvania grease EPR00, part number 737-0168. Before reassembling, remove old sealant and apply new sealant. See Figure 14.

To check the level of grease in the gear case, remove the vent plug. If necessary, add grease using a grease gun and the grease fitting on the side of the gear case.

**IMPORTANT:** Do not overfill the gear case, since damage to the seals could result. Be sure the vent plug is free of grease in order to relieve pressure.

### Traction Control / Auger Control Lock

The cams on the ends of the control rods which interlock the traction drive and auger drive controls must be lubricated at least once a season or every 25 hours of operation. The cams can be accessed beneath the handle panel. Use a multi-purpose automotive grease. See Figure 13.

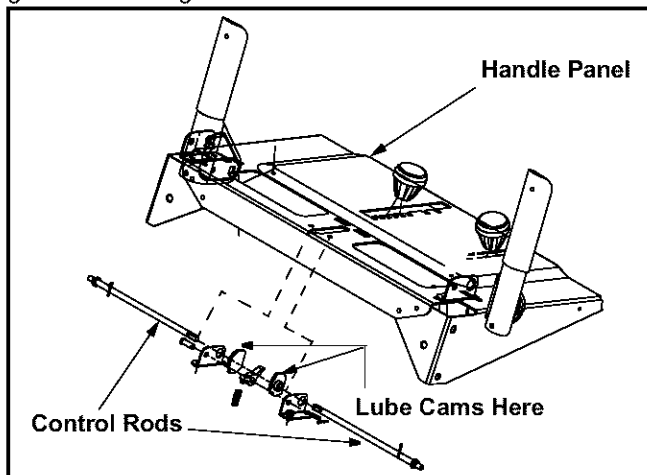

Figure 13

### Auger Shaft

- At least once a season, remove the shear bolts from the auger shaft and spray lubricant inside the shaft. See Figure 14.

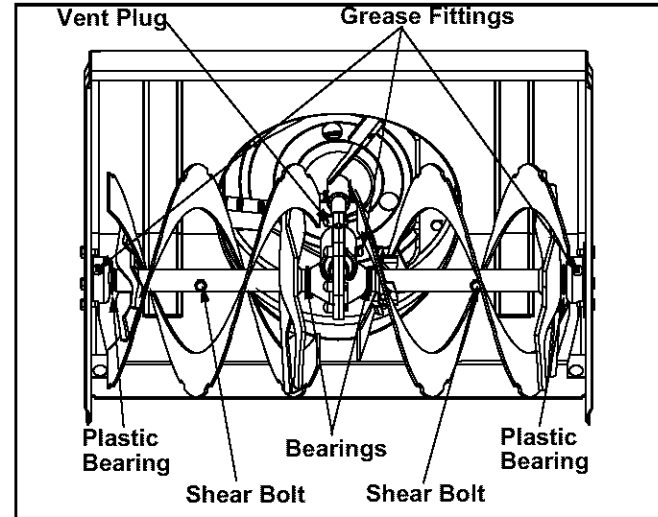

Figure 14

- Grease fittings can be found at either end of the auger shaft. Lubricate with a grease gun once a season. See Figure 14.

### Auger Bearings

Every season lubricate the auger bearings and the bearings on the side of the frame with light oil. See Figure 14.

### Drive and Shifting Mechanism

Lubricate at least once a season or after every 25 hours of operation. Remove the rear cover, lubricate any chains, sprockets, gears, bearings, shafts, and shifting mechanism at least once a season. Use engine oil or a spray lubricant. **Avoid getting oil on the friction wheel rubber and aluminum drive plate.** Refer to Figure 10.

There is a grease fitting on the top of the axle shaft which drives the rear track drive wheels on both sides of the unit. Grease these fittings every 25 hours or once a season.

## SECTION 7: SERVICING YOUR SNOW THROWER



**WARNING:** Before servicing, repairing, or inspecting, disengage all clutch levers and stop engine. Wait until all moving parts have come to a complete stop. Disconnect spark plug wire and ground it against the engine to prevent unintended starting.

### Augers

- The augers are secured to the spiral shaft with two shear bolts and hex lock nuts. If you hit a hard foreign object or ice jam, the snow thrower is designed so that the bolts may shear. Refer to Figure 14.
- If the augers will not turn, check to see if the bolts have sheared. Replacement shear bolts and hex lock nuts have been provided with the snow thrower. When replacing bolts, spray an oil lubricant into shaft before inserting new bolts.

**IMPORTANT:** NEVER replace the auger shear bolts with standard hex bolts. Any damage to the auger gearbox or other components as a result of doing so will NOT be covered by your snow thrower's warranty.

### Shave Plate and Skid Shoes

- The shave plate and skid shoes on the bottom of the snow thrower are subject to wear. They should be checked periodically and replaced when necessary.
- Remove the six carriage bolts, belleville washers and hex nuts which attach two skid shoes to the snow thrower on two sides. See Figure 12.
- Reassemble new skid shoes with the hardware removed earlier (cupped side of belleville washer against the skid shoes). Make certain the skid shoes are adjusted to be level.
- To remove the shave plate, remove the carriage bolts, belleville washers and hex nuts which attach the shave plate to the snow thrower housing. See Figure 15.
- Reassemble the new shave plate, with heads of carriage bolts to the inside of the housing. Tighten securely.

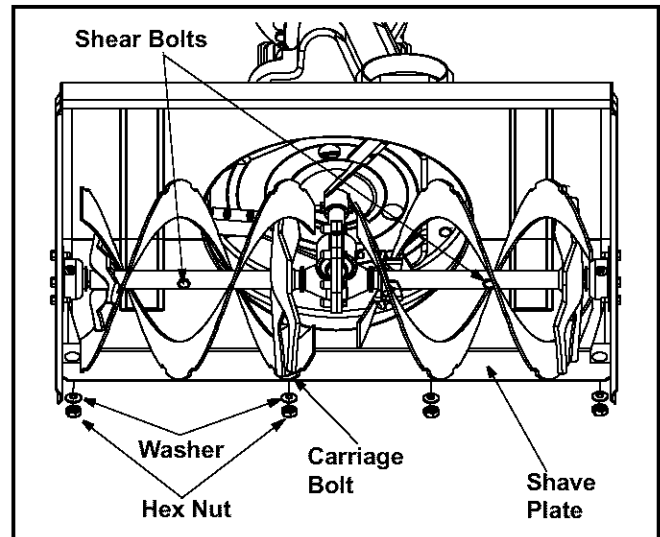

Figure 15

## Belt Removal And Replacement

### Auger Belts

**NOTE:** It is necessary to remove both belts in order to change either one. If changing just one belt, be certain to check the condition of the other belt.

- Disconnect the chute crank assembly at the discharge chute end by removing the hairpin clip and the flat washer. See Figure 16A.
- Remove the engine shroud by removing the lock nuts and bolts securing it. See Figure 16B.
- Remove the plastic belt cover at the front of the engine by removing the two self-tapping screws. See Figure 16B.
- Drain the gasoline from the snow thrower, or place a piece of plastic film under the gas cap.
- Tip the snow thrower up and forward so that it rests on its auger housing. Refer to Figure 9.

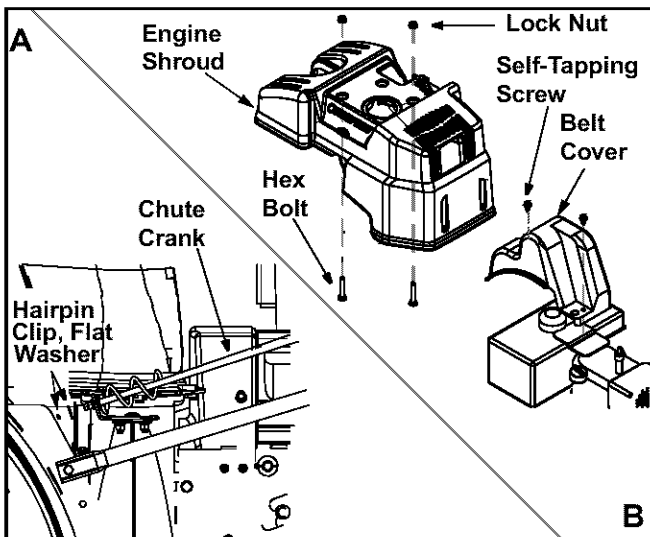

Figure 16

- Remove the six self-tapping screws from the frame cover underneath the snow thrower.
- Roll the front and rear auger belts off the engine pulley. See Figure 17.
- Unhook the idler spring from the hex bolt on the auger housing. See Figure 18.
- Back out the stop bolt until the support bracket rests on the auger pulley. See Figure 19.

**NOTE:** Loosening the six nuts that connect the frame to the auger housing may aid in belt removal.

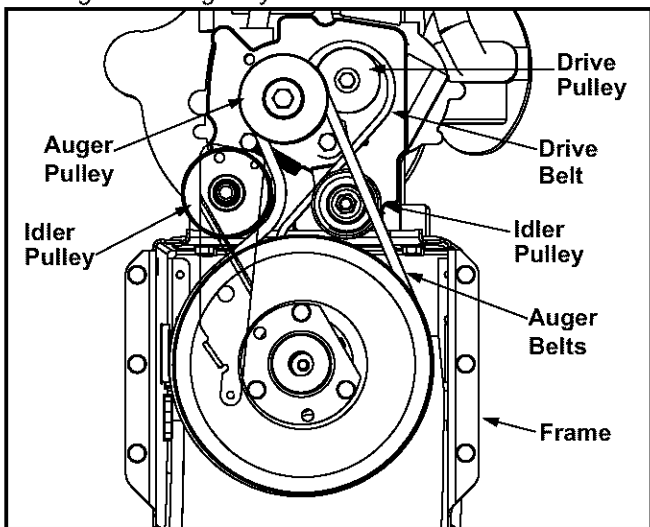

Figure 17

- Lift the auger belt from the auger pulley, and slip belt between the support bracket and the auger pulley. Repeat this step for the front auger belt. See Figure 18.
- Replace both auger drive belts by following instructions in reverse order.

**NOTE:** If you placed plastic film under the gas cap, be certain to remove it before operating the snow thrower.

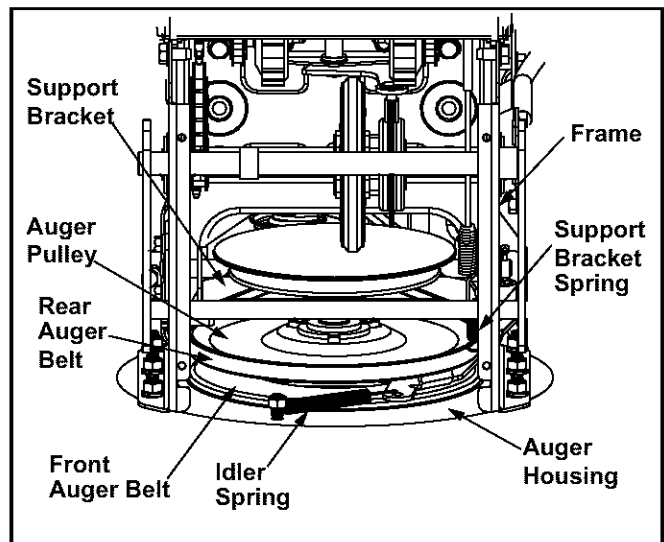

Figure 18

### Drive Belt

- Follow the first six steps of the instructions for servicing the auger belts.
- Pull the idler pulley up and lift the belt off the engine pulley and friction wheel disc. See Figure 17.
- Back out the stop bolt until the support bracket rests on the auger pulley. See Figure 19.
- Slip the belt between the friction wheel and drive disc. Remove and replace the belt. Reassemble following the instructions in reverse order.

**NOTE:** The support bracket must rest on the stop bolt after the new belt has been assembled. See Figure 19.

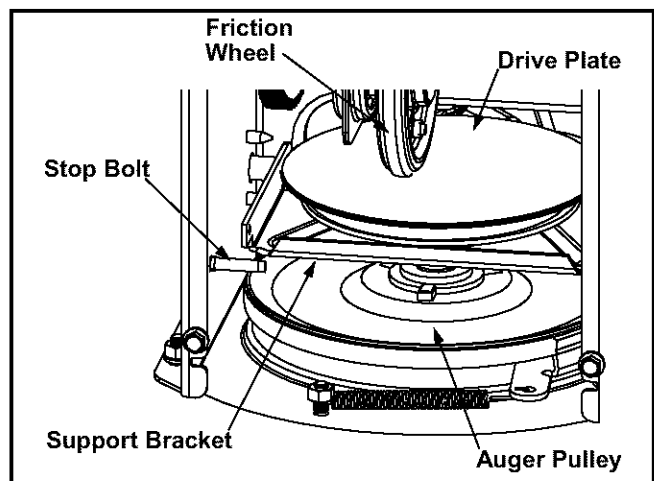

Figure 19

### Replacing Friction Wheel Rubber

The rubber on the friction wheel is subject to wear and should be checked after 25 hours of operation, and periodically thereafter. Replace the friction wheel rubber if any signs of wear or cracking are found.

- Drain the gasoline from the snow thrower.

- Tip the snow thrower up and forward, so that it rests on the housing. Refer to Figure 9.
- Remove six self-tapping screws from the frame cover underneath the snow thrower.
- Remove the click pins which secure the wheels, and remove the wheels from the axle.
- Using a 7/8" wrench to hold the shaft, loosen, but do not completely remove, the hex bolt and bell washer on the left end of gear shaft. See Figure 20.
- Lightly tap the hex nut to dislodge the ball bearing from the right side of frame before removing the hex nut and bell washer from left end of shaft.

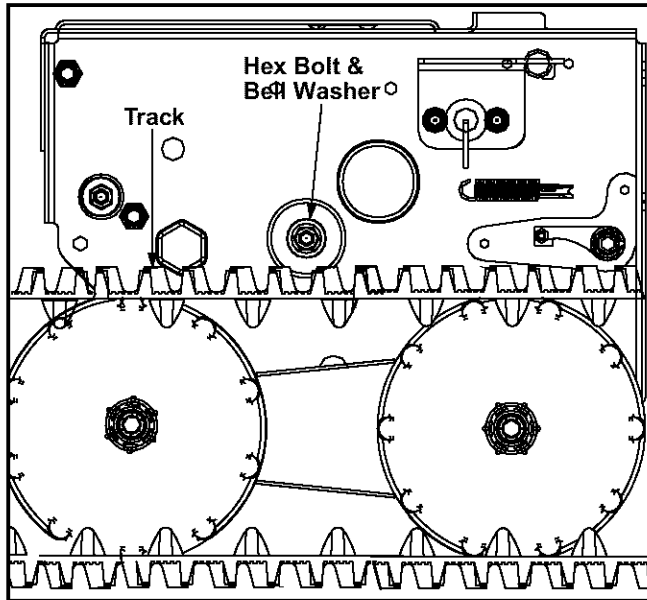

Figure 20

- Move the gear shaft to the right and slide the friction wheel assembly from the shaft. See Figure 21A.
- Remove the four screws from the friction wheel assembly. See Figure 21B.
- Remove the friction wheel rubber from between the friction wheel plates.
- Reassemble new friction wheel rubber to the friction wheel plates and hub, tightening the four screws in rotation and with equal force.
- Position the friction wheel assembly up onto the pin of the shift rod assembly, and slide the shaft through the assembly. Reassemble in reverse order.

## Engine

Refer to the separate engine manual packed with your unit for all engine maintenance procedures.

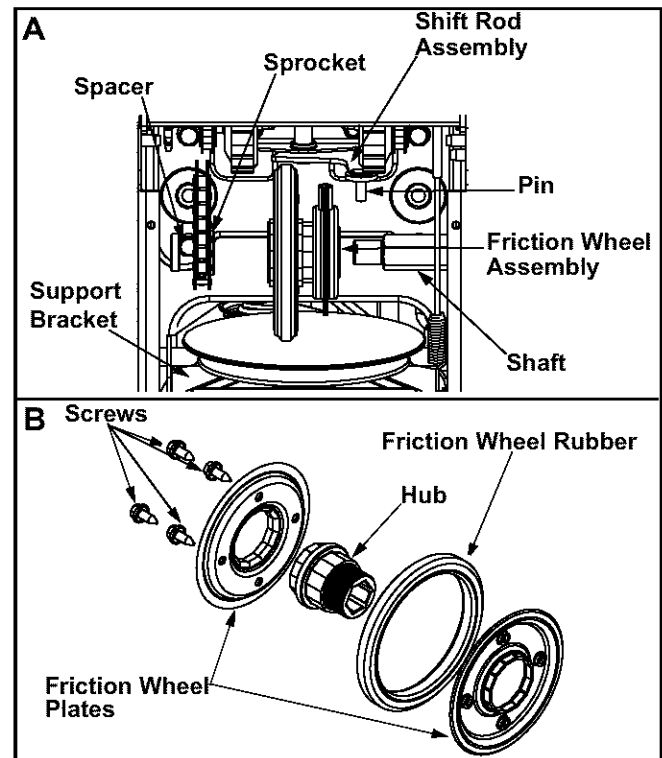

Figure 21

## Off-Season Storage



**WARNING:** Never store the machine or fuel container indoors where there is an open flame, spark, or pilot light such as on water heater, furnace, clothes dryer, or other gas appliance.



**WARNING:** Drain fuel into an approved container outdoors, away from an open flame. Allow engine to cool. Extinguish cigarettes, cigars, pipes, and other sources of ignition prior to draining fuel. Fuel left in engine for extended periods deteriorates and will cause starting problems.

If unit is to be stored over 30 days, prepare for storage as follows:

- Remove gasoline from carburetor and fuel tank to prevent gum deposits from forming on these parts and causing possible malfunction of engine.
- Run engine until fuel tank is empty and engine stops due to lack of fuel.
- Drain carburetor by pressing upward on bowl drain, located below the carburetor cover.

**NOTE:** Fuel stabilizer is an acceptable alternative in minimizing the formation of fuel gum deposits during storage. Do not drain carburetor if using fuel stabilizer.



- Wipe equipment with an oiled rag to prevent rust.
- Remove spark plug and pour one ounce of engine oil through spark plug hole into cylinder. Cover spark plug hole with rag. Crank engine several times to distribute oil. Replace spark plug.
- Follow the lubrication recommendations found in the Maintenance Section.
- Always store the snow thrower in a clean, dry area.

**NOTE:** When storing any type of power equipment in an unventilated or metal storage shed, care should be taken to rust proof the equipment. Using a light oil or silicone, coat the equipment, especially any chains, springs, bearings, and cables.

## SECTION 8: TROUBLESHOOTING

Problem	Cause	Remedy
Engine fails to start	<ol style="list-style-type: none"> <li>1. Fuel tank empty, or stale fuel.</li> <li>2. Blocked fuel line.</li> <li>3. Choke not in the ON position</li> <li>4. Faulty spark plug.</li> <li>5. Safety key not in ignition switch on engine.</li> <li>6. Spark plug wire disconnected.</li> <li>7. Primer button not being used properly.</li> <li>8. Fuel shut-off valve closed. (If Equipped)</li> </ol>	<ol style="list-style-type: none"> <li>1. Fill tank with clean, fresh gasoline. Fuel becomes stale after thirty days.</li> <li>2. Clean the fuel line.</li> <li>3. Move switch to the ON position</li> <li>4. Clean, adjust gap or replace.</li> <li>5. Insert the key fully into the switch.</li> <li>6. Connect spark plug wire.</li> <li>7. Refer to the engine manual.</li> <li>8. Open fuel shut-off valve. (If Equipped)</li> </ol>
Engine runs erratic	<ol style="list-style-type: none"> <li>1. Unit running on CHOKE.</li> <li>2. Blocked fuel line or stale fuel.</li> <li>3. Water or dirt in the fuel system.</li> </ol>	<ol style="list-style-type: none"> <li>1. Move the choke lever to OFF position.</li> <li>2. Clean the fuel line; fill the tank with clean, fresh gasoline.</li> <li>3. Drain the fuel tank and carburetor. Refill with fresh fuel.</li> </ol>
Loss of power	<ol style="list-style-type: none"> <li>1. Spark plug wire loose.</li> <li>2. Gas cap vent hole plugged.</li> </ol>	<ol style="list-style-type: none"> <li>1. Connect and tighten spark plug wire.</li> <li>2. Remove ice and snow from gas cap. Be certain vent hole is clear.</li> </ol>
Excessive vibration	<ol style="list-style-type: none"> <li>1. Loose parts or damaged auger.</li> </ol>	<ol style="list-style-type: none"> <li>1. Stop the engine immediately and disconnect the spark plug wire. Tighten all bolts and nuts. If vibration continues, have the unit serviced by an authorized service dealer.</li> </ol>
Unit fails to propel itself	<ol style="list-style-type: none"> <li>1. Traction control cable in need of adjustment.</li> <li>2. Drive belt loose or damaged.</li> </ol>	<ol style="list-style-type: none"> <li>1. Adjust traction control cable. Refer to Making Adjustment Section.</li> <li>2. Replace drive belt. Refer to the Service Section.</li> </ol>
Unit fails to discharge snow	<ol style="list-style-type: none"> <li>1. Discharge chute clogged.</li> <li>2. Shear bolt sheared.</li> <li>3. Foreign object lodged in auger.</li> <li>4. Auger control cable in need of adjustment.</li> <li>5. Auger belt loose or damaged.</li> <li>6. Shear bolt(s) sheared.</li> </ol>	<ol style="list-style-type: none"> <li>1. Stop engine and disconnect spark plug wire. Clean discharge chute and inside of auger housing.</li> <li>2. Replace shear bolt.</li> <li>3. Stop engine immediately and disconnect spark plug wire. Remove object from auger.</li> <li>4. Adjust auger control cable. Refer to the Making Adjustments Section.</li> <li>5. Refer to Service Section.</li> <li>6. Replace shear bolt(s).</li> </ol>
Electric chute fails to turn	<ol style="list-style-type: none"> <li>1. Loose electrical connections.</li> <li>2. Blown Fuse.</li> </ol>	<ol style="list-style-type: none"> <li>1. Make sure all connections are tight and fully installed.</li> <li>2. Replace fuse. Located under handle panel near switch connector.</li> </ol>
Electric chute turns in opposite direction of the switch	<ol style="list-style-type: none"> <li>1. The switch connector is installed backwards</li> </ol>	<ol style="list-style-type: none"> <li>1. Unplug the switch connector under the handle panel. Turn connector 180° and reconnect.</li> </ol>

# SECTION 9: PARTS LIST FOR MODEL 31AH7T74063

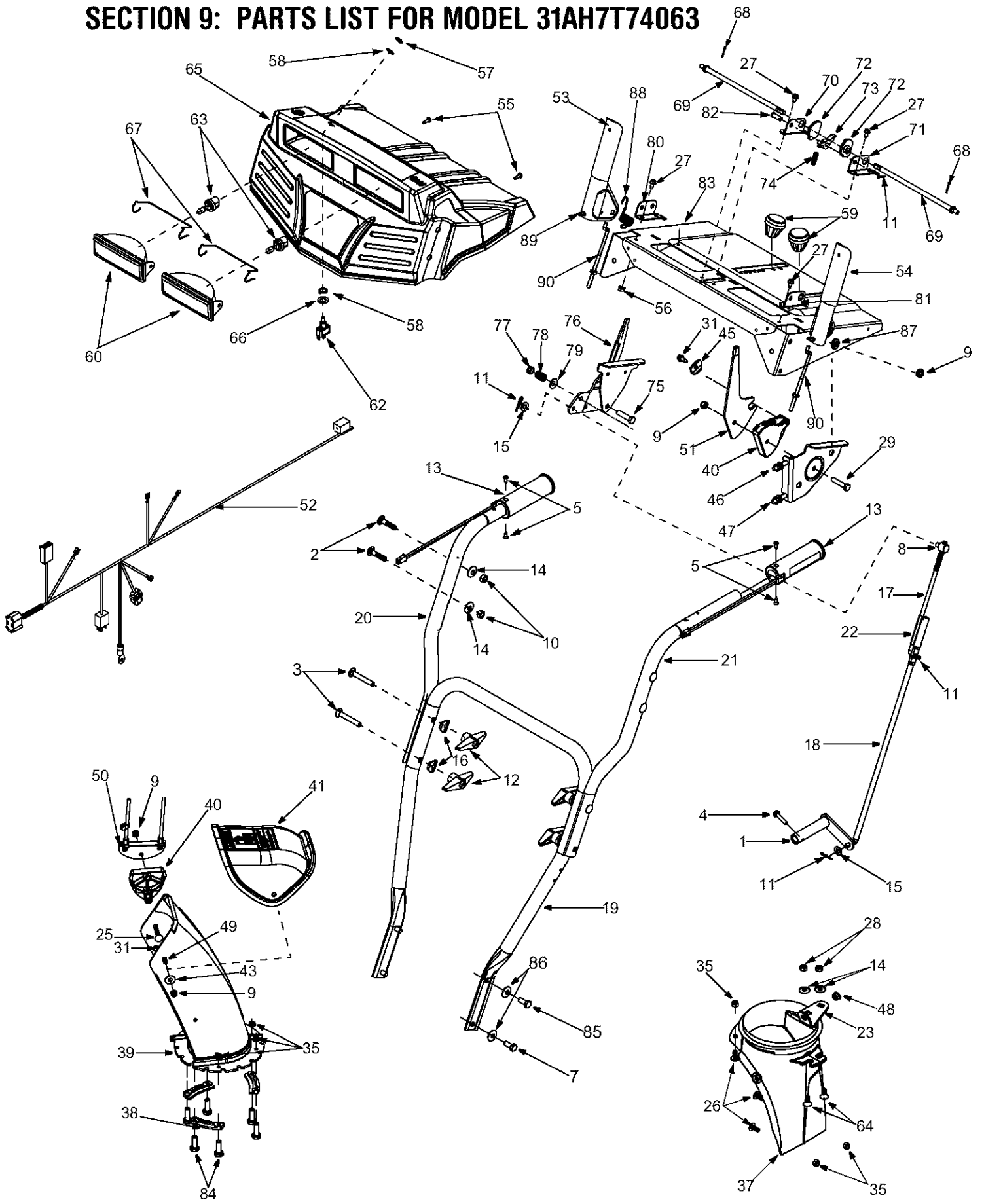

# Model 31AH7T74063

Ref. No.	Part No.	Part Description	Ref. No.	Part No.	Part Description
1.	684-0008A	Shift Arm Assembly	50.	784-5594	Cable Bracket
2.	710-0458	Carriage Bolt 5/16-18 x 1.75"	51.	784-5604	Handle: Chute Tilt
3.	710-0449	Carriage Bolt 5/16-18 x 2.25"	52.	629-04007	Upper Harness Assembly
4.	710-0788	TT Screw 1/4-20 x 1"	53.	684-0036A	Engagement Handle Assy. RH
5.	710-0837	C-Sunk Screw #10-16x 0.625"	54.	684-0037B	Engagement Handle Assy. LH
7.	710-1880	Hex Screw 5/16-18 x.75"	55.	710-1003	Special Hex Screw
8.	711-0677	Ferrule	56.	712-0271	Hex Sems Nut: 1/4-20
9.	712-0429	Hex Lock Nut 5/16-18	57.	712-0693	Hex Nut
10.	712-3068	Hex Nut 5/16-18	58.	716-0398	Lock Ring: Toggle Switch
11.	714-0104	Cotter Pin	59.	720-0232	Shift Knob
12.	720-0284	Handle Knob	60.	725-1672	Lamp Housing
13.	725-1757	Heated Grip	62.	725-1756	Toggle Switch: Single Switch
14.	736-0242	Belleville Washer	63.	725-1658	Halogen Lamp: 27W, 12V
15.	736-0275	Flat Washer	64.	710-0451	Carriage Bolt 5/16-18 x.750
16.	736-0451	Saddle Washer	65.	731-04068	Handle Panel
17.	747-0620A	Shift Rod: Upper	66.	736-0226	Flat Washer
18.	747-0621	Shift Rod: Lower	67.	747-1136	Headlight Retainer
19.	749-0951	Lower Handle	68.	714-0507	Cotter Pin: 3/32 x.75
20.	749-0952A	Upper Handle: L Style RH	69.	747-0877	Cam Rod
21.	749-0953A	Upper Handle: L Style LH	70.	784-5680	RH Handle Support Bracket
22.	750-0963	Connector: Shift Rod	71.	784-5679	LH Handle Support Bracket
23.	784-5647	Chute Crank Bracket	72.	748-0362	Cam Handle Lock
25.	710-0262	Carriage Bolt: 5/16-18 x 1.5"	73.	748-0363	Handle Lock Pawl
26.	710-0703	Carriage Screw: 1/4-20	74.	732-0145	Compression Spring:.36 x 1.0
27.	710-0599	TT Screw: 1/4-20 x 0.5"	75.	710-0459A	Hex Cap Screw: 3/8-24 x 1.5
28.	712-3010	Hex Nut 5/16-18	76.	784-5619A	Shift Handle
29.	710-0805	Hex Screw: 5/16-18 x 1.5"	77.	712-0116	Jam Nut, 3/8-24
31.	710-0895	Hex Screw AB:1/4-14 x 0.625"	78.	732-0193	Comp. Spring:.39 x.6 x.88
35.	712-3027	Hex Flange Lock Nut	79.	736-0105	Bell Washer
37.	731-1379C	Chute Adapter	80.	784-5682	RH Handle Support Bracket
38.	731-0851A	Chute Flange Keeper	81.	784-5681	LH Handle Support Bracket
39.	731-1300B	Lower Chute	82.	711-0653	Clevis Pin
40.	731-1313C	Cable Guide: Chute Tilt	83.	684-0102	Handle Panel
41.	731-04427	Upper Chute	84.	710-3015	Screw 1/4-20 x.75
43.	736-0159	5/16 Washer	85.	710-0643	Screw 5/16-18 x 1.00
45.	736-0506	Special Washer	86.	736-0119	Lock Washer 5/16
46.	746-0896	Control Cable	87.	736-0509	Special Washer
47.	746-0901	Control Cable	88.	732-0746	Torsion Spring
48.	741-0475	Plastic Bushing	89.	735-0199A	Rubber Bumper
49.	710-04071	Carriage Bolt 5/16-18 x 1.00	90.	746-0778	Z-Fitting

# Model 31AH7T74063

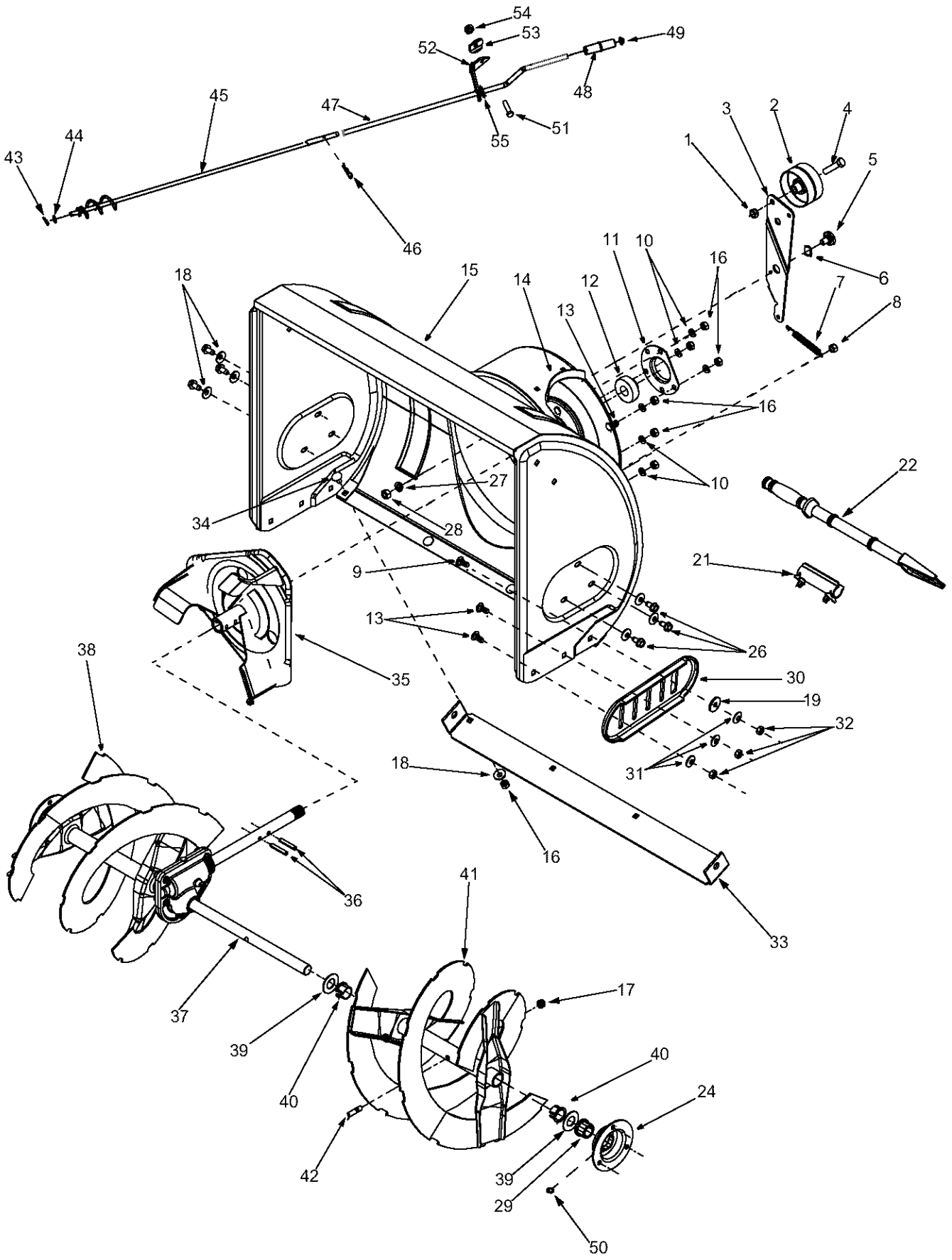

# Model 31AH7T74063

Ref. No.	Part No.	Part Description	Ref. No.	Part No.	Part Description
1.	712-0116	Lock Jam Nut 3/8-24	30.	784-5038B	Skid Shoe
2.	756-0178	Flat Idler	31.	736-0242	Bell Washer
3.	784-5632B	Auger Idler Arm	32.	712-3010	Hex Nut 5/16-18
4.	710-0459A	Hex Cap Screw 3/8-24 x 1.50	33.	784-5582A	Shave Plate
5.	738-0281	Shoulder Screw	34.	710-0451	Carriage Bolt 5/16-18 x 1.00
6.	736-0167	Flat Washer.656 ID x 1.25 OD	35.	684-0065	Impeller Assembly
7.	732-0611	Extension Spring	36.	715-0114	Pin
8.	712-3068	Hex Nut 5/16-18	37.	618-0416A	Gear Assembly Complete, 28"
9.	710-0276	Carriage Bolt, 5/16-18 x 1.00	38.	605-5196A	Spiral Assembly: RH 28"
10.	736-0119	Lock Washer 5/16	39.	736-0188	Flat Washer
11.	05931A	Housing	40.	741-0493A	Flange Bushing
12.	741-0309	Ball Bearing	41.	605-5197A	Spiral Assembly: LH 28"
13.	710-0451	Carriage Bolt, 5/16-18 x.75	42.	710-0890A	Shear Bolt 5/16-18 x 1.5
14.	705-5226	Chute Reinforcement	43.	714-0104	Hairpin Clip
15.	684-04003	Auger Housing Assy. 28"	44.	736-0185	Flat Washer
16.	712-3010	Hex Nut 5/16-18	45.	684-0053B	Chute Crank Assembly
17.	712-0429	Lock Nut 5/16-18	46.	714-0145	Hairpin Clip
18.	736-0242	Belleville Washer	47.	747-0737	Upper Chute Crank
19.	736-0320	Flat Wshr.,.38ID x 1.38 OD	48.	720-0201A	Chute Crank Knob
21.	731-2635	Clean-Out Tool Mount	49.	726-0100	Push Cap
22.	731-2643	Clean-Out Tool	50.	737-3000	Lube Fitting
24.	784-0399	Bearing Housing	51.	710-3015	Screw 1/4-20 x.75
26.	710-0726	Hex Screw 5/16-12	52.	705-5266	Chute Crank Bracket
27.	736-0169	Lock Washer 3/8	53.	736-0270	Bell Washer.265 x.75 x.062
28.	712-0798	Hex Nut 3/8-16	54.	712-0287	Hex Nut 1/4-20
29.	741-0245	Hex Flange Bearing	55.	741-0475	Plastic Bushing.380ID

# Model 31AH7T74063

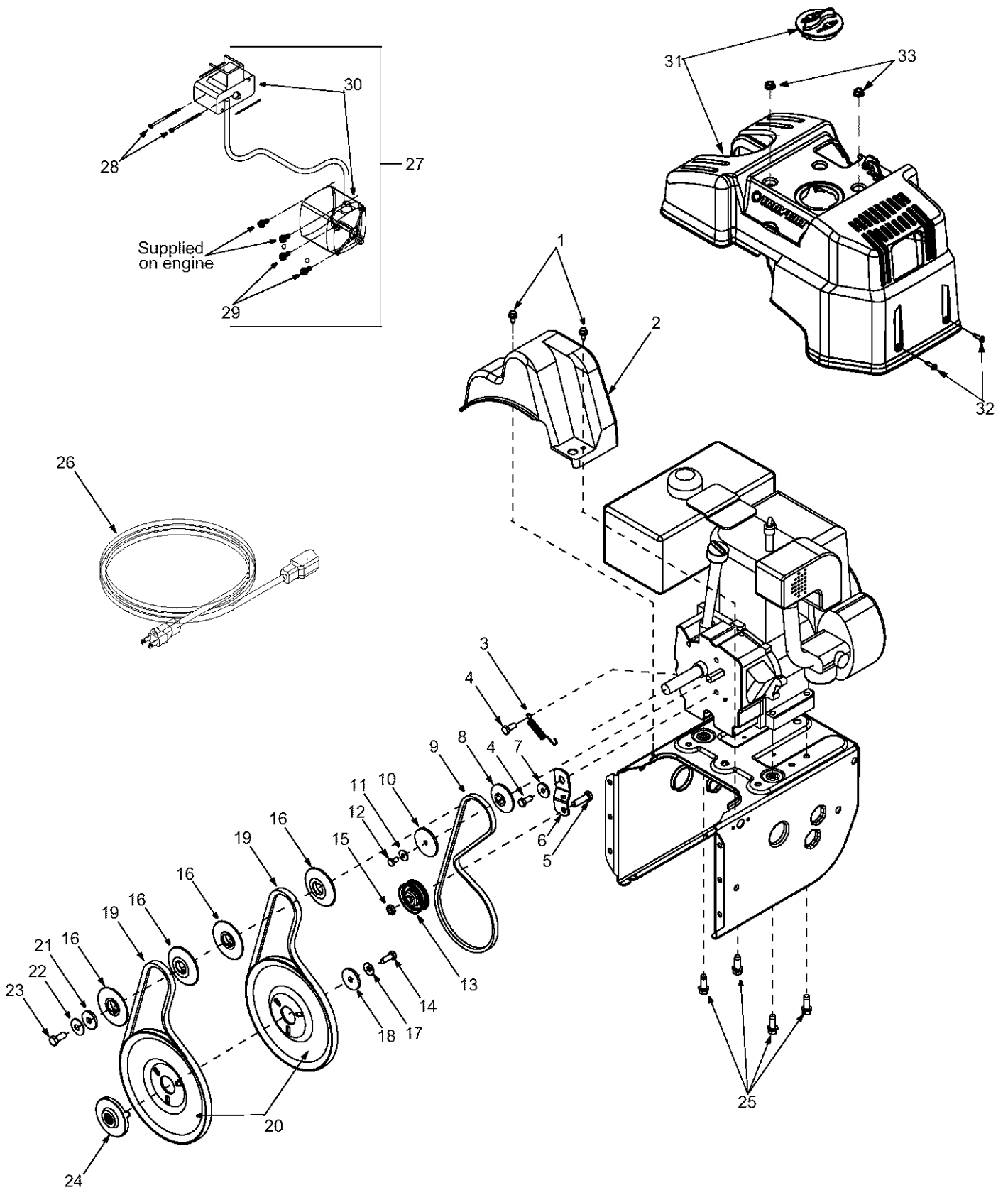

# Model 31AH7T74063

Ref. No.	Part No.	Part Description
1.	710-1652	Hex Washer Screw 1/4-20 x.625
2.	731-1324	Belt Cover
3.	732-0710	Extension Spring
4.	710-0627	Hex Screw 5/16-24 x.75
5.	710-3005	Hex Cap Screw 3/8-16 x 1.25
6.	05896A	Drive Clutch Idler Bracket
7.	748-0234	Shoulder Spacer
8.	756-0987	Pulley Half
9.	754-0346	V-Belt
10.	756-0986	Pulley Half
11.	736-0270	Bell Washer
12.	710-0230	Hex Cap Screw 1/4-28 x.50
13.	756-0313	Flat Idler
14.	710-1245B	Lock Hex Cap Screw 5/16-24
15.	712-0181	Lock Jam Nut 3/8-16
16.	756-0569	Pulley Half
17.	736-0242	Bell Washer
18.	736-0505	Flat Washer
19.	754-0430B	Belt
20.	756-0967	Auger Pulley
21.	736-0247	Flat Washer 3/8 x 1.25 OD
22.	736-0331	Bell Washer
23.	710-0696	Hex Cap Screw 3/8-24
24.	748-0360	Adapter Pulley
25.	710-0654A	Hex Screw 3/8-16 x 1.0
26.	629-0071	Extension Cord
27.	OEM-390-987	Electric Start Kit
28.	751428974	Hex Screw #6-32 x 2.5
29.	75142896	Hex Screw 1/4-20 x.500
30.	7511A173106	Electric Starter
31.	684-04014A	Engine Shroud Assembly
32.	710-04082	Screw #10-16 x.75
33.	712-3004A	Flange Lock Nut 5/16-18

**IMPORTANT:** For a proper working machine, use Factory Approved Parts.  
**V-BELTS** are specially designed to engage and disengage safely. A substitute (non OEM) V-Belt can be dangerous by not disengaging completely

# Model 31AH7T74063

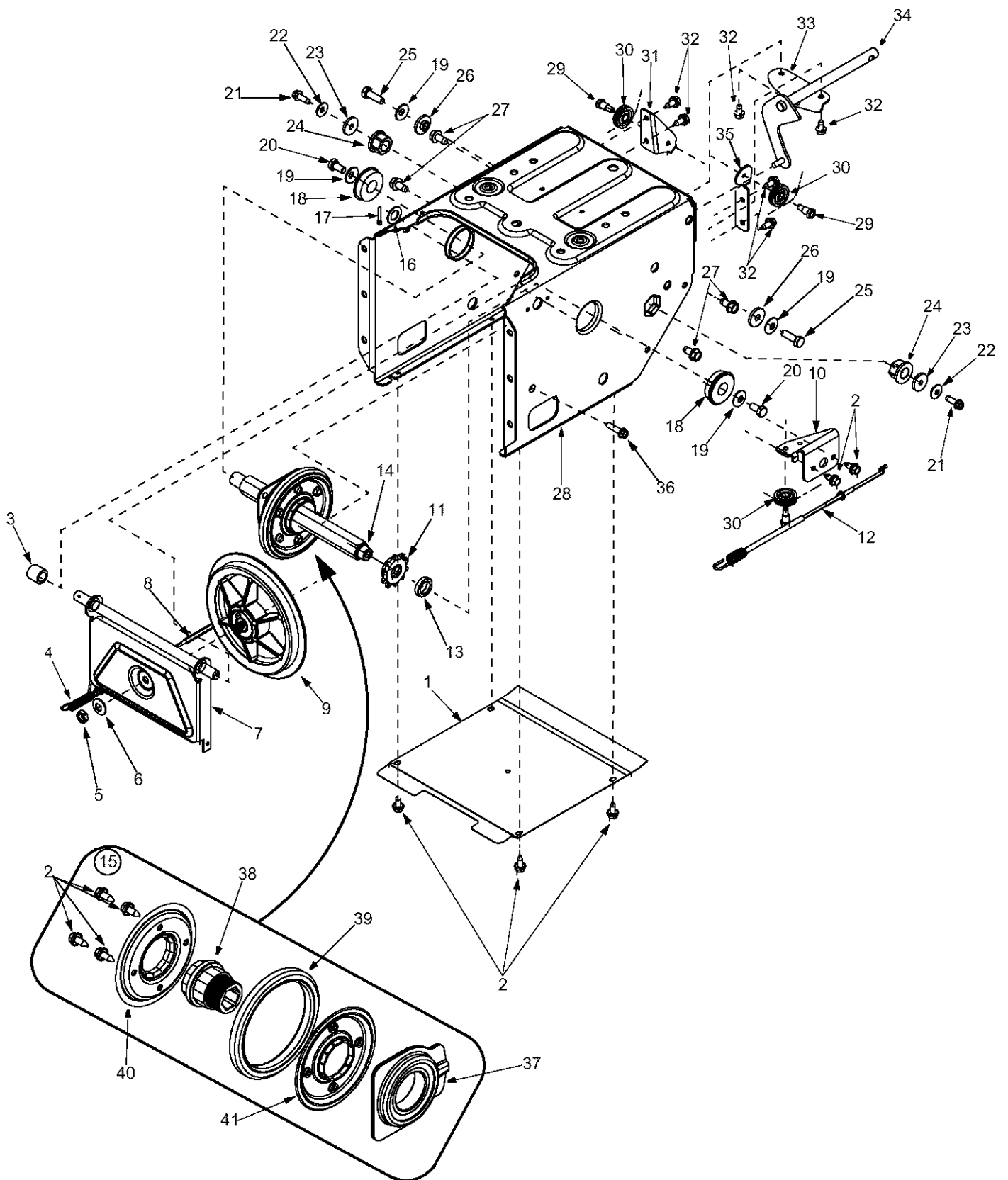



# Model 31AH7T74063

Ref. No.	Part No.	Part Description	Ref. No.	Part No.	Part Description
1.	784-5648	Frame Cover	22.	736-0270	Bell Washer.265 ID x.75 OD
2.	710-1652	Tap Screw 1/4-20 x.625	23.	736-0176	Flat Washer 1/4 ID x.93 OD
3.	748-0190	Spacer.508 ID x.75 OD	24.	741-1111	Hex Flange Bearing
4.	732-0264	Extension Spring	25.	710-0643	Hex Cap Screw 5/16-18 x 1"
5.	712-0711	Jam Nut 3/8-24	26.	748-0234	Shoulder Spacer
6.	736-0105	Bell Washer.401 ID x.87 OD	27.	710-0604A	Tap Screw 5/16-18 x.625
7.	684-0021	Friction Whl Support Bracket	28.	684-0031	Frame Assembly
8.	746-0898B	Drive Cable 39.88"	29.	738-0924	Hex Screw 1/4-28 x.375
9.	656-0012A	Friction Disc	30.	756-0625	Cable Roller
10.	784-5689A	Front Support Guide Bracket	31.	784-5688	Drive Cable Guide Bracket
11.	713-0413	10T Sprocket	32.	710-0599	Tap Screw 1/4-20 x.5
12.	746-0897	Auger Cable 44.75"	33.	784-5590	Shift Frame Bracket
13.	750-0997	Spacer.675 ID x 1" OD	34.	684-0014B	Shift Rod Assembly
14.	711-1042	Hex Track Shaft	35.	784-5687A	Auger Cable Guide Bracket
15.	684-0042C	Friction Wheel Assembly	36.	710-0809	Tap Screw 1/4-20 x 1.250
16.	736-0160	Flat Washer.536 ID x.93 OD	37.	618-0063A	Friction Wheel Bearing
17.	714-0474	Cotter Pin	38.	718-0301A	Friction Wheel Hub
18.	741-0563	Ball Bearing	39.	735-0243B	Friction Wheel Rubber
19.	736-0242	Bell Washer.34 ID x.872 OD	40.	790-00011	Friction Plate
20.	710-0538	Hex Cap Screw 5/16-18 x.625	41.	790-00010	Friction Plate
21.	710-0875	Tap Screw 1/4-20 x.75			

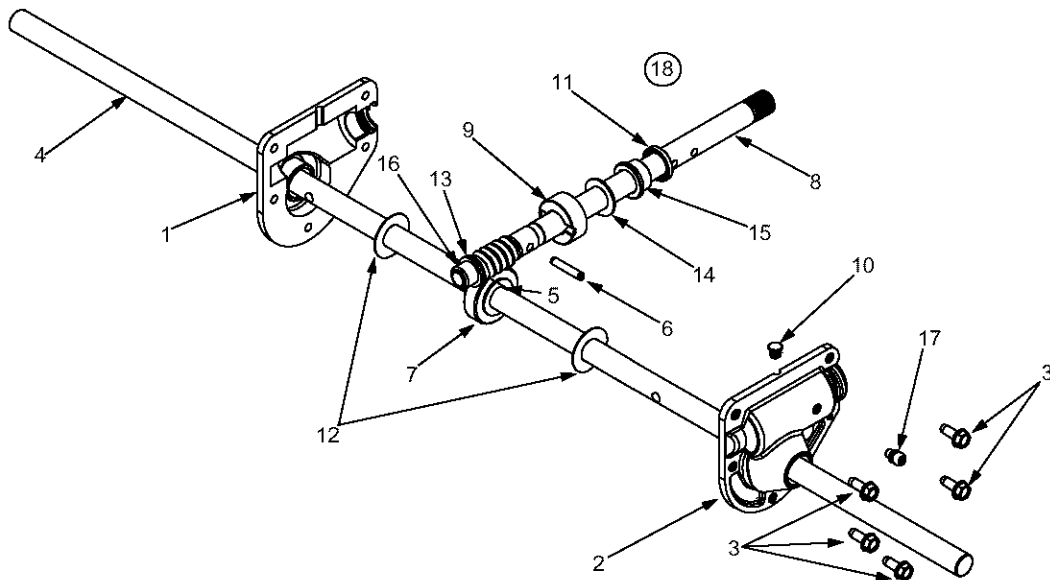

REF. NO.	PART NO.	DESCRIPTION	REF. NO.	PART NO.	DESCRIPTION
1.	618-0123	RH Housing	10.	721-0325	Grease Plug
2.	618-0418	LH Housing	11.	721-0327	Grease Seal
3.	710-0642	Self Tapping Screw, 1/4-20 x.75	12.	736-0351	Flat Washer,.76 x 1.5 x.030
4.	711-0910A	Spiral Axle 28"	13.	736-0369	Flat Washer,.508 x 1.0 x.020
5.	714-0161	Hi-Pro Key, 3/16 x 5/8	14.	736-0445	Flat Washer,.76 x 1.5 x.060
6.	715-0143	Spring Spiral Pin,.25 x 1.25	15.	741-0662	Flange Bearing,.75 x 1.0 x.59
7.	717-0528A	Worm Gear, 20-tooth	16.	741-0663	Flange Bearing,.503 ID x.75 OD
8.	717-0526	Worm Shaft	17.	737-3000	Lube Fitting, 3/16 Drive
9.	718-0186	Thrust Collar	18.	618-0416A	Gear Assembly Complete, 28"

# Model 31AH7T74063

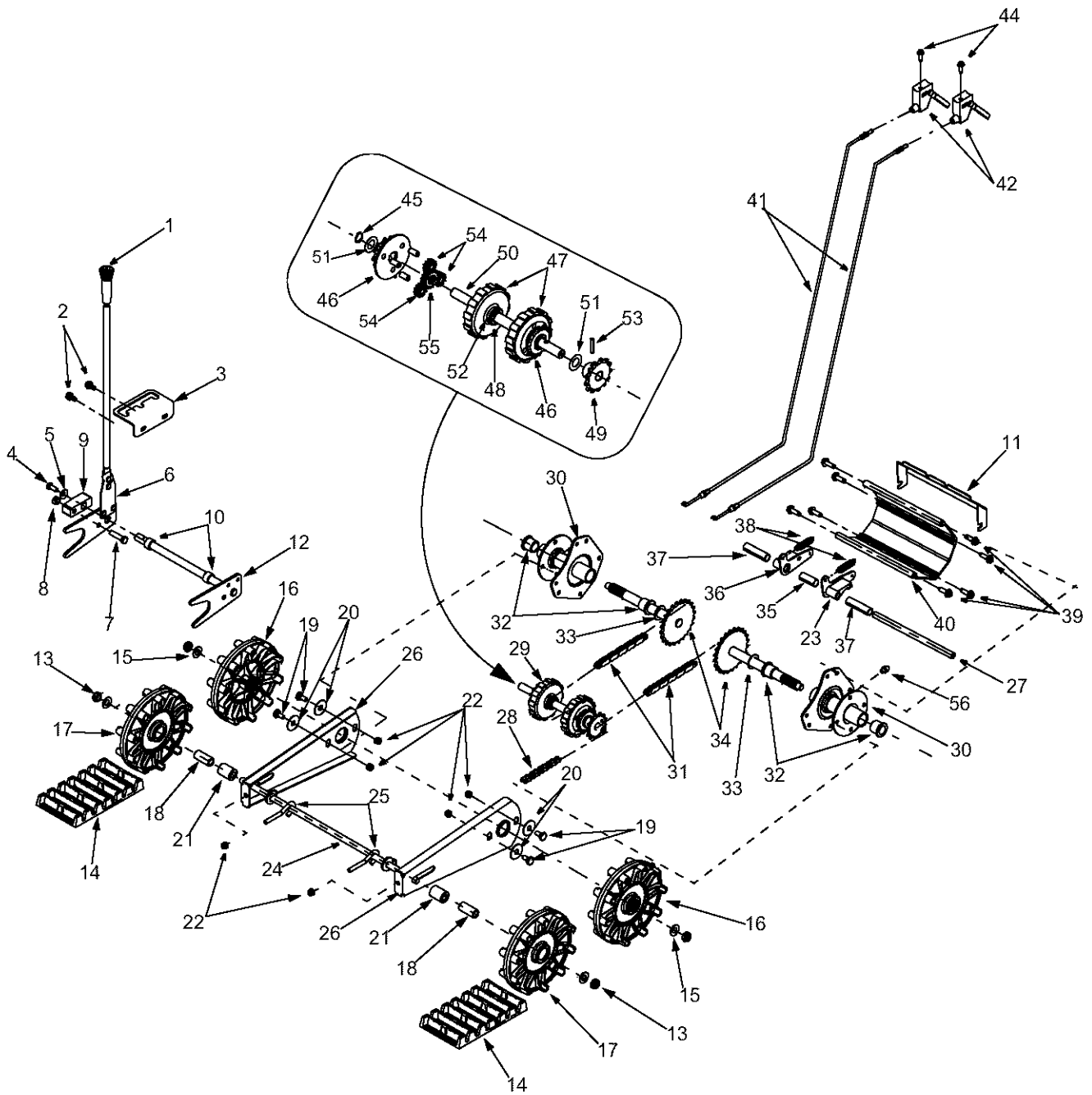

# Model 31AH7T74063

Ref. No.	Part No.	Part Description	Ref. No.	Part No.	Part Description
1.	720-0223	Grip	28.	713-0233	Chain
2.	710-0604A	Tap Screw, 5/16-18 x.625	29.	618-0169A	Track/Steering Shaft Assy
3.	784-5642	Track Lockout Plate	30.	683-0024	Track Hub Assy
4.	710-0157	Hex Cap Screw, 5/16-24 x.75	31.	713-0437	Chain
5.	736-0242	Bell Washer, .34 ID x.872 OD	32.	741-0339	Flange Bearing
6.	684-0038	Track Lock Handle Assembly	33.	736-0287	Flat Washer, .793 x 1.24 x.06
7.	710-0459A	Hex Cap Screw, 3/8-24 x 1.5	34.	611-0053	Axle Assembly
8.	712-0214	Hex Nut, 3/8-24	35.	750-0904	Spacer, .514 x.630 x 1.59
9.	748-0353A	Lift Shaft Drive	36.	618-0043	RH Dogg Assembly
10.	750-0547	Spacer, .628 ID x.875 OD x.5	37.	750-0903	Spacer, .514 x.630 x 2.44
11.	784-5609	Steering Cable Bracket	38.	732-0209	Extension Spring
12.	684-0009	Track Pivot Rod Assembly	39.	710-0602	Tap Screw, 5/16-18 x 1
13.	712-0346	Jam Nut, 1/2-20	40.	719-0295A	Track Housing
14.	731-1292	Snow Track	41.	746-0948	Steering Cable
15.	736-0272	Flat Washer, .5 x 1 x.06	42.	746-0950	Steering Trigger
16.	731-1538A	Track Drive Wheel	44.	710-1233	Screw, #10-24 x 1.375
17.	631-0032	Track Idler Wheel	45.	716-0114	Retaining Ring
18.	750-0995	Spacer, .51 ID x.75 OD x 1.67	46.	618-0046B	Carrier Assembly
19.	738-0140	Screw, .435 x.178-5/16 x.56	47.	717-1211B	Ring Gear
20.	736-0406	Flat Washer, .442 x 1.38 x.06	48.	716-0115	Retaining Ring
21.	750-0909	Spacer, .51 ID x 1 OD x 1.34	49.	713-0414	13-Tooth Sprocket
22.	712-0429	Hex Nut, 5/16-18	50.	711-0912	Track Steering Drive Shaft
23.	618-0044	LH Dogg Assembly	51.	736-0502	Flat Washer, .58 x 1.06 x.02
24.	684-0024	Idler Axle Assembly	52.	736-0336	Flat Washer, 5/8 x 1 x.03
25.	710-1231	Eye Bolt, 5/16-18 x 3	53.	715-0120	Spiral Pin, 3/16 x 1
26.	784-5639	Track Side Plate	54.	717-1209A	12-Tooth Gear
27.	711-0911	Actuator Shaft	55.	717-1210A	18-Tooth Gear

# MANUFACTURER'S LIMITED WARRANTY FOR:



The limited warranty set forth below is given by Troy-Bilt LLC with respect to new merchandise purchased and used in the United States, its possessions and territories.

"Troy-Bilt" warrants this product against defects in material and workmanship for a period of two (2) years commencing on the date of original purchase and will, at its option, repair or replace, free of charge, any part found to be defective in materials or workmanship. This limited warranty shall only apply if this product has been operated and maintained in accordance with the Operator's Manual furnished with the product, and has not been subject to misuse, abuse, commercial use, neglect, accident, improper maintenance, alteration, vandalism, theft, fire, water, or damage because of other peril or natural disaster. Damage resulting from the installation or use of any part, accessory or attachment not approved by Troy-Bilt for use with the product(s) covered by this manual will void your warranty as to any resulting damage.

Normal wear parts or components thereof are subject to separate terms as follows: All normal wear parts or component failures will be covered on the product for a period of 90 days regardless of cause. After 90 days, but within the two year period, normal wear part failures will be covered ONLY IF caused by defects in materials or workmanship of OTHER component parts. Normal wear parts and components include, but are not limited to: batteries, belts, blades, blade adapters, grass bags, rider deck wheels, seats, snow thrower skid shoes, shave plates, auger spiral rubber, and tires.

**HOW TO OBTAIN SERVICE:** Warranty service is available, WITH PROOF OF PURCHASE, through your local authorized service dealer. To locate the dealer in your area, check your Yellow Pages, or contact Troy-Bilt LLC at P.O. Box 361131, Cleveland, Ohio 44136-0019, or call 1-866-840-6483 or 1-330-558-7220, or log on to our Web site at [www.troybilt.com](http://www.troybilt.com).

This limited warranty does not provide coverage in the following cases:

- a. The engine or component parts thereof. These items may carry a separate manufacturer's warranty. Refer to applicable manufacturer's warranty for terms and conditions.
- b. Log splitter pumps, valves, and cylinders have a separate one year warranty.
- c. Routine maintenance items such as lubricants, filters, blade sharpening, tune-ups, brake adjustments, clutch adjustments, deck adjustments, and normal deterioration of the exterior finish due to use or exposure.

- d. Troy-Bilt does not extend any warranty for products sold or exported outside of the United States, its possessions and territories, except those sold through Troy-Bilt's authorized channels of export distribution.
- e. Replacement parts that are not genuine Troy-Bilt parts.
- f. Service completed by someone other than an authorized service dealer.
- g. Transportation charges and service calls.

**No implied warranty, including any implied warranty of merchantability of fitness for a particular purpose, applies after the applicable period of express written warranty above as to the parts as identified. No other express warranty, whether written or oral, except as mentioned above, given by any person or entity, including a dealer or retailer, with respect to any product, shall bind Troy-Bilt. During the period of the warranty, the exclusive remedy is repair or replacement of the product as set forth above.**

**The provisions as set forth in this warranty provide the sole and exclusive remedy arising from the sale. Troy-Bilt shall not be liable for incidental or consequential loss or damage including, without limitation, expenses incurred for substitute or replacement lawn care services or for rental expenses to temporarily replace a warranted product.**

Some states do not allow the exclusion or limitation of incidental or consequential damages, or limitations on how long an implied warranty lasts, so the above exclusions or limitations may not apply to you.

In no event shall recovery of any kind be greater than the amount of the purchase price of the product sold. **Alteration of safety features of the product shall void this warranty.** You assume the risk and liability for loss, damage, or injury to you and your property and/or to others and their property arising out of the misuse or inability to use the product.

This limited warranty shall not extend to anyone other than the original purchaser or to the person for whom it was purchased as a gift.

**HOW STATE LAW RELATES TO THIS WARRANTY:** This limited warranty gives you specific legal rights, and you may also have other rights which vary from state to state.

**IMPORTANT:** Owner must present Original Proof of Purchase to obtain warranty coverage.

**Troy-Bilt LLC, P.O. BOX 361131 CLEVELAND, OHIO 44136-0019; Phone: 1-866-840-6483, 1-330-558-7220**