

# OPERATOR'S MANUAL

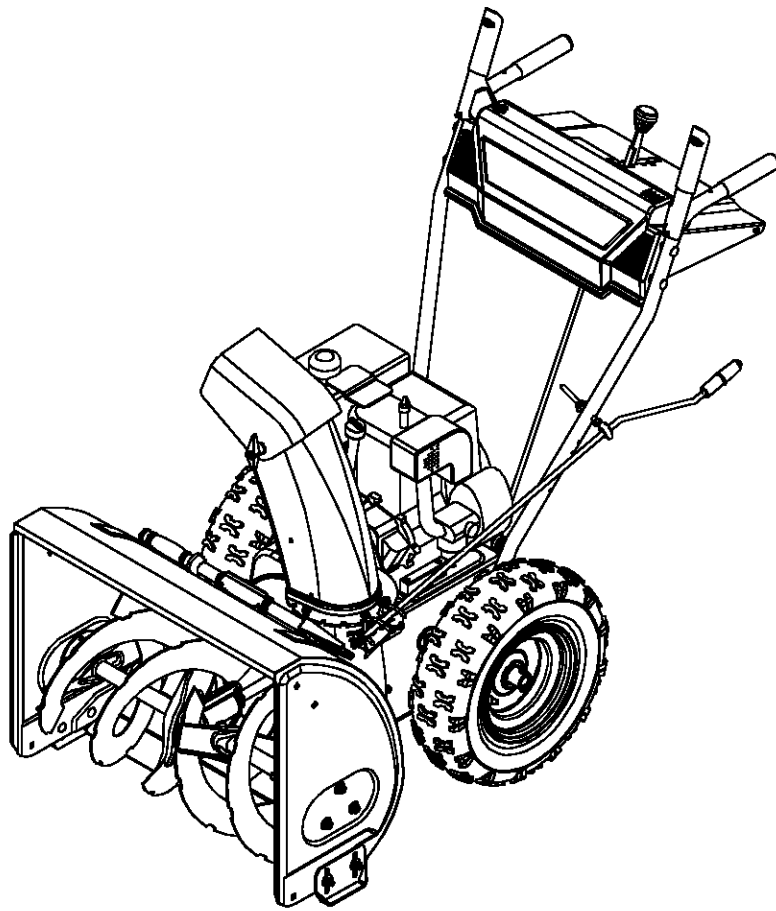

## SNOW THROWER

### MODELS

E600E, S610E

E640F, E660F

E660G, E6C0F

## IMPORTANT: READ SAFETY RULES AND INSTRUCTIONS CAREFULLY

**Warning:** This unit is equipped with an internal combustion engine and should not be used on or near any unimproved forest-covered, brush-covered or grass-covered land unless the engine's exhaust system is equipped with a spark arrester meeting applicable local or state laws (if any). If a spark arrester is used, it should be maintained in effective working order by the operator. In the State of California the above is required by law (Section 4442 of the California Public Resources Code). Other states may have similar laws. Federal laws apply on federal lands. A spark arrester for the muffler is available through your nearest engine authorized service dealer or contact the service department, P.O. Box 361131 Cleveland, Ohio 44136-9722.

**MTD LLC, P.O. BOX 361131 CLEVELAND, OHIO 44136-9722**

FORM NO. 769-00292  
(5/2002)

PRINTED IN U.S.A.

# TABLE OF CONTENTS

Content	Page
Important Safe Operation Practices .....	3
Loose Parts & Hardware Pack.....	5
Assembling Your Snow Thrower .....	7
Know Your Snow Thrower .....	10
Operating Your Snow Thrower .....	11
Making Adjustments.....	13
Maintaining Your Snow Thrower .....	14
Service .....	15
Off-Season Storage.....	17
Troubleshooting .....	18
Parts List .....	19

## FINDING MODEL NUMBER

This Operator's Manual is an important part of your new snow thrower. It will help you assemble, prepare and maintain the unit for best performance. Please read and understand what it says.



**Before you start assembling your new equipment**, please locate the model plate on the equipment and copy the information from it in the space provided below. The information on the model plate is very important if you need help from our Customer Support Department or an authorized dealer.

You can locate the model number by standing behind the unit in the operating position and looking down at the rear frame below the engine. A sample model plate is explained below. For future reference, please copy the model number and the serial number of the equipment in the space below.

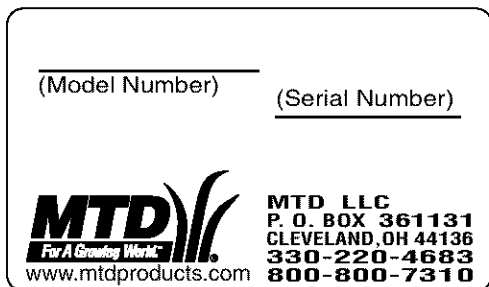

Copy the model number here: \_\_\_\_\_

Copy the serial number here: \_\_\_\_\_

## ENGINE INFORMATION

The engine manufacturer is responsible for all engine-related issues with regard to performance, power-rating, specifications, warranty and service. Please refer to the engine manufacturer's Owner's/Operator's Manual packed separately with your unit for more information.

## CALLING CUSTOMER SUPPORT

**Please do NOT return the unit to the retailer from which it was purchased, without first contacting Customer Support.**

Should you have difficulty assembling this product or have any questions regarding the controls, operation or maintenance of this unit, please call the Customer Support Department.



Call **1-(330) 220-4MTD (4683)** or **1-(800) 800-7310** to reach a Customer Support representative. Please have your unit's model number and serial number ready when you call. See previous section to locate this information. You will be asked to enter the serial number in order to process your call.

For more details about your unit, visit our website at [www.mtdproducts.com](http://www.mtdproducts.com)

---

## SECTION 1: IMPORTANT SAFE OPERATION PRACTICES



This symbol points out important safety instructions, which if not followed, could endanger the personal safety and/or property of yourself and others. Read and follow all instructions in this manual before attempting to operate this machine. Failure to comply with these instructions may result in personal injury. When you see this symbol—**heed its warning.**



**WARNING:** Engine Exhaust, some of its constituents, and certain vehicle components contain or emit chemicals known to the State of California to cause cancer, birth defects or other reproductive harm.



**DANGER:** This machine was built to be operated according to the rules for safe operation in this manual. As with any type of power equipment, carelessness or error on the part of the operator can result in serious injury. This machine is capable of amputating hands and feet and throwing objects. Failure to observe the following safety instructions could result in serious injury or death.

### TRAINING

1. Read, understand, and follow all instructions on the machine and in the manual(s) before attempting to assemble and operate. Keep this manual in a safe place for future and regular reference and for ordering replacement parts.
2. Be familiar with all controls and their proper operation. Know how to stop the machine and disengage them quickly.
3. Never allow children under 14 years old to operate this machine. Children 14 years old and over should read and understand the operation instructions and safety rules in this manual and should be trained and supervised by a parent.
4. Never allow adults to operate this machine without proper instruction.
5. Thrown objects can cause serious personal injury. Plan your snow-throwing pattern to avoid discharge of material toward roads, bystanders and the like.
6. Keep bystanders, helpers, pets and children at least 75 feet from the machine while it is in operation. Stop machine if anyone enters the area.
7. Exercise caution to avoid slipping or falling, especially when operating in reverse.
7. Never attempt to make any adjustments while engine is running, except where specifically recommended in the operator's manual.
8. Let engine and machine adjust to outdoor temperature before starting to clear snow.
9. To avoid personal injury or property damage use extreme care in handling gasoline. Gasoline is extremely flammable and the vapors are explosive. Serious personal injury can occur when gasoline is spilled on yourself or your clothes, which can ignite. Wash your skin and change clothes immediately.
  - a. Use only an approved gasoline container.
  - b. Extinguish all cigarettes, cigars, pipes and other sources of ignition.
  - c. Never fuel machine indoors.
  - d. Never remove gas cap or add fuel while the engine is hot or running.
  - e. Allow engine to cool at least two minutes before refueling.
  - f. Never over fill fuel tank. Fill tank to no more than ½ inch below bottom of filler neck to provide space for fuel expansion.
  - g. Replace gasoline cap and tighten securely.
  - h. If gasoline is spilled, wipe it off the engine and equipment. Move machine to another area. Wait 5 minutes before starting the engine.
  - i. Never store the machine or fuel container inside where there is an open flame, spark or pilot light (e.g. furnace, water heater, space heater, clothes dryer etc.).
  - j. Allow machine to cool at least 5 minutes before storing.

### PREPARATION

1. Thoroughly inspect the area where the equipment is to be used. Remove all doormats, newspapers, sleds, boards, wires and other foreign objects, which could be tripped over or thrown by the auger/impeller.
2. Always wear safety glasses or eye shields during operation and while performing an adjustment or repair to protect your eyes. Thrown objects which ricochet can cause serious injury to the eyes.
3. Do not operate without wearing adequate winter outer garments. Do not wear jewelry, long scarves or other loose clothing, which could become entangled in moving parts. Wear footwear which will improve footing on slippery surfaces.
4. Use a grounded three-wire extension cord and receptacle for all units with electric start engines.
5. Adjust collector housing height to clear gravel or crushed rock surfaces.
6. Disengage all clutch levers before starting the engine.

### OPERATION

1. Do not put hands or feet near rotating parts, in the auger/impeller housing or discharge chute. Contact with the rotating parts can amputate hands and feet.
2. The auger/impeller clutch lever is a safety device. Never bypass its operation. Doing so makes the machine unsafe and may cause personal injury.
3. The clutch levers must operate easily in both directions and automatically return to the disengaged position when released.

4. Never operate with a missing or damaged discharge chute. Keep all safety devices in place and working.
5. Never run an engine indoors or in a poorly ventilated area. Engine exhaust contains carbon monoxide, an odorless and deadly gas.
6. Do not operate machine while under the influence of alcohol or drugs.
7. Muffler and engine become hot and can cause a burn. Do not touch.
8. Exercise extreme caution when operating on or crossing gravel surfaces. Stay alert for hidden hazards or traffic.
9. Exercise caution when changing direction and while operating on slopes.
10. Plan your snow-throwing pattern to avoid discharge towards windows, walls, cars etc. Thus, avoiding possible property damage or personal injury caused by a ricochet.
11. Never direct discharge at children, bystanders and pets or allow anyone in front of the machine.
12. Do not overload machine capacity by attempting to clear snow at too fast of a rate.
13. Never operate this machine without good visibility or light. Always be sure of your footing and keep a firm hold on the handles. Walk, never run.
14. Disengage power to the auger/impeller when transporting or not in use.
15. Never operate machine at high transport speeds on slippery surfaces. Look down and behind and use care when in reverse.
16. If the machine should start to vibrate abnormally, stop the engine, disconnect the spark plug wire and ground it against the engine. Inspect thoroughly for damage. Repair any damage before starting and operating.
17. Disengage all clutch levers and stop engine before you leave the operating position (behind the handles). Wait until the auger/impeller comes to a complete stop before unclogging the discharge chute, making any adjustments, or inspections.
18. Never put your hand in the discharge or collector openings. Always use the clean-out tool provided to unclog the discharge opening. Do not unclog discharge chute while engine is running. Shut off engine and remain behind handles until all moving parts have stopped before unclogging.
19. Use only attachments and accessories approved by the manufacturer (e.g. wheel weights, tire chains, cabs etc.).
20. If situations occur which are not covered in this manual, use care and good judgment.

Contact your dealer or telephone 1-800-800-7310 for assistance and the name of your nearest servicing dealer.

## MAINTENANCE AND STORAGE

1. Never tamper with safety devices. Check their proper operation regularly. Refer to the maintenance and adjustment sections of this manual.
2. Before cleaning, repairing or inspecting machine disengage all clutch levers and stop engine. Wait until the auger/impeller come to a complete stop. Disconnect the spark plug wire and ground against the engine to prevent unintended starting.
3. Check bolts and screws for proper tightness at frequent intervals to keep the machine in safe working condition. Also, visually inspect machine for any damage.
4. Do not change the engine governor setting or over-speed the engine. The governor controls the maximum safe operating speed of the engine.
5. Snow thrower shave plates and skid shoes are subject to wear and damage. For your safety protection, frequently check all components and replace with original equipment manufacturer's (OEM) parts only. "Use of parts which do not meet the original equipment specifications may lead to improper performance and compromise safety!"
6. Check clutch controls periodically to verify they engage and disengage properly and adjust, if necessary. Refer to the adjustment section in this operator's manual for instructions.
7. Maintain or replace safety and instruction labels, as necessary.
8. Observe proper disposal laws and regulations for gas, oil, etc. to protect the environment.
9. Prior to storing, run machine a few minutes to clear snow from machine and prevent freeze up of auger/impeller.
10. Never store the machine or fuel container inside where there is an open flame, spark or pilot light such as a water heater, furnace, clothes dryer etc.
11. Always refer to the operator's manual for proper instructions on off-season storage.





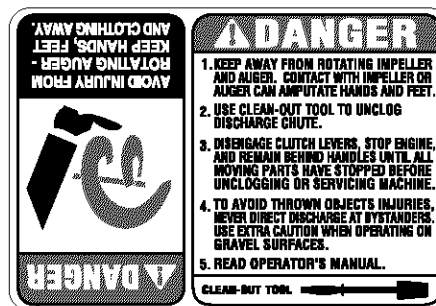



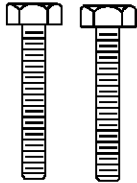
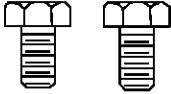
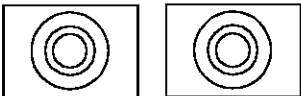

### WARNING — YOUR RESPONSIBILITY:

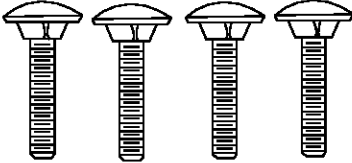
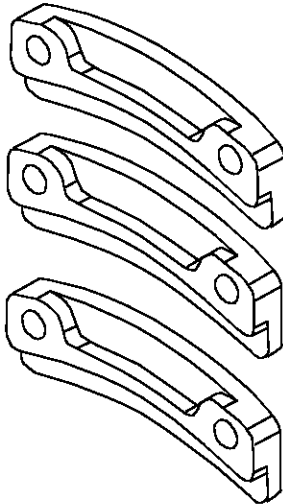
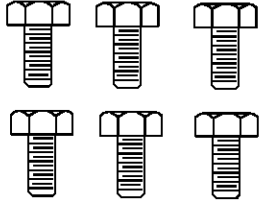
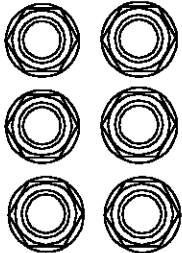
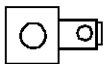
Restrict the use of this power machine to persons who read, understand and follow the warnings and instructions in this manual and on the machine. The safety labels are shown below for your reference.

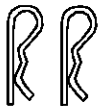

# Contents Of Hardware Pack

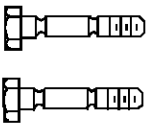
Lay out the hardware according to the illustration for identification purposes. Part numbers are shown in parentheses. (Hardware pack may contain extra items which are not used on your unit.)

<p><b>A ATTACHING THE HANDLES</b></p>  <p>Hex Bolts 5/16-18 x 2" (710-04039)</p>  <p>Hex Bolts 5/16-18 x 3/4" (710-3008)</p> <p>Handle Tabs (784-5599)</p>  <p>Lock Washers 5/16" I.D. (736-0119)</p>  <p>Carriage Bolts 5/16-18 x 1-1/2" (710-0262)</p>  <p>Cupped Washers 5/16" I.D. (736-0242)</p> <p>Hex Nuts 5/16" Thread (712-3068)</p>	<p><b>C ATTACHING THE CHUTE ASSEMBLY</b></p>  <p>Chute Flange Keepers (731-0851A)</p>  <p>Hex Bolts (710-3015) 1/4-20 x 3/4"</p>  <p>Hex Lock Nuts 1/4-20 Thread (712-3027)</p>
<p><b>B ATTACHING THE SHIFT ROD AND CLUTCH CABLES</b></p>  <p>Ferrule (711-0677)</p>  <p>Flat Washers 5/16" I.D. x 5/8" O.D. (736-0275)</p>  <p>Hair Pin Clip (714-0104)</p>	<p><b>D ATTACHING THE CHUTE DIRECTIONAL CONTROL</b></p>  <p>Flat Washers 3/8" I.D. x 5/8" O.D. (736-0185)</p> <p>Hex Nut 5/16" Thread (712-3010)</p>  <p>Cupped Washers 5/16" I.D. (736-0242)</p>  <p>Hair Pin Clip (714-0104)</p>
<p><b>E AUGER SHEAR BOLTS*</b></p>  <p>Shear Bolts (710-0890A)</p>  <p>Hex Lock Nuts 5/16" Thread (712-0429)</p>	<p><b>F "Z" FITTING NUTS</b></p> <p>Jam Nuts #10-24 Thread (712-0121)</p> 

\* The augers are secured to the spiral shaft with two shear bolts and hex lock nuts. If you hit a hard foreign object or an ice jam, the snow thrower is designed so that the bolts may shear. These two spare shear bolts and nuts are provided for your convenience.

**IMPORTANT:** NEVER replace the auger shear bolts with standard hex bolts. Any damage to the auger gearbox or other components as a result of doing so will NOT be covered by your snow thrower's warranty.

## SECTION 2: ASSEMBLING YOUR SNOW THROWER

### Loose Parts

Figure 1 shows parts of the snow thrower packed loose in the carton. You will need these parts along with hardware from the hardware pack, illustrated on the next page, to assemble the equipment. Identify the loose parts before proceeding to assemble.

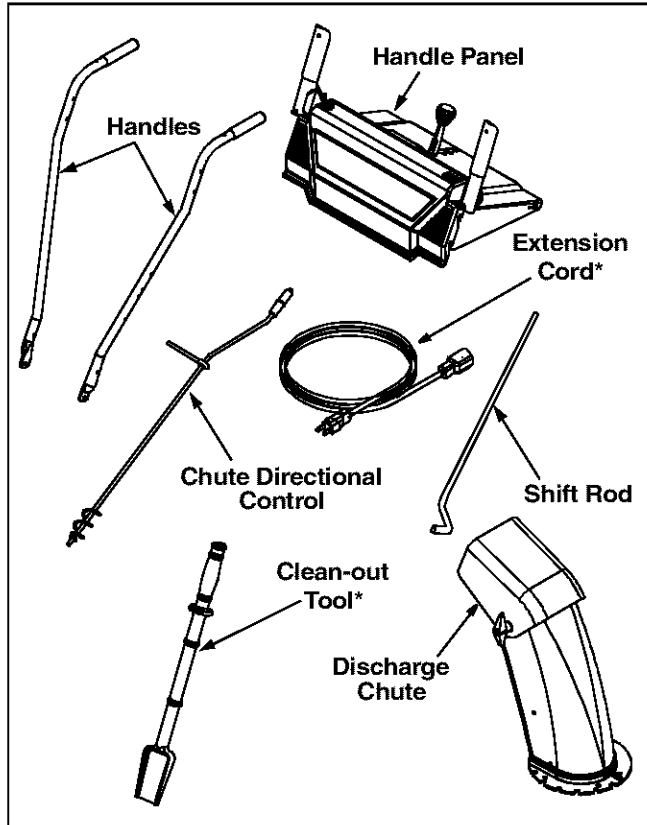

Figure 1

1. Right and Left Handles
2. Handle Panel Assembly
3. Chute Assembly
4. Chute Directional Control Assembly
5. Shift Rod
6. Hardware Pack
7. Clean-out Tool\*
8. Extension Cord\*

\* This item is fastened with a cable tie to the rear of the Auger Housing at the factory. Cut the cable tie before operating the snow thrower.

### Tools Required For Assembly

1. Pair of pliers
2. Two adjustable wrenches



**WARNING:** Disconnect spark plug wire and ground it against the engine to prevent unintended starting.

**NOTE:** All references to right or left side of the snow thrower are determined from behind the unit in the operating position. The "operator's position" is defined as standing directly behind the snow thrower, facing the handle panel.

**Assembly Tips:** For convenience in assembly, remove the chute from the carton and lay it on top of the engine. Do not unwrap the chute till you have installed the handle panel and the clutch cables.

### Attaching Handle

(Hardware Group A)

- Place right handle in position against the snow thrower so the flat side of the handle is against the snow thrower. Secure bottom hole in handle to snow thrower using 3/4" hex bolt and lock washer. Do not tighten at this time. See Figure 2.

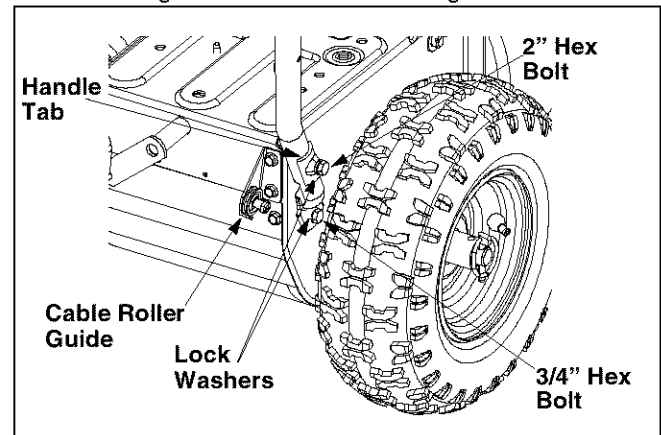

Figure 2

- Place handle tab over the upper hole on the handle so the curve in the handle tab matches the curve of the handle. See Figure 2. Secure to the snow thrower using 2" hex bolt and lock washer; do not tighten at this time. Repeat on the other side. Do not tighten at this time.
- Place the handle panel in position between the two handles. To hold the handle panel in place, depress both controls against the handles. While continuing to hold the right control, release the left control (the auger control lock will keep left control engaged). See Figure 3.
- Fasten right side of the handle panel by inserting two carriage bolts through handle and handle panel (bolts must go through both the plastic and metal parts of the handle panel). See Figure 3. Secure with cupped washers (cupped side against handle panel) and lock nuts.
- Repeat on the other side.

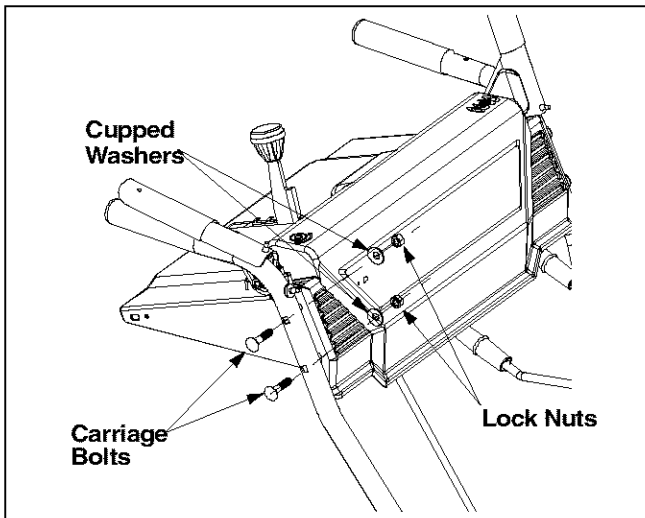

Figure 3

- Tighten the four hex bolts used earlier to attach bottom of the handles to the snow thrower frame. See Figure 2.

## Attaching Control Cables

"Z" fittings with jam nuts are inserted in each control lever (on the handle panel) at the factory. To attach the cables to the "Z" fittings, proceed as follows:

**NOTE:** Two extra jam nuts are included in the hardware pack (Group F) in the event either are lost during shipping.

- Thread the jam nuts all the way up each of the "Z" fittings, toward the handle panel. See Figure 4.

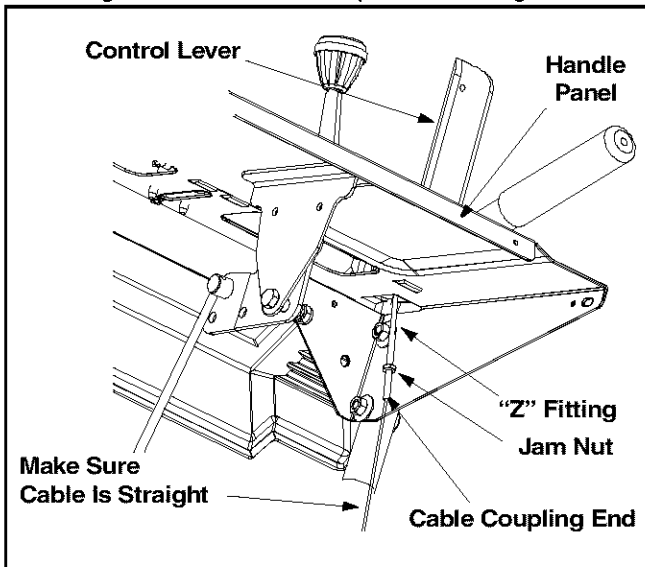

Figure 4

- Make certain all cables are in the grooves of the cable roller guides located in the lower rear of the unit, one on each side. See Figure 2.

- Thread the coupling end of the cable onto the threaded portion of the "Z" fitting until the rubber bumper (located on the underside of the clutch lever) only lightly contacts the upper handle.

**IMPORTANT:** The cable should have very little slack, but should NOT be tight. An overtightened cable may prohibit the auger and drive from disengaging.



**WARNING:** Over-tightening the cable may prohibit the auger and drive from disengaging and compromise the safety of the snow thrower. Do NOT overtighten the cable.

- Once properly adjusted, tighten the jam nut against the coupling end of the cable to lock it in position.

**NOTE:** Refer to **Auger Control Test** on page 12 prior to operating your snow thrower. Read and follow all instructions carefully and perform all adjustments to verify your snow thrower is operating safely and properly.

## Attaching Chute Assembly

(Hardware Group C)

- Place the chute assembly over the chute opening with the chute facing front of the unit.

**NOTE:** Make sure that the chute cables are straightened while assembling the chute.

- Place the chute flange keeper (flat side down) beneath lip of chute assembly as shown in Figure 5. You will find the chute flange keepers in group C of the hardware pack.
- Insert 1/4-20 x .75" hex bolt and flange nut (group C of the hardware pack) up through chute flange keeper and chute assembly as shown in Figure 5. Do not tighten at this time. Rotate chute to install all the flange keepers.

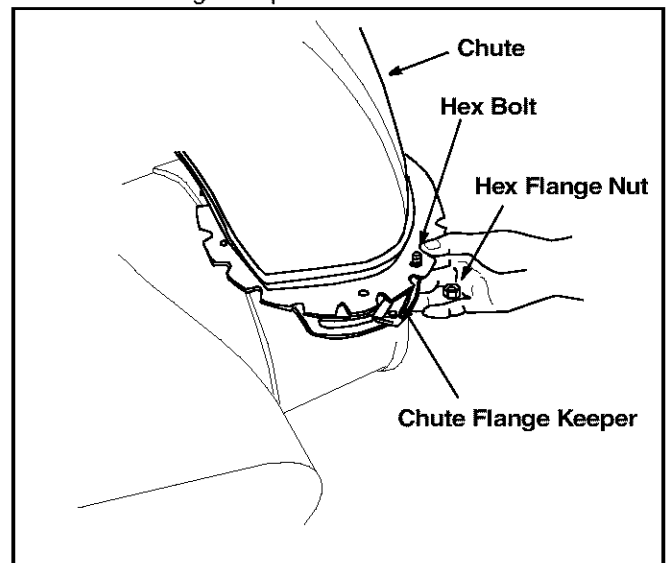

Figure 5

- After assembling all three chute flange keepers, tighten, then back off 1/4 turn to allow easier movement of the chute. Use two 7/16" wrenches.

## Attaching Chute Directional Control

(Hardware Group D)

- Thread one hex nut about halfway onto eye bolt on the chute directional control.
- Insert eye bolt through the hole provided in the left handle. See Figure 6.
- Secure with cupped washer (cupped side against the handle) and other hex nut. Do not tighten until after attaching the other end of the chute directional control.

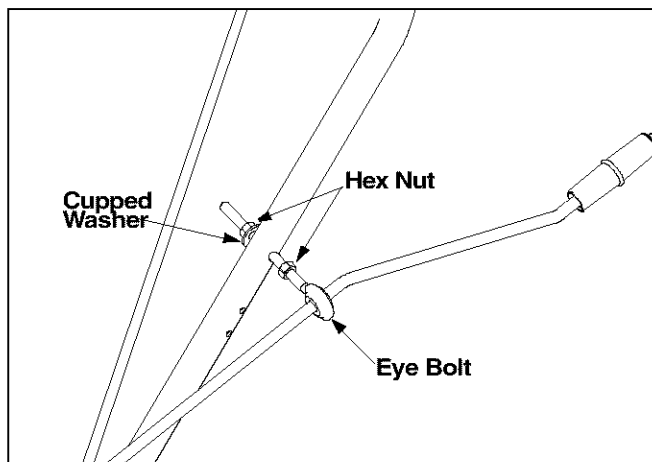

Figure 6

- To align the spiral on the chute directional control, you may have to loosen the carriage bolts and hex lock nuts securing lower chute bracket to the extension on the left side of the chute assembly. See Figure 7.

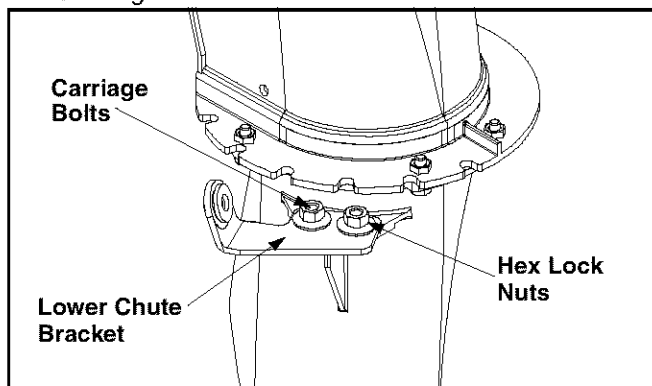

Figure 7

- Place one flat washer on the end of the chute directional control, then insert the end of the control into the hole in the plastic bushing in the lower chute bracket.
- Place another flat washer on the end of the chute directional control, and insert hairpin clip into hole in the end of control. See Figure 8.

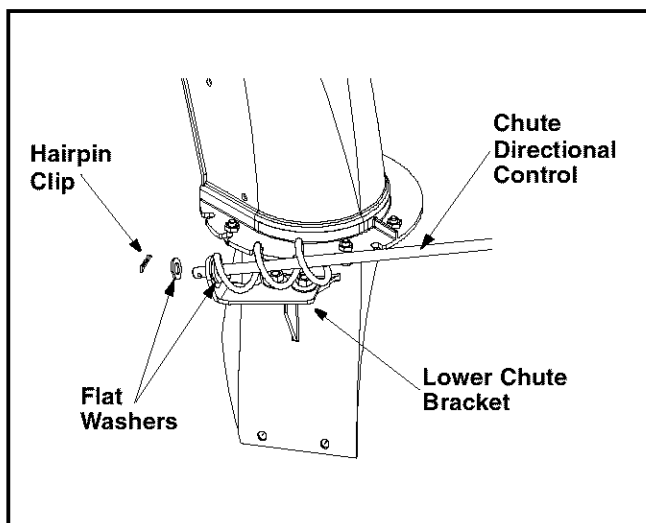

Figure 8

- Adjust the chute bracket so that the spiral on the chute directional control fully engages the teeth on the chute assembly.
- Tighten nuts on the lower chute bracket securely.
- Tighten hex nut on the eye bolt on chute directional control.

## Attaching Shift Rod

(Hardware Group B)

**IMPORTANT:** Attach the shift rod and clutch cables as follows. Then check the adjustments and make any final adjustments necessary before operating your snow thrower. Failure to properly follow the instructions may cause damage to the snow thrower.

- Place the shift lever (on the handle panel) in the sixth (6) speed position (all the way forward).
- Place the bent end of the shift rod into the hole in the shift arm assembly. Secure with flat washer and hairpin clip. See Figure 9.
- Start threading the ferrule onto the other end of the shift rod. Push down on the shift rod (and shift arm assembly) as far as it will go.
- Thread the ferrule onto the shift rod until the ferrule lines up with the upper hole in the shift lever (beneath the handle panel). Insert the ferrule into the upper hole in the shift lever from the left side when adjustment is correct. Secure with flat washer and hairpin clip.
- Check for correct adjustment of the shift rod as instructed in the under the heading **Traction Control and Shift Lever** on page 13 before operating the snow thrower.



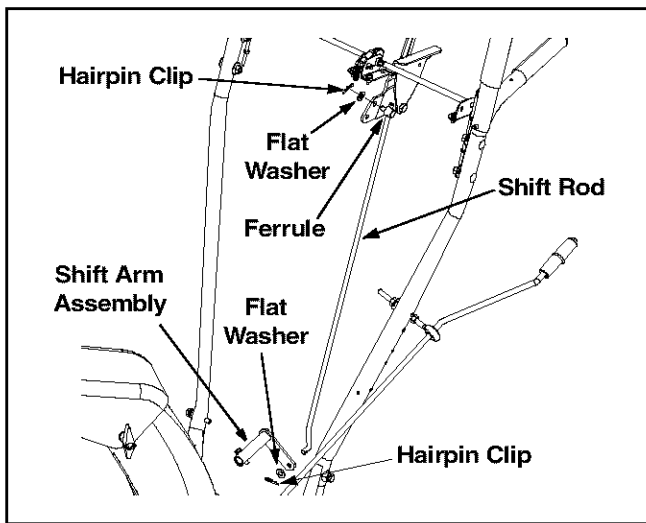

Figure 9

## Lamp Wiring

**NOTE:** A lamp is an optional feature of some model snow throwers and is NOT standard equipment. On models so equipped, a lamp will either be installed on the dash panel at the factory OR packaged separately as a Kit within the carton, depending on the model.

- If so equipped, wrap the wire from the lamp down the right handle until the wire can be plugged into the alternator lead wire located under the fuel tank. See Figure 10. Lamp wire must not interfere with any controls or cables.

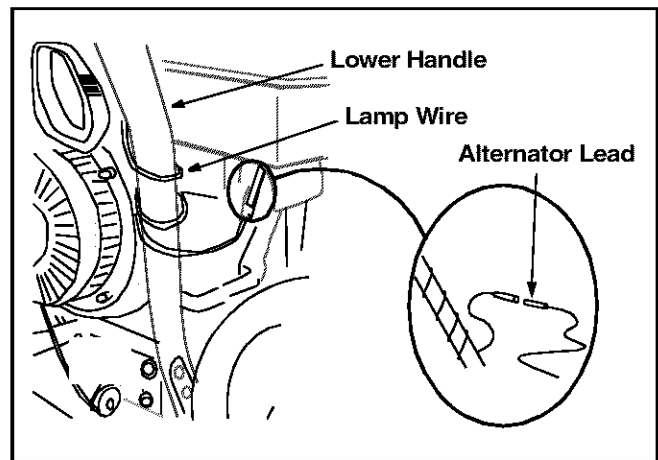

Figure 10

If your unit is not equipped with a lamp, contact Customer Support as instructed on page 2 for information regarding price and availability.

Snow Thrower Model	Electric Light Kit
E600E, E640F, E6C0F,	OEM-390-255
E660F & E660G	

**NOTE:** The engine found on snow thrower model S610E is NOT equipped with an alternator and therefore can NOT accept a light kit.

## Gas and Oil

After assembly, service engine with gasoline, and check oil level as instructed in the engine manual.

# SECTION 3: KNOW YOUR SNOW THROWER

## Operating Controls



**WARNING:** Be familiar with all controls and their proper operation. Know how to stop the machine and disengage them quickly.

### Shift Lever

The shift lever is located in the center of the handle panel. The shift lever may be moved into one of eight positions. Run engine with throttle in the fast position. Use the shift lever to determine ground speed.

**Forward:** There are six speeds. Position one (1) is the slowest. Position six (6) is the fastest.

**Reverse:** There are two reverse (R) speeds R1 and R2. The "R2" closest to the operator (all the way back) is the faster of the two.

### Auger Control

The auger control is located on the left handle. Squeeze the control to engage the augers; release to stop the augers. The traction control must also be released.

### Traction / Auger Control Lock

The traction control is located on the right handle. Squeeze the control to engage the wheel drive. Release to stop.

This same control also locks the auger control so you can turn the chute directional control without interrupting the snow throwing process. If the auger control is engaged with the traction control engaged, the operator can release the auger control (on the left handle) and the augers will remain engaged. Release the traction control to stop both the augers and wheel drive (auger control must also be released).

### Chute Directional Control

The chute directional control is located on left hand side of the snow thrower. To change the direction in which snow is thrown, rotate chute directional control as follows:

- Clockwise to discharge to the left.
- Counterclockwise to discharge to the right.

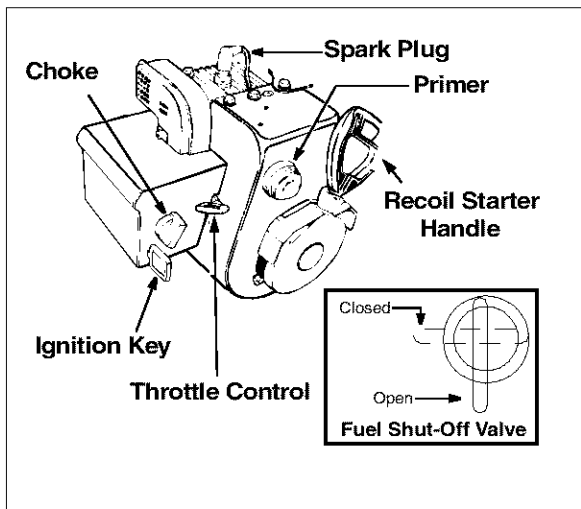
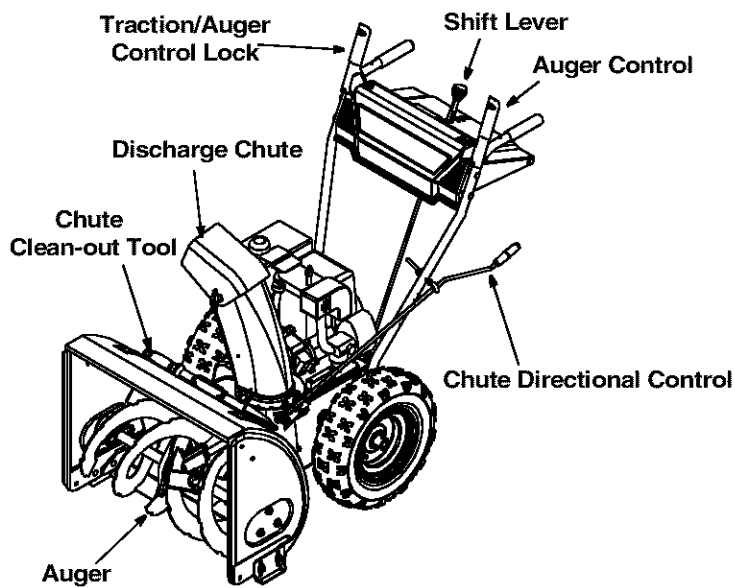

Figure 11

### Chute Clean-out Tool



**WARNING:** Never use your hand to clear a clogged discharge chute. Shut off engine and remain behind handles until all moving parts have stopped before unclogging.

The chute clean-out tool (see Figure 11) is designed to clear a clogged discharge chute. Refer to **Operating Your Snow Thrower** on page 12 for detailed instructions on how to properly use the chute clean-out tool.

### Ignition Key

The ignition key must be inserted in the switch in order for the engine to start. Remove the ignition key when the snow thrower is not in use.

**NOTE:** Do NOT “turn” the ignition key in an attempt to start the engine. Doing so may cause it to break.

### Fuel Shut-off Valve (optional equipment)

On models so equipped, the fuel shut-off valve, located under fuel tank, controls fuel-flow from the gas tank. See Figure 11.

### Throttle Control

The throttle control is located on the engine. It regulates the speed of the engine. See Figure 11.

## SECTION 4: OPERATING YOUR SNOW THROWER

### Before Starting



**WARNING:** Read, understand, and follow all instructions and warnings on the machine and in this manual before operating.

- The spark plug wire was disconnected for safety. Attach spark plug wire to spark plug before starting.



**WARNING:** Use extreme care when handling gasoline. Gasoline is extremely flammable and the vapors are explosive. Never fuel machine indoor or while the engine is hot or running. Extinguish cigarettes, cigars, pipes and other sources of ignition.

### Gas And Oil Fill-up

- At the factory, a plastic **cup** is inserted inside the fuel tank’s fill opening (beneath the fuel cap) to prevent debris from entering the fuel tank during assembly. Remove and discard this cup before filling up the tank.

### Starting Engine



**IMPORTANT:** Prior to operating your snow thrower, read, understand and follow ALL instructions to perform adjustments found under the heading **Auger Control Test** on page 12 of this manual.

- Attach spark plug wire to spark plug. Make certain the metal loop on end of the spark plug wire (inside the boot) is fastened securely over the metal tip on the spark plug. See Figure 12.

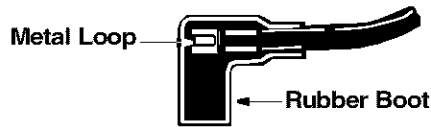

Figure 12

- Make certain the fuel shut-off valve, if so equipped, is in the OPEN (vertical) position.
- Make certain the auger and traction controls are in the disengaged (released) position.
- Move throttle control up to FAST position. Insert ignition key into slot. Be certain it snaps into place. Do not turn key. See Figure 11.

**NOTE:** Engine will not start unless ignition key is inserted into ignition slot in carburetor cover. Do not turn ignition key.

#### Recoil Starter:

- Rotate choke knob to FULL choke position (cold engine start).
- If engine is warm, place choke in OFF position instead of FULL.
- Push primer button three or four times for cold engine start.
- If engine is warm, push primer button once only.

**NOTE:** Always cover vent hole in primer button when pushing. Additional priming may be necessary for first start if temperature is below 15 degrees Fahrenheit.

- Grasp starter handle and pull rope out slowly, until it pulls slightly harder. Let rope rewind slowly.
- Pull starter handle rapidly. Do not allow handle to snap back. Allow it to rewind slowly while keeping a firm hold on the starter handle.
- Repeat step above until engine starts.
- As engine warms up and begins to operate evenly, rotate choke knob slowly to OFF position. If engine falters, return to FULL choke, then slowly move to OFF position.

#### Electric Starter

The electric starter is equipped with a grounded three-wire power cord and plug, and is designed to operate on 120 volt AC household current.



**WARNING:** The electric starter must be used with a properly grounded three-prong receptacle at all times to avoid possibility of electric shock. Follow all instructions carefully to operate the electric starter.

- Determine that your house wiring is a three-wire grounded system. Ask a licensed electrician if you are not certain.

- **If your home wiring system is not a three-wire grounded system**, do not use this electric starter under any conditions.
- **If your home electrical system is grounded**, but a three-hole receptacle is not available, one should be installed by a licensed electrician before using the electric starter.
- **If you have a grounded three-prong receptacle**, proceed as follows.
  - Rotate choke knob to OFF position.
  - Connect power cord to switch box on engine. Plug the other end of power cord into a three-prong 120-volt, grounded, AC receptacle.
  - Push starter button to crank engine. As you crank the engine, move choke knob to FULL choke position.
  - When engine starts, release starter button, and move choke gradually to OFF. If engine falters, move choke immediately to FULL and then gradually to OFF.
  - When disconnecting the power cord, always unplug from the three-prong receptacle first, and then from the snow thrower.

#### To Stop Engine

- To stop engine, remove the ignition key. Do not turn key. Disconnect the spark plug wire from the spark plug to prevent accidental starting while equipment is unattended.

#### To prevent starter freeze-up:

- Run engine for a few minutes before stopping to help dry off any moisture on the engine.
- **Electric Starter:** Connect power cord to switch box on engine, then to 120 volt AC receptacle. With the engine running, push starter button and spin the starter for several seconds. The unusual sound made by spinning the starter will not harm engine or starter. Disconnect the power cord from receptacle first, and then from switch box.
- **Recoil Starter:** With engine running, pull starter rope with a rapid, continuous full arm stroke three or four times. Pulling the starter rope will produce a loud clattering sound, which is not harmful to the engine or starter.
- Wipe all snow and moisture from the carburetor cover in the area of the control levers. Also, move control levers back and forth several times. Leave throttle control lever in the STOP or OFF position. Leave choke control in the FULL choke position.
- Remove ignition key and disconnect spark plug wire. Do not turn key.

**IMPORTANT:** Do not lose the ignition key. Keep it in a safe place. Engine will not start without the ignition key.

## To Engage Drive

- With the engine running near top speed, move shift lever into one of the five FORWARD positions or two REVERSE positions. Select a speed appropriate for the snow conditions that exist. Use the slower speeds until you are familiar with the operation of the snow thrower.
- Squeeze the auger control and the augers will turn. Release it and the augers will stop.
- Squeeze traction control and the snow thrower will move. Release it and unit will stop. Never move shift lever without releasing traction control.

## To Engage Augers

- To engage augers and start throwing snow, squeeze the auger control against the left handle. Release to stop the augers.

### Auger Control Test

**IMPORTANT:** Perform the following test before operating the snow thrower for the first time and at the start of each winter season.

Check the adjustment of the auger control as follows:

- When the auger control is released and in the disengaged “up” position, the cable should have very little slack, but should NOT be tight.



**WARNING:** Do not over-tighten the cable. Over-tightening may prevent the auger from disengaging and compromise the safety of the snow thrower.

- In a well-ventilated area, start the snow thrower engine as instructed earlier in this section under the heading **Starting Engine**. Make sure the throttle is set in the FAST position.
- While standing in the operator’s position (behind the snow thrower) engage the auger.
- Allow the auger to remain engaged for approximately ten (10) seconds before releasing the auger control. Repeat this several times.
- With the engine running in the FAST position and the auger control lever in the disengaged “up” position, walk to the front of the machine.
- Confirm that the auger has completely stopped rotating and shows NO signs of motion.

**IMPORTANT:** If the auger shows ANY signs of rotating, immediately return to the operator’s position and shut off the engine. Wait for all moving parts to stop before readjusting the auger control cable.

- To readjust the control cable, loosen the hex jam nut on the auger control cable “Z” fitting.
- Rotate the coupling end of the cable counterclockwise to provide more slack.
- Retighten the hex jam nut. See Figure 13.

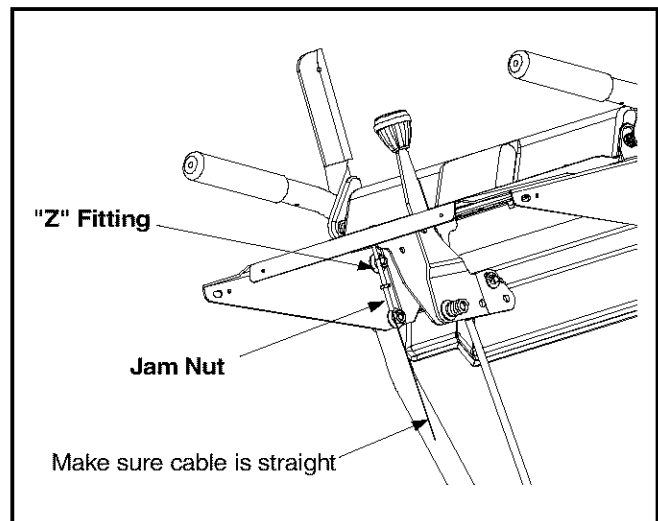

**Figure 13**

- Repeat Auger Control Test to verify proper adjustment has been achieved.

## Chute Clean-out Tool

The chute clean-out tool is conveniently fastened to the rear of the auger housing with a mounting clip (Refer to Figure 11). If the discharge chute becomes clogged during operation, proceed as follows to safely clean the chute and chute opening:

1. Release both the Auger Control Lever and the Traction/Auger Control Lock Lever.
2. Stop the engine by removing the ignition key.
3. Remove the clean-out tool from the clip which secures it to the rear of the auger housing.
4. Use the shovel-shaped end of the clean-out tool to remove any snow and ice in the discharge chute.



**WARNING:** Never use your hand to clear a clogged discharge chute. Shut off engine and remain behind handles until all moving parts have stopped before unblocking.

5. Refasten the clean-out tool to the mounting clip on the rear of the auger housing, re-start the engine.
6. While standing in the operator’s position (behind the snow thrower), engage the auger clutch lever for a few seconds to clear any remaining snow or ice from the discharge chute before continuing to clear snow.

## Tire Chains (Optional Equipment)

Tire chains may be used whenever extra traction is needed. Contact Customer Support as instructed on page 2 for information regarding price and availability.

Snow Thrower Model	Tire Chain Kit
E600E, S610E	OEM-390-139
E640F, E660F & E6C0F	OEM-390-991
E660G	OEM-390-665

## Drift Cutters (Optional Equipment)

Drift cutters should be used when operating the snow thrower in heavy drift conditions.

On models so equipped, drift cutters are assembled to the auger housing inverted. Remove the carriage bolts by unthreading the hex nuts which secure them, and reinstall the drift cutters in their proper position before operating the snow thrower. See Figure 14.

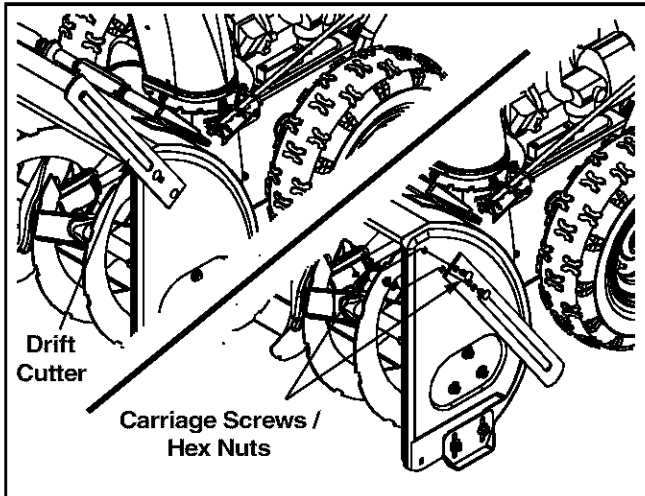

Figure 14

If your unit is not equipped with drift cutters, contact Customer Support as instructed on page 2 for information regarding price and availability.

Snow Thrower Model	Drift Cutter Kit
All models	OEM-390-679

## Operating Tips

**NOTE:** Allow the engine to warm up for a few minutes as the engine will not develop full power until it reaches operating temperature.



**WARNING:** The muffler, engine and their surrounding areas become hot and can cause a burn. Do not touch.

- Discharge snow downwind whenever possible. Slightly overlap each previous path.
- Set the skid shoes 1/4" below the scraper bar for normal usage. The skid shoes may be adjusted upward for hard-packed snow. Adjust downward when using on gravel or crushed rock.
- Avoid possible starter freeze-up. Clean the snow thrower thoroughly after each use.

## SECTION 5: MAKING ADJUSTMENTS



**WARNING:** NEVER attempt to make any adjustments while the engine is running, except where specified in the operator's manual.

### Tire Pressure (Pneumatic Tires)

- The tires are over-inflated for shipping purposes. Before operating, check tire pressure and reduce, if necessary, to between 15 psi and 20 psi.

**NOTE:** If the tire pressure is not equal in both tires, the unit may pull to one side or the other.

### Traction Control and Shift Lever

- To check the adjustment of the traction control and shift lever, proceed as follows:
- With the engine off, move the shift lever all the way forward to sixth (6) position. With the traction control released, push the snow thrower forward. The unit should move forward freely. Then engage the traction control grip. Wheels should stop turning.
- Now release the traction control grip, and push the unit again.
- Move the shift lever back to the fast reverse position, then all the way forward again. There

should be no resistance in the shift lever, and wheels should keep turning.

- If you feel resistance when moving the shift lever or the wheels stop when they should not, loosen the jam nut on the traction control cable and unthread the cable one turn.
- If the wheels do not stop when you engage the traction control grip, loosen the jam nut on the traction control cable and thread the cable in one turn. Recheck the adjustment and repeat as necessary. Tighten the jam nut to secure the cable when correct adjustment is reached.



**WARNING:** Drain the gasoline out of snow thrower engine, place a piece of plastic film under the gas cap to avoid spillage before beginning the job.

To test further for correct adjustment, if necessary, proceed as follows:

- Tip the snow thrower forward, allowing it to rest on the auger housing.
- Remove the frame cover underneath the snow thrower by removing six self-tapping screws.
- With the traction control released, there must be clearance between the friction wheel and the drive plate in all positions of the shift lever.

- With traction control engaged, the friction wheel must contact the drive plate. See Figure 15.

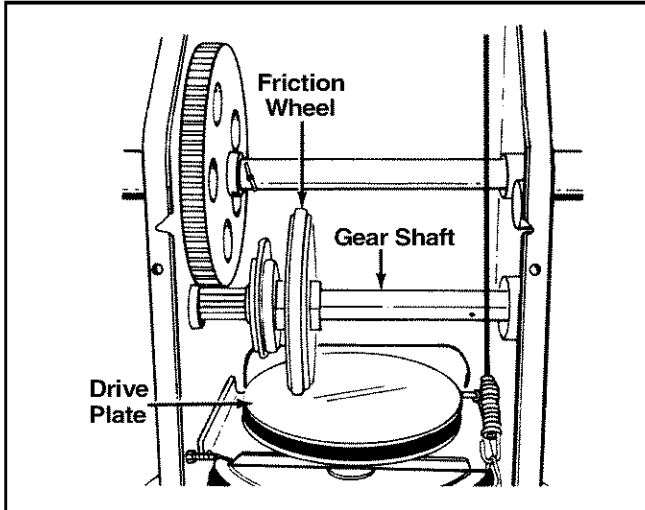

Figure 15

If adjustment is necessary:

- Loosen the jam nut on the traction drive cable and thread the cable in or out as necessary.
- Retighten the jam nut to secure the cable when correct adjustment is reached.
- Reassemble the frame cover.

*NOTE: If you placed plastic film under the gas cap, be certain to remove it before operating the snow thrower.*

## Shift Rod

To adjust the shift rod, proceed as follows.

- Remove the hairpin clip and flat washer from the shift handle under the handle panel.
- Place shift lever in sixth (6) position or the fastest forward speed.
- Push shift arm assembly down as far as it will go.
- Rotate the ferrule up or down on the shift rod as necessary until the ferrule lines up with the upper hole in the shift lever. See Figure 16.

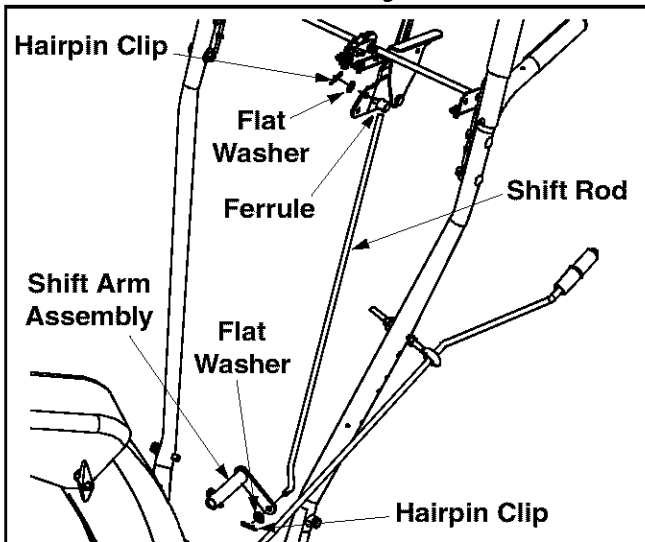

Figure 16

- Insert ferrule into the upper hole in shift lever.
- Reinstall the hairpin clip and the washer.

**IMPORTANT:** Check for correct adjustment of the shift lever as instructed on page 13, before operating the snow thrower.

## Chute Assembly

The distance snow is thrown can be adjusted by changing the angle of the chute assembly. To do so, stop the engine by removing the ignition key and loosen the plastic wing knobs found on either side of the discharge chute. Pivot the chute upward or downward before re-tightening the wing knobs.

## Skid Shoes

The space between the shave plate and the ground can be adjusted. For close snow removal, place skid shoes in the low position. Use middle or high position when area to be cleared is uneven.

- Adjust skid shoes by loosening the four hex nuts and carriage bolts and moving skid shoes to desired position. Make certain the entire bottom surface of skid shoe is against the ground to avoid uneven wear on the skid shoes. Retighten nuts and bolts securely.

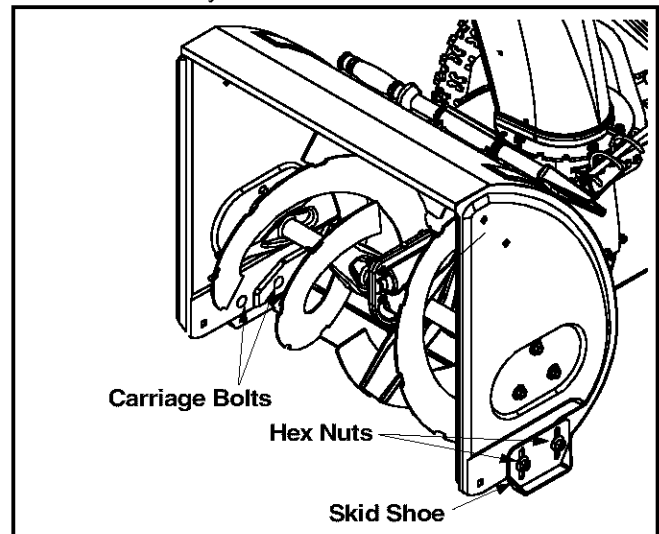

Figure 17



**WARNING:** Do not operate this snow thrower on gravel as loose gravel can be easily picked up and thrown by the auger causing injury to the operator and/or damage to the snow thrower.

## Auger Control

Refer to **Auger Control Test** on page 12 to adjust the auger control.

## Drive Wheels

The wheels may be adjusted for two different methods of operation. The adjustment is made by placing the click pins in one of two different holes on the right side of the unit. See Figure 18.

**One Wheel Driving:** Insert the click pin only through the outside hole of the axle (not the rim) on the right side of the snow thrower. This position gives power drive to the left wheel only, making the unit easier to maneuver.

**Both Wheels Driving:** Insert the click pin through the hole in the hub of the rim and the inside hole on the snow thrower's right axle. This position is good for heavy snow as there is power drive in both wheels.

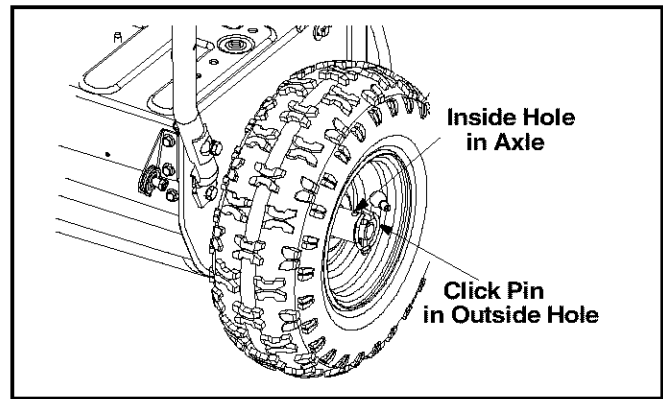

Figure 18

**IMPORTANT:** Never operate the snow thrower with the click pin inserted through both the rim and the outside hole in the axle. Doing so can result in serious damage to the drive system.

## SECTION 6: MAINTAINING YOUR SNOW THROWER



**WARNING:** Before servicing, repairing or inspecting, disengage all clutch levers and stop engine. Wait until all moving parts have come to a complete stop. Disconnect spark plug wire and ground it against the engine to prevent unintended starting.

### Lubrication

#### Engine

- Refer to the engine manual for maintenance procedures and instructions.



**WARNING:** When following instructions in the engine manual for draining oil, be sure to protect frame to avoid oil dripping onto transmission parts.

#### Gear Shaft

- Lubricate the gear shaft with a good all-weather multi-purpose light grease at least once a season or after every 25 hours of operation.

#### Gear Case

- The auger gearbox has been filled with grease at the factory. If disassembled for repairs, lubricate with 1-1/2 ounces of grease, part no. 737-0168.

**IMPORTANT:** Do not overfill the gear case. Damage to the seals could result. Be sure the vent plug is free of grease in order to relieve pressure.

#### Auger Shaft

- At least once a season, remove shear bolts on auger shaft. Oil or spray lubricant inside shaft. Also lubricate the auger bearings at least once a season. See Figure 19.

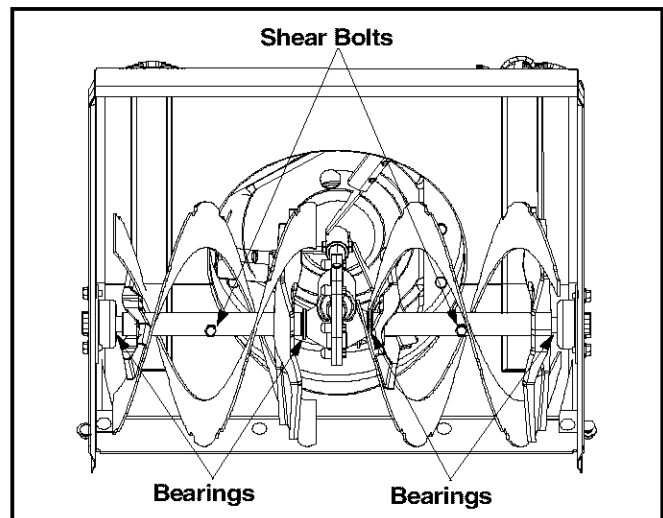

Figure 19

#### Chute Directional Control

- The worm gear on the chute directional control should be greased with multipurpose automotive grease.

**IMPORTANT:** Keep all grease and oil off friction wheel and drive plate.

#### Drive and Shifting Mechanism

- Remove rear cover. Oil any chains, sprockets, gears, bearings, shafts, and shifting mechanism at least once a season. Use engine oil or a spray lubricant. Avoid getting oil on rubber friction wheel and aluminum drive plate.

## Wheels

- Oil or spray lubricant into bearings at least once a season. Pull the klick pins and remove wheels, clean and coat axles with a multipurpose automotive grease. See Figure 20.

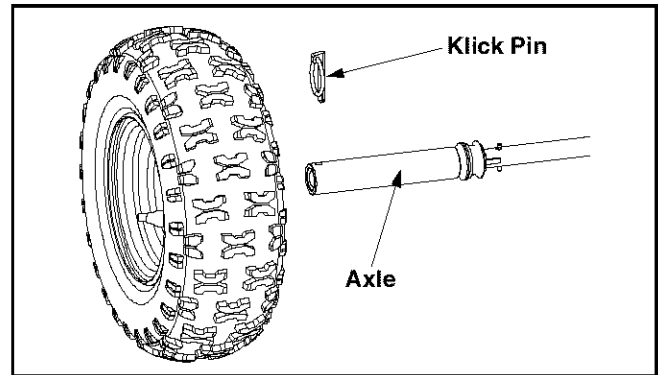

Figure 20

## SECTION 7: SERVICE



**WARNING:** Before servicing, repairing, or inspecting, disengage all clutch levers and stop engine. Wait until all moving parts have come to a complete stop. Disconnect spark plug wire and ground it against the engine to prevent unintended starting.

## Augers

The augers are secured to the spiral shaft with two shear bolts and hex lock nuts. If the snow thrower hits a foreign object or ice jam, hex bolts will shear.

- If the augers will not turn, check to see if the bolts have sheared. Two replacement shear bolts and hex lock nuts have been provided in the snow thrower's hardware pack. For future use, order part number 710-0890A (shear bolt 5/16-18 x 1.5") and 712-0429 (hex lock nut 5/16-18).

## Shave Plate and Skid Shoes

The shave plate and skid shoes on the bottom of the snow thrower are subject to wear. They should be checked periodically and replaced when necessary.

- To remove skid shoes, remove the four carriage bolts, bell washers and hex nuts which attach them to the snow thrower. Reassemble new skid shoes with the four carriage bolts, bell washers (cupped side goes against skid shoes) and hex nuts. Make certain the skid shoes are adjusted to be level.
- To remove shave plate, remove carriage bolts, bell washers and hex nuts which attach it to the snow thrower housing.
- Reassemble new shave plate, making sure heads of the carriage bolts are to the inside of the housing. Tighten securely.

## Belt Replacement



**WARNING:** Disconnect the spark plug wire from the spark plug and ground.

### Auger Belts

**NOTE:** It is necessary to remove both auger belts in order to change either one (models S610E & E600E have only one auger belt). If changing just one belt, be certain to check the condition of the other belt.

- Remove the plastic belt cover on the front of the engine by removing the two self-tapping screws. See Figure 21.
- Drain the gasoline from the snow thrower, or place a piece of plastic under the gas cap.
- Tip the snow thrower up and forward so that it rests on the housing.
- Remove six self-tapping screws from the frame cover underneath the snow thrower. See Figure 21 for the location of the hardware.

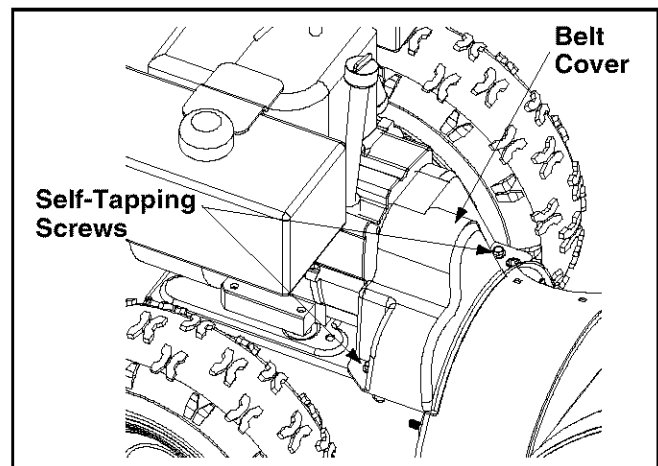

Figure 21



- Roll the front and rear auger belts off the engine pulley. See Figure 22.

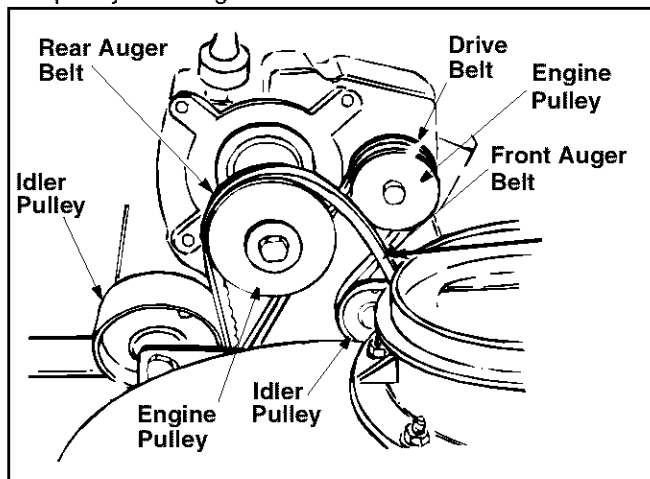

Figure 22

- Unhook the idler spring from the hex bolt on the auger housing. See Figure 23.
- Back out the stop bolt to allow the belts to slip between the bolt and auger pulley. See Figure 24.

**NOTE:** It may be necessary to loosen the six hex nuts that fasten the frame to the auger housing.

- Lift the rear auger belt from the auger pulley, and slip belt between the support bracket and the auger pulley. See Figure 23. Repeat this step for front auger belt (except models 600/610E).
- Replace both auger drive belts by following instructions in reverse order.

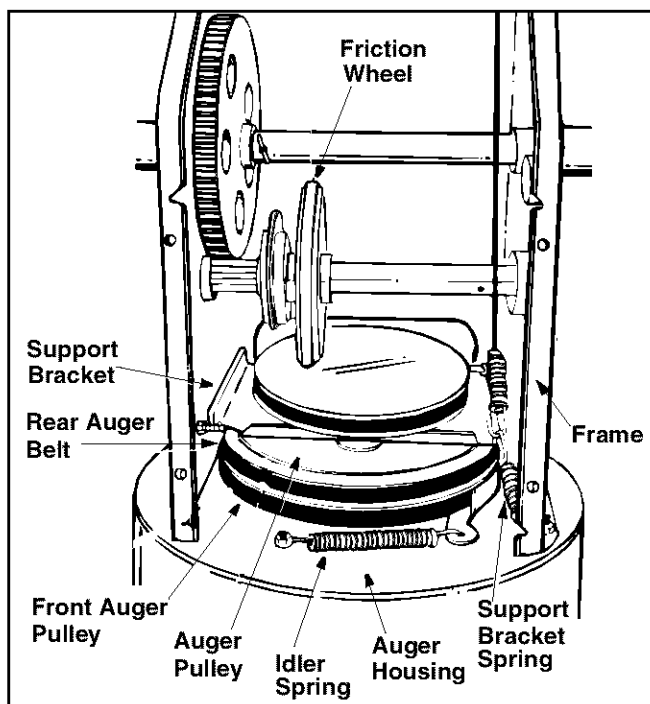

Figure 23

### Drive Belt

- Follow steps 1 through 4 of previous instructions.
- Pull idler pulley up, and lift belt off engine pulley and friction wheel disc. See Figure 22.
- Back out the stop bolt until the support bracket rests on the auger pulley. See Figure 24.
- Slip belt between friction wheel and friction wheel disc. Remove and replace belt. Reassemble following the instructions in reverse order.

**NOTE:** The support bracket must rest on the stop bolt after the new belt has been assembled. See Figure 25.

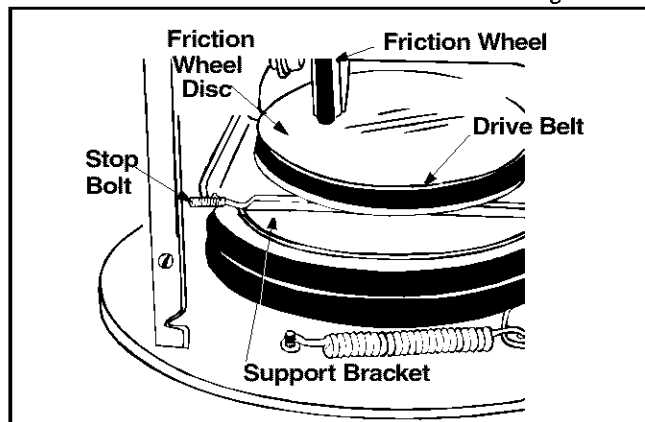

Figure 24

### Changing Friction Wheel Rubber

The rubber on the friction wheel is subject to wear and should be checked after 25 hours of operation, and periodically thereafter. Replace the friction wheel rubber if any signs of wear or cracking are found.

- Drain the gasoline from the snow thrower, or place a piece of plastic under the gas cap.
- Tip the snow thrower up and forward, so that it rests on the housing. See Figure 25.

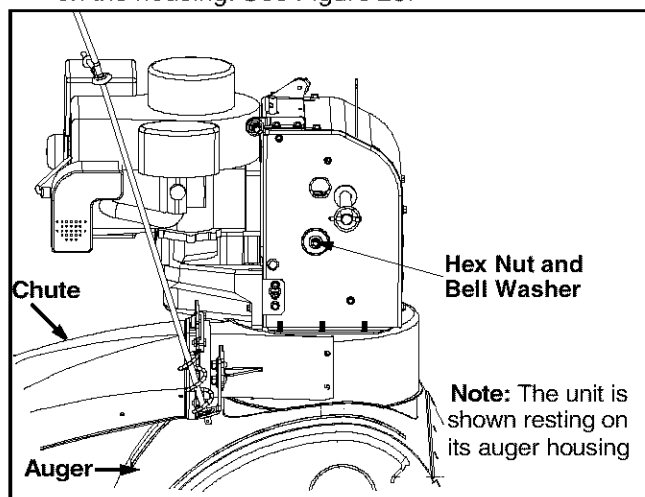
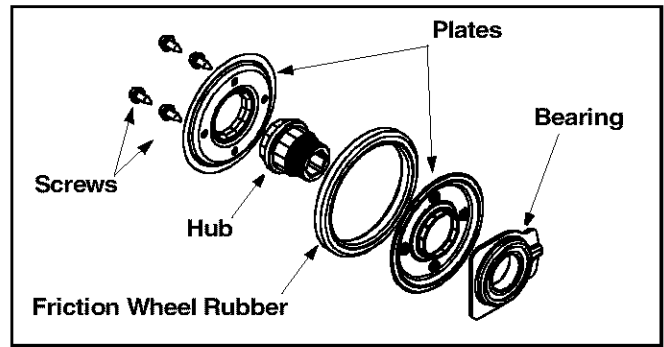

Figure 25

- Remove the six self-tapping screws from the frame cover underneath the snow thrower.
- Remove the click pins which secure the wheels, and remove the wheels from the axle.

- Using a wrench to hold the shaft, loosen, but do not completely remove, the hex nut and bell washer on left end of gear shaft. See Figure 25.
- Lightly tap the hex nut to dislodge the ball bearing from the right side of frame. Remove the hex nut and bell washer from left end of shaft.
- Slide the gear shaft to the right and slide the friction wheel assembly from the shaft.
- Remove the four screws from the friction wheel assembly. Remove the friction wheel rubber from between the plates. See Figure 26.
- Reassemble new friction wheel rubber to the friction wheel assembly, tightening the four screws in rotation and with equal force.



**Figure 26**

- Position the friction wheel assembly up onto the pin of the shift rod assembly, and slide the shaft through the assembly. Reassemble the wheels and the frame cover.

## SECTION 8: OFF-SEASON STORAGE



**WARNING:** Never store engine with fuel in tank indoors or in enclosed, poorly ventilated areas where fuel fumes may reach an open flame, spark or pilot light as on a furnace, water heater, clothes dryer, or other gas appliance.

- If unit is to be stored over 30 days, prepare the engine for storage following instructions in the engine manual.

- Remove all dirt from exterior of engine and equipment.
- Follow lubrication recommendations on page 15.

**NOTE:** *When storing any type of power equipment in an poorly ventilated or metal storage shed, care should be taken to rustproof the equipment, especially springs, cables and all moving parts.*

## SECTION 9: TROUBLE SHOOTING GUIDE

Trouble	Possible Cause(s)	Corrective Action
Engine fails to start	Fuel tank empty, or stale fuel.  Blocked fuel line. Choke not in ON position Faulty spark plug. Key not in switch on engine. Spark plug wire disconnected. Primer button not depressed. Fuel shut-off valve closed (if so equipped).	Fill tank with clean, fresh gasoline. Fuel may not last over thirty days unless a fuel stabilizer is used. Clean fuel line. Move switch to ON position Clean, adjust gap or replace. Insert key. Connect spark plug wire.  Refer to the engine manual packed with your unit. Open fuel shut-off valve.
Engine runs erratic	Unit running on CHOKE. Blocked fuel line or stale fuel.  Water or dirt in fuel system. Carburetor out of adjustment.	Move choke lever to OFF position. Clean fuel line; fill tank with clean fresh gasoline. Fuel may not last over thirty days unless a fuel stabilizer is used. Drain fuel tank. Refill with fresh fuel. Refer to the engine manual packed with your unit or have carburetor adjusted by an authorized service dealer.
Loss of power	Spark plug wire loose. Gas cap vent hole plugged. Exhaust port plugged.	Connect and tighten spark plug wire. Remove ice and snow from cap. Be certain vent hole is clear. Clean-see Maintenance section of engine manual.
Engine overheats	Carburetor not adjusted properly. Incorrect fuel mixture.	Refer to the engine manual packed with your unit or have carburetor adjusted by an authorized service dealer. Drain fuel tank. Refill with proper fuel mixture.
Excessive vibration	Loose parts or damaged auger.	Stop engine immediately and disconnect spark plug wire. Tighten all bolts and nuts. Make all necessary repairs. If vibration continues, have unit serviced by an authorized service dealer.
Unit fails to propel itself	Incorrect adjustment of drive cable. Drive belt loose or damaged.	Adjust drive cable. Refer to Adjustment section of this manual. Replace drive belt. Refer to Belt Replacement on page 16.
Unit fails to discharge snow	Discharge chute clogged.  Foreign object lodged in auger. Incorrect adjustment of drive cable.  Drive belt loose or damaged. Shear bolt(s) sheared	Stop engine immediately and disconnect spark plug wire. Clean discharge chute and inside of auger housing. Stop engine immediately and disconnect spark plug wire. Remove object from auger. Adjust drive cable. Refer to Adjustment section of this manual.  Replace drive belt. Refer to Belt Replacement on page 16. Replace shear bolt(s)

**NOTE:** For repairs beyond the minor adjustments listed above, contact your nearest authorized service dealer or call 1-800-800-7310 for the Customer Support Center. Refer to separate engine manual packed with your snow thrower for more engine related information.

# SECTION 10: PARTS LIST

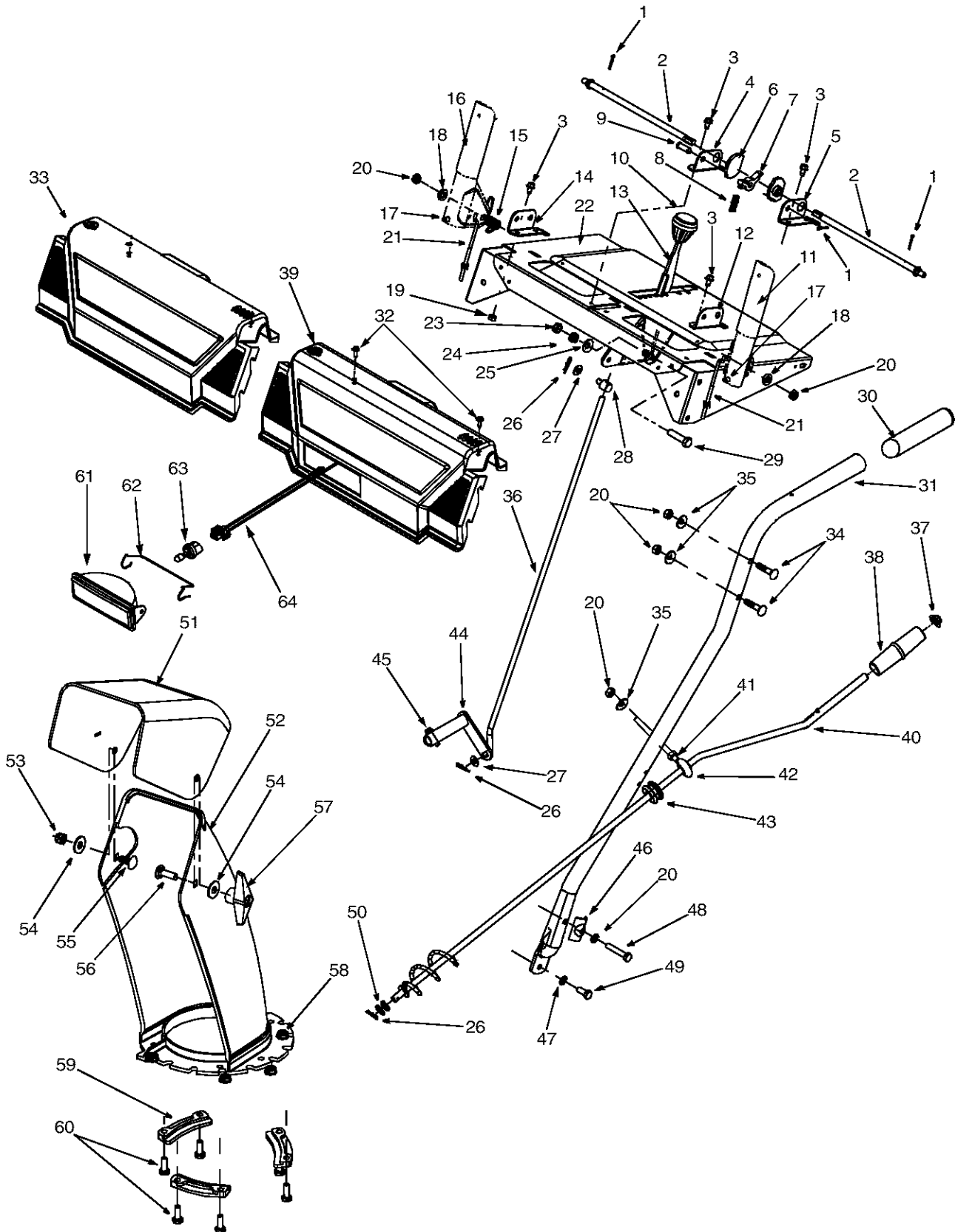

## Models E600E, S610E, E640F, E660F, E6C0F & E660G

REF. NO.	PART NO.	DESCRIPTION	REF. NO.	PART NO.	DESCRIPTION
1	714-0507	Cotter Pin	32	710-1003	Hex Washer Screw
2	747-0877	Rod	33	731-1391	Handle Panel (w/o lamp cut-out)
3	710-0599	Hex Washer Screw 1/4-20 x .5	34	710-0262	Carriage Bolt 5/16-18 x 1.50
4	784-5680	Handle Support Bracket - RH	35	736-0242	Bell Washer .340 ID x .872 OD
5	784-5679	Handle Support Bracket - LH	36	747-0798A	Shift Rod
6	748-0362	Cam Lock Handle	37	726-0100	Push Cap
7	748-0363	Handle Lock Pawl	38	720-0201A	Chute Knob
8	732-0145	Compression Spring	39	731-1392	Panel (w/ lamp cut-out)
9	711-0653	Clevis Pin	40	705-5204A	Chute Crank
10	720-0232	Knob	42	747-0697	Chute Crank Eyebolt
11	684-0037B	Handle Assy - LH	43	735-0234	Rubber Grommet
12	784-5681	Handle Support Bracket - LH	44	684-0008A	Shift Arm Assembly
13	784-5619A	Shift Handle	45	710-0788	Hex Washer Screw 1/4-20 x 1.0
14	784-5682	Handle Support Bracket - RH	46	784-5599	Handle Tab
15	732-0746	Torsion Spring	47	736-0119	Lock Washer 5/16
16	684-0036A	Handle Assy - RH	48	710-04039	Hex Cap Screw 5/16-18 x 2
17	735-0199A	Rubber Bumper	49	710-3008	Hex Cap Screw 5/16-18 x .75
18	736-0509	Washer	50	736-0185	Flat Washer
19	712-0271	Hex Nut 1/4-20 †	51	731-0921	Upper Chute
20	712-3068	Hex Nut 5/16-18	52	731-1300B	Lower Chute
21	746-0778	Cable	53	712-3068	Hex Lock Nut 5/16-18
22	684-0103	Panel	54	736-0159	5/16 Washer
23	712-0116	Jam Lock Nut 3/8-24	55	710-0451	Carriage Bolt 5/16-18 x .75
24	732-0193	Compression Spring	56	710-04071	Carriage Screw 5/16-18 x 1.0
25	736-0105	Bell Washer	57	720-0284	Knob
26	714-0104	Cotter Pin	58	712-3027	Hex Lock Nut 1/4-20
27	736-0275	Flat Washer 5/16	59	731-0851A	Flange Keeper
28	711-0677	Ferrule	60	710-3015	Hex Cap Screw 1/4-20 x .75
29	710-0459A	Hex Cap Screw 3/8-24 x 1.50	61	725-1672	Lens Housing Assembly
30	720-0274	Grip	62	747-1136	Headlight Retaining Wire
31	749-0911C	Handle -LH	63	725-1658	Halogen Light
	749-0910C	Handle -RH (not shown)	64	629-0059	Light Harness

† Used with ground wire; found on model's with an in-dash light only.

**NOTE:** Snow thrower features vary by model. NOT all parts listed above and pictured on the previous page are standard equipment.

# Models E600E, S610E, E640F, E660F, E6C0F & E660G

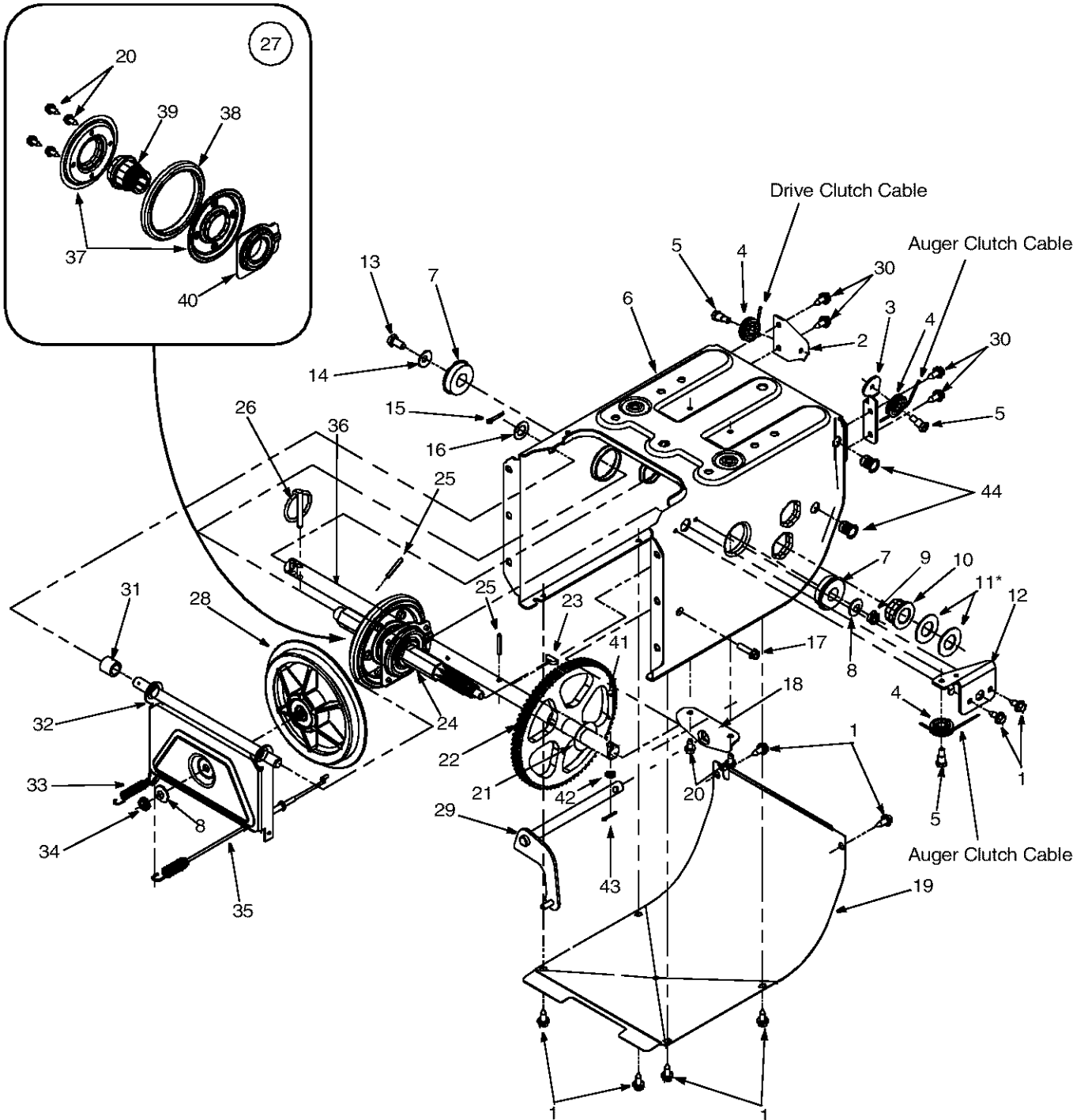

# Models E600E, S610E, E640F, E660F, E6C0F & E660G

REF. NO.	PART NO.	DESCRIPTION	REF. NO.	PART NO.	DESCRIPTION
1	710-1652	Self-tapping Screw, 1/4-20 x .625	24	717-1444	7-Tooth Shaft
2	784-5688	Drive Cable Guide Bracket	25	715-0249	Roll Pin
3	784-5687A	Auger Clutch Cable Bracket	26	714-0143	Klik Pin
4	756-0625	Cable Roller	27	684-0042B	Friction Wheel Assembly
5	738-0924	Hex Screw 1/4-28	28	656-0012A	Friction Disc Wheel
6	784-5630B	Frame Assembly	29	684-0013B	Wheel Shift Rod Assembly
7	741-0563	Ball Bearing	30	710-0599	Self-tapping Screw, 1/4-20 x .5
8	736-0105	Bell Washer	31	748-0190	Spacer
9	712-0116	Lock Jam Nut	32	684-0021	Friction Wheel Bracket Assembly
10	741-04026	Hex Flange Bearing	33	732-0264	Extension Spring
11	736-0188	Flat Washer†	34	712-0711	Jam Nut 3/8-24
12	784-5689A	Front Support Guide Bracket	35	746-0898B	Drive Cable
13	710-0538	Lock Hex Screw	36	738-0869	Axle 13" Wheels
14	736-0242	Bell Washer .340 ID x .872 OD		738-0830	Axle 16" Wheels
15	714-0474	Cotter Pin	37	784-5617A	Friction Plate
16	736-0160	Flat Washer .536 ID x .930 OD	38	735-0243B	Friction Wheel Rubber
17	710-0809	Self-tapping Screw, 1/4-20 x 1.25	39	718-0301A	Friction Wheel Hub
18	784-5590	Frame Shift Bracket	40	618-0063A	Friction Wheel Bearing
19	784-5638	Frame Cover	41	711-1364	Clevis Pin, 1/4 x 1.3725
20	710-1652	Hex Washer TT Screw 1/4-20	42	736-0142	Flat Washer, .281 x .5 x .063
21	736-0351	Flat Washer .760 ID x .50 OD	43	714-0507	Cotter Pin, .75
22	717-1445	Gear	44	712-0703A	Insert Nut, 5/16-18
23	714-0126	Key			

† Use more than one washer on either side, only if necessary to reduce axle-play.

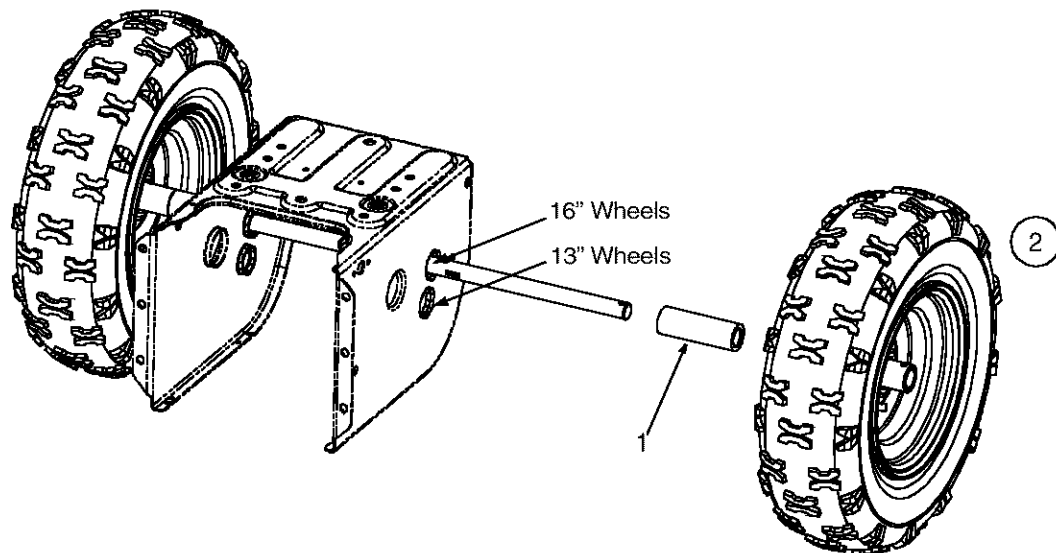

WHEEL CHART							
MODEL NUMBER	WHEEL SIZE	REF. NO. 1 SPACER	REF. NO. 2 WHEEL ASS'Y*	TIRE ONLY	AIR VALVE	RIM ONLY	SLEEVE BEARING (2)
E600E	13 x 5	741-04044	734-1714A	734-1527	734-0255	734-1713A	741-0401
S610E	13 x 5	741-04044	734-1714A	734-1527	734-0255	734-1713A	741-0401
E640F	16 x 4.8	741-04043	734-1709A	734-1530	734-0255	734-1708A	741-0401
E660F	16 x 4.8	741-04043	734-1709A	734-1530	734-0255	734-1708A	741-0401
E6C0F	16 x 4.8	741-04043	734-1709A	734-1530	734-0255	734-1708A	741-0401
E660G	16 x 6.5	741-04043	734-1712A	734-1525	734-0255	734-1711A	741-0401

\* A wheel assembly includes one tire, one air valve, one painted rim and two sleeve bearings

# Models E600E, S610E, E640F, E660F, E6C0F & E660G

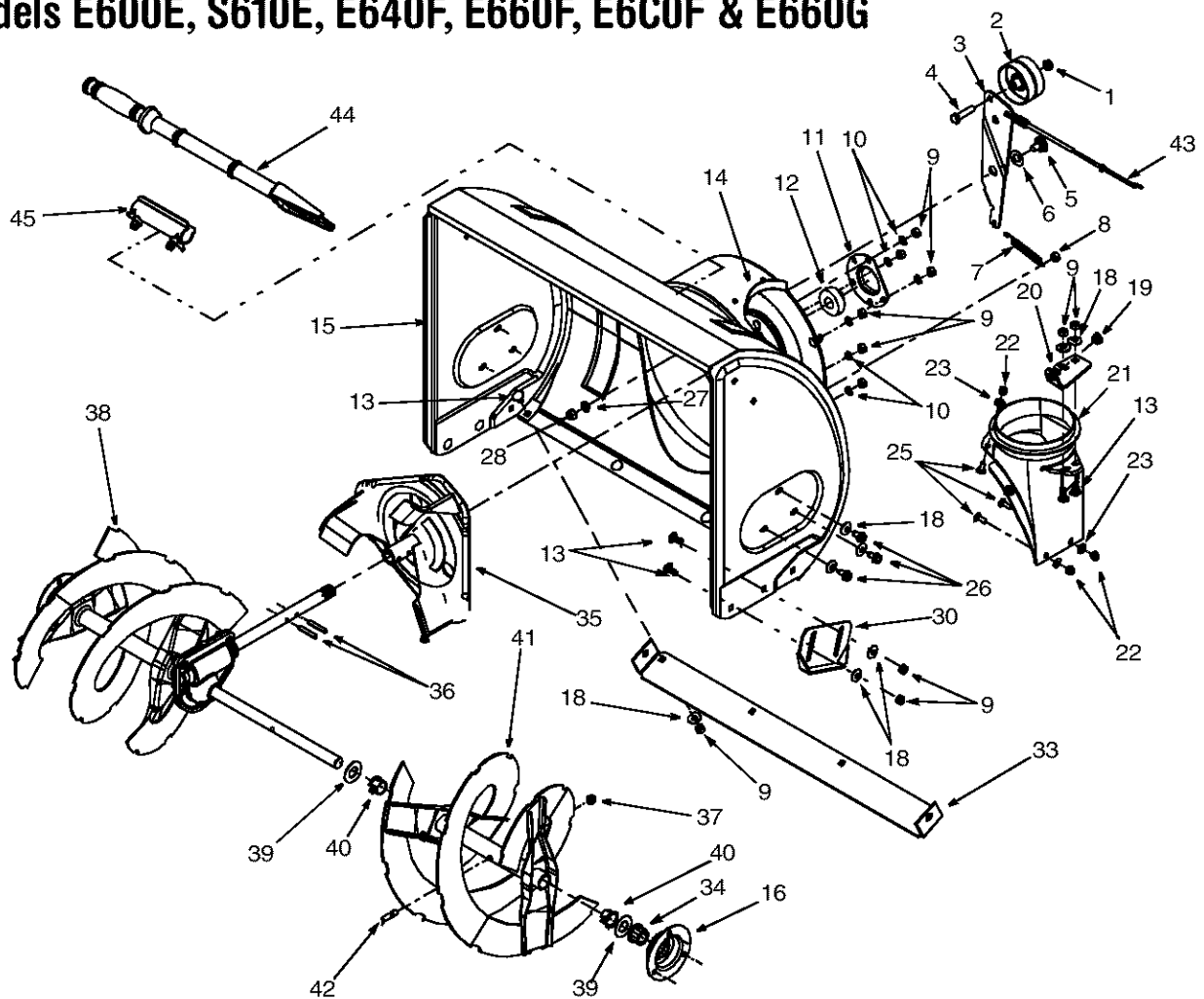

REF. NO.	PART NO.	DESCRIPTION	REF. NO.	PART NO.	DESCRIPTION
1	712-0116	Lock Jam Nut 3/8-24	26	710-0604A	Hex Washer TT Screw 5/16-18
2	756-0178	Flat Idler	27	736-0169	Lock Washer 3/8
3	784-5632B	Auger Idler Arm	28	712-0798	Hex Nut 3/8-16
4	710-0459A	Hex Cap Screw 3/8-24 x 1.50	30	784-5580	Snow Shoe
5	738-0281	Shoulder Screw	31	731-2643	Chute Clean-out Tool
6	736-0167	Flat Washer, .565 x 1.25 x .02	32	731-2635	Mount, Chute Clean-out Tool
7	732-0611	Extension Spring	33	784-5581A	24" Shave Plate
8	712-3068	Hex Nut 5/16-18		784-5579A	26" Shave Plate
9	712-3010	Hex Nut 5/16-18		784-5582A	28" Shave Plate
10	736-0119	Lock Washer 5/16	34	741-0245	Hex Flange Bearing
11	05931A	Housing	35	684-0065	Impeller Assembly
12	741-0309	Ball Bearing	36	715-0114	Pin
13	710-0451	Carriage Bolt 5/16-18 x .75	37	712-0429	Lock Nut 5/16-18
14	705-5226	Reinforcement Chute	38	605-5188A	Spiral 24" RH
15	684-0039D	24" Housing Assembly		605-5192A	Spiral 26" RH
	684-0040D	26" Housing Assembly		605-5196A	Spiral 28" RH
	684-0041D	28" Housing Assembly	39	736-0188	Flat Washer
16	784-5618	Bearing Housing	40	741-0493A	Flange Bushing
18	736-0242	Bell Washer	41	605-5189A	Spiral 24" LH
19	741-0475	Bushing		605-5193A	Spiral 26" LH
20	784-5647	Chute Crank Bracket		605-5197A	Spiral 28" LH
21	731-1379C	Chute Adapter	42	710-0890A	Shear Bolt 5/16-18 x 1.5
22	712-0324	Hex Lock Nut 1/4-20	43	746-0897	Drive Cable
23	736-0463	Flat Washer	44	731-2643	Chute Clean-out Tool
25	710-0703	Carriage Screw 1/4-20 x .75	45	731-2635	Mount, Chute Clean-out Tool



# Models E600E, S610E, E640F, E660F, E6C0F & E660G

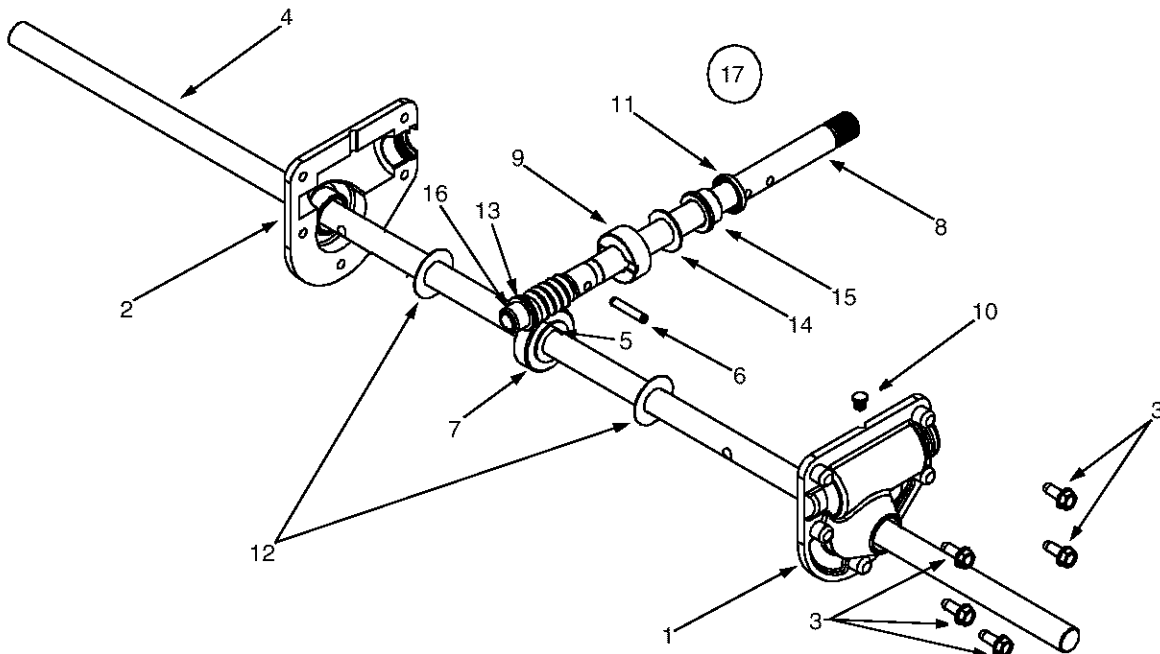

REF. NO.	PART NO.	DESCRIPTION
1	618-0123	RH Reducer Housing
2	618-0124	LH Reducer Housing
3	710-0642	Hex Screw 1/4-20 x .75
4	711-0908A	Spiral Axle 24"
	711-0909A	Spiral Axle 26"
	711-0910A	Spiral Axle 28"
5	714-0161	Key
6	715-0143	Pin-Spiral
7	717-0528	Worm Gear, 20T
8	717-0526	Worm Shaft
9	718-0186	Thrust Collar
10	721-0325	Grease Plug
11	721-0327	Grease Seal
12	736-0351	Flat Washer .76 x 1.5 x .030
13	736-0369	Flat Washer .508 x 1.0 x .020
14	736-0445	Flat Washer .76 x 1.5 x .060
15	741-0662	Flange Bearing .75 x 1.0 x .59
16	741-0663	Flange Bearing .75 x 1.0 x .925
17	618-0120A	Gearbox Ass'y. Complete 24"
	618-0121A	Gearbox Ass'y. Complete 26"
	618-0122A	Gearbox Ass'y. Complete 28"

**NOTE:** NOTE: When rebuilding a gearbox assembly, include 1.5 oz. of Alvania EP Lead-Free Grease (Part No. 737-0168)

# Models E600E & S610E

**IMPORTANT:** For a properly working machine, use Factory Approved Parts.  
**V-BELTS** are specially designed to engage and disengage safely. A substitute (non OEM) V-Belt can be dangerous by not disengaging completely.

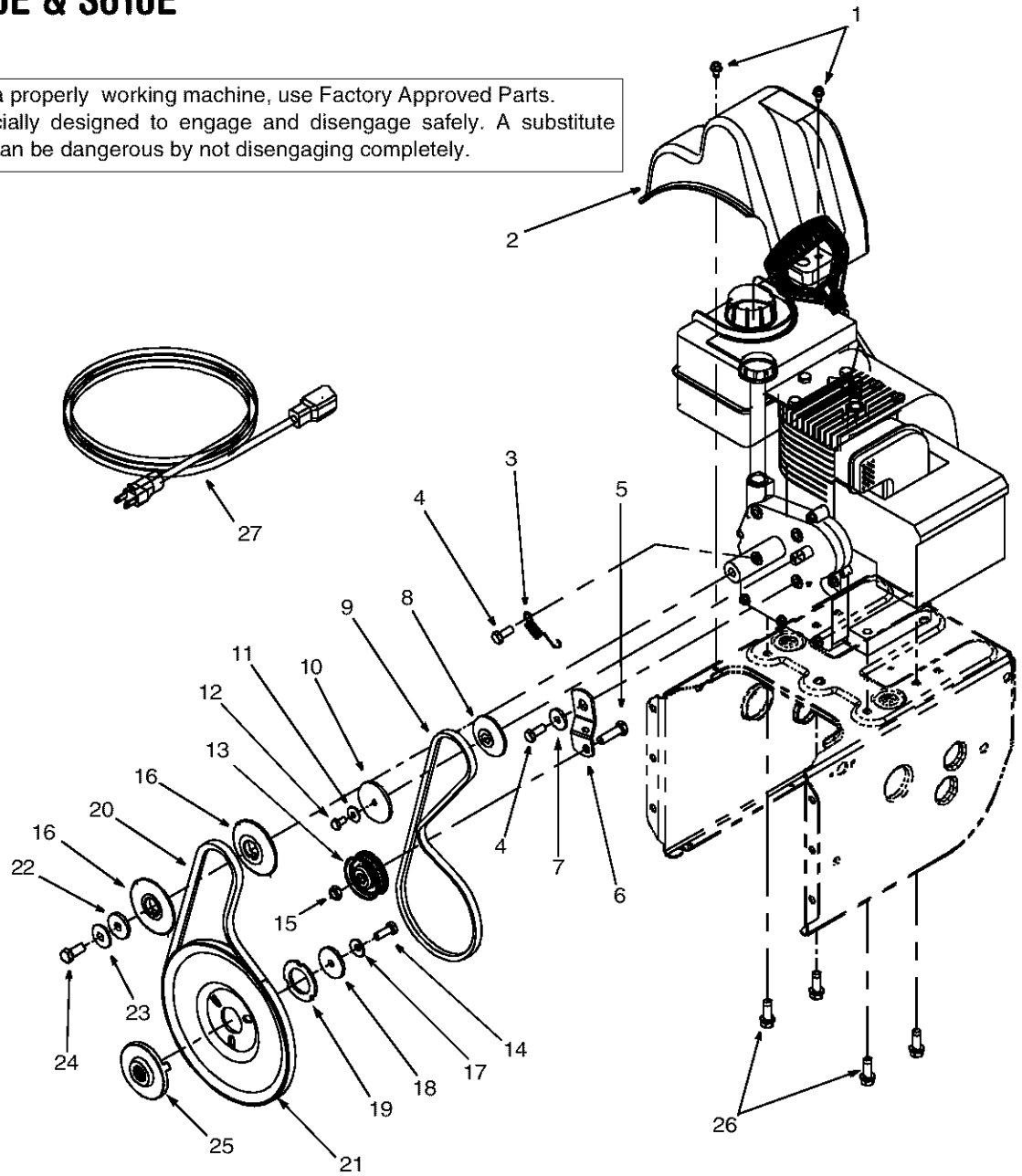

REF. NO.	PART NO.	DESCRIPTION	REF. NO.	PART NO.	DESCRIPTION
1	710-1652	Hex Washer Screw 1/4-20 x.5	15	712-0181	Lock Jam Nut 3/8-16
2	731-1324	Belt Cover	16	756-0569	Pulley Half
3	732-0339	Extension Spring	17	736-0242	Bell Washer
4	710-0627	Hex Screw 5/16-24 x .75	18	736-0505	Flat Washer
5	710-3005	Hex Cap Screw 3/8-16 x 1.25	19	736-0507	Special Washer
6	05896A	Drive Clutch Bracket	20	754-0430B	Belt
7	748-0234	Shoulder Spacer	21	756-0967	Auger Pulley
8	756-0985	Pulley Half	22	736-0247	Flat Washer
9	754-0343	V-Belt	23	736-0331	Bell Washer
10	756-0984	Pulley Half	24	710-0696	Hex Cap Screw 3/8-24
11	736-0270	Bell Washer	25	748-0360	Pulley Adapter
12	710-0230	Hex Cap Screw 1/4-28 x .50	26	710-0654A	Hex Washer Screw 3/8-16 x 1.0
13	756-0313	Flat Idler	27	629-0071	Extension Cord, Three-Prong
14	710-1245B	Lock Cap Screw 5/16-24			

# Models E640F, E660F, E6C0F & E660G

**IMPORTANT:** For a proper working machine, use Factory Approved Parts.  
**V-BELTS** are specially designed to engage and disengage safely. A substitute (non OEM) V-Belt can be dangerous by not disengaging completely.

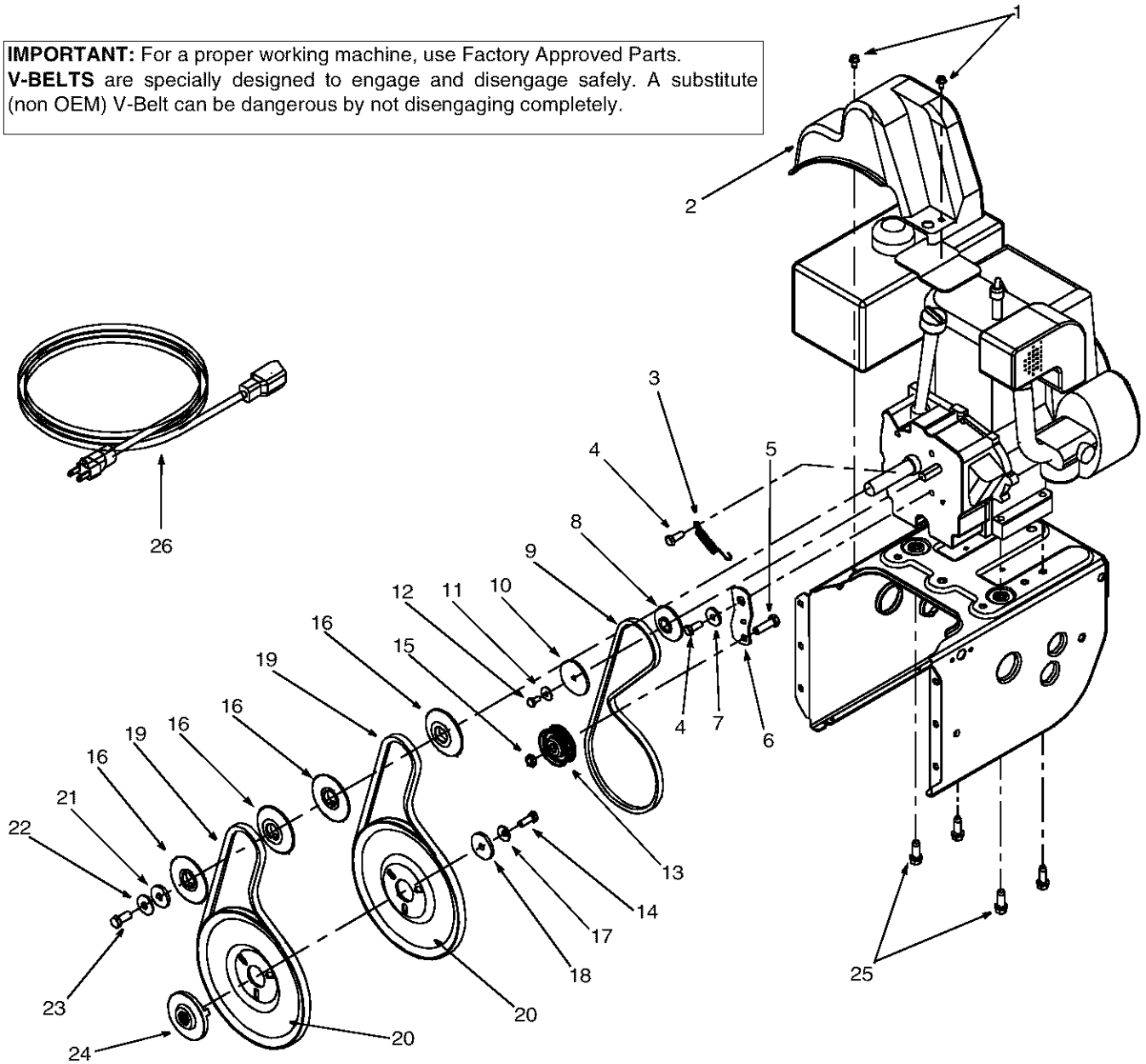

REF. NO.	PART NO.	DESCRIPTION	REF. NO.	PART NO.	DESCRIPTION
1	710-1652	Hex Washer Screw 1/4-20 x .625	14	710-1245A	Lock Hex Cap Screw 5/16-24
2	731-1324	Belt Cover	15	712-0181	Lock Jam Nut 3/8-16
3	732-0710	Extension Spring	16	756-0569	Pulley Half
4	710-0627	Hex Screw 5/16-24 x .75	17	736-0242	Bell Washer
5	710-3005	Hex Cap Screw 3/8-16 x 1.25	18	736-0505	Flat Washer
6	05896A	Drive Clutch Idler Bracket	19	754-0430A	Belt
7	748-0234	Shoulder Spacer	20	756-0967	Auger Pulley
8	756-0987	Pulley Half	21	736-0247	Flat Washer 3/8 x 1.25 OD
9	754-0346	V-Belt	22	736-0331	Bell Washer
10	756-0986	Pulley Half	23	710-0696	Hex Cap Screw 3/8-24
11	736-0270	Bell Washer	24	748-0360	Pulley Adapter
12	710-0230	Hex Cap Screw 1/4-28 x .50	25	710-0654A	Hex Screw 3/8-16 x 1.0
13	756-0313	Flat Idler	26	629-0071	Extension Cord, Three-Prong

# MANUFACTURER'S LIMITED WARRANTY FOR:



The limited warranty set forth below is given by MTD LLC with respect to new merchandise purchased and used in the United States, its possessions and territories.

MTD LLC warrants this product against defects for a period of two (2) years commencing on the date of original purchase and will, at its option, repair or replace, free of charge, any part found to be defective in materials or workmanship. This limited warranty shall only apply if this product has been operated and maintained in accordance with the Operator's Manual furnished with the product, and has not been subject to misuse, abuse, commercial use, neglect, accident, improper maintenance, alteration, vandalism, theft, fire, water, or damage because of other peril or natural disaster. Damage resulting from the installation or use of any accessory or attachment not approved by MTD LLC for use with the product(s) covered by this manual will void your warranty as to any resulting damage.

Normal wear parts or components thereof are subject to separate terms as follows: All normal wear parts or component failures will be covered on the product for a period of 90 days regardless of cause. After 90 days, but within the two year period, normal wear part failures will be covered ONLY IF caused by defects in materials or workmanship of OTHER component parts. Normal wear parts and components include, but are not limited to: batteries, belts, blades, blade adapters, grass bags, rider deck wheels, seats, snow thrower skid shoes, shave plates, auger spiral rubber, tires.

**HOW TO OBTAIN SERVICE:** Warranty service is available, WITH PROOF OF PURCHASE, through your local authorized service dealer. To locate the dealer in your area, check your Yellow Pages, or contact MTD LLC at P.O. Box 361131, Cleveland, Ohio 44136-0019, 1-800-800-7310, 1-330-220-4683 or log on to our Web site at [www.mtdproducts.com](http://www.mtdproducts.com).

This limited warranty does not provide coverage in the following cases:

- a. The engine or component parts thereof. These items carry a separate manufacturer's warranty. Refer to the applicable manufacturer's warranty for terms and conditions.
- b. Log splitter pumps, valves, and cylinders have a separate one year warranty.
- c. Routine maintenance items such as lubricants, filters, blade sharpening, tune-ups, brake adjustments, clutch adjustments, deck adjustments, and normal deterioration of the exterior finish due to use or exposure.
- d. MTD LLC does not extend any warranty for products sold or exported outside of the United States, its possessions and territories, except those sold through MTD LLC's authorized channels of export distribution.
- e. Parts that are not genuine MTD parts are not covered by this warranty.
- f. Service completed by someone other than an authorized service dealer is not covered by this warranty.
- g. Transportation charges and service calls are not covered.

**No implied warranty, including any implied warranty of merchantability of fitness for a particular purpose, applies after the applicable period of express written warranty above as to the parts as identified. No other express warranty, whether written or oral, except as mentioned above, given by any person or entity, including a dealer or retailer, with respect to any product, shall bind MTD LLC. During the period of the warranty, the exclusive remedy is repair or replacement of the product as set forth above.**

**The provisions as set forth in this warranty provide the sole and exclusive remedy arising from the sale. MTD LLC shall not be liable for incidental or consequential loss or damage including, without limitation, expenses incurred for substitute or replacement lawn care services or for rental expenses to temporarily replace a warranted product.**

Some states do not allow the exclusion or limitation of incidental or consequential damages, or limitations on how long an implied warranty lasts, so the above exclusions or limitations may not apply to you.

In no event shall recovery of any kind be greater than the amount of the purchase price of the product sold. **Alteration of safety features of the product shall void this warranty.** You assume the risk and liability for loss, damage, or injury to you and your property and/or to others and their property arising out of the misuse or inability to use the product.

This limited warranty shall not extend to anyone other than the original purchaser or to the person for whom it was purchased as a gift.

**HOW STATE LAW RELATES TO THIS WARRANTY: This limited warranty gives you specific legal rights, and you may also have other rights which vary from state to state.**