

**GENERAC®**  
Portable Products

# 6500EXL

*Portable Generator Owner's Manual*

**Problems?  
Questions?**

Before taking your unit  
back to the store,  
call the generator  
helpline at  
**1-800-270-1408**  
M-F 8-5 CT

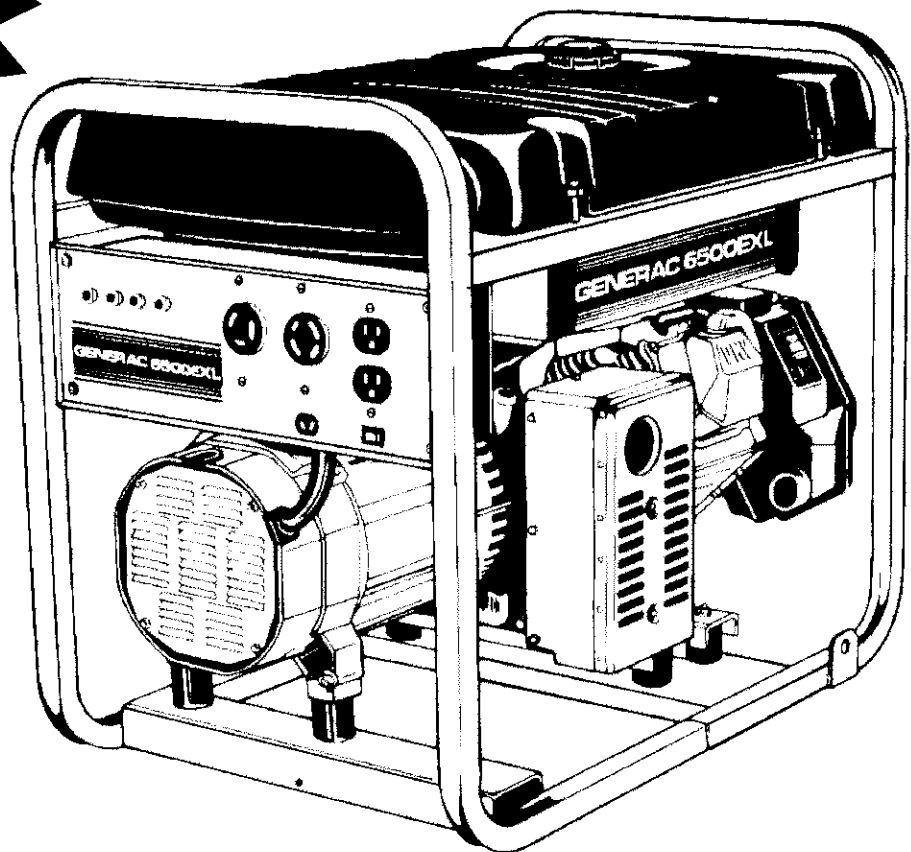

Model No. 9798-2 (6,500 Watt AC Generator) Manual No. B2649 Revision 3 (06/01/2001)

Visit our Generac website: [www.generac-portables.com](http://www.generac-portables.com)



This is the safety alert symbol. It is used to alert you to potential personal injury hazards. Obey all safety messages that follow this symbol to avoid possible injury or death.



## EQUIPMENT DESCRIPTION

This generator is an engine-driven, revolving field, alternating current (AC) generator. It was designed to supply electrical power for operating compatible electrical lighting, appliance, tools and motor loads. This manual contains information for a generator that operates 120 and/or 240 Volt, single phase, 60 Hz devices that require up to 6,500 watts (6.5 kW) of power that pull up to 54.2 Amps at 120 Volts or 27.1 Amps at 240 Volts.

**CAUTION! Do Not** exceed the generator's wattage/ampere capacity. The total load should not be greater than 6,500 watts. See "Don't Overload the Generator" on page 11.

The generator's revolving field is driven at about 3,600 rpm by a single-cylinder engine.

Every effort has been made to ensure that information in this manual is accurate and current. However, Generac reserves the right to change, alter or otherwise improve the product and this document at any time without prior notice.



**CAUTION! Do Not** tamper with engine governed speed. High operating speeds are dangerous and increase risk of personal injury or damage to equipment. The generator supplies correct rated frequency and voltage only when running at proper governed speed. Incorrect frequency and/or voltage can damage some connected electrical loads. Operating at excessively low speeds imposes a heavy load. When adequate engine power is not available engine life may be shortened.

The Emission Control System for this generator is warranted for standards set by the Environmental Protection Agency. For warranty information refer to the engine owner's manual.

## SAFETY RULES

This generator set was designed and manufactured for specific applications. **Do Not** attempt to modify the unit or use it for any application it was not designed for. If you have any questions about your generator's application, ask your dealer or consult the factory.

The manufacturer could not possibly anticipate every circumstance that might involve a hazard. For that reason warnings in the manual and warnings on tags or decals affixed to the unit are not all-inclusive. If you intend to handle, operate or service the unit by a procedure or method not specifically recommended by the manufacturer, first make sure that such a procedure or method will not render this equipment unsafe or pose a threat to you and others.

**Read this manual carefully and become familiar with your generator set. Know its applications, its limitations and any hazards involved.**



### WARNING:



**The engine exhaust from this product contains chemicals known to the State of California to cause cancer, birth defects, or other reproductive harm.**



**DANGER! You must** isolate the generator from the electric utility using approved transfer equipment if this unit is used for backup power. **Failure to isolate the generator from the power utility may result in injury or death to electric utility workers and damage to the generator** due to a backfeed of electrical energy. Whenever unit is providing backup power, the electric utility must be notified.



**DANGER! Generator exhaust gases contain DEADLY carbon monoxide gas. If breathed in sufficient concentrations, carbon monoxide can cause unconsciousness or death.** Operate this equipment outdoors where adequate ventilation is available.



- The generator produces a very powerful voltage that can cause serious injury or death by electrocution. **Never** touch bare wires or receptacles. **Never** permit a child or any unqualified person to operate the generator.
- **Never** handle any kind of electrical cord or device while standing in water, while barefoot or while hands or feet are wet. Death or serious injury from electrocution may result.
- Use a ground fault circuit interrupter (GFCI) in any damp or highly conductive area (such as metal decking or steel work).
- **Never** use worn, bare, frayed or otherwise damaged electrical cords with the generator. Death, serious injury and property damage from electrical shock may result.
- **Gasoline is highly FLAMMABLE and its vapors are EXPLOSIVE. Never allow smoking, open flames, sparks or heat in the vicinity while handling gasoline.** Avoid spilling gasoline on a hot engine. Comply with all laws regulating storage and handling of gasoline.
- **Do Not** overfill the fuel tank. Always allow room for fuel expansion. **If tank is overfilled, fuel can overflow onto a hot engine and cause a FIRE or an EXPLOSION.**
- **Never** store a generator with fuel in the tank where gasoline vapors might reach an open flame, spark or pilot light (as on a furnace, water heater, clothes dryer). FIRE or an EXPLOSION may result.
- The unit requires an adequate flow of cooling air for its continued proper operation. **Never** operate the unit inside any room or enclosure where the free flow of cooling air into and out of the unit might be obstructed. Allow at least 2 feet of clearance on all sides of generator, even while operating unit outdoors, or you could damage the unit.
- **Never** start, or stop the unit with electrical loads connected to receptacles with the connected devices turned ON. Start the engine and let it stabilize before connecting any electrical loads. Disconnect all electrical loads before shutting down the generator.
- **Do Not** insert any object through cooling slots of the engine. You could damage the unit or injure yourself.

- **Never operate the generator:** in rain; in any enclosed compartment; when connected electrical devices overheat; if electrical output is lost; if engine or generator sparks; if flame or smoke is observed while unit is running; if unit vibrates excessively.

## GROUNDING THE GENERATOR

The National Electrical Code requires that the frame and external electrically conductive parts of this generator be properly connected to an approved earth ground. Local electrical codes may also require proper grounding of the unit. For that purpose, a **GROUNDING WING NUT** is provided on the generator end (Figure 1).

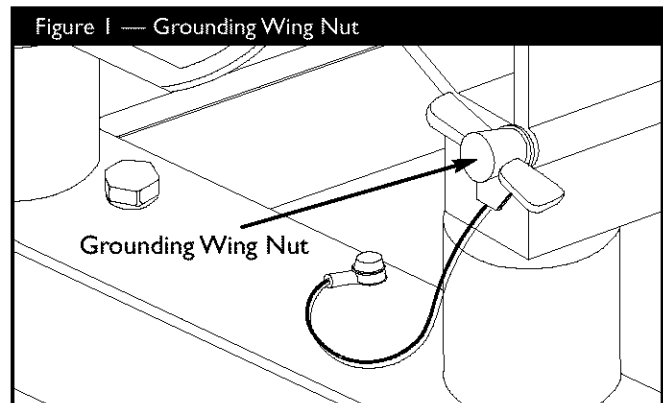

Generally, connecting a No. 12 AWG (American Wire Gauge) stranded copper wire to the grounding wing nut and to an earth-driven copper or brass grounding rod (electrode) provides adequate protection against electrical shock. Be careful to keep the grounding wire attached after connecting the stranded copper wire. However, local codes may vary widely. Consult with a local electrician for grounding requirements in your area.

Properly grounding the generator helps prevent electrical shock if a ground fault condition exists in the generator or in connected electrical devices. Proper grounding also helps dissipate static electricity, which often builds up in ungrounded devices.

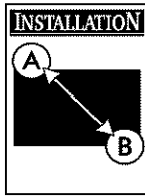

Your generator requires some assembly and is ready for use after it has been properly serviced with the recommended oil and fuel.

**If you have any problems with the assembly of your generator, please call the generator helpline at 1-800-270-1408.**

**IMPORTANT:** Any attempt to run the unit before it has been serviced with the recommended oil will result in an engine failure.

## REMOVE GENERATOR FROM CARTON

- Set the carton on a rigid flat surface with “This Side Up” arrows pointing upward.
- Carefully open the top flaps of the shipping carton. Review “Cold Weather Operation” on page 9.
- Cut down corners at one end of carton from top to bottom and lay that side of carton down flat.
- Remove all packing material, carton fillers, etc.
- Remove the generator from the shipping carton.

## CARTON CONTENTS

Check all contents. If any parts are missing or damaged, call the generator helpline at **1-800-270-1408**.

- The generator
- Electric start battery cables
- Generator and engine owner's manuals
- Locking 30 Amp plugs
- Battery charge cables
- Battery tray mounting bracket/hardware
- Spare spark plug and air filter element
- Spark plug wrench

## INSTALLING TRAY AND BATTERY

You must purchase and install a 12 Volt DC battery (Series U1L). The battery should be serviced with electrolyte fluid and fully charged prior to installation. Install the battery as follows:

- Find the battery tray and fasteners shipped loose in the carton.
- Remove the four battery tray screws from cradle.
- Position the battery tray and install with supplied hardware (see Figure 2).

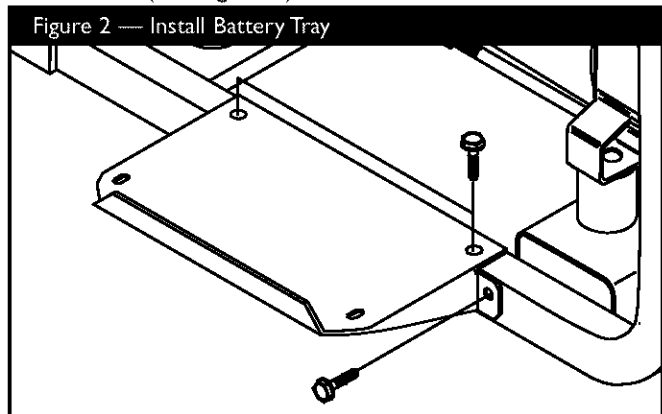

- Set battery onto tray.
- Retain battery to tray with one battery hold down bracket, two J bolts, two lock washers, two flat washers and two hex nuts (Figure 3).

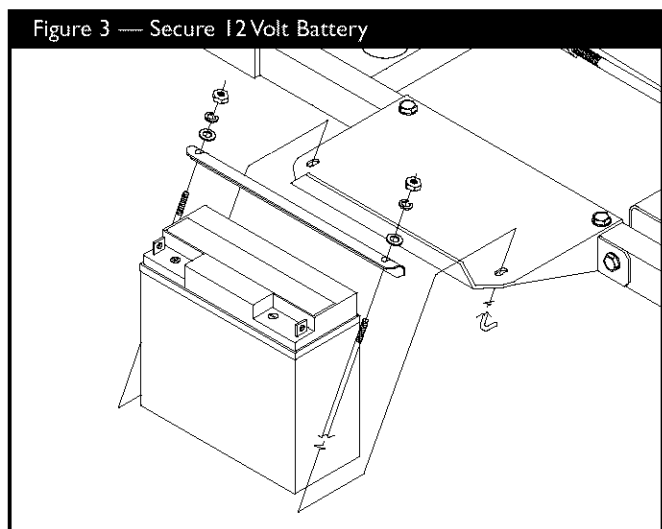

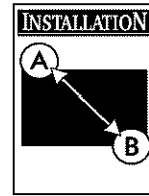

- Connect the **red battery cable** from the engine starter switch to **positive (+)** terminal on the battery (Figure 4).

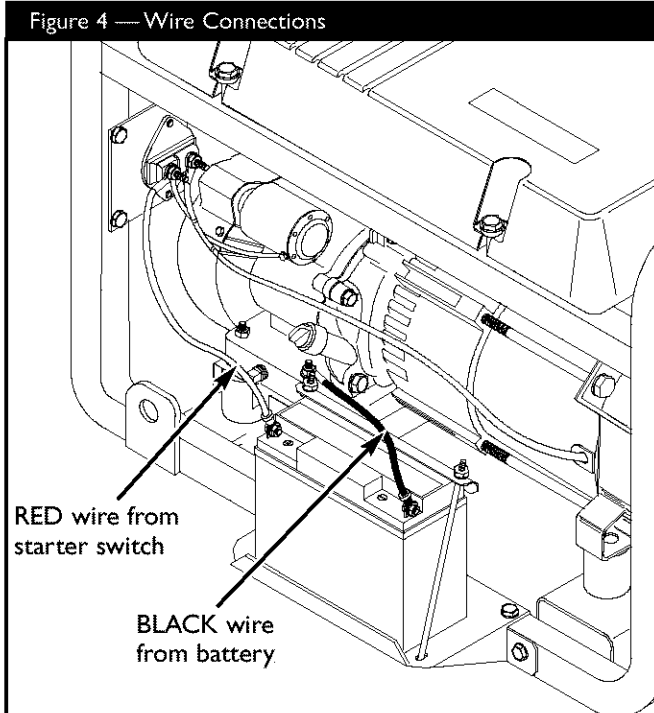

- Connect the **black battery cable** to the **negative (-)** terminal on the battery (Figure 4).
- Connect the other end of the black cable to the engine, **not the frame** (Figure 4).

**CAUTION!** Be sure the **BLACK** cable is connected to the engine mount and not the frame. You could damage the ground wire.

## BEFORE STARTING THE ENGINE

### Add Oil

**CAUTION!** Any attempt to crank or start the engine before it has been properly filled with the recommended oil may result in an engine failure.

#### To fill your engine with oil:

- Place generator on a level surface.

- Follow the oil grade recommendations and oil fill instructions given in the engine owner's manual.

**NOTE:** The generator's revolving field rides on a prelubricated and sealed ball bearing that requires no additional lubrication for the life of the bearing.

### Add Gasoline

**WARNING!** Never fill fuel tank indoors. Never fill fuel tank when engine is running or hot. **Do Not** light a cigarette or smoke when filling the fuel tank.

**WARNING!** **Do Not** overfill the fuel tank. Always allow room for fuel expansion.

- Use regular **UNLEADED** gasoline with the generator engine. **Do Not** use premium gasoline. **Do Not** mix oil with gasoline.
- Clean area around fuel fill cap, remove cap.
- Slowly add unleaded regular gasoline to fuel tank. Be careful not to overfill. Allow about 1/2" of tank space for fuel expansion (Figure 5).

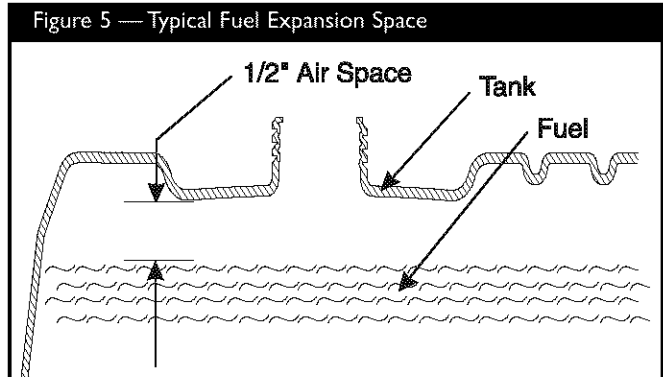

- Install fuel cap and wipe up any spilled gasoline.

**IMPORTANT:** It is important to prevent gum deposits from forming in essential fuel system parts, such as the carburetor, fuel filter, fuel hose or tank during storage. Also, experience indicates that alcohol-blended fuels (called gasohol, ethanol or methanol) can attract moisture, which leads to separation and formation of acids during storage. Acidic gas can damage the fuel system of an engine while in storage.

To avoid engine problems, the fuel system should be emptied before storage of 30 days or longer. See "Storage" on page 12. **Never** use engine or carburetor cleaner products in the fuel tank or permanent damage may occur.



## KNOW YOUR GENERATOR

Read this owner's manual and safety rules before operating your generator.

Compare the illustrations with your generator, to familiarize yourself with the locations of various controls and adjustments. Save this manual for future reference.

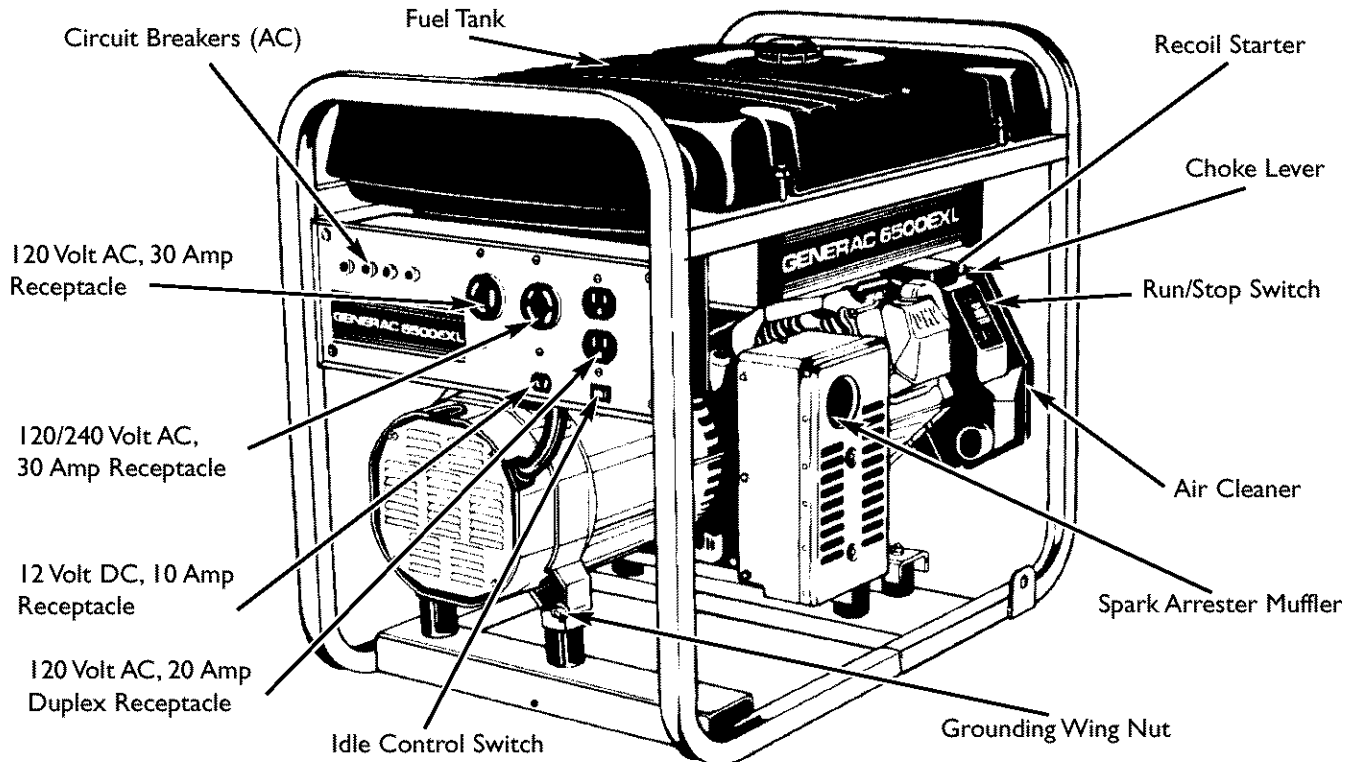

**12 Volt DC, 10 Amp Receptacle** — Recharge a discharged 12 Volt automotive type battery through this receptacle.

**120 Volt AC, 20 Amp, Duplex Receptacle** — May be used to supply electrical power for the operation of 120 Volt AC, 20 Amp, single phase, 60 Hz electrical lighting, appliance, tool and motor loads.

**120 Volt AC, 30 Amp Locking Receptacle** — May be used to supply electrical power for the operation of 120 Volt AC, 30 Amp, single phase, 60 Hz electrical lighting, appliance, tool and motor loads.

**120/240 Volt AC, 30 Amp Locking Receptacle** — May be used to supply electrical power for the operation of 120 and/or 240 Volt AC, 30 Amp, single phase, 60 Hz electrical lighting, appliance, tool and motor loads.

**Air Cleaner** — Uses a dry type filter element and foam pre-cleaner to limit the amount of dirt and dust sucked into the engine.

**Choke Lever** — Used when starting a cold engine.

**Circuit Breakers (AC)** — Each receptacle is provided with a "push to reset" circuit breaker to protect the generator against electrical overload.

**Fuel Tank** — Capacity of seven (7) U.S. gallons.

**Grounding Wing Nut** — Used for proper grounding of unit.

**Idle Control Switch** — With this switch set to ON, printed circuit board in control panel automatically reduces engine speed when no load is connected and increases engine to proper speed when load is applied. However, be sure switch is OFF when starting engine.

**Recoil starter** — Used to start the engine.

**Run/Stop Switch** — Set this switch to "Run" before using recoil starter. Set switch to "Stop" to switch OFF engine.

**Spark Arrester Muffler** — Exhaust muffler lowers engine noise and is equipped with a spark arrester screen.



## OPERATING THE GENERATOR



**CAUTION!** Never start or stop the engine with electrical loads connected to the receptacles AND with the connected devices turned ON.

### Starting the Engine

- Unplug **all** electrical loads from generator receptacles before starting the engine.
- Make sure the unit is in a level position.
- Open the fuel shut-off valve (Figure 6).

Figure 6 — Fuel Shut-off Valve

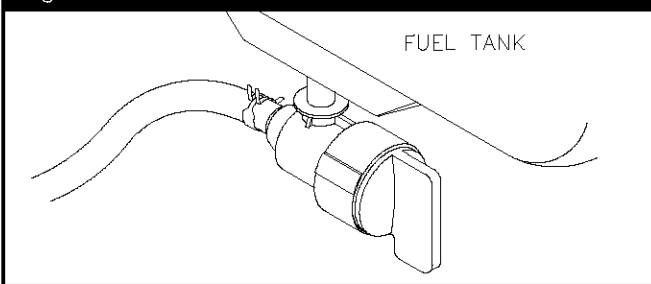

- Make sure the Idle Control switch is “Off”.
- Place Run/Stop switch in the “Run” position (Figure 7).

Figure 7 — Run/Stop Switch

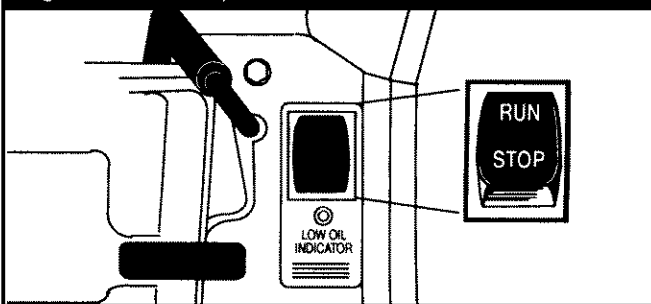

- Place the choke lever in the “Full” choke position by sliding it to the left toward the valve cover in the direction indicated by the arrow (Figure 8).

Figure 8 — Choke Lever

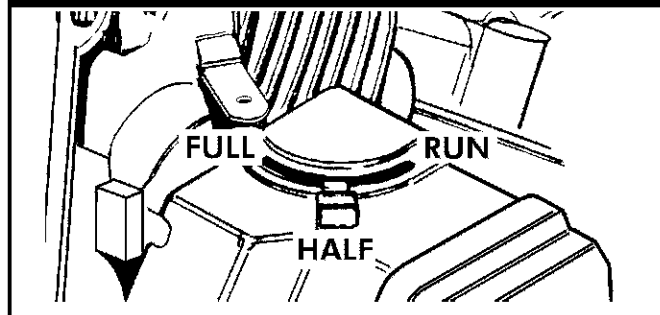

- Grasp starter grip and pull slowly until you feel slight resistance, then **pull quickly**. **Do Not** let handle “snap-back” into recoil housing.
- When engine starts, move choke lever to “Run” position by sliding it all the way to the right (away from the valve cover and under the arrow).

**NOTE:** If engine fails to start after 3 pulls, move the choke lever to “Half” choke position and pull starter rope again 2 times.

**NOTE:** If the engine still fails to start, review the engine owner’s manual. Also, check for proper oil level in crankcase. Unit is equipped with a low oil shutdown system. See engine owner’s manual for information regarding the low oil shutdown system.

### Connecting Electrical Loads

- Let engine stabilize and warm up for a few minutes after starting.
- Plug in and turn on the desired 120 and/or 240 Volt AC, single phase, 60 Hz electrical loads.
- **Do Not** connect 240 Volt loads to the 120 Volt receptacles.
- **Do Not** connect 3-phase loads to the generator.
- **Do Not** connect 50 Hz loads to the generator.
- **DO NOT OVERLOAD THE GENERATOR.** Add up the rated watts (or amps) of all loads to be connected at one time. This total should not be greater than the rated wattage/ampere capacity of the generator. See “Don’t Overload the Generator” on page 11.



## Stopping the Engine

- Unplug **all** electrical loads from generator panel receptacles. **Never** start or stop engine with electrical devices plugged in and turned on.
- Put the idle control switch in the “**Off**” position.
- Let engine run at no-load for 30 seconds to stabilize the internal temperatures of engine and generator.
- Move run/stop switch to “**Stop**”.
- Close the fuel shut-off valve.

## Operating Automatic Idle Control

This switch is designed to greatly improve fuel economy.

**When this switch is turned ON**, the engine will only run at its normal high governed engine speed when an electrical load is connected. When an electrical load is removed, the engine will run at a reduced speed. **With the switch off**, the engine will run at the normal high engine speed. **Always have the switch off when starting and stopping the engine.**

## Charging a Battery

**WARNING!** Storage batteries give off explosive hydrogen gas while recharging. An explosive mixture will remain around the battery for a long time after it has been charged. The slightest spark can ignite the hydrogen and cause an explosion, resulting in blindness or other serious injury.

**WARNING! Do Not** permit smoking, open flame, sparks or any other source of heat around a battery. Wear protective goggles, rubber apron and rubber gloves when working around a battery. Battery electrolyte fluid is an extremely caustic sulfuric acid solution that can cause severe burns. If spill occurs flush area with clear water immediately.

Your generator has the capability of recharging a discharged 12 Volt automotive or utility style storage battery. **Do Not** use the unit to charge any 6 Volt batteries. **Do Not** use the unit to crank an engine having a discharged battery.

**To recharge 12 Volt batteries, proceed as follows:**

- Check fluid level in all battery cells. If necessary, add **ONLY** distilled water to cover separators in battery cells. **Do Not use tap water.**
- If the battery is equipped with vent caps, make sure they are installed and are tight.
- If necessary, clean battery terminals.
- Connect battery charge cable connector plug to panel receptacle identified by the words “12 VOLTS D.C.”
- Connect battery charge cable clamp with **red** handle to the **positive (+)** battery terminal (Figure 9).

Figure 9 — Battery Connections

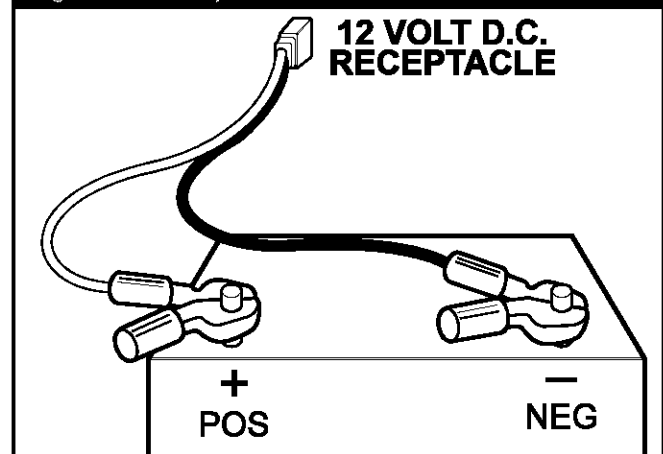

- Connect battery charge cable clamp with **black** handle to the **negative (-)** battery terminal (Figure 9).
- Start engine. Let the engine run while battery recharges.
- When battery has charged, shut down engine

**NOTE:** Use an automotive hydrometer to test battery state of charge and condition. Follow the hydrometer manufacturer's instructions carefully. Generally, a battery is considered to be at 100% state of charge when specific gravity of its fluid (as measured by hydrometer) is 1.260 or higher.





## COLD WEATHER OPERATION

Under certain weather conditions (temperatures below 40°F [4°C] and a high dew point), your generator may experience icing of the carburetor and/or the crankcase breather system.

In an emergency, use the original shipping box as a temporary shelter:

- Cut off all flaps.
- Cut out one of the long sides of the box to expose exhaust side of unit. Ensure a minimum of two feet clearance between open side of box and nearest object.
- Cut appropriate slots to access receptacles of unit.
- Start unit, then place box over it.

**IMPORTANT:** Remove shelter when temperature is above 40°F [4°C].

For a more permanent shelter, build a structure that will enclose three sides and the top of the generator:

- Make sure entire muffler-side of generator is exposed. Note that your generator may appear different from that shown in Figure 10.

Figure 10 — Temporary Cold Weather Shelter

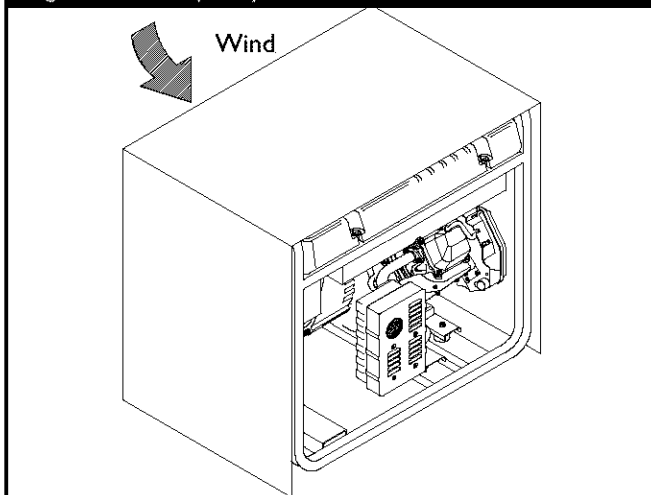

- Ensure a minimum of two feet clearance between open side of box and nearest object.
- Face exposed end away from wind and elements.
- Enclosure should hold enough heat created by the generator to prevent problems.



**CAUTION!** Never run unit indoors. Do Not enclose generator any more than shown.

## RECEPTACLES

### 120/240 Volt AC, 30 Amp, Locking Receptacle

Use a NEMA L14-30 plug with this receptacle. Connect a 4-wire cord set rated for 250 Volt AC loads at 30 Amps (or greater) (Figure 11). You can use the same 4-wire cord if you plan to run a 120 Volt load.

Figure 11 — 120/240 Volt AC, 30 Amp, Locking Receptacle

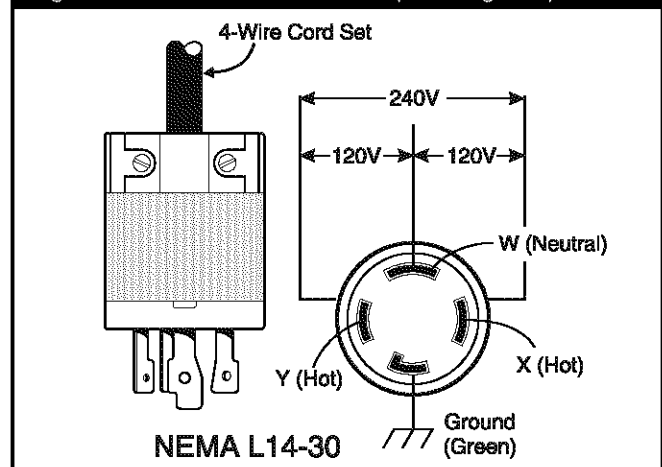

This receptacle powers 120/240 Volt AC, 60 Hz, single phase loads requiring up to 3,600 watts of power at 30 Amps for 120 Volts; 6,500 watts of power (6.5 kW) at 30 Amps for 240 Volts. The outlet is protected by a 30 Amp push-to-reset circuit breaker.



**CAUTION!** Although this outlet states it has a 240 Volt 30 Amp rating (up to 7,200 watts), the generator is only rated for 6,500 watts. Powering loads that exceed the wattage/ampere capacity of the generator can damage it or cause serious injuries.

### 120 Volt AC, 30 Amp Locking Receptacle

Use a NEMA L5-30 plug with this receptacle. Connect a 3-wire cord set rated for 125 Volt AC loads at 30 Amps to the plug (Figure 12).

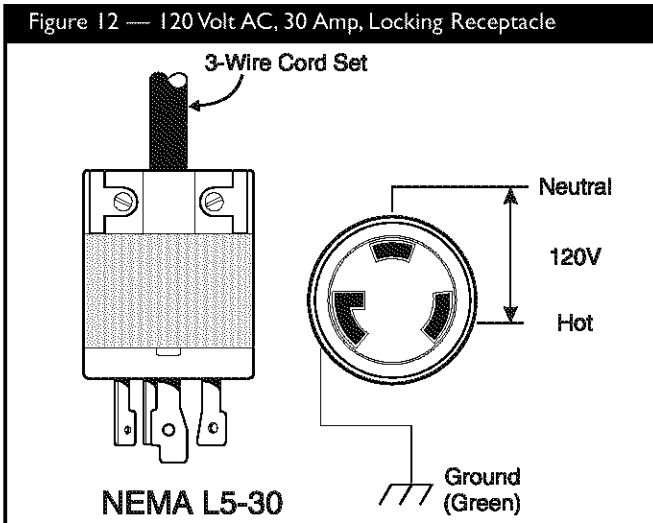

Use this receptacle to operate 120 Volt AC, 60 Hz, single phase loads requiring up to 3,600 watts (3.6 kW) of power at 30 Amps. The outlet is protected by a 30 Amp push-to-reset circuit breaker.

### 120 Volt AC, 20 Amp, Duplex Receptacle

Each receptacle (Figure 13) is protected against overload by a 20 Amp push-to-reset circuit breaker.

Use each receptacle to operate 120 Volt AC, single-phase, 60 Hz electrical loads requiring up to 2,400 watts (2.4 kW) at 20 Amps of current. Use cord sets that are rated for 125 Volt AC loads at 20 Amps (or greater).

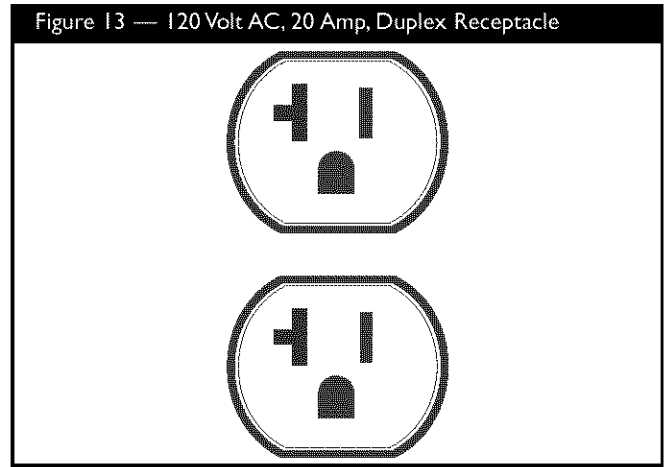

### 12 Volt DC, 10 Amp Receptacle

This receptacle allows you to recharge a 12 Volt automotive or utility style storage battery with the battery charge cables provided (Figure 14). This receptacle can not recharge 6 Volt batteries and can not be used to crank an engine having a discharged battery. See the section “Charging a Battery” (page 8) before attempting to recharge a battery.

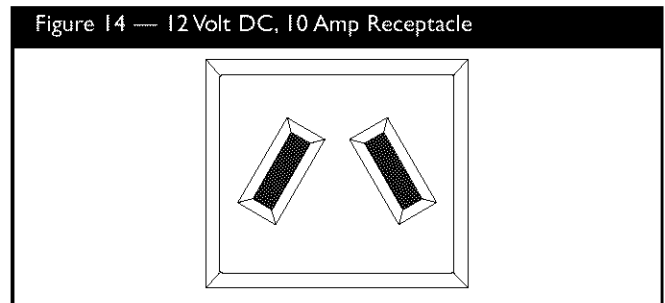



## DON'T OVERLOAD THE GENERATOR

Overloading a generator in excess of its rated wattage capacity can result in damage to the generator and/or connected electrical devices. Observe the following, to prevent overloading the unit:

- Add up the total wattage of all electrical devices to be connected at one time. This total should NOT be greater than the generator's wattage capacity.
- If the appliance, tool or motor does not give wattage, multiply 120 Volts times ampere rating to determine watts (volts x amps = watts).
- The rated wattage of lights can be taken from wattage listed on the light bulbs. The rated wattage of tools, appliances and motors can usually be found on a data plate or decal affixed to the device. Use Figure 15 below as a general reference.
- Some electric motors, such as induction types, require about three times more watts of power for starting than for running. This surge of power lasts for only a few seconds when starting such motors. Be sure you allow for this high starting wattage when selecting electrical devices to connect to your generator. First figure the watts needed to start the largest motor. Add to that figure the running watts of all other connected loads.

Figure 15 — Wattage Reference Guide

Recreational/Home Uses		Professional/Contractor Uses	
Tool/Appliance.....	Watts	Tool/Appliance.....	Watts
AM/FM clock radio .....	50	*1/3 hp airless sprayer .....	600
Light bulb.....	100	3/8" hammer drill.....	600
Fan.....	200	Variable speed Sawzall® .....	960
20" color TV .....	400	½" power drill.....	1000
*Deep freezer .....	500	Quartz-halogen work light .....	1000
Personal computer and 15" monitor.....	800	Belt sander.....	1200
*1/3 hp furnace fan blower.....	800	7 ¼" circular saw.....	1500
Microwave oven.....	800	7 ¼" worm drive saw.....	1600
*18 cu ft refrigerator.....	800	*1½ hp air compressor.....	1800
Sump pump.....	1000	*10" power miter saw.....	1800
Electric skillet.....	1250	6" bench grinder.....	1800
*½ hp water well pump.....	1400	*6" table planer.....	1800
*12,000 Btu window air conditioner .....	1400	*10" table/radial arm saw.....	2000
Space heater.....	1800	Wire feed welder.....	2400
Electric water heater .....	4000		

\* allow 3 times listed watts for starting this device

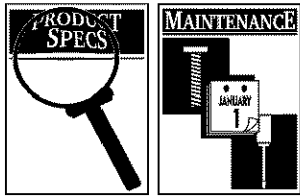

## SPECIFICATIONS

Maximum Surge Watts	8,125 watts
Continuous Wattage Capacity	6,500 watts
Power Factor	1.0
Rated Maximum Continuous AC Load Current:	
At 120 Volts	54.2 Amps
At 240 Volts	27.1 Amps
Phase	1-phase
Rated Frequency	60 Hertz
Fuel Tank Capacity	7 U.S. gallons
Shipping Weight	200 lbs.

## GENERAL MAINTENANCE RECOMMENDATIONS

The Owner/Operator is responsible for making sure that all periodic maintenance tasks are completed on a timely basis; that all discrepancies are corrected; and that the unit is kept clean and properly stored. **Never operate a damaged or defective generator.**

### Engine Maintenance

See engine owner's manual for instructions.

**CAUTION!** Avoid prolonged or repeated skin contact with used motor oil. Used motor oil has been shown to cause skin cancer in certain laboratory animals. Thoroughly wash exposed areas with soap and water.  
KEEP OUT OF REACH OF CHILDREN. DON'T POLLUTE. CONSERVE RESOURCES. RETURN USED OIL TO COLLECTION CENTERS.

### Generator Maintenance

Generator maintenance consists of keeping the unit clean and dry. Operate and store the unit in a clean dry environment where it will not be exposed to excessive dust, dirt, moisture or any corrosive vapors. Cooling air slots in the generator must not become clogged with snow, leaves or any other foreign material.

**NOTE: Do Not** use a garden hose to clean generator. Water can enter engine fuel system and cause problems. In addition, if water enters generator through cooling air slots, some of the water will be retained in voids and cracks of

the rotor and stator winding insulation. Water and dirt buildup on the generator internal windings will eventually decrease the insulation resistance of these windings.

### To Clean the Generator

- Use a damp cloth to wipe exterior surfaces clean.
- A soft bristle brush may be used to loosen caked on dirt or oil.
- A vacuum cleaner may be used to pick up loose dirt and debris.
- Low pressure air (not to exceed 25 psi) may be used to blow away dirt. Inspect cooling air slots and opening on generator. These openings must be kept clean and unobstructed.

## STORAGE

The generator should be started at least once every seven days and allowed to run at least 30 minutes. If this cannot be done and you must store the unit for more than 30 days, use the following guidelines to prepare it for storage.

### Generator Storage

- Clean the generator as outlined in "To Clean the Generator."
- Check that cooling air slots and openings on generator are open and unobstructed.

**CAUTION!** Storage covers can be flammable. **Do Not** place a storage cover over a hot generator. Let the unit cool for a sufficient time before placing the cover on the unit.

### Engine Storage

See engine owner's manual for instructions.

### Other Storage Tips

- **Do Not** store gasoline from one season to another.
- Replace gasoline can if it starts to rust. Rust and/or dirt in gasoline can cause problems when that fuel is used with this unit.
- Store in clean and dry area.



## TROUBLESHOOTING

Problem	Cause	Correction
Engine is running, but no AC output is available.	<ol style="list-style-type: none"> <li>One of the circuit breakers is open.</li> <li>Fault in generator.</li> <li>Poor connection or defective cord set.</li> <li>Connected device is bad.</li> </ol>	<ol style="list-style-type: none"> <li>Reset circuit breaker.</li> <li>Contact Generac service facility.</li> <li>Check and repair.</li> <li>Connect another device that is in good condition.</li> </ol>
Engine runs good at no-load but "bogs" down when loads are connected.	<ol style="list-style-type: none"> <li>Short circuit in a connected load.</li> <li>Engine speed is too slow.</li> <li>Generator is overloaded.</li> <li>Shorted generator circuit.</li> </ol>	<ol style="list-style-type: none"> <li>Disconnect shorted electrical load.</li> <li>Contact Generac service facility.</li> <li>See "Don't Overload the Generator" on page 11.</li> <li>Contact Generac service facility.</li> </ol>
Engine will not start; or starts and runs rough.	<ol style="list-style-type: none"> <li>Run/Stop Switch set to "STOP".</li> <li>Dirty air cleaner.</li> <li>Out of gasoline.</li> <li>Stale gasoline.</li> <li>Spark plug wire not connected to spark plug.</li> <li>Bad spark plug.</li> <li>Water in gasoline.</li> <li>Overchoking.</li> <li>Excessively rich fuel mixture.</li> <li>Intake valve stuck open or closed.</li> <li>Engine has lost compression.</li> <li>Failed battery.</li> </ol>	<ol style="list-style-type: none"> <li>Set switch to "RUN".</li> <li>Clean or replace air cleaner.</li> <li>Fill fuel tank.</li> <li>Drain gas tank; fill with fresh fuel.</li> <li>Connect wire to spark plug.</li> <li>Replace spark plug.</li> <li>Drain gas tank; fill with fresh fuel.</li> <li>Open choke fully and crank engine.</li> <li>Contact Generac service facility.</li> <li>Contact Generac service facility.</li> <li>Contact Generac service facility.</li> <li>Replace battery.</li> </ol>
Engine shuts down during operation.	<ol style="list-style-type: none"> <li>Out of gasoline.</li> <li>Low oil level.</li> </ol>	<ol style="list-style-type: none"> <li>Fill fuel tank.</li> <li>Fill crankcase to proper level.</li> </ol>
Engine lacks power.	<ol style="list-style-type: none"> <li>Load is too high.</li> <li>Dirty air filter.</li> </ol>	<ol style="list-style-type: none"> <li>See "Don't Overload the Generator" on page 11.</li> <li>Replace air filter.</li> </ol>
Engine "hunts" or falters.	<ol style="list-style-type: none"> <li>Choke is opened too soon.</li> <li>Carburetor is running too rich or too lean.</li> </ol>	<ol style="list-style-type: none"> <li>Move choke to halfway position until engine runs smoothly.</li> <li>Contact Generac service facility.</li> </ol>



# SCHEMATIC

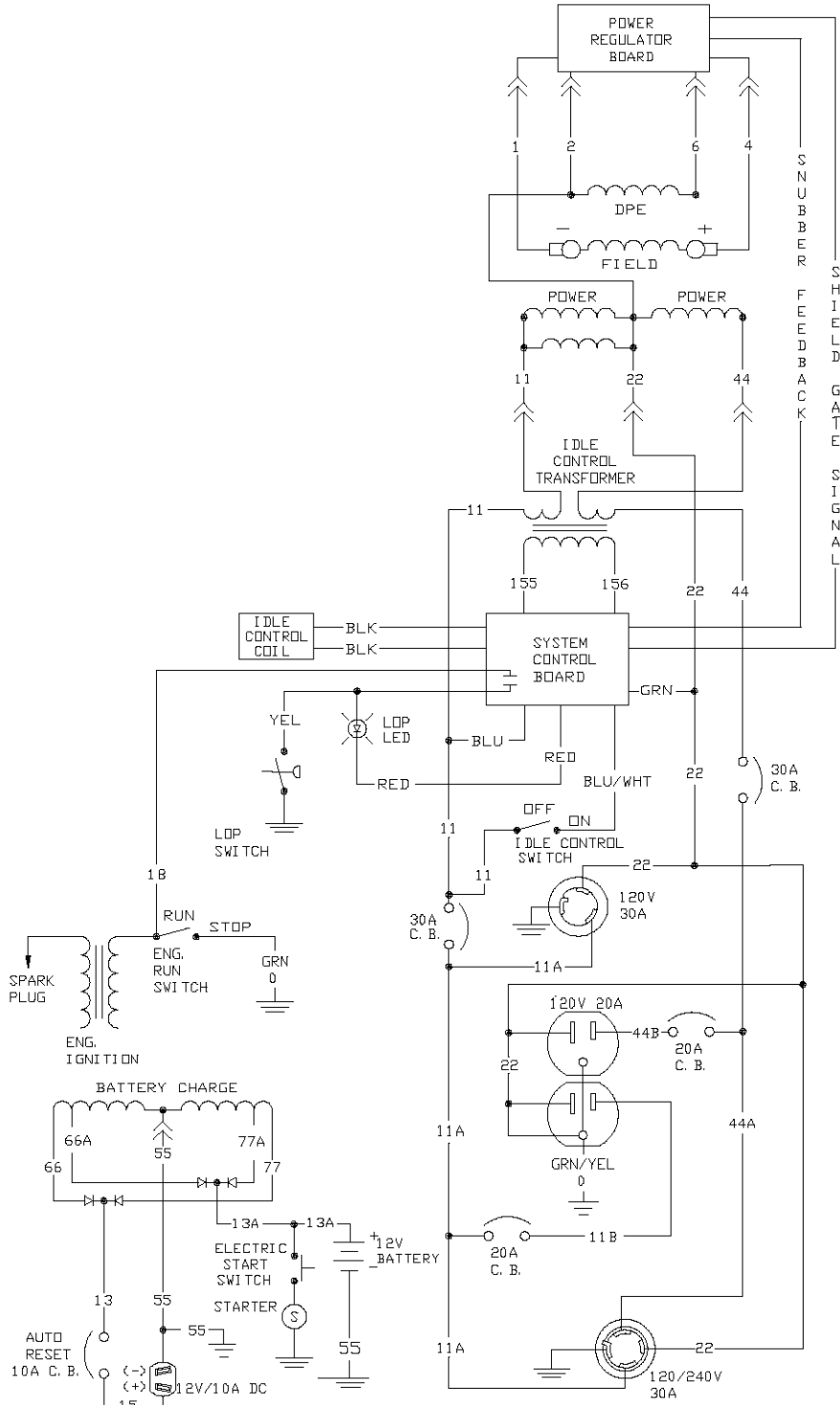



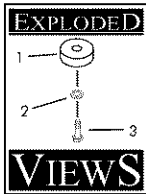

# EXPLODED VIEW - MAIN UNIT

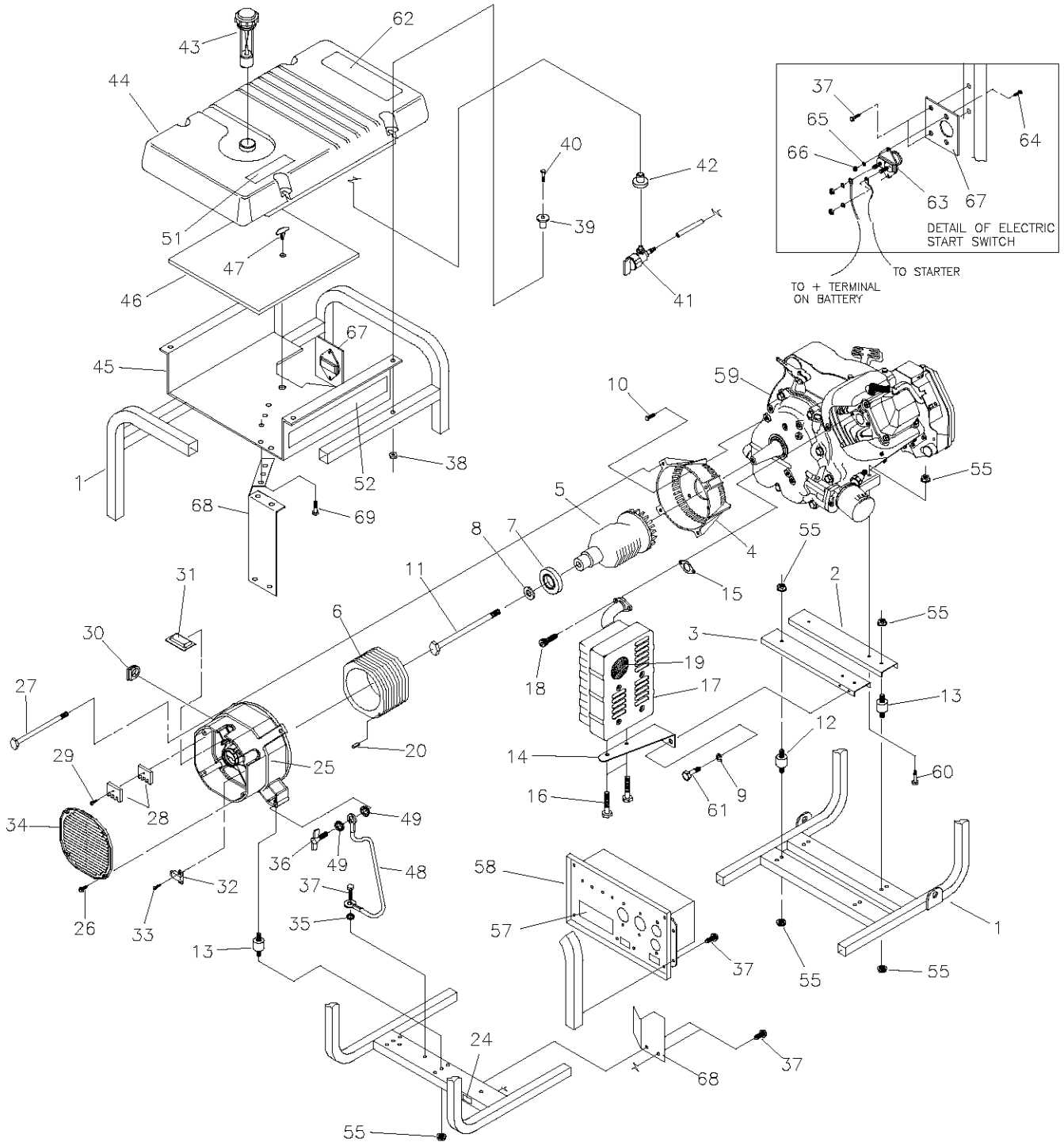



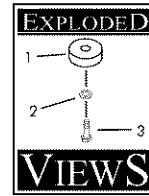

## PARTS LIST – MAIN UNIT

Item	Part #	Qty	Description	Item	Part #	Qty	Description
1	A92432	1	CRADLE	46	92665	1	INSULATION, #2-1/4"
2	A92531	1	SUPPORT, Engine	47	85000	1	CLIP, Insulation
3	A92731	1	SUPPORT, Engine & Muffler	48	14353621	1	WIRE, Ground
4	92247	1	HOUSING, Engine Adapter	49	26850	2	WASHER, M6 Shakeproof
5	92679G	1	ASSEMBLY, Rotor (Incls Item 7)	51	92982	1	DECAL, Danger
6	94981G	1	ASSEMBLY, Stator	52	96059	2	DECAL, Heat Shield
7	65791	1	BEARING	55	189160	12	NUT, 5/16-18 Serrated Flange
8	67451	1	WASHER, M8 Flat	57	96060	1	DECAL, Control Panel
9	22129	2	WASHER, M8 Lock	58	92630	1	ASSEMBLY, Control Box
10	86307	4	SCREW, 5/16-24 x 3/4 SEMS	59	NSP	1	ENGINE
11	25254	1	SCREW, 5/16-24 x 9-7/8"	60	22531	2	SCREW, 5/16-18 x 1-3/4"
12	92609	2	MOUNT, Vibration	61	22142	2	SCREW, 5/16 - 18 x 3/4"
13	82857	4	MOUNT, Vibration	62	93826	1	DECAL, Start Instructions
14	92532	1	BRACKET, Muffler	63	77282	1	SWITCH, Starter
15	90239	1	GASKET, Exhaust	64	22287	2	SCREW, 1/4 - 20" x 3/4"
16	66476	2	SCREW, M6-1 x 12 with Lock Washer	65	22097	2	WASHER, M6 Lock
17	A7433	1	MUFFLER	66	22127	2	NUT, 1/4 - 20" Hex
18	40976	2	SCREW, M8 - 1.25 x 20	67	78289	1	BRACKET, Starter Switch
19	83083	1	SCREEN, Spark Arrest	68	B96068	1	SHIELD, Heat
20	81917	1	PIN, 4mm x 10 Roll	69	56893	5	CRIMPTITE, 10 - 24 x 1/2
24	B4986	1	DECAL, Ground				
25	66825C	1	CARRIER, Rear Bearing	<b>Items Not Illustrated:</b>			
26	74908	4	TAPTITE, M5-0.8 x 10	B2649	1	Generator Owner's Manual	
27	86308B	4	BOLT, M6-1 x 165mm Stator	A8927	1	Engine Owner's Manual	
28	65795	2	RECTIFIER, Battery Charge	37806	1	125V 30A Locking plug	
29	66849C	1	TAPTITE, M5-0.8 x 30	43438	1	240V 30A Locking plug	
30	67022	1	GROMMET, Rubber	72347	1	Spark plug	
31	84132	1	ASSEMBLY, Power Regulator	73111	1	Air cleaner element	
32	66386	1	ASSEMBLY, Brush Holder	84882	1	Spark plug wrench	
33	66849	2	TAPTITE, M5-0.8 x 16	65787	1	Battery charge cable	
34	B4871	1	COVER, Bearing Carrier	<b>Battery Tray Components:</b>			
35	22769	1	WASHER, #10 Int. Shakeproof	22129	2	Lockwasher, M8	
36	86494	1	SCREW, M6-1.0 x 16 Wing	45771	2	Hex nut M8	
37	86292	9	SCREW, #10 Self Drilling	96925	1	Battery tiedown	
38	77395	4	NUT, M6 Flange Lock	96924	2	J-bolt	
39	83465	4	GROMMET, Tank	15453621	1	Battery cable, positive	
40	78831B	4	HHCS, M6-1.0 x 60, SEMS	15553621	1	Battery cable, negative	
41	80270	1	VALVE, Tank	96923	1	Battery tray	
42	78299	1	BUSHING, Plastic Tank	22145	2	Flat washer	
43	B4363	1	CAP, Fuel Gauge	58443	4	Screws, battery tray	
44	B1998	1	TANK, Fuel 7 Gal Assy. (Includes 41 & 42)	<b>Optional Accessories Not Included:</b>			
45	B92039	1	SHIELD, Heat	84883		Cord Wrap	

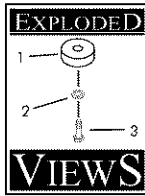

## EXPLODED VIEW AND PARTS LIST – CONTROL PANEL

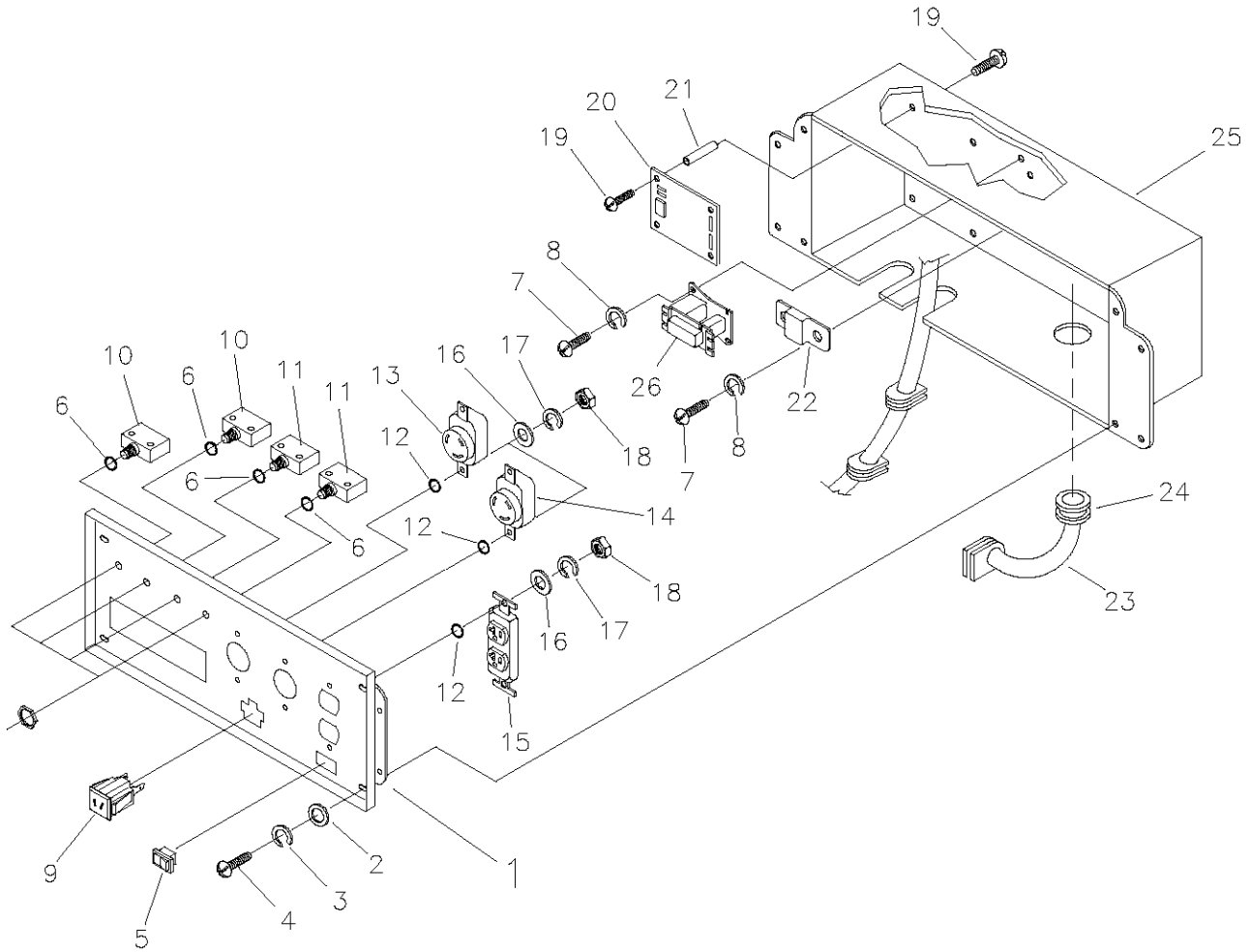

Item	Part #	Qty	Description	Item	Part #	Qty	Description
1	A92070	1	PANEL, Control	14	43437	1	OUTLET, 120V/240V, 30A Locking
2	23897	4	FLAT WASHER, #10 M5	15	68759	1	OUTLET, 120V, 20A Duplex
3	49226	4	LOCK WASHER, M5	16	43180	6	FLAT WASHER, M4
4	91526	4	SCREW, M5-0.8 x 12mm	17	22264	6	LOCK WASHER, #8 M4
5	82538	1	SWITCH, Idle Control	18	51715	6	NUT, M4-0.7 Hex
6	82881	4	LOCK WASHER, 7/16"	19	64526	8	SCREW, #6-32 x 3/8"
7	43181	4	SCREW, M3 - 0.5 x 10mm	20	83970	1	BOARD, System Control
8	43182	4	LOCK WASHER, M3	21	64525	4	STAND-OFF, 3/4" Hex
9	90418	1	OUTLET, 12V	22	87962	1	CIRCUIT BREAKER, 12V, 10A
10	75207A	2	CIRCUIT BREAKER, 30A	23	84335	1	ASSEMBLY, Wire Harness
11	75207	2	CIRCUIT BREAKER, 20A	24	84134	1	GROMMET, Rubber Conn.
12	23365	6	WASHER, #8 Shakeproof	25	B92069	1	BOX, Control Panel
13	68868	1	OUTLET, 120 Volt, 30A Locking	26	84028	1	TRANSFORMER, Idle Control



# PORTABLE GENERATOR LIMITED WARRANTY

GENERAC PORTABLE PRODUCTS (hereafter referred to as the COMPANY) warrants to the original purchaser that the components in its portable generator will be free from defects in materials or workmanship for the items and period set forth below from the date of original purchase. This warranty does not include the gasoline engine when furnished or attached because such engine is covered solely by the engine manufacturer's warranty. Starting batteries are not warranted by the COMPANY. The term "original purchaser" means the person for whom the generator is originally purchased. This warranty is not transferable and applies only to portable generators driven by an overhead valve engine.

## Warranty Schedule:

	Consumer*	Commercial*
Engine	Warranted solely by the engine manufacturer	
All other parts	2 years (2nd year parts only)	1 Year

*With the exception of European Community Countries, all units bound for export shall be warranted for One (1) Year in Consumer applications, and 90 days in Commercial applications as defined below.*

**\*NOTE: For the purpose of this warranty "consumer use" means personal residential household use by original purchaser. This warranty does not apply to units used for Prime Power in place of utility. "Commercial Use" means all other uses, including rental, construction, commercial and income producing purposes. Once a generator has experienced commercial use, it shall thereafter be considered a commercial use generator for the purposes of this warranty.**

During said warranty period, the COMPANY will, at its option, repair or replace any part which, upon examination by the COMPANY, is found to be defective under normal use and service\*\*. All transportation costs under warranty, including return to the factory if necessary, are to be borne by the purchaser and prepaid by the purchaser. This warranty does not cover normal maintenance and service and does not apply to a generator set, alternator, or parts which have been subjected to improper or unauthorized installation or alteration, misuse, negligence, accident, overloading, overspeeding, improper maintenance, repair or storage so as, in the COMPANY's judgement, to adversely affect its performance and reliability.

**\*\*NORMAL WEAR: As with all mechanical devices, the generator needs periodic parts service and replacement to perform well. This warranty will not cover repair when normal use has exhausted the life of a part or generator.**

THERE IS NO OTHER EXPRESS WARRANTY. THE COMPANY HEREBY DISCLAIMS ANY AND ALL IMPLIED WARRANTIES, INCLUDING BUT NOT LIMITED TO THOSE OF MERCHANTABILITY AND FITNESS FOR A PARTICULAR PURPOSE TO THE EXTENT PERMITTED BY LAW. THE DURATION OF ANY IMPLIED WARRANTIES WHICH CANNOT BE DISCLAIMED IS LIMITED TO THE TIME PERIOD AS SPECIFIED IN THE EXPRESS WARRANTY. LIABILITY FOR CONSEQUENTIAL, INCIDENTAL OR SPECIAL DAMAGES UNDER ANY AND ALL WARRANTIES IS EXCLUDED. THE COMPANY ALSO DISCLAIMS ANY RESPONSIBILITY FOR INCIDENTAL OR CONSEQUENTIAL DAMAGES, SUCH AS THE LOSS OF TIME OR THE USE OF THE POWER EQUIPMENT, OR ANY COMMERCIAL LOSS DUE TO THE FAILURE OF THE EQUIPMENT. AND ANY IMPLIED WARRANTIES ARE LIMITED TO THE DURATION OF THIS WRITTEN WARRANTY.

Some states do not allow limitations on how long an implied warranty lasts, or the exclusion or limitation of incidental or consequential damages, so the above limitations or exclusions may not apply to you. This warranty gives you specific legal rights and you may also have other rights, which vary from state to state.

For service, see your nearest COMPANY authorized warranty service facility or call 1-877-544-0982. Or look on the internet at [www.generac-portables.com](http://www.generac-portables.com). Warranty service can be performed only by a COMPANY authorized service facility. This warranty will not apply to service at any other facility. At the time of requesting warranty service, evidence of original purchase date must be presented.

**GENERAC PORTABLE PRODUCTS**  
Jefferson, Wisconsin U.S.A.