

GENERAC 4000XL

Extended Life Generator

Owner's Manual

Operating and Maintenance Instructions

Danger: this generator is designed for outdoor use only. Do not use this generator inside any building or enclosure including the generator compartment of a recreational vehicle (RV). Fire or an explosion may result. No user performed modifications, including venting of exhaust and/or cooling ventilation, will eliminate the danger. Also, allow at least two feet of clearance on all sides of the generator even while operating the unit outdoors.

Danger: if this unit is used for backup power in the event of a utility power failure, the following step must be taken: Before connecting the generator to an electrical system, open the main circuit breaker or main switch serving the system, to isolate the generator system from the electric utility. Failure to isolate the generator and utility systems may result in damage to the generator and may also result in injury or death to electric utility workers, due to a back-feed of electrical energy.

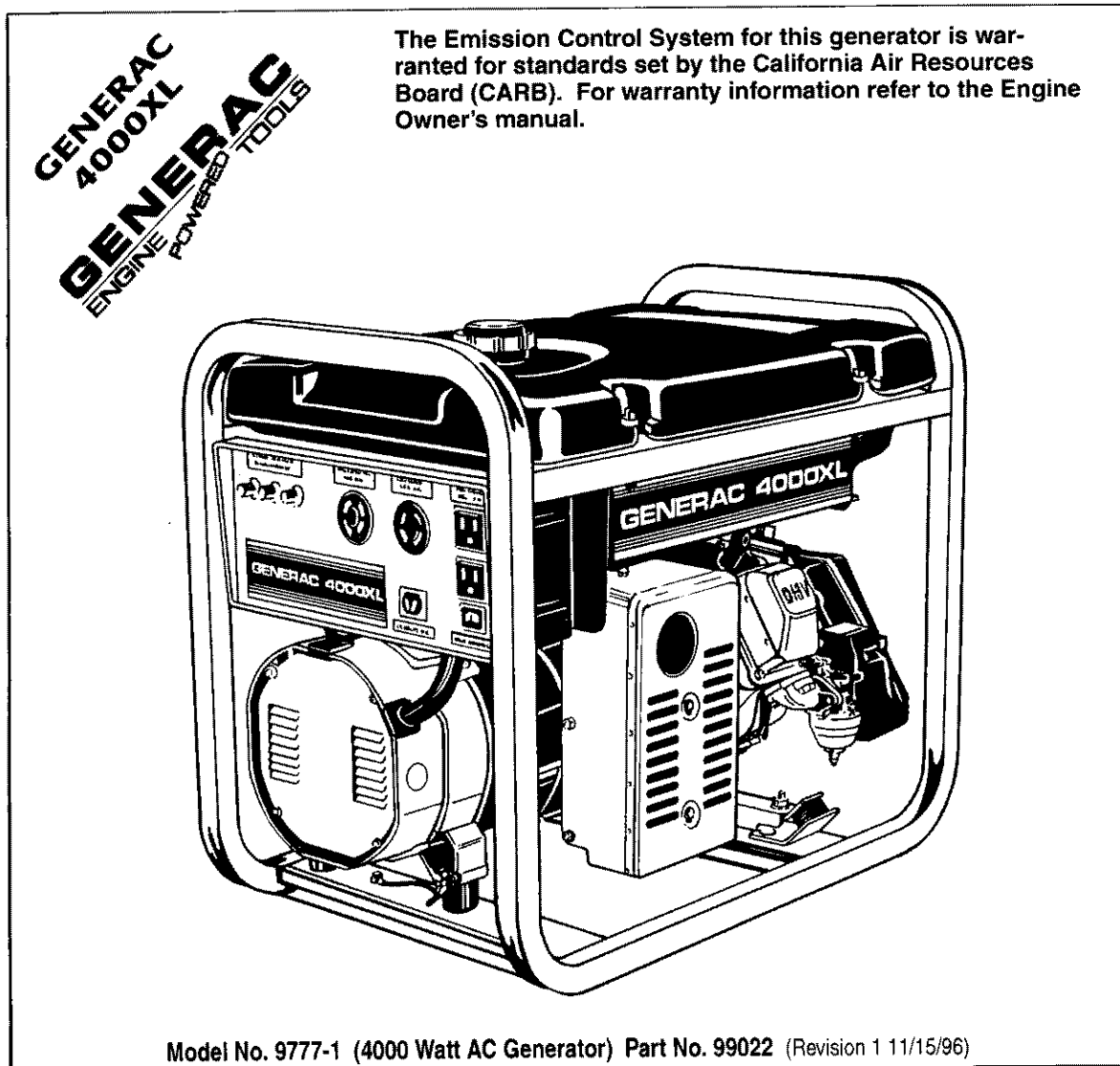

THIS SYMBOL POINTS OUT IMPORTANT SAFETY INSTRUCTIONS, WHICH, IF NOT FOLLOWED, COULD ENDANGER THE PERSONAL SAFETY AND/OR PROPERTY OF YOURSELF AND OTHERS. READ AND FOLLOW ALL INSTRUCTIONS IN THE MANUAL BEFORE ATTEMPTING TO OPERATE THIS UNIT.



EQUIPMENT DESCRIPTION

This generator is an engine-driven, revolving field, alternating current (AC) generator. It was designed to supply electrical power for operating compatible electrical lighting, appliance, tool and motor loads. This manual contains information for a generator that operates 120 and/or 240 volts, single phase, 60Hz devices that require up to 4000 watts (4.0 kW) of power that pull up to 33.3 amps at 120 volts or 16.7 amps at 240 volts.



CAUTION: Do not exceed the generator's wattage/ampere capacity. Add up the rated watts of all devices you are connecting to generator receptacles at one time. This total should not be greater than 4000 watts for this generator. In most cases rated watts of the electrical device can be found on the device nameplate. If the device nameplate gives only volts and amps, multiply volts times amps to obtain watts (volts x amps = watts).

The generator's revolving field is driven at about 3600 rpm by a single-cylinder engine.

Every effort has been expended to make sure that the information in this manual is both accurate and current. However, Generac reserves the right to change, alter or otherwise improve the product at any time without prior notice.



DANGER: Do not tamper with engine governed speed. High operating speeds are dangerous and increase risk of personal injury or damage to equipment. The generator supplies correct rated frequency and voltage only when running at proper governed speed. Incorrect frequency and/or voltage can damage some connected electrical loads. Operating at excessively low speeds imposes a heavy load at such reduced speeds, when adequate engine power is not available, and may short engine life.

MODEL & SERIAL NUMBERS

In the spaces provided below, insert the Model and Serial numbers of your generator. Retain these numbers for future reference. You can find Model and Serial numbers on the generator data plate, along with other important information.

Model Number _____

Serial Number _____



WARNING:



The engine exhaust from this product contains chemicals known to the State of California to cause cancer, birth defects, or other reproductive harm.

SAFETY RULES

This generator set was designed and manufactured for specific applications. Do not attempt to modify the unit or use it for any application it was not designed for. If you have any questions about your generator's application, ask your Dealer/Distributor or consult the factory.

The manufacturer could not possibly anticipate every circumstance that might involve a hazard. For that reason warnings in the Manual and warnings on tags or decals affixed to the unit are not all-inclusive. If you intend to handle, operate or service the unit by a procedure or method not specifically recommended by the manufacturer, first make sure that such a procedure or method will not render this equipment unsafe or pose a threat to you and others.

Read this manual carefully and become familiar with your generator set. Know its applications, its limitations and any hazards involved.

- The generator produces a very powerful voltage that can cause extremely dangerous electrical shock. Avoid contact with bare wires, terminals, etc. Never permit any unqualified person to operate or service the generator.
- Never handle any kind of electrical cord or device while standing in water, while barefoot or while hands or feet are wet. Dangerous electrical shock will result.
- The National Electric Code requires the frame and external electrically conductive parts of generator be properly connected to an approved earth ground. Local electrical codes may also require proper grounding of the generator. Consult with a local electrician for grounding requirements in your area.
- Use a ground fault circuit interrupter in any damp or highly conductive area (such as metal decking or steel work).
- Do not use any worn, bare, frayed or otherwise damaged electrical cord sets with the generator. Using any defective cord set may result in electrical shock or damage to equipment and/or property.
- Operate generator only on level surfaces and where it will not be exposed to excessive moisture, dirt, dust or corrosive vapors.



- Gasoline is highly **FLAMMABLE** and its vapors are **EXPLOSIVE**. Do not permit smoking, open flames, sparks or heat in the vicinity while handling gasoline. Avoid spilling gasoline on a hot engine. Comply with all laws regulating storage and handling of gasoline.
- Do not overfill the fuel tank. Always allow room for fuel expansion. If tank is overfilled, fuel can overflow onto a hot engine and cause **FIRE** or an **EXPLOSION**.
- Never store generator with fuel in tank where gasoline vapors might reach an open flame or spark or pilot light (as on a furnace, water heater or clothes dryer). **FIRE** or an **EXPLOSION** might result.
- Generator exhaust gases contain **DEADLY** carbon monoxide gas. This dangerous gas, if breathed in sufficient concentrations, can cause unconsciousness or even death. Operate this equipment only in the open air where adequate ventilation is available.
- The engine-generator requires an adequate flow of cooling air for its continued proper operation. Never operate the unit inside any room or enclosure where the free flow of cooling air into and out of the unit might be obstructed. Without sufficient cooling air flow, the unit quickly overheats, damaging the generator or nearby property.
- Allow at least 2 feet of clearance on all sides of generator, even while operating unit outdoors, or you could damage the unit.
- Never start, or stop, the engine-generator with electrical loads connected to receptacles with the connected devices turned **ON**. Start the engine and let it stabilize before connecting electrical loads. Disconnect all electrical loads before shutting down the generator.
- Do not insert any object through cooling slots of the engine-generator. You could damage the unit or injure yourself.
- Never operate generator (a) in rain; (b) in any enclosed compartment; (c) if engine speed changes; (d) if connected electrical devices overheat; (e) if electrical output is lost; (f) if engine or generator sparks; (g) if flame or smoke is observed while unit is running; (h) if unit vibrates excessively.

GROUNDING THE GENERATOR

The National Electric Code requires the frame and external electrically conductive parts of generator be properly connected to approved earth ground. Local electrical codes may also require proper grounding of the unit. For that purpose, a **GROUNDING WING SCREW** (Figure 1) is provided on the cradle frame.

Figure 1 — Location of Grounding Wing Nut

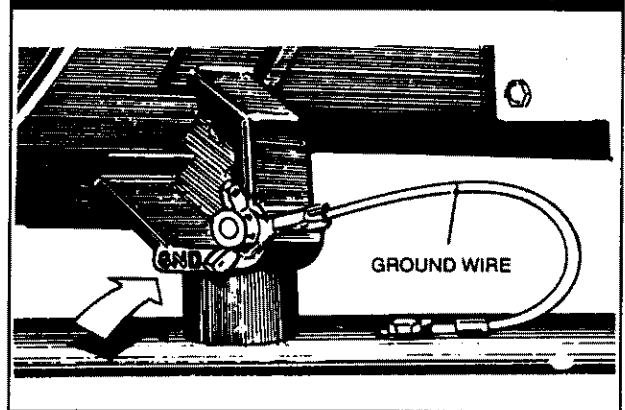

Generally, connecting a No. 12 AWG (American Wire Gauge) stranded copper wire to the grounding wing screw and to an earth-driven copper or brass grounding rod (electrode) provides adequate protection against electrical shock. However, local codes may vary widely. Consult with a local electrician for grounding requirements in your area. Be sure to keep the ground wire attached while you connect the electrode.

Properly grounding the generator helps prevent electrical shock if a ground fault conditions exists in the generator or in connected electrical devices. Proper grounding also helps dissipate static electricity, which often builds up in ungrounded devices.

BEFORE STARTING THE ENGINE

Perform the following tasks before trying to start the generator engine:

■ ADD ENGINE OIL BEFORE INITIAL START

Remove one of the yellow Oil Fill Caps (Figure 2 on page 4) and add engine oil until oil level is at point of overflowing. Check engine oil level before starting each time thereafter. If oil level is below point of overflowing, fill to proper level.



Figure 2 — Oil Fill Cap

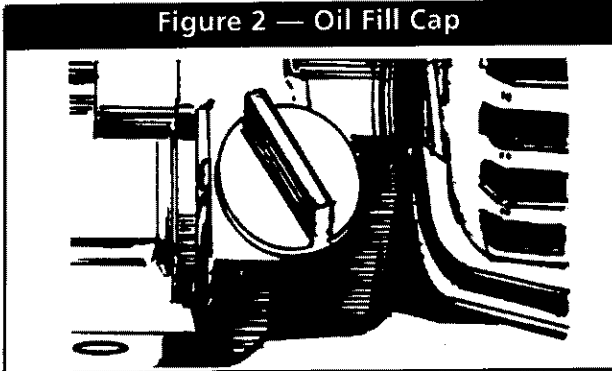

CAUTION: Any attempt to crank or start the engine before it has been properly serviced with the recommended oil results in an engine failure.

The recommended oils include the following:

- During summer months: SAE 10W-30
- During winter months: SAE 5W-20 or 5W-30. DO NOT USE SAE 10W-40.

Crankcase oil capacity is about 620ml or about 21 fluid ounces with the oil filter. Without the filter to capacity is 870ml (29.5 oz.). Use no special additives.

NOTE: The generator's revolving field rides on a pre-lubricated and sealed ball bearing that requires no additional lubrication for the life of the bearing.

■ ADD FUEL

Use regular UNLEADED gasoline with the generator engine. Regular leaded gasoline may also be used if UNLEADED is not available. Fuel tank capacity is 4 U.S. gallons.

CAUTION: Do not overfill the fuel tank. Always allow room for fuel expansion.

OPERATING THE GENERATOR

■ STARTING THE ENGINE

- Disconnect all electrical loads from the generator.
- Open the fuel shut-off valve.
- Refer to the engine manual.

■ APPLYING ELECTRICAL LOADS

- Let engine stabilize and warm up for about five minutes after starting.
- Plug in and turn on the desired 120 or 240 volts, single phase, 60 Hertz, AC electrical loads. **DO NOT OVERLOAD THE GENERATOR.** Add up the rated watts (or amps) of all loads to be connected at one time. This total should not be greater than the rated wattage/ampere capacity of the generator.

■ STOPPING THE ENGINE

Disconnect all electrical loads and let engine run at no-load for about five minutes, then turn off the engine by moving the Run/Stop switch to STOP position. See engine manual Close fuel shut-off valve.

OPERATING AUTOMATIC IDLE CONTROL

An Automatic Idle Control system provides greatly improved fuel economy by operating the unit at its normal high governed speed only when electrical loads are plugged in and turned ON. The system consists of (a) an Idle Control Circuit Board, (b) a Sensing Transformer, (c) an Electromagnet, and (d) an Idle Control Switch located on the control panel.

Engine-generator runs at high governed speed with Idle Control Switch ON(-) only when an electrical load is connected to the generator and turned on. When the electrical load is disconnected, an Electromagnet is energized to pull the engine throttle control against its idle stop. Engine then runs at reduced (idle) speed.

The Electromagnet cannot be energized with Idle Control Switch OFF, since its power circuit is open. Engine runs at high governed speed (about 3600 rpm) whether load(s) are connected or not.

■ ADJUSTING IDLE CONTROL

You can adjust and set the Idle Control on the engine-generator as follows:

- With unit running and warmed up, turn the idle control bolt clockwise (faster speed), or counterclockwise (slower speed) until the engine speed is between 40 and 45 Hz. (2400 ~ 2700 rpm). See Figure 3.

Figure 3 — Adjusting Idle Control

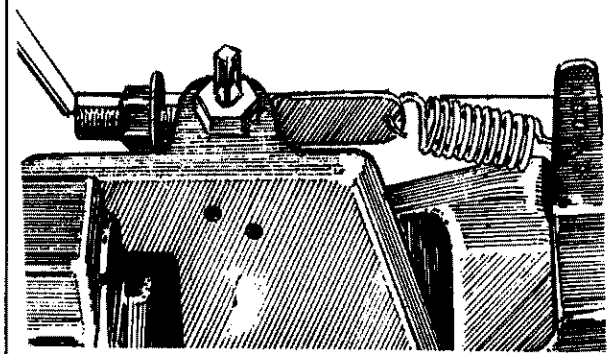

- Lock the Idle Control Jam Nut against the idle control bracket, while making certain the engine speed is still within the range of 40 to 45 Hz.

NOTE: Engine idle speeds of less than 40 Hz could cause the engine to stall if you apply sudden block loads.

■ BATTERY SAFETY



WARNING: STORAGE BATTERIES GIVE OFF EXPLOSIVE HYDROGEN GAS WHILE CHARGING. AN EXPLOSIVE MIXTURE WILL REMAIN AROUND BATTERY FOR A LONG TIME AFTER IT HAS BEEN CHARGED. THE SLIGHTEST SPARK CAN IGNITE GAS AND CAUSE AN EXPLOSION. SUCH AN EXPLOSION CAN SHATTER BATTERY AND CAUSE BLINDNESS OR OTHER SERIOUS INJURY.



WARNING: DO NOT PERMIT SMOKING, OPEN FLAME, SPARKS OR ANY OTHER SOURCE OF HEAT AROUND A BATTERY. DO NOT USE A LIGHTER OR OTHER FLAME FOR CHECKING BATTERY FLUID LEVELS. WEAR PROTECTIVE GOGGLES, RUBBER APRON AND RUBBER GLOVES WHEN WORKING AROUND A BATTERY. BATTERY ELECTROLYTE FLUID IS AN EXTREMELY CAUSTIC SULFURIC ACID SOLUTION THAT CAN CAUSE SEVERE BURNS. DO NOT PERMIT FLUID CONTACT WITH EYES, SKIN, CLOTHING, ETC. IF SPILL OCCURS, FLUSH AREA WITH CLEAR WATER IMMEDIATELY.

■ CHARGING A BATTERY

Your generator has the capability of recharging a discharged 12-volt automotive or utility style storage battery. Do not use the unit to charge any 6-volt batteries. Do not use the unit to crank an engine having a discharged battery. To recharge 12-volt batteries, proceed as follows:

- Check fluid level in all battery cells. If necessary, add **ONLY** distilled water to cover separators in battery cells. **DO NOT USE TAP WATER.**
- If the battery is equipped with vent caps, make sure they are installed and are tight.
- If necessary, clean battery posts or terminals.
- Connect battery charge cable connector plug to panel receptacle identified by the words "12-VOLT D.C. (Figure 4).

Figure 4 — Connect Battery Cable

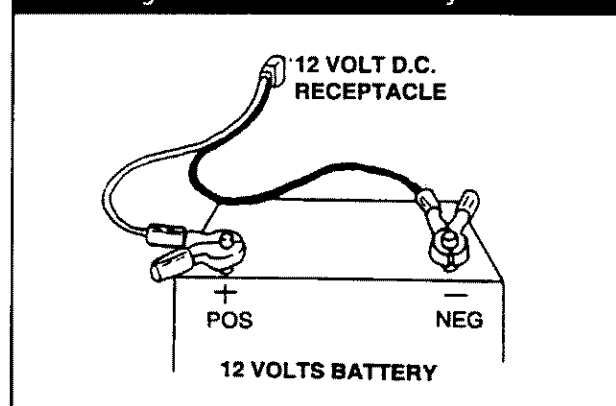

- Connect battery charge cable clamp with red handle to battery post or terminal indicated by a POSITIVE, POS or (+).
- Connect battery charge cable clamp with black handle to battery post or terminal indicated by a NEGATIVE, NEG, or (-).
- Start engine (see "Starting the Engine" on Page 4). Let the engine run while battery recharges.
- When battery has charged, shut down engine (see "Stopping the Engine" on Page 4).

NOTE: Use an automotive hydrometer to test battery state of charge and condition. Follow the hydrometer manufacturer's instructions carefully. Generally, a battery is considered to be at 100% state of charge when specific gravity of its fluid (as measured by hydrometer) is 1.260.

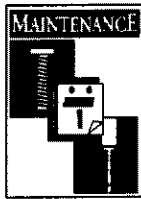

CORD SETS FOR RECEPTACLES

This generator is equipped with the following receptacles:

■ TWO 120-VOLT, 15 AMP RECEPTACLES

Each receptacle is protected against overload by a 15-amp push-to-reset type f circuit breaker. Use each receptacle to operate 120 volts, single phase 60 Hz, AC electrical loads requiring up to 1800 watts (1.8 kW) at 15 amps of current. Use cord sets that are rated 125 volts at 15 amps (or greater).

Figure 5 — 120 Volt, 15 Amp Receptacles

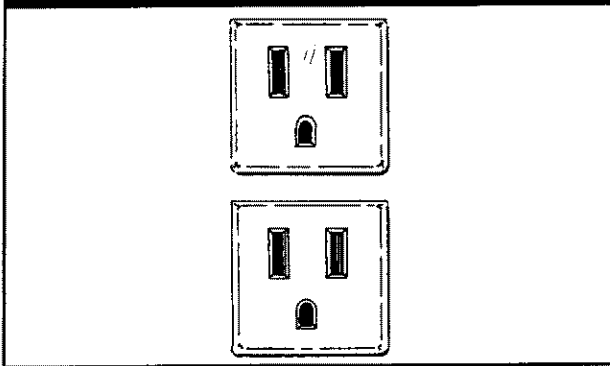

■ 120-VOLT, 30 AMP LOCKING TYPE RECEPTACLE

Use NEMA L5-30P type plug with this receptacle. Generac provides a plug as part of the optional accessories that go with the 4000 XL (Part # 84894). Connect a 3-wire cord set rated 125 volts at 30 AC amps to the plug according to Figure 6. Use this receptacle to operate 120 volts AC, 60 Hz, single phase loads requiring up to 4000 watts (4.0 kW) of power at 30 AC amps. The outlet is protected by a 30 amp push-to-reset circuit breaker.

Figure 6 — 120 Volt, 30 Amp Receptacle

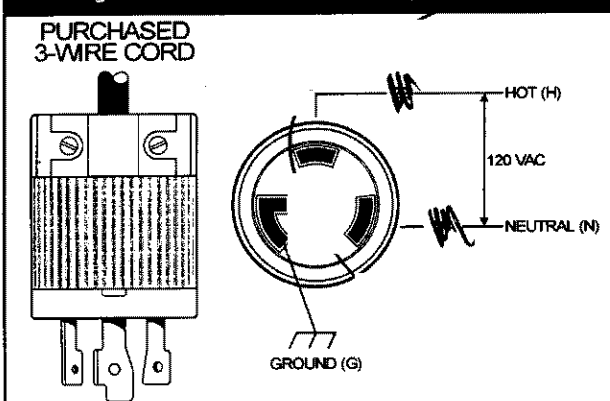

■ 120/240 VOLT, 20 AMP LOCKING TYPE RECEPTACLE

Use NEMA L14-30P type plug with this receptacle. You can order one from Generac (Part # 84893). Connect a 4-wire cord set rated 250 volts at 20 AC amps (or greater) according to Figure 7. You can use the same 4-wire cord if the you plan only to run a 120 volts load. This receptacle powers 120/240 volts AC, 60 Hz, single phase loads requiring up to 4000 watts of power (4.0 kW) at 33.3 AC amps for 120 volts; and 16.7 AC amps for 240 volts. Outlet is protected by a 20 amp push-to-reset circuit breaker.

Figure 7 — 120/240V, 20A Receptacle

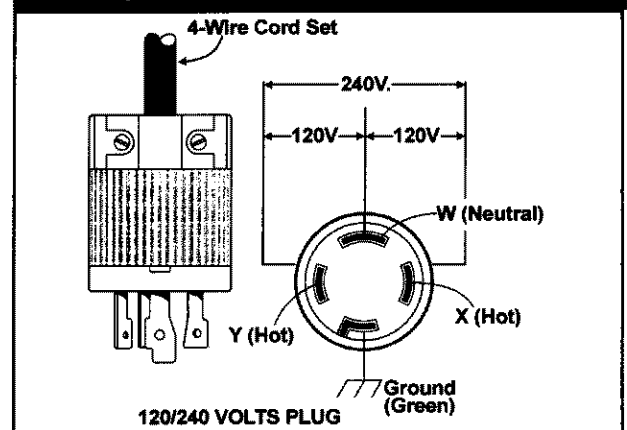

■ RESTARTING

If you try to restart the engine within 5 seconds after it shuts down, the engine may NOT start. The system needs 5 to 10 seconds to reset.

NOTE: If you do restart engine after such a shutdown and have not corrected the low oil pressure, the engine runs for about 10 seconds as described above and then stops.

GENERAL MAINTENANCE RECOMMENDATIONS

The Owner/Operator is responsible for making sure that all periodic maintenance tasks are completed on a timely basis; that all discrepancies are corrected; and that the unit is kept clean and properly stored. Never operate a damaged or defective generator.

■ ENGINE MAINTENANCE

See engine manual for instructions.

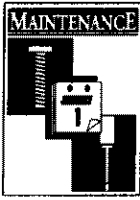

■ GENERATOR MAINTENANCE

Generator maintenance consists of keeping the unit clean and dry. Operate and store the unit in a clean dry environment where it will not be exposed to excessive dust, dirt, moisture or any corrosive vapors. Cooling air slots in the generator must not become clogged with snow, leaves or any other foreign material.

Check the cleanliness of the generator frequently and clean when dust, dirt, oil, moisture or other foreign substances are visible on its exterior surface.

NOTE: We DO NOT recommend using a garden hose to clean generator. Water can enter engine fuel system and cause problems. In addition, if water enters generator through cooling air slots, some of the water will be retained in voids and cracks of the rotor and stator winding insulation. Water and dirt buildup on the generator internal windings will eventually decrease the insulation resistance of these windings.

■ TO CLEAN THE GENERATOR

- Use a damp cloth to wipe exterior surfaces clean.
- Soft, bristle brush may be used to loosen caked on dirt or oil.
- A vacuum cleaner may be used to pick up loose dirt and debris.
- Low pressure air (not to exceed 25 psi) may be used to blow away dirt. Inspect cooling air slots and opening on generator. These openings must be kept clean and unobstructed.

SERVICE AND ADJUSTMENTS

Refer to engine manual for information.

STORAGE INSTRUCTIONS

The generator should be started at least once every seven days and allowed to run at least 30 minutes. If this cannot be done and you must store the unit for more than 30 days, use the following guidelines to prepare it for storage.

■ GENERATOR

- Clean the generator as outlined in "To Clean the Generator".
- Check that cooling air slots and openings on generator are open and unobstructed.



DANGER: THE STORAGE COVER (Part No. 84895) IS FLAMMABLE. DO NOT PLACE THE STORAGE COVER OVER A HOT GENERATOR. LET THE UNIT COOL FOR A SUFFICIENT TIME BEFORE PLACING THE COVER ON THE UNIT. IF YOU PLACE THE COVER ON THE UNIT BEFORE GENERATOR IS SUFFICIENTLY COOL, THE COVER COULD START ON FIRE.

■ OTHER STORAGE TIPS

- Do not store gasoline from one season to another.
- Replace your gasoline can if it starts to rust. Rust and/or dirt in a gasoline can cause problems when you use that fuel with this unit.
- Store in clean and dry area.

SPECIFICATIONS

GENERATOR

Rated Maximum Continuous	
AC Power Output.....	4000 watts (4.0 kW)
Rated Voltage	120/240 Volts
Rated Maximum Current at 240 Volts.....	16.7 AC amperes
Rated Maximum Current at 120 Volts.....	33.3 AC amperes
Phase.....	1
Rated AC Frequency	60 Hertz
Number of Rotor Poles.....	1
Driven Speed of Rotor.....	3600 rpm

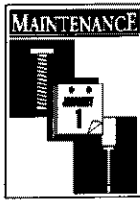

ACCESSORIES

- Wheel Kit (order Part No. 93580); Fuel Gauge (order #84995)
- Service Kit [includes air cleaner, spark plug, wrench, screw driver] (order #84684); Storage Cover (order #84895)
- Outlet Extension Plug, 125 volts, 30 amp (order #84894); Outlet Extension Plug, 125/250 volts, 20 amp (order #84893); Extension Cord Mounting Brackets (order #84883)
- Optional Oil Filter Kit [includes oil filter, oil filter adaptor, coil filter pad gasket and fasteners (order #93637)

DON'T OVERLOAD THE GENERATOR

Overloading a generator in excess of its rated wattage capacity can result in damage to generator and to connected electrical devices. Observe the following, to prevent overloading the unit:

- Add up the total wattage of all electrical devices to be connected at one time. This total should NOT be greater than the generator's wattage capacity.

- The rated wattage of lights can be taken from light bulbs. The rated wattage of tools, appliances and motors can usually be found on a data plate or decal affixed to the device.
- If the appliance, tool or motor does not give wattage, multiply 120 volts times ampere rating to determine watts (volts x amps = watts).
- Some electric motors, such as induction types, require about two-and-a-half times more watts of power for starting than for running. This surge of power lasts for only a few seconds when starting such motors. Be sure you allow for this high starting wattage when selecting electrical devices to connect to your generator. First figure the watts needed to start the largest motor. Add to that figure the running watts of all other connected loads.
- Items in the guide below are provided to help you to determine how many items the generator can operate at one time.

WATTAGE REFERENCE GUIDE

	RUNNING WATTS		RUNNING WATTS
*Air Conditioner (12,000 Btu)	1700	Impact Wrench	500
Battery Charger (20 amp)	500	*Jet Pump	800
Belt Sander (3")	1000	Lawn Mower	1200
Chain Saw	1200	Light Bulb	100
Circular Saw (6-12")	800 to 1000	Microwave Oven	700
Coffee Maker	1000	*Milk Cooler	1100
*Compressor (1 HP)	2000	Oil Burner on Furnace	300
*Compressor (3/4 HP)	1800	Oil Fired Space Heater (140,000 Btu)	400
*Compressor (1/2 HP)	1400	Oil Fired Space Heater (85,000 Btu)	225
Curling Iron	700	Oil Fired Space Heater (30,000 Btu)	150
*Freezer	500	*Paint Sprayer, Airless (1/3 HP)	600
Disc Sander (9")	1200	Paint Sprayer, Airless (handheld)	150
Edge Trimmer	500	Radio	50 to 200
Electric Nail Gun	1200	*Refrigerator	600
Electric Range (one element)	1500	Slow Cooker	200
Electric Skillet	1250	*Submersible Pump (1-1/2 HP)	2800
*Furnace Fan (1/3 HP)	1200	*Submersible Pump (1 HP)	2000
Hair Dryer	1200	*Submersible Pump (1/2 HP)	1500
Hand Drill (1")	1100	Sump Pump	600
Hand Drill (1/2")	750 to 1000	*Table Saw (10")	1750 to 2000
Hand Drill (3/8")	500	Television	200 to 500
Hand Drill (1/4")	250	Weed Trimmer	500
Hedge Trimmer	450		

* Allow 2-1/2 times the listed watts for starting these devices.



TROUBLESHOOTING POINTS

PROBLEM

CAUSE

CORRECTION

Engine is running, but no AC output is available.

1. One of the circuit breakers is open.
2. Fault in generator.
3. Poor connection or defective cord set.
4. Connected device is bad.

1. Reset circuit breaker.
2. Contact Generac Service Facility.
3. Check and repair.
4. Connect another device that is in good condition.

Engine runs good at no-load but "bogs down" when loads are connected

1. Short circuit in a connected load.
2. Engine speed is too slow.
3. Generator is overloaded.
4. Shorted generator circuit.

1. Disconnect shorted electrical load.
2. Contact Generac Service Facility.
3. See "Don't Overload the Generator"
4. Contact Generac Service Facility.

Engine will not start; or starts and runs rough.

1. Run/Stop Switch set to STOP.
2. Dirty air cleaner
3. Out of gasoline.
4. Stale gasoline.
5. Spark plug wire not connected to spark plug.
6. Bad spark plug.
7. Water in gasoline.
8. Overchoking.
9. Excessively rich fuel mixture.
10. Intake valve stuck open or closed.
11. Engine has lost compression.
12. Intake valve stuck open or closed.
13. Engine compression lost.
14. Failed battery.

1. Set switch to RUN.
2. Clean or replace air cleaner.
3. Fill fuel tank.
4. Drain gas tank; fill with fresh fuel.
5. Connect wire to spark plug.
6. Replace spark plug.
7. Drain gas tank; fill with fresh fuel.
8. Open choke fully and crank engine.
9. Contact Generac Service Facility.
10. Contact Generac Service Facility.
11. Contact Generac Service Facility.
12. Contact Generac Service Facility.
13. Contact Generac Service Facility.
14. Replace battery.

Engine shuts down during operation

1. Out of gasoline.
2. Low oil level.

1. Fill fuel tank.
2. Fill crankcase to proper level.

Engine lacks power.

1. Load is too high.
2. Dirty air filter.

1. See "Don't Overload the Generator"
2. Replace air filter.

Engine "hunts" or falters.

1. Choke is opened too soon.
2. Carburetor is running too rich or too lean.

1. Move choke to halfway position until engine runs smoothly.
2. Contact Generac Service Facility.



ELECTRICAL DATA

SCHEMATIC

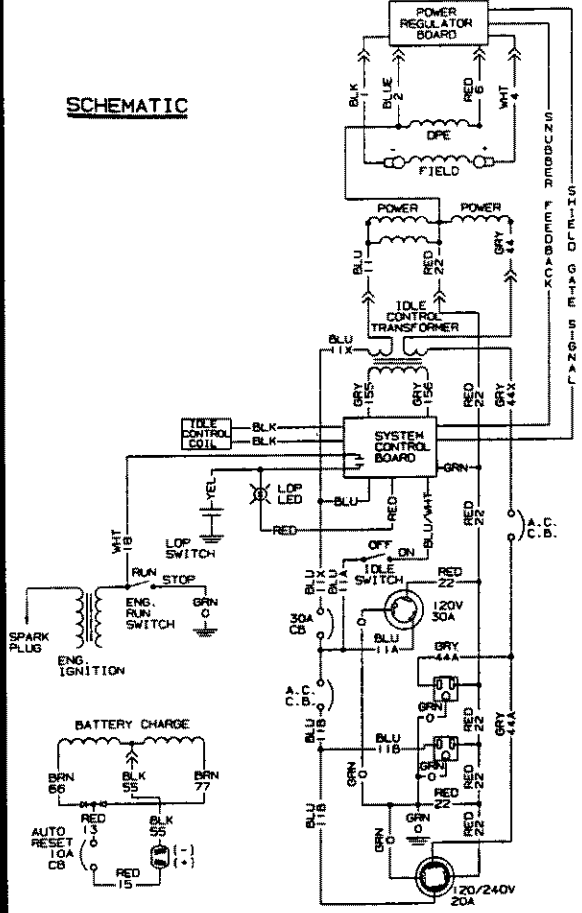

WIRING DIAGRAM

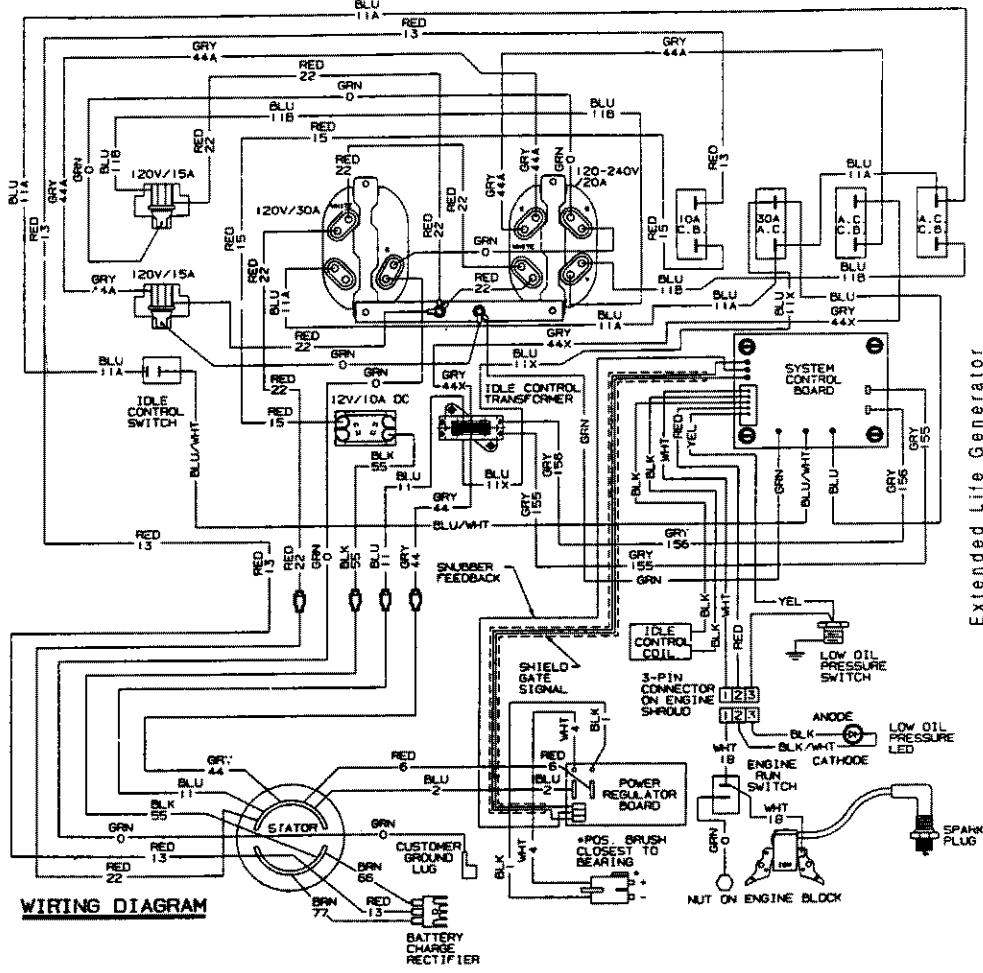

Extended Life Generator

EXPLODED VIEW — CONTROL PANEL

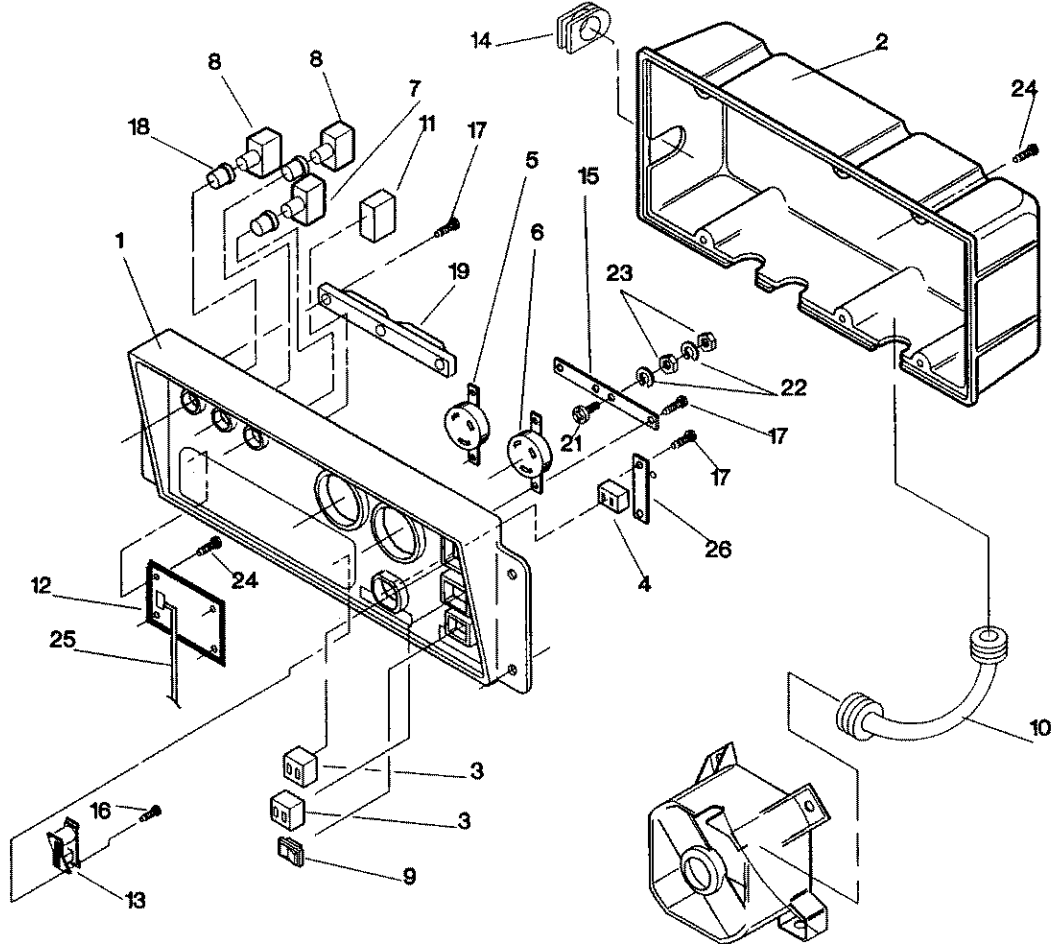

ITEM	PART NO.	QTY.	DESCRIPTION	ITEM	DESCRIPTION	PART NO.	QTY.
1	83976	1	Control Panel	13	84028	1	Idle Control Transformer
2	83975	1	Control Box	14	67022	1	Rubber Grommet
3	66818	2	120 Volts AC Outlet	15	85584	1	Bus Bar
4	66821	1	12 Volts DC Outlet	16	84543A	2	3.0 x 12mm Screw
5	68867C	1	120/240 volts, 20 amp Locking Type Outlet	17	84543C	4	3.5 x 18mm Screw
6	68868C	1	120 volts, 30 amp Locking Type Outlet	18	84198	3	Circuit Breaker Shield
7	75207A	1	30 amp Circuit Breaker	19	84197	1	Circuit Brker Retaining Bar
8	75207G	2	18 amp Circuit Breaker	21	75476	2	4.0 x 16mm Screw
9	82538	1	On/Off Rocker Switch	22	22264	4	M4 Lock Washer
10	84134	1	Rubber Grommet	23	51715	8	M3 Hex Nut
11	83514	1	10 amp Circuit Breaker	24	84543B	10	3.5 x 12mm Screw
12	83970	1	System Control Board	25	84335	1	Wire Harness
				26	82542	1	DC Outlet Retaining Bar

EXPLODED VIEW — GENERATOR

Drawing No. 99029

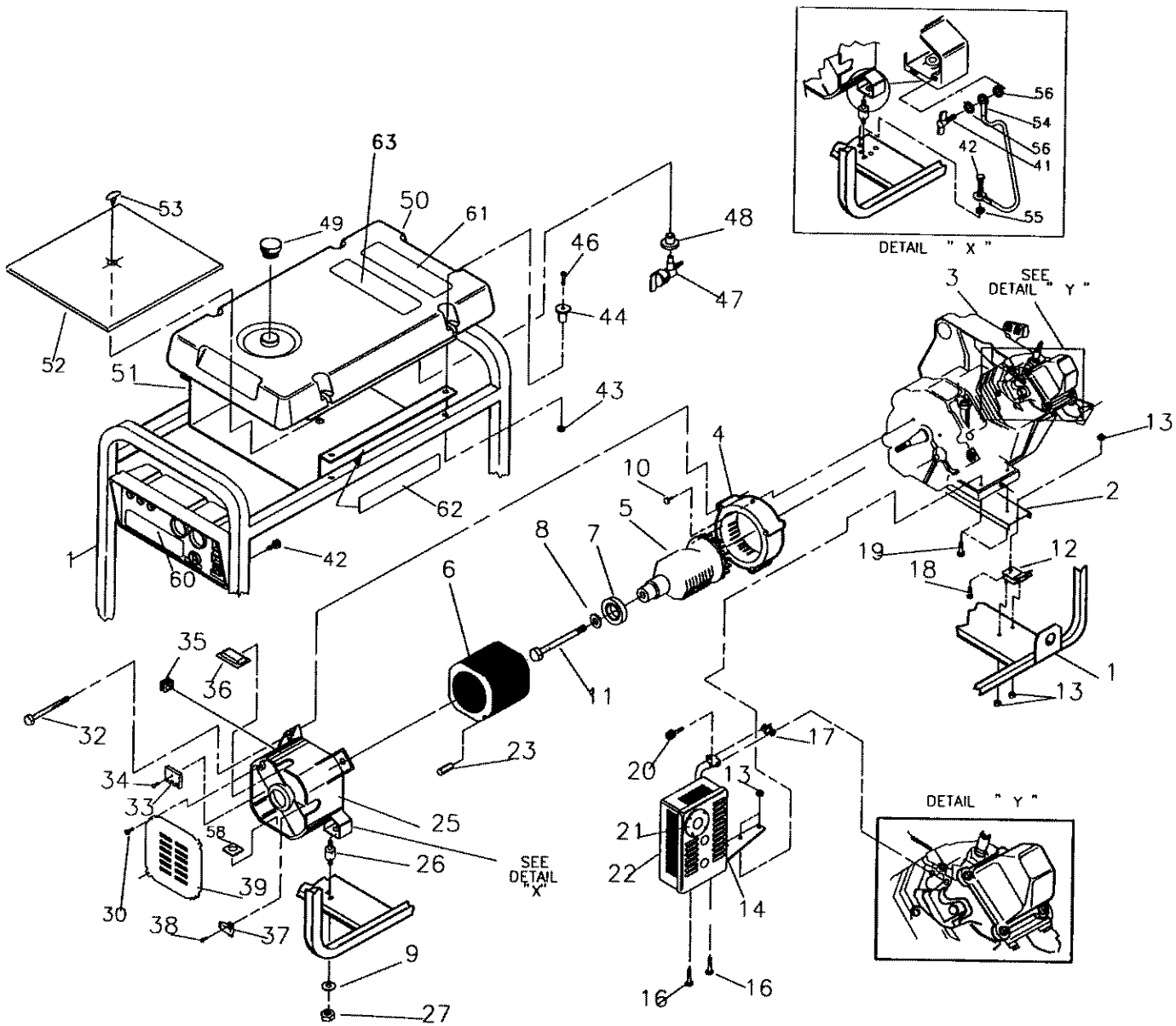

Extended Life Generator

**REPAIR PARTS — GENERATOR**

ITEM	DESCRIPTION	PART NO.	QTY.
1	XL Cradle	93199	1
2	Engine Support	84021	1
3	7.8 HP XL Engine	ENG96456	1
4	Engine Adaptor Housing	66365	1
5	Rotor Assembly	84141	1
6	Stator Assembly	83540	1
7	Bearing	65791	1
8	M8 Flat Washer	67451	1
9	M8 Lock Washer	22129	2
10	6/16-24 x 3/4 Hex Head Machine Screw	86307	4
11	5/16-24 x 7" Cap Screw	47480	1
12	45° Vibration Mount	84508	2
13	M8 Locking Nut	52858	8
14	Muffler Bracket	83208	1
16	M6-1.00 x 12 Machine Screw w/Lock Washer	66476	2
17	Exhaust Gasket	80314	1
18	M8-1.25 x 20 Phillips Pan Head Machine Screw	70644	1
19	M8 x 35 Phillips Pan Head Machine Screw	84346	3
20	M8-1.25 x 20 Socket Head Cap Screw	40976	2
21	Spark Arrestor Screen	83083	1
22	Muffler	83071	1
23	M4 x 10 Roll Pin	81917	1
25	Rear Bearing Carrier	66825B	1
26	Vibration Mount	85652	2
27	M8 Hex Nut	45771	2
30	M5-8.0 x 10 Taptite	74908	4
32	M6-1.0 x 115 Stator Bolt	86308	4
33	Battery Charge Rectifier	65795	1
34	M5-0.7 x 20 Taptite	66849A	1
35	Rubber Grommet	67022	1
36	Drive Module	84132	1
37	Brush Holder Assembly	66386	1
38	M5-0.7 x 16 Taptite	66849	2
39	Bearing Carrier Cover	67025	1
41	M6-1.0 x 16mm Wing Screw	86494	1
42	10-16 Self Drilling Cap Screw	86292	5
43	M6 Flange Lock Nut	77395	4
44	Tank Grommet	83465	4
46	M6-1.0 x 60 (black) Machine Screw	78831B	4
47	Tank Valve	80270	1
48	Plastic Tank Bushing	78299	1
49	Fuel Cap Gauge	90878	1
50	Fuel Tank	83311	1
51	Heat Shield	84042	1
52	#2 1/4" Insulation	84687	1
53	Clip Insulation	85000	1
54	Ground Wire	143-53621	1
55	#10 Shakeproof	23762	1
56	M6 Shakeproof	26850	2
58	Cable Tie Mount	57593	1
60	Control Panel Decal	92810	1
61	Danger Decal	92982	1
62	Heat Shield Decal	92610	2
63	Start Instruction Decal	93826	1



Two-Year Limited Warranty For "GN" Engine Driven Portable Generators

GENERAC warrants to the original purchaser that the alternator and engine for its portable generator will be free from defects in materials or workmanship for the items and period set forth below from the date of original purchase. This warranty is not transferable and applies only to portable generators driven by a GN-Series Generac warranted engine.

	Consumer*	Commercial*
Alternator	2 years (2nd year parts only)	1 year
Engine	2 years (2nd year parts only)	1 year

With the exception of European Community Countries, all units bound for export shall be warranted for One (1) Year in Consumer applications, and 90 days in Commercial applications as defined below.

***NOTE: For the purpose of this warranty "consumer use" means personal residential household use by original purchaser. This does not apply to units used for Prime Power in place of utility. "Commercial Use" means all other uses, including prime power, rental, construction, commercial and income producing purposes. Once a generator has experienced commercial use, it shall thereafter be considered a commercial use generator for the purposes of this warranty.**

During said warranty period, GENERAC will, at its option, repair or replace any part which, upon examination by GENERAC, is found to be defective under normal use and service**. Starting batteries are not warranted by GENERAC. All transportation costs under warranty, including return to the factory if necessary, are to be borne by the purchaser and prepaid by him. This warranty does not cover normal maintenance and service and does not apply to a generator set, alternator or engine, or parts which have been subjected to improper or unauthorized installation or alteration, misuse, negligence, accident, overloading, overspeeding, improper maintenance, repair or storage so as, in GENERAC'S judgement, to adversely affect its performance and reliability.

****NORMAL WEAR: As with all mechanical devices, the GN-Series engines need periodic parts service and replacement to perform well. This warranty will not cover repair when normal use has exhausted the life of a part or an engine.**

THERE IS NO OTHER EXPRESS WARRANTY. GENERAC HEREBY DISCLAIMS ANY AND ALL IMPLIED WARRANTIES, INCLUDING BUT NOT LIMITED TO THOSE OF MERCHANTABILITY AND FITNESS FOR A PARTICULAR PURPOSE TO THE EXTENT PERMITTED BY LAW. THE DURATION OF ANY IMPLIED WARRANTIES WHICH CANNOT BE DISCLAIMED IS LIMITED TO THE TIME PERIOD AS SPECIFIED IN THE EXPRESS WARRANTY. LIABILITY FOR CONSEQUENTIAL, INCIDENTAL OR SPECIAL DAMAGES UNDER ANY AND ALL WARRANTIES IS EXCLUDED. Some states do not allow limitations on how long an implied warranty lasts, or the exclusion or limitation of incidental or consequential damages, so the above limitations or exclusions may not apply to you. This warranty gives you specific legal rights and your may also have other rights, which vary from state to state.

For service, see your nearest GENERAC authorized warranty service facility or call 1-800-333-1322. Warranty service can be performed only by a GENERAC authorized service facility. This warranty will not apply to service at any other facility. At the time of requesting warranty service, evidence of original purchase date must be presented.

Generac Corporation
P.O. Box 8
Waukesha, WI 53187
Telephone: (414) 544-4811
Fax: (414) 544-4851