

**GENERAC<sup>®</sup>**  
Portable Products

# 3100WATT

*Portable Generator Owner's Manual*

**Problems?  
Questions?**  
Before taking your unit  
back to the store,  
call the generator  
helpline at

**1-800-270-1408  
M-F 8-5 CT**

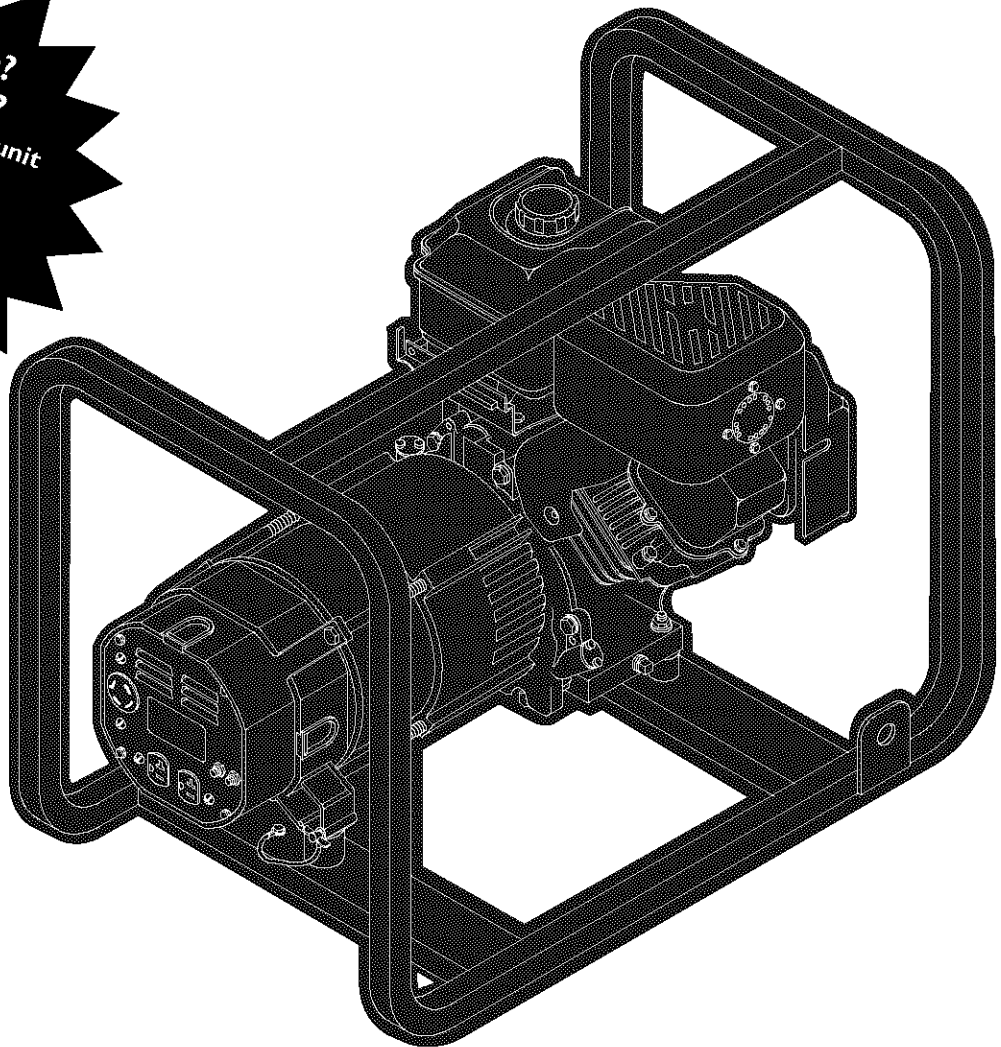

Model No. 1575-0 (3,100 Watt AC Generator) Manual No. 188385 Revision 0 (4/6/2001)

Visit our Generac website: [www.generac-portables.com](http://www.generac-portables.com)



This is the safety alert symbol. It is used to alert you to potential personal injury hazards. Obey all safety messages that follow this symbol to avoid possible injury or death.



## EQUIPMENT DESCRIPTION

The generator is an engine-driven, revolving field, alternating current (AC) generator. It was designed to supply electrical power for operating compatible electrical lighting, appliance, tool and motor loads. This manual contains information for a generator that operates 120 and/or 240 Volt, single phase, 60 Hz devices that require up to 3,100 watts (3.1 kW) of power that pull up to 25.8 Amps at 120 Volts or 12.9 Amps at 240 Volts.

**CAUTION! Do Not** exceed the generator's wattage/ampere capacity. Add up the rated watts of all devices you are connecting to generator receptacles at one time. This total should not be greater than 3,100 watts. See "Don't Overload the Generator" on page 8.

The 3,100 watt portable generator has the following features:

- 120/240 Volt, 20 Amp locking receptacle.
- 120 Volt, 20 Amp duplex receptacle.
- 3 quart overhead fuel tank.
- The generator's revolving field is driven at about 3,600 rpm by a Briggs and Stratton 5.5 h.p. engine.

 **CAUTION! Do Not** tamper with engine governed speed. High operating speeds are dangerous and increase risk of personal injury or damage to equipment. The generator supplies correct rated frequency and voltage only when running at proper governed speed. Incorrect frequency and/or voltage can damage some connected electrical loads. Operating at excessively low speeds imposes a heavy load at such reduced speeds, when adequate engine power is not available, and may shorten engine life.

## SAFETY RULES

This generator set was designed and manufactured for specific applications. **Do Not** attempt to modify the unit or use it for any application it was not designed for. If you have any questions about your generator's application, ask your dealer/distributor or consult the factory.

The manufacturer could not possibly anticipate every circumstance that might involve a hazard. For that reason warnings in the manual and warnings on tags or decals affixed to the unit are not all-inclusive. If you intend to handle, operate or service the unit by a procedure or method not specifically recommended by the manufacturer, first make sure that such a procedure or method will not render this equipment unsafe or pose a threat to you and others.

**Read this manual carefully and become familiar with your generator set. Know its applications, its limitations and any hazards involved.**

 **WARNING:**   
The engine exhaust from this product contains chemicals known to the State of California to cause cancer, birth defects, or other reproductive harm.

 **DANGER!** You must isolate the generator from the electric utility by opening the electrical system's main circuit breaker or main switch if this unit is used for backup power. **Failure to isolate the generator from the power utility may result in injury or death to electric utility workers and damage to the generator** due to a backfeed of electrical energy. Whenever unit is providing backup power, the electric utility must be notified.

 **DANGER!** Generator exhaust gases contain **DEADLY** carbon monoxide gas. Carbon monoxide, if breathed in sufficient concentrations, can cause unconsciousness or death. Operate this equipment outdoors where adequate ventilation is available.

The Emission Control System for this generator is warranted for standards set by the Environmental Protection Agency. For warranty information refer to the engine owner's manual.

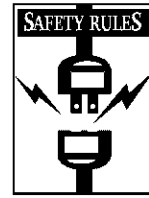

- The generator produces a very powerful voltage that can cause serious injury or death by electrocution. **Never** touch bare wires or receptacles. **Never** permit a child or any unqualified person to operate the generator.
- **Never** handle any kind of electrical cord or device while standing in water, while barefoot or while hands or feet are wet. Death or serious injury from electrocution may result.
- Use a ground fault circuit interrupter (GFCI) in any damp or highly conductive area (such as metal decking or steel work).
- **Never** use worn, bare, frayed or otherwise damaged electrical cords with the generator. Death, serious injury and property damage from electrical shock may result.
- **Gasoline is highly FLAMMABLE and its vapors are EXPLOSIVE. Never allow smoking, open flames, sparks or heat in the vicinity while handling gasoline.** Avoid spilling gasoline on a hot engine. Comply with all laws regulating storage and handling of gasoline.
- **Do Not** overfill the fuel tank. Always allow room for fuel expansion. **If tank is overfilled, fuel can overflow onto a hot engine and cause a FIRE or an EXPLOSION.**
- **Never** store a generator with fuel in the tank where gasoline vapors might reach an open flame, spark or pilot light (as on a furnace, water heater, clothes dryer). **FIRE** or an **EXPLOSION** may result.
- The unit requires an adequate flow of cooling air for its continued proper operation. **Never** operate the unit inside any room or enclosure where the free flow of cooling air into and out of the unit might be obstructed. Allow at least 2 feet of clearance on all sides of generator, even while operating unit outdoors, or you could damage the unit.
- **Never** start, or stop the unit with electrical loads connected to receptacles with the connected devices turned ON. Start the engine and let it stabilize before connecting any electrical loads. Disconnect all electrical loads before shutting down the generator.
- **Do Not** insert any object through cooling slots of the engine. You could damage the unit or injure yourself.

- **Never operate the generator:**

- in rain; in any enclosed compartment; when connected electrical devices overheat; if electrical output is lost; if engine or generator sparks; if flame or smoke is observed while unit is running; if unit vibrates excessively.

## GROUNDING THE GENERATOR

The National Electric Code requires the frame and external electrically conductive parts of the generator be properly connected to approved earth ground. Local electrical codes may also require proper grounding of the unit. For this purpose, a grounding wing nut (Figure 1) is provided on the cradle.

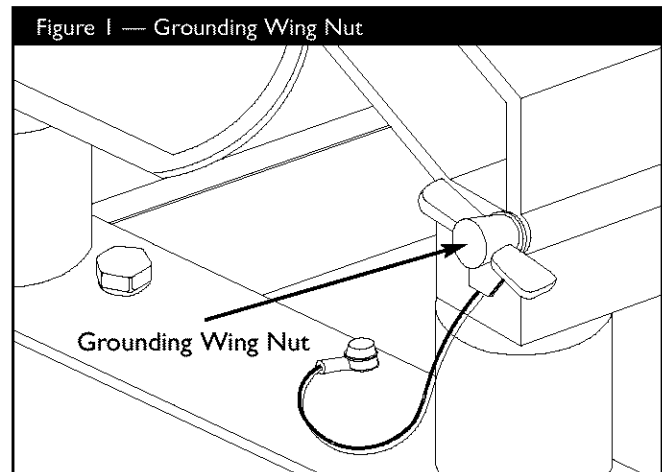

Generally, connecting a No. 12 AWG (American Wire Gauge) stranded copper wire to the grounding wing nut and to an earth-driven copper or brass grounding rod (electrode) provides adequate protection against electrical shock. However, local codes may vary widely. Consult with a local electrician for grounding requirements in your area. Be sure to keep the ground wire attached while you connect the electrode.

Properly grounding the generator helps prevent electrical shock if ground fault conditions exist in the generator or in connected electrical devices. Proper grounding also helps dissipate static electricity, which often builds up in ungrounded devices.



## KNOW YOUR GENERATOR

**Read this owner's manual and safety rules before operating your generator.**

Compare the illustrations with your generator, to familiarize yourself with the locations of various controls and adjustments. Save this manual for future reference.

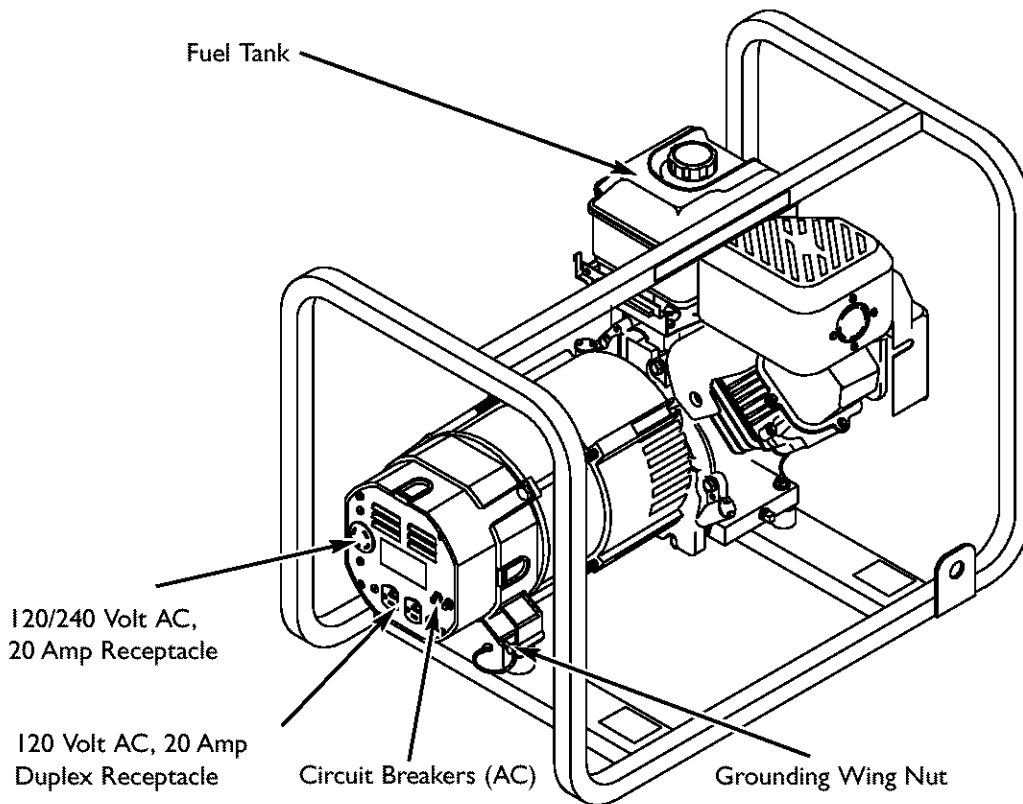

**120 Volt AC, 20 Amp Duplex Receptacle** — May be used to supply electrical power for the operation of 120 Volt AC, 20 Amp, single phase, 60 Hz electrical lighting, appliance, tool and motor loads.

**120/240 Volt AC, 20 Amp Receptacle** — May be used to supply electrical power for the operation of 120 and/or 240 Volt AC, 20 Amp, single phase, 60 Hz electrical lighting, appliance, tool and motor loads.

**Circuit Breakers (AC)** — Each receptacle is provided with a push-to-reset circuit breaker to protect the generator against electrical overload.

**Fuel Tank** — Capacity of 3 U.S. quarts.

**Grounding Wing Nut** — Provides a tie-point for connecting the generator frame to earth ground.

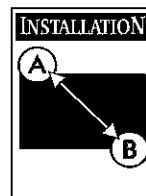

## CARTON CONTENTS

Check all contents. If any parts are missing or damaged, call the generator helpline at **1-800-270-1408**. Review “Cold Weather Operation” on page 6. Shipped with your generator are:

- Main unit
- Engine and generator owner’s manuals

## BEFORE STARTING THE ENGINE

### Add Engine Oil

- Make sure unit is on a level surface.
- Follow the oil recommendations and oil fill instructions given in the engine owner’s manual.

**CAUTION!** Any attempt to crank or start the engine before it has been properly serviced with the recommended oil results in an engine failure.

**NOTE:** The generator’s revolving field rides on a pre-lubricated and sealed ball bearing that requires no additional lubrication for the life of the bearing.

### Add Gasoline

**WARNING!** Never fill fuel tank indoors. Never fill fuel tank when engine is running or hot. Do Not light a cigarette or smoke when filling the fuel tank.

**WARNING!** Do Not overfill the fuel tank. Always leave room for expansion.

- Use **regular UNLEADED gasoline** in the generator. **Do Not** use premium gasoline. **Do Not** mix oil with gasoline. **Do Not** overfill the gas tank.
- Clean area around fuel fill cap; remove cap.
- Fill fuel tank with clean, fresh, unleaded gasoline. Be careful not to overfill. Allow 1.5" of tank space for fuel expansion, as shown in Figure 2.

Figure 2 — Typical Tank Expansion Space

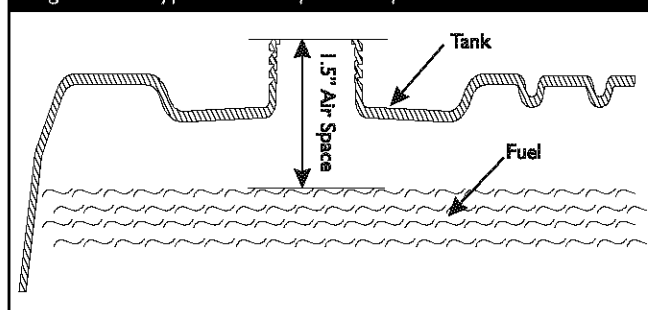

- Install fuel cap and wipe up any spilled gasoline.

**IMPORTANT:** It is important to prevent gum deposits from forming in essential fuel system parts such as the carburetor, fuel filter, fuel hose or tank during storage. Also, experience indicates that alcohol-blended fuels (called gasohol, ethanol or methanol) can attract moisture, which leads to separation and formation of acids during storage. Acidic gas can damage the fuel system of an engine while in storage. To avoid engine problems, the fuel system should be emptied before storage of 30 days or longer. See “Storage” on page 9. **Never** use engine or carburetor cleaner products in the fuel tank or permanent damage may occur.

**IMPORTANT:** When running your unit in cold weather be sure to shelter the unit from the wind.



## OPERATING THE GENERATOR

**CAUTION!** Never start or stop unit with electrical loads connected AND with the connected devices turned ON.

### Starting the Engine

Disconnect all electrical loads from the generator. Use the following start instruction steps by numerical order:

1. Turn the fuel valve to the “On” position (Figure 3).

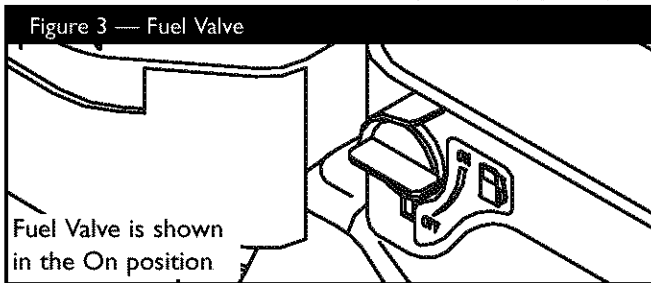

2. Place the choke lever in the “Choke” position (Figure 4).

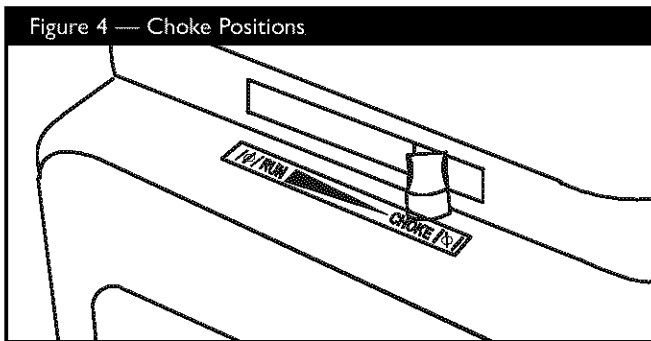

3. Set the rocker switch to “On” position (Figure 5).

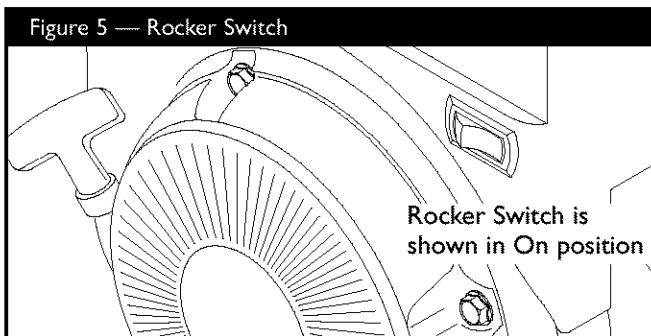

4. Grasp the recoil handle and pull slowly until slight resistance is felt. Then pull rapidly to start engine.
5. Move choke lever to “Run” position a short distance at a time over several seconds in warm weather or minutes in cold weather. Let engine run smoothly before each change. Operate with choke in “Run” position.

Refer to the engine owner’s manual for complete starting instructions.

### Connecting Electrical Loads

- Let engine stabilize and warm up for a few minutes after starting.
- Plug in and turn on the desired 120 and/or 240 Volt AC, single phase, 60 Hz electrical loads.
- **Do Not** connect 240 Volt loads to the 120 Volt duplex receptacles.
- **Do Not** connect 3–phase loads to the generator.
- **Do Not** connect 50 Hz loads to the generator.
- **DO NOT OVERLOAD THE GENERATOR.** See “Don’t Overload the Generator” on page 8.

### Stopping the Engine

- Unplug **all** electrical loads from generator panel receptacles. **Never** start or stop engine with electrical devices plugged in and turned **ON**.
- Let engine run at no-load for several minutes to stabilize the internal temperatures of engine and generator.
- Move rocker switch to “Off” position.
- Move the fuel valve to the “Off” position.

### Cold Weather Operation

Under certain weather conditions (temperatures below 40°F [4°C] and a high dew point), your Generac generator may experience problems.

In an emergency, use the original shipping box as a temporary shelter:

- Cut off all flaps.
- Cut out one of the long sides of the box to expose exhaust side of unit. Ensure a minimum of two feet clearance between open side of box and nearest object.
- Cut appropriate slots to access receptacles of unit.



- Start unit, then place box over it.

**CAUTION!** Remove shelter when temperature is above 40°F [4°C].

For a more permanent shelter, build a structure that will enclose three sides and the top of the generator.

- Make sure entire muffler-side of generator is exposed, as shown in Figure 6.

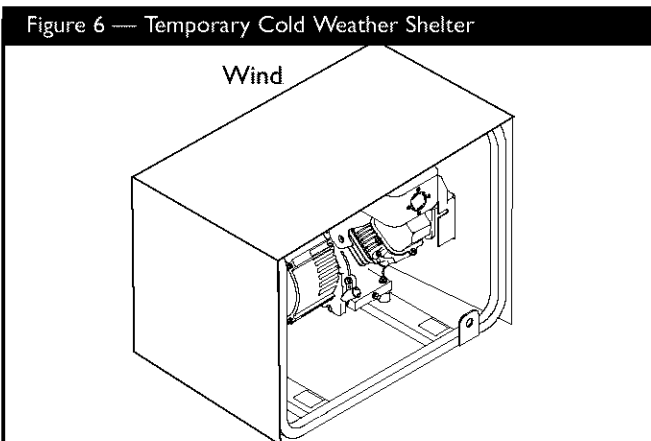

**NOTE:** A typical unit is shown here, your unit may differ in appearance.

- Ensure a minimum of two feet clearance between open side of box and nearest object.
- Face exposed end away from wind and elements.
- Enclosure should hold enough heat created by the generator to prevent problems.

## RECEPTACLES

This generator is equipped with the following receptacles:

### 120 Volt AC, 20 Amp Duplex Receptacle

This receptacle (Figure 7) is protected against overload by a push-to-reset circuit breaker.

Use each receptacle to operate 120 Volt AC, single-phase, 60 Hz electrical loads requiring up to 2,400 watts (2.4 kW) at 20 Amps of current. Use cord sets that are rated for 125 Volts at 20 Amps (or greater).

Figure 7 — 120 Volt, 20 Amp Duplex Receptacle

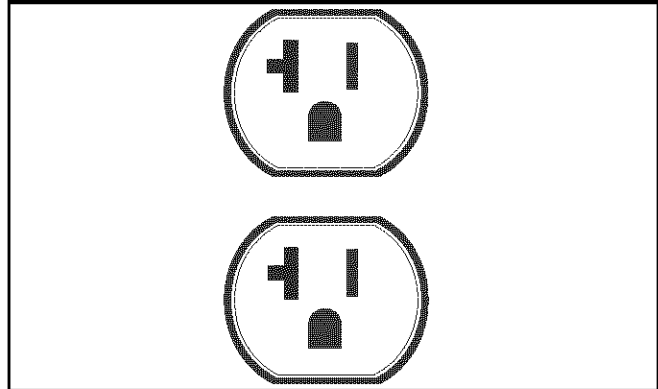

### 120/240 Volt AC, 20 Amp Locking Receptacle

Use a NEMA L14-20 plug with this receptacle. Connect a 4-wire cord set rated for 250 Volts AC at 20 Amps (or greater) (Figure 8). You can use the same 4-wire cord if you plan to run a 120 Volt load.

Figure 8 — 120/240 Volt, 20 Amp Locking Receptacle

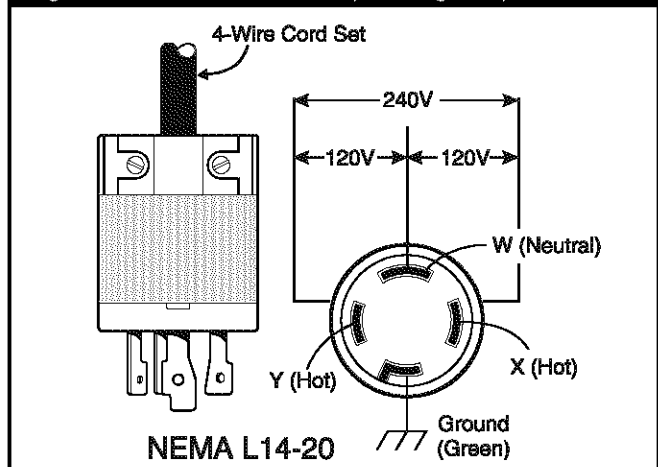

This receptacle powers 120/240 Volt AC, 60 Hz, single phase loads requiring up to 3,100 watts of power at 20 Amps for 120 Volts or 3,100 watts of power (3.1 kW) at 12.9 Amps for 240 Volts. The outlet is protected by a push-to-reset circuit breaker.

**CAUTION!** Although this outlet states it has a 120/240 Volt 20 Amp rating (up to 4,800 watts), the generator is only rated for 3,100 watts. Powering loads that exceed the wattage/ampere capacity of the generator can damage it or cause serious injuries.



# DON'T OVERLOAD THE GENERATOR

Overloading a generator in excess of its rated wattage capacity can result in damage to generator and to connected electrical devices. Observe the following, to prevent overloading the unit:

- Add up the total wattage of all electrical devices to be connected at one time. This total should NOT be greater than the generator's wattage capacity.
- The rated wattage of lights can be taken from light bulbs. The rated wattage of tools, appliances and motors can usually be found on a data plate or decal affixed to the device.

- If the appliance, tool or motor does not give wattage, multiply 120 Volts times ampere rating to determine watts (volts x amps = watts).
- Some electric motors, such as induction types, require about three times more watts of power for starting than for running. This surge of power lasts for only a few seconds when starting such motors. Be sure you allow for this high starting wattage when selecting electrical devices to connect to your generator. First figure the watts needed to start the largest motor. Add to that figure the running watts of all other connected loads.
- A Wattage Reference Guide (Figure 10) is provided to help you determine how many items the generator can operate at one time.

Figure 10 — Wattage Reference Guide

Recreational/Home Uses		Professional/Contractor Uses	
Tool/Appliance.....	Watts	Tool/Appliance.....	Watts
AM/FM clock radio.....	50	*1/3 hp airless sprayer.....	600
Light bulb.....	100	3/8" hammer drill.....	600
Fan.....	200	Variable speed Sawzall®.....	960
20" color TV.....	400	½" power drill.....	1000
*Deep freezer.....	500	Quartz-halogen work light.....	1000
Personal computer and 15" monitor.....	800	Belt sander.....	1200
*1/3 hp furnace fan blower.....	800	7 ¼" circular saw.....	1500
Microwave oven.....	800	7 ¼" worm drive saw.....	1600
*18 cu ft refrigerator.....	800	*1½ hp air compressor.....	1800
Sump pump.....	1000	*10" power miter saw.....	1800
Electric skillet.....	1250	6" bench grinder.....	1800
*½ hp water well pump.....	1400	*6" table planer.....	1800
*12,000 Btu window air conditioner.....	1400	*10" table/radial arm saw.....	2000
Space heater.....	1800	Wire feed welder.....	2400
Electric water heater.....	4000	* allow 3 times listed watts for starting this device	



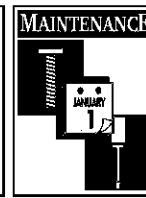

## SPECIFICATIONS

Maximum Surge Watts	3,875 Watts
Continuous Wattage Capacity	3,100 Watts
Power Factor	1.0
Rated Maximum Continuous Load Current	
At 120 Volts	25.8 Amps
At 240 Volts	12.9 Amps
Phase	1-phase
Rated Frequency	60 Hertz

## MAINTENANCE RECOMMENDATIONS

The Owner/Operator is responsible for making sure that all periodic maintenance tasks are completed on a timely basis; that all discrepancies are corrected; and that the unit is kept clean and properly stored. **Never operate a damaged or defective generator.**

### Engine Maintenance

See engine owner's manual for instructions.

**CAUTION!** Avoid prolonged or repeated skin contact with used motor oil. Used motor oil has been shown to cause skin cancer in certain laboratory animals. Thoroughly wash exposed areas with soap and water.  
**KEEP OUT OF REACH OF CHILDREN. DON'T POLLUTE. CONSERVE RESOURCES. RETURN USED OIL TO COLLECTION CENTERS.**

### Generator Maintenance

Generator maintenance consists of keeping the unit clean and dry. Operate and store the unit in a clean dry environment where it will not be exposed to excessive dust, dirt, moisture or any corrosive vapors. Cooling air slots in the generator must not become clogged with snow, leaves or any other foreign material.

**NOTE: Do Not** use a garden hose to clean the generator. Water can enter engine fuel system and cause problems. In addition, if water enters generator through cooling air slots, some of the water will be retained in voids and cracks of the rotor and stator winding insulation. Water and dirt buildup on the generator internal windings will

eventually decrease the insulation resistance of these windings.

### To Clean the Generator

- Use a damp cloth to wipe exterior surfaces clean.
- Soft, bristle brush may be used to loosen caked on dirt or oil.
- A vacuum cleaner may be used to pick up loose dirt and debris.
- Low pressure air (not to exceed 25 psi) may be used to blow away dirt. Inspect cooling air slots and opening on generator. These openings must be kept clean and unobstructed.

## STORAGE

The unit should be started at least once every seven days and allowed to run at least 30 minutes. If this cannot be done and you must store the unit for more than 30 days, use the following guidelines to prepare it for storage.

### Generator Storage

- Clean the generator as outlined in "To Clean the Generator" on this page.
- Check that cooling air slots and openings on generator are open and unobstructed.

**CAUTION!** Storage covers can be flammable. **Do Not** place a storage cover over a hot generator. Let the unit cool for a sufficient time before placing the cover on the unit.

### Engine Storage

See engine owner's manual for instructions.

### Other Storage Tips

- **Do Not** store gasoline from one season to another.
- Replace your gasoline can if it starts to rust. Rust and/or dirt in a gasoline can cause problems when you use that fuel with this unit.
- Store in clean and dry area.



NOTES

## NOTES

---

---

---

---

---

---

---

---

---

---

---

---

---

---

---

---

---

---

---

---

---

---

---

---

---

---

---

---



## TROUBLESHOOTING

<b>Problem</b>	<b>Cause</b>	<b>Solution</b>
<b>Engine is running, but no AC output is available.</b>	<ol style="list-style-type: none"> <li>1. Circuit breaker is open.</li> <li>2. Poor connection or defective cord set.</li> <li>3. Connected device is bad.</li> <li>4. Fault in generator.</li> </ol>	<ol style="list-style-type: none"> <li>1. Reset circuit breaker.</li> <li>2. Check and repair.</li> <li>3. Connect another device that is in good condition.</li> <li>4. Contact Generac service facility.</li> </ol>
<b>Engine runs good but bogs down when loads are connected.</b>	<ol style="list-style-type: none"> <li>1. Short circuit in a connected load.</li> <li>2. Generator is overloaded.</li> <li>3. Engine speed is too slow.</li> <li>4. Shorted generator circuit.</li> </ol>	<ol style="list-style-type: none"> <li>1. Disconnect shorted electrical load.</li> <li>2. See "Don't Overload the Generator" on page 8.</li> <li>3. Contact Briggs and Stratton service facility.</li> <li>4. Contact Generac service facility.</li> </ol>
<b>Engine will not start; or starts and runs rough.</b>	<ol style="list-style-type: none"> <li>1. Rocker switch set to "Off".</li> <li>2. Dirty air cleaner.</li> <li>3. Out of gasoline.</li> <li>4. Stale gasoline.</li> <li>5. Spark plug wire not connected to spark plug.</li> <li>6. Bad spark plug.</li> <li>7. Water in gasoline.</li> <li>8. Overchoking.</li> <li>9. Low oil level.</li> <li>10. Excessively rich fuel mixture.</li> <li>11. Intake valve stuck open or closed.</li> <li>12. Engine has lost compression.</li> </ol>	<ol style="list-style-type: none"> <li>1. Set switch to "On".</li> <li>2. Clean or replace air cleaner.</li> <li>3. Fill fuel tank.</li> <li>4. Drain gas tank and fill with fresh fuel.</li> <li>5. Connect wire to spark plug.</li> <li>6. Replace spark plug.</li> <li>7. Drain gas tank; fill with fresh fuel.</li> <li>8. Set choke to "Run" position.</li> <li>9. Fill crankcase to proper level.</li> <li>10. Contact Briggs and Stratton service facility.</li> <li>11. Contact Briggs and Stratton service facility.</li> <li>12. Contact Briggs and Stratton service facility.</li> </ol>
<b>Engine shuts down during operation.</b>	<ol style="list-style-type: none"> <li>1. Out of gasoline.</li> <li>2. Low oil level.</li> <li>3. Fault in engine.</li> </ol>	<ol style="list-style-type: none"> <li>1. Fill fuel tank.</li> <li>2. Fill crankcase to proper level.</li> <li>3. Contact Briggs and Stratton service facility.</li> </ol>
<b>Engine lacks power.</b>	<ol style="list-style-type: none"> <li>1. Load is too high.</li> <li>2. Dirty air filter.</li> <li>3. Engine needs to be serviced.</li> </ol>	<ol style="list-style-type: none"> <li>1. See "Don't Overload the Generator" on page 8.</li> <li>2. Replace air filter.</li> <li>3. Contact Briggs and Stratton service facility.</li> </ol>
<b>Engine "hunts" or falters.</b>	<ol style="list-style-type: none"> <li>1. Choke is opened too soon.</li> <li>2. Carburetor is running too rich or too lean.</li> </ol>	<ol style="list-style-type: none"> <li>1. Move choke to halfway position till engine runs smoothly.</li> <li>2. Contact Briggs and Stratton service facility.</li> </ol>

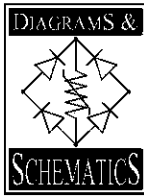

# SCHEMATIC AND WIRING DIAGRAM

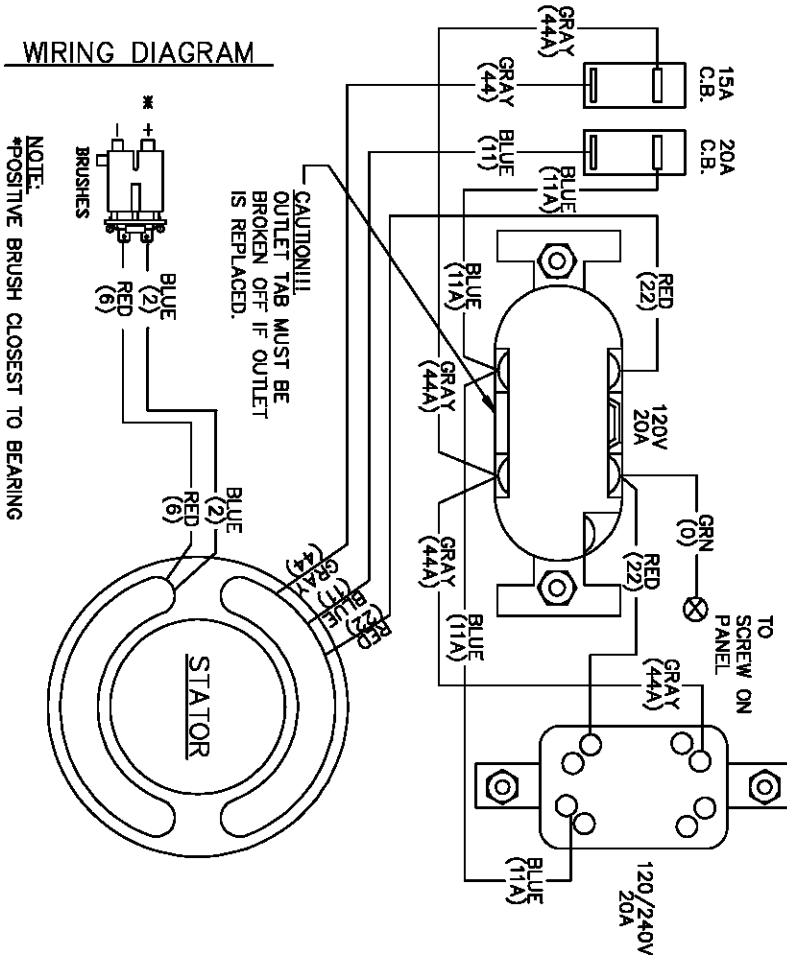
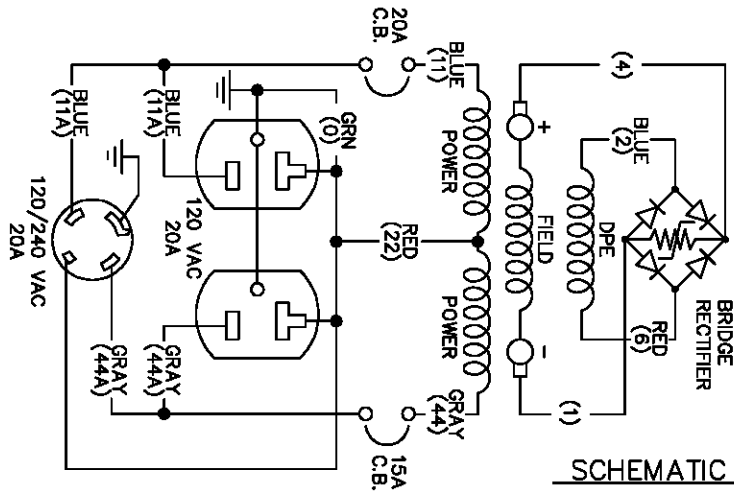

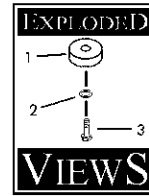

## EXPLODED VIEW AND PARTS LIST- CONTROL PANEL

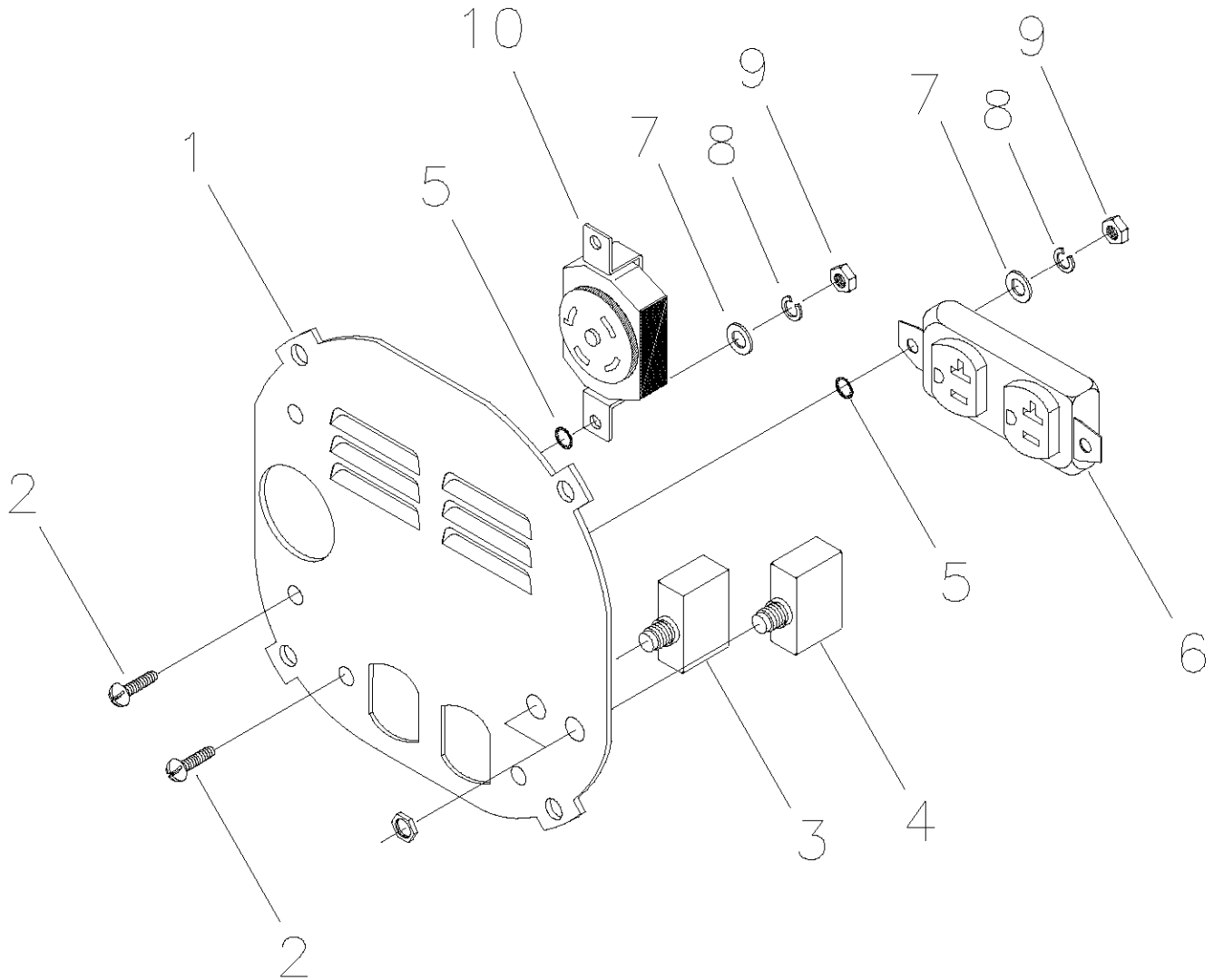

Item	Part #	Qty	Description	Item	Part #	Qty	Description
1	B95600	1	COVER, Control Panel	6	68759	1	OUTLET, 120V, 20A Duplex
2	75475	4	PPHMS, M4 0.7 x 10	7	38150	4	WASHER, Flat, #8
3	94396B	1	CIRCUIT BREAKER	8	22264	4	WASHER, Lock #8
4	94396A	1	CIRCUIT BREAKER	9	51715	4	NUT, M4 - 0.7 Hex
5	23365	4	WASHER, #8 Shakeproof	10	68867	1	TWISTLOCK, 120/240V, 20 Amp

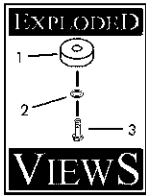

# EXPLODED VIEW AND PARTS LIST- MAIN UNIT

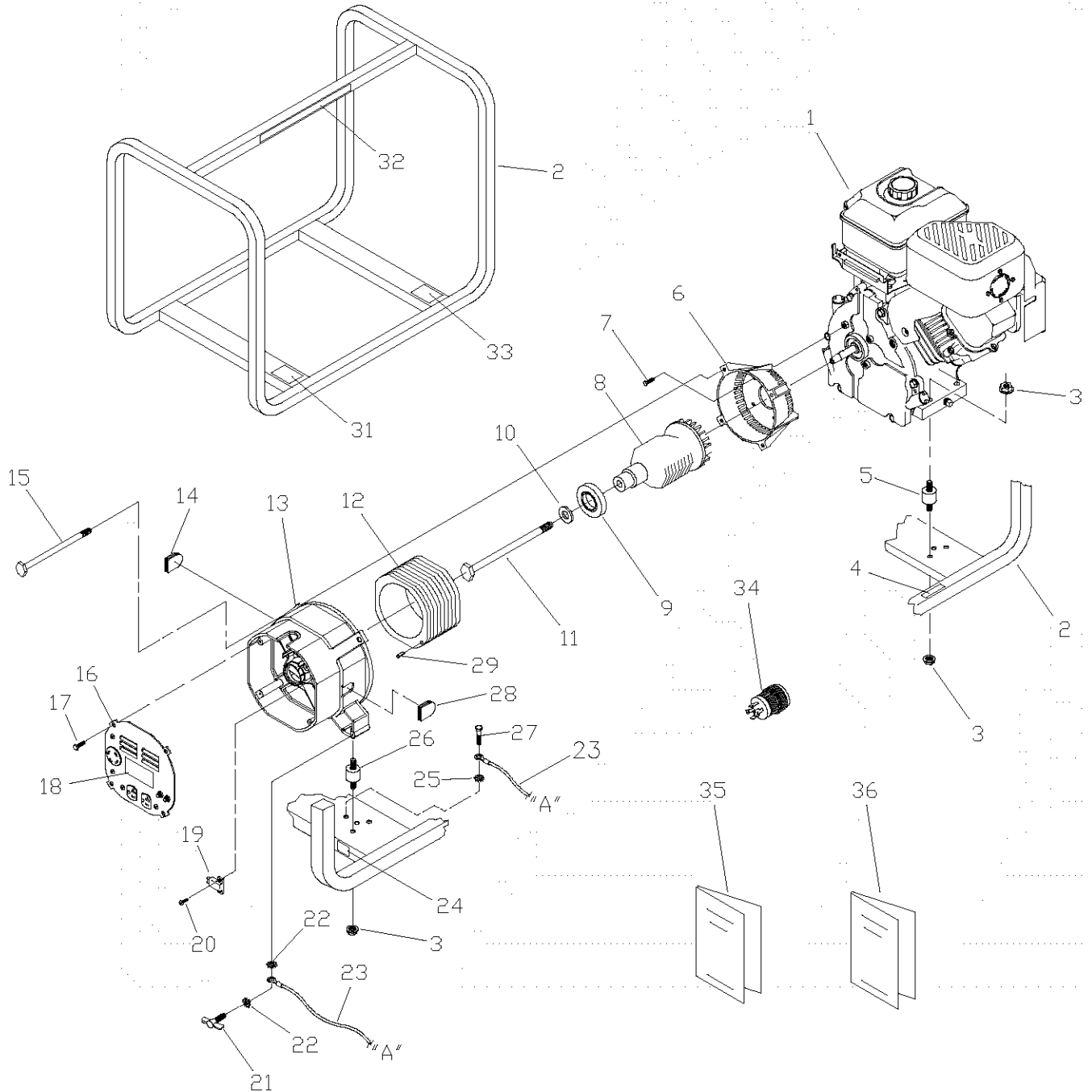

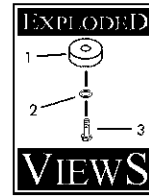

Item	Part #	Qty	Description
1	NSP	1	ENGINE
2	A188299	1	ASSEMBLY, Cradle
3	67989	6	NUT, M8 Flanged Serrated
4	77816	1	DECAL, Caution Hot Muffler
5	85651	2	MOUNT, Vibration Engine
6	66365	1	HOUSING, Engine Adapter
7	86307	4	CAPSCREW, Hx Hd 5/16"-24 x 3/4"
8	188075	1	ASSEMBLY, Rotor
9	65791	1	BEARING, Ball
10	96796	1	WASHER, Flat (special)
11	24823	1	BOLT, Rotor 5/16" - 24 x 7.00"
12	91838J	1	ASSEMBLY, Stator
13	66825B	1	CARRIER, Rear Bearing
14	67022	1	GROMMET, Rubber
15	86308	4	BOLT, Stator M6-1.0 x 115mm
16	95003A	1	ASSY., Control Panel
17	74908	4	SCREW, M5 0.80 x 10mm Taptite
18	188554	1	DECAL, Control Panel
19	91825	1	RECTIFIER, Brush & Bridge
20	66849	2	SCREW, M5 - .80 x 16mm Taptite
21	86494	1	SCREW, M6 - 1.0 x 16 Wing
22	26850	2	WASHER, M6 1/4 Shakeproof
23	1435362I	1	WIRE, Ground
24	B4986	1	DECAL, Ground
25	23762	1	WASHER, #10 Shakeproof
26	85652	2	MOUNT, Vibration Alt.
27	B2153	1	CAPSCREW, Self Driller #10
28	84242	2	GROMMET, Plastic RBC
29	81917	1	PIN, Roll, M4 x 10
31	93639	1	DECAL, Danger (English)
32	188555	2	DECAL, Unit
33	99541	1	DECAL, Start Instructions
34	43483	1	PLUG, 250V, 20Amp
35	188385	1	MANUAL, Owners
36	188637	1	MANUAL, Engine

# **LIMITED WARRANTY FOR PORTABLE GENERATORS**

**(EXCEPT GN ENGINE SERIES)**

Generac Portable Products (hereafter referred to as the COMPANY) warrants to the original purchaser that its generator will be free from defects in materials or workmanship for a period of one year\* from the date of original purchase. This warranty does not apply to units used for prime power in place of utility. This warranty does not include the gasoline engine when furnished or attached because such engine is covered solely by the warranty of the manufacturer of the engine. Starting batteries are not warranted by the COMPANY.

**\*NOTE:** Rental units, demonstrators, commercial applications, such as construction or income producing, are warranted for 90 days. Rental units, demonstrators, or commercial applications such as construction or utility which are resold are not covered under warranty by the COMPANY. Any warranty, whether expressed or implied, rests solely with the seller.

During said warranty period, the COMPANY will, at its option, repair or replace any part which, upon examination by the COMPANY is found to be defective under normal use and service. All transportation costs under warranty, including return to the factory if necessary, are to be borne by the purchaser and prepaid by the purchaser. This warranty does not include nominal maintenance and service and does not apply to a generator set, or parts, which have been subjected to improper or unauthorized installation, misuse, negligence, accident, overloading, overspeeding, improper maintenance, repair or storage so as, in the COMPANY's judgment, to adversely affect its performance and reliability.

THERE IS NO OTHER EXPRESS WARRANTY. THE COMPANY HEREBY DISCLAIMS ANY AND ALL IMPLIED WARRANTIES, INCLUDING BUT NOT LIMITED TO THOSE OF MERCHANTABILITY AND FITNESS FOR A PARTICULAR PURPOSE TO THE EXTENT PERMITTED BY LAW. THE DURATION OF ANY IMPLIED WARRANTIES WHICH CANNOT BE DISCLAIMED IS LIMITED TO THE TIME PERIOD AS SPECIFIED IN THE EXPRESS WARRANTY. LIABILITY FOR INCIDENTAL, CONSEQUENTIAL, OR SPECIAL DAMAGES UNDER ANY AND ALL WARRANTIES IS EXCLUDED TO THE EXTENT PERMITTED BY LAW. THE COMPANY ALSO DISCLAIMS ANY RESPONSIBILITY FOR INCIDENTAL OR CONSEQUENTIAL DAMAGES SUCH AS THE LOSS OF TIME OR THE USE OF THE POWER EQUIPMENT, OR ANY COMMERCIAL LOSS DUE TO THE FAILURE OF THE EQUIPMENT; AND ANY IMPLIED WARRANTIES ARE LIMITED TO THE DURATION OF THIS WRITTEN WARRANTY.

Some states do not allow limitations on how long an implied warranty lasts, or the exclusions or limitations of incidental or consequential damages, so the above limitations or exclusions may not apply to you. This warranty gives you specific legal rights and you may also have other rights, which vary from state to state.

This warranty is effective for all products manufactured after June, 1998, and supersedes all prior warranties of the COMPANY.

For service, contact your nearest COMPANY authorized warranty service facility or call 1-877-544-0982. Warranty service can only be performed by a COMPANY authorized service facility. At the time of requesting warranty service, evidence of original purchase date must be presented.

**GENERAC PORTABLE PRODUCTS**  
Jefferson, Wisconsin U.S.A.