



# GENERAC

*The Reliable Ones*

# SE10000

## *Portable Generator Owner's Manual*

 **DANGER!** This generator is designed for outdoor use only. **Never** use this generator inside any building or enclosure including the generator compartment of a recreational vehicle (RV). **Carbon monoxide poisoning, fire and/or an explosion may result.** No user performed modifications, including venting of exhaust and/or cooling ventilation, will eliminate the danger. Always have at least two feet of clearance on all sides of the generator even while operating the unit outdoors.

 **DANGER!** You must isolate the generator from the electric utility by opening the electrical system's main circuit breaker or main switch if this unit is used for backup power. **Failure to isolate the generator from the power utility may result in injury or death to electric utility workers and damage to the generator** due to a backfeed of electrical energy.

The Emission Control System for this generator is warranted for standards set by the Environmental Protection Agency. For warranty information refer to the engine Owner's manual.

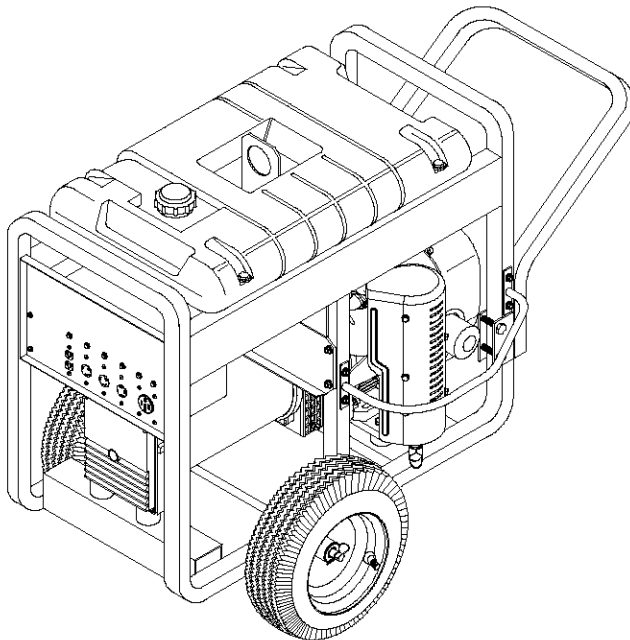

Model No. 1339-0 (10000 Watt AC Generator) Manual No. B4472 Revision 2 (8/17/1999)

Visit our Generac website: [www.generac-portables.com](http://www.generac-portables.com)



This is the safety alert symbol. It is used to alert you to potential personal injury hazards. Obey all safety messages that follow this symbol to avoid possible injury or death.

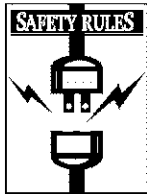

## EQUIPMENT DESCRIPTION

This generator is an engine-driven, revolving field, alternating current (AC) generator. It was designed to supply electrical power for operating compatible electrical lighting, appliance, tool and motor loads. This manual contains information for a generator that operates 120 and/or 240 Volt, single phase, 60Hz devices that require up to 10,000 watts (10.0 kW) of power that pull up to 83.3 Amps at 120 Volts or 41.6 Amps at 240 Volts.

 **CAUTION!** Do not exceed the generator's wattage/ampere capacity. Add up the rated watts of all devices you are connecting to generator receptacles at one time. This total should not be greater than 10,000 watts for this generator. See "Don't Overload the Generator" on page 11.

Every effort has been expended to make sure that the information in this manual is both accurate and current. However, Generac reserves the right to change, alter or otherwise improve the product at any time without prior notice.

 **DANGER!** Do not tamper with engine governed speed. High operating speeds are dangerous and increase the risk of personal injury or damage to equipment. The generator supplies correctly rated frequency and voltage only when running at proper governed speed. Incorrect frequency and/or voltage can damage some connected electrical loads. Operating at excessively low speeds imposes a heavy load and, when adequate engine power is not available, may shorten engine life.

## SAFETY RULES

This generator set was designed and manufactured for specific applications. Do not attempt to modify the unit or use it for any application it was not designed for. If you have any questions about your generator's application, ask your dealer or consult the factory.

The manufacturer could not possibly anticipate every circumstance that might involve a hazard. For that reason, warnings in the manual and warnings on tags or decals affixed to the unit are not all-inclusive. If you intend to handle, operate or service the unit by a procedure or method not specifically recommended by the manufacturer, first make sure that such a procedure or method will not render this equipment unsafe or pose a threat to you and others.

**Read this manual carefully and become familiar with your generator set. Know its applications, its limitations, and any hazards involved.**

 **WARNING:**   
**The engine exhaust from this product contains chemicals known to the State of California to cause cancer, birth defects, or other reproductive harm.**

 **DANGER!** You must isolate the generator from the electric utility by opening the electrical system's main circuit breaker or main switch if this unit is used for backup power. **Failure to isolate the generator from the power utility may result in injury or death to electric utility workers and damage to the generator.**

 **DANGER!** Generator exhaust gases contain **DEADLY carbon monoxide gas**. Carbon monoxide, if breathed in sufficient concentrations can cause unconsciousness or death. Operate this equipment outdoors where adequate ventilation is available.

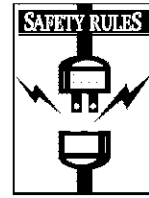

- The generator produces a very powerful voltage that can cause serious injury or death by electrocution. Never touch bare wires or receptacles. Never permit a child or any unqualified person to operate the generator.
- Never handle any kind of electrical cord or device while standing in water, while barefoot or while hands or feet are wet.
- Use a ground fault circuit interrupter (GFCI) in any damp or highly conductive area (such as metal decking or steel work).
- Never use worn, bare, frayed or otherwise damaged electrical cords with the generator.
- **Gasoline is highly FLAMMABLE and its vapors are EXPLOSIVE. Never allow smoking, open flames, sparks or heat in the vicinity while handling gasoline.** Avoid spilling gasoline on a hot engine. Comply with all laws regulating storage and handling of gasoline.
- Do not overfill the fuel tank. Allow room for fuel expansion. **If tank is overfilled, fuel can overflow onto a hot engine and cause a FIRE or an EXPLOSION.**
- Never store a generator with fuel in the tank where gasoline vapors might reach an open flame, spark or pilot light (as on a furnace, water heater, clothes dryer). FIRE or an EXPLOSION may result.
- Do not insert any object through cooling slots of the engine. You could damage the unit or injure yourself.
- The unit requires an adequate flow of cooling air for its continued proper operation. Never operate the unit inside any room or enclosure where the free flow of cooling air into and out of the unit might be obstructed. **Allow at least 3 feet of clearance** on all sides of generator or you could damage the unit.
- **Never operate the generator:** in rain; in any enclosed compartment; if connected electrical devices overheat; if electrical output is lost; if engine or generator sparks; if flame or smoke is observed while unit is running; if unit vibrates excessively.

## GROUNDING THE GENERATOR

The National Electric Code requires the frame and external electrically conductive parts of the generator be properly connected to approved earth ground. Local electrical codes may also require proper grounding of the unit. For this purpose, a grounding wing nut (Figure 1) is provided on the cradle.

Figure 1 — Location of Grounding Wing Nut

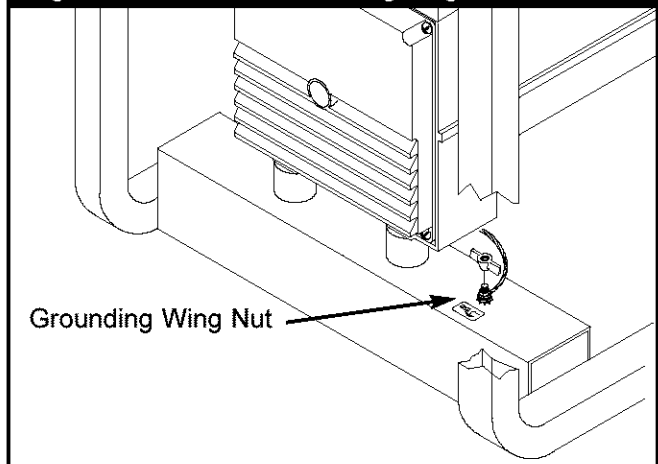

Generally, connecting a No. 12 AWG (American Wire Gauge) stranded copper wire to the grounding wing nut and to an earth-driven copper or brass grounding rod (electrode) provides adequate protection against electrical shock. However, local codes may vary widely. Consult with a local electrician for grounding requirements in your area. Be sure to keep the ground wire attached while you connect the electrode.

Properly grounding the generator helps prevent electrical shock if ground fault conditions exist in the generator or in connected electrical devices. Proper grounding also helps dissipate static electricity, which often builds up in ungrounded devices.

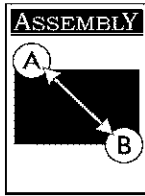

Your generator requires some assembly and is ready for use after it has been properly serviced with the recommended oil and fuel.

**If you have any problems with the assembly of your generator, please call the generator helpline at 1-800-270-1408.**

**IMPORTANT:** Any attempt to run the engine before it has been serviced with the recommended oil will result in an engine failure.

## REMOVE GENERATOR FROM CARTON

- Set the palletted carton on a rigid flat surface.
- Carefully cut bands around the shipping carton.
- Lift carton off the generator.
- Remove all packing material, carton fillers, etc.
- Remove the generator from the shipping pallet.

## CARTON CONTENTS

Check all contents. If any parts are missing or damaged, call the generator helpline at **1-800-270-1408**. Contents include:

- 10,000 watt generator
- Generator owner's manual
- Engine owner's manual
- 2 Bottles of SAE 30 engine oil (28 oz.)
- Oil fill spout
- 125 Volt, 30 Amp plug
- 125 Volt, 20 Amp plug
- 120/240 Volt, 30 Amp plug
- Wheel kit

## CHECK BATTERY / ATTACH NEGATIVE BATTERY WIRE

The battery on the generator is fully charged, sealed and pre-installed except for the negative (black) battery cable.

### To install:

- Remove nut on the negative battery terminal.
- Slide the negative battery cable over the screw on the terminal (Figure 2).

Figure 2 — Negative Battery Connection

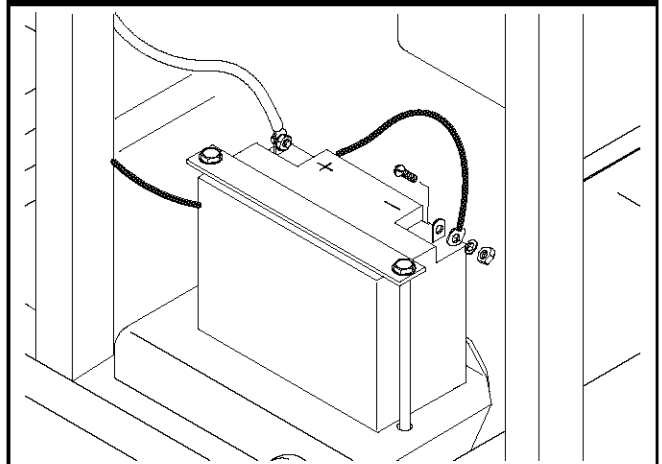

- Reattach nut and tighten.
- Ensure the connections to the battery and generator are tight and secure.

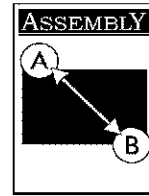

## WHEEL KIT INSTALLATION

You will need a 13mm metric box, open end or socket wrench to install this kit.

### Install Wheel Kit as follows: (Figure 3)

1. Place the bottom of the generator cradle on a flat, even surface. It may help to raise the cradle on temporary blocks.
2. Slide axle through both axle mounting brackets on cradle frame.
3. Slide spacer over each end of axle.
4. Install the wheel. Secure wheel on axle with retaining pin and washer. Be sure to install the wheel with the raised hub inboard.
5. Install other wheel in the same manner.
6. Secure the vibration mount on the support leg with lock nut, washer, and 30mm capscrew. Fasten the support leg to the bottom of the generator cradle, using 20mm capscrews, lock washers and flat washers.
7. Position the handle below the muffler bracket on the engine side of the generator. Attach the handle with 45mm capscrews and lock nuts.
8. Recheck all nuts to make sure they are tight and secure. Remove the temporary blocks.

Figure 3 — Wheel Kit

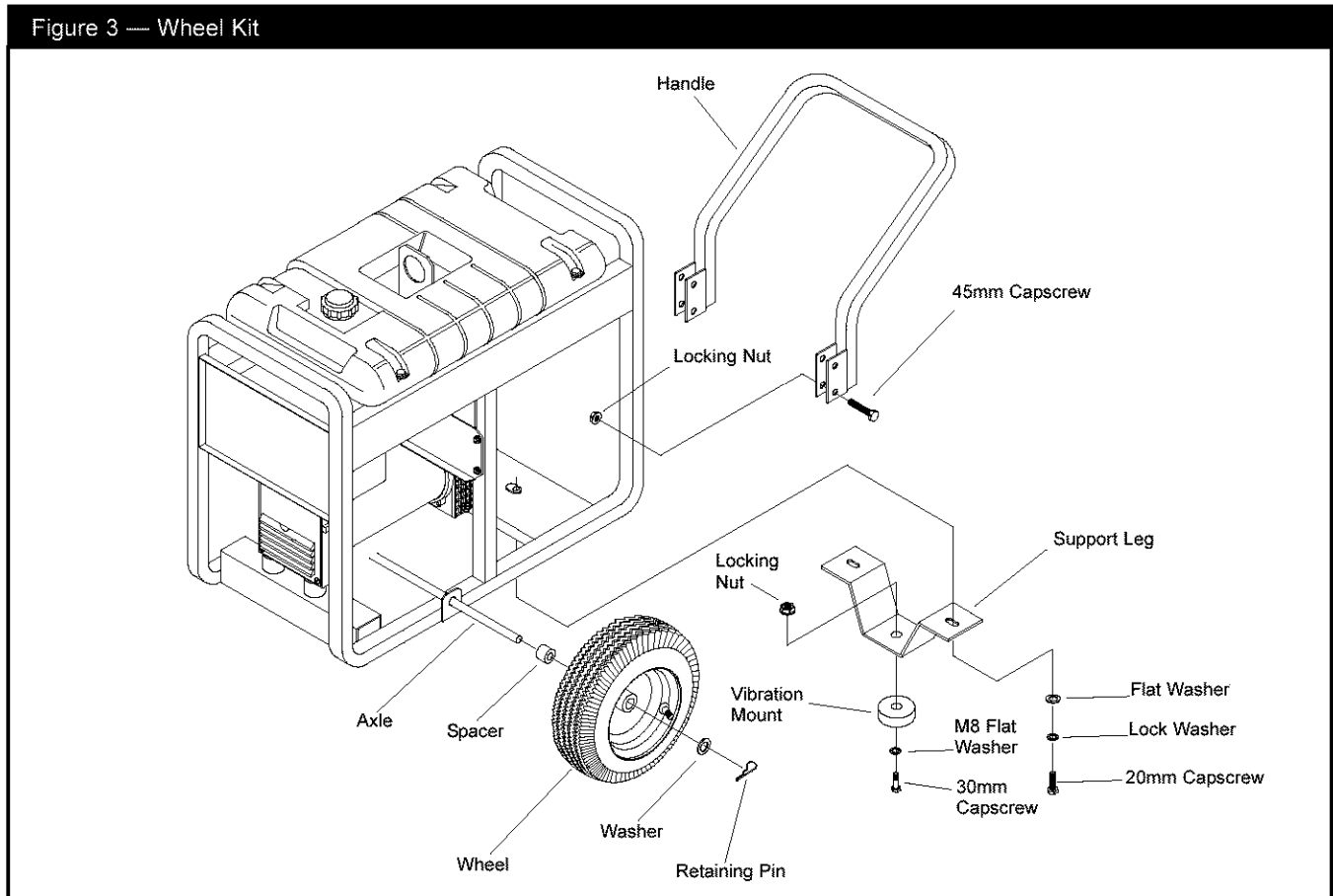



## KNOW YOUR GENERATOR

Read this owner's manual and safety rules before operating your generator.

Compare the illustrations with your generator to familiarize yourself with the locations of various controls and adjustments. Save this manual for future reference.

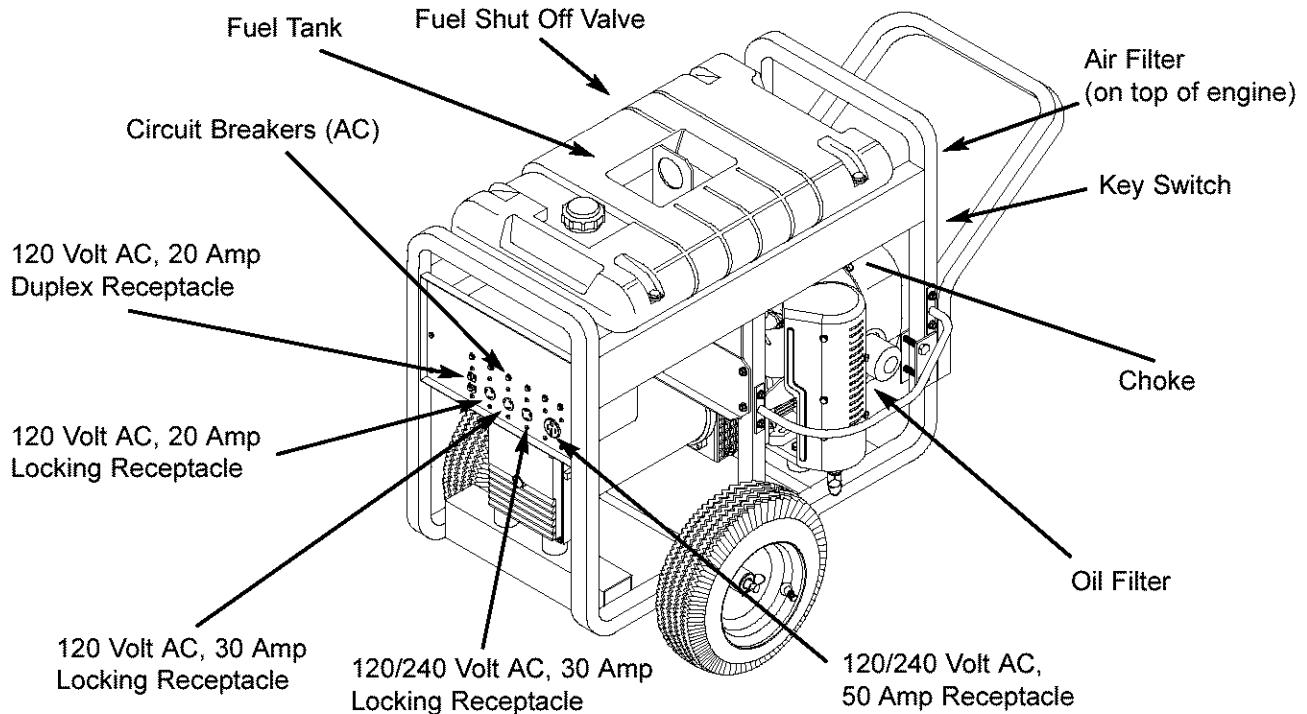

**120 Volt AC, 20 Amp Duplex Receptacle** — Each supplies electrical power for the operation of 120 Volt AC, 20 Amp, single phase, 60 Hz electrical lighting, appliance, tool and motor loads.

**120 Volt AC, 20 Amp Locking Receptacle** — Supplies electrical power for the operation of 120 Volt AC, 20 Amp, single phase, 60 Hz electrical lighting, appliance, tool and motor loads.

**120 Volt AC, 30 Amp Locking Receptacle** — Supplies electrical power for the operation of 120 Volt AC, 30 Amp, single phase, 60 Hz electrical lighting, appliance, tool and motor loads.

**120/240 Volt AC, 30 Amp Locking Receptacle** — Supplies electrical power for the operation of 120 and/or 240 Volt AC, 30 Amp, single phase, 60 Hz electrical lighting, appliance, tool and motor loads.

**120/240 Volt AC, 50 Amp Receptacle** — Supplies electrical power for the operation of 120/240 Volt AC, 50 Amp, single phase, 60 Hz welder or motor loads.

**Air Filter** — Filters intake air as it is drawn into the engine.

**Choke** — Used to start a cold engine.

**Circuit Breakers (AC)** — Each receptacle is provided with a circuit breaker to protect the generator against electrical overload. Breakers are "push to reset" type.

**Fuel Shut-Off Valve** — Always have the fuel shut-off valve closed when engine is not running.

**Fuel Tank** — Tank holds 10 U.S. gallons of unleaded gasoline.

**Key Switch** — Used to start engine. Always have key switch in the "Stop" position when not in use.

**Oil Filter** — Filters engine oil to prolong engine life.



## BEFORE STARTING THE GENERATOR

### Add Engine Oil

For your convenience, an oil filler spout has been supplied with your generator. This cap fits over a standard bottle of oil and allows for easy access to the oil fill.

See engine owner's manual for oil recommendations and fill instructions.

### Add Gasoline



**DANGER!** NEVER fill fuel tank indoors. NEVER fill fuel tank when engine is running or hot. DO NOT light a cigarette or smoke when filling the fuel tank.



**DANGER!** Do not overfill the fuel tank. Always leave room for expansion.

- Use **regular UNLEADED gasoline** in the generator. DO NOT use premium gasoline. DO NOT mix oil with gasoline. DO NOT overfill the gas tank.
- Clean area around fuel fill cap; remove cap.
- Fill fuel tank with clean, fresh, unleaded gasoline. Be careful not to overfill. Allow 1/2" of tank space for fuel expansion (Figure 4).

Figure 4 — Fuel Expansion Space

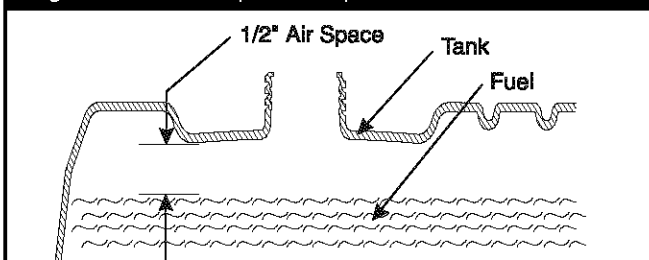

- Install fuel cap and wipe up any spilled gasoline.

**IMPORTANT:** It is important to prevent gum deposits from forming in essential fuel system parts such as the carburetor, fuel filter, fuel hose or tank during storage. Also, experience indicates that alcohol-blended fuels (called gasohol, ethanol or methanol)

can attract moisture, which leads to separation and formation of acids during storage. Acidic gas can damage the fuel system of an engine while in storage. To avoid engine problems, the fuel system should be emptied before storage of 30 days or longer. See "Storage" on page 12. Never use engine or carburetor cleaner products in the fuel tank or permanent damage may occur.

## TO START THE ENGINE



**WARNING!** Never start or stop engine with electrical devices plugged into the panel receptacles and turned on. You could damage both the generator and the electrical devices.

- Unplug all electrical loads from unit's receptacles before starting the engine.
- Make sure the unit is in a level position.
- Open the fuel shut-off valve (Figure 5).

Figure 5 — Fuel Shut-off Valve

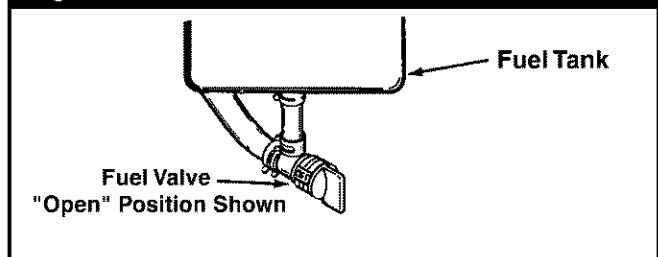

- Pull the choke knob to close. If the engine is warm, or the ambient temperature is high, pull the choke knob half-way, or keep it fully open (Figure 6).

Figure 6 — Choke Knob

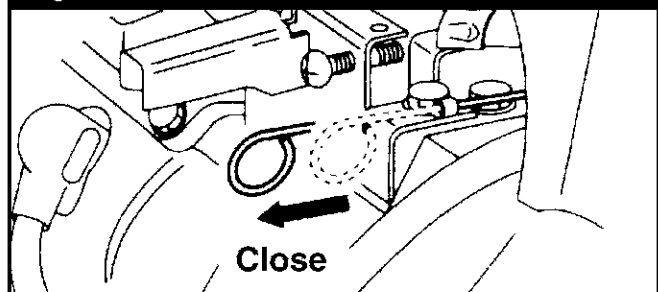



**DANGER!** Engine exhaust contains carbon monoxide, a colorless and odorless gas which causes unconsciousness and death. **Never run engine indoors or in poorly ventilated areas.**



**DANGER!** Burn hazard. Temperature of muffler and nearby areas may exceed 150°F (65°C). Do not touch these areas on the generator.

- Turn key switch to the “**Start**” position (Figure 7).

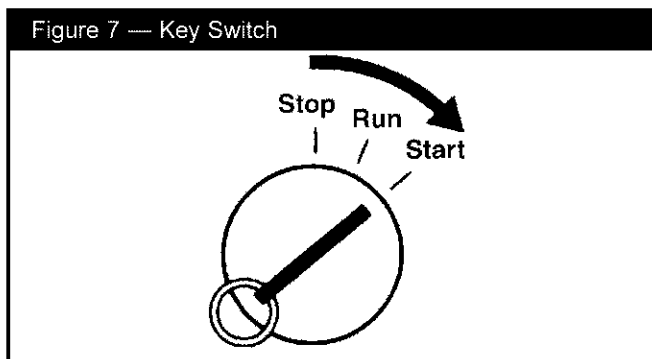

**IMPORTANT:** Do not operate the electric starter continuously for more than 5 seconds, even if the engine does not start. Extended cranking can damage the starter motor.

**NOTE:** If the engine fails to start, set the key to the “**Run**” position and wait for about 10 seconds before retrying.

**IMPORTANT:** Never turn the key switch to the “**Start**” position while the engine is running. You could damage the starter motor.

- When the engine starts, gradually open choke by pushing the choke knob in and keep it fully opened while running.

**IMPORTANT! Do not overload the generator! Do not overload individual panel receptacles!** These outlets are protected against overload with push-to-reset-type circuit breakers. If amperage rating of any circuit breaker is exceeded, that breaker opens and electrical output to that receptacle is lost. Read “Don’t Overload the Generator” on page 11 carefully.

### **If the Engine Will Not Start**

Refer to the engine owner’s manual.

## **STOPPING THE ENGINE**

- Remove all electrical loads connected to unit’s receptacles. **Never start or stop engine with devices plugged in and turned on.**
- Let engine run at no-load for 30 seconds to stabilize the unit’s internal temperatures.
- Turn the key switch to the “**Stop**” position.
- Close the fuel valve.

## **STOPPING THE ENGINE WITH THE FUEL VALVE**

This procedure eliminates fuel from the carburetor. Use this method to stop the generator if you plan to store the generator over a long period. Fuel will clog the internal passages of carburetor if allowed to remain for an extended period.

- Unplug all electrical loads connected to the unit’s receptacles. **Never start or stop engine with devices plugged in and turned on.**
- Let engine run at no-load for 30 seconds to stabilize the internal temperatures of engine and generator.
- Close the fuel valve while the engine is running and wait until the engine stops.
- Set the key switch to the “**Stop**” position after the engine quits.





## Connecting Electrical Loads

- DO NOT connect 240 Volt loads to 120 Volt receptacles.
- DO NOT connect 3-phase loads to the generator.
- DO NOT connect 50 Hz loads to the generator.
- Let engine stabilize and warm up for a few minutes after starting.
- Plug in and turn on the desired 120 Volt or 240 Volt, single phase, 60 Hz electrical loads.
- Add up the rated watts (or amps) of all loads to be connected at one time. This total should not be greater than (a) the rated wattage/ampere capacity of the generator or (b) circuit breaker rating of the receptacle supplying the power. See "Don't Overload the Generator" on page 11.

## RECEPTACLES

### 120 Volt AC, 20 Amp, Duplex Receptacle

Use each receptacle to power 120 Volt AC, single phase, 60 Hz electrical loads requiring up to a combined 2400 watts (2.4 kW) or 20 Amps of current (Figure 8).

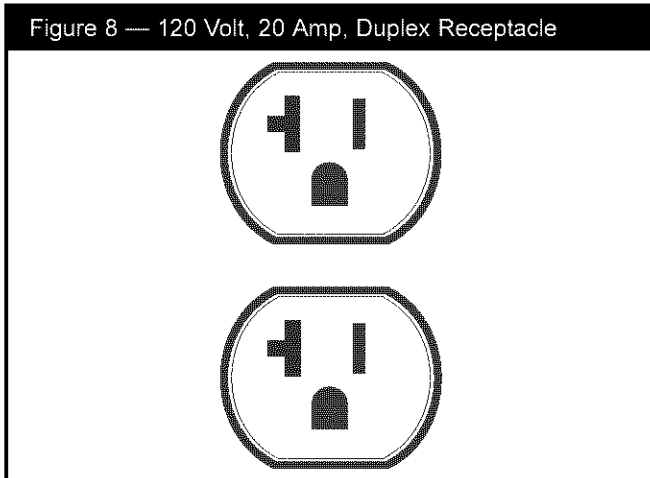

Each outlet is protected against overload by a 20 Amp push-to-reset circuit breaker. Use only high quality, well-insulated, 3-wire grounded cord sets rated for 125 Volts at 20 Amps (or greater).

### 120 Volt AC, 20 Amp Receptacle

Use a NEMA L5-20 plug with this receptacle. Connect a 3-wire cord set rated for 125 Volts AC at 20 Amps (or greater) to the plug (Figure 9).

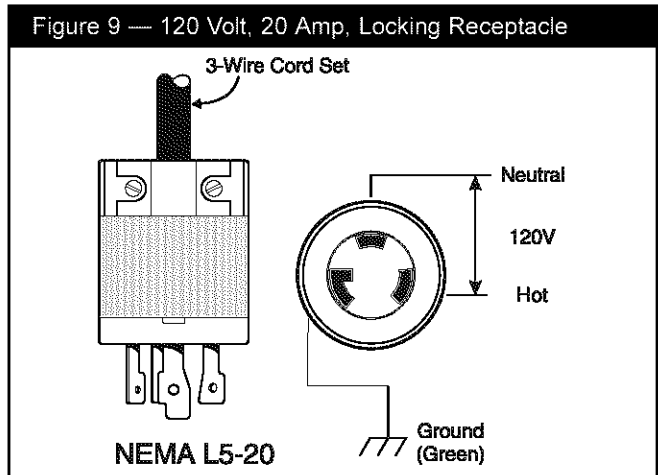

Use this receptacle to operate 120 Volt AC, 60 Hz, single phase loads requiring up to 2400 watts (2.4 kW) of power at 20 Amps. The outlet is protected by a 20 Amp push-to-reset circuit breaker.

### 120 Volt AC, 30 Amp Receptacle

Use a NEMA L5-30 plug with this receptacle. Connect a 3-wire cord set rated for 125 Volts AC at 30 Amps (or greater) to the plug (Figure 10).

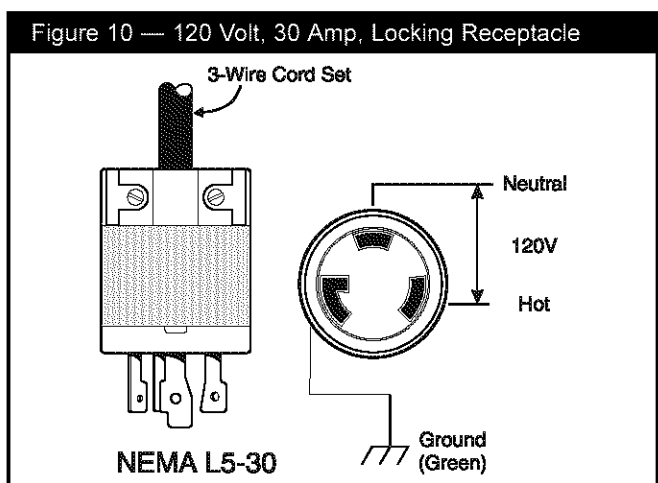



Use this receptacle to operate 120 Volt AC, 60 Hz, single phase loads requiring up to 3600 watts (3.6 kW) of power at 30 Amps. The outlet is protected by a 30 Amp push-to-reset circuit breaker.

### 120/240 Volt AC, 30 Amp Receptacle

Use a NEMA L14-30 plug with this receptacle. Connect a suitable 4-wire grounded cord set to the plug and to the desired load (Figure 11). The cord set should be rated for 250 Volts at 30 Amps (or greater).

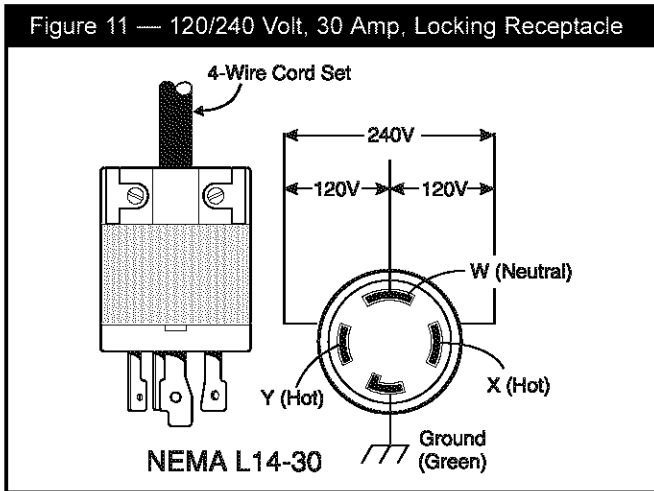

Use this receptacle to operate 120 Volt AC, 60 Hz, single phase loads requiring up to 3600 watts (3.6 kW) of power at 30 Amps or 240 Volt AC, 60 Hz, single phase loads requiring up to 7200 watts (7.2 kW) of power at 30 Amps. The outlet is protected by a 30 Amp push-to-reset circuit breaker.

### 240 Volt AC, 50 Amp Receptacle

Use a NEMA 14-50 plug with this receptacle. Connect a 4-wire cord set rated for 250 Volts at 50 Amps to the plug (Figure 12).

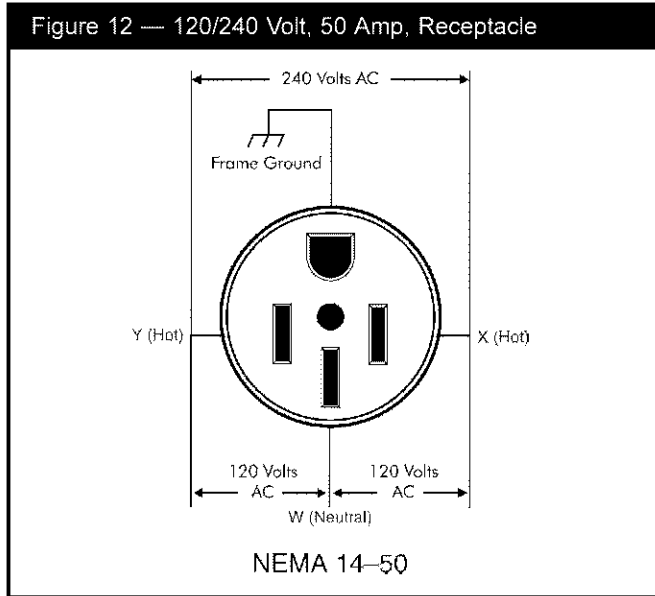

Use this receptacle to operate 240 Volt AC, 60 Hz, single phase loads requiring up to 10,000 watts (10.0 kW) of power.

**CAUTION!** Although this outlet states it has a 240 Volt AC, 50 Amp rating (up to 12,500 watts), the generator is only rated for 10,000 watts. Powering loads that exceed the wattage/ampere capacity of the generator can damage it and cause serious injuries.



## DON'T OVERLOAD THE GENERATOR

Overloading a generator in excess of its rated wattage capacity can result in damage to the generator and to connected electrical devices. Observe the following to prevent overloading the unit:

- Add up the total wattage of all electrical devices to be connected at one time. This total should NOT be greater than the generator's wattage capacity.
- The rated wattage of lights can be taken from light bulbs. The rated wattage of tools, appliances and motors can usually be found on a data plate or decal affixed to the device.

- If wattage is not given, multiply volts times ampere rating to determine watts (volts x amps = watts).
- Some electric motors, such as induction types, require about three times more watts of power for starting than for running. This power surge lasts only seconds when starting such motors. Make sure to allow for this high starting wattage when selecting electrical devices to connect to your generator:

1. Figure the watts needed to start the largest motor.
2. Add to that figure the running watts of all other connected loads.

The Wattage Reference Guide below (Figure 13) is provided to assist you in determining how many items your generator can operate at one time.

Figure 13 — Wattage Reference Guide

Device	Running Watts	Device	Running Watts
*Air Conditioner (12,000 Btu).....	1700	Hedge Trimmer.....	450
*Air Conditioner (24,000 Btu).....	3800	Impact Wrench.....	500
*Air Conditioner (40,000 Btu).....	6000	Iron.....	1200
Battery Charger (20 Amp).....	500	*Jet Pump.....	800
Belt Sander (3").....	1000	Lawn Mower.....	1200
Chain Saw.....	1200	Light Bulb.....	100
Circular Saw (6-1/2").....	800 to 1000	Microwave Oven.....	700 to 1000
*Clothes Dryer (Electric).....	5750	*Milk Cooler.....	1100
*Clothes Dryer (Gas).....	700	Oil Burner on Furnace.....	300
*Clothes Washer.....	1150	Oil Fired Space Heater (140,000 Btu).....	400
Coffee Maker.....	1750	Oil Fired Space Heater (85,000 Btu).....	225
*Compressor (1 HP).....	2000	Oil Fired Space Heater (30,000 Btu).....	150
*Compressor (3/4 HP).....	1800	*Paint Sprayer, Airless (1/3 HP).....	600
*Compressor (1/2 HP).....	1400	Paint Sprayer, Airless (handheld).....	150
Curling Iron.....	700	Radio.....	50 to 200
*Freezer.....	700	*Refrigerator.....	700
*Dehumidifier.....	650	Slow Cooker.....	200
Disc Sander (9").....	1200	*Submersible Pump (1-1/2 HP).....	2800
Edge Trimmer.....	500	*Submersible Pump (1 HP).....	2000
Electric Blanket.....	400	*Submersible Pump (1/2 HP).....	1500
Electric Nail Gun.....	1200	*Sump Pump.....	800 to 1050
Electric Range (per element).....	1500	*Table Saw (10").....	1750 to 2000
Electric Skillet.....	1250	Television.....	200 to 500
*Furnace Fan (3/5 HP).....	875	Toaster.....	1000 to 1650
*Garage Door Opener.....	500 to 750	Weed Trimmer.....	500
Hair Dryer.....	1200		
Hand Drill.....	250 to 1100		

\* Allow 3 times the listed watts for starting these devices.



# GENERAL MAINTENANCE RECOMMENDATIONS

The Owner/Operator is responsible for making sure that all periodic maintenance tasks are completed on a timely basis; that all discrepancies are corrected; and that the unit is kept clean and properly stored. **Never operate a damaged or defective generator.**

## Engine Maintenance

See your engine owner's manual for instructions.

## Generator Maintenance

Generator maintenance consists of keeping the unit clean and dry. Operate and store the unit in a clean dry environment where it will not be exposed to excessive dust, dirt, moisture or any corrosive vapors. Make sure the cooling air slots in the generator do not become clogged with leaves or other foreign material.

**NOTE: DO NOT** use a garden hose to clean generator. Water can enter the engine fuel system and cause problems. In addition, if water enters the generator through the cooling air slots, some water will be retained in the voids and cracks of the rotor and stator winding insulation. Water and dirt buildup on the generator internal windings will eventually decrease the insulation resistance of these windings.

## To Clean the Generator

- Use a damp cloth to wipe exterior surfaces clean.
- Soft, bristle brush may be used to loosen caked on dirt or oil.
- A vacuum cleaner may be used to pick up loose dirt and debris.
- Low pressure air (not to exceed 25 psi) may be used to blow away dirt. Inspect cooling air slots and opening on generator. These openings must be kept clean and unobstructed.

## STORAGE

The generator should be started at least once every seven days and allowed to run at least 30 minutes. If this cannot be done and you must store the unit for

more than 30 days, use the following guidelines to prepare it for storage.

## Generator Storage

- Clean the generator as outlined in "To Clean the Generator."
- Check that the cooling air slots and openings on the generator are open and unobstructed.
- Remove the negative battery cable from the battery to prevent the battery from being depleted.



**DANGER!** The battery is water based. If you are storing the generator in an area that will go below freezing, you must remove the battery and store it separately in an area that will not freeze. If you allow the battery to freeze, the water in it will expand and crack open the battery spilling the contents.

- Prepare the engine in accordance with the storage instructions in the engine owner manual.
- Let the unit completely cool for at least 5 minutes before placing any cover over the unit.
- Store the unit in a clean dry place.

## Other Storage Tips

- Do not store gasoline from one season to another.
- Replace your gasoline can if it starts to rust. Rust and/or dirt in a gasoline can cause problems when you use that fuel with this unit.
- Store in clean and dry area.

## SPECIFICATIONS

Rated Maximum Continuous AC Power Output.....	10,000 Watts
Rated Voltage .....	120/240 Volts
Rated Maximum Current at 240 Volts .....	41.6 Amps
Rated Maximum Current at 120 Volts .....	83.3 Amps
Phase.....	1
Rated AC Frequency .....	60 Hertz
Number of Rotor Poles .....	2
Driven Speed of Rotor .....	3600 rpm





## TROUBLESHOOTING

<b>Problem</b>	<b>Cause</b>	<b>Solution</b>
<b>Engine is running, but no AC output is available.</b>	<ol style="list-style-type: none"><li>1. Circuit breaker is open.</li><li>2. Poor connection or defective cord set.</li><li>3. Connected device is bad.</li><li>4. Fault in generator.</li></ol>	<ol style="list-style-type: none"><li>1. Reset circuit breaker.</li><li>2. Check and repair.</li><li>3. Connect another device that is in good condition.</li><li>4. Contact Generac service facility.</li></ol>
<b>Engine runs good but bogs down when loads are connected.</b>	<ol style="list-style-type: none"><li>1. Short circuit in a connected load.</li><li>2. Generator is overloaded.</li><li>3. Engine speed is too slow.</li><li>4. Shorted generator circuit.</li></ol>	<ol style="list-style-type: none"><li>1. Disconnect shorted electrical load.</li><li>2. See "Don't Overload the Generator" on page 11.</li><li>3. Contact Robin service facility.</li><li>4. Contact Generac service facility.</li></ol>
<b>Engine will not start; or starts and runs rough.</b>	<ol style="list-style-type: none"><li>1. Dirty air cleaner.</li><li>2. Out of gasoline.</li><li>3. Stale gasoline.</li><li>4. Spark plug wire not connected to spark plug.</li><li>5. Bad spark plug.</li><li>6. Water in gasoline.</li><li>7. Overchoking.</li><li>8. Low oil level.</li><li>9. Excessively rich fuel mixture.</li><li>10. Intake valve stuck open or closed.</li><li>11. Engine has lost compression.</li></ol>	<ol style="list-style-type: none"><li>1. Clean or replace air cleaner.</li><li>2. Fill fuel tank.</li><li>3. Drain gas tank and fill with fresh fuel.</li><li>4. Connect wire to spark plug.</li><li>5. Replace spark plug.</li><li>6. Drain gas tank; fill with fresh fuel.</li><li>7. Put choke lever to "no choke" position.</li><li>8. Fill crankcase to proper level.</li><li>9. Contact Robin service facility.</li><li>10. Contact Robin service facility.</li><li>11. Contact Robin service facility.</li></ol>
<b>Engine shuts down during operation.</b>	<ol style="list-style-type: none"><li>1. Out of gasoline.</li><li>2. Low oil level.</li><li>3. Fault in engine.</li></ol>	<ol style="list-style-type: none"><li>1. Fill fuel tank.</li><li>2. Fill crankcase to proper level.</li><li>3. Contact Robin service facility.</li></ol>
<b>Engine lacks power.</b>	<ol style="list-style-type: none"><li>1. Load is too high.</li><li>2. Dirty air filter.</li><li>3. Engine needs to be serviced.</li></ol>	<ol style="list-style-type: none"><li>1. See "Don't Overload the Generator" on page 11.</li><li>2. Replace air filter.</li><li>3. Contact Robin service facility.</li></ol>
<b>Engine "hunts" or falters.</b>	<ol style="list-style-type: none"><li>1. Choke is opened too soon.</li><li>2. Carburetor is running too rich or too lean.</li></ol>	<ol style="list-style-type: none"><li>1. Move choke to halfway position till engine runs smoothly.</li><li>2. Contact Robin service facility.</li></ol>





# SCHEMATIC DIAGRAM

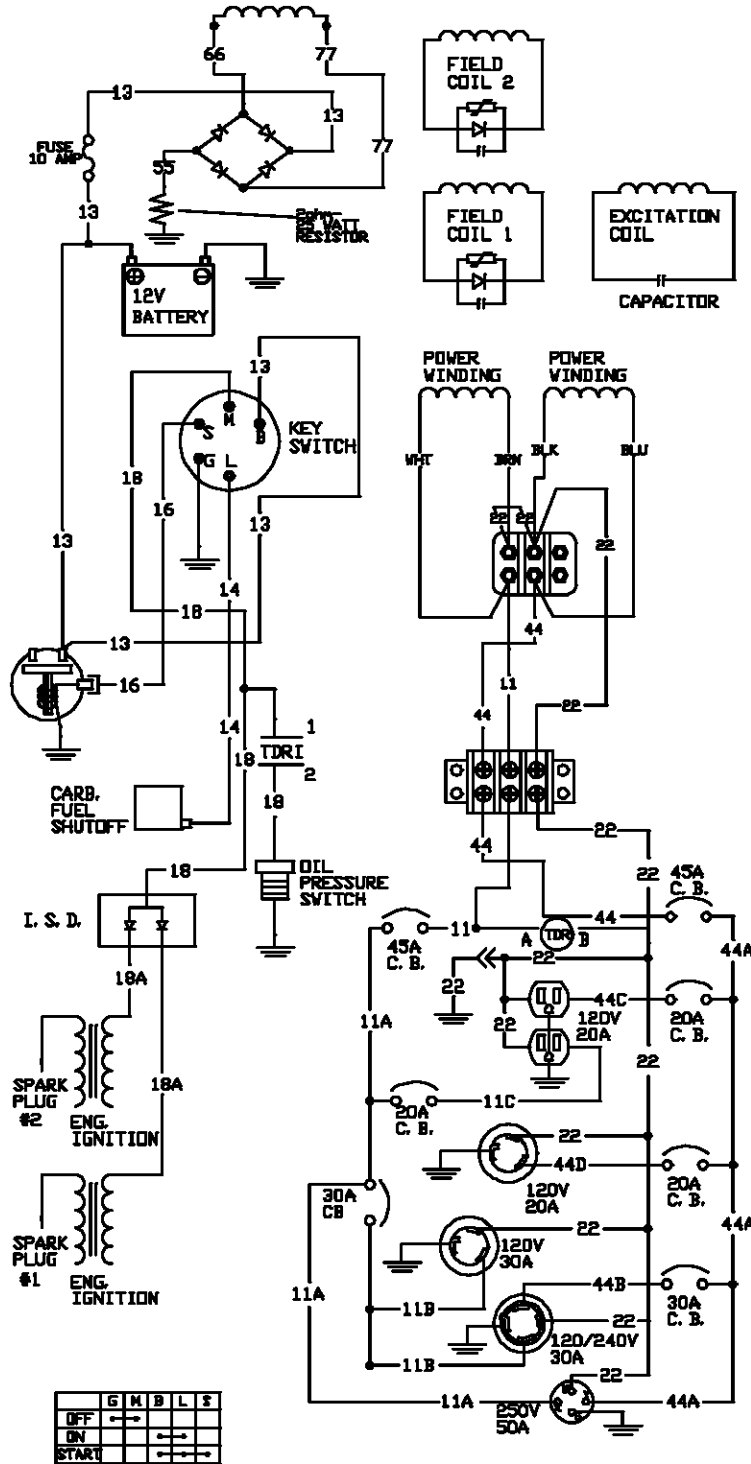

	G	M	B	L	F
OFF	→	→	→	→	→
ON	→	→	→	→	→
START	→	→	→	→	→



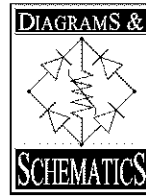

# WIRING DIAGRAM

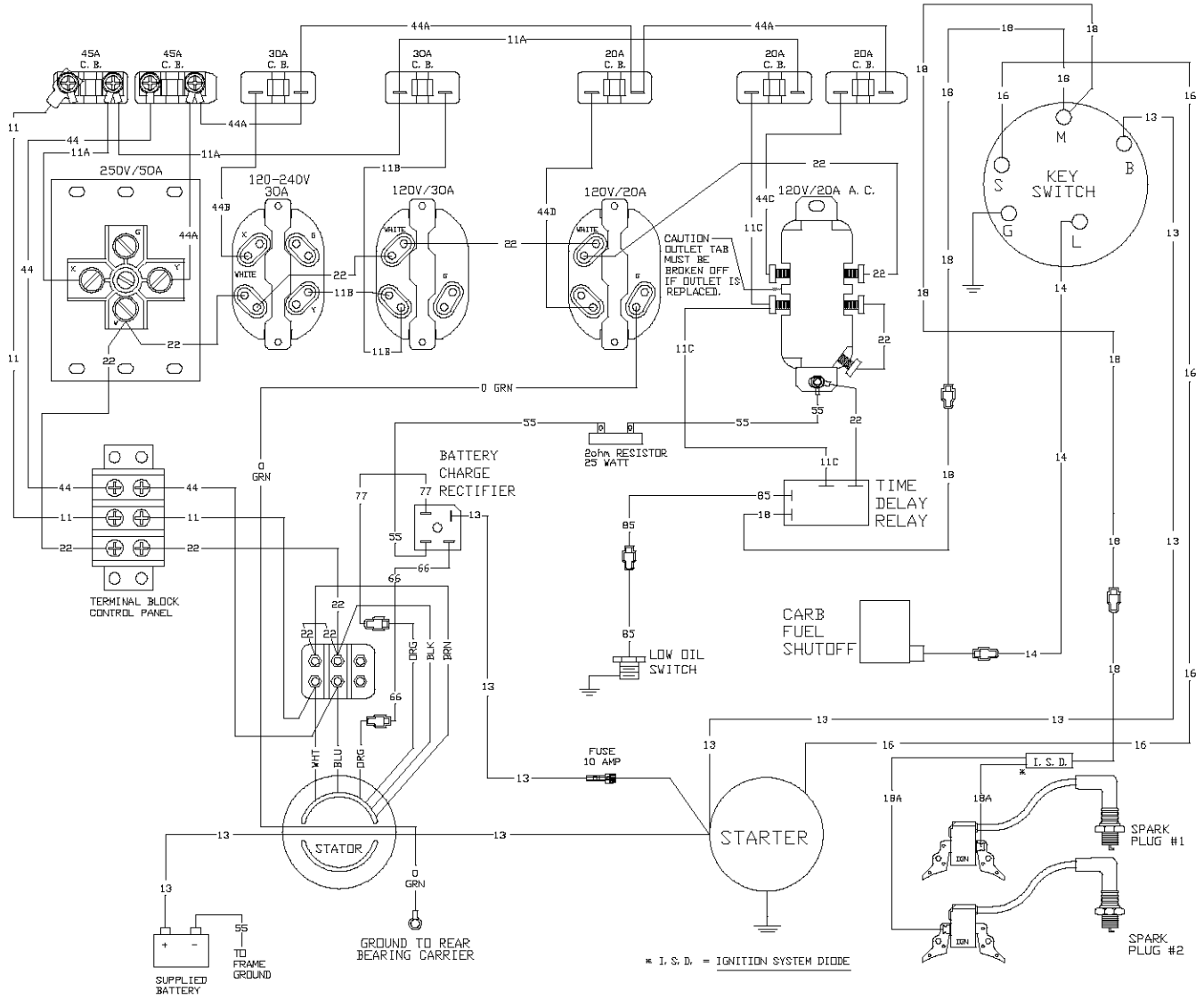

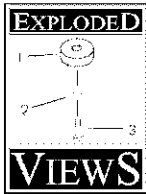

# GENERATOR EXPLODED VIEW

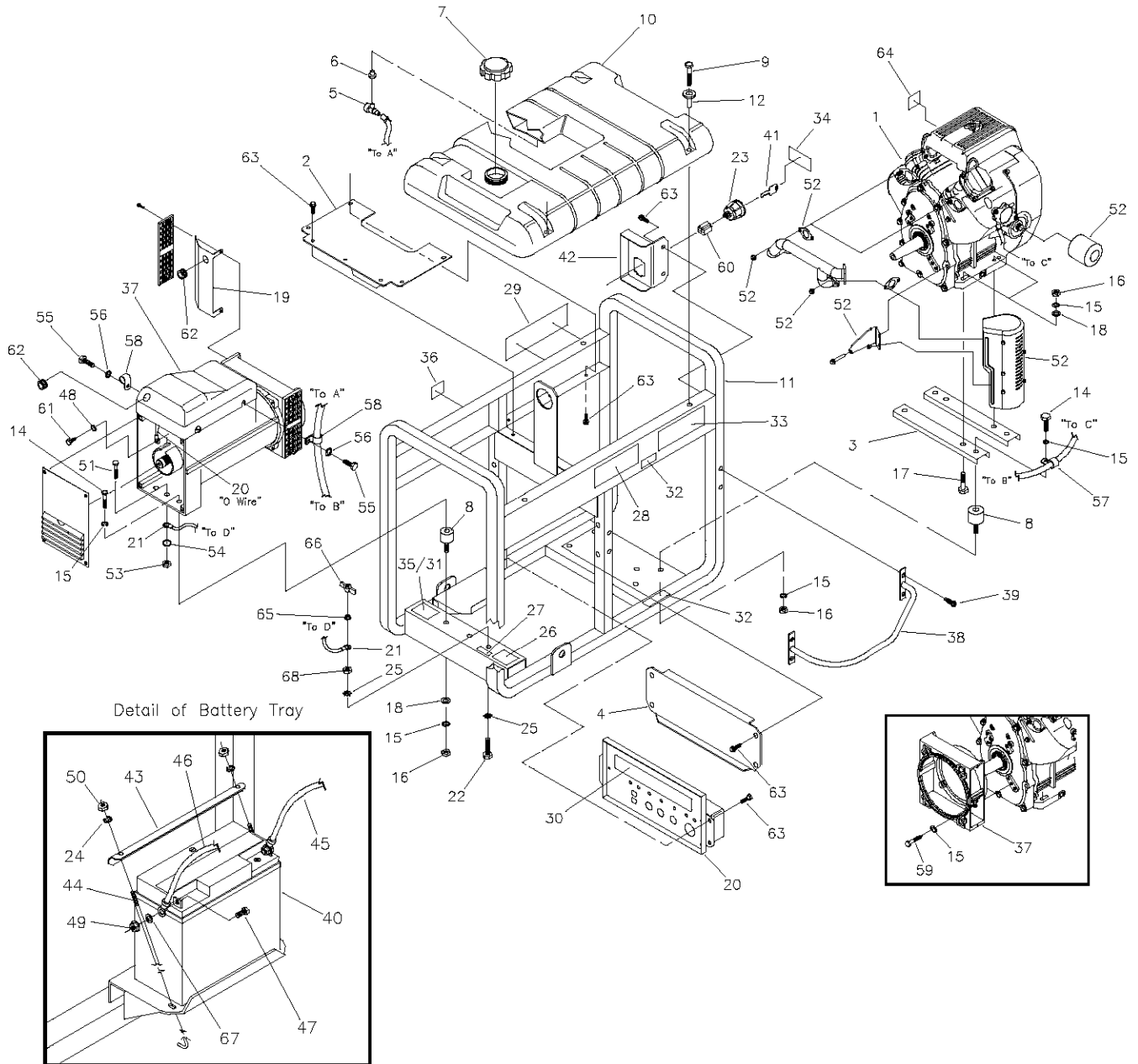

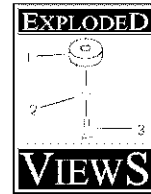

## GENERATOR PARTS LIST

Item	Part #	Qty	Description	Item	Part #	Qty	Description
1	NSP	1	ENGINE, Robin 18HP	41	B4627	1	KEY, Ignition Switch
2	BB4509	1	SHIELD, Heat	42	AB4682	1	BRACKET, Ignition Switch
3	A77304	2	SUPPORT, Engine	43	A96925	1	BRACKET, Battery Tie Down
4	BB4811	1	SHIELD, Heat	44	96924	2	J-BOLT, M8 - 1.25
5	80270	1	VALVE, Fuel Shut-Off	45	193-53621	1	CABLE, Battery Positive
6	78299	1	BUSHING, Fuel Valve	46	194-53621	1	CABLE, Battery Negative
7	B4325	1	CAP, Fuel Tank	47	52618	2	HHCS, M5 - 0.8 x 12
8	38353	6	MOUNTS, Vibration	48	49226	1	WASHER, M5 Lock
9	78831B	4	CAPSCREW, M6-1.0 x 60mm	49	52856	2	NUT, M5 Flange Lock
10	B1696	1	TANK, Fuel 10 Gal	50	49820	2	NUT, Nylok M8 - 1.25
11	AB4426	1	CRADLE	51	39253	1	CAPSCREW, M8 - 1.25 x 20
12	83465	4	GROMMET, Mounting	52	NSP		SUPPLIED WITH ENGINE
14	23152	7	CAPSCREW, 3/8-16 x 3/4"	53	45771	1	NUT, M8 - 1.25
15	22237	20	WASHER, 3/8" Lock	54	27482	1	WASHER, 5/16" Shakeproof
16	22241	10	NUT, 3/8"-16 Hex	55	47411	2	CAPSCREW, M6 - 1.0 X 16
17	22746	4	CAPSCREW, 3/8-16 x 1-3/4"	56	22473	2	WASHER, Flat M6
18	22131	8	WASHER, 3/8" Flat	57	B4948	1	CLAMP, Hose
19	BB5117	1	SHIELD, Heat	58	55934G	2	CLAMP, Hose
20	B4425	1	ASSEMBLY, Control Panel	59	22511	4	CAPSCREW, 3/8 x 1-1/4"
21	195-53621	1	WIRE ASSEMBLY, Ground	60	B4803	1	CONNECTOR, 5-way
22	38750	1	HHCS, M6 - 1.0 x 30	61	52618	1	HHCS, M5 - 0.8 x 12
23	B4502	1	SWITCH, Key Ignition	62	B4794	2	GROMMET, Generator Cover
24	22145	2	WASHER, M8 Flat	63	B2153	17	SCREW, #12 Self Driller
25	26850	3	WASHER, M6 Shakeproof	64	B4988	1	DECAL, Oil Fill
26	20566	1	DECAL, 1-800	65	52857	1	NUT, Locking M6 - 1.0
27	B4986	1	DECAL, Ground	66	87680	1	WING NUT, M6 - 1.0
28	92982	1	DECAL, Danger	67	23897	2	WASHER, M5 Lock
29	B4865	1	DECAL, Side Panel	68	49813	1	NUT Hex M6 - 1.0
30	B4866	1	DECAL, Control Panel				
31	78817	1	DECAL, Data Plate				
32	77816	2	DECAL, Caution Hot Muffler	<b>Items Not Illustrated:</b>			
33	B4826	1	DECAL, Start Instructions	BB3061	2	SAE 30 Oil	
34	B4824	1	DECAL, Start - Run - Stop	B3518	1	Oil Bottle Funnel	
35	79552	1	DECAL, Overlamine	37806	1	125 Volt 30 Amp Plug	
36	73054	1	DECAL, Fuel Shut-Off	43438	1	240 Volt 30 Amp Plug	
37	B4268	1	ALTERNATOR, 10KW	93568	1	125 Volt 20 Amp Plug	
38	BB4481	1	GUARD, Muffler	B4472	1	Owner's Manual	
39	20441	4	SCREW, 1/4" x 3/4" Self Driller	B4888	1	Generator Reference Card	
40	B4489	1	BATTERY	NA	1	Engine Owner's Manual	

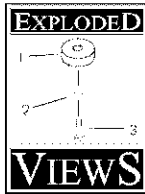

## ALTERNATOR EXPLODED VIEW AND PARTS LIST

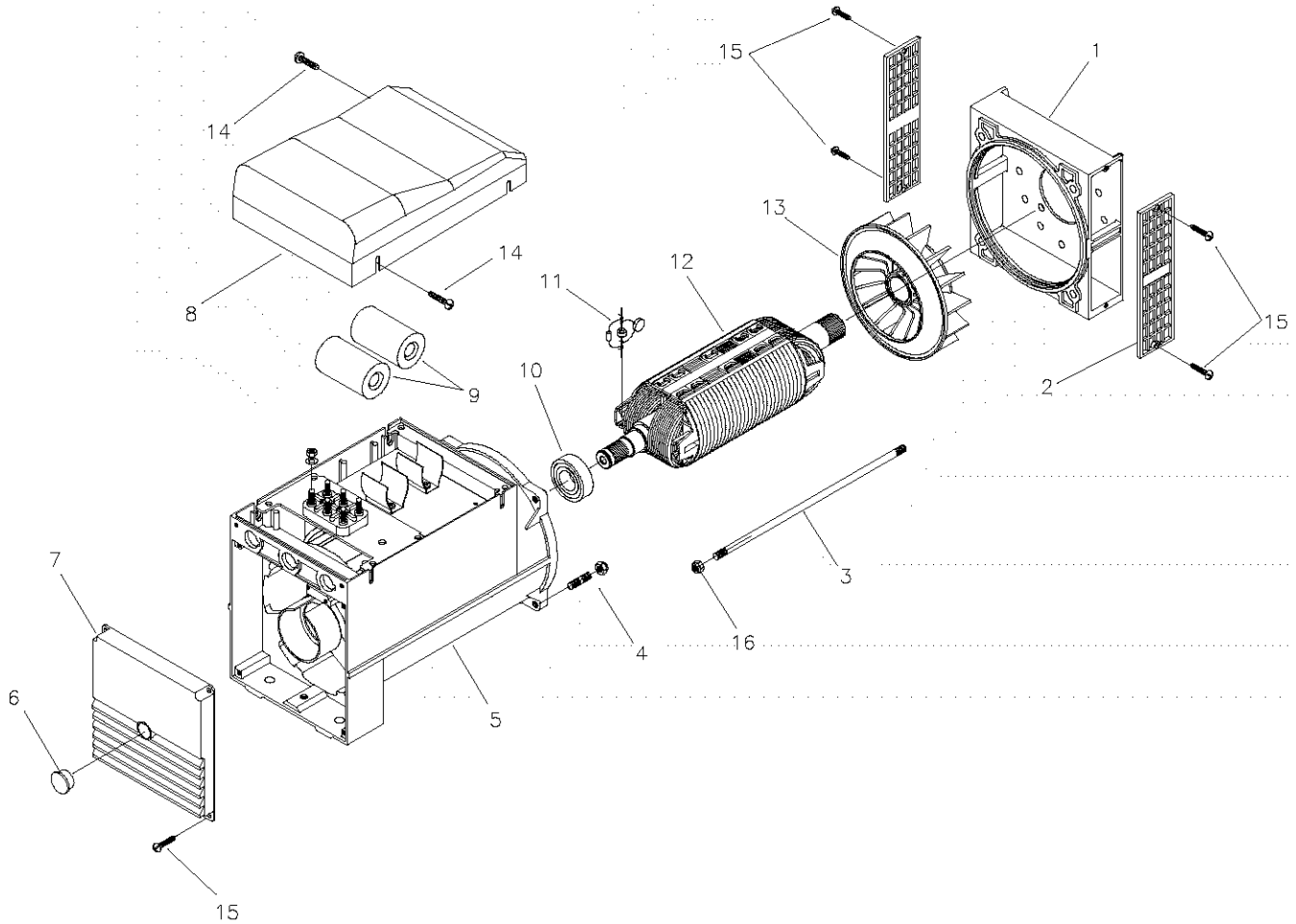

Item	Part #	Qty	Description	Item	Part #	Qty	Description
1	B4906	1	SHIELD, Front	10	B4915	1	BEARING, 62052RS C3
2	B4907	2	GRID, Front	11	B4916	1	CAPACITOR, Diode + Varistor + EMC
3	B4908	1	BOLT, Shaft Stay	12	B4917	1	ROTOR, (Includes Item 13)
4	B4909	4	STAY BOLT, M8 x 30	13	B4918	1	FAN
5	B4910	1	ASSEMBLY, Housing	14	B4919	2	SCREW, M6 - 1.0 x 10mm
6	B4911	1	CAP	15	B4920	8	SCREW, M5 - 0.8 x 10mm
7	B4912	1	COVER, Blind End	16	49820	1	LOCK NUT, M8 - 1.25
8	B4913	1	COVER, Top Black				
9	B4914	2	CAPACITOR, 25mF 450V				

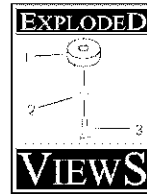

# CONTROL PANEL EXPLODED VIEW AND PARTS LIST

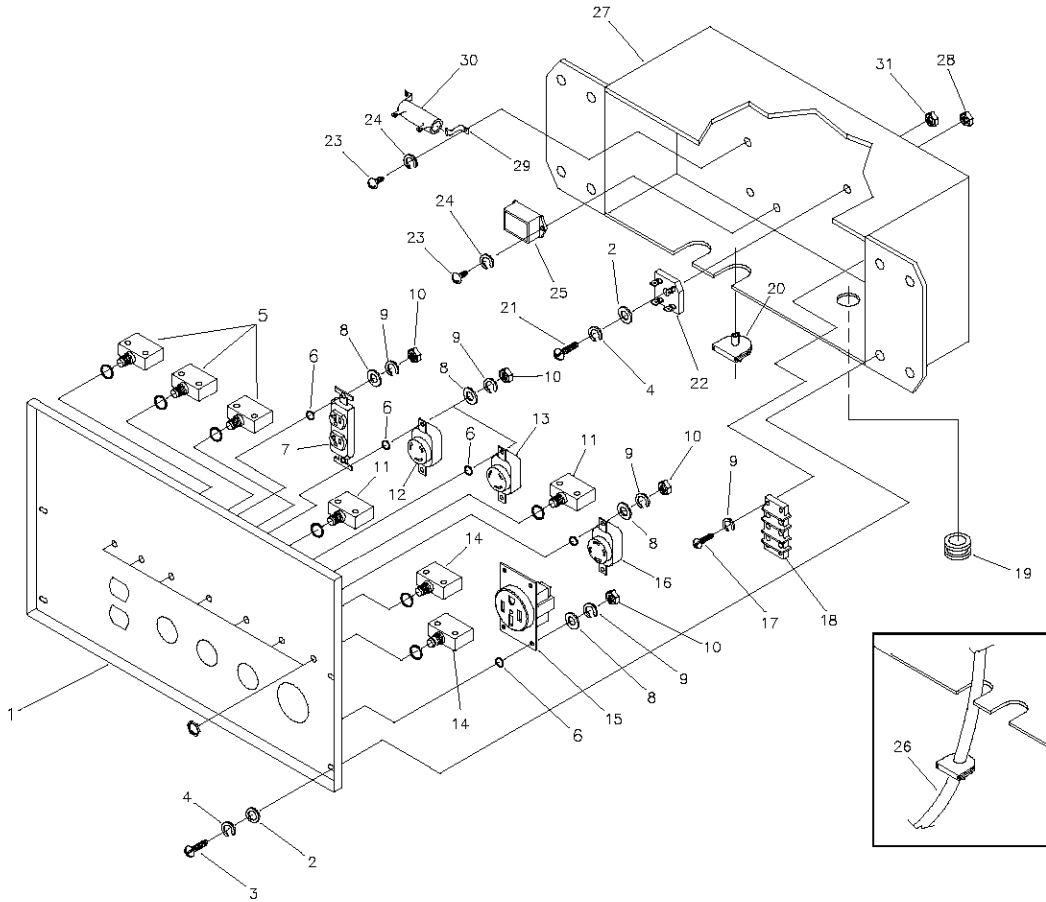

Item	Part #	Qty	Description	Item	Part #	Qty	Description
1	BB4504	1	PANEL, Control	16	43437	1	OUTLET, 120/240V, 30 Amp Locking
2	23897	5	FLAT WASHER, #10 - M5	17	80077	4	PPHMS, M4 x 20mm
3	91526	4	PPHMS, M5 - .08 x 12mm	18	92953	1	BLOCK, 50 Amp, 3 - Terminal
4	49226	5	LOCK WASHER, M5	19	90576	1	GROMMET, Rubber
5	75207	3	CIRCUIT BREAKER, 20 Amp	20	84135	1	GROMMET, Rubber
6	23365	12	WASHER, #8 Shakeproof	21	75477	1	PPHMS, M5 - 0.8 x 20mm
7	68759	1	OUTLET, 120V, 20 Amp Duplex	22	B4894	1	RECTIFIER, Battery Charge
8	38150	12	FLAT WASHER, #8	23	43181	4	PHMS, M3 - 0.5 x 10mm
9	22264	12	LOCK WASHER, #8	24	43182	4	LOCK WASHER, M3
10	51715	12	NUT, M4 - 0.7 Hex	25	77314	1	RELAY, Thermal
11	75207A	2	CIRCUIT BREAKER, 30 Amp	26	B4737	1	ASSEMBLY, Wire Harness
12	74190	1	OUTLET, 120V/20A Locking	27	B95906	1	BOX, Control Panel
13	68868	1	OUTLET, 120V, 30 Amp Locking	28	51716	1	NUT, Hex M5 - 0.8
14	B4445	2	CIRCUIT BREAKER, 45 Amp	29	B4893	2	STAND OFF
15	B4262	1	OUTLET, 120/250V, 50 Amp	30	B4892	1	RESISTOR, 2ohm 25 watt
				31	51714	1	NUT, Hex M3

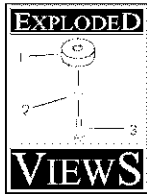

## WHEEL KIT EXPLODED VIEW AND PARTS LIST

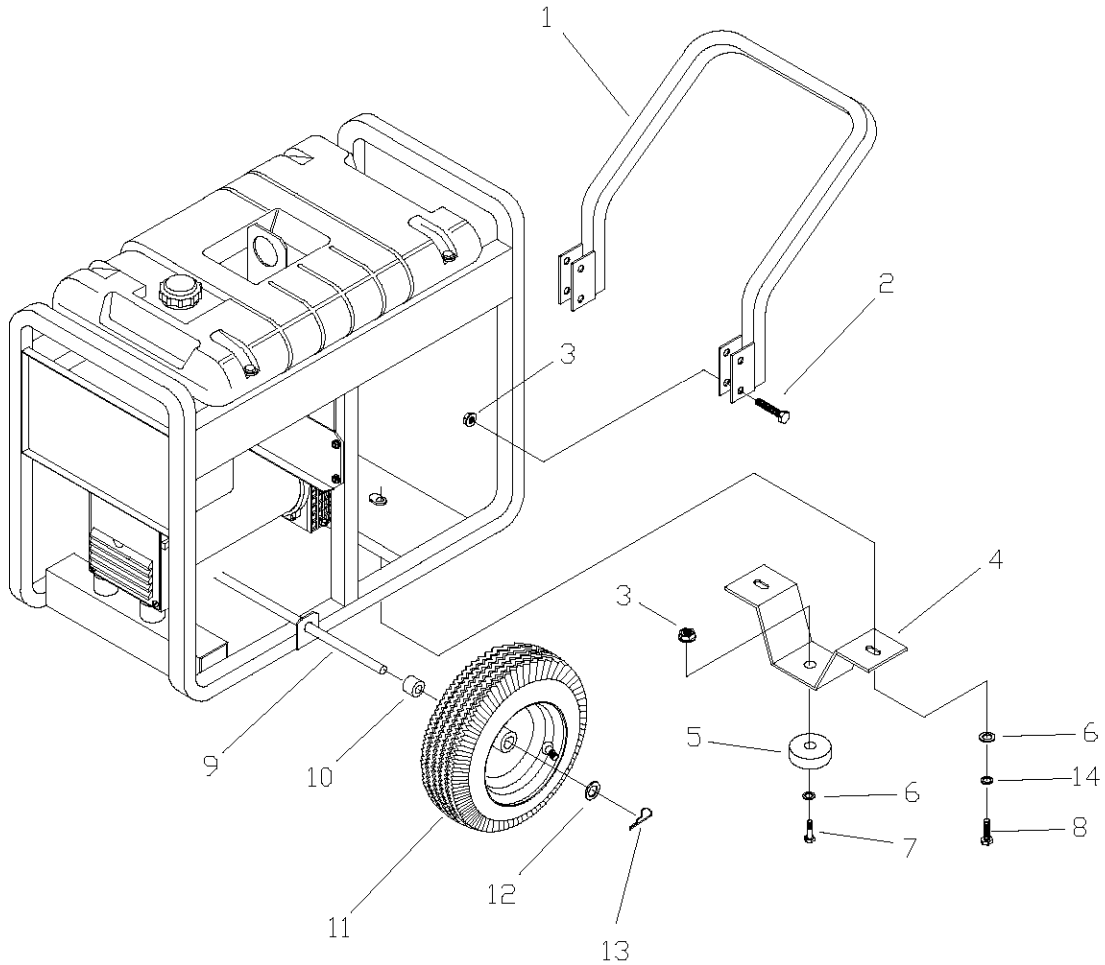

Item	Part #	Qty	Description
1	93393B	1	HANDLE
2	39287	4	HHCS, M8 - 1.25 x 45mm
3	52858	5	NUT, Locking M8 - 1.25
4	93394	1	LEG, Mounting Support
5	27007	1	MOUNT, Vibration
6	22145	3	FLAT WASHER, 5/16 - M8
7	42909	1	HHCS, M8 - 1.25 x 30mm
8	39253	2	HHCS, M8 - 1.25 x 20mm
9	93693B	1	AXLE
10	89635	2	SPACER, Wheel
11	89742	2	WHEEL
12	22247	2	WASHER, Wheel
13	87005	2	PIN, Retaining
14	22129	2	WASHER, M8 Lock



# LIMITED WARRANTY

## FOR OVERHEAD VALVE V-TWIN ENGINE-DRIVEN PORTABLE GENERATORS

GENERAC PORTABLE PRODUCTS (hereafter referred to as the COMPANY) warrants to the original purchaser that all components originally equipped with the generator, excluding the engine, for its portable generator will be free from defects in materials or workmanship for the items and period set forth below from the date of original purchase. This warranty is not transferable and applies only to portable generators driven by an overhead valve V-Twin engine.

	Consumer*	Commercial*
Alternator	2 years (2nd year parts only)	1 year
Engine	Warranted solely by the engine manufacturer	

***With the exception of European Community Countries, all units bound for export shall be warranted for One (1) Year in Consumer applications, and 90 days in Commercial applications as defined below.***

**\*NOTE: For the purpose of this warranty "consumer use" means personal residential household use by original purchaser. This warranty does not apply to units used for Prime Power in place of utility. "Commercial Use" means all other uses, including rental, construction, commercial and income producing purposes. Once a generator has experienced commercial use, it shall thereafter be considered a commercial use generator for the purposes of this warranty.**

During said warranty period, the COMPANY will, at its option, repair or replace any part which, upon examination by the COMPANY, is found to be defective under normal use and service\*\*. Starting batteries are not warranted by the COMPANY. All transportation costs under warranty, including return to the factory if necessary, are to be borne by the purchaser and prepaid by the purchaser. This warranty does not cover normal maintenance and service and does not apply to a generator set, alternator, or parts which have been subjected to improper or unauthorized installation or alteration, misuse, negligence, accident, overloading, overspeeding, improper maintenance, repair or storage so as, in the COMPANY's judgement, to adversely affect its performance and reliability.

**\*\*NORMAL WEAR: As with all mechanical devices, the generator needs periodic parts service and replacement to perform well. This warranty will not cover repair when normal use has exhausted the life of a part or generator.**

THERE IS NO OTHER EXPRESS WARRANTY. THE COMPANY HEREBY DISCLAIMS ANY AND ALL IMPLIED WARRANTIES, INCLUDING BUT NOT LIMITED TO THOSE OF MERCHANTABILITY AND FITNESS FOR A PARTICULAR PURPOSE TO THE EXTENT PERMITTED BY LAW. THE DURATION OF ANY IMPLIED WARRANTIES WHICH CANNOT BE DISCLAIMED IS LIMITED TO THE TIME PERIOD AS SPECIFIED IN THE EXPRESS WARRANTY. LIABILITY FOR CONSEQUENTIAL, INCIDENTAL OR SPECIAL DAMAGES UNDER ANY AND ALL WARRANTIES IS EXCLUDED. THE COMPANY ALSO DISCLAIMS ANY RESPONSIBILITY FOR INCIDENTAL OR CONSEQUENTIAL DAMAGES, SUCH AS THE LOSS OF TIME OR THE USE OF THE POWER EQUIPMENT, OR ANY COMMERCIAL LOSS DUE TO THE FAILURE OF THE EQUIPMENT: AND ANY IMPLIED WARRANTIES ARE LIMITED TO THE DURATION OF THIS WRITTEN WARRANTY.

Some states do not allow limitations on how long an implied warranty lasts, or the exclusion or limitation of incidental or consequential damages, so the above limitations or exclusions may not apply to you. This warranty gives you specific legal rights and you may also have other rights, which vary from state to state.

For service, see your nearest COMPANY authorized warranty service facility or call 1-877-544-0982. Warranty service can be performed only by a COMPANY authorized service facility. This warranty will not apply to service at any other facility. At the time of requesting warranty service, evidence of original purchase date must be presented.

**GENERAC PORTABLE PRODUCTS**  
Jefferson, Wisconsin 53549