

GENERAC[®]
Portable Products

7500EXL

Portable Generator Owner's Manual

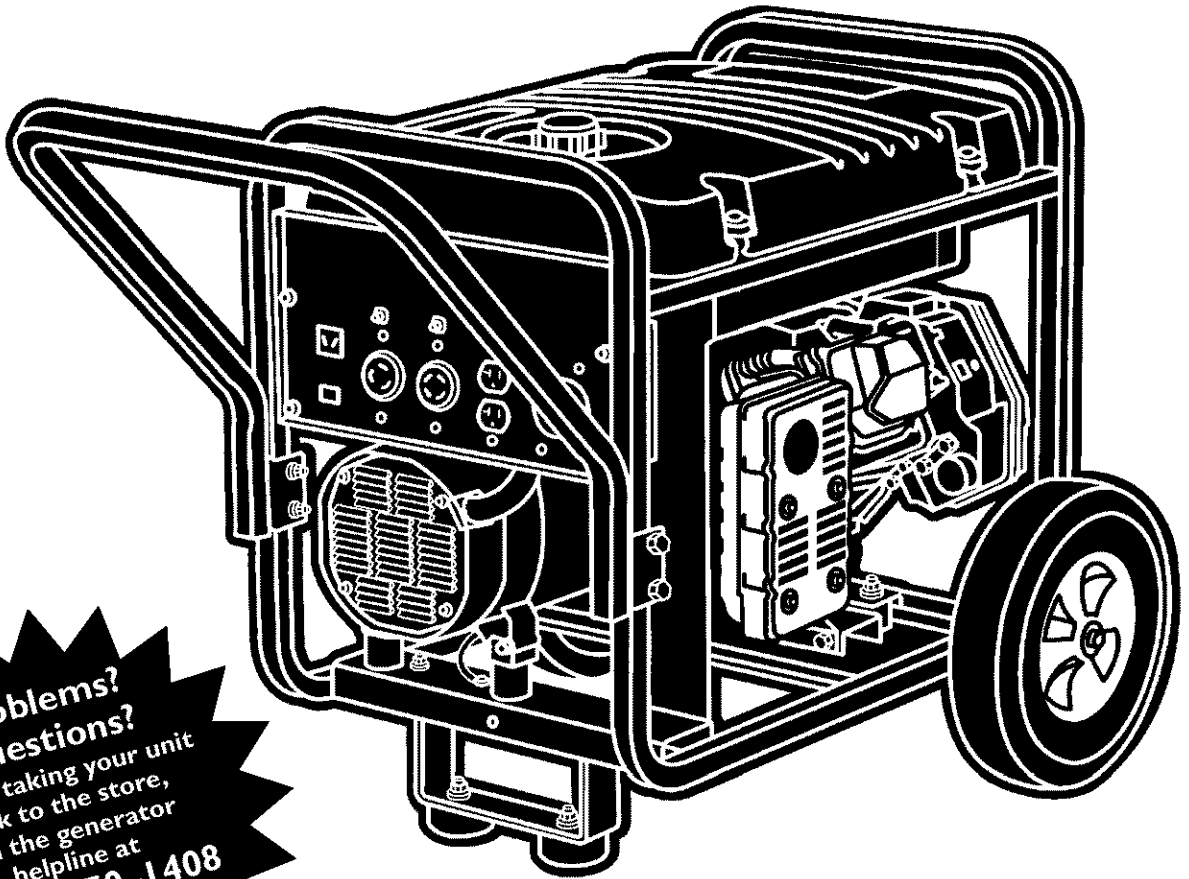

**Problems?
Questions?**

Before taking your unit
back to the store,
call the generator
helpline at

**1-800-270-1408
M-F 8-5 CT**

Model No. 1315-0 (7,500 Watt AC Generator) Manual No. B4369 Revision 3 (9/19/2000)

Visit our Generac website: www.generac-portables.com



This is the safety alert symbol. It is used to alert you to potential personal injury hazards. Obey all safety messages that follow this symbol to avoid possible injury or death.

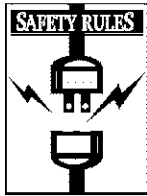

EQUIPMENT DESCRIPTION

This generator is an engine-driven, revolving field, alternating current (AC) generator. It was designed to supply electrical power for operating compatible electrical lighting, appliances, tools and motor loads. This manual contains information for a generator that operates 120 and/or 240 Volt, single phase, 60 Hz devices that require up to 7,500 watts (7.5 kW) of power that draw up to 62.5 Amps at 120 Volts or 31.2 Amps at 240 Volts.

CAUTION! Do Not exceed the generator's wattage/ampere capacity. Add up the rated watts of all devices you are connecting to generator receptacles at one time. This total should not be greater than 7,500 watts. See "Don't Overload The Generator" on page 12.

The 7,500EXL generator has the following features:

- 120/240 Volt, 30 Amp locking receptacle, a 120 Volt, 30 Amp locking receptacle, a 120 Volt, 20 Amp receptacle, and a 120/240 Volt, 50 Amp receptacle.
- Low Oil Shutdown: Automatically shuts down the engine if oil drops below safe operating pressure.
- Seven gallon overhead fuel tank with fuel gauge.
- The generator's revolving field is driven at about 3600 rpm by a Generac Power Systems 15 HP electric start engine.

DANGER! Do Not tamper with engine governed speed. High operating speeds are dangerous and increase risk of personal injury or damage to equipment. The generator supplies correct rated frequency and voltage only when running at proper governed speed. Incorrect frequency and/or voltage can damage some connected electrical loads. Operating at excessively low speeds imposes a heavy load. When adequate engine power is not available, engine life may be shortened.

SAFETY RULES

This generator set was designed and manufactured for specific applications. **Do Not** attempt to modify the unit or use it for any application it was not designed for. If you have any questions about your generator's application, ask your dealer/distributor or consult the factory.

The manufacturer could not possibly anticipate every circumstance that might involve a hazard. For that reason warnings in the manual and warnings on tags or decals affixed to the unit are not all-inclusive. If you intend to handle, operate or service the unit by a procedure or method not specifically recommended by the manufacturer, first make sure that such a procedure or method will not render this equipment unsafe or pose a threat to you and others.

Read this manual carefully and become familiar with your generator set. Know its applications, its limitations and any hazards involved.



WARNING:



The engine exhaust from this product contains chemicals known to the State of California to cause cancer, birth defects, or other reproductive harm.



DANGER! You must isolate the generator from the electric utility by opening the electrical system's main circuit breaker or main switch if this unit is used for backup power. **Failure to isolate the generator from the power utility may result in injury or death to electric utility workers and damage to the generator** due to a backfeed of electrical energy. Whenever unit is providing backup power, the electric utility must be notified.



DANGER! Generator exhaust gases contain **DEADLY** carbon monoxide gas. **Carbon monoxide, if breathed in sufficient concentrations, can cause unconsciousness or death.** Operate this equipment outdoors where adequate ventilation is available.

The Emission Control System for this generator is warranted for standards set by the Environmental Protection Agency. For warranty information refer to the engine owner's manual.

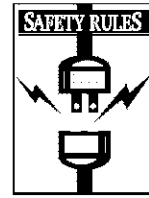

- The generator produces a very powerful voltage that can cause serious injury or death by electrocution. **Never** touch bare wires or receptacles. **Never** permit a child or any unqualified person to operate the generator.
- **Never** handle any kind of electrical cord or device while standing in water, while barefoot or while hands or feet are wet. Death or serious injury from electrocution may result.
- Use a ground fault circuit interrupter (GFCI) in any damp or highly conductive area (such as metal decking or steel work).
- **Never** use worn, bare, frayed or otherwise damaged electrical cords with the generator. Death, serious injury and property damage from electrical shock may result.
- **Gasoline is highly FLAMMABLE and its vapors are EXPLOSIVE. Never allow smoking, open flames, sparks or heat in the vicinity while handling gasoline.** Avoid spilling gasoline on a hot engine. Comply with all laws regulating storage and handling of gasoline.
- **Do Not** overfill the fuel tank. Always allow room for fuel expansion. **If tank is overfilled, fuel can overflow onto a hot engine and cause a FIRE or an EXPLOSION.**
- **Never** store a generator with fuel in the tank where gasoline vapors might reach an open flame, spark or pilot light (as on a furnace, water heater, clothes dryer). **FIRE** or an **EXPLOSION** may result.
- The unit requires an adequate flow of cooling air for its continued proper operation. **Never** operate the unit inside any room or enclosure where the free flow of cooling air into and out of the unit might be obstructed. Allow at least 2 feet of clearance on all sides of generator, even while operating unit outdoors, or you could damage the unit. See “Cold Weather Operation” on page 10.
- **Never** start or stop the unit with electrical loads connected to receptacles with the connected devices turned ON. Start the engine and let it stabilize before connecting any electrical loads. Disconnect all electrical loads before shutting down the generator.
- **Do Not** insert any object through cooling slots of the engine. You could damage the unit or injure yourself.

- **Never operate the generator:** in rain; in any enclosed compartment; when connected electrical devices overheat; if electrical output is lost; if engine or generator sparks; if flame or smoke is observed while unit is running; if unit vibrates excessively.

GROUNDING THE GENERATOR

The National Electric Code requires the frame and external electrically conductive parts of the generator be properly connected to approved earth ground. Local electrical codes may also require proper grounding of the unit. For this purpose, a ground lug (Figure 1) is provided on the cradle.

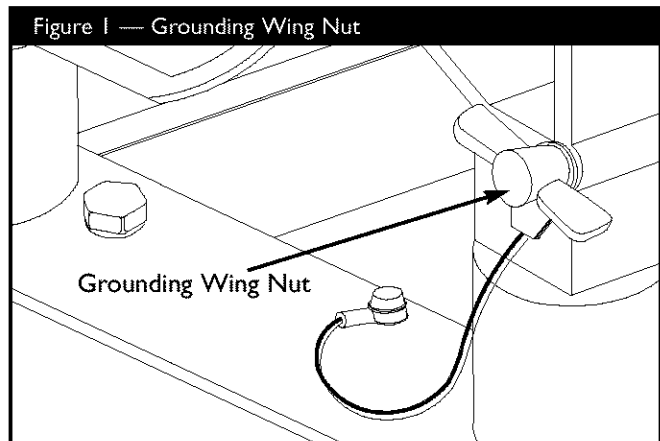

Generally, connecting a No. 12 AWG (American Wire Gauge) stranded copper wire to the ground lug screw and to an earth-driven copper or brass grounding rod (electrode) provides adequate protection against electrical shock. However, local codes may vary widely. Consult with a local electrician for grounding requirements in your area. Be sure to keep the ground wire attached while you connect the electrode.

Properly grounding the generator helps prevent electrical shock if ground fault conditions exists in the generator or in connected electrical devices. Proper grounding also helps dissipate static electricity, which often builds up in ungrounded devices.

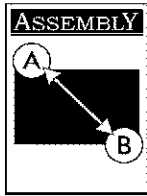

INSTALL WHEEL KIT AND BATTERY TRAY

To install these items, you need the following tools:

- Socket wrench with 1/2" or 13mm socket.
- Box or open end 3/8" wrench.

Install Wheel Kit

- Place the generator on a hard flat surface (Figure 2).
- Place temporary blocks beneath the cradle.
- Slide the axle through the holes in the brackets provided on the generator cradle and then add one spacer on each protruding end of the axle.

- Slide a wheel on each end of the axle and secure with washer and retaining pin. If wheel does not spin freely, omit one or both washers.

NOTE: Make sure the air inflation valve faces outward on each wheel.

- Attach the vibration mounts to the support leg with capscrews, washers, and lock nuts.
- Attach the support leg with two capscrews and two lock nuts to the cradle. Remove the temporary blocks.
- Attach the handle with four capscrews and four lock nuts on the control panel end of the unit.

Figure 2 — Assemble Wheel Kit

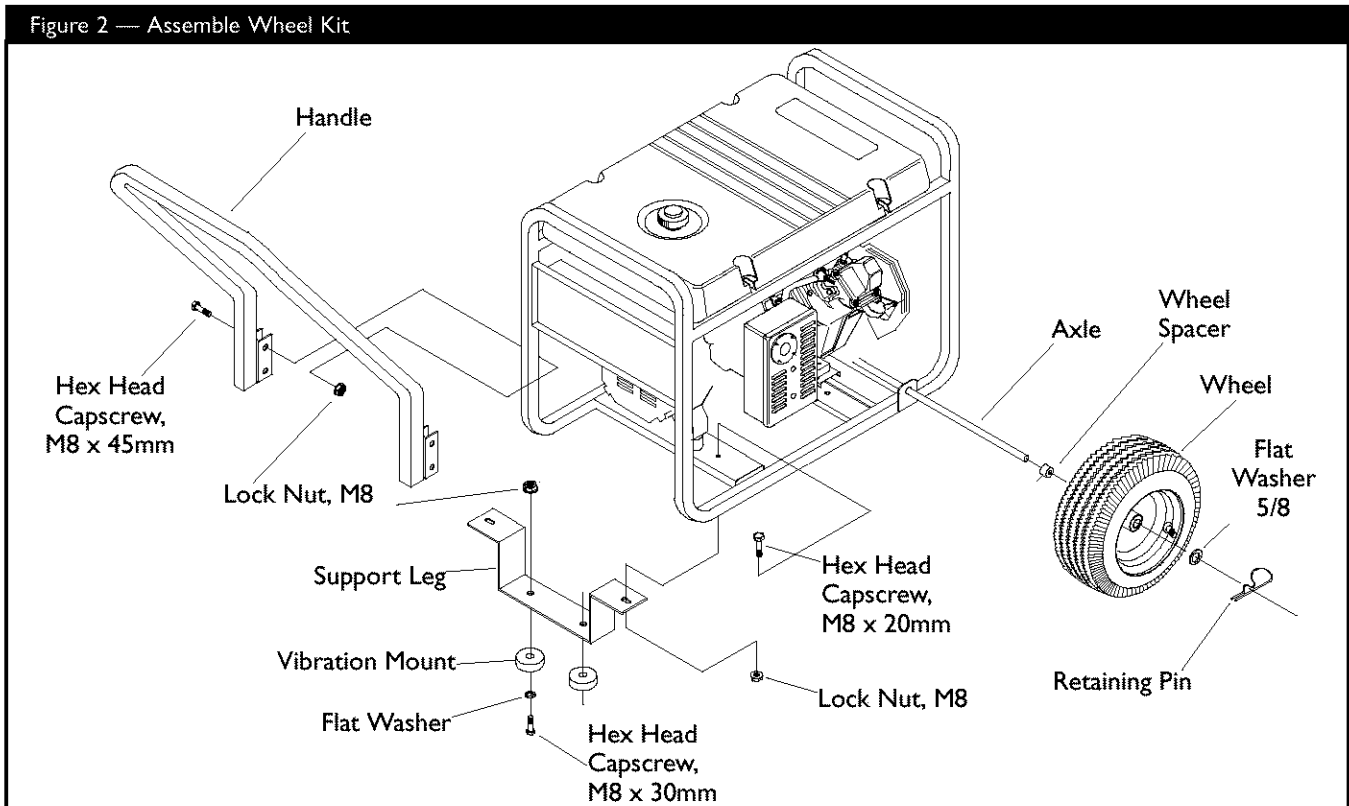

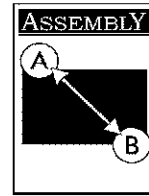

Installing Tray and Battery

To obtain electric start, you must purchase and install a 12 Volt DC battery (Series UI-109). The battery should be serviced as necessary and fully charged prior to installation. Install the battery as follows:

- Find the battery tray and fasteners shipped loose in the carton. You should have one battery hold down bracket, a black battery cable, a red battery cable, two 7" J bolts, two lock washers, two flat washers and two hex nuts.
- Remove the four battery tray screws from cradle.
- Position the battery tray and install with screws removed above (Figure 3).

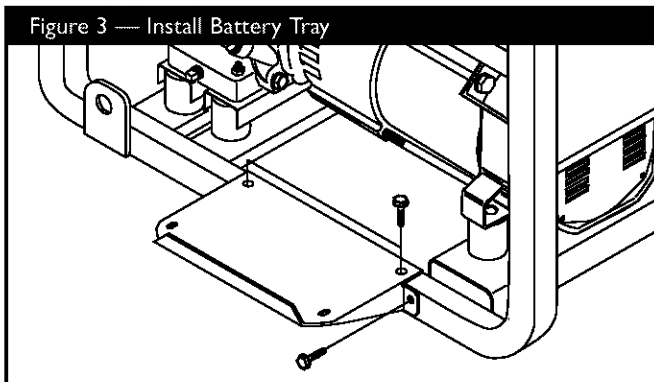

- Set battery onto tray.
- Retain battery to tray with hold down bracket, two J bolts, two lock washers, two flat washers and two hex nuts (Figure 4). Tighten with 3/8" wrench.

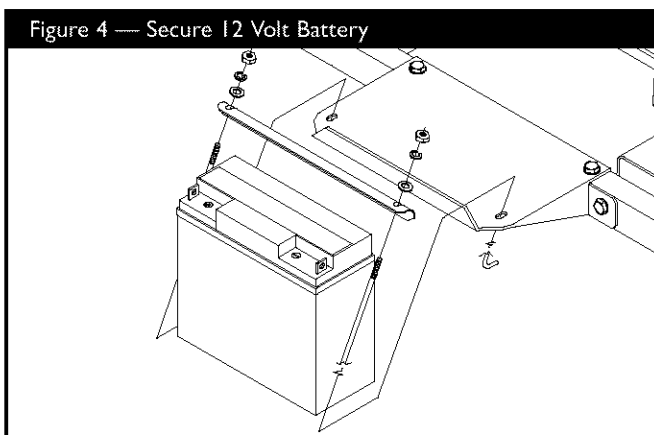

- Connect one end of the **red battery cable** to the outboard terminal of the engine start switch.
- Connect other end of the **red battery cable** from the engine start switch to **positive (+)** terminal on the battery (Figure 5).

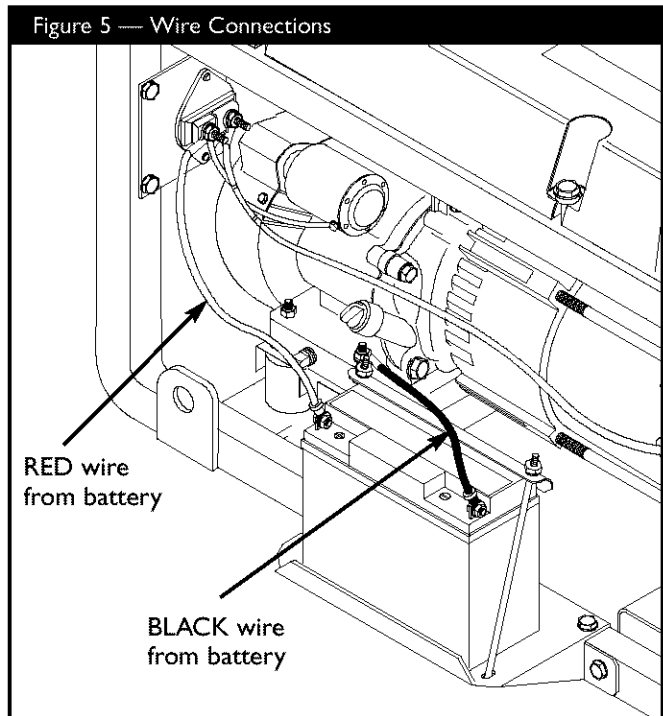

- Connect the **black battery cable** to the **negative (-)** terminal on the battery (Figure 5).
- Connect the other end of the black cable to the engine, **not the frame** (Figure 5).

CAUTION! Be sure the black cable is connected to the engine and not the frame. Failure to connect cable to the engine block will result in damage to the wiring which is not covered under warranty.

- Double check all connections to ensure they are in the correct locations and secure.



KNOW YOUR GENERATOR

Read this owner's manual and safety rules before operating your generator.

Compare the illustrations with your generator, to familiarize yourself with the locations of various controls and adjustments. Save this manual for future reference.

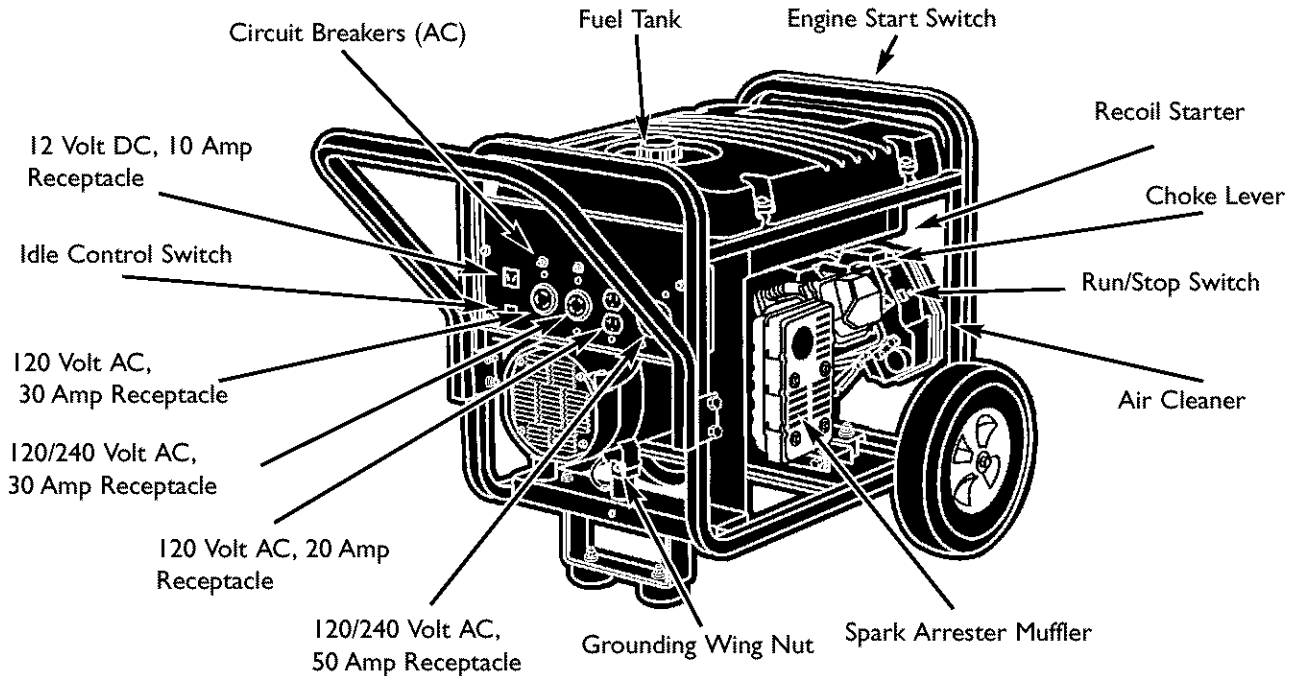

12 Volt DC, 10 Amp Receptacle — Recharge a discharged 12 Volt automotive type battery through this receptacle.

120/240 Volt AC, 50 Amp Receptacle — May be used to supply electrical power for the operation of 120/240 Volt AC, 50 Amp, single phase, 60 Hz electrical loads.

120/240 Volt AC, 30 Amp Locking Receptacle — May be used to supply electrical power for the operation of 120 and/or 240 Volt AC, 30 Amp, single phase, 60 Hz, AC electrical lighting, appliance, tool and motor loads.

120 Volt AC, 20 Amp Receptacle — May be used to supply electrical power for the operation of 120 Volt AC, 20 Amp, single phase, 60 Hz electrical lighting, appliance, tool and motor loads.

120 Volt AC, 30 Amp Locking Receptacle — May be used to supply electrical power for the operation of 120 Volt AC, 30 Amp, single phase, 60 Hz electrical lighting, appliance, tool and motor loads.

Air Cleaner — Uses a dry type filter element and foam pre-cleaner to limit the amount of dirt and dust sucked into the engine.

Choke Lever — Used when starting a cold engine.

Circuit Breakers (AC) — Each receptacle is provided with a circuit breaker to protect the generator against electrical overload. Breakers are "push to reset" type.

Engine Start Switch - Pressed to start the engine.

Fuel Tank — Capacity of seven (7) U.S. gallons.

Grounding Wing Nut — Used for proper grounding of unit.

Idle Control Switch — With this switch set to ON, printed circuit board in control panel automatically reduces engine speed when no load is connected and increases engine to proper speed when load is applied. However, be sure switch is OFF when starting engine.

Recoil Starter — Used as backup method of starting engine.

Run/Stop Switch — Set this switch to "RUN" before using recoil starter. Set switch to "STOP" to switch OFF engine.

Spark Arrester Muffler — Exhaust muffler lowers engine noise and is equipped with a spark arrester screen.

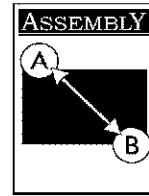

BEFORE STARTING THE ENGINE

Add Oil



WARNING! Any attempt to crank or start the engine before it has been properly filled with the recommended oil may result in an engine failure.

To fill your engine with oil:

- Place generator on a level surface.
- Clean area around oil fill and remove oil fill cap.
- Select the oil's viscosity grade and fill engine with oil following the instructions given in the engine owner's manual. **Do Not overfill!**
- Install oil fill cap.

NOTE: The generator's revolving field rides on a pre-lubricated and sealed ball bearing that requires no additional lubrication for the life of the bearing.

Add Gasoline



DANGER! Explosion Hazard! **Never** fill fuel tank indoors. **Never** fill fuel tank when engine is running or hot. **Do Not** light a cigarette or smoke when filling the fuel tank.



WARNING! Do Not overfill the fuel tank. Always allow room for fuel expansion.

- Use regular **UNLEADED** gasoline with the Generator engine. **Do Not** use premium gasoline. **Do Not** mix oil with gasoline.
- Clean area around fuel fill cap, remove cap.
- Add unleaded regular gasoline, slowly to fuel tank. Be careful not to overfill. Allow about 1/2" of tank space for fuel expansion (Figure 6).

Figure 6 — Fuel Expansion Space

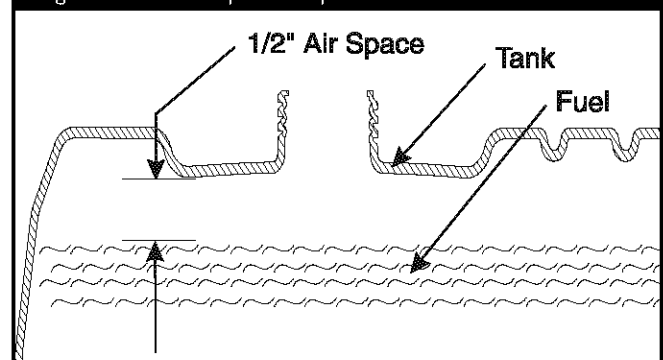

- Install fuel cap and wipe up any spilled gasoline.

IMPORTANT: It is important to prevent gum deposits from forming in essential fuel system parts such as the carburetor, fuel filter, fuel hose or tank during storage. Also, experience indicates that alcohol-blended fuels (called gasohol, ethanol or methanol) can attract moisture, which leads to separation and formation of acids during storage. Acidic gas can damage the fuel system of an engine while in storage.

To avoid engine problems, the fuel system should be emptied before storage of 30 days or longer. See "Storage" on page 13. **Never** use engine or carburetor cleaner products in the fuel tank or permanent damage may occur.



OPERATING THE GENERATOR

CAUTION! Never start or stop the engine with electrical loads connected to the unit and with the connected devices turned ON.

Starting the Engine

Disconnect all electrical loads from the generator. Use the following start instruction steps by numerical order:

1. Make sure the Idle Control switch is in “Off” position.
2. Turn the fuel valve to the “On” position (Figure 7).

Figure 7 — Fuel Valve Operation

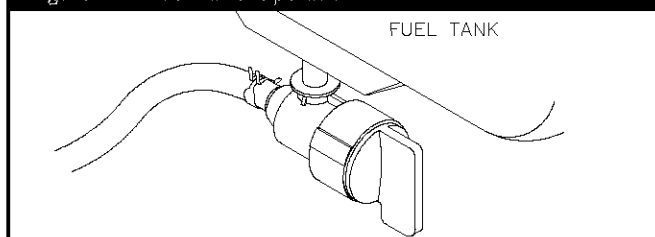

3. Set the Run/Stop switch to “Run” position (Figure 8).

Figure 8 — Run/Stop Switch

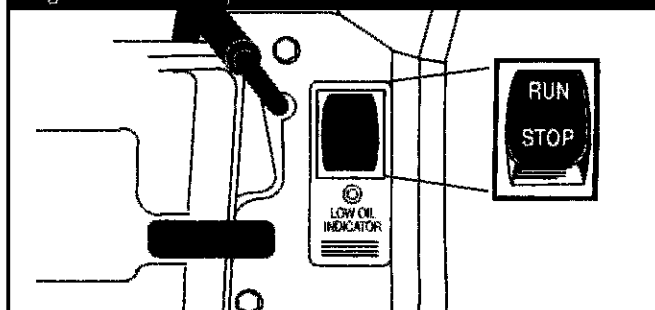

4. Place the choke lever in the “Full” choke position (Figure 9).

Figure 9 — Choke Lever

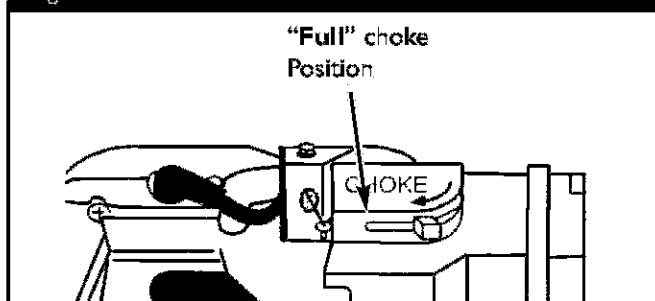

- 5A. For electric starting, press start switch on generator cradle until engine starts. To prolong the life of the starter components, press the starter button for no more than 15 seconds, then pause for 30 seconds.
- 5B. For manual starting, grasp the recoil handle and pull slowly until slight resistance is felt. Then pull rapidly one time only to start engine.
 - If engine starts, proceed to step 7.
 - If engine fails to start, proceed to step 6.
6. Move the choke lever to “Half” choke position, and pull recoil handle twice.
 - If engine fails to start, repeat steps 4 thru 6.
7. Move choke lever to “Run” position. If engine falters, move choke lever to “Half” choke position until the engine runs smoothly, and then to “Run” position.

NOTE: If engine still fails to start after 3 pulls, check for proper oil level in crankcase. This unit is equipped with a Low Oil Shutdown System. See engine manual.

Connecting Electrical Loads

- Let engine stabilize and warm up for a few minutes after starting.
- Plug in and turn on the desired 120 and/or 240 Volt AC, single phase, 60 Hertz electrical loads.
- **Do Not** connect 240 Volt loads to 120 Volt receptacles.
- **Do Not** connect 3-phase loads to the generator.
- **Do Not** connect 50-Hz loads to the generator.
- **DO NOT OVERLOAD THE GENERATOR.** Add up the rated watts (or amps) of all loads to be connected at one time. This total should not be greater than the rated wattage/ampere capacity of the generator. See “Don’t Overload the Generator” on page 11.

Stopping the Engine

- Unplug all electrical loads from generator panel receptacles. **Never** start or stop engine with electrical devices plugged in and turned on.
- Put the Idle Control switch in the “Off” position.
- Let engine run at no-load for 30 seconds to stabilize the internal temperatures of engine and generator.
- Move Run/Stop switch to “Stop”.
- Close the fuel shut-off valve.



Operating Automatic Idle Control

This control is designed to greatly improve fuel economy. **When this switch is turned "ON"**, the engine will only run at its normal high governed engine speed when an electrical load is connected. When the electrical load is removed, the engine will run at a reduced speed. **With the switch "Off"**, the engine will run constantly at high engine speed. **Always have the switch "Off" when starting and stopping the engine.**

Battery Safety

! DANGER! Storage batteries give off explosive hydrogen gas while recharging. An explosive mixture will remain around the battery for a long time after it has been charged. The slightest spark can ignite the hydrogen and cause an explosion. Such an explosion can shatter the battery and cause blindness or other serious injury.

! DANGER! Do Not permit smoking, open flame, sparks or any other source of heat around a battery. Wear protective goggles, rubber apron and rubber gloves when working around a battery. Battery electrolyte fluid is an extremely caustic sulfuric acid solution that can cause severe burns. If spill occurs, flush area with clear water immediately.

Charging a Battery

Your generator has the capability of recharging a discharged 12 Volt automotive or utility style storage battery. **Do Not** use the generator to charge any 6 Volt batteries. **Do Not** use the generator to crank an engine having a discharged battery.

To recharge 12 Volt batteries, proceed as follows:

- Check fluid level in all battery cells. If necessary, add **ONLY** distilled water to each cell. **Do Not** use tap water.
- If the battery is equipped with vent caps, make sure they are installed and are tight.
- If necessary, clean battery terminals.
- Connect battery charge cable connector plug to panel receptacle identified by the words "12-VOLTS D.C."
- Connect battery charge cable clamp with red handle to the **positive (+)** battery terminal (Figure 10).

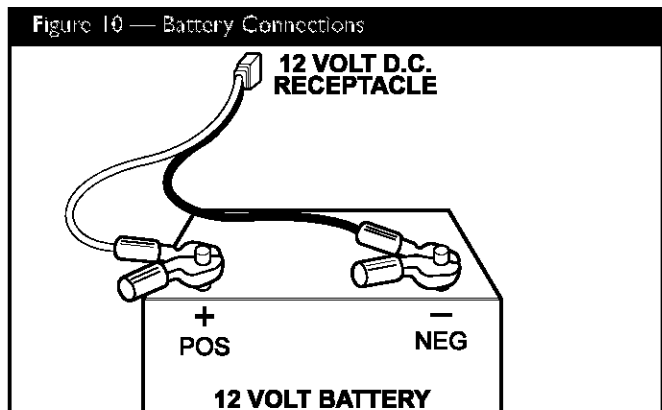

- Connect battery charge cable clamp with **black** handle to the **negative (-)** battery terminal (Figure 10).
- Start engine. Let the engine run while battery recharges.
- When battery has charged, shut down engine.

NOTE: Use an automotive hydrometer to test battery state of charge and condition. Follow the hydrometer manufacturer's instructions carefully. Generally, a battery is considered to be at 100% state of charge when specific gravity of its fluid (as measured by hydrometer) is 1.260 or higher.



COLD WEATHER OPERATION

Under certain weather conditions (temperatures below 40°F [4°C] and a high dew point), your Generac generator may experience icing of the carburetor and/or the crankcase breather system.

In an emergency, use the original shipping box as a temporary shelter:

- Cut off all flaps.
- Cut out one of the long sides of the box to expose exhaust side of unit. Ensure a minimum of two feet clearance between open side of box and nearest object.
- Cut appropriate slots to access receptacles and clear handles.
- Start unit, then place box over it.

IMPORTANT: Remove shelter when temperature is above 40°F [4°C].

For a more permanent shelter, build a structure that will enclose three sides and the top of the generator:

- Make sure entire muffler-side of generator is exposed. Note that your generator may appear different from that shown in Figure 11.

Figure 11 — Temporary Cold Weather Shelter

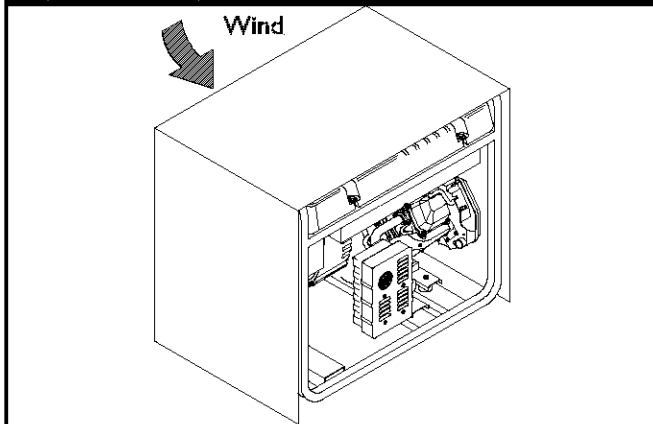

- Ensure a minimum of two feet clearance between open side of box and nearest object.
- Face exposed end away from wind and elements.
- Enclosure should hold enough heat created by the generator to prevent problems.



CAUTION! Never run unit indoors. Do Not enclose generator any more than shown. Remove shelter when temperatures are above 40°F [4°C].

RECEPTACLES

This generator is equipped with the following receptacles:

120 Volt AC, 20 Amp Receptacle

This outlet is protected against overload by a 20 Amp push-to-reset circuit breaker (Figure 12).

Figure 12 — 120 Volt AC, 20 Amp Receptacle

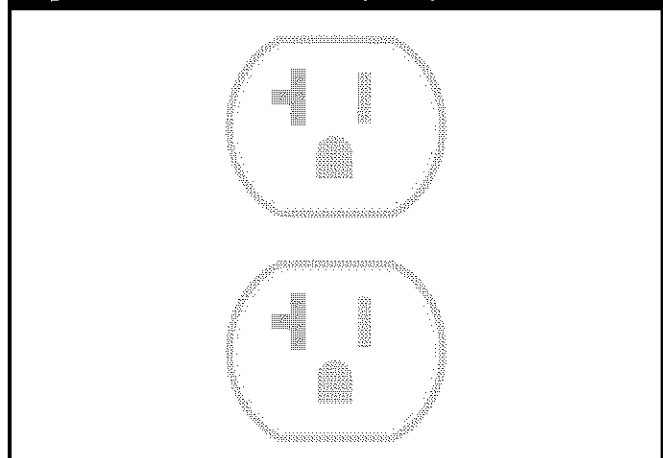

Use each socket to operate 120 Volt AC, single phase, 60 Hz electrical loads requiring up to 2,400 watts (2.4 kW) at 20 Amps. Use cord sets that are rated for 125 Volt loads at 20 Amps (or greater).

120 Volt AC, 30 Amp Locking Receptacle

Use a NEMA L5-30 plug with this receptacle. Connect a 3-wire cord set rated for 125 Volts AC at 30 Amps to the plug (Figure 13).



Figure 13 — 120 Volt AC, 30 Amp Locking Receptacle

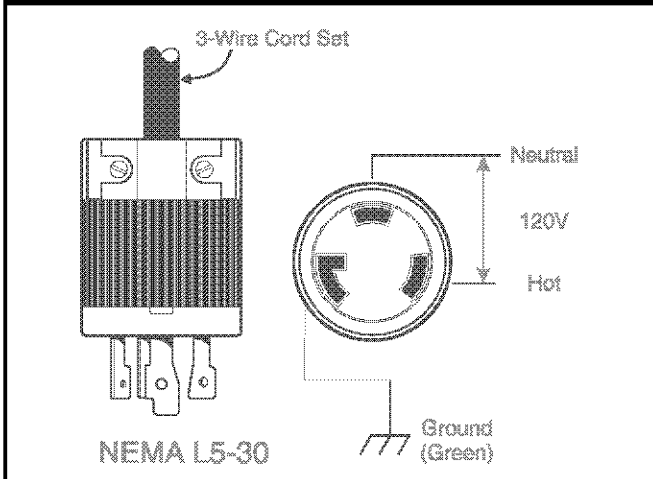

Use this receptacle to operate 120 Volt AC, 60 Hz, single phase loads requiring up to 3,600 watts (3.6 kW) of power at 30 Amps. The outlet is protected by a 30 Amp push-to-reset circuit breaker.

120/240 Volt AC, 30 Amp Locking Receptacle

Use a NEMA L14-30 plug with this receptacle. Connect a 4-wire cord set rated for 250 Volt AC loads at 30 Amps (or greater). You can use the same 4-wire cord if you plan to run a 120 Volt load (Figure 14).

Figure 14 — 120/240 Volt AC, 30 Amp Locking Receptacle

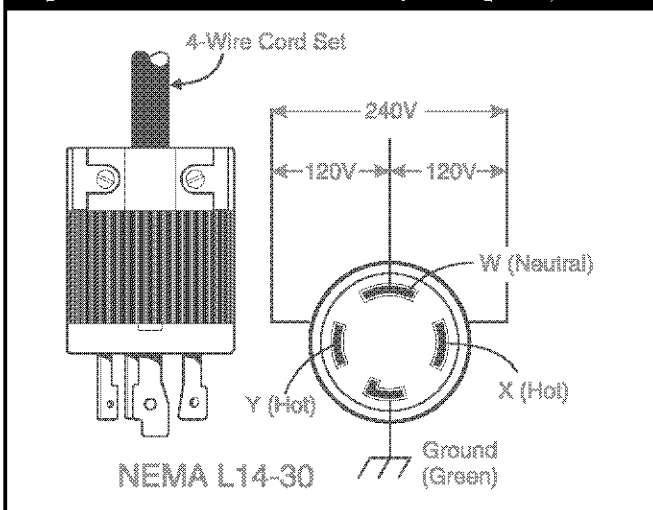

This receptacle powers 120 Volt AC, single phase, 60 Hz loads requiring up to 3,600 watts of power (3.6 kW). Or it will operate 240 Volt AC, single phase, 60Hz loads up to 7,200 watts (7.2 kW). This outlet is protected by a 30 Amp push-to-reset circuit breaker.

120/240 Volt AC, 50 Amp Receptacle

Use a NEMA 14-50 plug with this receptacle. Connect a 4-wire cord set rated for 240 Volt AC loads at 50 Amps to the plug (Figure 15).

Figure 15 — 120/240 Volt AC, 50 Amp Receptacle

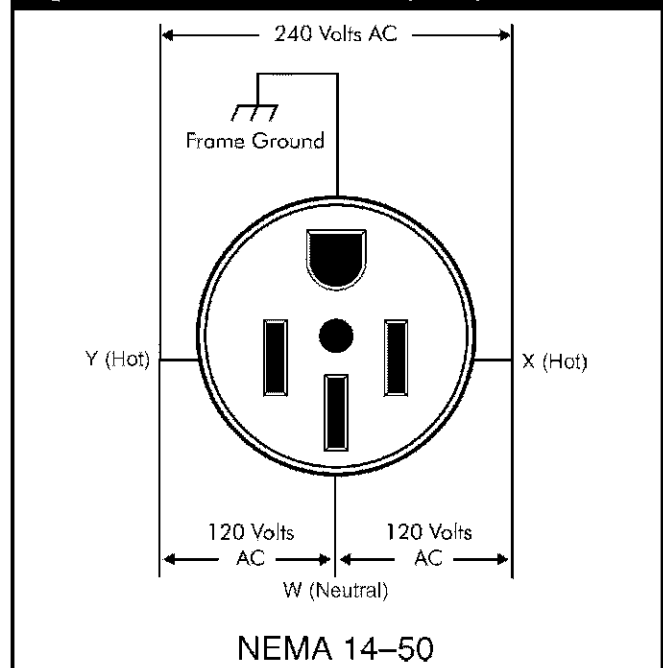

Use this receptacle to operate 240 Volt AC, 60 Hz, single phase loads requiring up to 7,500 watts (7.5 kW) of power.

CAUTION! Although this outlet states it has a 240 Volt 50 Amp rating (up to 12,500 watts), the generator is only rated for 7,500 watts. Powering loads that exceed the wattage / amperage capacity of the generator can damage it or cause serious injuries.



DON'T OVERLOAD THE GENERATOR

Overloading a generator in excess of its rated wattage capacity can result in damage to the generator and/or connected electrical devices. Observe the following, to prevent overloading the unit:

- Add up the total wattage of all electrical devices to be connected at one time. This total should NOT be greater than the generator's wattage capacity.
- The rated wattage of lights can be taken from light bulbs. The rated wattage of tools, appliances and motors can usually be found on a data plate or decal affixed to the device.
- If the appliance, tool or motor does not give wattage, multiply 120 Volts times ampere rating to determine watts (volts x amps = watts).
- Some electric motors, such as induction types, require about three times more watts of power for starting than for running. This surge of power lasts for only a few seconds when starting such motors. Be sure you allow for this high starting wattage when selecting electrical devices to connect to your generator. First figure the watts needed to start the largest motor. Add to that figure the running watts of all other connected loads.
- Items in the wattage reference guide (Figure 16) are provided to help you to determine how many items the generator can operate at one time.

Figure 16 — Wattage Reference Guide

Recreational/Home Uses		Professional/Contractor Uses	
Tool/Appliance.....	Watts	Tool/Appliance.....	Watts
AM/FM clock radio.....	50	*1/3 hp airless sprayer.....	600
Light bulb.....	100	3/8" hammer drill.....	600
Fan.....	200	Variable speed Sawzall®.....	960
20" color TV.....	400	½" power drill.....	1000
*Deep freezer.....	500	Quartz-halogen work light.....	1000
Personal computer and 15" monitor.....	800	Belt sander.....	1200
*1/3 hp furnace fan blower.....	800	7 ¼" circular saw.....	1500
Microwave oven.....	800	7 ¼" worm drive saw.....	1600
*18 cu ft refrigerator.....	800	*1 ½ hp air compressor.....	1800
Sump pump.....	1000	*10" power miter saw.....	1800
Electric skillet.....	1250	6" bench grinder.....	1800
*½ hp water well pump.....	1400	*6" table planer.....	1800
*12,000 Btu window air conditioner.....	1400	*10" table/radial arm saw.....	2000
Space heater.....	1800	Wire feed welder.....	2400
Electric water heater.....	4000		

* allow 3 times listed watts for starting this device

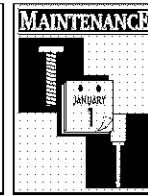
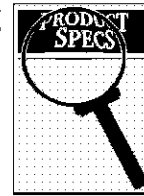

SPECIFICATIONS

Maximum Surge Watts	9,375 watts
Continuous Wattage Capacity	7,500 watts
Power Factor	1.0
Rated Maximum Continuous Load Current	
At 120 Volts	62.5 Amps
At 240 Volts	31.2 Amps
Phase	1-phase
Rated Frequency	60 Hertz
Fuel Tank Capacity	7 U.S. gallons

GENERAL MAINTENANCE RECOMMENDATIONS

The owner/operator is responsible for making sure that all periodic maintenance tasks are completed on a timely basis; that all discrepancies are corrected; and that the unit is kept clean and properly stored. **Never operate a damaged or defective generator.**

Engine Maintenance

See engine owner's manual for instructions.

Generator Maintenance

Generator maintenance consists of keeping the unit clean and dry. Operate and store the unit in a clean dry environment where it will not be exposed to excessive dust, dirt, moisture or any corrosive vapors. Cooling air slots in the generator must not become clogged with snow, leaves or any other foreign material.

NOTE: Do Not use a garden hose to clean generator. Water can enter engine fuel system and cause problems. In addition, if water enters generator through cooling air slots, some of the water will be retained in voids and cracks of the rotor and stator winding insulation. Water and dirt buildup on the generator internal windings will eventually decrease the insulation resistance of these windings.

To Clean the Generator

- Use a damp cloth to wipe exterior surfaces clean.
- Soft, bristle brush may be used to loosen caked on dirt or oil.
- A vacuum cleaner may be used to pick up loose dirt and debris.
- Low pressure air (not to exceed 25 psi) may be used to blow away dirt. Inspect cooling air slots and opening on generator. These openings must be kept clean and unobstructed.

STORAGE

The generator should be started at least once every seven days and allowed to run at least 30 minutes. If this cannot be done and you must store the unit for more than 30 days, use the following guidelines to prepare it for storage.

Generator Storage

- Clean the generator as outlined in "To Clean the Generator."
- Check that cooling air slots and openings on generator are open and unobstructed.
- Disconnect negative battery cable from battery. Protect battery from freezing temperatures.



DANGER! Storage covers can be flammable. **Do Not** place a storage cover over a hot generator. Let the unit cool for a sufficient time before placing a cover on the unit.

Engine Storage

See engine owner's manual for instructions.

Other Storage Tips

- **Do Not** store gasoline from one season to another.
- Replace your gasoline can if it starts to rust. Rust and/or dirt in a gasoline can cause problems if you use contaminated fuel.
- Store unit in a clean and dry area.

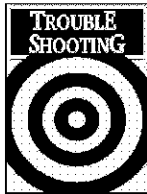

TROUBLESHOOTING

Problem	Cause	Solution
Engine is running, but no AC output is available.	<ol style="list-style-type: none"> 1. Circuit breaker is open. 2. Poor connection or defective cord set. 3. Connected device is bad. 4. Fault in generator. 	<ol style="list-style-type: none"> 1. Reset circuit breaker. 2. Check and repair. 3. Connect another device that is in good condition. 4. Contact Generac service facility.
Engine runs good but bogs down when loads are connected.	<ol style="list-style-type: none"> 1. Short circuit in a connected load. 2. Generator is overloaded. 3. Engine speed is too slow. 4. Shorted generator circuit. 	<ol style="list-style-type: none"> 1. Disconnect shorted electrical load. 2. See "Don't Overload the Generator" on page 12. 3. Contact Generac service facility. 4. Contact Generac service facility.
Engine will not start; or starts and runs rough.	<ol style="list-style-type: none"> 1. Run/Stop switch set to "Stop". 2. Dirty air cleaner. 3. Out of gasoline. 4. Stale gasoline. 5. Spark plug wire not connected to spark plug. 6. Bad spark plug. 7. Water in gasoline. 8. Overchoking. 9. Low oil level. 10. Excessively rich fuel mixture. 11. Intake valve stuck open or closed. 12. Engine has lost compression. 13. Battery is dead. 	<ol style="list-style-type: none"> 1. Set switch to "Run". 2. Clean or replace air cleaner. 3. Fill fuel tank. 4. Drain gas tank and fill with fresh fuel. 5. Connect wire to spark plug. 6. Replace spark plug. 7. Drain gas tank; fill with fresh fuel. 8. Put choke lever to "no choke" position. 9. Fill crankcase to proper level. 10. Contact Generac service facility. 11. Contact Generac service facility. 12. Contact Generac service facility. 13. Recharge or replace battery.
Engine shuts down during operation.	<ol style="list-style-type: none"> 1. Out of gasoline. 2. Low oil level. 3. Fault in engine. 	<ol style="list-style-type: none"> 1. Fill fuel tank. 2. Fill crankcase to proper level. 3. Contact Generac service facility.
Engine lacks power.	<ol style="list-style-type: none"> 1. Load is too high. 2. Dirty air filter. 3. Engine needs to be serviced. 	<ol style="list-style-type: none"> 1. See "Don't Overload the Generator" on page 12. 2. Replace air filter. 3. Contact Generac service facility.
Engine "hunts" or falters.	<ol style="list-style-type: none"> 1. Choke is opened too soon. 2. Carburetor is running too rich or too lean. 	<ol style="list-style-type: none"> 1. Move choke to halfway position till engine runs smoothly. 2. Contact Generac service facility.

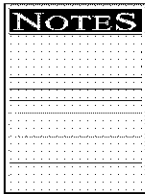

NOTES

Lined area for taking notes, consisting of multiple horizontal lines.

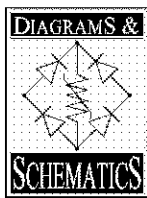

ELECTRICAL SCHEMATIC

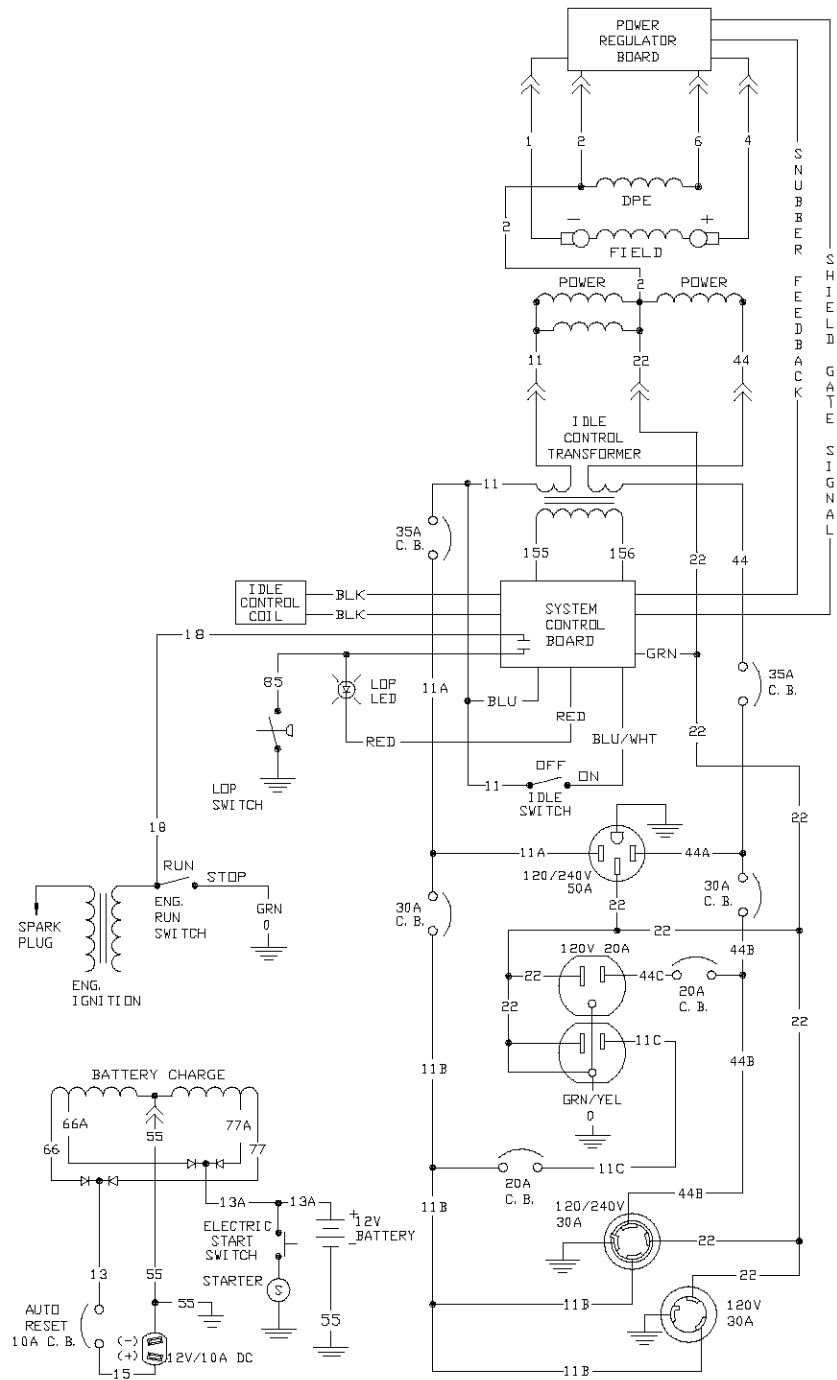

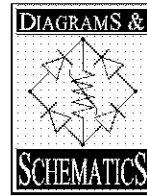

WIRING DIAGRAM

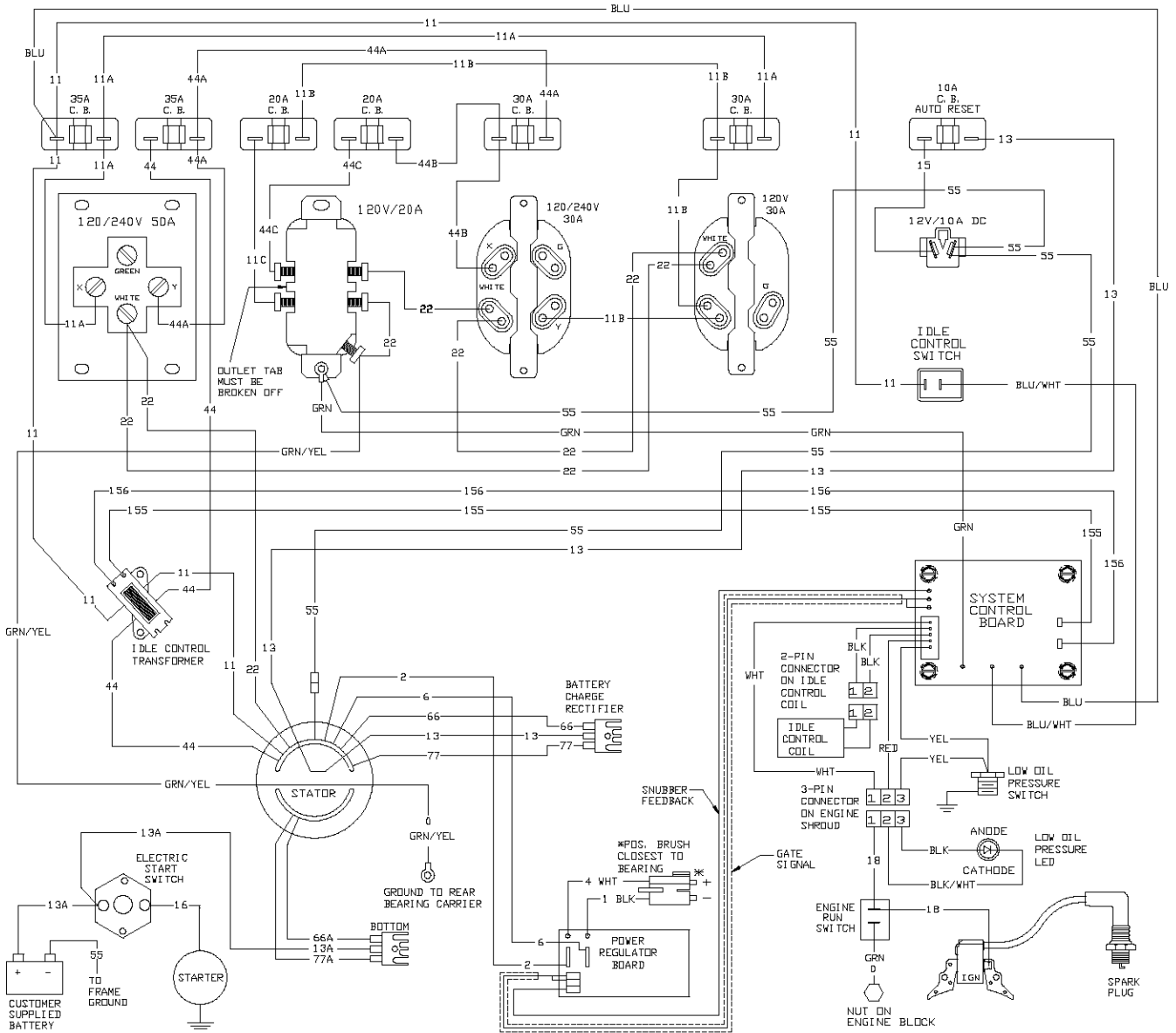

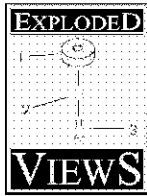

EXPLODED VIEW - MAIN UNIT

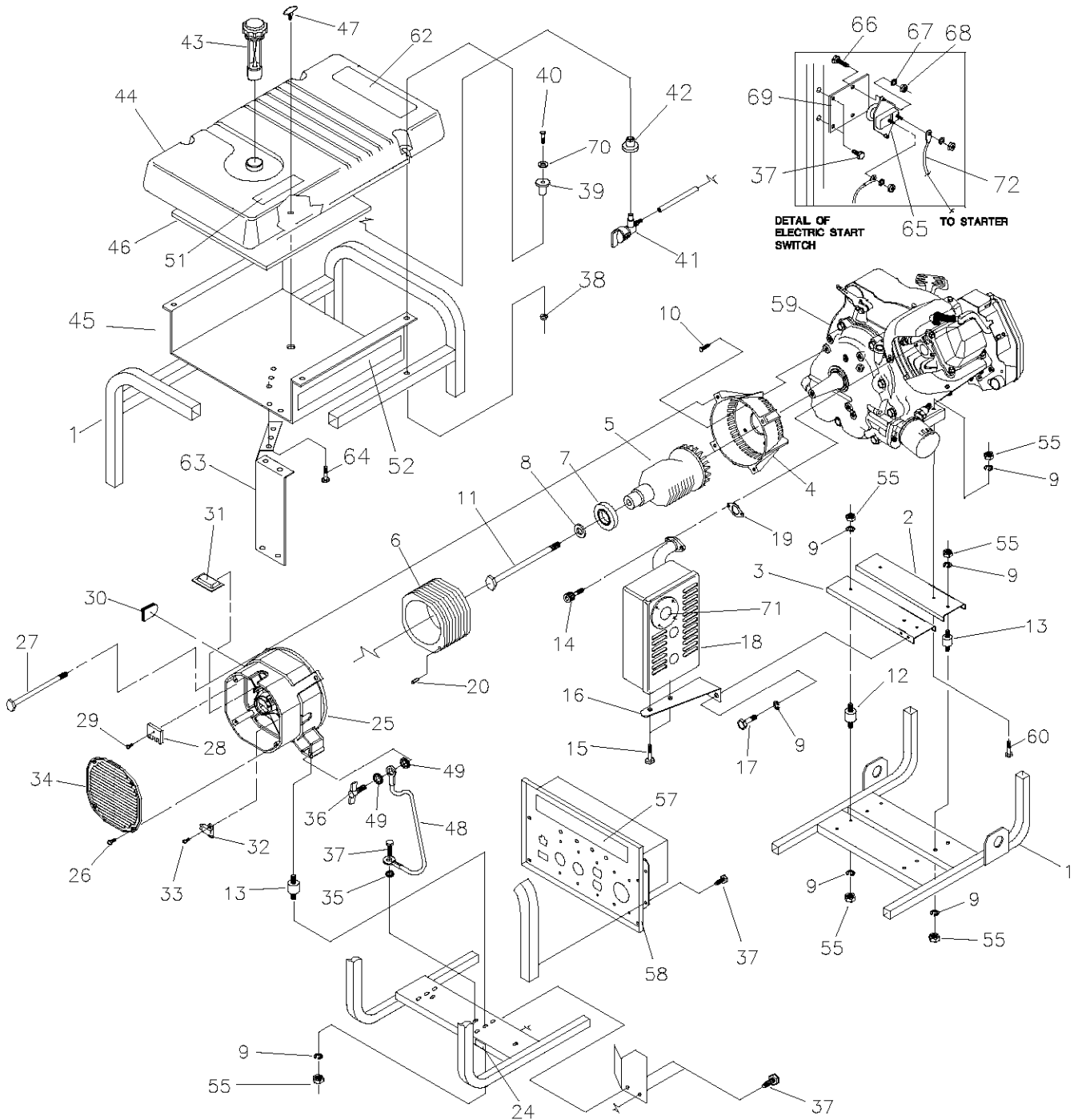

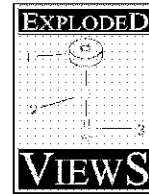

PARTS LIST – MAIN UNIT

Item	Part #	Qty	Description	Item	Part #	Qty	Description
1	G92432	1	CRADLE	47	85000	1	CLIP, Insulation
2	G92531	1	SUPPORT, Engine	48	14353621	1	WIRE, Ground
3	G92731	1	SUPPORT, Engine & Muffler	49	26850	2	LW, EXT, Shakeproof M6
4	92247	1	HOUSING, Engine Adapter	51	92982	1	DECAL, Danger
5	B1342G	1	ASSEMBLY, Rotor	52	B4367	2	DECAL, Heat Shield
6	B1897G	1	ASSEMBLY, Stator	55	25244	12	NUT, 5/16-18 Hex
7	65791	1	BEARING	57	B4368	1	DECAL, Control Panel
8	67451	1	WASHER, Special Flat - M8	58	B4366A	1	ASSEMBLY, Control Box
9	22129	12	WASHER, Lock - M8	59	NSP	1	ENGINE
10	86307	4	HHMS, 5/16-24 x 3/4 SEMS	60	22531	2	HHCS, 5/16-18 x 1-3/4"
11	47481	1	HHCS, 5/16-24 x 10.625	62	93826	1	DECAL, Start Instructions
12	92609	2	MOUNT, Vibration	63	B96068	1	SHIELD, Heat
13	82857	4	MOUNT, Vibration	64	56893	5	CRIMPTITE, 10-24 x 1/2
14	40976	2	SCREW, M8 - 1.25 x 20	65	77282	1	SWITCH, Starter
15	66476	2	CAPSCREW, M6 - 1.0 x 12mm	66	22287	2	SCREW, 1/4 - 20 x 3/4
16	92532	1	BRACKET, Muffler	67	22097	2	LOCKWASHER, M6
17	22142	2	SCREW, 5/16 - 18 x 3/4	68	22127	2	NUT, 1/4 - 20 Hex
18	A7433	1	MUFFLER	69	78289	1	BRACKET, Starter Switch
19	90239	1	GASKET, Muffler	70	22473	4	WASHER, M6 Flat
20	81917	1	PIN, Roll 4mm x 10	71	83083	1	SCREEN, Spark Arrester
24	B4986	1	DECAL, Ground	72	96113	1	ASSY., Wire Starter
25	66825C	1	CARRIER, Rear Bearing				
26	74908	4	TAPTITE, M5-0.8 x 10	Items Not Illustrated			
27	66449L	4	BOLT, Stator M6-1 x 165mm	65787	1	Battery Charge Cable	
28	65795	2	RECTIFIER, Battery Charge	B4369	1	Generator Owner's Manual	
29	66849C	1	TAPTITE, M5-0.8 x 30	A8927	1	Engine Owner's Manual	
30	67022	1	GROMMET, Rubber	BB3061	2	Oil, 28 oz.	
31	84132	1	ASSEMBLY, Power Regulator	96113	1	Wire, Assembly Starter	
32	66386	1	ASSEMBLY, Brush Holder	22129	2	Lockwasher M8	
33	66849	2	TAPTITE, M5-0.8 x 16	22145	2	Flatwasher M8	
34	B4871	1	COVER, Bearing Carrier	45771	2	Hex Nut M8-1.25	
35	22769	1	WASHER, Shakeproof Int. #10	96925	1	Battery Tiedown	
36	86494	1	SCREW, M6-1.0 x 16 Wing	96924	2	J-Bolt M8-1.25	
37	86292	9	HHCS, - #10 Self Driller	96923	1	Battery Tray	
38	77395	4	NUT, Flange Lock - M6	15453621	1	Battery Cable Positive	
39	83465	4	GROMMET, Tank	15553621	1	Battery Cable Negative	
40	57058	4	HHMS, M6-1.0 x 55	37806	1	120 Volt 30 Amp Locking Plug	
41	80270	1	VALVE, Tank	43438	1	120/240 Volt 30 Amp Locking Plug	
42	78299	1	BUSHING, Plastic Tank				
43	B4363	1	CAP, with Gauge, Fuel	Optional Accessories Not Included			
44	B1695	1	TANK, Fuel 7 Gal.	84883		Cord Wrap	
45	B92039	1	SHIELD, Heat	43630		120/240 Volt 50 Amp Plug	
46	92665	1	INSULATION, #2-1/4" Thick				

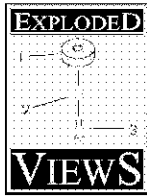

EXPLODED VIEW AND PARTS LIST – WHEEL KIT

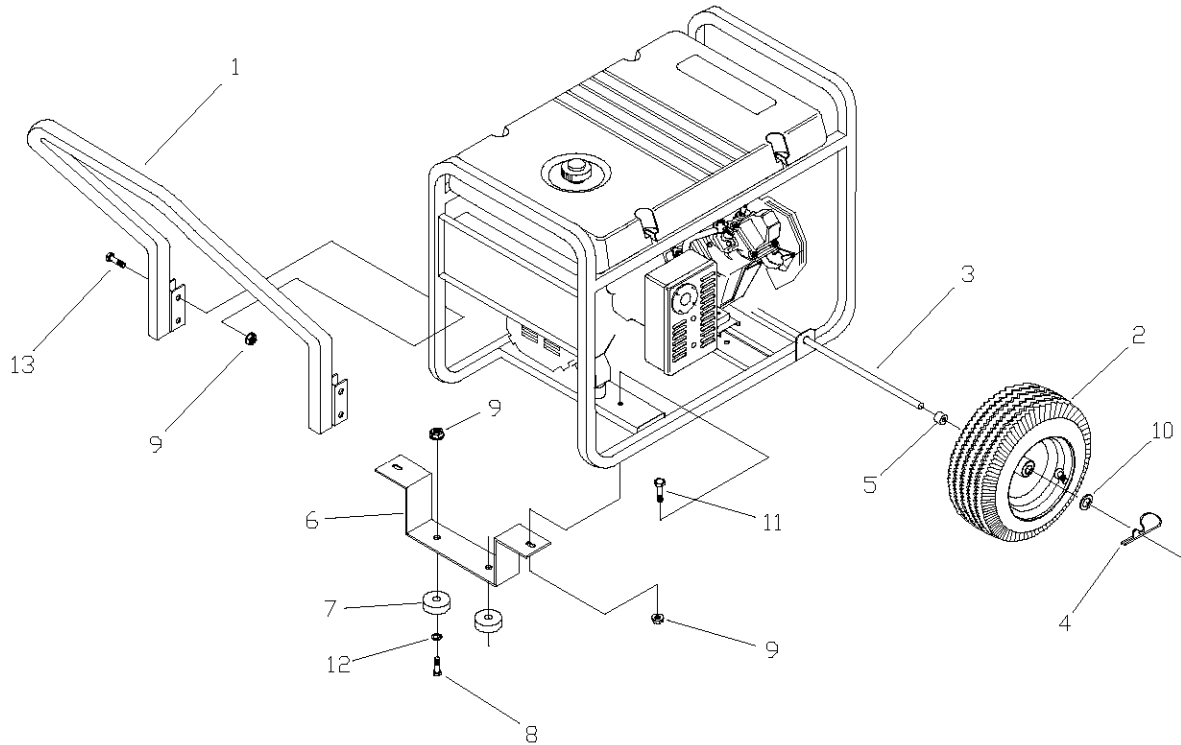

Item	Part #	Qty	Description
1	B93393A	1	HANDLE
2	89742	2	WHEEL
3	93693A	1	AXLE
4	87005	2	PIN, Retaining
5	B89635	2	SPACER, Wheel
6	B93696	1	LEG, Support
7	27007	2	MOUNT, Vibration
8	42909	2	CAPSCREW, Hex Hd. M8 - 1.25 x 30
9	52858	8	NUT, Lock M8
10	22247	2	WASHER, Wheel
11	39253	2	CAPSCREW, Hex Hd. - M8 - 1.25 x 20
12	22145	2	WASHER, Vibration Mtg.
13	39287	4	HHCS, M8 - 1.25 x 45 GR 10.9

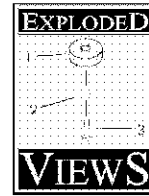

EXPLODED VIEW AND PARTS LIST – CONTROL PANEL

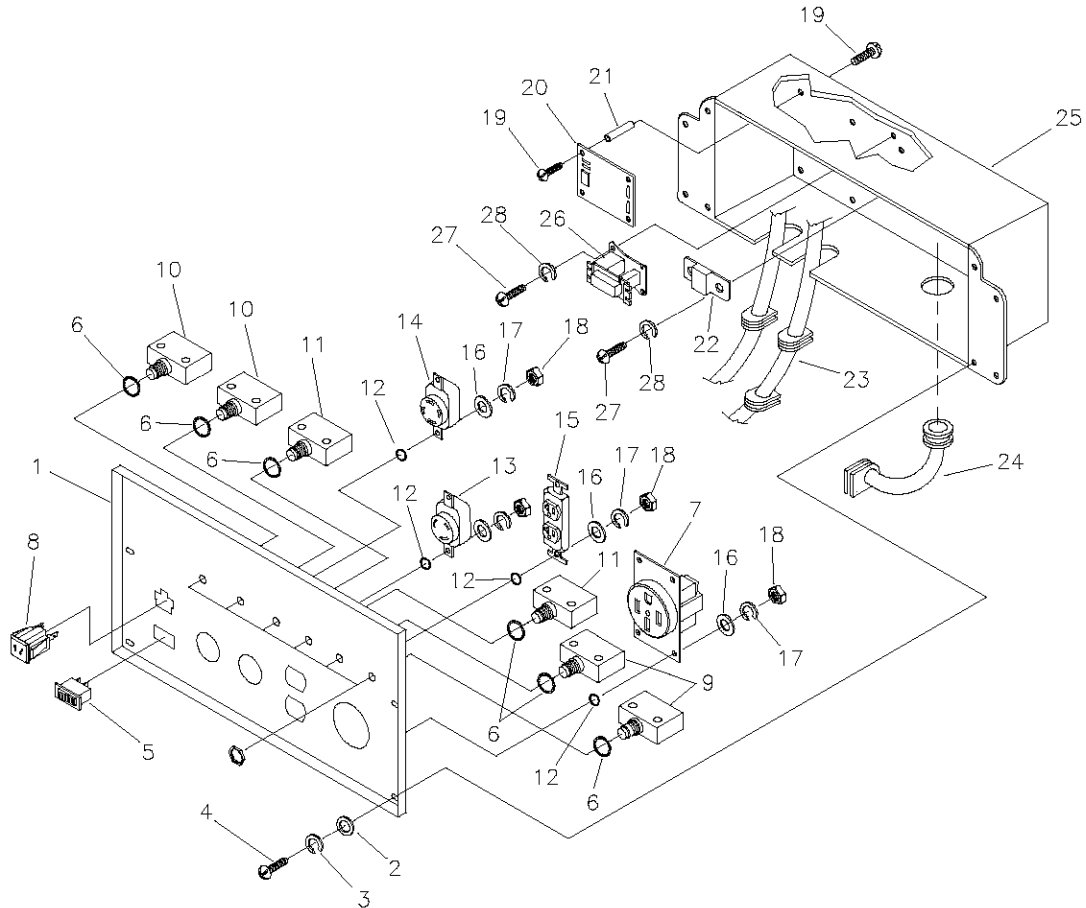

Item	Part #	Qty.	Description	Item	Part #	Qty.	Description
1	BB4461	1	PANEL, Control	15	68759	1	OUTLET, 20A, 120V
2	23897	4	WASHER, #10 M5 Flat	16	43180	10	WASHER, M4 Flat
3	49226	4	WASHER, M5 Lock	17	22264	10	WASHER, #8 M4 Lock
4	91526	4	SCREW, M5-0.8 x 12 mm	18	51715	10	NUT, M4 - 0.7 Hex
5	82538	1	SWITCH, Idle Control	19	64526	8	SCREW, #6-32 x 3/8"
6	82881	6	WASHER, 7/16" Int. Lock	20	83970	1	BOARD, System Control
7	B4262	1	OUTLET, 50A, 240V	21	64525	4	3/4" Hex Standoff
8	90418	1	OUTLET, 10A, 12VDC	22	87962	1	CIRCUIT BREAKER, 10A (automatic), 12V
9	75207N	2	CIRCUIT BREAKER, 35 AMP	23	84335	1	ASSEMBLY, Wire Harness
10	75207A	2	CIRCUIT BREAKER, 30 AMP	24	84134	1	GROMMET, Rubber Connector
11	75207	2	CIRCUIT BREAKER, 20 AMP	25	B92069	1	BOX, Control Panel
12	23365	10	WASHER, #8 Shakeproof	26	84028	1	TRANSFORMER, Idle Control
13	68868	1	OUTLET, 30A, 120V Locking	27	43181	4	SCREW, M3 - 0.5 x 10 mm
14	43437	1	OUTLET, 30A, 120V/240V Locking	28	43182	4	WASHER, M3 Lock

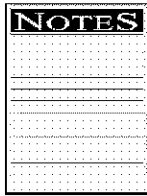

NOTES

LIMITED WARRANTY

FOR "GN" ENGINE DRIVEN PORTABLE GENERATORS

GENERAC PORTABLE PRODUCTS (hereafter referred to as the COMPANY) warrants to the original purchaser that the alternator and control panel for its portable generator will be free from defects in materials or workmanship for the items and period set forth below from the date of original purchase. This warranty is not transferable and applies only to portable generators driven by a GN-Series engine.

	Consumer*	Commercial*
Alternator	2 years (2nd year parts only)	1 year
Engine	Warranted solely by the engine manufacturer	

With the exception of European Community Countries, all units bound for export shall be warranted for One (1) Year in Consumer applications, and 90 days in Commercial applications as defined below.

***NOTE:** For the purpose of this warranty, "consumer use" means personal residential household use by original purchaser. This warranty does not apply to units used for Prime Power in place of utility. "Commercial Use" means all other uses, including rental, construction, commercial and income producing purposes. Once a generator has experienced commercial use, it shall thereafter be considered a commercial use generator for the purposes of this warranty.

During said warranty period, the COMPANY will, at its option, repair or replace any part which, upon examination by the COMPANY, is found to be defective under normal use and service**. Starting batteries are not warranted by the COMPANY. All transportation costs under warranty, including return to the factory if necessary, are to be borne by the purchaser and prepaid by the purchaser. This warranty does not cover normal maintenance and service and does not apply to a generator set, alternator, or parts which have been subjected to improper or unauthorized installation or alteration, misuse, negligence, accident, overloading, overspeeding, improper maintenance, repair or storage so as, in the COMPANY's judgement, to adversely affect its performance and reliability.

****NORMAL WEAR:** As with all mechanical devices, the generator need periodic parts service and replacement to perform well. This warranty will not cover repair when normal use has exhausted the life of a part or generator.

THERE IS NO OTHER EXPRESS WARRANTY. THE COMPANY HEREBY DISCLAIMS ANY AND ALL IMPLIED WARRANTIES, INCLUDING BUT NOT LIMITED TO THOSE OF MERCHANTABILITY AND FITNESS FOR A PARTICULAR PURPOSE TO THE EXTENT PERMITTED BY LAW. THE DURATION OF ANY IMPLIED WARRANTIES WHICH CANNOT BE DISCLAIMED IS LIMITED TO THE TIME PERIOD AS SPECIFIED IN THE EXPRESS WARRANTY. LIABILITY FOR CONSEQUENTIAL, INCIDENTAL OR SPECIAL DAMAGES UNDER ANY AND ALL WARRANTIES IS EXCLUDED. THE COMPANY ALSO DISCLAIMS ANY RESPONSIBILITY FOR INCIDENTAL OR CONSEQUENTIAL DAMAGES, SUCH AS THE LOSS OF TIME OR THE USE OF THE POWER EQUIPMENT, OR ANY COMMERCIAL LOSS DUE TO THE FAILURE OF THE EQUIPMENT. ANY IMPLIED WARRANTIES ARE LIMITED TO THE DURATION OF THIS WRITTEN WARRANTY.

Some states do not allow limitations on how long an implied warranty lasts, or the exclusion or limitation of incidental or consequential damages, so the above limitations or exclusions may not apply to you. This warranty gives you specific legal rights and you may also have other rights, which vary from state to state.

For service, see your nearest COMPANY- authorized warranty service facility or call 1-877-544-0982. Warranty service can be performed only by a COMPANY- authorized service facility. This warranty will not apply to service at any other facility. At the time of requesting warranty service, evidence of original purchase date must be presented.

GENERAC PORTABLE PRODUCTS
Jefferson, Wisconsin 53549