

Operator's Manual

CRAFTSMAN®

1/2 in., 19.2 VOLT CORDLESS DRILL-DRIVER Variable Speed / Reversible

Model No.
315.114850

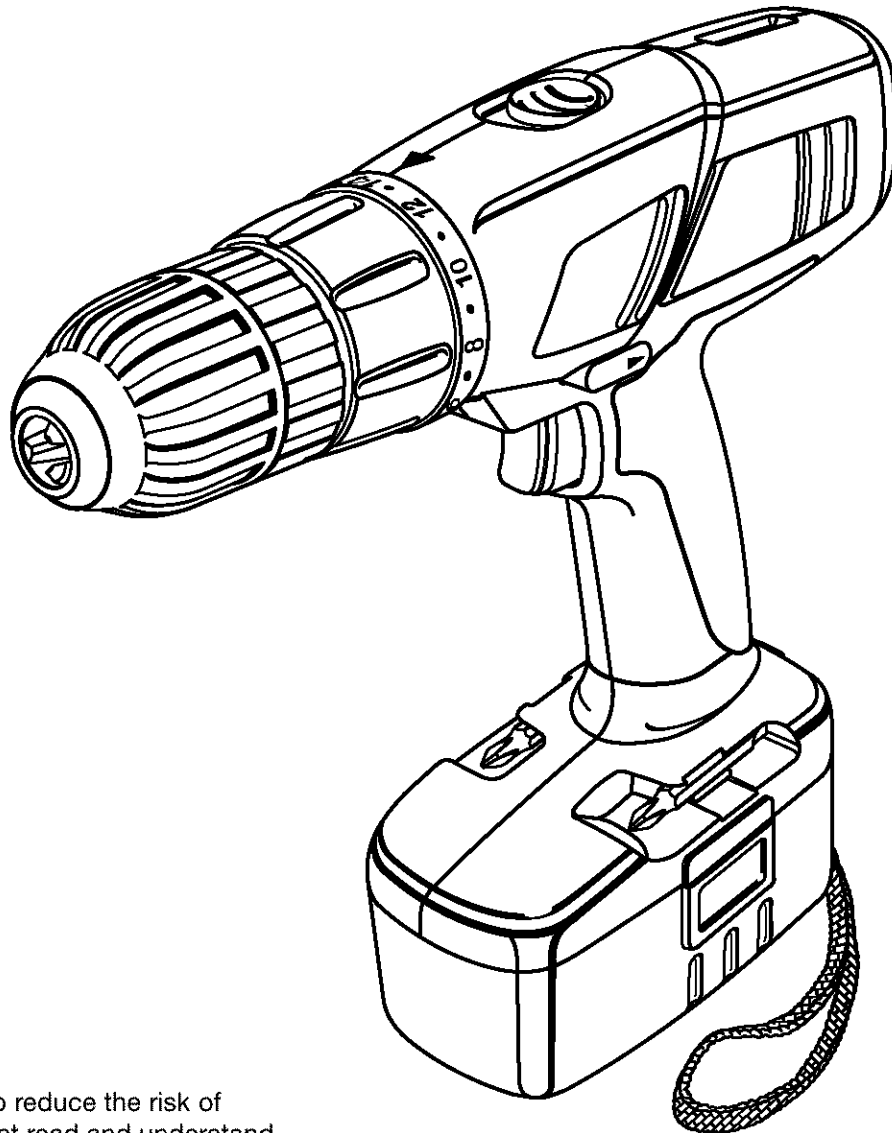

⚠ WARNING: To reduce the risk of injury, the user must read and understand the operator's manual before using this product.

Customer Help Line: 1-800-932-3188

Sears, Roebuck and Co., 3333 Beverly Rd., Hoffman Estates, IL 60179 USA
Visit the Craftsman web page: www.sears.com/craftsman

983000-464
2-04

Save this manual for future reference



TABLE OF CONTENTS

■ Warranty	2
■ Introduction	2
■ General Safety Rules	3-4
■ Specific Safety Rules	4
■ Safety Instructions for Charger	5
■ Symbols.....	6-7
■ Features	8-9
■ Unpacking	10
■ Operation.....	11-16
■ Maintenance.....	17
■ Exploded View And Repair Parts List.....	19
■ Parts Ordering / Service	20

WARRANTY

FULL ONE YEAR WARRANTY ON CRAFTSMAN 1/2 in. CORDLESS DRILL-DRIVER

If this **CRAFTSMAN** 1/2 in. Cordless Drill-Driver fails to give complete satisfaction within one year from the date of purchase, **RETURN IT TO THE NEAREST SEARS STORE OR SEARS SERVICE CENTER IN THE UNITED STATES**, and Sears will repair it, free of charge.

If this **CRAFTSMAN** 1/2 in. Cordless Drill-Driver is used for commercial or rental purposes, this warranty applies for only 90 days from the date of purchase.

This warranty gives you specific legal rights, and you may also have other rights which vary from state to state.

Sears, Roebuck and Co., Dept. 817WA, Hoffman Estates, IL 60179

INTRODUCTION

This tool has many features for making its use more pleasant and enjoyable. Safety, performance, and dependability have been given top priority in the design of this product making it easy to maintain and operate.

GENERAL SAFETY RULES

⚠ WARNING: READ AND UNDERSTAND ALL INSTRUCTIONS. Failure to follow all instructions listed below, may result in electric shock, fire and/or serious personal injury.

SAVE THESE INSTRUCTIONS

WORK AREA

- **Keep your work area clean and well lit.** Cluttered benches and dark areas invite accidents.
- **Do not operate power tools in explosive atmospheres, such as in the presence of flammable liquids, gases, or dust.** Power tools create sparks which may ignite the dust or fumes.
- **Keep bystanders, children, and visitors away while operating a power tool.** Distractions can cause you to lose control.

ELECTRICAL SAFETY

- **A battery operated tool with integral batteries or a separate battery pack must be recharged only with the specified charger for the battery.** A charger that may be suitable for one type of battery may create a risk of fire when used with another battery. Use battery only with charger listed.

MODEL	BATTERY PACK	CHARGER
315.114850	ITEM NO. 9 11375 (1323517 or 1323903)	ITEM NO. 9 11041 (1425301)

- **Use battery operated tool only with specifically designated battery pack.** Use of any other batteries may create a risk of fire. Use only with battery pack listed.
- **Do not abuse the cord. Never use the cord to carry the charger. Keep cord away from heat, oil, sharp edges, or moving parts. Replace damaged cords immediately.** Damaged cords may create a fire.

PERSONAL SAFETY

- **Stay alert, watch what you are doing and use common sense when operating a power tool. Do not use tool while tired or under the influence of drugs, alcohol, or medication.** A moment of inattention while operating power tools may result in serious personal injury.
- **Dress properly. Do not wear loose clothing or jewelry. Contain long hair. Keep your hair, clothing, and gloves away from moving parts.** Loose clothes, jewelry, or long hair can be caught in moving parts.
- **Avoid accidental starting. Be sure switch is in the locked or off position before inserting battery pack.** Carrying tools with your finger on the switch or inserting the battery pack into a tool with the switch on, invites accidents.

- **Remove adjusting keys or wrenches before turning the tool on.** A wrench or a key that is left attached to a rotating part of the tool may result in personal injury.
- **Do not overreach. Keep proper footing and balance at all times.** Proper footing and balance enables better control of the tool in unexpected situations. Do not use on a ladder or unstable support.
- **Use safety equipment. Always wear eye protection.** Dust mask, non-skid safety shoes, hard hat, or hearing protection must be used for appropriate conditions.
- **Do not wear loose clothing or jewelry. Contain long hair.** Loose clothes, jewelry, or long hair can be drawn into air vents.
- **Do not use on a ladder or unstable support.** Stable footing on a solid surface enables better control of the tool in unexpected situations.

TOOL USE AND CARE

- **Use clamps or other practical way to secure and support the workpiece to a stable platform.** Holding the work by hand or against your body is unstable and may lead to loss of control.
- **Do not force tool. Use the correct tool for your application.** The correct tool will do the job better and safer at the rate for which it is designed.
- **Do not use tool if switch does not turn it on or off.** A tool that cannot be controlled with the switch is dangerous and must be repaired.
- **Disconnect battery pack from tool or place the switch in the locked or off position before making any adjustments, changing accessories, or storing the tool.** Such preventive safety measures reduce risk of starting the tool accidentally.
- **Store idle tools out of reach of children and other untrained persons.** Tools are dangerous in the hands of untrained users.
- **When battery pack is not in use, keep it away from other metal objects like: paper clips, coins, keys, nails, screws, or other small metal objects that can make a connection from one terminal to another.** Shorting the battery terminals together may cause sparks, burns, or a fire.
- **Maintain tools with care. Keep cutting tools sharp and clean.** Properly maintained tools, with sharp cutting edges are less likely to bind and are easier to control.
- **Check for misalignment or binding of moving parts, breakage of parts, and any other condition that may affect the tool's operation. If damaged, have the tool serviced before using.** Many accidents are caused by poorly maintained tools.
- **Use only accessories that are recommended by the manufacturer for your model.** Accessories that may be suitable for one tool, may create a risk of injury when used on another tool.
- **Keep the tool and its handle dry, clean and free from oil and grease.** Always use a clean cloth when cleaning. Never use brake fluids, gasoline, petroleum-based products, or any strong solvents to clean your tool.

GENERAL SAFETY RULES

SERVICE

- Tool service must be performed only by qualified repair personnel. Service or maintenance performed by unqualified personnel may result in a risk of injury.
- When servicing a tool, **use only identical replacement parts**. Follow instructions in the Maintenance section of this manual. Use of unauthorized parts or failure to follow Maintenance Instructions may create a risk of shock or injury.

SPECIFIC SAFETY RULES

- **Hold tool by insulated gripping surfaces when performing an operation where the cutting tool may contact hidden wiring.** Contact with a “live” wire will also make exposed metal parts of the tool “live” and shock the operator.

ADDITIONAL RULES FOR SAFE OPERATION

- **Know your power tool. Read operator’s manual carefully. Learn its applications and limitations, as well as the specific potential hazards related to this tool.** Following this rule will reduce the risk of electric shock, fire, or serious injury.
- **Always wear safety glasses with side shields.** Everyday glasses have only impact resistant lenses. They are NOT safety glasses. Following this rule will reduce the risk of eye injury.

RULES FOR BATTERY TOOLS

- Battery tools do not have to be plugged into an electrical outlet; therefore, they are always in operating condition. Be aware of possible hazards when not using your battery tool or when changing accessories. Following this rule will reduce the risk of electric shock, fire, or serious personal injury.
- **Do not place battery tools or their batteries near fire or heat.** This will reduce the risk of explosion and possibly injury.
- Batteries vent hydrogen gas and can explode in the presence of a source of ignition, such as a pilot light. To reduce the risk of serious personal injury, never use any cordless product in the presence of open flame. An exploded battery can propel debris and chemicals. If exposed, flush with water immediately.
- **Do not charge battery tool in a damp or wet location.** Following this rule will reduce the risk of electric shock.
- **For best results, your battery tool should be charged in a location where the temperature is more than 50°F but less than 100°F. Do not store outside or in vehicles.**
- **Under extreme usage or temperature conditions, battery leakage may occur. If liquid comes in contact with your skin, wash immediately with soap and water, then neutralize with lemon juice or vinegar. If liquid gets into your eyes, flush them with clean water for at least 10 minutes, then seek immediate medical attention.** Following this rule will reduce the risk of serious personal injury.

SAFETY INSTRUCTIONS FOR CHARGER

⚠ WARNING! Read and understand all instructions. Failure to follow all instructions listed below, may result in electric shock, fire and/or serious personal injury.

- Before using battery charger, read all instructions and cautionary markings in this manual, on battery charger, battery, and product using battery to prevent misuse of the products and possible injury or damage.

CAUTION: To reduce the risk of electric shock or damage to the charger and battery, charge only nickel-cadmium rechargeable batteries as specifically designated on your charger. Other types of batteries may burst, causing personal injury or damage.

- Never use a battery that has been dropped or received a sharp blow. A damaged battery is subject to explosion. Properly dispose of a dropped or damaged battery immediately.
- **Do not expose charger to wet or damp conditions.** Water entering charger will increase the risk of electric shock.
- Do not use any attachment or accessory not recommended by the battery charger manufacturer. Attachments and accessories that may be suitable for one tool may become hazardous when used on another tool.
- **Do not abuse cord or charger. Never use the cord to carry the charger.** Do not pull the charger cord rather than the plug when disconnecting from receptacle. Damage to the cord or charger could occur and create an electric shock hazard. Replace damaged cords immediately.
- Make sure cord is located so that it will not be stepped on, tripped over, come in contact with sharp edges or moving parts or otherwise subjected to damage or stress. This will reduce the risk of accidental falls, which could cause injury, and damage to the cord, which could result in electric shock.
- Keep cord and charger from heat to prevent damage to housing or internal parts.

- Do not let gasoline, oils, petroleum-based products, etc. come in contact with plastic parts. They contain chemicals that can damage, weaken, or destroy plastic.
- **An extension cord should not be used unless absolutely necessary.** Use of improper extension cord could result in a risk of fire and electric shock. If extension cord must be used, make sure:

- a. That pins on plug of extension cord are the same number, size and shape as those of plug on charger.
- b. That extension cord is properly wired and in good electrical condition; and
- c. That wire size is large enough for AC ampere rating of charger as specified below:

Cord Length (Feet)	25'	50'	100'
Cord Size (AWG)	16	16	16

Note: AWG = American Wire Gage

- Do not operate charger with a damaged cord or plug, which could cause shorting and electric shock. If damaged, have the charger replaced by an authorized serviceman.
- **Do not operate charger if it has received a sharp blow, been dropped, or otherwise damaged in any way.** Take it to an authorized serviceman for electrical check to determine if the charger is in good working order.
- **Do not disassemble charger. Take it to an authorized serviceman when service or repair is required. Incorrect reassembly may result in a risk of electric shock or fire.**
- Unplug charger from outlet before attempting any maintenance or cleaning to reduce the risk of electric shock.
- **Disconnect charger from the power supply when not in use.** This will reduce the risk of electric shock or damage to the charger if metal items should fall into the opening. It also will help prevent damage to the charger during a power surge.
- **Save these instructions.** Refer to them frequently and use them to instruct others who may use this tool. If you loan someone this tool, loan them these instructions also to prevent misuse of the product and possible injury.









⚠ WARNING: Some dust created by power sanding, sawing, grinding, drilling, and other construction activities contains chemicals known to cause cancer, birth defects or other reproductive harm. Some examples of these chemicals are:

- lead from lead-based paints,
- crystalline silica from bricks and cement and other masonry products, and
- arsenic and chromium from chemically-treated lumber.

Your risk from these exposures varies, depending on how often you do this type of work. To reduce your exposure to these chemicals: work in a well ventilated area, and work with approved safety equipment, such as those dust masks that are specially designed to filter out microscopic particles.



SYMBOLS

Some of the following symbols may be used on this tool. Please study them and learn their meaning. Proper interpretation of these symbols will allow you to operate the tool better and safer.

SYMBOL	NAME	DESIGNATION/EXPLANATION
V	Volts	Voltage
A	Amperes	Current
Hz	Hertz	Frequency (cycles per second)
W	Watt	Power
min	Minutes	Time
~	Alternating Current	Type of current
==	Direct Current	Type or a characteristic of current
n_0	No Load Speed	Rotational speed, at no load
	Class II Construction	Double-insulated construction
.../min	Per Minute	Revolutions, strokes, surface speed, orbits etc., per minute
	Wet Conditions Alert	Do not expose to rain or use in damp locations.
	Read The Operator's Manual	To reduce the risk of injury, user must read and understand operator's manual before using this product.
	Eye Protection	Always wear safety goggles or safety glasses with side shields and a full face shield when operating this product.
	Safety Alert	Precautions that involve your safety.
	No Hands Symbol	Failure to keep your hands away from the blade will result in serious personal injury.
	No Hands Symbol	Failure to keep your hands away from the blade will result in serious personal injury.
	No Hands Symbol	Failure to keep your hands away from the blade will result in serious personal injury.
	No Hands Symbol	Failure to keep your hands away from the blade will result in serious personal injury.

SYMBOLS

The following signal words and meanings are intended to explain the levels of risk associated with this product.

SYMBOL	SIGNAL	MEANING
	DANGER:	Indicates an imminently hazardous situation, which, if not avoided, will result in death or serious injury.
	WARNING:	Indicates a potentially hazardous situation, which, if not avoided, could result in death or serious injury.
	CAUTION:	Indicates a potentially hazardous situation, which, if not avoided, may result in minor or moderate injury.
	CAUTION:	(Without Safety Alert Symbol) Indicates a situation that may result in property damage.

SERVICE

Servicing requires extreme care and knowledge and should be performed only by a qualified service technician. For service we suggest you return the product to your nearest **AUTHORIZED SERVICE CENTER** for repair. When servicing, use only identical replacement parts.

WARNING:

Observe all normal safety precautions related to avoiding electrical shock.

WARNING:

To avoid serious personal injury, do not attempt to use this product until you read thoroughly and understand completely the operator's manual. Save this operator's manual and review frequently for continuing safe operation and instructing others who may use this product.

WARNING:



The operation of any power tool can result in foreign objects being thrown into your eyes, which can result in severe eye damage. Before beginning power tool operation, always wear safety goggles or safety glasses with side shields and a full face shield when needed. We recommend Wide Vision Safety Mask for use over eyeglasses or standard safety glasses with side shields. Always use eye protection which is marked to comply with ANSI Z87.1.

SAVE THESE INSTRUCTIONS

FEATURES

SPECIFICATIONS

Chuck	1/2 in. Keyless
Motor	19.2 Volt DC
Switch	Variable Speed
Gear Train	2 Speed
No Load Speed	0-400/0-1400/min.
Clutch	24 Positions
Charger Input	120 V. 60 Hz, AC only
Charge Rate	1 Hour
Torque	10 in.lb.

KNOW YOUR DRILL-DRIVER

See Figure 1.

Before attempting to use your drill-driver, familiarize yourself with all operating features and safety requirements.

 **WARNING:** Do not allow familiarity with your drill-driver to make you careless. Remember that a careless fraction of a second is sufficient to inflict severe injury.

KEYLESS CHUCK

Your drill-driver has a keyless chuck that allows you to hand tighten or release drill bit in the chuck jaws.

SWITCH

To turn your drill-driver ON, depress the switch trigger. Release switch trigger to turn your drill-driver OFF.

SWITCH LOCK

The switch trigger can be locked in the OFF position. This feature helps reduce the possibility of accidental starting when not in use.

VARIABLE SPEED

This tool has a variable speed switch that delivers higher speed with increased trigger pressure. Speed is controlled by the amount of switch trigger depression.

TWO SPEED GEAR TRAIN

Your drill-driver has a two speed gear train designed for drilling or driving at HI or LO speeds. A slide switch is located on top of your drill to select either HI or LO speed.

FORWARD/REVERSE SELECTOR

(DIRECTION OF ROTATION SELECTOR)

Your drill-driver has a forward/reverse selector located above the switch trigger.

WRIST STRAP

A wrist strap is provided to reduce the chances of dropping your drill-driver. Place one hand through the wrist strap when carrying tool.

BIT STORAGE

When not in use, bits provided with your drill-driver can be placed in the storage area located on the bottom of the motor housing.

LEVEL

To keep drill bit level during drilling operations, a level is located on the top and end of the motor housing.

 **WARNING:** If any parts are missing, do not operate your drill-driver until the missing parts are replaced. Failure to do so could result in possible serious personal injury.

FEATURES

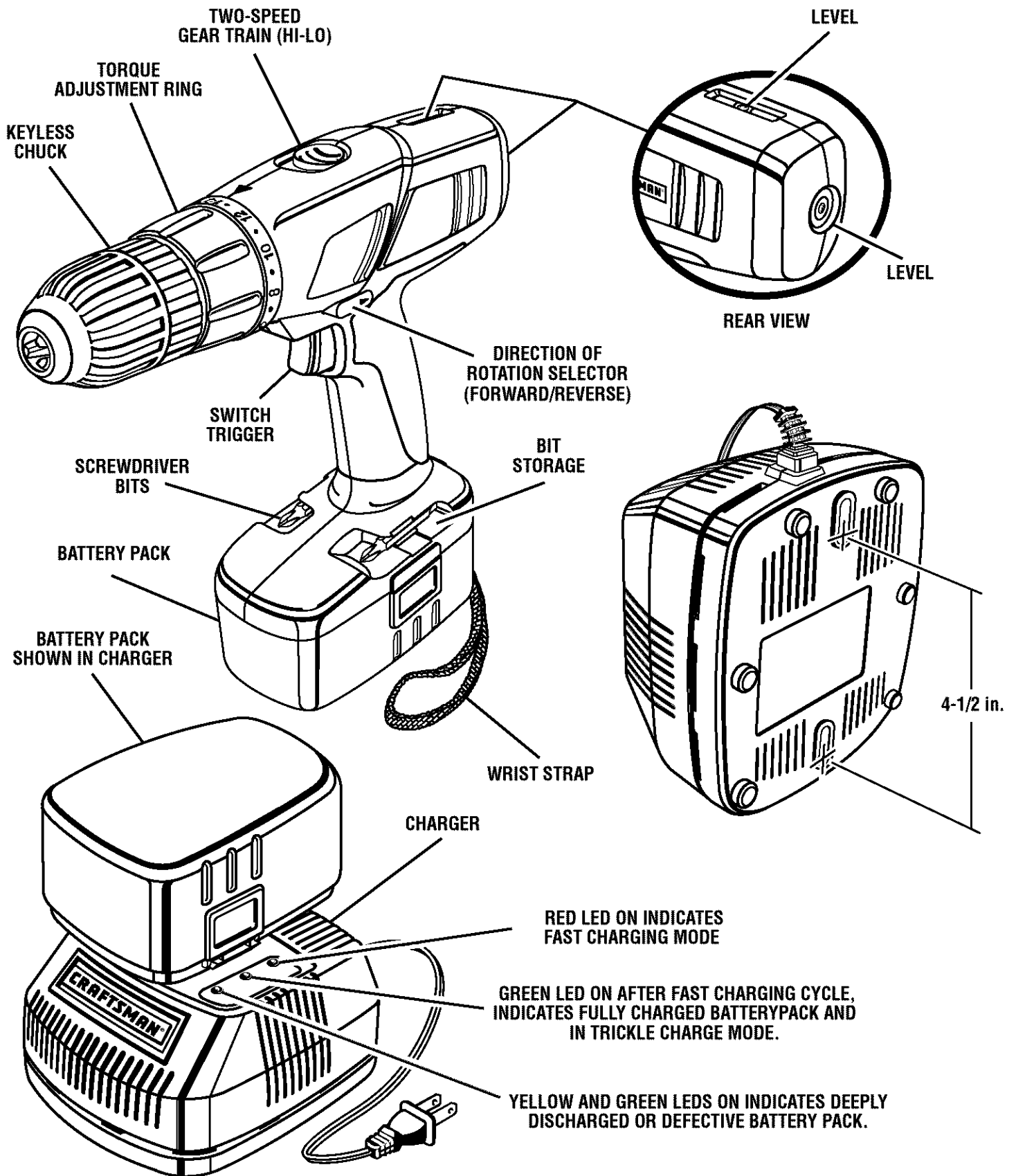

Fig. 1

UNPACKING

INSTRUCTIONS

When unpacking the tool:

- Carefully remove the tool and accessories from the box.
- Make sure that all items listed in the packing list are included.
- Inspect the tool carefully to make sure no breakage or damage occurred during shipping.
- Do not discard the packing material until you have carefully inspected and satisfactorily operated the tool.
- If any parts are damaged or missing, please call 1-800-932-3188 for assistance.

PACKING LIST

1/2 in. Drill
1 Hour Charger
Battery Pack (2)
Double-ended Bit (2)
Operator's Manual
Case



WARNING: If any parts are missing do not operate the tool until the missing parts are replaced. Failure to do so could result in possible serious personal injury.

OPERATION

WARNING: Do not allow familiarity with tools make you careless. Remember that a careless fraction of a second is sufficient to inflict severe injury.

BATTERY PACK

The battery pack for your tool has been shipped in a low charge condition to prevent possible problems. Therefore, you should charge it until light on front of charger changes from red to green.

Note: Batteries will not reach full charge the first time they are charged. Allow several cycles (drilling followed by recharging) for them to become fully charged.

CHARGING BATTERY PACK

See Figure 1.

- Charge battery pack only with the charger provided.
- Make sure power supply is normal household voltage, 120 volts, 60 Hz, AC only.
- Connect charger to power supply.
- Place battery pack in charger aligning raised rib on battery pack with groove in charger. See Figure 1.
- Press down on battery pack to be sure contacts on battery pack engage properly with contacts in charger.
- Normally, the red LED on charger will come on. This indicates charger is in fast charging mode.
- Red LED should remain on for approximately 1 hour then the green LED will come on. Green LED on indicates battery pack is fully charged and charger is in trickle charge mode. Note: Green LED will remain on until battery pack is removed from charger or charger is disconnected from power supply.
- If both yellow and green LED come on, this indicates a deeply discharged or defective battery pack.
- Allow battery pack to remain in charger for 15 to 30 minutes. When battery pack reaches normal voltage range, red LED should come on.
- If red LED does not come on after 30 minutes, this indicates a defective battery pack and should be replaced.
- After normal usage, a minimum of 1 hour of charging time is required to fully recharge battery pack.
- The battery pack will become slightly warm to the touch while charging. This is normal and does not indicate a problem.
- Do not place charger and battery pack in an area of extreme heat or cold. It will work best at normal room temperature.
Note: Charger and battery pack should be placed in a location where the temperature is more than 50°F but less than 100°F.
- When batteries become fully charged, unplug charger from power supply and remove the battery pack.

LED FUNCTIONS OF CHARGER LED WILL BE ON TO INDICATE STATUS OF CHARGER AND BATTERY PACK:

- Red LED on = Fast charging mode.
- Green LED on = Fully charged and in trickle charge mode.
- Green LED on = When battery pack is inserted into charger, indicates hot battery pack or that battery pack is out of or below normal temperature range.
- Yellow and Green LEDs on = Deeply discharged or defective battery pack.
- No LED on = Defective charger or battery pack.

CAUTION: To prevent damage to battery pack, remove battery pack from charger immediately if no LED comes on. Return battery pack and charger to your nearest Sears Service Center for checking or replacing. Also, if you are removing battery pack from charger and no LEDs are on, return both battery pack and charger to your nearest Sears Service Center. Do not insert another battery pack into charger. A damaged charger may damage a battery pack.

INFORMATION FOR RECHARGING HOT BATTERY PACK

When using your drill-driver continuously, the batteries in your battery pack will become hot. You should let a hot battery pack cool down for approximately 30 minutes before attempting to recharge. When the battery pack becomes discharged and is hot, this will cause the green LED to come on instead of the red LED. After 30 minutes, reinsert battery pack in charger. If green LED continues to remain on, return battery pack to your nearest Sears Repair Center for checking or replacing.

Note: This situation only occurs when continuous use of your drill causes the batteries to become hot. It does not occur under normal circumstances. Refer to "CHARGING BATTERY PACK" for normal recharging of batteries. If the charger does not charge your battery pack under normal circumstances, return both the battery pack and charger to your nearest Sears Repair Center for electrical check.

INFORMATION FOR RECHARGING COOL BATTERY PACK

If battery pack is below normal temperature range, the green LED on charger will come on. Allow battery pack to reach normal temperature, then the red LED will come on.

Note: Refer to "CHARGING BATTERY PACK" for normal recharging of batteries. If the charger does not charge your battery pack under normal circumstances, return both the battery pack and charger to your nearest Sears Repair Center for electrical check.

OPERATION

SWITCH

See Figure 2.

To turn your drill **ON**, depress the switch trigger. To turn it **OFF**, release the switch trigger.

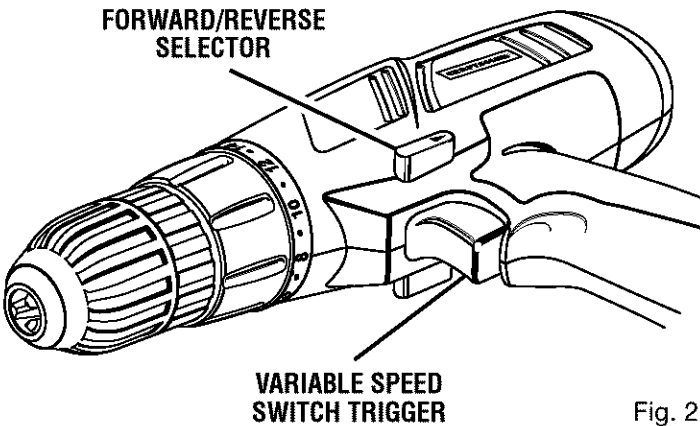

Fig. 2

VARIABLE SPEED

This tool has a variable speed switch that delivers higher speed and torque with increased trigger pressure. Speed is controlled by the amount of switch trigger depression.

Note: You might hear a whistling or ringing noise from the switch during use. Do not be concerned, this is a normal part of the switch function.

TWO-SPEED GEAR TRAIN

See Figure 3.

Your drill has a two-speed gear train designed for drilling or driving at LO (1) or HI (2) speeds. A slide switch is located on top of your drill to select either LO (1) or HI (2) speed. When using drill in the LO (1) speed range, speed will decrease and unit will have more power and torque. When using drill in the HI (2) speed range, speed will increase and unit will have less power and torque. Use LO (1) speed for high power and torque applications and HI (2) speed for fast drilling or driving applications.

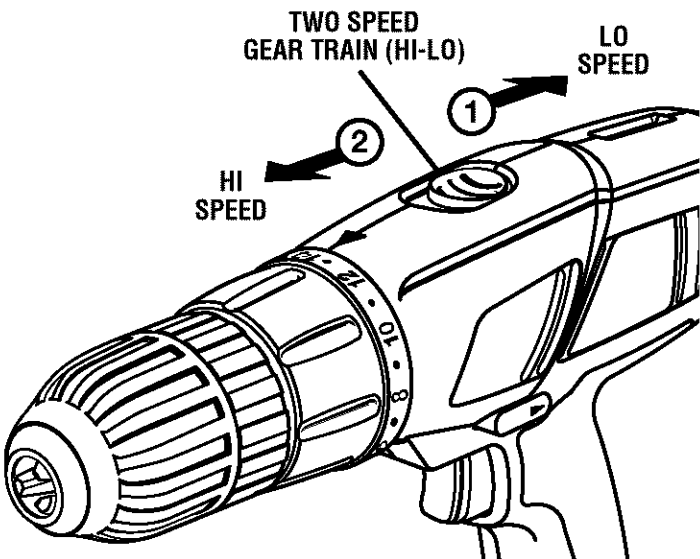

Fig. 3

TO INSTALL BATTERY PACK

- Lock switch trigger on your drill by placing the direction of rotation selector in center position. See Figure 5.
- Place battery pack in your drill. Align raised rib on battery pack with groove inside drill. See Figure 4.

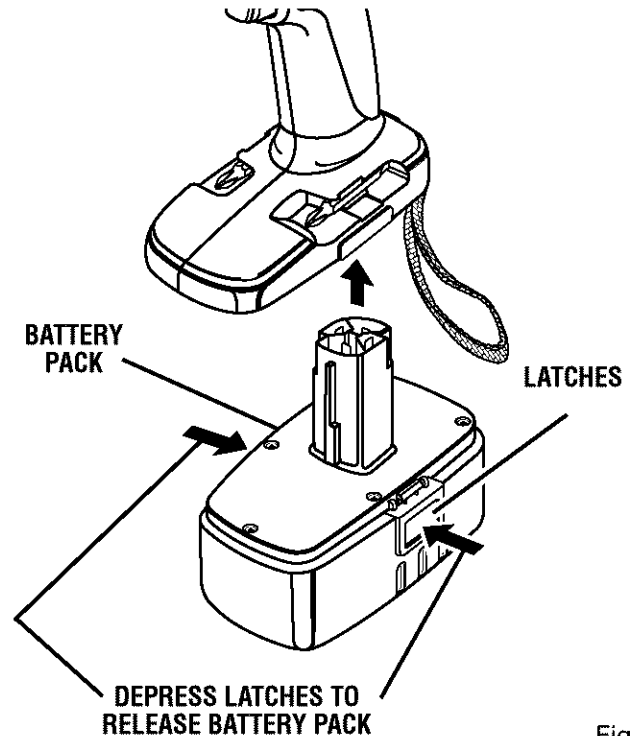

Fig. 4

- Make sure the latches on each side of your battery pack snap in place and battery pack is secured in drill before beginning operation.

CAUTION: When placing battery pack in your drill, be sure raised rib on battery pack aligns with groove inside drill and latches snap into place properly. Improper assembly of battery pack can cause damage to internal components.

TO REMOVE BATTERY PACK

- Lock switch trigger on your drill by placing the direction of rotation selector in center position. See Figure 5.
- Locate latches on side of battery pack and depress to release battery pack from your drill. See Figure 4.
- Remove battery pack from your drill.

OPERATION

SWITCH LOCK

See Figure 5.

The switch trigger can be locked in the **OFF** position. This feature can be used to prevent the possibility of accidental starting when not in use. To lock switch trigger, place the direction of rotation selector (Forward/Reverse Selector) in center position.

Note: When selector is in center position, switch trigger is locked.

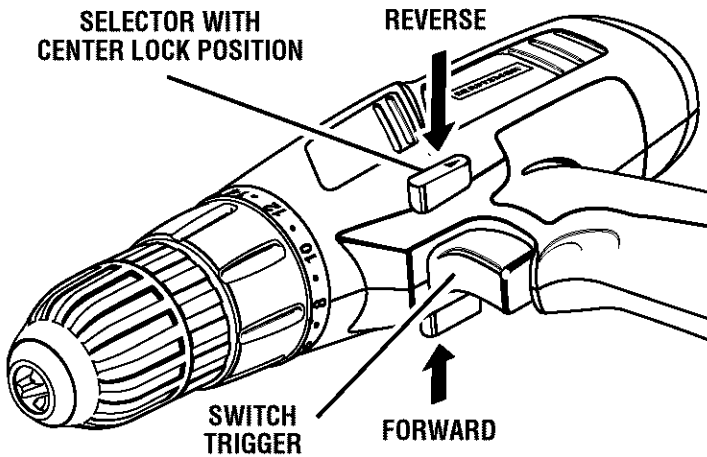

Fig. 5

WARNING: Battery tools are always in operating condition. Therefore, switch should always be locked when not in use or carrying at your side.

REVERSIBLE

See Figure 5.

This tool has the feature of being reversible. The direction of rotation is controlled by a selector located above the switch trigger. With the drill held in normal operating position, the direction of rotation selector should be positioned to the left of the switch for drilling. The drilling direction is reversed when the selector is to the right of the switch. When the selector is in center position, the switch trigger is locked.

CAUTION: To prevent gear damage, always allow chuck to come to a complete stop before changing the direction of rotation.

To stop, release switch trigger and allow the chuck to come to a complete stop.

KEYLESS CHUCK

See Figure 6.

Your drill has a keyless chuck. As the name implies, you can hand tighten or release drill bits in the chuck jaws. Grasp and hold the collar of the chuck with one hand. Rotate the chuck body with your other hand. The arrows on the chuck indicate which direction to rotate the chuck body in order to **LOCK** (tighten) or **UNLOCK** (release) the drill bit.

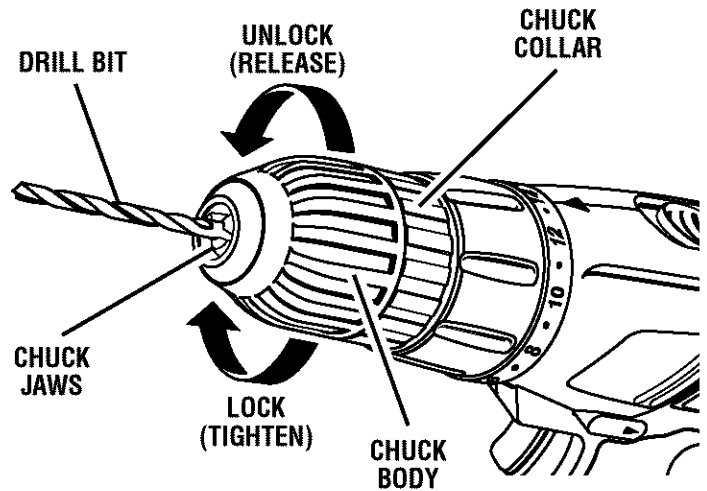

Fig. 6

WARNING: Do not hold chuck body with one hand and use power of the drill to tighten chuck jaws on drill bit. Chuck body could slip in your hand or your hand could slip and come in contact with rotating drill bit. This could cause an accident resulting in serious personal injury.

OPERATION

INSTALLING BITS

See Figure 7.

- Lock the switch trigger by placing the direction of rotation selector in center position. See Figure 5.
- Open or close chuck jaws to a point where the opening is slightly larger than the bit size you intend to use. Also, raise the front of your drill slightly to keep the bit from falling out of the chuck jaws.
- Insert drill bit straight into chuck the full length of the jaws as shown in figure 7.
- Tighten the chuck jaws on drill bit.

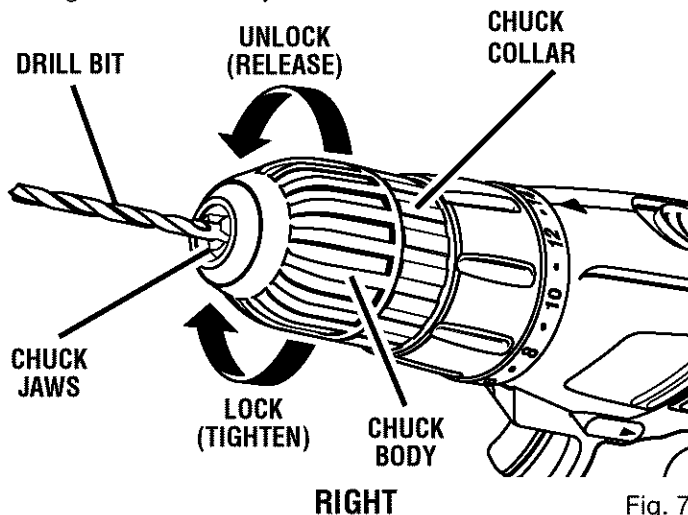

Fig. 7

- To tighten the chuck jaws on drill bit; grasp and hold the collar of the chuck with one hand, while rotating the chuck body with your other hand.

Note: Rotate the chuck body in the direction of the arrow marked **LOCK** to tighten chuck jaws.

- **Do not** use a wrench to tighten or loosen the chuck jaws.

⚠ WARNING: Make sure to insert drill bit straight into chuck jaws. Do not insert drill bit into chuck jaws at an angle then tighten, as shown in figure 8. This could cause drill bit to be thrown from drill, resulting in possible serious personal injury or damage to the chuck.

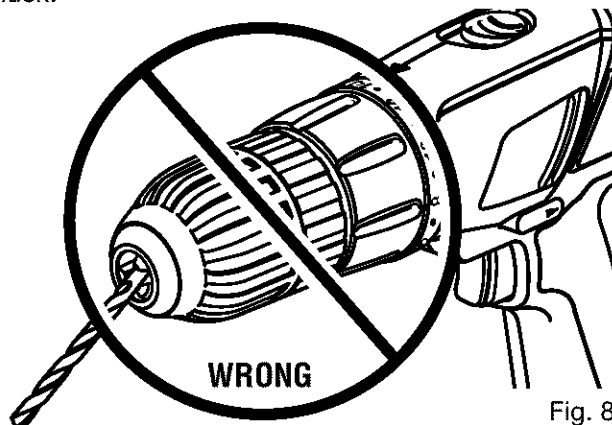

Fig. 8

REMOVING BITS

See Figure 7.

- Lock the switch trigger by placing the direction of rotation selector in center position. See Figure 5.
- Loosen the chuck jaws from drill bit.
- To loosen: grasp and hold the collar of the chuck with one hand, while rotating chuck body with your other hand. **Note:** Rotate chuck body in the direction of the arrow marked **UNLOCK** to loosen chuck jaws.
- **Do not** use a wrench to tighten or loosen the chuck jaws.
- Remove drill bit from chuck jaws.

ADJUSTABLE TORQUE CLUTCH

Your drill is equipped with an adjustable torque clutch for driving different types of screws into different materials. The proper setting depends on the type of material and the size of screw you are using.

TO ADJUST TORQUE

- Identify the twenty four torque indicator settings located on the front of your drill. See Figure 9.
- Rotate adjusting ring to the desired setting.
 - 1 - 4 For driving small screws.
 - 5 - 8 For driving screws into soft material.
 - 9 - 12 For driving screws into soft and hard materials.
 - 13 - 16 For driving screws in hard wood.
 - 17 - 20 For driving large screws.
 - 21 -  For heavy drilling.

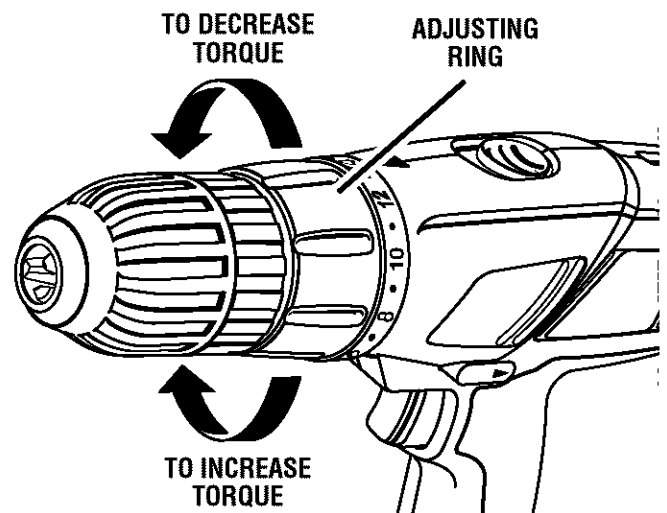

Fig. 9

OPERATION

BIT STORAGE

See Figure 10.

When not in use, bits provided with your drill can be placed in the storage area located on the bottom of your drill as shown in figure 10.

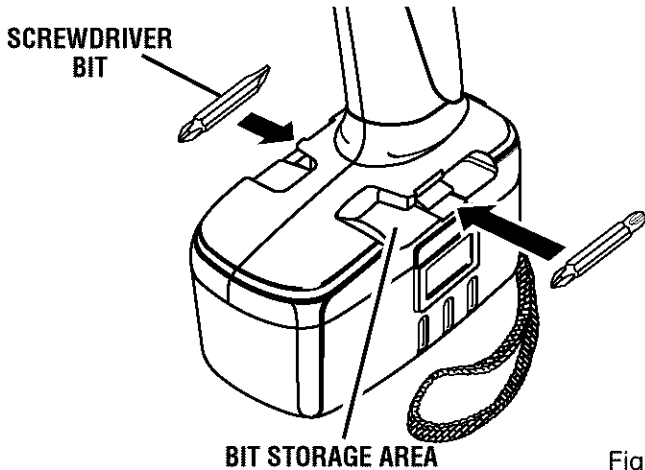

Fig. 10

WARNING: Always wear safety goggles or safety glasses with side shields when operating tools. Failure to do so could result in objects being thrown into your eyes, resulting in possible serious injury.

LEVEL

See Figure 11.

A convenient feature provided with your drill is a level. It is recessed in the motor housing on top and end of your drill. It can be used to keep drill bit level during drilling operations.

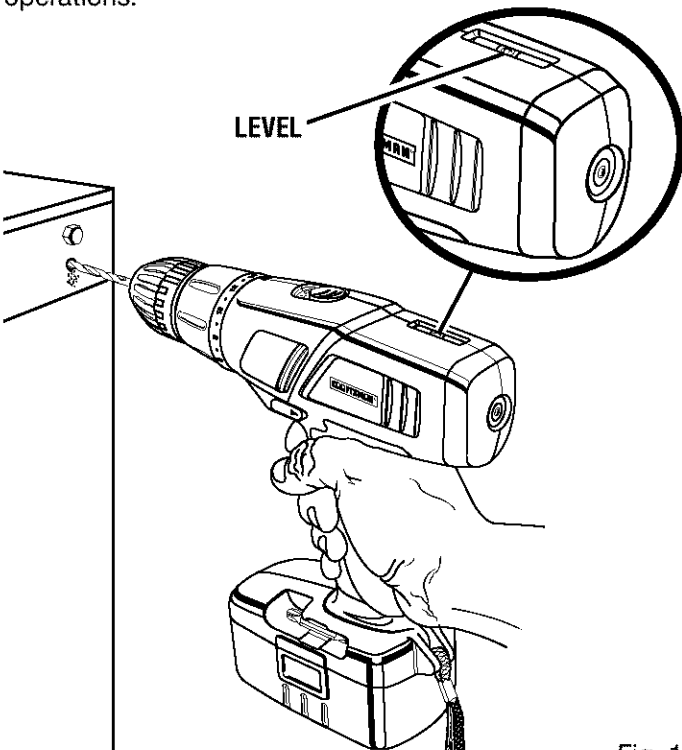

Fig. 11

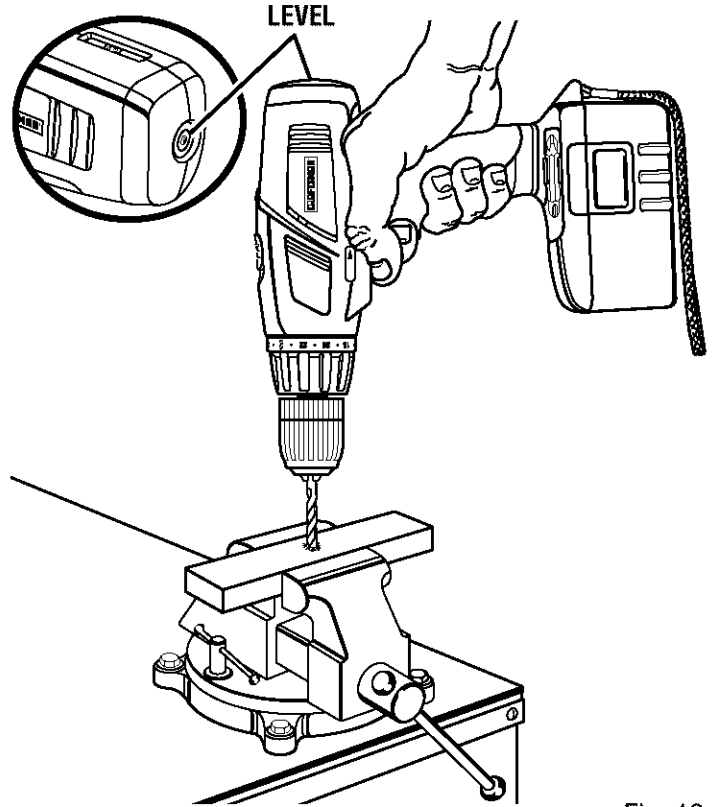

Fig. 12

DRILLING

See Figure 12.

When drilling hard smooth surfaces use a center punch to mark desired hole location. This will prevent the drill bit from slipping off center as the hole is started. However, the low speed feature allows starting holes without center punching if desired. To accomplish this, simply operate your drill at a low speed until the hole is started.

The material to be drilled should be secured in a vise or with clamps to keep it from turning as the drill bit rotates. Hold tool firmly and place the bit at the point to be drilled. Depress the switch trigger to start tool.

Move the drill bit into the workpiece applying only enough pressure to keep the bit cutting. Do not force or apply side pressure to elongate a hole.

WARNING: Be prepared for binding or bit breakthrough. When these situations occur, drill has a tendency to grab and kick opposite to the direction of rotation and could cause loss of control when breaking through material. If not prepared, this loss of control can result in possible serious injury.

When drilling metals, use a light oil on the drill bit to keep it from overheating. The oil will prolong the life of the bit and increase the drilling action.

If the bit jams in workpiece or if the drill stalls, release switch trigger immediately. Remove the bit from the workpiece and determine the reason for jamming.

OPERATION

CHUCK REMOVAL

See Figures 13, 14, and 15.

- Lock the switch trigger by placing the direction of rotation selector in center position. See Figure 5.
- Insert a 5/16 in. or larger hex key into the chuck of your drill and tighten the chuck jaws securely.
- Tap the hex key sharply with a mallet in a clockwise direction. See Figure 13. This will loosen the screw in the chuck for easy removal.

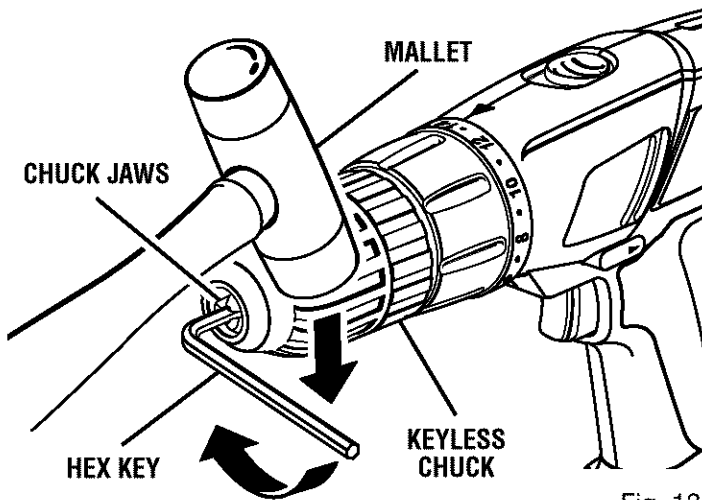

Fig. 13

- Open chuck jaws and remove hex key. Remove the chuck screw by turning it in a clockwise direction. See Figure 14.

Note: The screw has left hand threads.

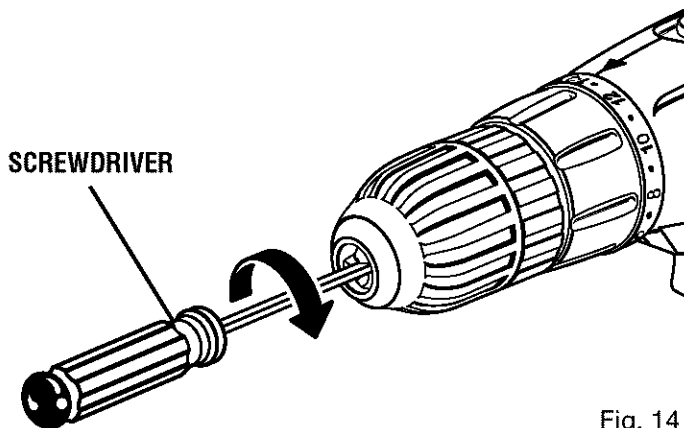

Fig. 14

- Insert hex key in chuck and tighten chuck jaws securely. Tap sharply with a mallet in a counterclockwise direction. This will loosen chuck on the spindle. It can now be unscrewed by hand. See Figure 15.

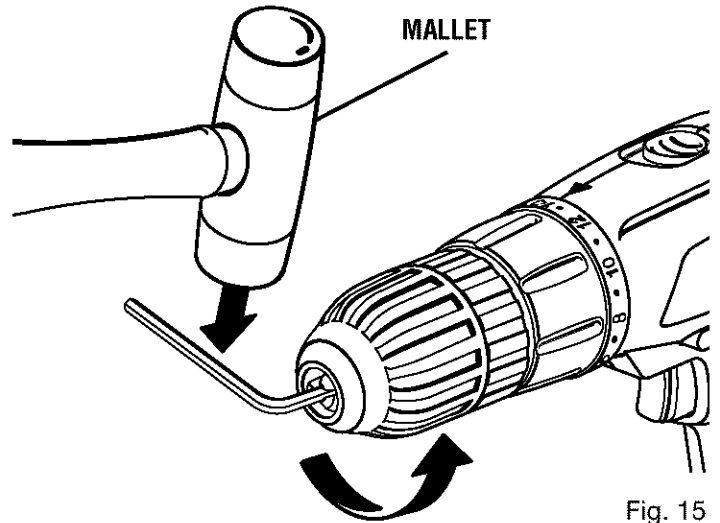

Fig. 15

TO RETIGHTEN A LOOSE CHUCK

The chuck may become loose on spindle and develop a wobble. Periodically check chuck screw for tightness.

To tighten, follow these steps:

- Lock the switch trigger by placing the direction of rotation selector in center position. See Figure 5.
- Open the chuck jaws.
- Insert hex key into chuck and tighten chuck jaws securely. Tap hex key sharply with a mallet in a clockwise direction. This will tighten chuck on the spindle.
- Open the chuck jaws and remove hex key.
- Tighten the chuck screw.

Note: The chuck screw has left hand threads.

MAINTENANCE

⚠ WARNING: When servicing, use only identical Craftsman replacement parts. Use of any other part may create a hazard or cause product damage.

Avoid using solvents when cleaning plastic parts. Most plastics are susceptible to damage from various types of commercial solvents and may be damaged by their use. Use clean cloths to remove dirt, dust, oil, grease, etc.

⚠ WARNING: Do not at any time let brake fluids, gasoline, petroleum-based products, penetrating oils, etc. come in contact with plastic parts. They contain chemicals that can damage, weaken or destroy plastic.

Do not abuse power tools. Abusive practices can damage tool as well as workpiece.

Only the parts shown on parts list, page 19, are intended to be repaired or replaced by the customer. All other parts should be replaced at a Sears Service Center.

⚠ WARNING: Do not attempt to modify this tool or create accessories not recommended for use with this tool. Any such alteration or modification is misuse and could result in a hazardous condition leading to possible serious personal injury.

BATTERIES

The battery pack for your drill-driver is equipped with nickel-cadmium rechargeable batteries. Length of service from each charging will depend on the type of work you are doing.

The batteries in this tool have been designed to provide maximum trouble free life. However, like all batteries, they will eventually wear out. Do not disassemble battery pack and attempt to replace the batteries. Handling of these batteries, especially when wearing rings and jewelry, could result in a serious burn.

To obtain the longest possible battery life, we suggest the following:

- Store and charge your batteries in a cool area. Temperatures below 50°F or above 100°F will shorten battery life.
- Never store batteries in a discharged condition. Recharge them immediately after they are discharged.
- All batteries gradually lose their charge. The higher the temperature the quicker they lose their charge. If you store your tool for long periods of time without using it, recharge the batteries every month or two. This practice will prolong battery life.



To preserve natural resources, please recycle or dispose of batteries properly.

This product contains nickel-cadmium batteries. Local, state or federal laws may prohibit disposal of nickel-cadmium batteries in ordinary trash.

Consult your local waste authority for information regarding available recycling and/or disposal options.

BATTERY PACK REMOVAL AND PREPARATION FOR RECYCLING

⚠ WARNING: Upon removal, cover the battery pack's terminals with heavy duty adhesive tape. Do not attempt to destroy or disassemble battery pack or remove any of its components. Nickel-cadmium batteries must be recycled or disposed of properly. Also, never touch both terminals with metal objects and/or body parts as short circuit may result. Keep away from children. Failure to comply with these warnings could result in fire and/or serious injury.

CRAFTSMAN 1/2 in., 19.2 VOLT CORDLESS DRILL-DRIVER – MODEL NO. 315.114850

The model number will be found on a plate attached to the motor housing. Always mention the model number in all correspondence regarding your 1/2 in., 19.2 VOLT CORDLESS DRILL-DRIVER or when ordering repair parts.

SEE BACK PAGE FOR PARTS ORDERING INSTRUCTIONS

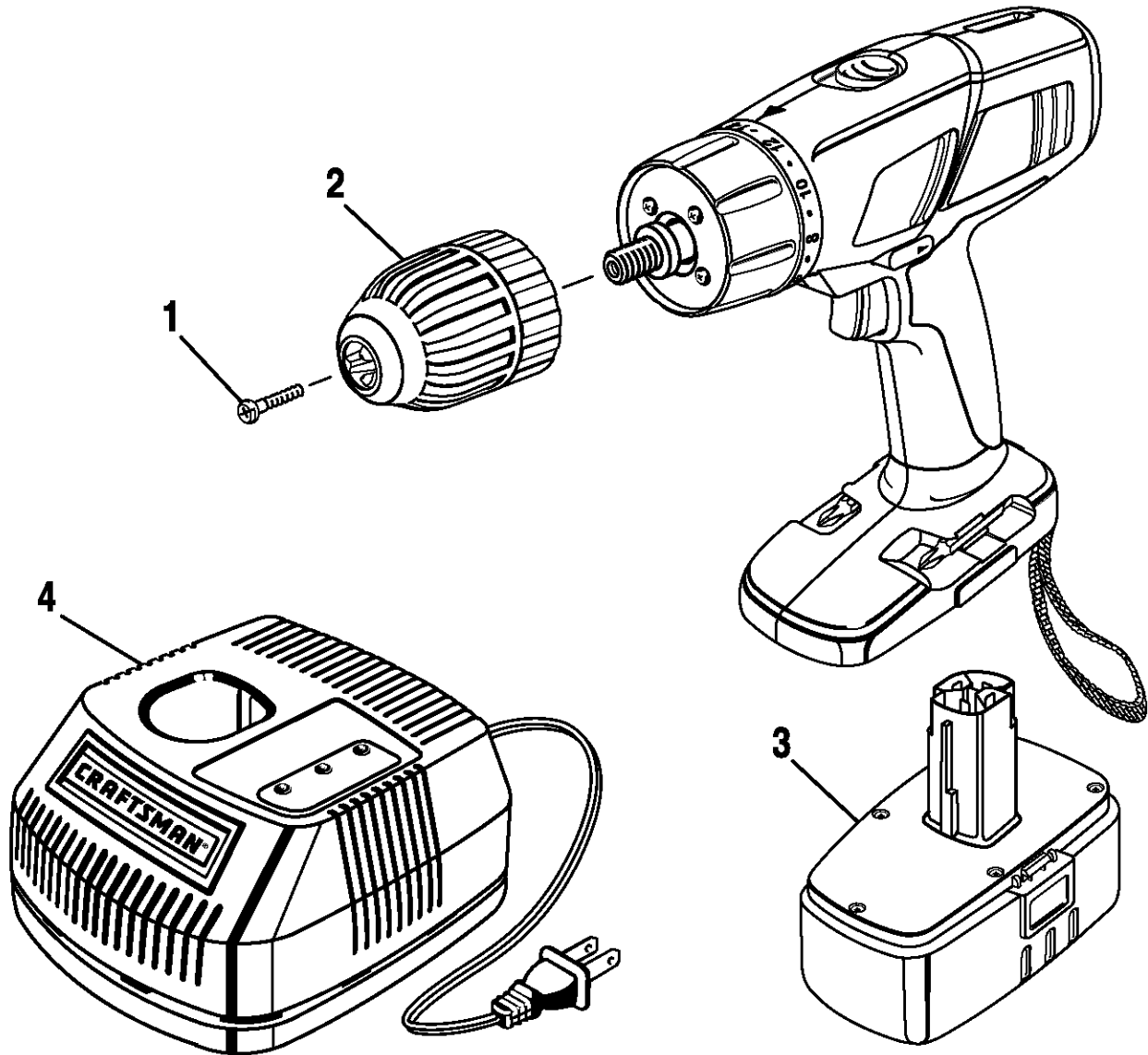

PARTS LIST

Key No.	Part Number	Description	Qty.
1	6613402	Screw (Special).....	1
2	6903323	Chuck	1
3	(1323517 or 1323903)	Battery Pack *Item No. 9 11375.....	1
4	(1425301)	Charger *Item No. 9 11041.....	1
	983000-464	Operator's Manual	

* Can Be Purchased Thru RSOS (Retail Special Order System)