

YARD KING

PERFORMANCE

This Instruction Book Contains Information
For Several Models. Read And Keep This Book For
Future Reference. This Book Contains Important Information On:
SAFETY, ASSEMBLY, OPERATION AND MAINTENANCE.

PRODUCT INFORMATION

The owner must be certain that all the product information is included with this unit.
This information includes the *INSTRUCTION BOOKS*, the *REPLACEMENT PARTS*
and the *WARRANTIES*. This information must be included to make
sure state laws and other laws are followed.

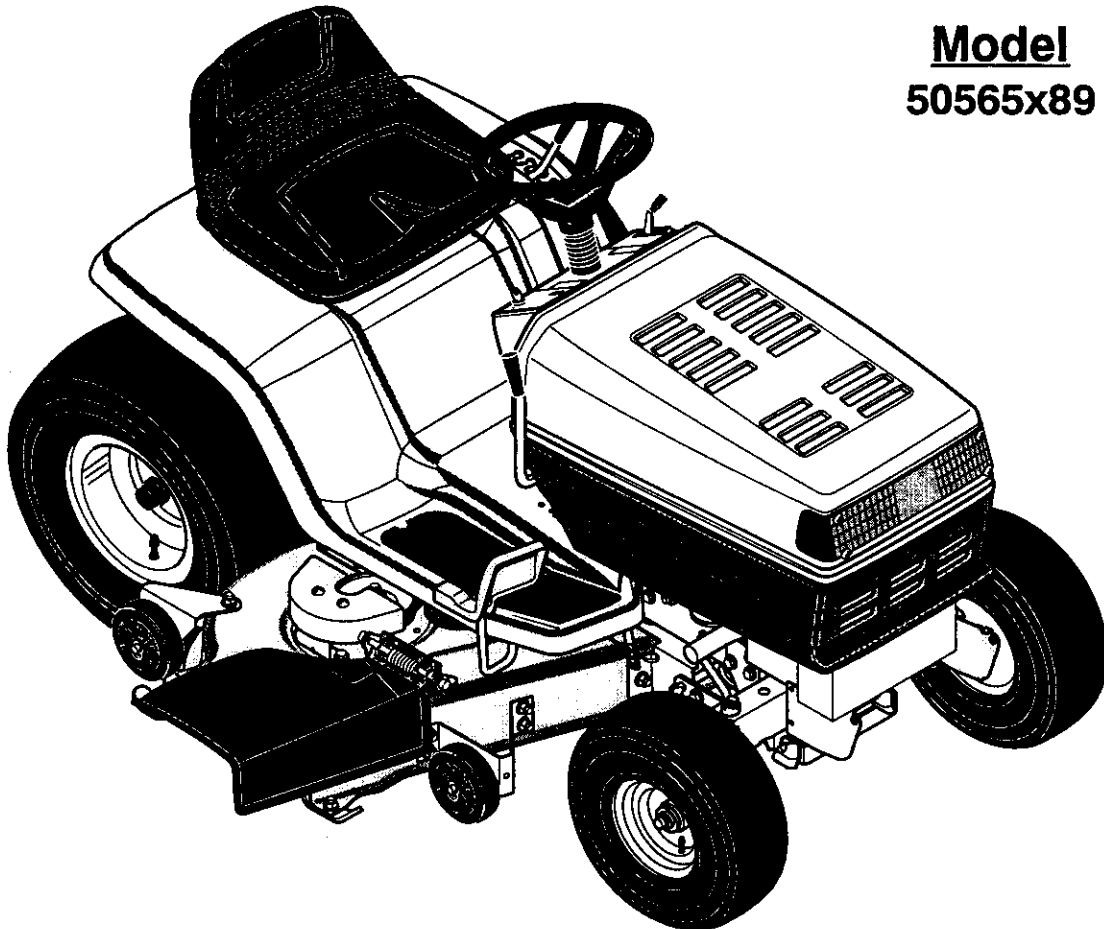

Model
50565x89

Record The Following Information About Your Unit. This Information
Is Necessary When Ordering Parts Or In Case Of Loss Or Theft.

WHERE PURCHASED: _____
DATE PURCHASED: Month _____ Day _____ Year _____
MODEL NO.: _____ DATE OF MANUFACTURE: _____



BUILT IN THE

USA

TABLE OF CONTENTS

WARRANTY	2	HOW TO CHECK THE MUFFLER	18
RESPONSIBILITY OF THE OWNER	3	HOW TO REMOVE AND INSTALL THE BLADE	19
SAFETY RULES	3	HOW TO SHARPEN THE BLADE	19
BEFORE YOU MOW	9	HOW TO ADJUST THE BLADE ROTATION CONTROL	20
ASSEMBLY	9	HOW TO CHECK AND ADJUST THE DRIVE BRAKE	21
CHECK THE TIRES	9	HOW TO CHECK AND ADJUST THE MOTION DRIVE BELT ..	21
CHECK THE LEVEL OF THE MOWER HOUSING	9	HOW TO ADJUST THE SPEED CONTROL PEDAL	22
MAINTENANCE FREE BATTERY	9	MAINTENANCE FREE BATTERY	22
HOW TO PREPARE THE ENGINE	10	HOW TO CHARGE THE BATTERY	22
IMPORTANT! BEFORE YOU START MOWING	10	WHERE TO LUBRICATE	23
OPERATION	11	HOW TO OPERATE THE QUICK RELEASE OIL DRAIN VALVE	23
LOCATION OF CONTROLS	11	HOW TO CHECK THE FUEL FILTER	23
ATTACHMENTS	12	CHECK THE TIRES	23
HOW TO USE THE THROTTLE CONTROL	12	HOW TO REMOVE THE MOWER HOUSING	24
HOW TO USE THE BLADE ROTATION CONTROL	12	HOW TO INSTALL THE MOWER HOUSING	24
HOW TO USE THE SPEED CONTROL PEDAL	13	HOW TO ADJUST THE GAUGE WHEELS	25
HOW TO DISCONNECT THE TRANSMISSION	13	HOW TO LEVEL THE MOWER HOUSING	26
HOW TO SET THE PARKING BRAKE	14	HOW TO REPLACE THE MOTION DRIVE BELT	27
HOW TO CHANGE THE CUTTING HEIGHT	14	HOW TO REPLACE THE MOWER DRIVE BELTS	28
HOW TO STOP THE UNIT	14	HOW TO REPLACE THE FUSES	29
HOW TO TRANSPORT THE UNIT	14	HOW TO REPLACE THE LIGHT BULB	29
HOW TO OPERATE WITH THE MOWER HOUSING	15	HOW TO REPLACE THE LIGHT BULB	29
HOW TO OPERATE THE UNIT ON HILLS	15	HOW TO CLEAN THE MOWER HOUSING	29
BEFORE STARTING THE ENGINE	16	STORAGE (OVER 30 DAYS)	29
HOW TO START THE ENGINE	16	TROUBLE SHOOTING CHART	30
OPERATING TIPS	17	SLOPE GUIDE	31
MOWING AND BAGGING TIPS	17	REPAIR PARTS	32
MAINTENANCE	18	LAWN TRACTOR ACCESSORIES	59
MAINTENANCE CHART	18	HOW TO ORDER REPAIR PARTS	60

YARDKING PERFORMANCE Two Year Limited Warranty

Yardking Performance warrants to the original purchaser that this unit shall be free from defects in material and workmanship under normal use and service for a period of **Two (2) Years** from the date of purchase; however, this warranty does not cover engines, accessories (such as snow blowers, snow blades, grass baggers and plows), transmissions, batteries and Normal Wear Parts (except as noted below) or transaxles as the companies that manufacture these items furnish their own warranties and provide service through their authorized field service facilities. For additional information, see the warranties covering these particular parts. If you are uncertain whether your unit contains or is equipped with one or more of these parts, consult your dealer prior to purchase. Subject to the terms and conditions noted in this Limited Warranty, we shall, at our option, repair or replace at no cost to the original purchaser any part covered by this Limited Warranty during the applicable warranty period.

In the event the battery proves defective within ninety (90) days from the date of purchase, we will replace it without charge. If the battery proves defective after (90) days but within one hundred twenty (120) days from the date of purchase, we will replace it for a charge of one half (1/2) of the retail price of the battery in effect at the time of return.

Normal Wear Parts are defined as belts, blades, blade adapters, pneumatic tires, headlights and seat covers. These parts are warranted to be free from defects in material and workmanship as delivered with the product. Any claim for repair or replacement of Normal Wear Parts must be made within thirty (30) days of the date of purchase. No claims involving damage caused from material use, abuse or misuse will be honored.

This **Yardking Performance Two (2) Year Limited Warranty** is your exclusive remedy; however, this warranty is void or does not apply to any unit that has been tampered with, altered, misused, abused or used for rental or other commercial and/or professional (non-homeowner) uses. Your warranty does not cover minor mechanical adjustments which are not due to any defect in material or workmanship. For assistance in making such adjustments, consult your Instruction Book.

To make a claim under this **Yardking Performance Two (2) Year Limited Warranty**, return the unit (or if authorized in advance, the defective part) along with your proof of purchase to an Authorized Service Center near you. To locate the nearest Authorized Service Center, call the Central Parts Distributor for your area shown in the list provided with your unit or check the Yellow Page listings in your local telephone directory. If you return the entire unit, we will repair the unit. If we authorize the return of the defective part only, we will either replace or repair the part. In the case of a defect in a transmission or differential (as distinguished from a transaxle), the entire transmission or differential must be returned since they do not include user serviceable parts.

This **Yardking Performance Two (2) Year Limited Warranty** gives you specific legal rights, and you may also have other rights which vary from state to state. **This Limited Warranty is given in lieu of all other expressed and implied warranties including the implied warranty of merchantability and warranty of fitness for a particular purpose.** If you need additional information on this written warranty or assistance in obtaining service, write or call: **Yardking Performance, Outdoor Power Equipment, Customer Service Department, P.O. Box 268, Brentwood, Tennessee 37027. (1-800-289-8995)**

OWNER'S INFORMATION

This instruction book is for several different models. The instructions are written for a person with some mechanical ability. Like most service books, not all the steps are described. Steps on how to loosen or tighten fasteners are steps anyone can follow with some mechanical ability. Read and follow these instructions before you use the unit.

Know your product: If you understand the unit and how the unit operates, you will get the best performance. As you read this manual, compare the illustrations to the unit. Learn the location and the function of the controls. To help prevent an accident, follow the operating instructions and the safety rules. Keep this manual for future reference.

IMPORTANT: Many units are not assembled and are sold in cartons. It is the responsibility of the owner to make sure the assembly instructions in this manual are exactly followed. Other units are pur-

chased in an assembled condition. On assembled units, it is the responsibility of the owner to make sure the unit is correctly assembled. The owner must carefully check the unit according to the instructions in this manual before it is first used.

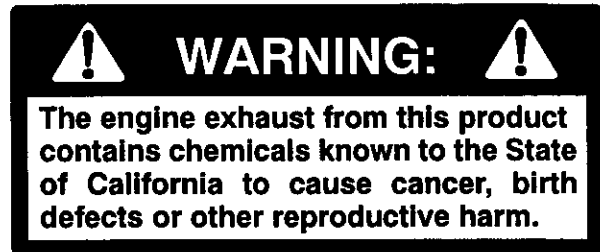

RESPONSIBILITY OF THE OWNER

The responsibility of the owner is to follow the instructions below.

1. Carefully read and follow the rules for safe operation.
2. Follow all the assembly instructions.
3. Inspect the unit.
4. Make sure that the operator of the unit knows how to correctly use all standard and accessory equipment.
5. Operate the unit only with guards, shields, and other safety items in place and working correctly.
6. Correctly adjust the unit.
7. Service the unit only with authorized or approved replacement parts.
8. Complete all maintenance on the unit.

Environmental Awareness

- Do not fill the engine's fuel tank completely full.
- Drain fuel for off-season storage.
- Use only unleaded gasoline.
- Service the air cleaner regularly.
- Change oil regularly. Use 30W oil in summer.
- Change oil regularly. Use 10W-30 oil in winter.
- Tune-up the engine regularly.
- Keep equipment in efficient operating condition.
- Dispose of used engine oil properly.

SAFETY RULES

Safe Operation Practices for Ride-on Mowers

 **WARNING:** This cutting machine is capable of amputating hands and feet and throwing objects. Failure to observe the following safety instructions could result in serious injury or death.

I. General operation

1. Read, understand and follow all instructions in the Instruction Book, on the machine, the engine and with any attachments before starting.
2. Only allow responsible adults, who are familiar with the instructions, to operate the machine.
3. Clear the area of objects such as rocks, toys, wire, etc., which could be picked up and thrown by the blade.
4. Be sure the area is clear of other people before mowing. Stop the machine if anyone enters the area.
5. Never carry passengers.
6. Turn off power to the blades or any attachments before backing up. Do not mow in reverse unless absolutely necessary. Always look down and behind before and while backing.
7. Be aware of the mower discharge direction and do not point it at anyone. Do not operate the mower without either the entire grass bagger or the mower guard in place.
8. Slow down before turning.
9. Never leave a machine unattended with the engine running. Always turn off the blade(s), set the parking brake, stop the engine and remove the key before dismounting.
10. Turn off power to attachment(s) when transporting or not in use. Turn off the blade(s) when not mowing.
11. Stop the engine before removing the grass bagger or unclogging the chute.
12. Mow only in daylight or good artificial light.
13. Do not operate the machine while under the influence of alcohol or drugs or when very tired.
14. Watch for traffic when operating near or crossing roadways.
15. Use extra caution when loading or unloading the machine into a trailer or truck.
16. Turn off all attachment clutches before attempting to start the engine.
17. Always wear goggles, safety glasses, or an eye shield when you operate the unit to protect your eyes from foreign objects that can be thrown from the unit. Always wear eye protection when you make an adjustment or repair to the machine.
18. Use care when pulling loads or using heavy equipment.
 - a. Use only approved drawbar hitch points.
 - b. Limit loads to those you can safely control.
 - c. Do not turn sharply. Use care when backing.
 - d. Use counterweights or wheel weights when suggested in the Instruction Book.
19. Do not operate this machine if you are taking drugs or other medication which can cause drowsiness or affect your ability to operate this machine.

OWNER'S INFORMATION

20. Do not use this machine if you are mentally or physically unable to operate this machine safely.

II. Slope operation

Slopes and rough terrain are major factors related to loss-of-control and tip-over accidents, which can result in severe injury or death. ALL slopes require extra caution. If you cannot back up the slope or if you feel uneasy on the slope, do not mow it. See the "Slope Guide" in the back of this book to check for safe operation.

DO

1. Mow up and down slopes, not across.
2. Remove obstacles such as rocks, limbs, etc...
3. Watch for holes, ruts or bumps. Uneven terrain could overturn the machine. *Tall grass can hide obstacles.*
4. Use slow speed on slopes. Do not make sudden speed changes.
5. Follow the manufacturer's recommendations for wheel weights or counterweights to improve stability.
6. Use extra care with grass baggers or other attachments, they can change the stability of the machine.
7. Keep all movement on the slopes **slow and gradual**. Do not make sudden changes in speed or direction.
8. Avoid starting or stopping on a slope. If tires lose traction, turn off the blades and proceed slowly **straight down** the slope.

DO NOT

1. **Do not** turn on slopes unless absolutely necessary, then only turn slowly and gradually downhill, if possible.
2. **Do not** mow drop-offs, ditches or embankments. A wheel over the edge or an edge caving in could cause a sudden overturn and an injury or death.
3. **Do not** mow on wet grass. Reduced traction could cause sliding.
4. **Do not** try to stabilize the machine by putting your foot on the ground.
5. **Do not** use a grass bagger or other rear mounted accessories on steep slopes (greater than 10 degrees).

III. Children

Tragic accidents can occur if the operator is not alert to the presence of children. Children are often attracted to the machine and the mowing activity. NEVER assume that children will remain where you last saw them.

1. Keep children out of the mowing area and in the watchful care of another responsible adult.
2. Be alert and turn the engine off if children enter the area.
3. Before and when backing, look **behind and down** for small children.
4. Never carry children or any passengers, even with the blades off. They may fall off and be seriously injured or interfere with the safe operation of the machine.
5. Never allow children to operate the machine. Instruct children in the potential dangers of the machine.
6. Use extra care when approaching blind corners, shrubs, trees or other objects that may obscure vision.

IV. Service

1. Use extra care when handling gasoline and other fuels. Fuels are flammable and the vapors are explosive.
 - a. Use only an approved container.
 - b. Never remove the gas cap or add fuel with the engine running. Allow the engine to cool for several minutes before refueling. Do not smoke.
 - c. Never refuel the machine indoors.
 - d. Never store the machine with fuel in the tank or fuel container inside where there is an open flame, such as a water heater.
2. Never start or run the engine inside a closed area.
3. Keep all nuts and bolts, especially the blade attachment nuts tight. Frequently check the blade(s) for wear or damage such as cracks and nicks. A blade that is bent or damaged must be immediately replaced with an original equipment blade from an authorized service dealer. For safety, replace the blade every two years. Keep the equipment in good condition.
4. Never tamper with the safety devices. Check their proper operation regularly.
5. To reduce fire hazards, keep the machine free of grass, leaves or other debris build-up. Clean up oil or fuel spills. Allow the machine to cool before storing.
6. Stop and inspect the equipment if you strike an object. Repair, if necessary, before restarting.
7. Never make adjustments or repairs with the engine running. The carburetor can be adjusted with the engine running. Do not change the engine governor settings or over-speed the engine.
8. Grass bagger components are subject to wear, damage and deterioration, which could expose moving parts or allow objects to be thrown. For storage, always make sure the grass bag is empty. Frequently check components and replace with manufacturer's recommended parts when necessary.
9. Mower blade(s) are sharp and can cut. Wrap the blade(s) or wear gloves and use extra caution when servicing them or the blade housing area.
10. Check the brake operation frequently. Adjust and service as required.
11. Wait for all movement to stop before servicing any part of the unit.



Look for this symbol to indicate important safety precautions. This symbol indicates: "Attention! Become Alert! Your Safety Is At Risk."

SAFE MOWING GUIDE

Each person that operates power equipment must learn to use correct and safe mowing procedures. **To help you learn, carefully read the following pages.** Most of the time the operator was not correctly shown or did not read the instructions on the unit or in the Instruction Book before using the unit. Also, some operators do not have enough experience. The result is unsafe use, endangering the operator, bystanders and the equipment. Another result can be a poor appearance of the area mowed.

Read this book. Read the instructions on the unit. Operate the mower according to the Safe Mowing Guide. Follow all safety rules, cautions or warnings in this book and on the unit. Make sure anyone that uses the unit reads the instructions and is told how to safely operate the mower.

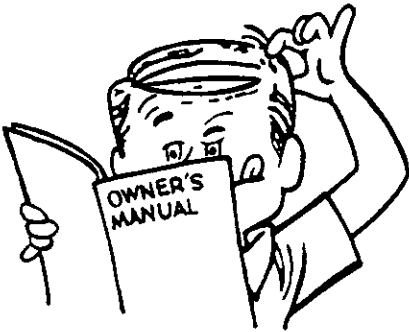

The mower will give you good service and durability, if operated in normal conditions. If the mower is not correctly serviced or is used where the terrain is rough or unsuitable, product performance and safety will be decreased.

Correct clothing is an important part of safe mowing. Safety glasses will protect the eyes from objects discharged by the mower. Safety shoes with steel plates can protect a foot from injury by the blade. For protection from objects discharged from the mower, wear clothing that will cover the arms and legs.

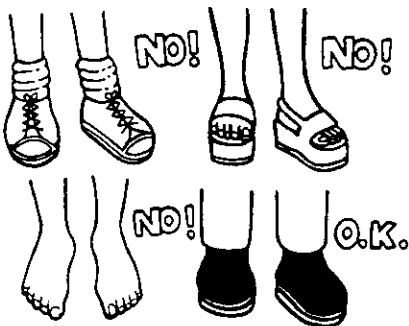

Before you start cutting the grass, practice using the mower in a large open and level area. Learn the location of the controls on the mower. Know the purpose of the

controls and how they work. In an emergency, how fast you can stop the blade is important. Learn how to control the mower at all times.

Many engines are started by hand. When you use a pull start or rope start, place your feet apart and away from the blade(s). Hold the rope handle tight. Never wrap the rope around your arm or fingers for a "better grip". To start the engine, follow the instructions on the mower, in this book and in the engine operating instructions.

For electric start engines, sit in the seat to start the engine. The battery can be dangerous. Follow the instructions on the battery, the acid container, and in this book when working with the battery. Even small batteries have enough voltage to cause an injury. Always be careful.

The mower is designed to be operated by one person. Never let another person ride with you on the unit or on any accessories. A passenger will make the unit harder to control, block the visibility or distract the operator and is dangerous to the operator, the passenger and the equipment. Without a passenger seat, the passenger can fall from the mower or contact dangerous parts. A mower is not a toy for showing off or for giving rides.

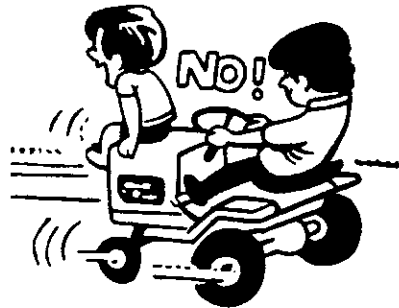

Never cut a wet lawn. Wet grass can cause an accident, affect mower performance and can cause problems with future lawn growth and appearance. Wet grass is slippery and can cause the mower to slip. Someone can get injured by touching the blade(s). Wet grass tends to clog the mower, causing poor discharge. Cut wet grass will collect on the lawn, retarding the growth of the grass. Also, getting the mower wet will cause parts to rust and decrease the life of the unit.

When you look over the lawn, remember obstacles that cannot be removed, like pipes, stumps or rocks. Keep away from these obstacles that can cause damage to the mower or injury to the operator or a person near the mower. Clear the area of rocks, toys, wire or other loose objects. These items can damage the mower or can be discharged by the mower blade.



The blade of a power mower rotates very fast. It can discharge rocks and other objects over a long distance which can be dangerous. The force of the objects can break windows, cause injuries or even put an eye out. Most of the time the injury is to a person, like a child. Keep every person completely away from the area to be mowed. Make sure the grass is not discharged toward anyone. Planning your mowing pattern has a double advantage. It can decrease the possibility of an injury and make the clean up after mowing easier.

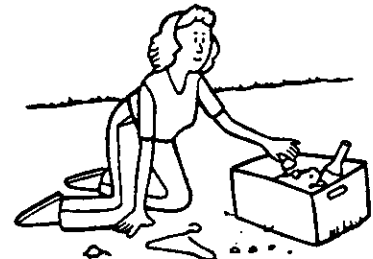

Check the terrain of the area to be mowed. Mow in a pattern that will keep you away from dangerous areas. Check the distance you need to stop and the distance available to turn. Slopes and rough terrain must be mowed carefully and some areas must not be mowed at all. With riding mowers, mow up and down the hill. When you must mow rough terrain or on slopes, drive slowly and stop in these areas only in an emergency. Before you ride up or down a slope, try to back straight up the slope. Do not ride up or down a slope that is too steep to back straight up. See the "Guide" in the back of this Instruction Book to check any slopes.

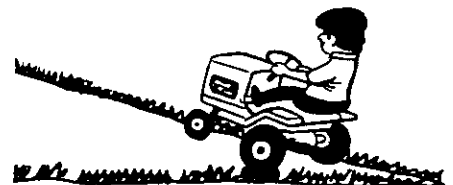

Before you start cutting, make sure the mower was completely assembled according to the Instruction Book. If the mower was completely assembled at the

SAFE MOWING GUIDE

store, you must still check the mower according to the assembly instructions. Make sure the mower is correctly assembled and that all fasteners are tight. Make sure the engine has the correct amount of oil. Check these items often during the life of the mower.

Your mower has a gasoline engine. Gasoline is a dangerous fuel. Keep gasoline only in an approved safety gasoline container. Do not keep large amounts of gasoline. When you add gasoline to the fuel tank, do not smoke. Store the gasoline container and the mower in an area that has good ventilation. Also, keep the gasoline away from any flames like the pilot light of a furnace or any other source of ignition. If the mower is to be stored for more than a few weeks, remove the gasoline from the fuel tank. When inside an enclosure, do not add gasoline to the fuel tank. Before you add gasoline, move the mower outside and add gasoline carefully. Before you start the engine, remove any gasoline from the outside of the fuel tank or from the mower. Warm gasoline will expand. Leave some space in the fuel tank for the gasoline to expand. Also, the fuel cap has a vent hole for fuel vapors. Always use the correct fuel cap. Failure to follow safety rules about gasoline will cause fires and explosions, injury to you and damage to the equipment and other property.

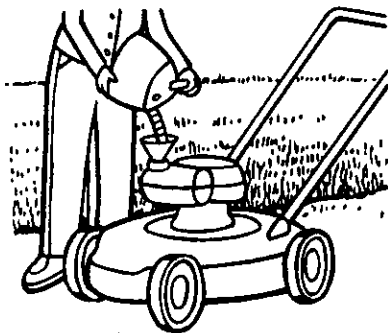

If you add gasoline to an engine that is running or hot, the result can be an explosion. Before you add gasoline, stop the engine and let the engine cool for several minutes. Remove dry grass and other debris from the mower. Keep the mower clean to improve the performance, help the engine and transmission run cooler, extend the life of moving parts, and decrease the danger of a fire.

Fires and explosions are not the only dangers when working around a mower. The engine, transmission, and the muffler will get hot in several minutes when the engine is running. Do not touch these parts of the mower. Stop the engine. Let the

engine and transmission cool before servicing the mower. Remember, exhaust fumes are dangerous. Never operate the engine inside a building.

When you get a new mower, it can be a new experience for the family. Tell each person how a mower can be dangerous. Remember, a mower is not a toy. A mower is not to be used by children or anyone not old enough, strong enough or that does not have experience.

If the mower is not correctly assembled, not operated correctly, or not regularly serviced, the mower can be dangerous. The most important rule to follow is always use good judgement and common sense. Mow safely and carefully.

Your mower will easily cut thick grass. Fingers, feet and other parts can also be cut by the blade. Injuries occur when the operator does not think and reaches into the chute opening. Always operate the mower as if the blade is rotating. Do not service or make an adjustment, except to the carburetor, while the engine is running.

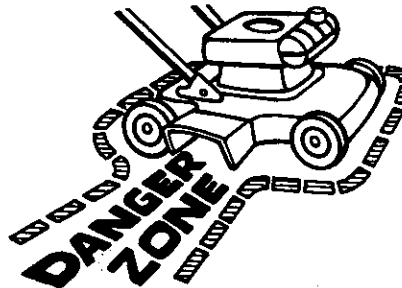

Use only accessories that are factory approved for your mower. The wrong accessory can decrease the safety of the mower and can even damage the unit. Read and follow the instructions included with the accessory and the mower.

Use only original equipment or replacement parts that are factory approved for service. If you need service, select an Authorized Service Center for your mower. If you do the work on the unit, follow the instructions in the Instruction Book.

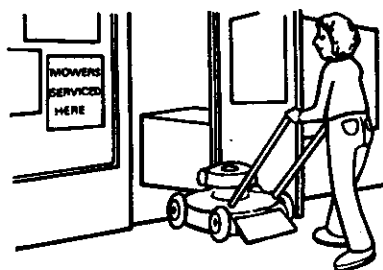

When you mow, remember that children are attracted to the mower. Always use caution when mowing around obstacles like trees or shrubs or when moving backward. Only mow in a forward direction if possible. Your visibility is decreased when you mow backward. Also, the blades are made to cut while the unit is moving forward. If you mow backward, the cutting performance decreases.

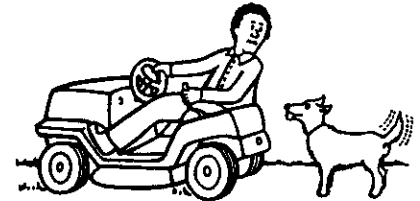

Before you leave the mower, stop the engine. Remove the key. Disengage and lower any attachment. Set the parking brake. Never mount or dismount from the seat while the engine is running. An accident can occur if you touch the brake, speed control pedal, throttle, or blade control while the engine is running. Mount and dismount from the seat on the side of the unit that is marked ENTER-EXIT.

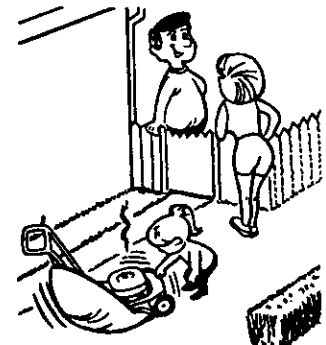

Make sure you are in good condition when you mow. When you mow for several hours your reflexes will decrease and your mind will not be as alert. Take a short break or an accident can occur. If the temperature is hot, use caution to prevent dehydration. If you are tired, angry or not completely alert, do not operate the mower. If you use alcohol, medication or drugs, do not use the mower or any type of power equipment.

Engine speed is a key to safe mowing and to a good looking lawn. The maximum speed of the engine was set at the factory. Do not change the setting of the engine governor.

Select the maximum engine and ground speed that is right for the terrain and the height of the grass. The blade cuts best when the engine is operating at maximum speed. The engine and transmission will also run cooler at maximum engine speed.

SAFE MOWING GUIDE

Also, the grass bagger will function better when the engine is operating at maximum speed. On slopes, decrease the ground speed and use care making sure the mower feels safe to operate.

If the weather conditions are bad, do not mow. If weather conditions become bad, stop cutting and finish later. It is dangerous to cut grass in the rain. Always find protection in an electrical storm. If the weather conditions are extra dry, protect your eyes with safety glasses from the dust and from the objects discharged by the mower. Also, a dust or a pollen mask can help.

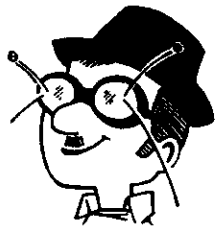

Your mower is equipped with a number of safety devices which are important to the safety of the operator and bystanders and must never be changed or removed from the mower. If a safety device is lost, damaged or no longer functions, repair or replace the device before you operate the mower.

It is best to mow during the day. If you must mow at night, make sure there is enough light for safe operation.

Your mower will require regular maintenance and service. The maintenance schedule depends on the hours of use. Also, mowing conditions can change the schedule. Check the Instruction Book for more information. Correct maintenance will help the mower function safely.

Do not service the mower (except for the carburetor adjustment) while the engine is running. Before you service the unit, even with the engine stopped, always disconnect the wire from the spark plug to prevent the engine from starting.

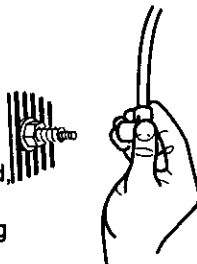

If you hit a large object during operation, stop the engine. Remove the wire from the spark plug. Carefully inspect the mower for damage. Before you start the engine again, make the necessary repairs. If you

feel new or excessive vibration, immediately stop the engine and check for the problem. Vibration can be a warning of a problem. Keep all nuts, bolts and screws tight.

The blade is the most dangerous part of the mower. Frequently check the blade and the blade mounting fasteners. Keep the fasteners tight. If the blade hits a solid object, stop the engine. Remove the wire from the spark plug. Check for a blade that is bent, cracked or for other damages. Before you start the engine, replace a damaged blade(s). For safety, replace the blade every two years.

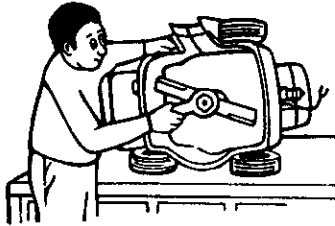

A sharp blade decreases the workload on the engine and more evenly cuts grass. Frequently sharpen the blade for a better looking cut. Use the left side of the mower housing to trim near an object.

A grass bagger is a good accessory for your mower. For best performance and safety, make sure the grass bagger is approved for use with your mower. Follow the assembly and operation instructions included with the grass bagger.

Some grass baggers require a special blade for best performance. Before you attach, check, or empty the grass bagger, always stop the engine. Before each use of the grass bagger, check for cracks, wear or deterioration. Before you use the grass bagger, replace a damaged part with a replacement part approved by the factory.



For you to have a good green lawn, follow the mowing procedures below. Do not cut the grass too short. If you cut the grass too short you can cause the grass to become yellow or make the lawn look brown. Use a lower height of cut in cool months when the grass is thicker. Raise the height of cut in hot dry periods. If you cut the grass with

a blade that is not sharp or at a slow engine speed you can damage the grass. Move the throttle control to the FAST position when mowing and using the grass bagger. Also, use a slower ground speed when using the grass bagger.

If you change the direction or pattern of cut slightly every time you mow will make the grass grow stronger and thicker. Do not add oil or gasoline to the mower while on the lawn. Spilled oil or gasoline can kill the grass. In high or thick grass, do not try to cut all the grass the first time. Raise the height of cut on the first cutting and lower the height for the next cutting. Another way is to cut only part of the width of the mower and decrease your ground speed (not the engine) to move more slowly so that the mower can discharge the grass as it moves forward.

Understand the controls and how they work. Learn the ground speed(s) of your mower. Check the stopping distance required at different travel speeds. Check the turning radius of the mower. The controls on your riding mower are different from an automobile. The throttle is operated by hand and holds the engine speed constant until it is changed. The location of the travel speed control is different from that of an automobile. Also, the brake and clutch systems are different. Remember the procedures to follow in an emergency. Remember, turning off the engine ignition switch will stop the blade and the drive mechanism. If the traction of the wheels is lost or does not feel safe, disengage all systems and stop the engine. Dismount from the mower. Push the unit to a safe place before you begin mowing again.

Your unit has an electrical system that includes an operator presence switch in the seat. The operator presence switch detects if the operator is sitting on the seat. The engine will stop if the operator leaves the seat when the blade engagement control is engaged. This operator presence switch is a safety device only. It must not regularly be used to stop the engine or the blade. There are other control systems on the mower for this purpose. Always keep the operator presence switch and other safety devices and controls in place and operating for your protection.

Remember, your mower is a tool that can be dangerous if it is not correctly used. Follow the instructions in this Instruction Book. Safe and careful use of the mower will give you many safe hours of problem free use.

STEPS TO FOLLOW

BEFORE MOWING

- Be sure to dress correctly. Wear hard shoes, not sandals or tennis shoes.
- Examine the blade. A blade that is bent, cracked, or damaged must be replaced with a factory replacement blade.
- Fill the fuel tank outside. Clean off spilled fuel.
- Read and follow the Owner's Manual, the instructions with the engine, and the instructions with any attachments. Owner's Manual instructions are for your safety and the safety of others.
- Exhaust fumes are dangerous. Start the engine outside.
- Make sure all safety devices are in place and working correctly.
- Operation of the mower is only for a person that has experience.
- Wet grass can be dangerous. Let the grass dry.
- Instruct children and others to keep away from the work area.
- Never cut the grass without good light.
- Pick up loose objects. Remove them from the mowing area.

WHILE MOWING

- Watch for fixed objects and avoid them. They can damage the mower or cause injury.
- A hot engine, muffler, and transmission will cause a burn. Do not touch.
- Inclines and slopes must be carefully mowed. See the "Guide" in the back of this book to check a slope.
- Lack of daylight or good artificial light is cause to stop mowing.
- Examine the mower, the blade, and other parts for damage after hitting a foreign object or if the unit vibrates excessively.
- Do not make adjustments or repairs without stopping the engine. Disconnect the spark plug wire.
- On or near roads, watch out for traffic. Direct discharge away from roads.
- When mowing, avoid areas where traction is unsure. Look back before changing direction of travel.
- In heavy grass, raise the cutting height. Cut slower. Stop the engine to remove clogged grass from the mower.
- Never remove any safety related parts.
- Do not pour gasoline into a engine that is hot or running.

AFTER MOWING

- Always let the mower cool before storing in an enclosed area.
- Foreign material on the mower is dangerous. Clean off grass, leaves, grease and oil before storing.
- Tighten all loose nuts, bolts and screws before you use the unit.
- Empty and clean any grass catcher or other accessory.
- Remove the key or disconnect the spark plug wire to prevent unauthorized use.
- Make sure the mower is not kept near a source of ignition. Gas fumes can cause an explosion.
- Only original parts or factory approved substitutes can be used to service the mower.
- When storing the mower for an extended period, remove the fuel from the fuel tank.
- Instruct children to leave the mower alone. It is not a toy.
- Never keep gasoline near a source of ignition. Always use an approved container. Keep gasoline away from children.
- Lubricate according to the Instruction Book. See "Lubrication".

IMPORTANT--Read the Instruction Book. Keep this book for future use and reference.



WARNING: Look for this symbol to point out important safety precautions. It means: "Attention! Become Alert! Your Safety Is Involved."

BEFORE YOU MOW

ASSEMBLY

This instruction book is for several models. Some parts or accessories are not included on all models. Read and follow the assembly and adjustment instructions for your mower. Do not discard any parts or material until the unit is assembled.



WARNING: Before doing any assembly or maintenance to the mower, remove the wire from the spark plug.

NOTE: in this instruction book, left and right describe the location of a part with the operator on the seat.

CHECK THE TIRES

Check the air pressure in the tires. Tires with too much air pressure will cause the unit to ride rough. Also, the wrong air pressure will keep the mower housing from cutting level. The correct air pressure (PSI) is 14 PSI (1 BAR). The tires were over inflated for shipment.

CHECK THE LEVEL OF THE MOWER HOUSING

Make sure the level of cut is still correct. After you mow a short distance, look at the area that was cut. If the mower housing does not cut level, see the instructions on "How To Level The Mower Housing" in the Maintenance section of this instruction book.

MAINTENANCE FREE BATTERY

IMPORTANT: Before you attach the battery cables to the battery, check the battery date. The battery date tells if the battery must be charged.

1. Check the top of the battery for the location of the battery date (Figure 1).
2. If the battery is put into service *before* the battery date, the battery cables can be attached without charging the battery. See "How To Install The Battery Cables".
3. If the battery is put into service *after* the battery date, the battery must be charged. See "How To Charge The Maintenance Free Battery".

HOW TO CHARGE THE MAINTENANCE FREE BATTERY



WARNING: When you charge the battery, do not smoke. Keep the battery away from any sparks. The fumes from the battery acid can cause an explosion.

1. Remove the battery and battery tray.
 2. Remove the protective caps from the battery terminals.
 3. Use a 12 volt battery charger to charge the battery. Charge at a rate of 6 amperes for one hour. If you do not have a battery charger, have an authorized service center charge the battery.
 4. Install the battery and battery tray. Make sure the positive (+) terminal is on the left side.
-

BEFORE YOU MOW

HOW TO INSTALL THE BATTERY CABLES



WARNING: To prevent sparks, fasten the red cable to the positive (+) terminal before you connect the black cable.

Use the fasteners shown below to install the battery cables. The fasteners are shown at full size.

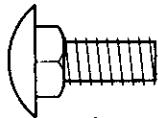

(A)
711680



(B)
711636

NOTE: For shipping purposes, the fasteners may be attached to battery terminals. Remove the fasteners before proceeding.

1. Remove the protective caps from the battery terminals.
2. Fasten the red cable to the positive (+) terminal with the fasteners as shown (Figure 1).
3. Fasten the black cable to the negative (-) terminal with the fasteners as shown.

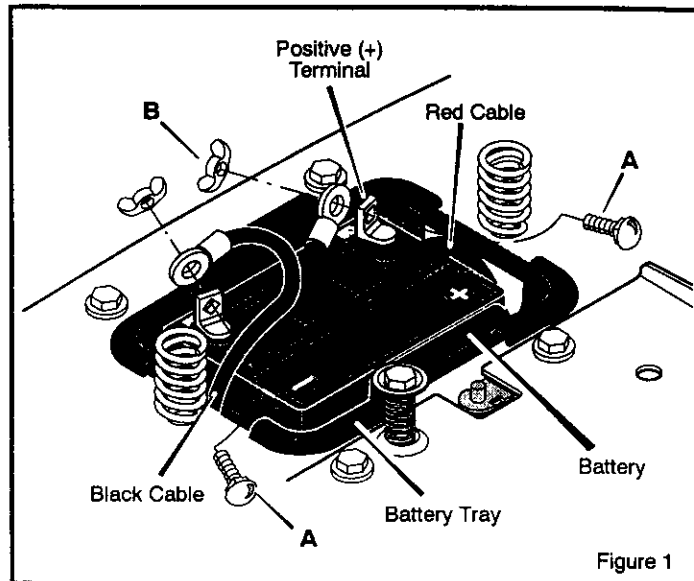

Figure 1

HOW TO PREPARE THE ENGINE

NOTE: The engine was shipped from the factory filled with oil. Check the level of the oil. Add oil as needed.

See the engine manufacturer's instructions for the type of gasoline and oil to use. Before you use the unit, read the information on safety, operation, maintenance, and storage.



WARNING: Follow the engine manufacturer's instructions for the type of gasoline and oil to use. Always use a safety gasoline container. Do not smoke when adding gasoline to the engine. When inside an enclosure, do not fill with gasoline. Before you add gasoline, stop the engine. Let the engine cool for several minutes.

IMPORTANT: This unit is equipped with an internal combustion engine and must not be used on or near any unimproved forest-covered, brush-covered or grass-covered land unless the engine's exhaust system is equipped with a spark arrester meeting applicable local or state laws (if any). If a spark arrester is used, it must be maintained in effective working order by the operator.

In the State of California the above is required by law (Section 4442 of the California Public Resources Code). Other states may have similar laws. Federal laws apply on federal lands. See an Authorized Service Center for a spark arrester for the muffler.

In some areas, local law requires the use of a resistor spark plug to control the ignition signals. See an Authorized Service Center for a resistor spark plug for the engine.

IMPORTANT! BEFORE YOU START MOWING

- Check the engine oil.
- Fill the fuel tank with gasoline.
- Check the level of the mower housing.
- Check the air pressure of the tires.
- Attach the battery cables.

OPERATION

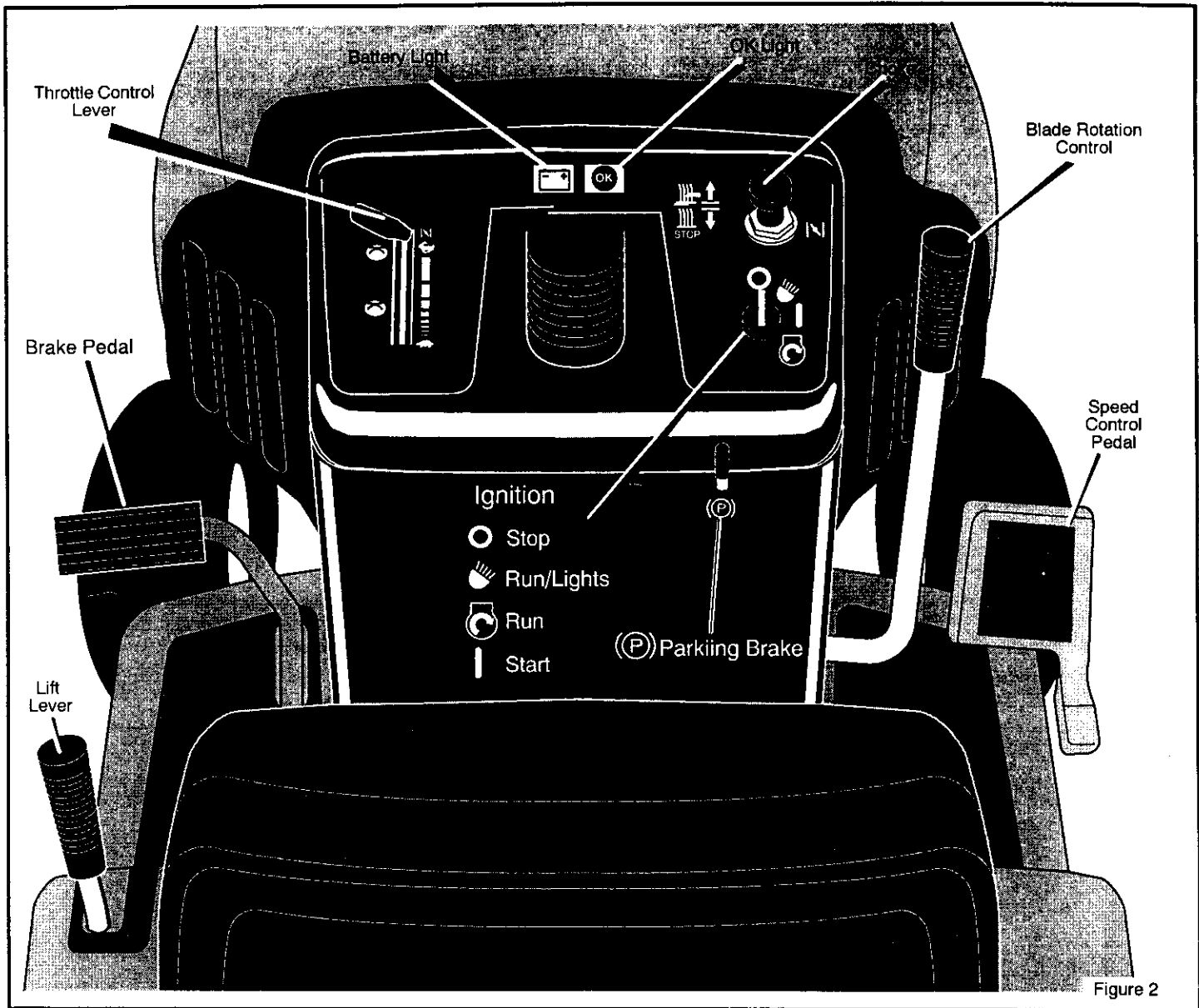

LOCATION OF CONTROLS

BLADE ROTATION CONTROL: Use the blade rotation control to start and stop the rotation of the blade.

BRAKE PEDAL: Use the brake pedal to quickly stop.

HEADLIGHT SWITCH: The headlight switch is the first part of the ignition switch. To use the lights with the engine running, turn the key to the position for the lights.

IGNITION SWITCH: Use the ignition switch to start and stop the engine.

BATTERY LIGHT: Indicates whether battery is being recharged when engine is running. When the engine is running and the light is on this means the battery **IS** charging. If indicator is not on, have a battery and/or engine charging system checked by an authorized service dealer.

OK LIGHT: If this indicator light is on, the engine will not start.

1. Your clutch-brake pedal may not be fully depressed.
2. The blade rotation control may not be in the DISENGAGE position.

AUTOMATIC DRIVE DISCONNECT: Use the automatic drive disconnect, located under the seat, to disengage the transmission.

LIFT LEVER: Use the lift lever to change the height of cut.

PARKING BRAKE LEVER: Use the parking brake lever to engage the brake when you leave the unit.

SPEED CONTROL PEDAL: Use the speed control pedal to change the speed and the direction of the unit.

THROTTLE CONTROL LEVER: Use the throttle control lever to increase or decrease the speed of the engine.

OPERATION

ATTACHMENTS

This unit can use many different attachments. See the attachment page in this book. This unit can pull attachments like a lawn sweeper, a lawn aerator, or a hopper spreader. This unit can not use attachments that engage the ground like a plow, a disk harrow, or a cultivator.

HOW TO USE THE THROTTLE CONTROL

Use the **throttle control** to increase or decrease the speed of the engine.

CAUTION: Always operate the engine with the throttle control in the **FAST** position. If the engine runs for several minutes at slower than the **FAST** position, the engine and transmission will overheat and can be damaged.

1. The **FAST** position is marked with a detent. For normal operation and when using a grass bagger, move the **throttle control** to the **FAST** position. For maximum charging of the battery and for a cooler running engine and transmission, operate the engine in the **FAST** position.
2. For transport and to tow pull behind attachments, control the ground speed with the speed control pedal.
3. The engine governor is set at the factory for maximum performance. Do not adjust the governor to increase the speed of the engine.

HOW TO USE THE BLADE ROTATION CONTROL

The **blade rotation control** is next to the steering wheel (Figure 3). Use the **blade rotation control** to engage the blade(s) or to operate a snow thrower attachment.

1. Before you start the engine, make sure the **blade rotation control** is in the **DISENGAGE** position.
2. Move the **blade rotation control** to the **ENGAGE** position to rotate the blade(s).

Note: If the engine stops when you engage the blade(s), the seat switch is not activated. Make sure you sit in the middle of the seat. Also, make sure the wire is connected to the seat switch.

3. Move the **blade rotation control** to the **DISENGAGE** position to stop the blade(s). Before you leave the operator's position, make sure the blade(s) has stopped rotating.
4. Before you ride the unit across a sidewalk or a road, move the **blade rotation control** to the **DISENGAGE** position.



WARNING: Always keep your hands and feet away from the blade, deflector opening, and the mower housing when the engine runs.

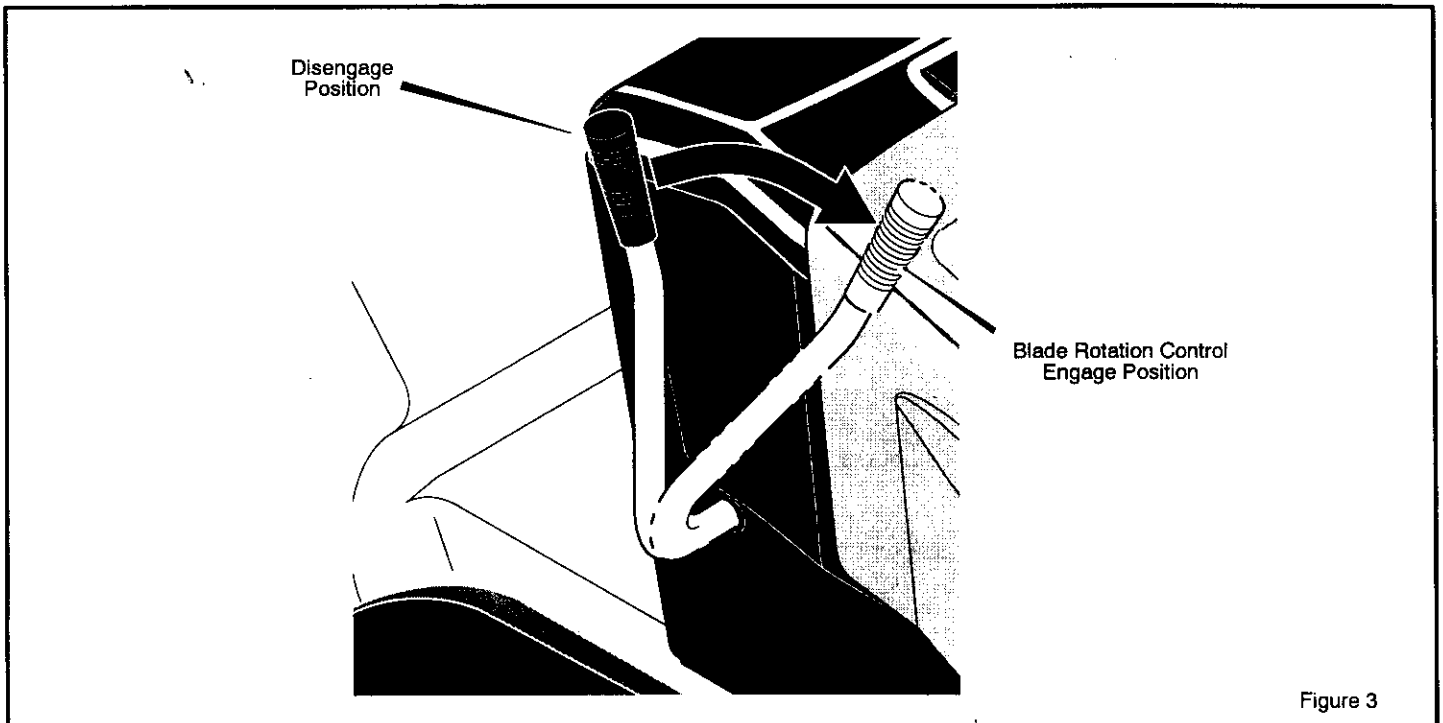

Figure 3

OPERATION

HOW TO USE THE SPEED CONTROL PEDAL

The drive system uses a Hydrostatic Automatic Drive transmission. The Hydrostatic transmission is very easy to operate. This type of drive system does not require a shift lever or a clutch pedal.

The speed and direction of travel is controlled by a single **speed control pedal** operated with your right foot. Do not use the left brake pedal in normal operation. Only use the left brake pedal to quickly stop in an emergency.

HOW TO DRIVE FORWARD

1. The **automatic drive disconnect** must be in the DRIVE position (Figure 5).
2. Slowly release your left foot from the brake pedal.
3. Move the throttle control to the FAST position.
4. Slowly push the **speed control pedal** forward to the desired speed (Figure 4).
5. To increase forward speed, slowly move the **speed control pedal** forward. To reduce forward speed, slowly release the **speed control pedal** until the unit slows to the desired speed.

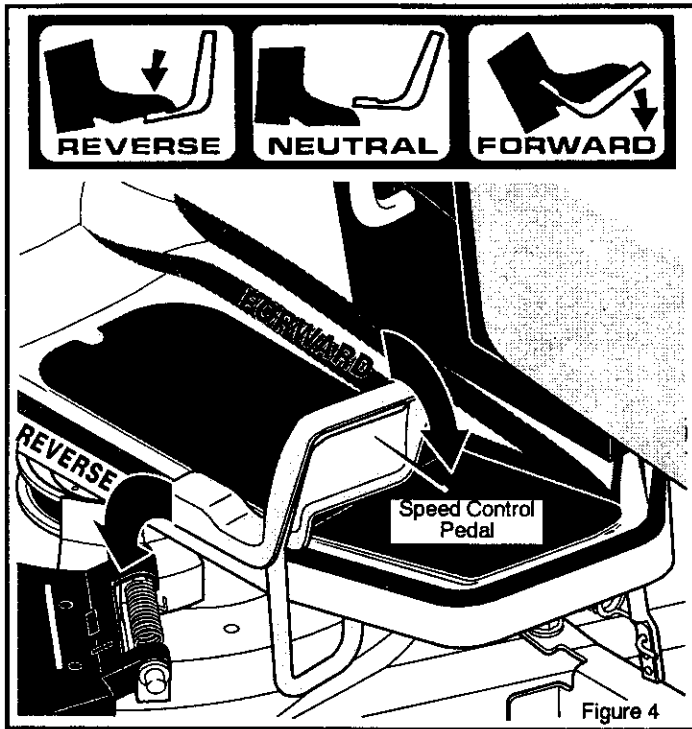

Figure 4

HOW TO DRIVE IN REVERSE

1. Look to the rear.
2. Slowly push the **speed control pedal** to the REVERSE position.

HOW TO CHANGE DIRECTIONS

CAUTION: To change directions, do not use the left brake pedal. Use only the speed control pedal.

1. Slowly remove your foot from the **speed control pedal**. The **speed control pedal** will automatically return to the NEUTRAL position.
2. When the unit stops, slowly move the **speed control pedal** to the desired direction.

SPEED CONTROL PEDAL POSITIONS

The forward speed is controlled by the position of the **speed control pedal**. The following chart provides functions along with the pedal positions. Always operate the engine with the throttle control in the FAST position.

FUNCTION	PEDAL POSITION	THROTTLE
Trimming Snow Thrower	1/3	
Bagging Grass	1/3 to 1/2	
Normal Mowing	1/2 to 2/3	
Easy Mowing Snow Blade	1/2 to 3/4	
Transport	FULL	
Pull Behind Attachments	1/3 to 1/2	

HOW TO DISCONNECT THE TRANSMISSION

To push the unit, use the **automatic drive disconnect** to release the transmission. The **automatic drive disconnect** is under the seat.

1. The engine must be off.
2. Raise the seat. The **automatic drive disconnect** is under the seat.
3. Move and latch the **automatic drive disconnect** in the PUSH position (Figure 5). The transmission is now *released* and the unit can be pushed.

NOTE: In cold weather, the heavy viscosity oil in the transmission will make the unit difficult to push.

4. To engage the transmission, unlatch the **automatic drive disconnect**. The transmission is now *connected* and ready to operate.

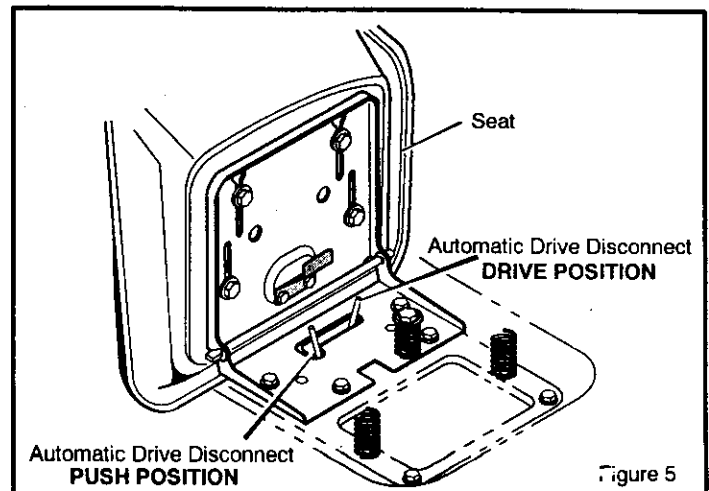

Figure 5

OPERATION

HOW TO SET THE PARKING BRAKE

1. Completely push the brake pedal forward.
2. Lift the **parking brake lever** (Figure 6).
3. Remove your foot from the brake pedal and then release the **parking brake lever**. Make sure the parking brake will hold the unit.
4. To release the parking brake, completely push the brake pedal forward. The parking brake will automatically release.



WARNING: Before you leave the operator's position, move the shift lever to the neutral (N) position. Set the parking brake. Move the blade rotation control to the DISENGAGE position. Stop the engine and remove the ignition key.

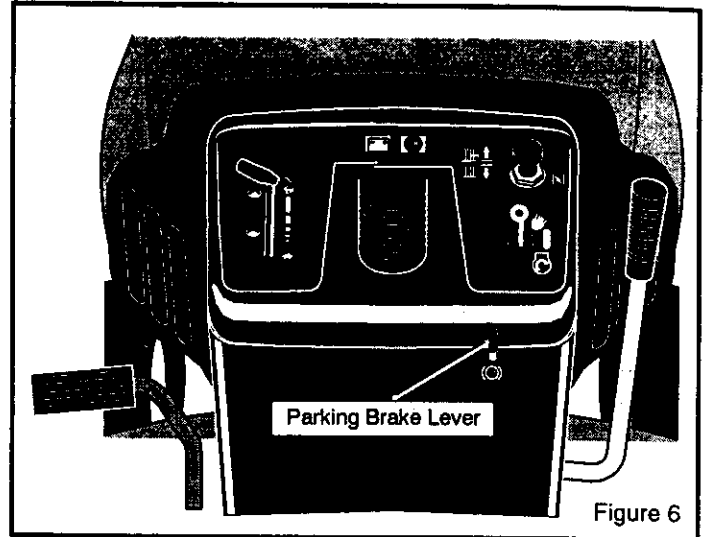

Figure 6

HOW TO CHANGE THE CUTTING HEIGHT

To change the cutting height, raise or lower the **lift lever** as follows.

1. Move the **lift lever** forward to lower the mower housing and back to raise the mower housing (Figure 7).
2. When you ride on a sidewalk or road, move the **lift lever** to the highest position and move the blade rotation control to the DISENGAGE position.

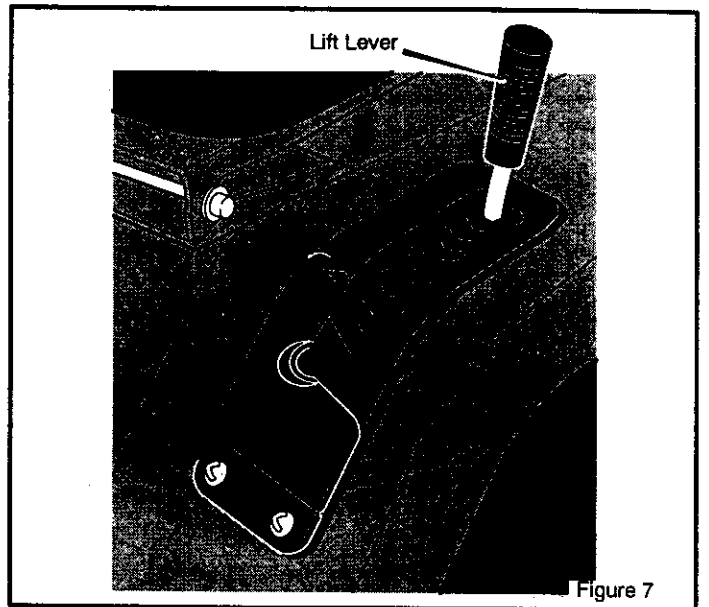

Figure 7

HOW TO STOP THE UNIT

1. Slowly remove your foot from the speed control pedal. The speed control pedal will automatically return to the NEUTRAL position and the unit will stop.
2. Move the blade rotation control to the DISENGAGE position.
3. Set the parking brake.



WARNING: Make sure the parking brake will hold the unit.

4. Move the throttle control to the SLOW position.
5. To stop the engine, turn the ignition key to the OFF position. Remove the key.

HOW TO TRANSPORT THE UNIT

To transport the unit, follow the steps below.

1. Move the blade rotation control to the DISENGAGE position
2. Raise the lift lever to the highest position.

3. Move the throttle control to the FAST position.
4. Slowly push the speed control pedal forward to the desired speed.

OPERATION

HOW TO OPERATE WITH THE MOWER HOUSING



WARNING: The deflector is a safety device. Do not remove the deflector. The deflector forces the discharged material toward the ground. Always keep the deflector in the down position. If the deflector is damaged, replace the deflector with an original equipment part from an authorized service center.

1. Start the engine.
2. Release the parking brake.
3. Move the lift lever to a height of cut position. In high or thick grass, cut the grass in the highest position first and then lower the mower housing to a lower position.

CAUTION: Do not operate with the mower housing in the LEVEL ADJUSTMENT position. If you operate in the LEVEL ADJUSTMENT position, the mower housing and blades can be damaged.

4. Move the throttle control to the SLOW position.
5. Move the blade rotation control to the ENGAGE position.
6. Move the throttle control to the FAST position.
7. Slowly push the speed control pedal to the desired speed.

NOTE: When you mow in heavy grass or mow with a grass bagger, use a slow forward speed.

8. Make sure the level of cut set at the factory is still correct. After you mow a short distance, look at the area that was cut. If the mower housing does not cut level, see the instructions on "How To Level The Mower Housing" in the Maintenance section.



WARNING: For better control of the unit, always select a safe speed.

HOW TO OPERATE THE UNIT ON HILLS



WARNING: Do not ride up or down slopes that are too steep to back straight up. Never ride the unit across a slope. See the "Slope Guide" in the back of this book for information on how to check slopes.

2. Set the parking brake.
3. Before you dismount from the seat, move the throttle control to SLOW position, move the blade rotation control to the DISENGAGED position, turn off the engine and set the parking brake.

HOW TO OPERATE ON A HILL

1. Control the speed only with the speed control pedal. Do not use the brake pedal on a hill.
2. To help prevent an accident, slowly move the speed control pedal. Avoid sudden turns or changes in speed.
3. To reduce forward speed when going down a hill, slowly release the speed control pedal until the unit slows to the desired speed.

HOW TO START OPERATION ON A HILL

1. Start the engine
2. Move the blade rotation control to the ENGAGED position.
3. Move the throttle control to the FAST position.
4. Depress the brake pedal and release the parking brake. As you release the parking brake, push the speed control pedal to the desired speed.

HOW TO STOP ON A HILL

1. Avoid stopping on a hill. If you must quickly stop in an emergency, remove your right foot from the speed control pedal and quickly depress the left brake pedal.



WARNING: Slowly push the speed control pedal as you release the parking brake. The parking brake must be disengaged before the speed control pedal is able to engage the transmission.

OPERATION

BEFORE STARTING THE ENGINE

CHECK THE OIL

NOTE: The engine was shipped from the factory filled with oil. Check the level of the oil. Add oil as needed. See the engine manufacturer's instructions for the type of gasoline and oil to use.

1. Make sure the unit is level.

NOTE: Do not check the level of the oil while the engine runs.

2. Check the oil. Follow the procedure in the engine manufacturer's instructions.
3. If necessary, add oil until the oil reaches the FULL mark on the dipstick. The quantity of oil needed from ADD to FULL is shown on the dipstick. Do not add too much oil.

ADD GASOLINE



WARNING: Always use a safety gasoline container. Do not smoke when adding gasoline to the fuel tank. Do not add gasoline when you are inside an enclosure. Before you add gasoline, stop the engine and let the engine cool for several minutes.

Fill the fuel tank with regular unleaded gasoline. Do not use premium unleaded gasoline. Make sure the gasoline is fresh and clean. Leaded gasoline will increase deposits and shorten the life of the valves.

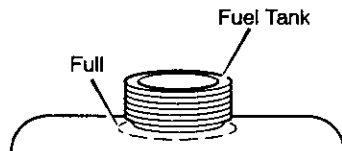

CAUTION: A mixture of alcohol (ethanol or methanol) and gasoline (called gasohol), will attract moisture and cause acid deposits during storage. While the unit is in storage, the acids in the fuel can damage the fuel system.

To prevent engine problems with the fuel system, empty the fuel system before storage of 30 days or longer as follows.

1. Drain the fuel tank.
2. Start the engine. Let the engine run until the fuel lines and the carburetor are empty.
3. After storage, make sure you use fresh fuel. See the storage instructions for additional information.
4. Never use engine cleaner or carburetor cleaner in the fuel tank or permanent damage can occur.

CARBURETOR

The factory settings for the carburetor are for most conditions. If the engine is operated under the following conditions, you can adjust the carburetor mixture. To adjust the carburetor, see the engine manufacturer's instructions.

1. The engine has a loss of power or does not run smooth.
2. A change from summer to winter operation.
3. A 40 degree change in the operation temperature. The carburetor was adjusted at 80 degrees at the factory.
4. The engine is operated above 4,000 feet.

HOW TO START THE ENGINE



WARNING: The electrical system has an operator presence system that includes a sensor switch for the seat. These components tell the electrical system if the operator is sitting on the seat. This system will stop the engine when the operator leaves the seat if the blade rotation control is engaged or if the transmission is engaged. For your protection, always make sure this system operates correctly.

NOTE: The engine will not start unless you depress the brake pedal or engage the parking brake and move the blade rotation control to the DISENGAGE position.

1. Push the brake pedal completely forward. Keep your foot on the pedal.

2. Make sure the blade rotation control is in the DISENGAGE position.
3. Move the throttle control completely forward to the CHOKE or FAST position. Some models have a separate choke knob. Pull the choke knob to the full CHOKE position.
4. Turn the ignition key to the START position. Release the key when the engine starts.

NOTE: If the engine does not start after four or five tries, see the TROUBLE SHOOTING CHART.

5. Slowly move the throttle control to the SLOW position.
6. Let a cold engine run for several minutes. Begin work when the engine is warm. To start a hot engine, move the throttle control to a position between FAST and SLOW.

OPERATION

OPERATING TIPS

1. Check the blade rotation control for correct adjustment. For the blade(s) to disengage correctly, the adjustment must be correct.
2. Before you use the unit, check the oil in the engine and add oil if necessary.
3. If the engine will not start, first make sure the wire is attached to the spark plug.
4. Make sure all the belts are inside all the belt guides. See the instructions on how to remove and install the motion drive and mower drive belts.
5. Before you make an inspection, adjustment (except for the carburetor) or repair, make sure the wire from the spark plug is disconnected.
6. For longer life of the battery on electric start models, charge the battery every three months.
7. Use the speed control pedal to change the ground speed, not the throttle control.
8. Belt noise can occur when the blade is engaged. This noise is normal and does not affect the operation of the unit.

MOWING AND BAGGING TIPS

1. For a lawn to look better, check the cutting level of the mower housing. See "How To Level The Mower Housing" in the Maintenance section.
2. For the mower housing to cut level, make sure the tires have the correct amount of air pressure.
3. Every time you use the unit, check the blade. If the blade is bent or damaged, immediately replace the blade. Also, make sure the nut for the blade is tight.
4. Keep the blade(s) sharpened. Worn blades will cause the ends of the grass to turn brown.
5. Do not cut or bag grass that is wet. Wet grass will not discharge correctly. Let the grass dry before cutting.
6. Use the left side of the mower housing to trim near an object.
7. Discharge the cut grass onto the mowed area. The result is a more even discharge of cut grass.
8. When you mow large areas, start by turning to the right so that the cut grass will discharge away from shrubs, fences, driveways, etc. After one or two rounds, mow in the opposite direction making left turns until finished (Figure 8).
9. If the grass is very high, cut two times to decrease the load on the engine. First cut with the mower housing in the highest position and then lower the mower housing for the second cut.
10. For better engine performance and an even discharge of the cut grass, always operate the engine with the throttle in FAST position.
11. When you use a bagger, operate the engine with the throttle in FAST position and the speed control pedal pushed 1/3 forward.
12. For better cutting performance and a quality cut, mow with the speed control pedal pushed 1/3 to 1/2 forward.
13. After each use, clean the bottom and top of the mower housing for better performance. Also, a clean mower housing will help prevent a fire.

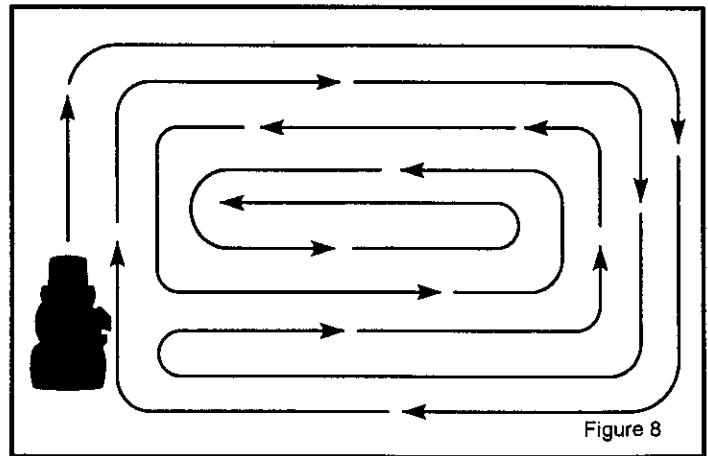

MAINTENANCE

MAINTENANCE CHART							
PROCEDURE		EACH USE	FIRST 2 HOURS	EVERY 25 HOURS	EVERY 50 HOURS	EVERY 100 HOURS	BEFORE STORAGE
M O W E R	Blade, Inspect and Sharpen			✓			
	Blade Rotation Control, Check			✓			
	Brake, Check			✓			
	Motion Drive Belt, Check			✓			
	Tires, Check			✓			✓
	Battery, Check and Charge			✓			✓
	Battery, Clean					✓	✓
	Lubrication					✓	✓
	Hydrostatic Cooling Fan and Fins, Check					✓	✓

GENERAL RECOMMENDATIONS

1. The owner's responsibility is to maintain this product. This will extend the life of the product and is also necessary to maintain warranty coverage.
2. Check the spark plug, drive brake, lubricate the unit, and clean the air filter once a year.
3. Check the fasteners. Make sure all fasteners are tight.
4. Follow the Maintenance section to keep the unit in good operating condition.



WARNING: Before you make an inspection, adjustment, or repair to the unit, disconnect the wire to the spark plug. Remove the wire from the spark plug to prevent the engine from starting by accident.

NOTE: Torque is measured in foot pounds (metric Nm). This measurement describes how tight a nut or bolt must be. The torque is measured with a torque wrench.

HOW TO CHECK THE MUFFLER

Check the muffler every 50 hours. Make sure the muffler is correctly mounted and is not loose. If the muffler is worn or burnt, replace with a new muffler. A worn muffler is a fire hazard and can also damage the engine.

If you mount a spark arrester to the muffler, also check the spark arrester when you check the muffler. If the spark arrester is worn or damaged, replace it with a new spark arrester. See your nearest authorized service center for a spark arrester.

MAINTENANCE

INSPECT BLADE



WARNING: Before you inspect or remove the blade, disconnect the wire to the spark plug. If the blade hits an object, stop the engine. Check the unit for damage. The blade has sharp edges. When you hold the blade, use gloves or cloth material to protect your hands.

If you keep the blade sharp and inspect the blade for damage, the blade will cut better and be more safe to operate. Frequently check the blade for excessive wear, cracks, or other damage. Frequently check the nut that holds the blade. Keep the nut tight. If the blade hits an object, stop the engine. Disconnect the wire to the spark plug. See if the blade is bent or damaged. Check the blade adapter for damage. Before you operate the unit, replace damaged parts with original equipment parts. See the authorized service center in your area. Every three years, have an authorized service person inspect the blade or replace the old blade with an original equipment part.

HOW TO REMOVE AND INSTALL THE BLADE

1. Remove the mower housing. See the instructions on "How To Remove The Mower Housing".
2. Use a piece of wood to keep the blade from rotating.
3. Remove the nut that holds the blade (Figure 9).

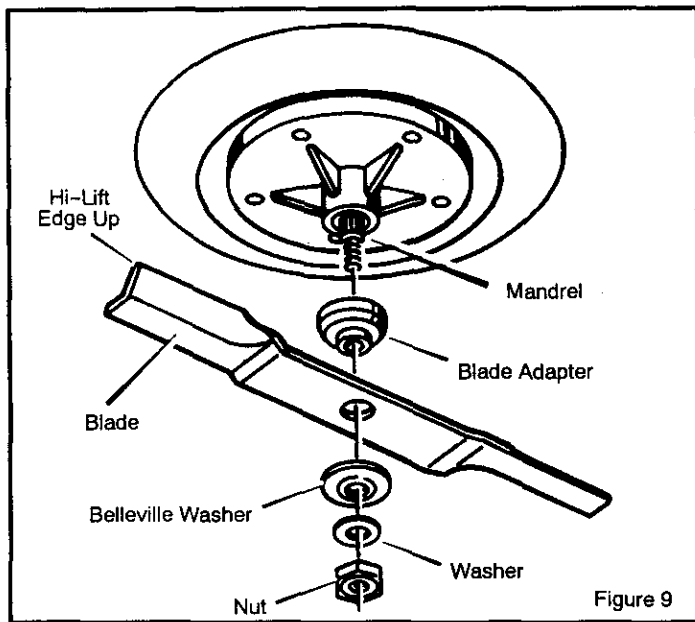

4. Check the blade and the blade adapter according to the instructions for "Inspect Blade". Replace a badly worn or damaged blade with an original equipment blade. See an authorized service center in your area.
5. Clean the top and bottom of the mower housing. Remove all the grass and debris.
6. Mount the blade and blade adapter on the mandrel (Figure 9).
7. Mount the blade so that the hi-lift edges are up. If the blade is upside down, the blade will not cut correctly and can cause an accident.
8. Fasten the blade with the original washers and nut. Make sure the outside rim of the Belleville washer is against the blade (Figure 10).



WARNING: Always keep the nut tight that holds the blade. A loose nut or blade can cause an accident.

9. Tighten the nut that holds the blade to a torque of 35 foot pounds (47,5 N-m).
10. Install the mower housing. See "How To Install The Mower Housing".

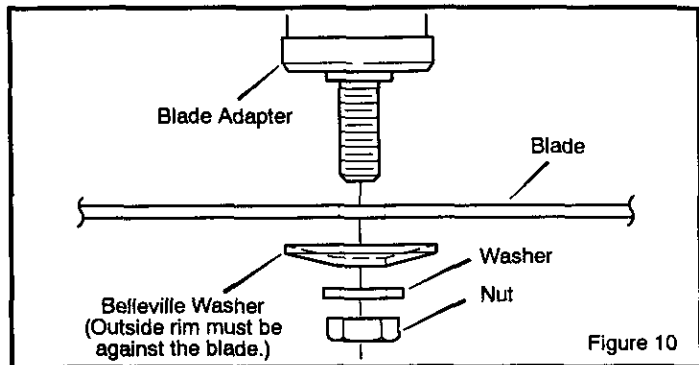

HOW TO SHARPEN THE BLADE



WARNING: Vibration can be caused if the blade is not correctly balanced or if the blade is damaged. A blade that is damaged with cracks can break and cause an accident.

Keep a sharp edge on the blade. A blade that is not sharp will cause the tips of the grass to become brown.

1. Sharpen the blade two times a year or every 25 hours.
2. Remove the blade according to the instructions in "How To Remove And Install The Blade".
3. Clean the blade with a brush, soap and water. Check the blade. Look for cracks, nicks, or other damage. Replace a badly worn or damaged blade with an original equipment blade. See an authorized service center in your area.
4. Sharpen the blade with a file (Figure 11). Make sure you keep the original bevel angle.
5. Make sure the blade is balanced. Use a screwdriver and hold the blade parallel to the ground (Figure 11). A blade that is balanced will stay parallel to the ground. If the blade is not balanced, the heavy end will rotate toward the ground. Sharpen the heavy end until the blade is balanced.
6. A new blade will cut better than a badly worn blade. Every three years, have an authorized service person inspect the blade or replace the old blade with an original equipment blade.
7. Assemble the blade according to the instructions "How To Remove And Install The Blade".

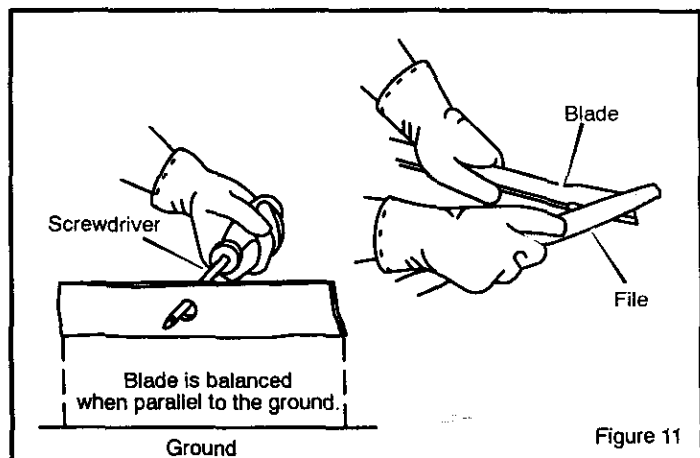

MAINTENANCE

HOW TO ADJUST THE BLADE ROTATION CONTROL



WARNING: To prevent an injury, the blade rotation control must operate correctly.

In normal usage, the **blade rotation control** will not require an adjustment. However, if the cutting performance decreases or the quality of cut is poor, make the following changes.

1. When you mow, make sure the throttle control is in the **FAST** position.
2. Move the **blade rotation control** to the **DISENGAGE** position (Figure 12).
3. Stop the engine. Disconnect the wire from the spark plug.

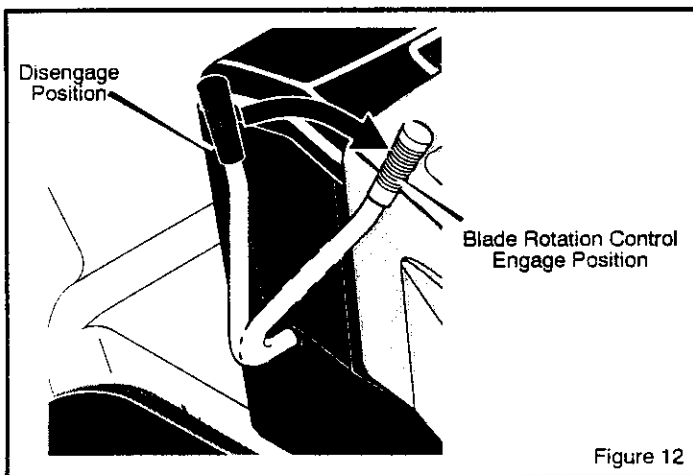

Figure 12

4. Check the blade(s). Keep a sharp edge on the blade(s). A blade that is not sharp will cause the tips of the grass to become brown.
5. Disconnect the **blade drive spring** from the **blade control rod**. Move the **blade drive spring** to the *middle hole* (Figure 13). This will increase the tension on the **mower drive belt**.

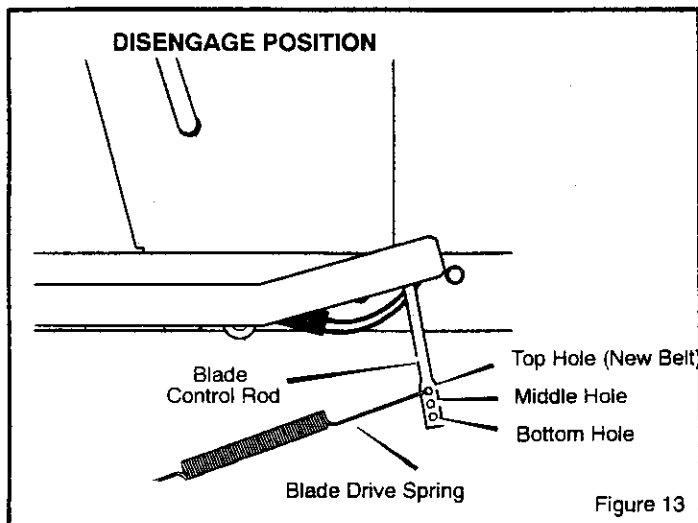

Figure 13

6. Attach the wire to the spark plug. Mow for a short distance and again check the quality of cut. If necessary, move the **blade drive spring** to the *bottom hole*.
7. Again check the quality of cut. If the quality of cut has not improved, replace the **mower drive belt**. See "How To Replace The Mower Drive Belt". If replacing the belt does not correct the problem, take the unit to an authorized service center.
8. Move the **blade rotation control** to the **DISENGAGE** position. Stop the engine. Disconnect the wire from the spark plug. Check the operation of the **blade brake**. Rotate the pulleys with your hand. Make sure the **brake pads** are pressed tightly against the pulleys (Figure 14).



WARNING: If the brake pads do not press tightly against the pulleys, take the unit to an authorized service center.

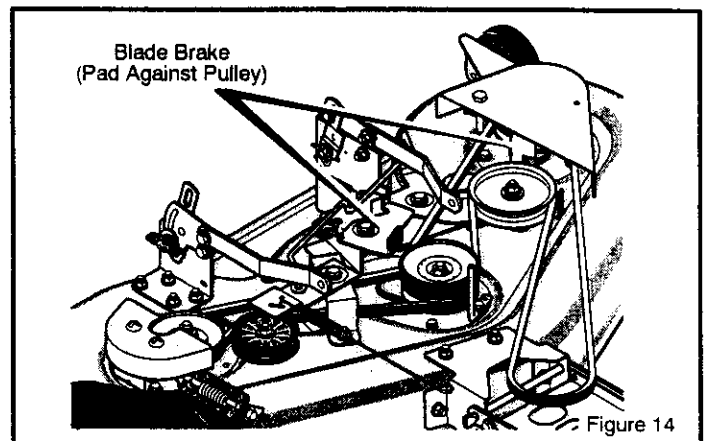

Figure 14

9. Move the **blade rotation control** to the **ENGAGE** position. Check the pads for the **blade brake**. If the pads are excessively worn or damaged, replace the **brake pad assemblies**. Correct replacement parts and assistance are available from an authorized service center.
10. Attach the wire to the spark plug. Mow for a short distance and again check the operation of the **blade rotation control**.
11. When you move the **blade rotation control** to the **DISENGAGE** position, all movement will stop within five seconds. If there is movement of the belt or the blades continue to rotate, engage and disengage the **blade rotation control** five times to remove any excess rubber from a new **mower drive belt**. If you need assistance, take the unit to an authorized service center.
12. If you replace the **mower drive belt**, move the **blade drive spring** to the *top hole* (Figure 13).

MAINTENANCE

HOW TO CHECK AND ADJUST THE DRIVE BRAKE

Completely push the brake pedal forward. Set the parking brake. Move the automatic drive disconnect to the PUSH position. Push the unit. If the rear wheels rotate, adjust or replace the brake pads. Adjust the **drive brake** as follows.

1. The location of the **drive brake** is on the right side of the **gearbox** (Figure 15).
2. Make sure the parking brake is set and the automatic drive disconnect is in the PUSH position. Turn the **hex nut** in a clockwise direction until the rear wheels do not turn when the unit is pushed forward.
3. Release the parking brake and push the unit. If the unit does not roll, turn the **hex nut** in a counterclockwise direction until the unit rolls.
4. Set the parking brake. Push the unit. If the rear wheels do not turn, the **drive brake** is correctly adjusted. Release the parking brake.

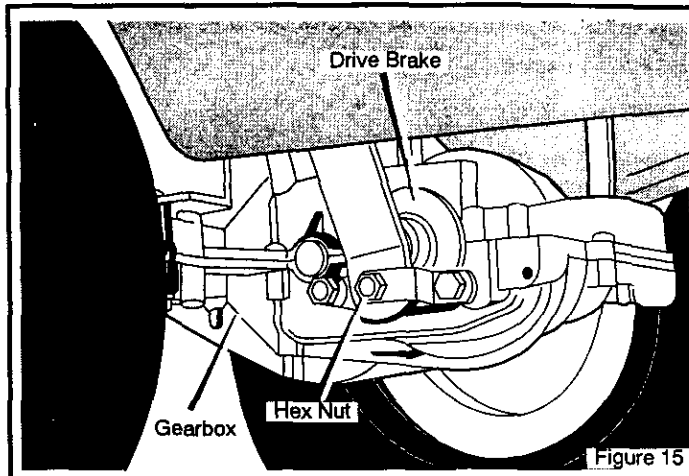

WARNING: If you cannot correctly adjust the drive brake, replace the brake pads. Correct replacement parts and assistance are available from an authorized service center.

HOW TO CHECK AND ADJUST THE MOTION DRIVE BELT

If the motion drive belt is loose, the belt will slip when; (1) going up a hill, (2) pulling a heavy load, or (3) the unit will not move forward. Adjust the belt as follows.



WARNING: Before you make an inspection, adjustment, or repair to the unit, disconnect the wire to the spark plug. Remove the wire from the spark plug to prevent the engine from starting by accident.

1. Check the routing of the motion drive belt. Make sure the belt is installed correctly and is inside all the belt guides.
2. Remove the **cotter pin**, **washer**, and **brake spring** from the **adjustable nut** (Figure 16).
3. Disconnect the **adjustable nut** from the **brake lever assembly** and the **parking brake latch**.
4. Use the **cotter pin** removed in step 2. Hold the **cotter pin** at the back of the slot and move the **brake lever assembly** rearward against the **cotter pin**. This will set a **1/8 inch (3 mm)** gap between the **brake lever assembly** and the back of the slot (Figure 16).
5. Turn the **adjustable nut** until the nut will fit through the hole in the **brake lever**.
6. Assemble the **adjustable nut** to the **parking brake latch**, **brake lever** and **brake spring**. Fasten with the **washer** and **cotter pin**.

7. If the belt still slips after the belt has been adjusted, then the motion drive belt is worn or damaged and must be replaced. See "How To Replace The Motion Drive Belt".

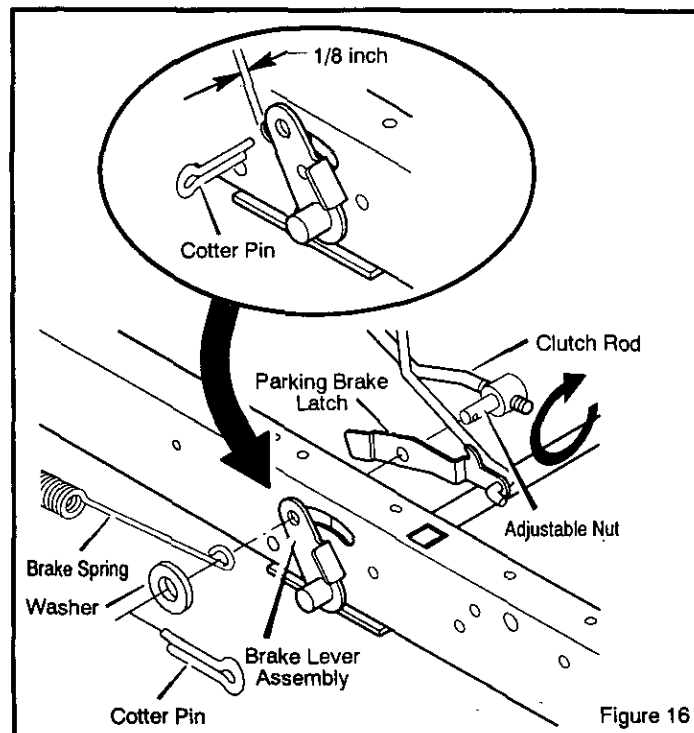

MAINTENANCE

HOW TO ADJUST THE SPEED CONTROL PEDAL

If the unit will not go into REVERSE or if the unit moves very slowly in REVERSE, adjust the speed control pedal as follows.

1. Stop the engine.
2. Set the parking brake.
3. Remove the hair pin from the adjuster nut (Figure 17). Disconnect the adjuster nut from the yoke assembly.
4. Rotate the adjuster nut *one turn* in the direction shown in Figure 17.

NOTE: Too much adjustment will cause REVERSE speed to be too fast and the FORWARD speed to be reduced.

5. Attach the adjuster nut to the yoke assembly with the hair pin.
6. To check the adjustment, drive the unit. If the adjustment is correct, the unit will now go into REVERSE.

IMPORTANT: If you need assistance, go to the nearest Authorized Service Center. They have the equipment and experience to make the adjustment.

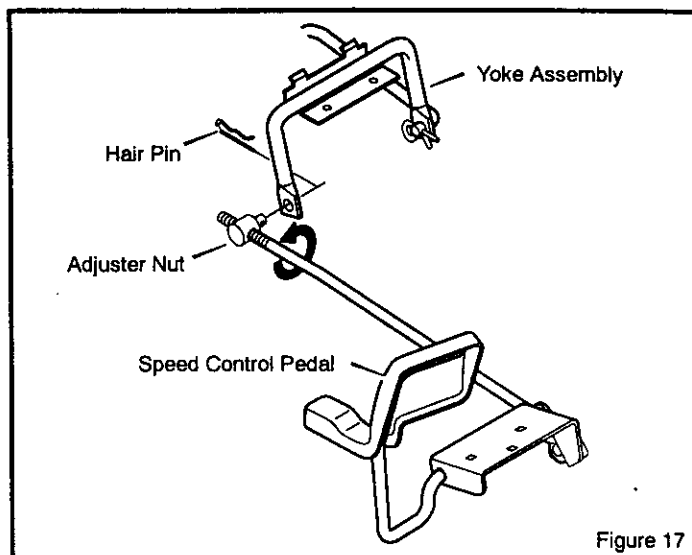

MAINTENANCE FREE BATTERY

HOW TO REMOVE THE BATTERY

To charge or clean the battery, remove the battery from the unit as follows.



WARNING: To prevent sparks, disconnect the black battery cable from the negative (-) terminal before you disconnect the red cable.

WARNING: The battery contains sulfuric acid which is harmful to the skin, eyes and clothing. If the acid gets on the body or clothing, wash with water.

1. Disconnect the black cable from the negative (-) terminal (Figure 18).
2. Disconnect the red cable from the positive (+) terminal.
3. Lift the battery tray and the battery out of the unit.

HOW TO CLEAN THE BATTERY

1. Remove the battery.
2. Wash the battery with a solution of one gallon of water and four tablespoons of baking soda (sodium bicarbonate). Make sure the solution does not get into the battery cells.
3. Clean the terminals and the ends of the cables with a wire brush.
4. Install the battery.
5. To prevent corrosion, apply grease to the battery terminals.

HOW TO CHARGE THE BATTERY



WARNING: When you charge the battery, do not smoke. Keep the battery away from any sparks. The fumes from the battery acid can cause an explosion.

1. Before you charge the battery, remove the battery.
2. To charge the battery, use a 12 volt battery charger. Charge at a rate of 6 amperes for 1 hour.
3. Install the battery.



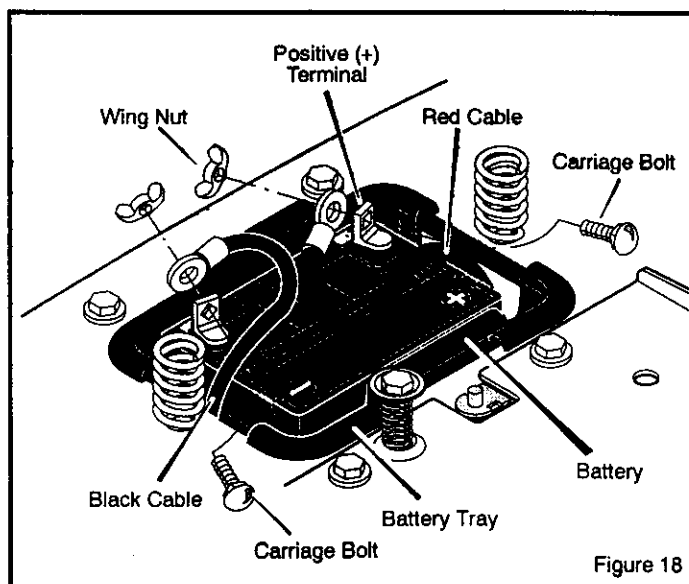

WARNING: To prevent sparks, fasten the red cable to the positive (+) terminal before you connect the black cable.

4. Fasten the red cable to the positive (+) terminal with the fasteners as shown.
5. Fasten the black cable to the negative (-) terminal with the fasteners as shown.



MAINTENANCE

WHERE TO LUBRICATE

-  Models with grease fittings: Lubricate with grease gun.
-  Apply grease with a brush to the areas shown.
-  Lubricate the areas shown with engine oil.

NOTE: Apply grease to the steering gear assembly.
CAUTION: If the unit is operated in dry areas that have sand, use a dry graphite spray to lubricate the unit.

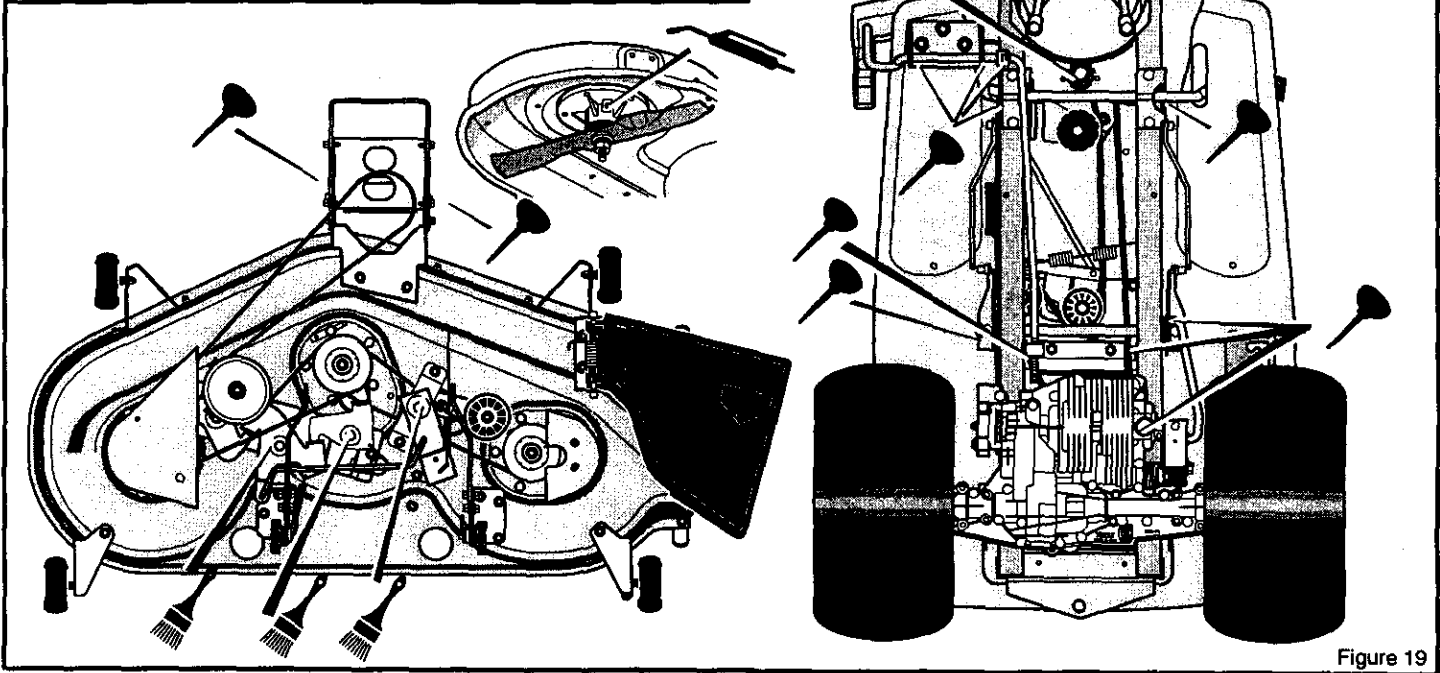

Figure 19

HOW TO OPERATE THE QUICK RELEASE OIL DRAIN VALVE

Before changing the oil, refer to the Engine Owner's Manual for the recommended type oil and the correct procedure.

To operate the quick release oil drain valve, proceed as follows.

1. Loosen the oil fill cap to serve as an air vent.
2. Turn **oil drain valve** counter-clockwise and pull to release the **oil drain valve**. See Figure 20.
3. Open the **oil drain cap**.

NOTE: To make the job cleaner, use an optional hose to drain the oil.

4. After draining the oil, close the **oil drain cap**.
5. To lock the **oil drain valve**, push and turn the **oil drain valve** clockwise.

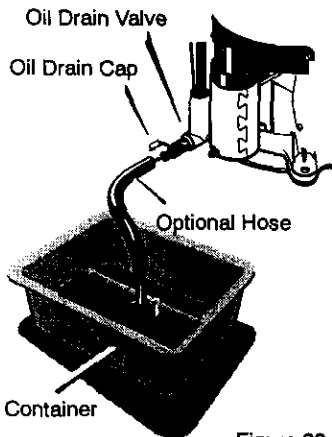

Figure 20

HOW TO CHECK THE FUEL FILTER

NOTE: Before you replace the fuel filter or the fuel line, the fuel tank must be empty.

If the **fuel filter** is dirty, the engine will run rough and have less performance. Remove the old filter (NO TAG). Replace the old filter with a new filter. Use an original equipment part. See an authorized service dealer in your area.

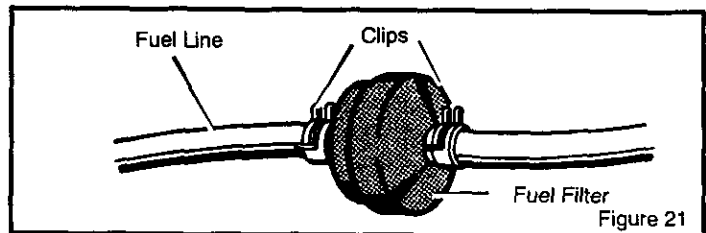

Figure 21

CHECK THE TIRES

The tires were over inflated for shipment. Check the air pressure in the tires. Tires with too much air pressure will cause the unit to ride rough. Also, the wrong air pressure will keep the mower housing from cutting level. Recommended tire pressure is 10 to 14 PSI. Check side wall of tires for manufacturer's maximum tire pressure. **DO NOT** exceed this pressure.

MAINTENANCE

HOW TO REMOVE THE MOWER HOUSING

1. Move the **blade rotation control** to the **DISENGAGE** position.
2. If equipped, remove the gauge wheels.
3. Move the **lift lever** to the level adjustment position (Figure 22).



WARNING: The lift lever is spring loaded. Make sure the lift lever is locked in the LEVEL ADJUSTMENT position.



4. Remove the hair pins and the washers from the **adjuster arms** (Figure 23). See illustrations "C" and "D".
5. Remove the hair pins and washers from the **suspension links**. See illustrations "A" and "B".
6. Disconnect the **extension spring** from the **blade control rod**. See illustration "E".
7. Disconnect the **front hanger** from the axle support. See illustration "F".
8. Remove the **mower drive belt** from the **stack pulley**.
9. Pull the mower housing away from the right side of the unit.
10. To operate without the mower housing, move the lift lever to the **TOP** position.

HOW TO INSTALL THE MOWER HOUSING

1. Push the mower housing under the right side of the unit.
2. Put the **mower drive belt** around the **stack pulley**. Make sure the "V" side of the **mower drive belt** is against the **stack pulley**. Also, make sure the **mower drive belt** is not twisted.
3. Attach the **front hanger** to the axle support with the **hanger rod**. Fasten with the fasteners as shown. See illustration "F".
4. Make sure the **mower drive belt** is between the **stack pulley** and the two **belt guides**. See illustration "G".
5. Attach the **suspension links** to the **lifter assembly**. Fasten with the washers and hair pins. See illustrations "A" and "B".
6. Attach the right and the left **adjuster arms** to the suspension brackets. Fasten with the washers and hair pins. See illustrations "C" and "D".
7. Attach the **extension spring** to the **blade control rod**. See illustration "E".
8. Move the **blade rotation control** to the **ENGAGE** position. Make sure the **mower drive belt** is inside all the **belt guides**.
9. Make sure the mower housing is level. See the instructions on "How To Level The Mower Housing".
10. If equipped, install the gauge wheels.
11. Check the operation of the **blade rotation control**. See the instructions on "How To Adjust The Blade Rotation Control".

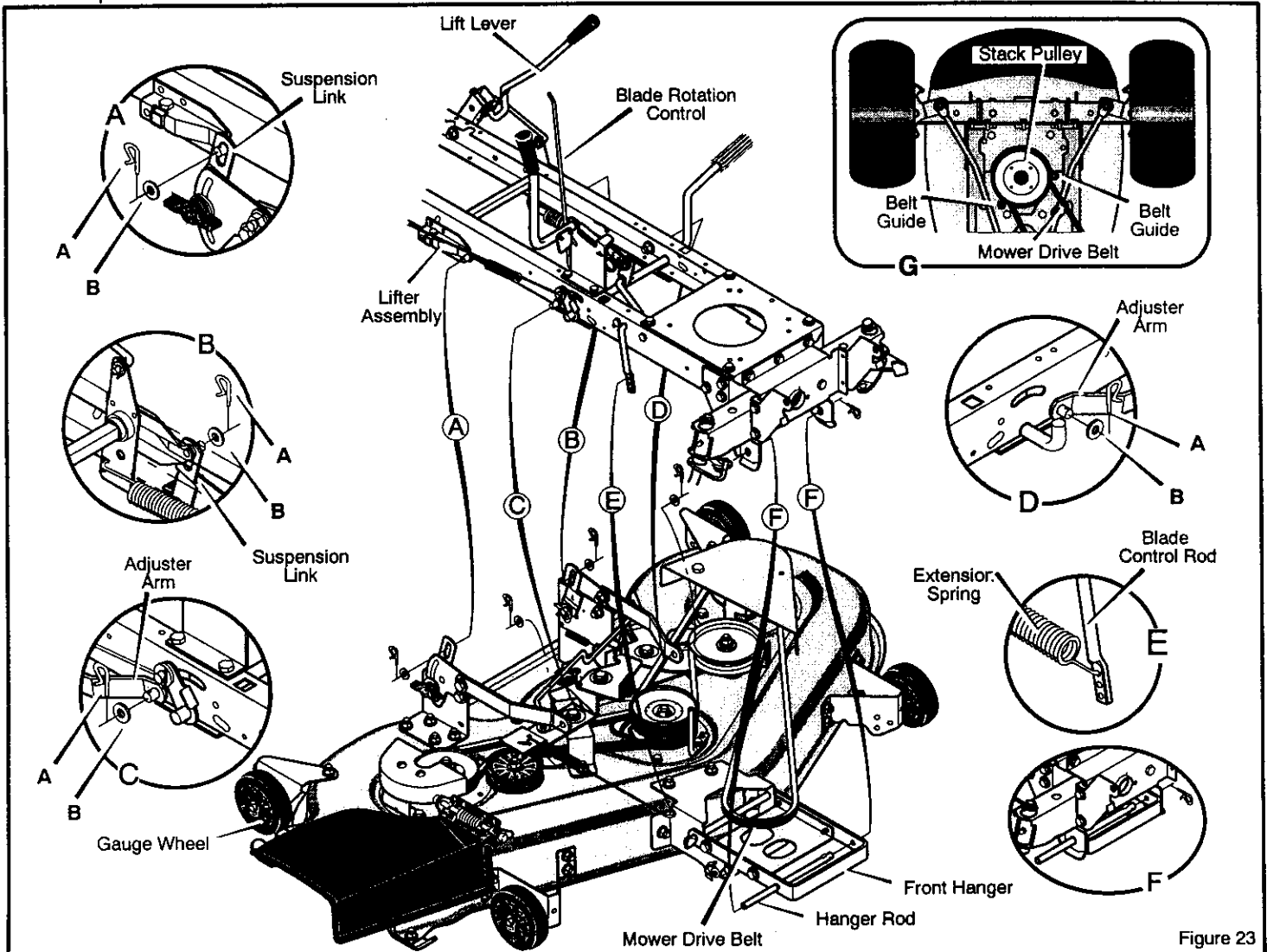

Figure 23

MAINTENANCE

HOW TO ADJUST THE GAUGE WHEELS

The axle bolts for the gauge wheels were mounted in the LOW cut position. To change the position of the gauge wheels, move the axle bolts as follows.

IMPORTANT: Before you adjust the gauge wheels, you must do the following. Make sure the mower housing is level. Make sure the height of cut is set at the height you want for your lawn. Mow a short distance on a flat level area and look at the area that was cut. If the mower housing does not cut level, see the instructions "How To Level The Mower Housing."



WARNING: Before you make an inspection, adjustment, or repair to the unit, disconnect the wire to the spark plug. Remove the spark plug wire to prevent the engine from starting by accident.

1. Remove the **gauge wheels** (Figure 24).
2. Mow a short distance on a flat level area to check the level of cut and the height of cut. Look at the **height of cut position number** on the **lift lever** (Figure 25).
3. Look at each **gauge wheel bracket**. There are 3 holes in each bracket and a number next to each hole. The number for the height of cut position on the **lift lever** indicates the correct hole to use on each **gauge wheel bracket** (Figure 26).
4. Assemble the axle bolts to the **gauge wheel brackets** using the correct hole in the bracket as indicated (Figure 26).

NOTE: If the height of cut position is changed by the lift lever, you must move the gauge wheels to the correct hole (Figure 26) to keep a level height of cut.

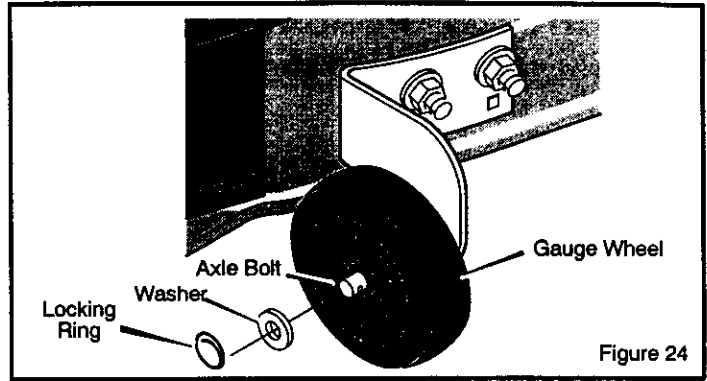

Figure 24

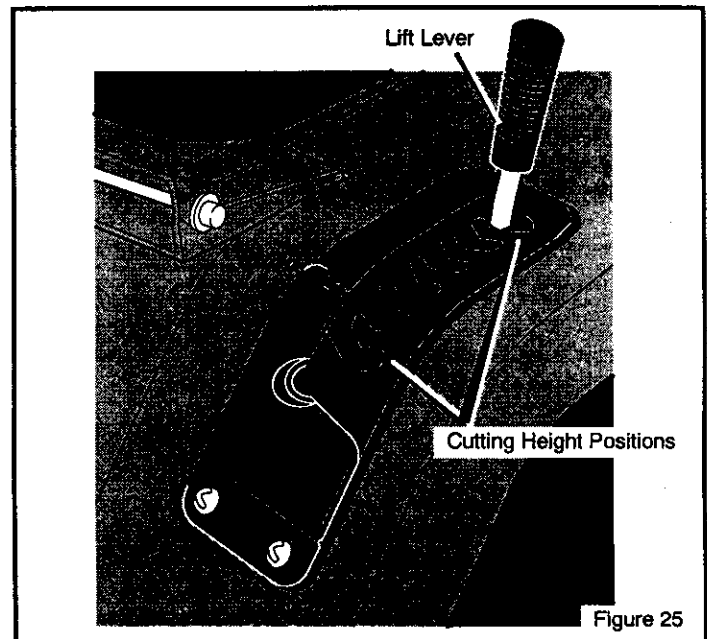
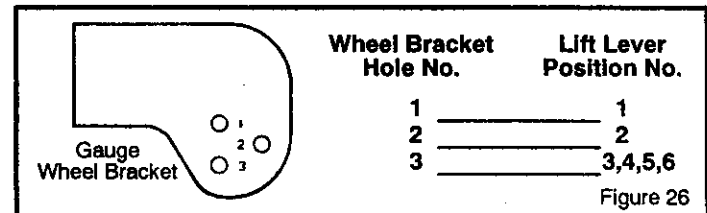

Figure 25



MAINTENANCE

HOW TO LEVEL THE MOWER HOUSING

If the mower housing is level, the blade will cut easier and the lawn will look better.



WARNING: Before you make an inspection, adjustment, or repair to the unit, disconnect the wire to the spark plug. Remove the spark plug wire to prevent the engine from starting by accident.

1. Make sure the unit is on a hard flat surface.
2. Check the air pressure in the tires. If the air pressure is incorrect, the mower housing will not cut level. Make sure the tires are inflated to 14 PSI. (1 BAR).

IMPORTANT: On models equipped with gauge wheels, the gauge wheels must be removed to correctly adjust the level of the mower housing.

3. Some models have gauge wheels on the mower housing. If equipped, remove the gauge wheels.
4. Open the cover.
5. Move the lift lever to the LEVEL ADJUSTMENT position (Figure 27).



WARNING: The lift lever is spring loaded. Make sure the lift lever is locked in the LEVEL ADJUSTMENT position.

6. Loosen the left and right **adjuster knobs** (Figure 28). Push down on each side of the mower housing. Make sure both sides of the mower housing are setting on a flat surface. Also, make sure the lift links are loose and can easily move up or down.
7. Push down on the **lift links** and tighten the left and right **adjuster knobs** (Figure 28). Make sure the **adjuster knobs** are tight. If necessary, use a wrench to tighten the **adjuster knobs**.
8. Raise the **lift lever** from the LEVEL ADJUSTMENT position to a CUTTING HEIGHT position (Figure 29).
9. Close the **cover**.
10. If equipped, install the gauge wheels.
11. Mow for a short distance. If the height of cut is not level, repeat the above steps.

CAUTION: Do not operate with the mower housing in the LEVEL ADJUSTMENT position. If you operate in the LEVEL ADJUSTMENT position, the mower housing and blades can be damaged.

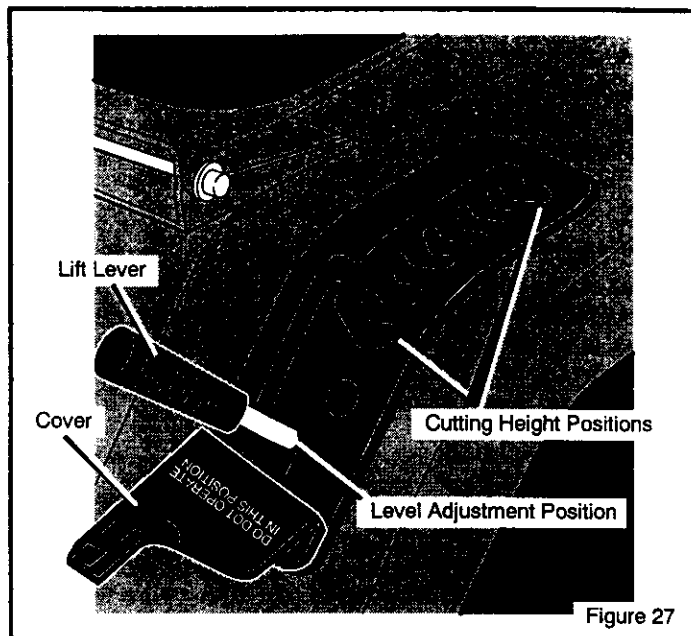

Figure 27

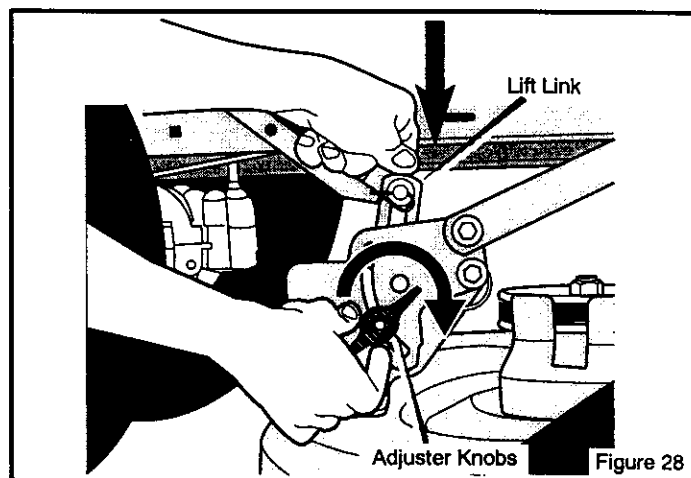

Figure 28

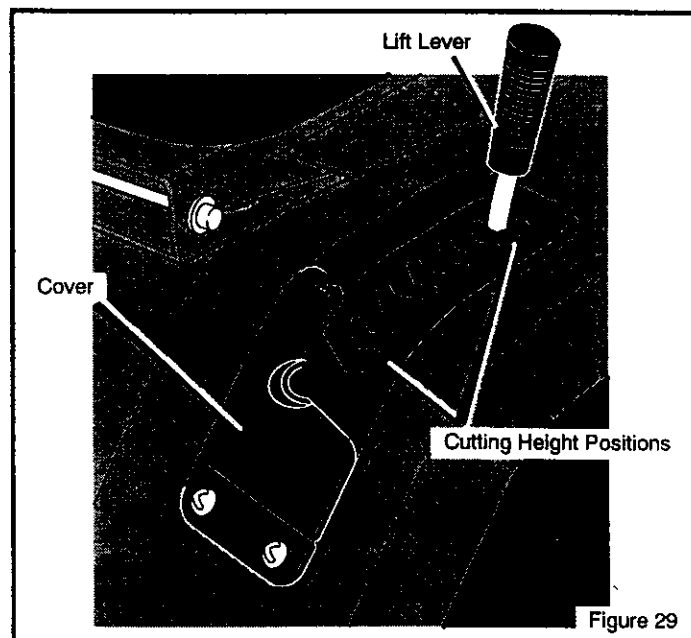

Figure 29

MAINTENANCE

HOW TO REPLACE THE MOTION DRIVE BELT

REMOVAL

1. Remove the mower housing. See the instructions on "How To Remove The Mower Housing".
2. Completely push the pedal forward and engage the parking brake.
3. Loosen the **belt guide** at the **idler pulley**. Move the **belt guide** away from the **idler pulley** (Figure 30).
4. Remove the **idler pulley** (Figure 30).
5. Disengage the parking brake.
6. Remove the **V-Idler pulley**.
7. Remove the **belt guide** at the **middle idler pulley**.
8. Remove the **motion drive belt** from the **drive pulley**.
9. To remove the **motion drive belt** from the **stack pulley**, pull the front end of the belt under the **stack pulley** and then back between the stack pulley and the **steering plate** (Figure 31).
10. Remove the **motion drive belt**. A correct replacement part or assistance is available from an Authorized Service Center in your area.

INSTALLATION

1. Slide the **motion drive belt** between the **stack pulley** and the **belt guides** (Figure 31). Install the **motion drive belt** on the top pulley of the **stack pulley**. Make sure the "V" side of the belt is against the pulley.
2. Push the **motion drive belt** through the opening between the **steering plate** and the engine plate. Make sure the **motion drive belt** is on the left side of the steering shaft assembly.
3. Install the end of the **motion drive belt** around the **drive pulley** (Figure 30).
4. Put the **motion drive belt** around the **V-Idler pulley**. Install the **motion drive belt** and **V-Idler pulley**.
5. Completely push the pedal forward and engage the parking brake.
6. Put the belt around the **idler pulley**. Assemble the **idler pulley**. Fasten the **idler pulley** with the hex nut. Make sure the flat side of the belt is against the **idler pulley**. Also, make sure the belt is not twisted.

7. Move the **belt guide** under the edge of the **idler pulley** (Figure 32). Tighten the **belt guide**.
8. Disengage the parking brake.
9. Install the **belt guide** at the **middle idler pulley**. Make sure the back of the **motion drive belt** is against **middle idler pulley**.
10. Check the routing of the motion drive belt (Figure 32). Make sure the **motion drive belt** is installed correctly on the **idler pulleys** and inside all **belt guides**.
11. Before you use the unit, check the adjustment of the clutch. See the instructions "How To Check And Adjust The Clutch".
12. Install the mower housing. See the instructions "How To Install The Mower Housing".

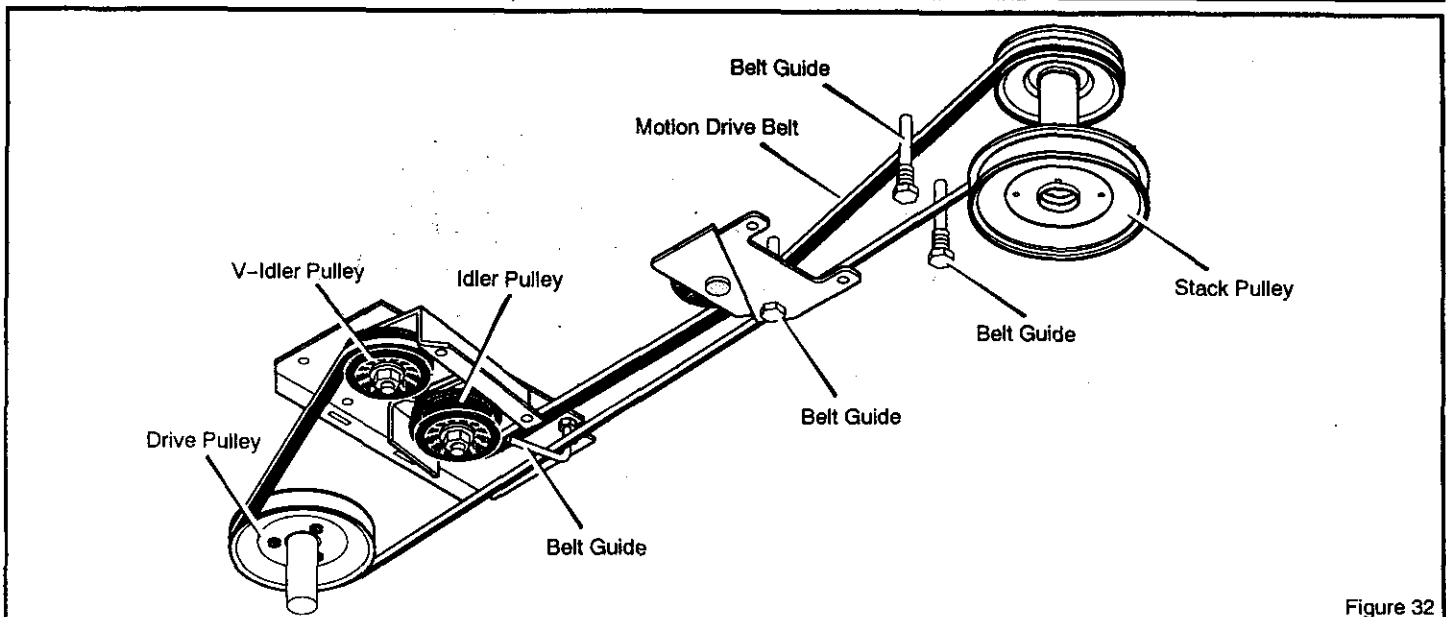
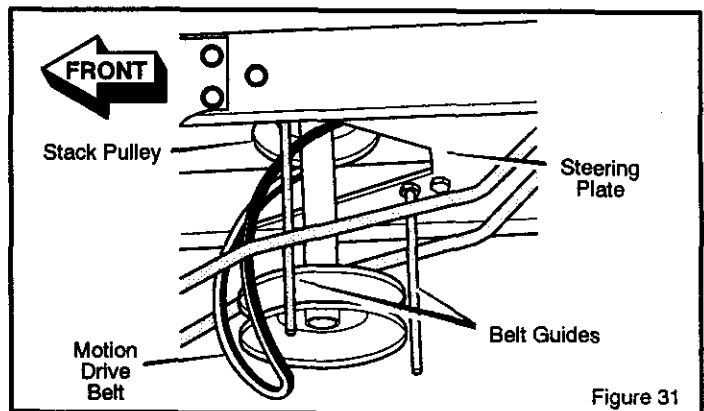
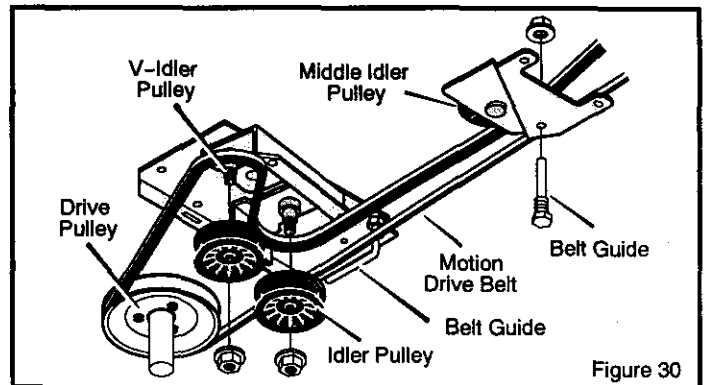

MAINTENANCE

HOW TO REPLACE THE PRIMARY MOWER DRIVE BELT

1. Remove the mower housing. See the instructions on "How To Remove The Mower Housing".
2. Remove the three screws from the left pulley cover. Remove the pulley cover.
3. Pull the belt retainer away from the idler pulley. Remove the primary mower drive belt from the idler pulley.
4. Move the brake pad assembly away from the stack pulley. Remove the primary mower drive belt from the stack pulley.

NOTE: Replace the primary mower drive belt with an original equipment belt. See an authorized service center in your area.

5. Install a new primary mower drive belt. Pull the brake pad assembly away from the stack pulley. Put the belt around the stack pulley. Make sure the primary mower drive belt is inside of the belt guide.
6. Pull the belt retainer away from the idler pulley. Put the flat side of the primary mower drive belt around the idler pulley.
7. Make sure the "V" side of the primary mower drive belt is against the mandrel pulleys as shown.
8. Make sure the primary mower drive belt is inside all the belt guides.
9. Assemble the left pulley cover.
10. Install the mower housing. See the instructions on "How To Install The Mower Housing".
11. Before you mow, check the blade rotation control. See the instructions on "How To Adjust The Blade Rotation Control".

HOW TO REPLACE THE SECONDARY MOWER DRIVE BELT

1. Remove the mower housing. See the instructions on "How To Remove The Mower Housing".
2. Remove the primary mower drive belt from the stack pulley.
3. Remove the two screws from the right pulley cover. Remove the right pulley cover.
4. Pull the idler pulley away from the secondary mower drive belt. Remove the belt from the idler pulley.
5. Remove the secondary mower drive belt from the right mandrel pulley.
6. Remove the secondary mower drive belt from the stack pulley.

NOTE: Replace the secondary mower drive belt with an original equipment belt. See an authorized service center in your area.

7. Install a new secondary mower drive belt. Put the belt around the bottom of the stack pulley. Make sure the secondary mower drive belt is inside the belt guide next to the stack pulley.
8. Put the secondary mower drive belt around the right drive pulley.
9. Pull the idler pulley toward the front. Install the flat side of the secondary mower drive belt against the idler pulley.
10. Make sure the "V" side of the secondary mower drive belt is around the right mandrel pulley.
11. Assemble the right pulley cover.
12. Put the primary mower drive belt around the stack pulley.
13. Install the mower housing. See the instructions on "How To Install The Mower Housing".
14. Before you mow, check the blade rotation control. See the instructions on "How To Adjust The Blade Rotation Control".

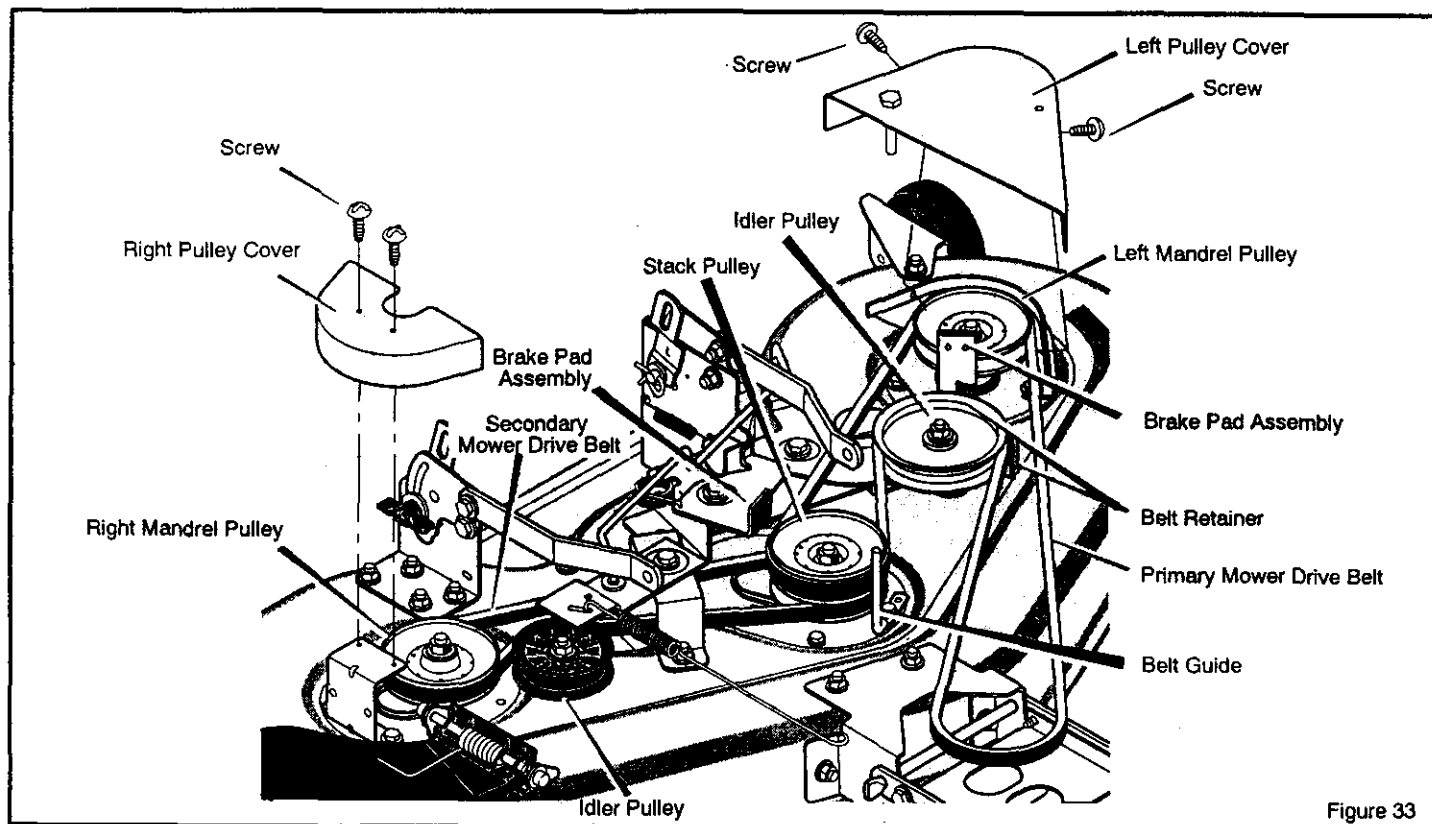
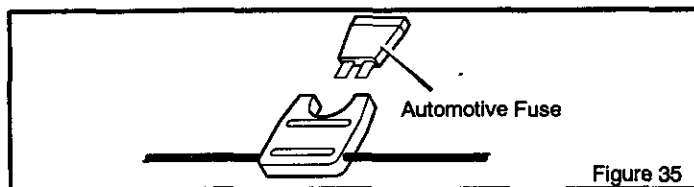
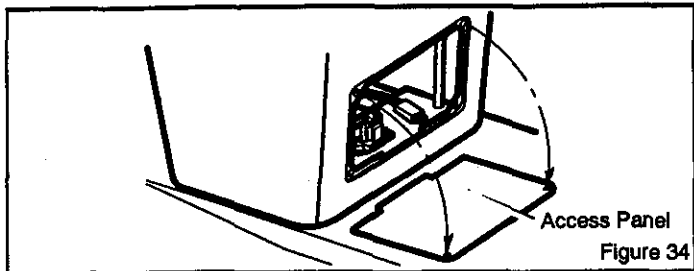

Figure 33

MAINTENANCE

HOW TO REPLACE THE FUSES

If a fuse is blown, the engine will not start. To easily access the fuse. Remove the access panel on the console as shown in Figure 34. Remove the fuse and replace with an automotive fuse (Figure 35). Replace access panel.



HOW TO REPLACE THE LIGHT BULB

1. Raise the tractor hood.
2. Turn the **light socket** until the tabs on the socket align with the notches in the **bezel** (Figure 36). Remove the **light socket**. Turn the **light bulb** and remove the bulb.
3. Install a new **light bulb**. Align the **light socket** with the notches in the **bezel** and turn the **light socket** to lock in position.

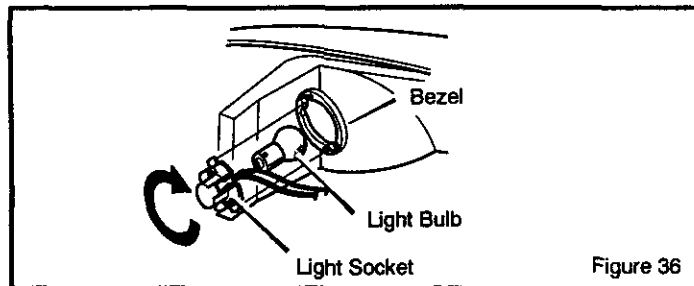

HOW TO CLEAN THE MOWER HOUSING



WARNING: Before you clean the mower housing, stop the engine and disconnect the wire to the spark plug.

Grass and other debris on top of the mower housing can keep the belt from working correctly. For safety and correct operation, frequently clean the top of the mower housing. Remove grass and debris from around the pulleys and other moving parts.

1. Move the lever for the blade rotation control to the **ENGAGE** position.
2. Clean the top of the mower housing.
3. Move the lever for the blade rotation control to the **DISENGAGE** position.
4. Again clean the top of the mower housing.
5. After you cut the grass, clean the bottom of the mower housing.

STORAGE (over 30 days)

At the end of each year, prepare the unit for storage as follows.

THE ENGINE

For storage information, see the the engine manufacturer's instructions.

THE BATTERY

1. Remove the battery.
2. Clean the battery terminals of any deposits.
3. Charge the battery. See the instructions on "How To Prepare And Charge The Battery".
4. Store the battery in a cool, dry place.

NOTE: After a long time in storage, charge the battery.

THE FUEL SYSTEM



WARNING: Do not drain the gasoline inside a building or near a fire. Do not smoke because the fumes from the fuel can cause an explosion.

1. Start the engine.
2. Run the engine until the fuel tank and the carburetor are out of fuel and the engine stops.
3. Do not leave fuel in the fuel tank or the carburetor. The fuel can damage the function of the fuel system. Some models have a **fuel drain** (Figure 37). Hold a cloth under the **fuel drain**. Push the **fuel drain** until the carburetor is empty.
4. After storage, make sure you use fresh fuel.

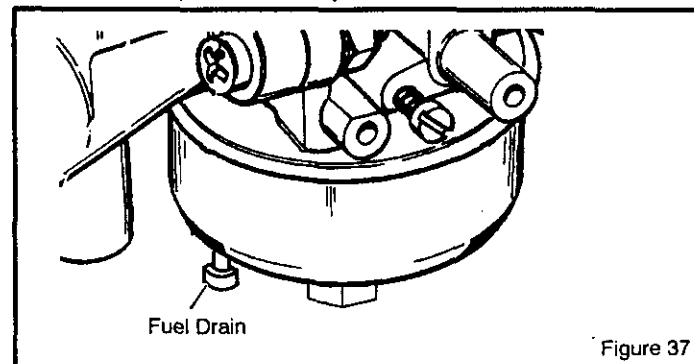

CLEAN THE UNIT

1. Clean the dirt and grass from the engine.
2. Clean the mower housing.

LUBRICATE THE UNIT

See the "Lubrication" instructions in this book.

TROUBLE SHOOTING CHART

PROBLEM: The engine will not start.

1. Follow the steps, "How To Start The Engine" in this book.
2. Electric-Start Models: Clean the battery terminals. Tighten the cables.
3. Drain the fuel tank. Clean the fuel line. Replace the fuel filter.
4. Remove the spark plug(s). Move the throttle to the SLOW position. Turn the ignition key to the ON position. Try to start the engine several times. Install the spark plug.
5. Replace the spark plug.
6. Adjust the carburetor.

PROBLEM: The engine will not turn over.

1. Follow the steps, "How To Start The Engine" in this book.
2. Electric-Start Models: Check the level of the acid in the battery. If needed, add water. Charge the battery.
3. Replace the fuse.
4. Check the wiring harness for damage or a loose connection. Repair the damaged wire.
5. Electric-Start Models: replace the solenoid. Recoil-Start Models: replace the module.

PROBLEM: The engine is difficult to start.

1. Adjust the carburetor.
2. Replace the spark plug.
3. Replace the fuel filter.

PROBLEM: The engine does not run smooth or has a loss of power.

1. Check the oil.
2. Clean the air filter.
3. Clean the air screen.
4. Replace the spark plug.
5. The engine is working too hard. Use a lower gear.
6. Adjust the carburetor.
7. Replace the fuel filter.

PROBLEM: The engine does not run smooth at fast speed.

1. Replace the spark plug.
2. Adjust the throttle control.
3. Clean the air filter.
4. Replace the fuel filter.

PROBLEM: The engine stops when the blades are engaged.

1. To activate the seat sensor, always sit in the middle of the seat.
2. Check the wiring harness for damage or a loose connection. Repair the damaged wire.

PROBLEM: On slopes, the engine stops.

1. Mow up and down slopes. Never mow across a slope.
2. To activate the seat sensor, always sit in the middle of the seat.

PROBLEM: The engine will not idle.

1. Replace the spark plug.
2. Clean the air filter.
3. Adjust the carburetor.

4. Adjust the throttle control.
5. Drain the fuel tank. Clean the fuel line. Replace the fuel filter.

PROBLEM: A hot engine causes a decrease in power.

1. Clean the air screen.
2. Check the oil.
3. Adjust the carburetor.
4. Replace the fuel filter.

PROBLEM: Excessive vibration.

1. Replace the blade.
2. Check for loose engine bolts.
3. Decrease the air pressure in the tires.
4. Adjust the carburetor.
5. Check for a damaged belt or damaged pulley. Replace the damaged parts.

PROBLEM: The grass does not discharge correctly.

1. Stop the engine. Clean the mower housing.
2. Raise the height of cut.
3. Replace or sharpen the blade(s).
4. Move the shift lever to a slower speed.
5. Move the throttle control to the FAST position.
6. Replace the spring for the blade idler.

PROBLEM: The mower housing does not cut level.

1. Check the air pressure in the tires.
2. Adjust the level of the mower housing.
3. Check the front axle. If the front axle does not freely pivot, loosen the axle bolt(s).

PROBLEM: The mower blades will not rotate.

1. Check the mower drive belt. Make sure the belt is installed correctly.
2. Replace the mower drive belt.

PROBLEM: The unit will not move when the brake is released and the speed control pedal is depressed.

1. Check the motion drive belt. Make sure the belt is installed correctly.
2. Adjust the clutch.
3. Replace the motion drive belt.
4. Release the Automatic Drive Disconnect under the seat.

PROBLEM: The unit moves slower or stops when the speed control pedal is depressed.

1. Adjust the clutch.
2. Replace the motion drive belt.

PROBLEM: When the brake pedal is released, belt noise can be heard.

1. Temporary belt noise does not change the operation of the unit. If belt noise is continuous, check the routing of the belt. Make sure the belt is inside all belt guides.
2. If the noise is continuous, adjust the clutch.

PROBLEM: The rear wheels spin over uneven terrain.

1. Check the front axle. If the front axle does not freely pivot, loosen the axle bolt(s).

SLOPE GUIDE

SIGHT AND HOLD THIS GUIDE LEVEL WITH A VERTICAL TREE, A CORNER OF A STRUCTURE, A POWER LINE POLE, OR A FENCE.

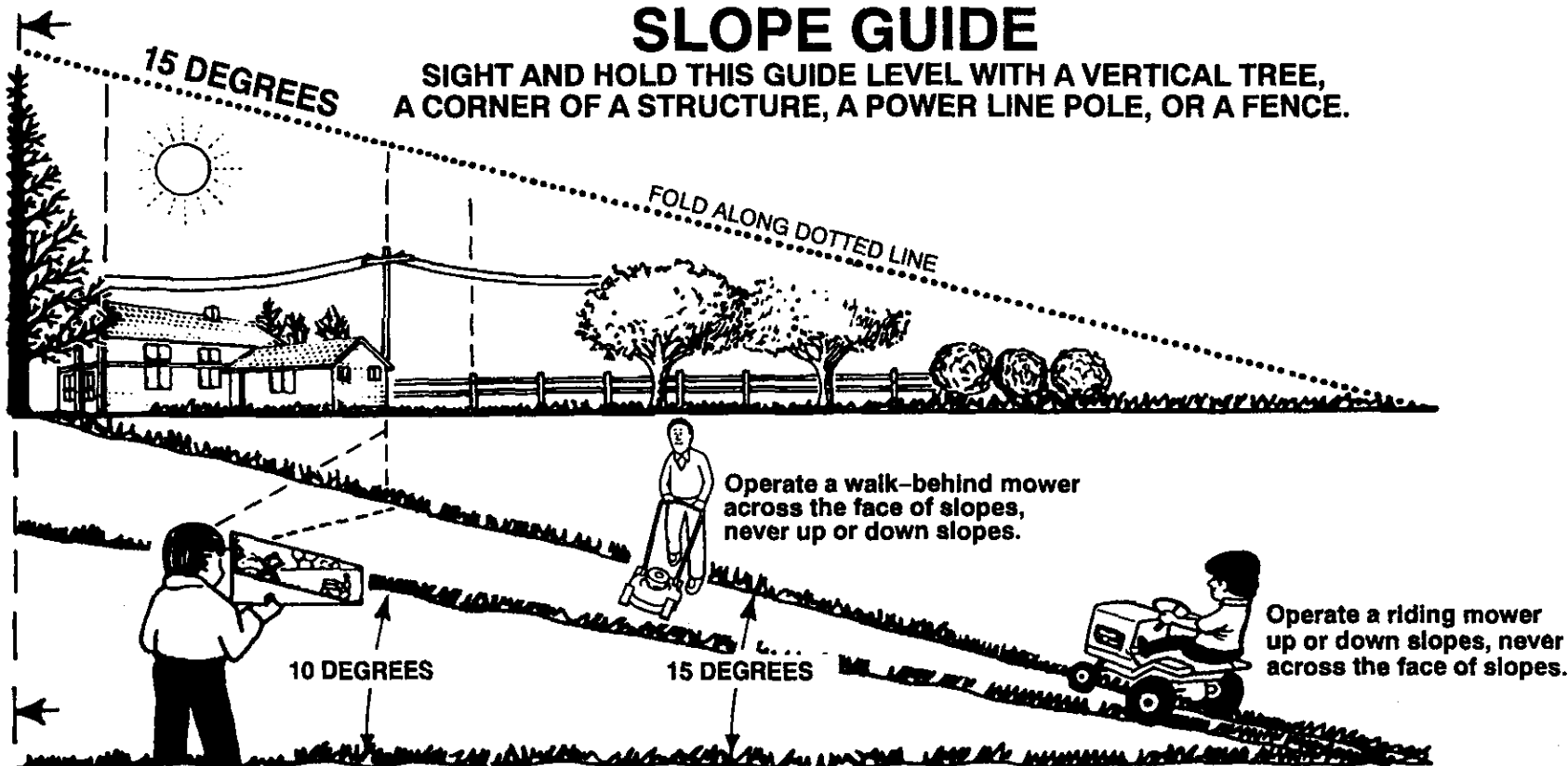

On a riding mower to determine if a slope is safe to mow: (1) disengage the blade(s), (2) put the unit in reverse, and (3) try to back straight up the slope. If you can back up the slope, it is generally safe to mow. However, if you do not feel safe, or if you are not completely sure, use this guide and do not mow a slope that is greater than 15 degrees. If the riding mower is used with a pull-behind or rear mounted attachment, do not operate the unit on a slope that is greater than 10 degrees.

A 15 degree slope is a hill that increases in height at approximately 2.5 feet in 10 feet.
A 10 degree slope is a hill that increases in height at approximately 1.7 feet in 10 feet.



Use extreme care at all times, and avoid sudden turns or maneuvers. Follow other instructions in this manual for safety in mowing on slopes. Operate a riding mower up or down slopes, never across the face of slopes. Operate a walk-behind mower across the face of slopes, never up or down slopes. Use extra care when operating on or near slopes and obstructions.

CUT HERE TO USE SLOPE GUIDE

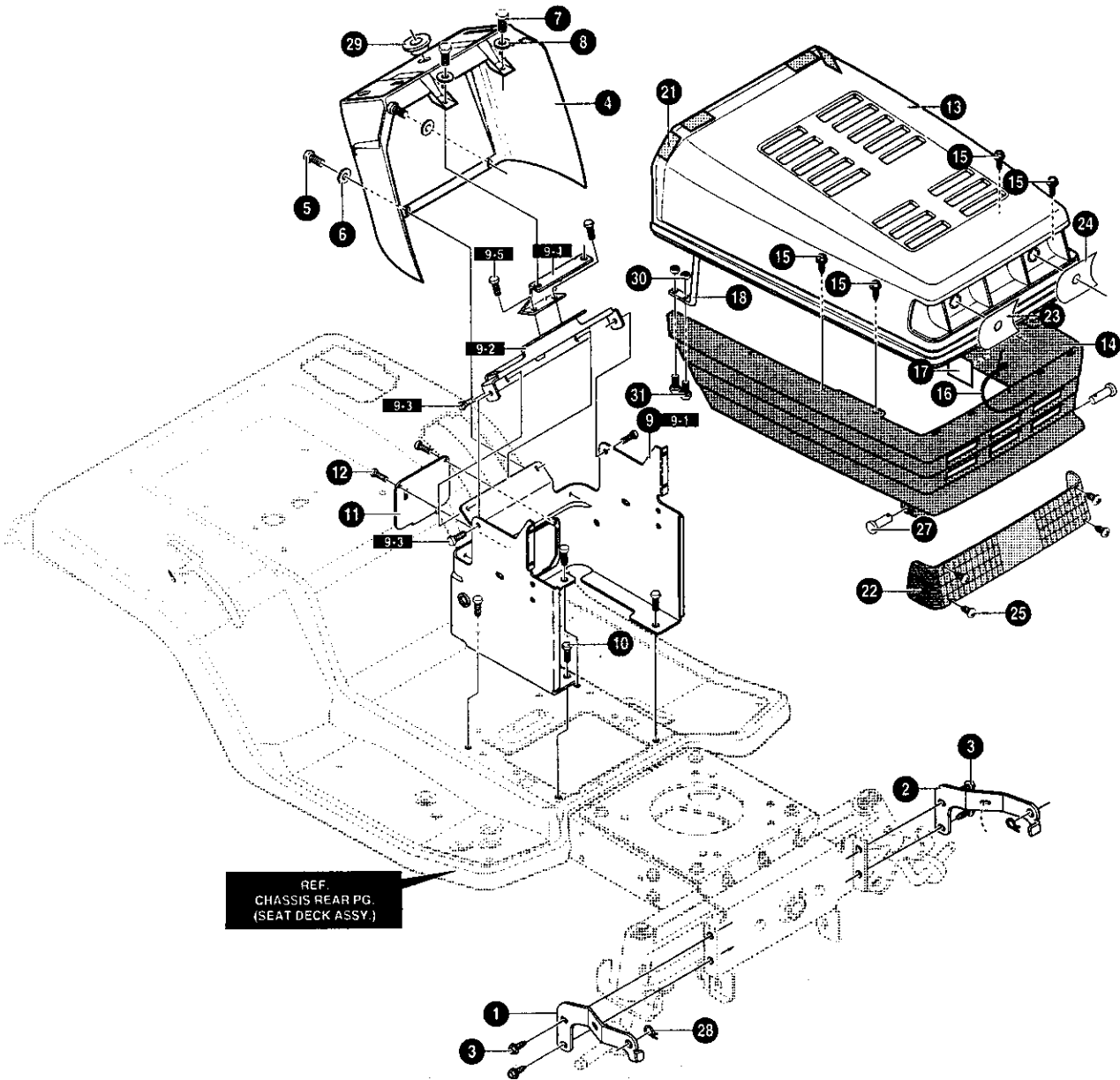

NOTE: ALWAYS USE ORIGINAL EQUIPMENT PARTS.
 Use of service/replacement parts other than original
 equipment parts may void your warranty.

ALL UNNUMBERED
 ITEMS ARE INTERCHANGEABLE
 WITH OPPOSITE SIDE

343416A

FRONT CHASSIS ASSEMBLY

KEY #	PART #	DESCRIPTION	QTY
1	94651-821	BRACKET, LH HOOD	1
2	94652-821	BRACKET, RH HOOD	1
3	711606	SCREW, 5/16-18X.75 HHWATAP	4
4	94710	DASH	1
5	711762	SCREW, 1/4-14X.75 PHPANTAP	2
6	316868	WASHER, SHOULDER NYLON .255X.46	2
7	711592	SCREW, 1/4-20X.50 WAHHTAP	1
8	316868	WASHER, SHOULDER NYLON .255X.46	2
9	341611-823	CONSOLE, LOWER ASM.	1
10	711606	SCREW, 5/16-18X.75 HHWATP	4
11	94638-823	PANEL, ACCESS WITH SLOT	1
12	711629	SCREW, 10-24X.500TRSEGI	2
13	341782	HOOD	1
14	303037	GRILLE, LOWER	1
15	711741	SCREW, #12X.50 PHPNHTAP	4
16	57444	TIE, CABLE	1
17	301452	FOIL, HEAT REFLECTOR	1
18	301425	BRACE, HOOD SUPPORT	1
21	318197	ADHESIVE, PAD	4
22	302333	LENS, CLEAR W/TAB	1
23	301540	FOIL, REFLECTOR LENS RH	1
24	301541	FOIL, REFLECTOR LENS LH	1
25	711743	SCREW, #6X.50 PLASTITE	4
27	711756	PIN, CLEVIS .500X.49/.51LGTH	2
28	711682	PIN, HAIR .38DIAX1.64LG	2
29	95404	BUSHING, STEERING SHAFT	1
30	711754	NUT, #10-24 HXHDNYLK	4
31	711753	SCREW, #10-24X1.00 HWATAP	4
	712008	OWNER'S MANUAL	

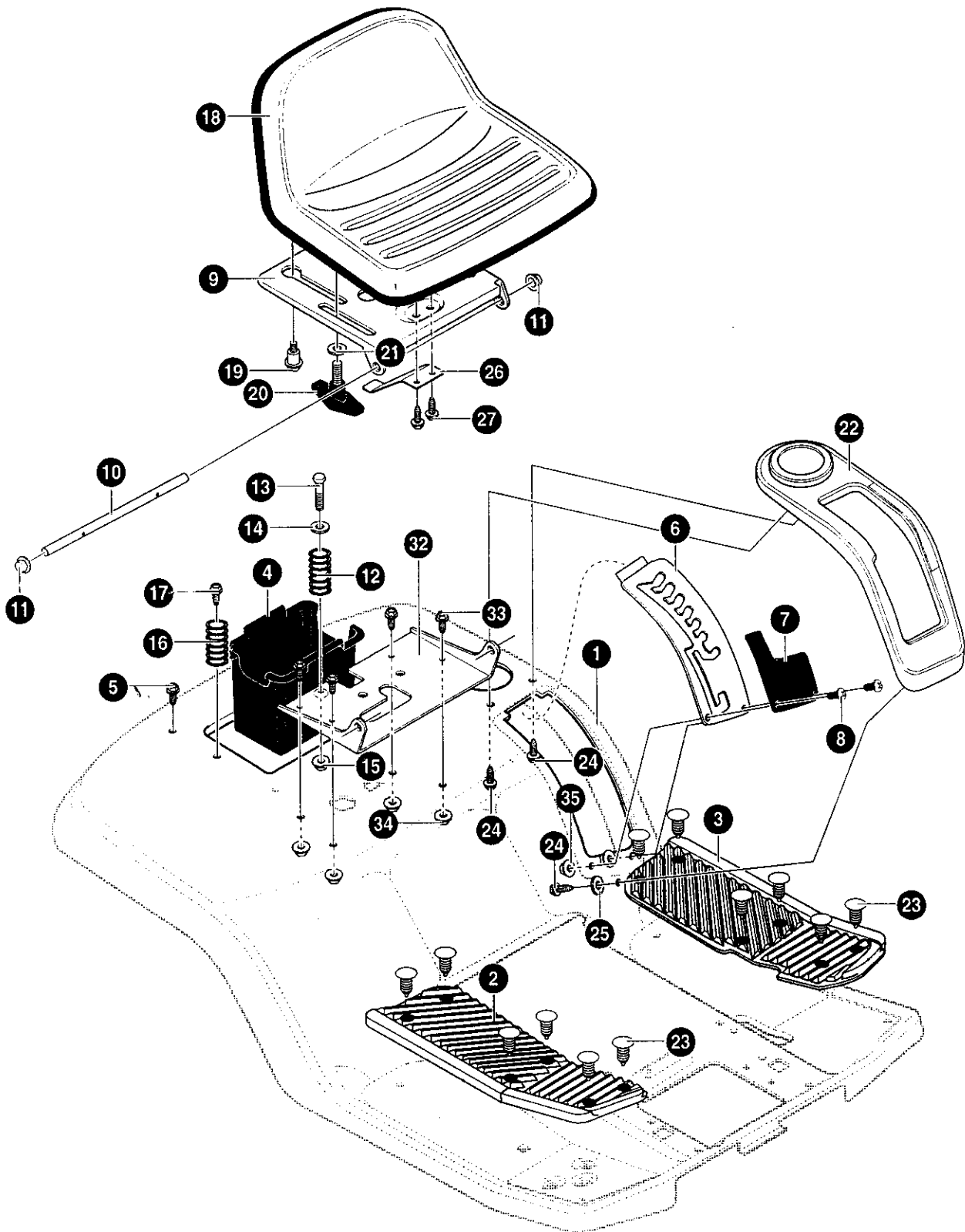

NOTE: ALWAYS USE ORIGINAL EQUIPMENT PARTS.
 Use of service/replacement parts other than original
 equipment parts may void your warranty.

ALL UNNUMBERED
 ITEMS ARE INTERCHANGEABLE
 WITH OPPOSITE SIDE

343393A

REAR CHASSIS ASSEMBLY

KEY NO.	PART NO.	DESCRIPTION	QTY
1	94629-823	SEAT DECK	1
2	95438	FOOTREST PAD RH	1
3	95437	FOOTREST PAD LH	1
4	94069	CONTAINER, BATTERY	1
5	711642	SCREW 1/4-20X.63 HHWATAPSER	2
6	94194	PLATE, LIFT DETENT LG.	1
7	94492	PLATE-DETENT LOCKOUT	1
8	711679	SCREW, .230X.135 PPANTAP10-32B	2
9	94154-823	SUPPORT, SEAT	1
10	95294	HINGE SEAT PIVOT	1
11	711627	NUT, PUSH CAP .375 (28X23)	2
12	710136	SPRING, COMPRESS 4.57LGX1.17	1
13	711610	BOLT, SHOULDER 1/4-20 NC-2A (9X55)	1
14	95293	WASHER CUP ZINC	1
15	46931	NUT, 1/4-20 WDFLLK	1
16	710109	SPRING, COMPRESS 1.43LG 164X30	2
17	711606	SCREW 5/16-18X.75 HHWATAPSGIB	2
18	95444	SEAT, MV1500	1
19	711654	BOLT, SHOULDER 5/16-18	2
20	711747	BOLT, WING 5/16-18X.50 LG THRD	2
21	711644	WASHER, FLAT .344X.62X.06	2
22	94491	COVER ,DETENT PLATE	1
23	311087	FASTENER, RATCHET	12
24	711671	SCREW, 1/4-15X.44/.53 HILOHHWA	3
25	71067	FLATWASHER, .286X.63X.065	1
26	94057	SPRING, LEAF	1
27	711592	SCREW, 1/4-20X.50 WAHHTAP	2
32	94153-823	BRACKET, PIVOT SEAT	1
33	711606	SCREW, 5/16-18X.75 HHWATAP	4
34	711634	NUT, 5/16-18 WDFLLK	4
35	314159	NUT, #10-32 CTRLK	2

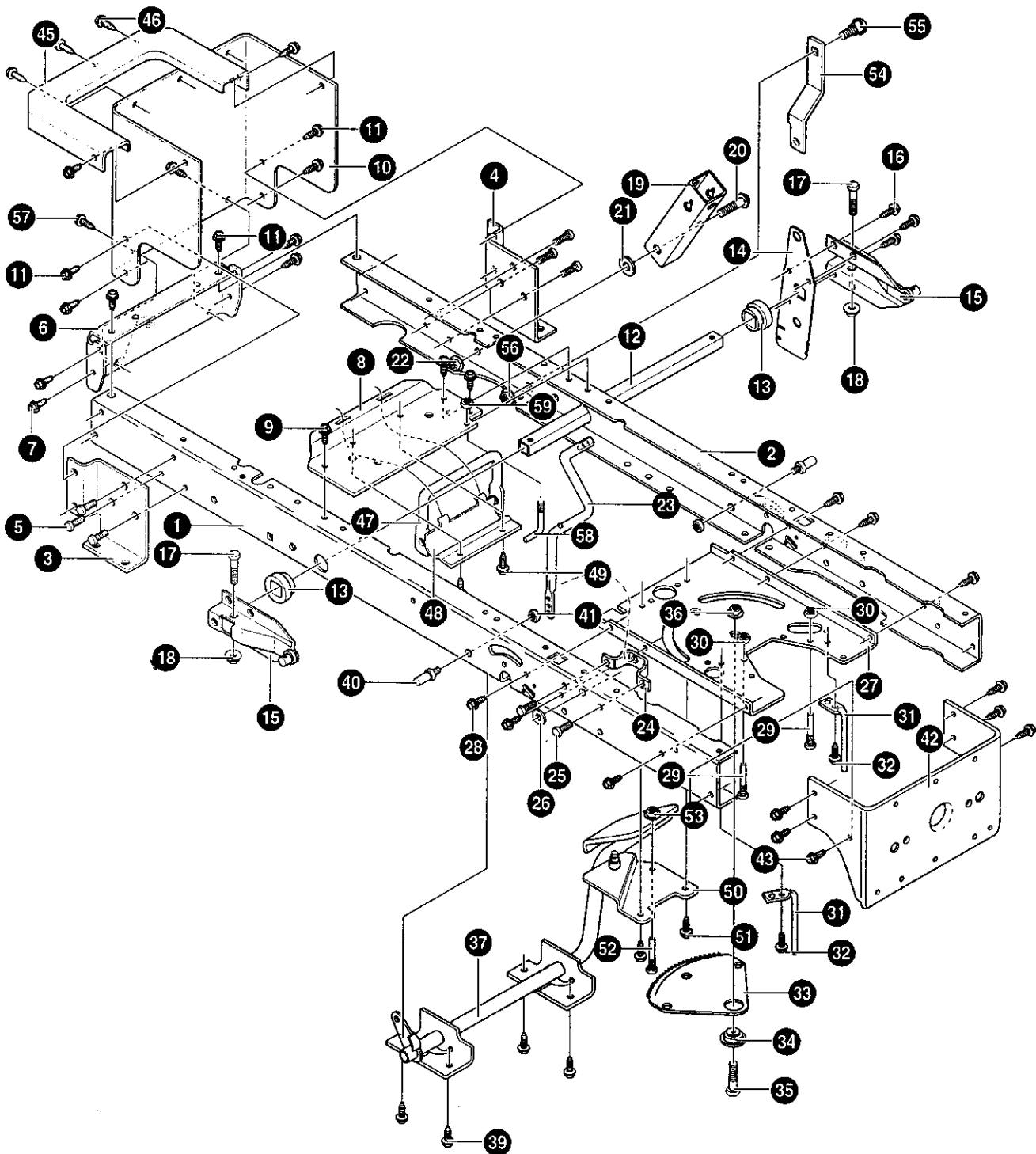

NOTE: ALWAYS USE ORIGINAL EQUIPMENT PARTS.
Use of service/replacement parts other than original
equipment parts may void your warranty.

ALL UNNUMBERED
ITEMS ARE INTERCHANGEABLE
WITH OPPOSITE SIDE

343398A

FRAME ASSEMBLY

KEY PART NO.	NO.	DESCRIPTION	QTY
1	95110	FRAME,RAIL RH	1
2	95111	FRAME,RAIL LH	1
3	94184	BRACKET, TRANSAXLE RH	1
4	94185	BRACKET, TRANSAXLE LH	1
5	710079	SCREW, 5/16-18X.75HHWATAP	6
6	94002	HITCH PLATE	1
7	710079	SCREW, 5/16-18X.75HHWATAP	4
8	94431	BRACKET, IDLER/TRUNNION SUPP	1
9	710079	SCREW 5/16-18X.75HHWATAP	3
10	94187	PLATE, REAR LARGE SEAT DECK	1
11	710079	SCREW 5/16-18X.75 HHWATAP	6
12	94063	TUBE, LIFTER	1
13	94065	BUSHING, LIFT TUBE	2
14	94030	PLATE-LIFT ARM	1
15	94180	ASSY, LIFT ARM LEVER	2
16	710106	SCREW, 5/16-18X.50WHHTAP (26X49)	3
17	710310	SCREW, 5/16-24X1.25	2
18	710080	NUT, 5/16-24 NF-2 HEXFLLK	2
19	94015	BRACKET, PIVOT	1
20	710000	BOLT, .562X1.563 HSH 3/8-16	1
21	710130	FLATWASHER .406ID (17X191)	1
22	710140	NUT, 3/8-16 HWDFLLK MACK 15X84	1
23	94019	CRANK, PTO	1
24	94005	BRACKET, BELL CRANK	1
25	710079	SCREW, 5/16-18X.75 HHWATAP	2
26	120395	FLATWASHER, .469X.92X.065	1
27	94003	PLATE, STEERING MOUNTING	1
28	710079	SCREW, 5/16-18X.75HHWATAP	6
29	93349	SCREW GUIDE 5/16-18	2
30	710204	NUT, 5/16-18 HEXWEFLLK WHIZ	2
31	91797	ROD, BELT GUIDE	1
32	710199	SCREW, 3/8-16X1.25 WAHHSPTAPP	2
33	94121	SECTOR GEAR	1
34	94123	BEARING, SECTOR GEAR	1
35	710312	SCREW, 5/16-18X1.00 HHC	1
36	710105	NUT, 5/16-8 HKEPS 15X113	1
37	94632	ASM. WELD CLUTCH/BRAKE PEDAL	1
39	710079	SCREW, 5/16-18X.75 HHWATAP	4
40	94067	PIN, THREADED SHOULDER	2
41	45171	NUT,3/8-16HWDFLWHIZ-LOCK	2
42	94013	BRACKET, HANGER REAR	1
43	710079	SCREW 5/16-18X.75HHWATAPSGIBP	6
45	94186	TOP, REAR PLATE LARGE SEAT DECK	1
46	710196	SCREW, 10-24X.500TRSEGI	5
47	94425	ROD, TRUNNION PIVOT PEERLESS	1
48	94434	CLAMP, TRUNNION PIVOT PEERLESS	2
49	710079	SCREW 5/16-18X.75HHWATAP	2
50	94409	ASSY, IDLER INTERMEDIATE IDLER	1
51	710708	BOLT, 5/16-18X.5 HXFLCA	2
52	93349	ZINC SCREW GUIDE 5/16-18	1
53	710204	NUT, 5/16-18 HEXWDFLLK WHIZ PL	1
54	94433	TORQUE STRAP - LEFT (PEERLESS)	1
55	57072	BOLT, 5/16-18X.63 CARRLN Z	1
56	710205	NUT, 5/16-18 WDFLLK (15X88)	1
57	710199	SCREW, 3/8-16X1.25 WAHHSPTAPP	2
58	94781	SCREW-GUIDE	1
59	710204	NUT, 5/16-18 HEXWDFLLK WHIZ	1

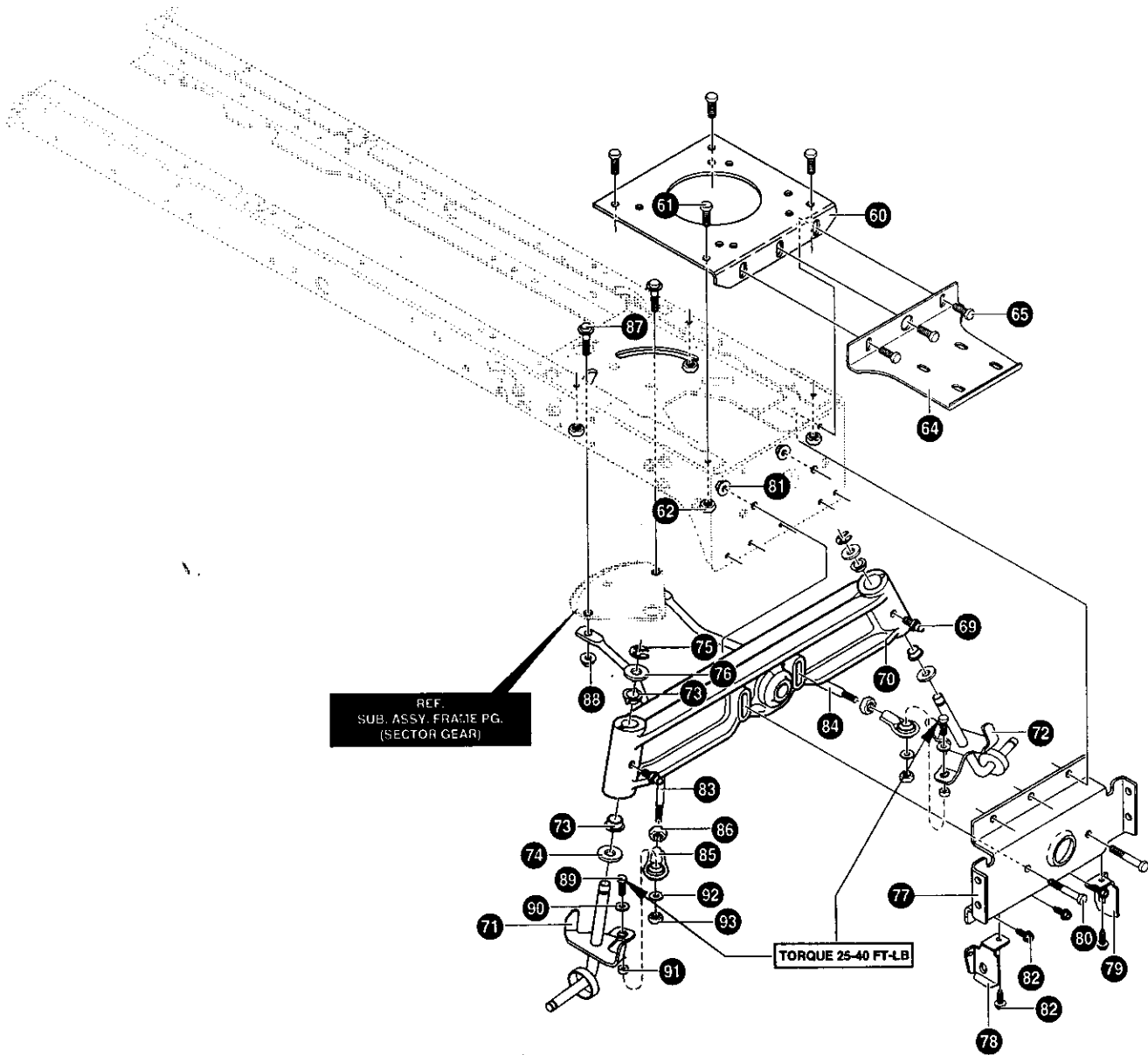

NOTE: ALWAYS USE ORIGINAL EQUIPMENT PARTS.
Use of service/replacement parts other than original
equipment parts may void your warranty.

ALL UNNUMBERED
ITEMS ARE INTERCHANGEABLE
WITH OPPOSITE SIDE

FRAME ASSEMBLY

KEY PART NO.	NO.	DESCRIPTION	QTY
60	94006	PLATE, ENGINE	1
61	710079	SCREW, 5/16-18X.75HHWATAP	4
62	710205	NUT, 5/16-18 WDFLLK (15X88)	4
64	94306	MUFFLER BRACKET	1
65	710079	SCREW, 5/16-18X.75HHWATAP	3
69	706	GREASE, ZERK FITTING	2
70	94203	AXLE, FRONT CAST IRON	1
71	94736	SPINDLE, RH/STD. SPIN/NO BRG	1
72	94737	SPINDLE, LH/STD. SPIN/NO BRG	1
73	92527	BEARING, SPINDLE	4
74	711758	FLATWASHER .765X1.81x.059	2
75	710103	E-RING, .574IDX.050/.750SH 11X3	2
76	710088	FLATWASHER .765X1.81X.059	2
77	94007	HANGER, AXLE	1
78	94026	HANGER, DECK RH	1
79	94027	HANGER, DECK LH	1
80	710081	SCREW, 5/16-24X2.75	2
81	710080	NUT, 5/16-24 NF-2 HEXFLLK	2
82	710079	SCREW, 5/16-18X.75HHWATAP	7
83	94767	ROD, DRGLINK/RH/ADJUST-5/8"	1
84	94768	ROD, DRGLINK/LH/ADJUST-5/8"	1
85	94766	TIE ROD END, 1/2-20	2
86	7058	NUT, 1/2-20 HXJAM	2
87	710440	BOLT, HSH (9X57)	2
88	710140	NUT, 3/8-16HWDFLLK MACK 15X84	2
89	310364	BOLT, .500X1.18 HSH 3/8-16	2
90	315072	FLATWASHER, .378X.75X.08HT	2
91	319618	SPACER, SLEV .515X.70C	2
92	301188	WASHER, FLAT .378X.75X.08HT	2
93	780072	NUT, 3/8-16 REGHXCTRLK	2

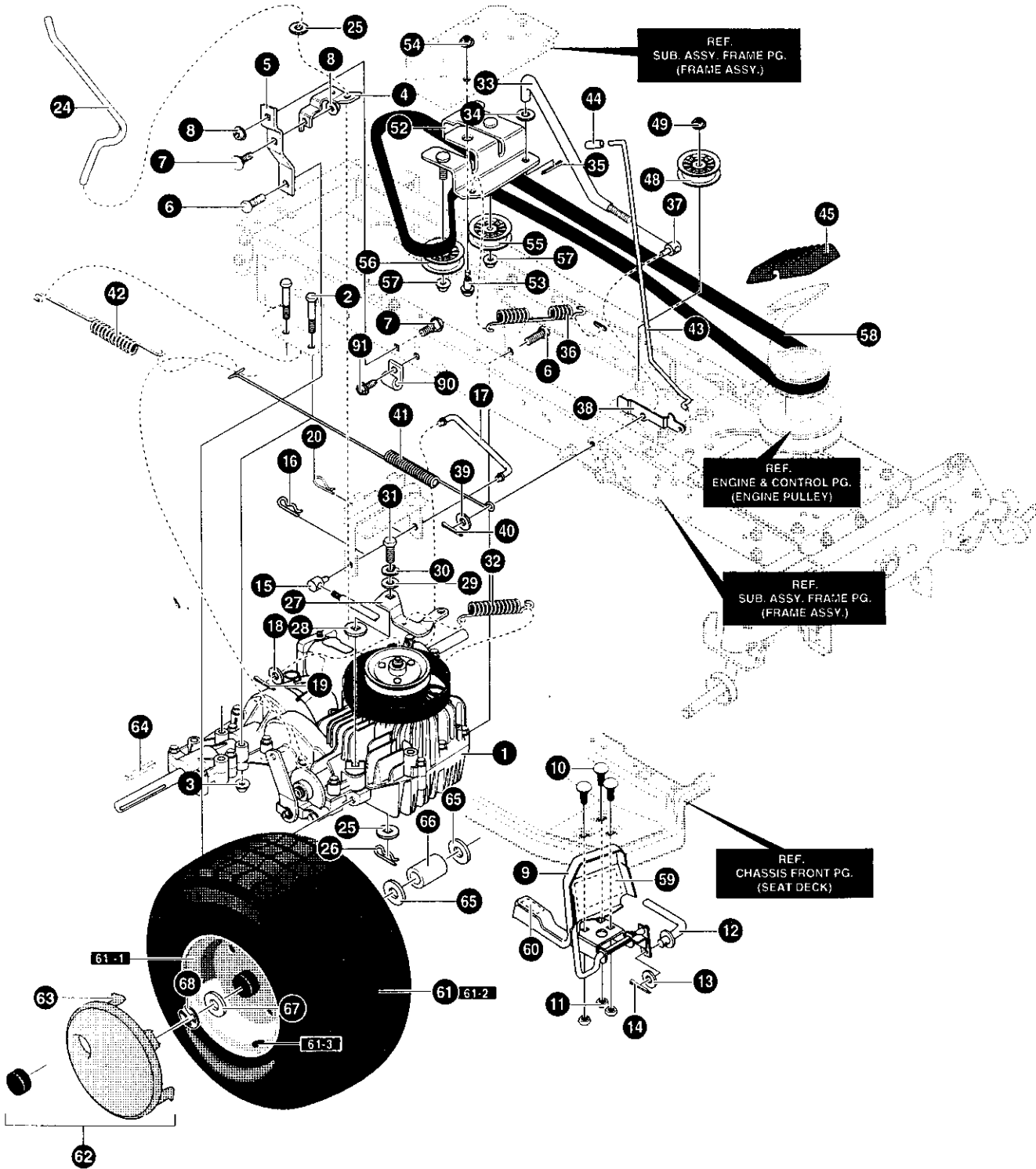

NOTE: ALWAYS USE ORIGINAL EQUIPMENT PARTS.
Use of service/replacement parts other than original
equipment parts may void your warranty.

ALL UNNUMBERED
ITEMS ARE INTERCHANGEABLE
WITH OPPOSITE SIDE

MOTION DRIVE ASSEMBLY

KEY NO.	PART NO.	DESCRIPTION	QTY
1	*	HYDRO, PEERLESS VST205-023B	1
2	711669	SCREW, 5/16-18X2.50	4
3	711634	NUT, 5/16-18 WDFLLK (15X88)	4
4	94429-821	BRACKET, DISCONNECT	1
5	94432-821	TORQUE STRAP	1
6	710268	SCREW, 5/16-18X.75 WAHTAP	2
7	711661	BOLT, 5/16-18X.63 CARRLN	2
8	711634	NUT, 5/16-18 WDFLLK (15X88)	2
9	94422-821	ASSEMBLY, PEDAL (PEERLESS)	1
10	711688	BOLT, 5/16-18X.75 CARRSN	3
11	711633	NUT, 5/16-18 HEXWDFLLK WHIZ	3
12	95278	ROD, PEDAL LINK (PEERLESS)	1
13	711761	WASHER, .469X.72	1
14	711614	PIN, COTTER	1
15	711594	ADJUSTING NUT 1/2-13	1
16	711682	PIN, HAIR .38DIAX1.64LG	1
17	95279	ROD HYDRO LINK (PEERLESS)	1
18	711617	WASHER, FLAT (17X91)	1
19	711614	PIN, COTTER .094DIAX.75 30X20	1
20	711676	PIN, HAIR (31X4)	1
24	95298	ROD HYRO LINK (PEERLESS)	1
25	711644	FLATWASHER .344X.62X.06	2
26	711614	PIN, COTTER .094DIAX.75 30X20	1
27	95299	ARM DISCONNECT	1
28	710346	WASHER .388/.393SQ.X1.00X.065	1
29	710657	WASHER, FLAT .256X.75X.130Z	1
30	710249	WASHER, (18X32)	1
31	710345	SCREW 1/4-28X.750HHCNYLK	1
32	710330	SPRING, EXTENSION 2.26LG	1
33	95297	ROD, CLUTCH	1
34	711644	WASHER, FLAT .344X.62X.06	1
35	711614	PIN, COTTER .094DIAX.75 30X20	1
36	710707	SPRING, CLUTCH VST205 HYDRO	1
37	711596	NUT, ADJUSTING	1
38	95290	LATCH, PARK BRAKE	1
39	711623	WASHER, FLAT .406X.81X16GA	1
40	711614	PIN, COTTER .094DIAX.75 30X20	1
41	710333	SPRING, EXTENSION 23.10LG	1
42	710353	SPRING, TENS 3.984X.530	1
43	94568	ROD, PARKING BRAKE	1
44	91079	KNOB, PARKING BRAKE	1
45	94630	PAD, CLUTCH/BRAKE DELUX	1
48	91179	PULLEY, IDLER 2.75	1
49	711622	NUT, 3/8-16 HWDFFLLK MACK 15X84	1
52	95305	ASM BRACKET IDLER	1
53	711613	BOLT .50X.75 HSH 3/8-16 9X39	1
54	711622	NUT, 3/8-16 HWDFFLLK MACK 15X84	1
55	91179	PULLEY, IDLER 2.75 DIA	1
56	91178	PULLEY, V-IDLER 3"	1
57	711622	NUT, 3/8-16 HWDFFLLK MACK 15X84	2
58	710531	BELT, MOTION DRIVE HYDRO 37X61	1
59	93248	PEDAL, PAD SANDPAPER	1
60	93249	PAD, TOE SANDPIPER	1
61	94756	TIRE & RIM 23X9.5-12	2
61-1	342118	RIM	2
61-2	342117	TIRE	2
61-3	338512	VALVE STEM	2
62	94618	HUB CAP AXLE SHAFT	2
64	52928	KEY SQUARE .187SQX2.25LG	1
65	711648	WASHER, FLAT .765X1.62X.065Z	4
66	95274	SPACER, .87X1.78 #87X105	2
67	711758	WASHER, FLAT .765X.81X.059	2
68	710103	RING, "E"	2
90	711742	RETAINER, .311DX.62X.03 WIRE	1
91	711606	SCREW, 5/16-18X.75	1

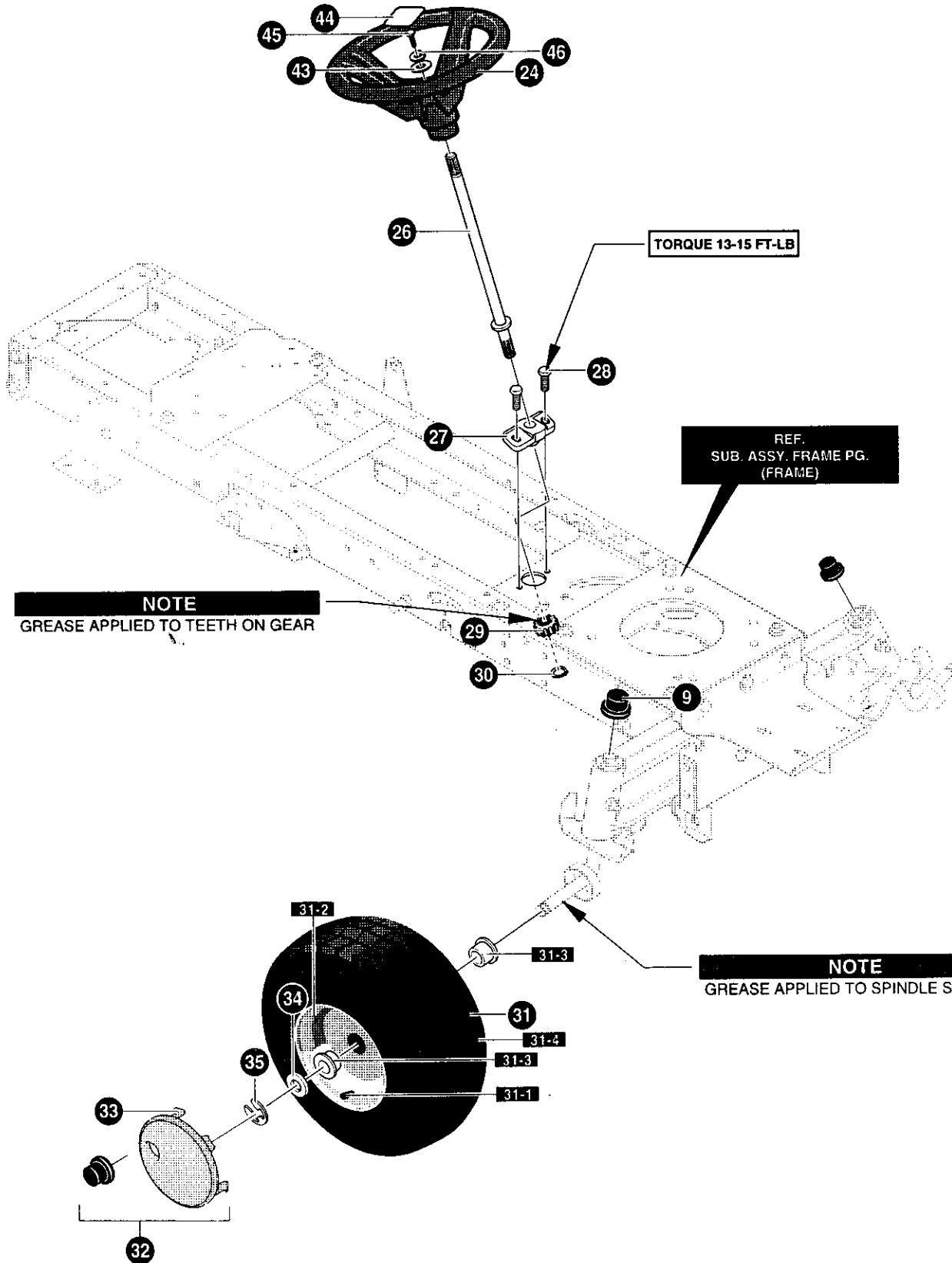

NOTE
GREASE APPLIED TO TEETH ON GEAR

TORQUE 13-15 FT-LB

REF.
SUB. ASSY. FRAME PG.
(FRAME)

NOTE
GREASE APPLIED TO SPINDLE SHAFT

NOTE: ALWAYS USE ORIGINAL EQUIPMENT PARTS. Use of service/replacement parts other than original equipment parts may void your warranty.

ALL UNNUMBERED ITEMS ARE INTERCHANGEABLE WITH OPPOSITE SIDE

STEERING ASSEMBLY

KEY NO.	PART NO.	DESCRIPTION	QTY
9	94618	HUB CAP	2
24	95228	STEERING WHEEL	1
26	94520	SHAFT, STEERING	1
27	94124	BEARING-LOWER	1
28	711606	SCREW, 5/16-18X.75HHWATAPSGIBP	2
29	94122	GEAR PINNION	1
30	710102	RING, RET E.54ID .59SH (11X25)	1
31	94755	TIRE & RIM 16X6.5-8	2
31-1	338512	VALVE STEM	2
31-2	342115	RIM, CARLISLE	2
31-3	338513	BEARING	2
31-4	342116	TIRE, 16X6.5X8	2
32	94618	HUBCAP	2
34	711758	WASHER, FLAT .765X1.62X.065Z	2
35	710103	"E" RING	2
43	711720	WASHER, FLAT .281X1.25X.06	1
44	95322	INSERT, STEERING WHEEL HUB	1
45	711719	SCREW, 1/4-20X.75 HHC	1
46	710249	WASHER, (18X32)	1

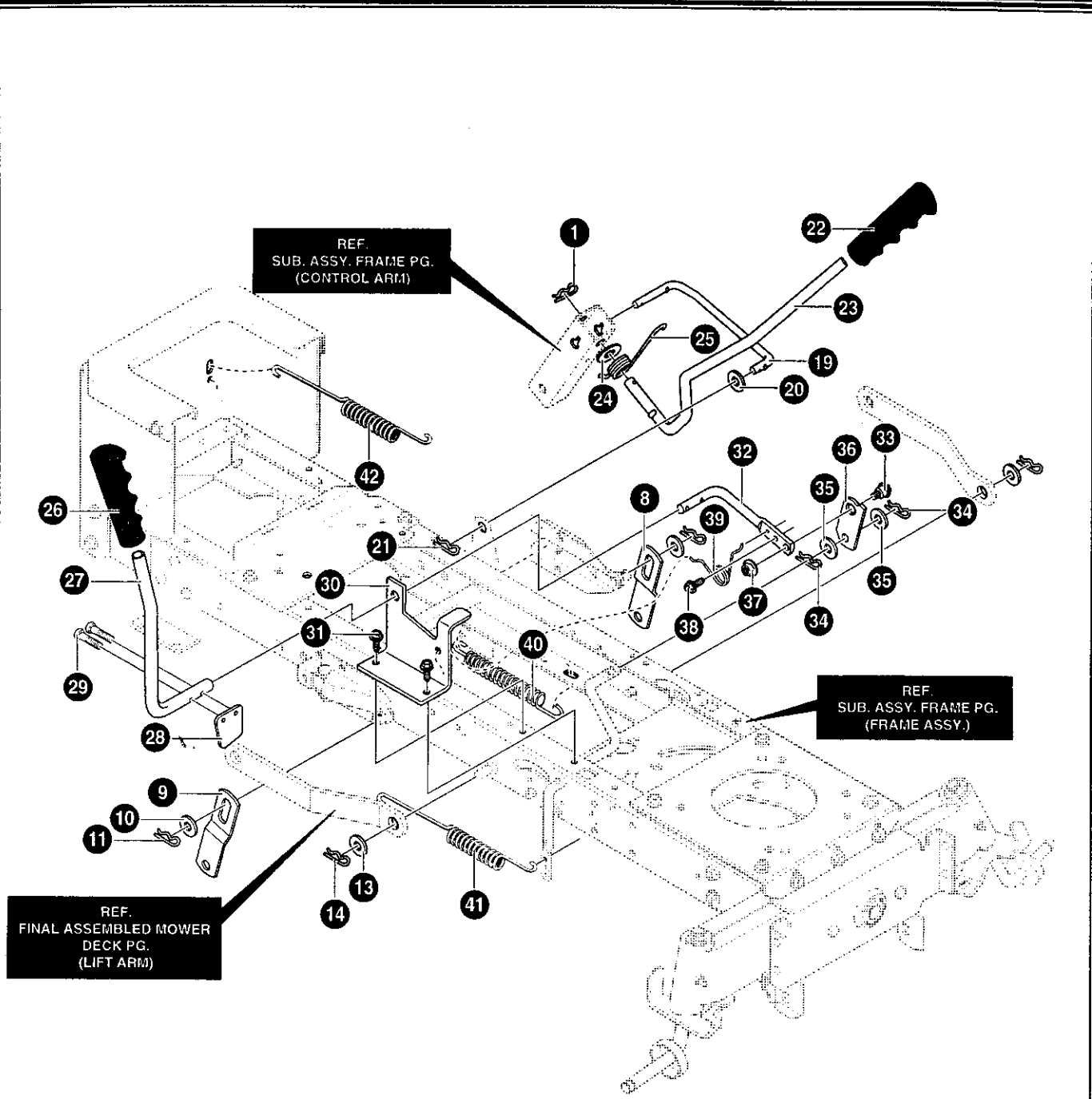

NOTE: ALWAYS USE ORIGINAL EQUIPMENT PARTS. Use of service/replacement parts other than original equipment parts may void your warranty.

ALL UNNUMBERED ITEMS ARE INTERCHANGEABLE WITH OPPOSITE SIDE

MOWER SUSPENSION ASSEMBLY

KEY NO.	PART NO.	DESCRIPTION	QTY
1	711676	HAIR PIN	1
8	94858-821	LINK, LIFT LH EXTENDED	1
9	94857-821	LINK, LIFT RH EXTENDED	1
10	711617	FLATWASHER	2
11	711676	HAIR PIN	2
13	711617	FLATWASHER	2
14	711676	HAIR PIN	2
19	95285	LINK LIFT HANDLE	1
20	711617	WASHER, FLAT	1
21	711676	PIN, HAIR	1
22	94506	GRIP, LIFT 1/2" ID	1
23	95296	HANDLE, LIFT	1
24	711616	WASHER, FLAT .550X1.00X11 (17X103)	1
25	710111	TORSION SPRING, .657LG (166X40)	1
26	94505	GRIP, PTO	1
27	690051	HANDLE, PTO	1
28	95284	PADDLE, SWITCH	1
29	711621	SCREW, THD FORM	2
30	94018-821	BRACKET, PTO	1
31	780055	SCREW, 5/16-18X.50	2
32	95283	LEVER, PTO	1
33	711613	BOLT, 3/8-16 HHSH	1
34	711659	PIN, HAIR .072DIAX1.13LG	1
35	711615	FLATWASHER, .518X.87X.16	2
36	95282	LINK, PTO	1
37	711622	NUT, 3/8-16 HWD FLLK MACK	1
38	711606	ACREW, 5/16-18X.75 HHWATAP	1
39	710141	TORSION, SPRING .33LG	1
40	710311	SPRING, TENSION 1.01OD 8.18LG	1
41	710736	SPRING, TENSION .96X3.85X15.33	1
42	710852	SPRING, EXT 8.12LG (165X125)	1

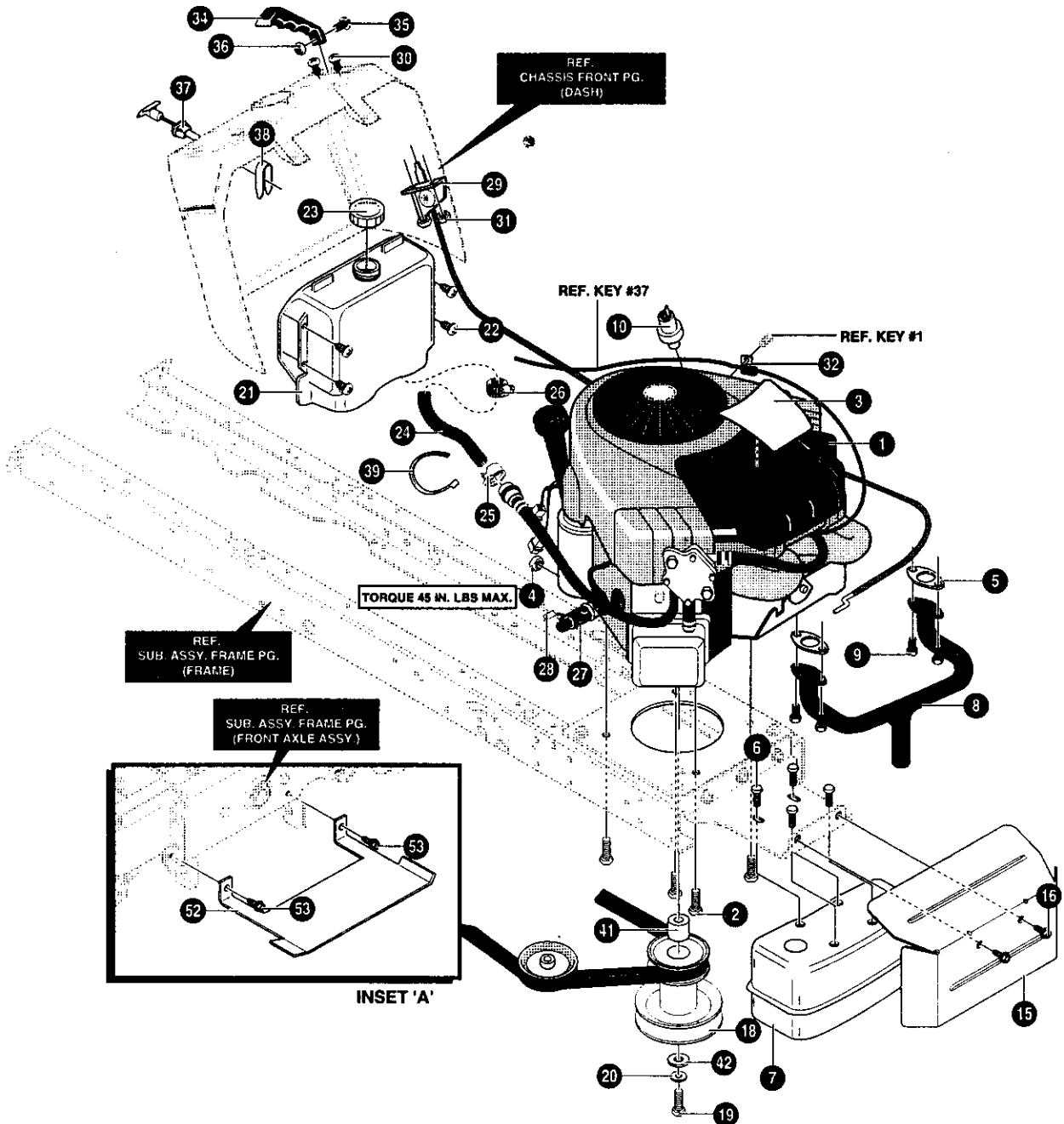

NOTE: ALWAYS USE ORIGINAL EQUIPMENT PARTS. Use of service/replacement parts other than original equipment parts may void your warranty.

ALL UNNUMBERED ITEMS ARE INTERCHANGEABLE WITH OPPOSITE SIDE

343501A

ENGINE & CONTROL ASSEMBLY

KEY PART NO. NO.	DESCRIPTION	QTY	
1	ENGINE	1	
2	710199	SCREW, 3/8-16X1.25 WAHHSPTAPP	4
3	711722	DECAL, ENGINE	1
4	711601	NUT, 1/4-20 REGHEXJAM	1
5	711851	EXHAUST GASKET B/S #273485	2
6	711660	SCREW, 1/4-20X.75 WAHHTAP	4
7	94655	MUFFLER, TWIN-CYLINDER	1
8	95204	EXHAUST TUBE	1
9	711852	SCREW (B/S 94755)	4
10	314797	OIL SENSOR	1
15	94335-821	SHIELD, HEAT ASSY.	1
16	711606	SCREW, 5/16-18X/75 HHWATAP	2
18	95266	PULLEY STACK ASSY.	1
19	120383	WASHER, REGSPTLK .459X.78X.12	1
20	710248	SCREW, 7/16-20 NF 1.50	1
21	314991	TANK, FUEL 2 GAL	1
22	711741	SCREW, #12X.50 PHPNTAP	4
23	300304	CAP, GAS 2.0 THROAT	1
24	57876	TUBING, GAS LINE	13 INCHES
25	47345	CLAMP, HOSE SCREW TYPE	1
26	47345	CLAMP, HOSE SCREW TYPE	2
27	325547	OIL DRAIN VALVE ASSEMBLY	1
28	327422	CAP, OIL DRAIN VALVE ASSY	1
29	309407	THROTTLE CONTROL	1
30	711755	SCREW, #10-24X.63 PHPNMA	2
31	711754	NUT, 10-24 HXHDNYLK	2
32	711742	RETAINER, .31IDX.62X.03 WIRE	1
34	94931	KNOB, THROTTLE CONTROL	1
35	711750	SCREW, #8-32 X.38 PHPNMA	1
36	711748	NUT, #8-32 REGHX	1
37	94891	CHOKE	1
38	314522	CLIP, CHOKE CONTROL	1
39	57444	CABLE TIE	1
41	93077	SPACER, SLEV 1.015IDX1.77OD	1
42	710247	WASHER, FLAT .480X1.00X.25	1
52	95192-821	SHIELD, ANTI-DEHYDRATION DEFLEC	1
53	711606	SCREW 5/16-18X.75 HHWATAP	2

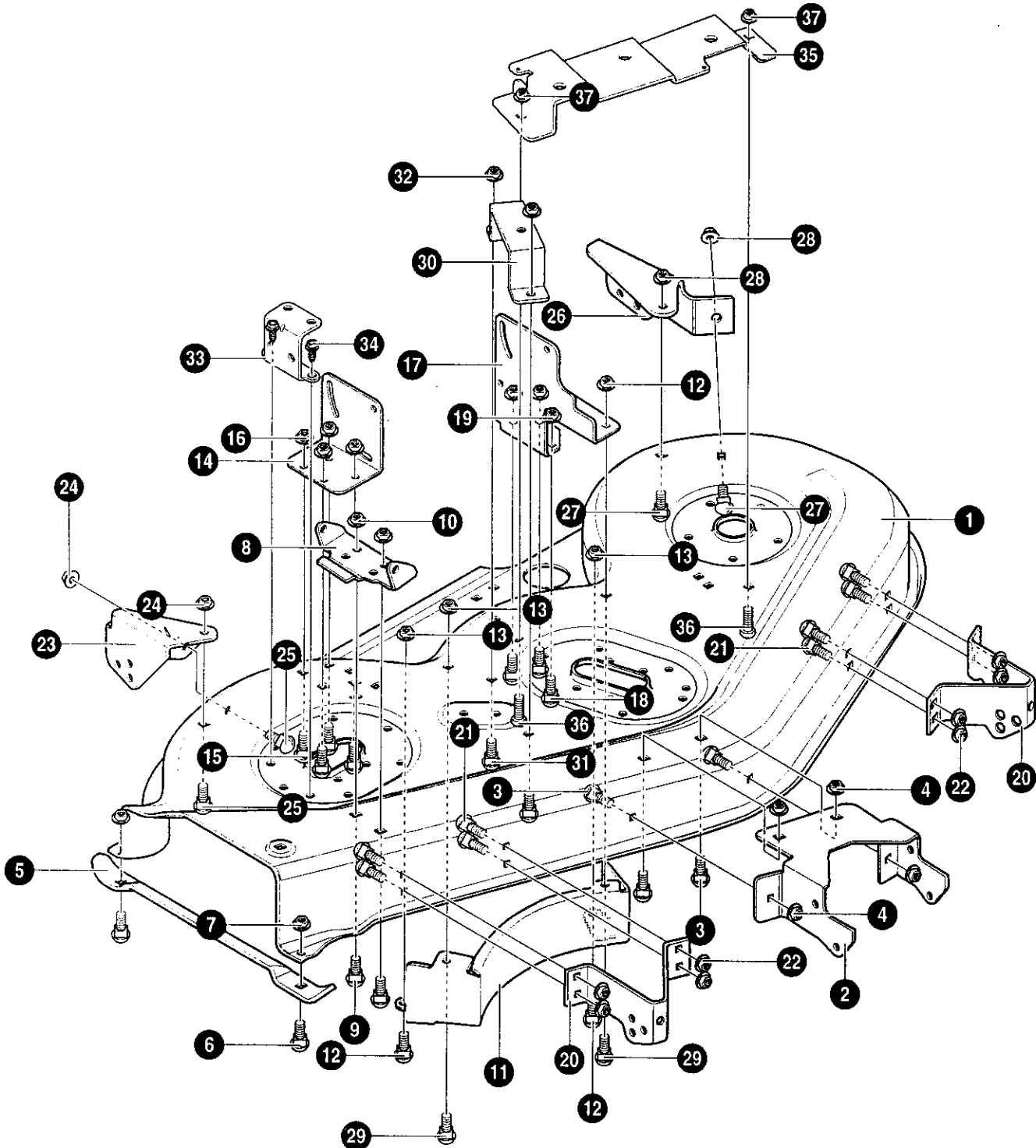

NOTE: ALWAYS USE ORIGINAL EQUIPMENT PARTS.
Use of service/replacement parts other than original
equipment parts may void your warranty.

ALL UNNUMBERED
ITEMS ARE INTERCHANGEABLE
WITH OPPOSITE SIDE

341592A

PRE-PAINTED DECK ASSEMBLY

KEY NO.	PART NO.	DESCRIPTION	QTY
1	94663	BLADE HOUSING 50"	1
2	94693	BRACKET, FRONT DECK	1
3	57072	BOLT, 5/16-18X.63 CARR.	4
4	710204	NUT, 5/16-18 HEXWDFLLK WHIZ	4
5	95176	BRACKET, CHUTE SUPPORT	1
6	57072	BOLT, 5/16-18X.63 CARR.	2
7	710205	NUT 5/16-18 WDFLLK (15X88)	2
8	92104	HINGE, CHUTE BRACKET	1
9	57072	BOLT 5/16-18X.63 CARR.	2
10	710205	NUT, 5/16-18 WDFLLK (15X88)	2
11	94825	BAFFLE, CENTER 50"	1
12	57072	BOLT, 5/16-18X.63 CARR.	4
13	710204	NUT, 5/16-18 HEXWDFLLK WHIZ	4
14	94694	BRACKET, LIFTER RH	1
15	57072	BOLT, 5/16-18X.63 CARR.	4
16	710204	NUT 5/16-18 HEXWDFLLK WHIZ	4
17	94695	BRACKET, LIFTER LH	1
18	57072	BOLT, 5/16-18X.63 CARR.	4
19	710204	NUT, 5/16-18 HEXWDFLLK WHIZ	4
20	95180	BRACKET, GAGE WHEEL FRONT	1
21	57072	BOLT, 5/16-18X.63 CARR.	8
22	710204	NUT, 5/16-18 HEXWDFLLK WHIZ	8
23	94716	BRACKET, GAGE WHEEL RH	1
24	710204	NUT, 5/16-18 HEXWDFLLK WHIZ	2
25	57072	BOLT, 5/16-18X.63 CARR.	2
26	94717	BRACKET, GAGE WHEEL LR	1
27	57072	BOLT, 5/16-18X.63 CARR.	2
28	710204	NUT, 5/16-18 HEXWDFLLK WHIZ	2
29	710079	SCREW, 5/16-18X.75HHWATAP	2
30	94601	BRACKET, BELL CRANK	1
31	57072	BOLT, 5/16-18X.63 CARR.	2
32	710204	NUT, 5/16-18 HEXWDFLLK WHIZ	2
33	92140	BRACKET, PULLEY COVER	1
34	710079	SCREW, 5/16-18X.75 HHWATAP	2
35	94699	BRACKET, BRAKE MT	1
36	57072	BOLT, 5/16-18X.63 CARR.	2
37	710204	NUT, 5/16-18 HEXWDFLLK WHIZ	2

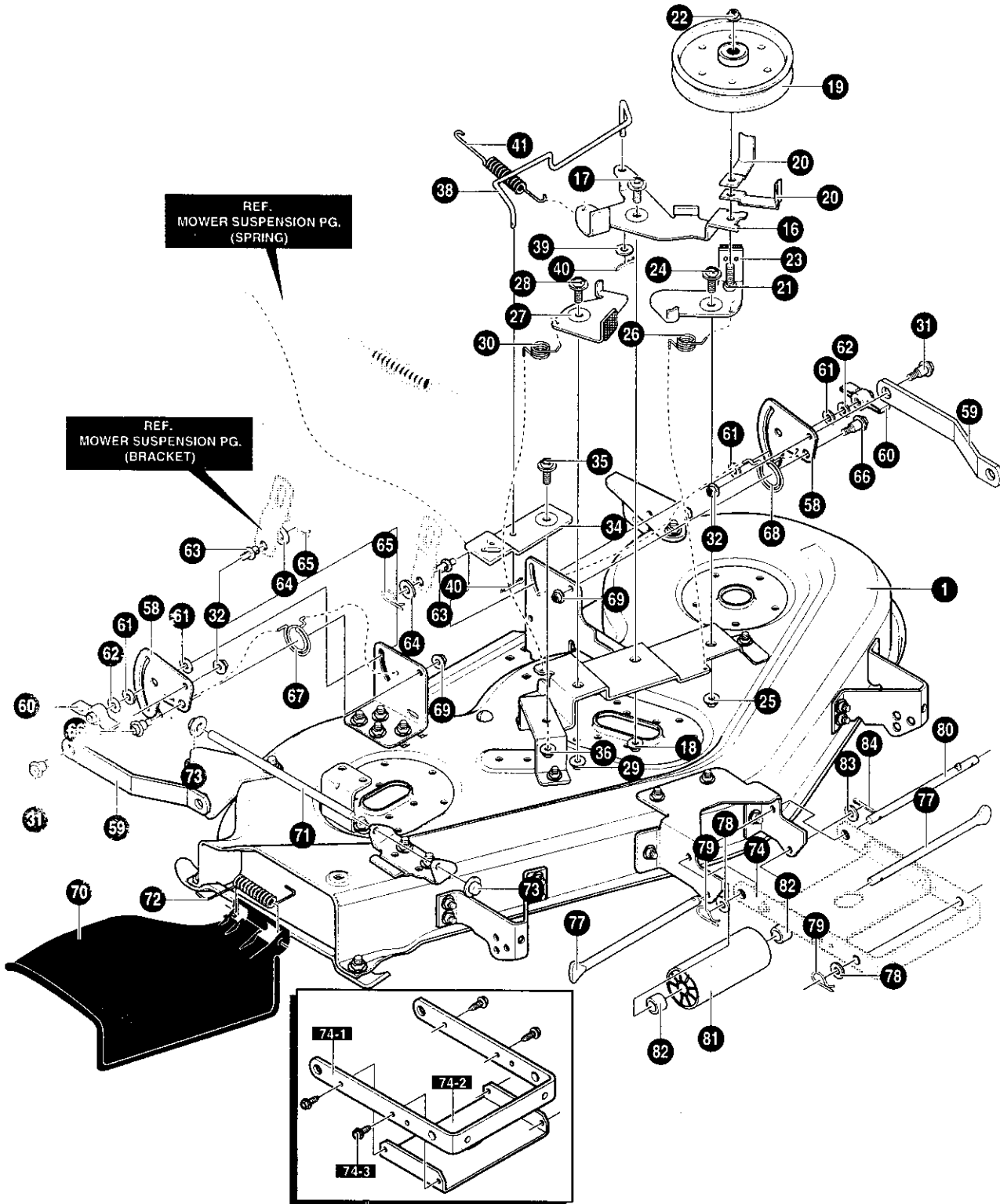

NOTE: ALWAYS USE ORIGINAL EQUIPMENT PARTS. Use of service/replacement parts other than original equipment parts may void your warranty.

ALL UNNUMBERED ITEMS ARE INTERCHANGEABLE WITH OPPOSITE SIDE

343418A

DECK ASSEMBLY

KEY NO.	PART NO.	DESCRIPTION	QTY
1	341592-821	ASM, BLADE HOUSING 50"	1
16	94702-821	ARM, IDLER CLUTCHING 50"	1
17	711613	BOLT, .50X.75 HHSH 3/8-16 9X39	1
18	711622	NUT, 3/8-16 HWDFLK MACK 15X84	1
19	95272	IDLER PULLEY 5"	1
20	94809	SPRING, BELT GUIDE	2
21	711609	SCREW 3/8-16X2.00	1
22	711622	NUT 3/8-16 HWDFLK MACK 15X84	1
23	94697-821	ASM. BRAKE ARM & PAD LH	1
24	711613	BOLT, .50X.75HHSH 3/8-16	1
25	711622	NUT, 3/8-16 HWDFLK MACK	1
26	710227	TORSION SPRING .55LG (166X41)	1
27	94698-821	ASM. BRAKE ARM & PAD CENTER	1
28	711613	BOLT, .50X.75HHSH 3/8-16	1
29	711622	NUT, 3/8-16 HWDFLK MACK	1
30	710227	TORSION SPRING .55LG (166X41)	1
31	711612	BOLT, SHOULDER 3/8-16 (9X52)	2
32	711622	NUT, 3/8-16 HWDFLK MACK	2
34	94808-821	BELLCRANK 50"	1
35	711613	BOLT, .50X.75HHSH 3/8-16	1
36	711622	NUT, 3/8-16HWDFLK MACK	1
38	94703	LINK, 50"	1
39	711759	WASHER, FLAT .406X.812X.06HT	1
40	711614	PIN, COTTER .094DIAX.75 30X20	2
41	710331	SPRING, TENSION 4.57LG	1
58	94128-821	PLATE SUSPENSION	2
59	94055-821	SUSPENSION BRACKET REAR	2
60	711600	WINGNUT 5/16-18	2
61	94137	PAD, FRICTION	2
62	711628	WASHER (17X45)	2
63	711595	PIN, HANGER	2
64	711616	WASHER, FLAT .550X1.00X11	2
65	711676	PIN, HAIR	2
66	711611	BOLT, SHOULDER .375 (9X51)	2
67	710112	SPRING, TORSION .68LG RH 166X42	2
68	710113	SPRING, TORSION .68LG LH 166X43	2
69	711622	NUT 3/8-16 HWDFLK MACK 15X84	2
70	92100	DEFLECTOR, DECK CHUTE	1
71	95281	ROD DEFLECTOR	1
72	710220	SPRING, TORSION	1
73	711627	NUT, PUSH CAP .375 (28X32)	2
74	690058-821	ASM., BRACKET & STIFFENER	1
74-1	94058	BRACKET, FRT SUSPENSION	1
74-2	95057	STIFFENER, FRT HANGER	1
74-3	711079	SCREW, 5/16-18X.75 HHWATAP	4
77	95295	ROD HANGER	1
78	711617	WASHER, FLAT (17X91)	1
79	711676	PIN, HAIR (31X4)	1
80	95302	ROD, ROLLER	2
81	92137	ROLLER, 6" NOSE DECK	1
82	91925	SPACER, SLEEVE	2
83	711616	WASHER, FLAT .550X1.00X11	1
84	711635	HAIR PIN 30X49	1

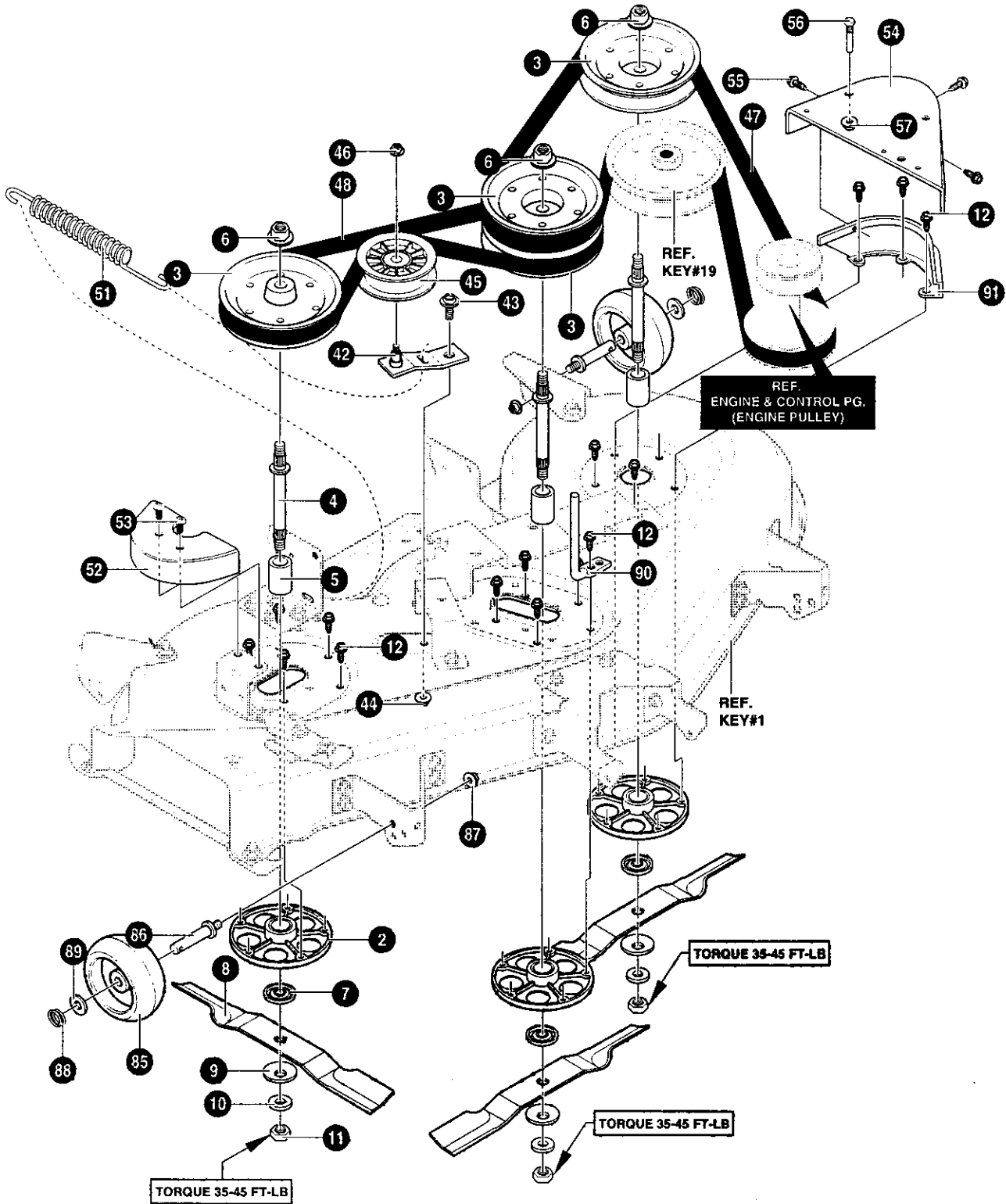

NOTE: ALWAYS USE ORIGINAL EQUIPMENT PARTS. Use of service/replacement parts other than original equipment parts may void your warranty.

ALL UNNUMBERED ITEMS ARE INTERCHANGEABLE WITH OPPOSITE SIDE

343418A

DECK ASSEMBLY

KEY NO.	PART NO.	DESCRIPTION	QTY
2	94752	ASM., JACKSHAFT, HVY DUIY	1
3	95310	PULLEY, JACKSHAFT	4
4	95402	SHAFT, SPLINED JACKSHAFT	3
5	94130	SPACER, .625X.875X1.858	3
6	711626	NUT, 9/16-18 UNF-2B 15X121	3
7	95416	HUB, BLADE ADAPTOR	3
8	94692	BLADE	3
9	710118	WASHER BELLEVILLE 17X166	3
10	710117	WASHER, FLAT .625X1.00X.188	3
11	710104	NUT, 9/16 REGHEX (15X100)	3
12	710199	SCREW, 3/8-16X1.25 WAHHSPTAPP	15
42	94701-821	ASM., IDLER ARM SECONDARY 50"	1
43	711613	BOLT .50X.75HHSH 3/8-16 9X39	1
44	711622	NUT 3/8-16 WDFLLK MACK 15X84	1
45	91590	PULLEY, IDLER	1
46	711622	NUT 3/8-16 WDFLLK MACK 15X84	1
47	710533	BELT, PRIMARY 50"	1
48	710532	BELT, SECONDARY 50" 37X92	1
51	712140	SPRING, TENSION	1
52	94607-821	COVER, PULLEY RH 50" DECK	1
53	711620	SCREW, 10-16 .190X.62 TRUSS	2
54	94645-821	PULLEY, COVER (TOP) DECK RH	1
55	711606	SCREW, 5/16-18X.75 HHWATAP	3
56	711745	SCREW GUIDE 5/16-18	1
57	711633	NUT, 5/16-18 HEXWDFLLK WHIZ	1
85	92683	GAUGE WHEEL, 4.94 DIA	4
86	711746	BOLT, SPSH 3/8-16X.63	4
87	711622	NUT, 3/8-16 HWDFFLK MACK	4
88	711764	PIN, CIRCLE	4
89	711617	WASHER, FLAT	4
90	711757	ZINC, GUIDE BELT	1
91	94643-821	BRACKET, PULLEY COVER	1

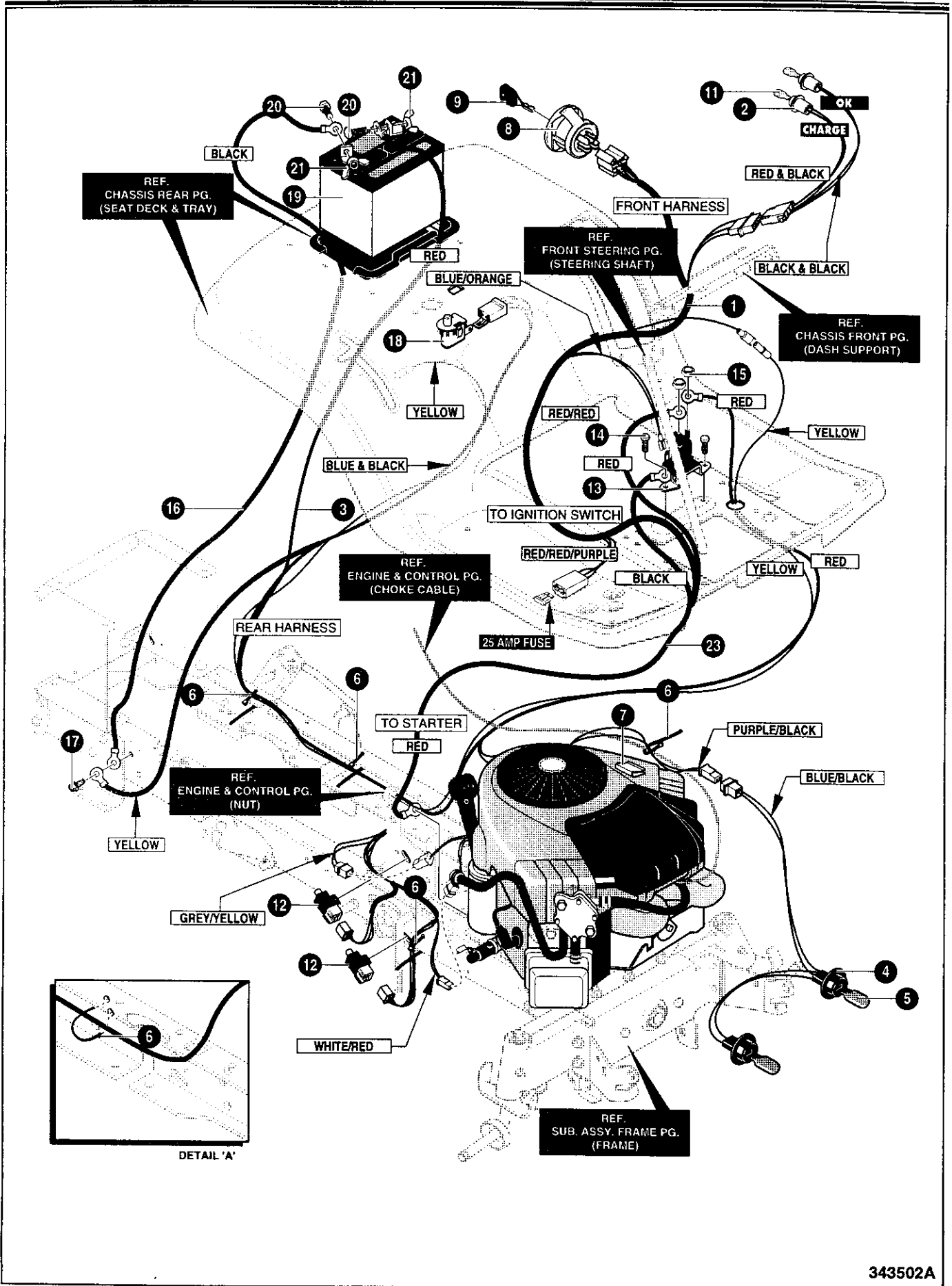

ELECTRICAL ASSEMBLY

KEY NO.	PART NO.	DESCRIPTION	QTY
1	94102	WIRE HARNESS	1
2	94739	IND. HARNESS,-OIL,CHG,PTO/CLUTCH	1
3	340530	WIRE HARNESS, REAR	1
4	94103	WIRE HARNESS FOR HEADLIGHT	1
5	52572	HEADLIGHT BULB	2
6	57444	TIE, CABLE BLACK NYLON 5.62L	4
7	55939	WIRE CLIP, ADHESIVE	2
8	94762	SWITCH, IGNITION DELTA 7 TERM	1
9	327350	KEY, IGNITION	1
11	57769	BULB INDICATOR	3
12	94136	SWITCH LIMIT DELTA	2
13	94613	SOLENOID	1
14	711619	SCREW, HHWATAP 1/4X.50	2
15	711632	NUT, 1/4-20 HEXNYL	2
16	710228	WIRE, GROUND (24X32)	1
17	711619	SCREW, HHWATAP 1/4X.50	1
18	94159	SWITCH, SEAT	1
19	302257	BATTERY 12V 7 PLATE	1
20	711680	BOLT, 1/4-20X.63CAR (2X82)	2
21	711636	NUT, WING 1/4-20 NC (14X79)	2
23	711579	WIRE, LEAD SOLENOID TO STARTER	1
	302031	FUSE 15 AMP	

SCHEMATIC WIRING

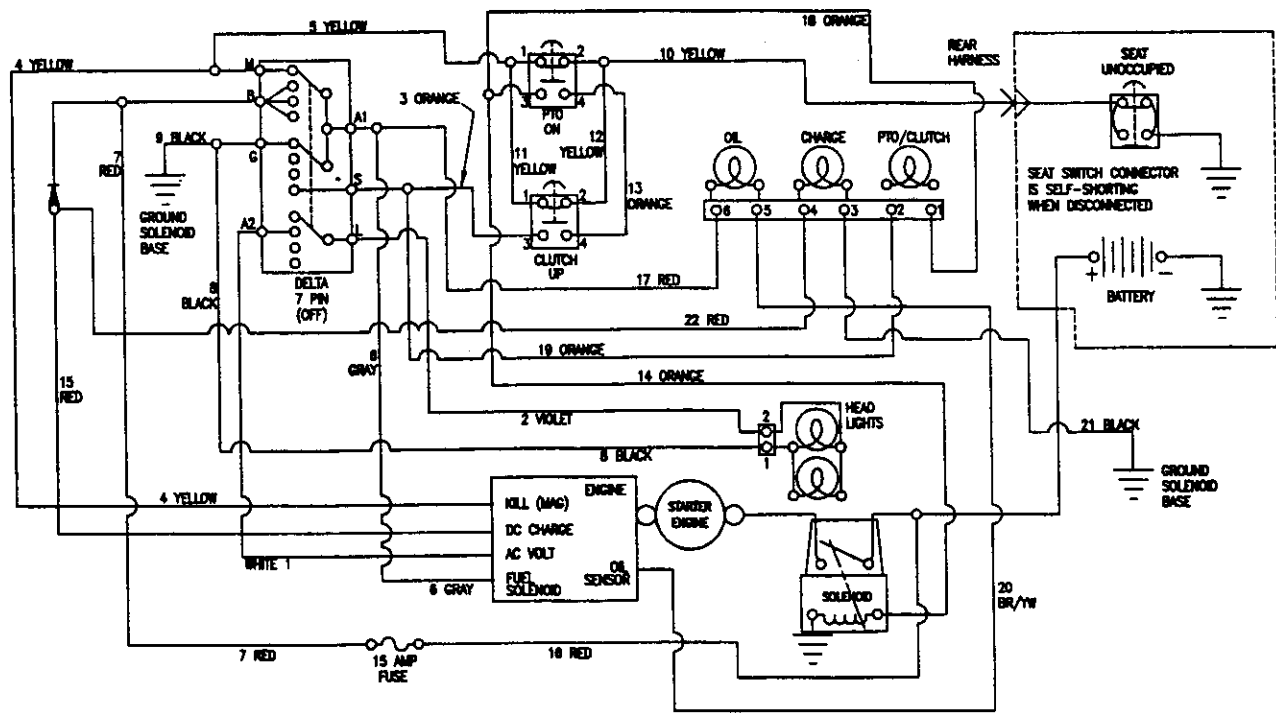

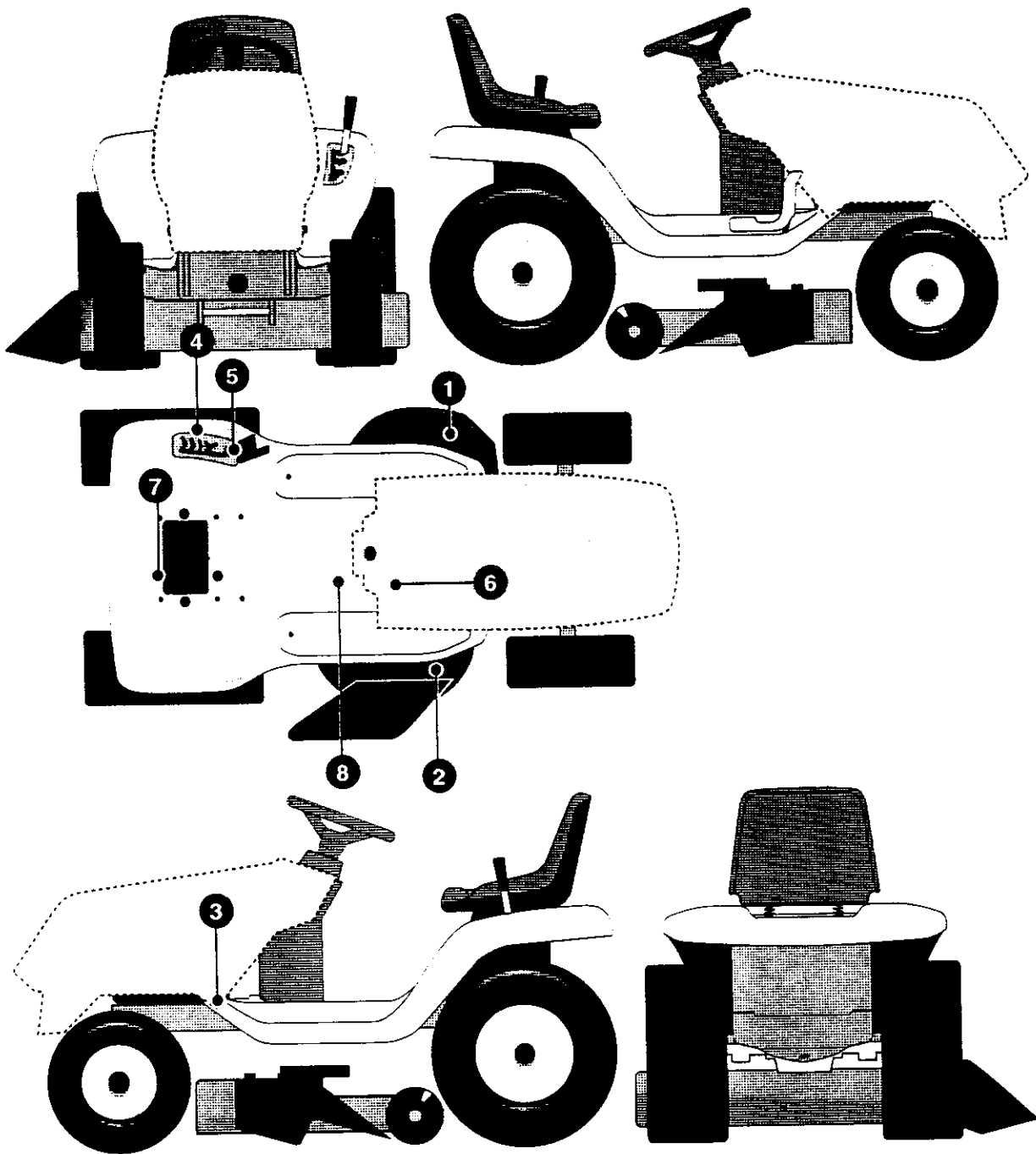

KEY NO.	PART NO.	DESCRIPTION	QTY
1	711066	DECAL, NO STEP	1
2	711469	DECAL, CUT FINGER	1
3	711301	DECAL, CL/BRAKE TOE	1
4	710638	DECAL, HEIGHT ADJUST 1-6	1
5	710639	DECAL, DECK LEVEL	1
6	710720	DECAL, AUTODRIVE INSTR DASH RT	1
7	711555	DECAL, HYDRO REL. VALVE	1
8	711468	DECAL, INSTR. CONS.	1

DECAL ASSEMBLY

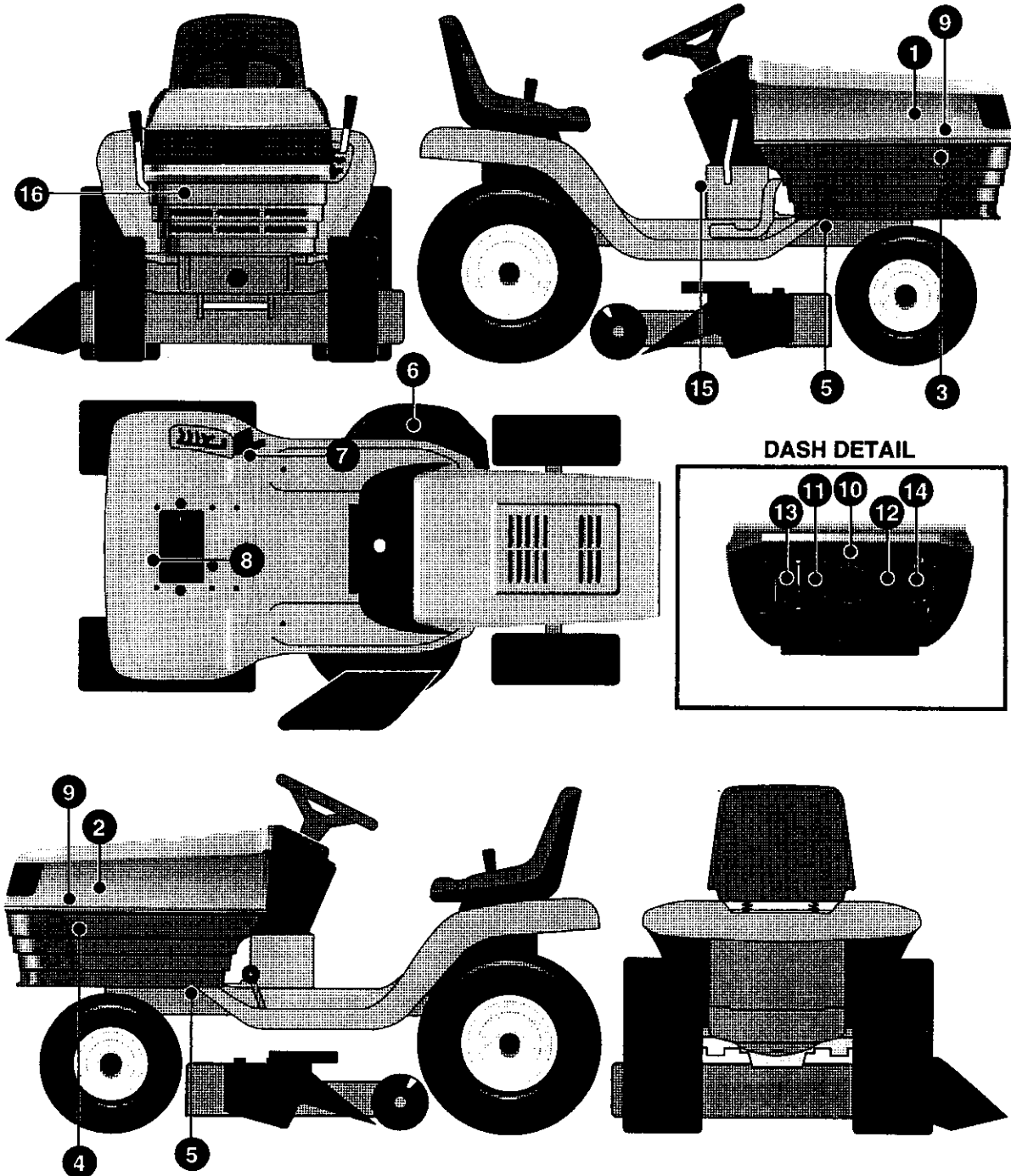

KEY NO.	PART NO.	DESCRIPTION	QTY
1	710506	DECAL, YARDKING RH 20/50"	1
2	710507	DECAL, YARDKING LH 20/50"	1
3	710514	DECAL, PEDAL CTRL RH AUTODRIVE	1
4	710513	DECAL, PEDAL CTRL LH AUTODRIVE	1
5	710511	DECAL, TWIN DURA-BEAM FRAME	2
6	710510	DECAL, ALL PERF. DECK 44X6700	1
7	710637	DECAL, PERF. CUT LEVELING SYS.	1
8		NOT A SERVICEABLE PART	
9	710238	DECAL, LH RH HOOD	2
10	710712	DECAL, CUST. CARE Y.K. PERF.	1
11	302049	DECAL, DASH LH	1
12	711948	DECAL, DASH CE SYMBOLS	1
13	305767	DECAL, DASH LH	1
14	710765	DECAL, DASH RH IG, SW, PTO	1
15	307820	DECAL, PARK BRAKE	1
16	712039	DECAL, GRILLE CAST IRON	1

343708A

NOTES

LAWN TRACTOR ACCESSORIES

Make your Lawn Tractor do more than you ever imagined.

The accessories shown on this page can be used on your Lawn Tractor. See the Store or Dealer where you purchased your Lawn Tractor. If you are unable to obtain the necessary information, contact the Central Parts Distribution Center for your area as listed in your Repair Parts Book.

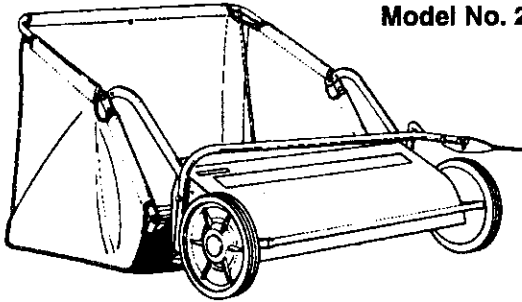

LAWN SWEEPER
Model No. 24720

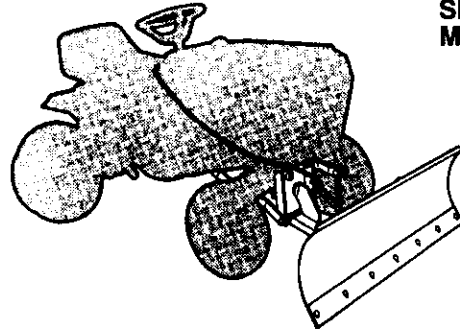

SNOW BLADE
Model No. 24476

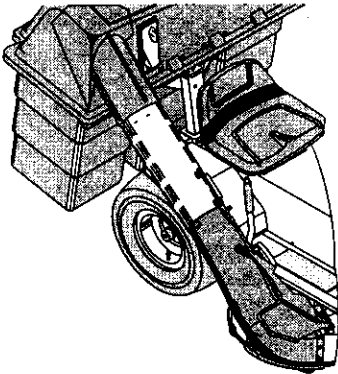

GRASS BAGGER
Model No. 24762
9 Bushel Capacity
(For 42" and 46")

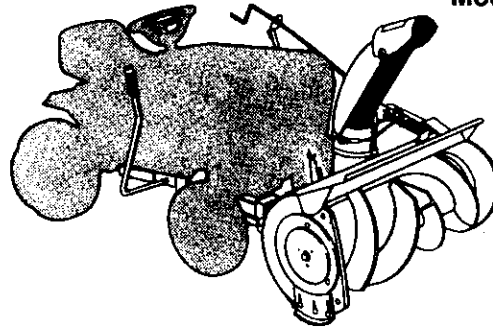

SNOW THROWER
Model No. 24574

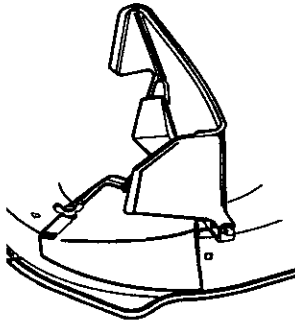

38" MULCHER KIT
Model No. 24750
40" MULCHER KIT
Model No. 24755
42" MULCHER KIT
Model No. 24758

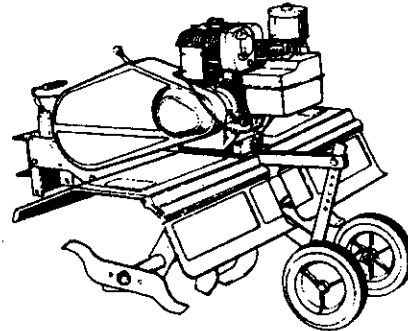

GARDEN TILLER
Model No. 13460

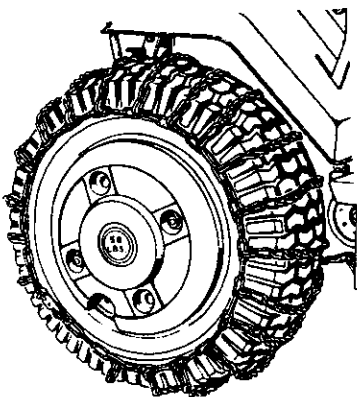

TIRE CHAINS
Model No. 24530
(For 18x8.5 inch tire)
Model No. 24538
(For 18x9.5 inch tires)
Model No. 24525
(For 20x8 inch tire)
Model No. 24515
(For 20x10 inch tire)
Model No. 24539
(For 23x9.5 inch tire)

REAR WHEEL WEIGHTS
Model No. 24003
(For 18x9.5 inch tires)
(For 20x8 inch tires)
Model No. 24630
(For 23 inch tires)

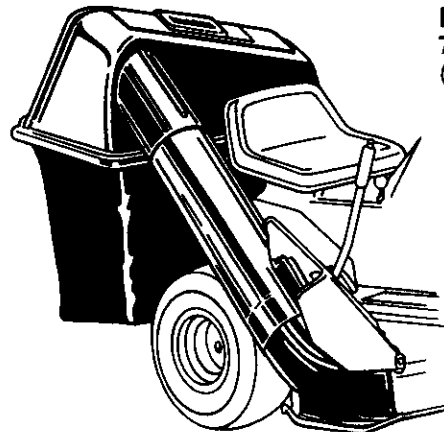

GRASS BAGGER
Model No. 24742
7 Bushel Capacity
(For 38", 40", and 42")

Made in U.S.A.

HOW TO ORDER REPAIR PARTS

Only use a factory repair part. Repair parts, except for the engine or the transmission, are available from the store where the unit was purchased, a service shop recommended by the store, or an authorized service shop found in the yellow pages of the telephone directory. If you cannot get a repair part or service as described above, call or write to the Central Parts Distributor shown below. When you order, include the following information: (1) Complete Model Number (see nameplate), (2) Date of Manufacture, (3) Complete Part Number, (4) Description, (5) Quantity.

Repair parts for the engine or the transmission are available from the manufacturer's authorized service center found in the yellow pages of the telephone directory. See the individual engine or transmission warranties.

LAWN MOWER CENTRAL PARTS DISTRIBUTORS

BEBCO, INC.

2221 2nd. Ave. South
Birmingham, AL 35233
(205) 251-4600
1-800-828-8094

Alabama, Florida, Georgia, Puerto Rico

BILLIOU'S, INC.

1343 South Main St.
Porterville, CA. 93257
(209) 784-4102
1-800-245-5468
FAX 1-800-226-7337

Arizona, California, Hawaii, Nevada

BROWN & WISER, INC.

9991 S.W. Avery Street
P.O. Box 1109
Tualatin, OR. 97062
(503) 692-0330
1-800-882-4782

Alaska, Idaho (counties Ada, Adams, Benewah, Boise, Bonner, Boudry, Canyon, Clearwater, Elmore, Gem, Idaho, Kooten, Latah, Lewis, Nez Perce, Owyee, Payette, Ravalli, Shoshone, Valley, Washington), *Montana* (counties Flathead, Lake, Lincoln, Mineral, Missoulo, Ravalli, Sanders), *Oregon, Washington*

CANADA POWER TECHNOLOGY

161 Watline Avenue
Mississauga, Ont. L4Z-1P2
(905) 890-6900
1-800-861-9559 (Ontario Only)

Canada

CHILTON AIR COOLED ENGINE

319 4th. Ave. South
P.O. Box 150806
Nashville, TN. 37215
(615) 254-1634 1-800-621-6934

Arkansas (counties Clay, Craighead, Crittendan, Cross, Greene, Jackson, Lawrence, Lee, Mississippi, Monroe, Phillips, Poinsett, Randolph, St. Francis, Woodruff), *Mississippi* (counties Desota, Panola, Quitman, Tate, Tunica), *Missouri* (counties Dunkin, New Madrid, Pemiscot), *Tennessee, Virginia* (counties Bland, Buchanan, Dickenson, Lee, Russell, Scott, Smyth, Tazewell, Washington, Wise)

712008

ENGINES SOUTHWEST

1255 No Hearne
Shreveport, LA. 71107-7108
(318) 222-3871
1-800-388-6995

Arkansas (except these counties: Clay, Craighead, Crittendan, Cross, Greene, Hempstead, Howard, Jackson, Lafayette, Lawrence, Lee, Little River, Miller, Mississippi, Monroe, Nevada, Phillips, Pike, Poinsett, Randolph, Sevier, St. Francis, Woodruff) *Louisiana, Mississippi* (except these counties: Desota, Panola, Quitman Tate, Tunica,)

FRANK EDWARDS CO.

3653 South 500 West
Salt Lake City, UT 84101
(801) 281-4660
1-800-366-4563

Colorado, Idaho (counties Bannock Bearlake, Bingham, Blaine, Booneville, Butte, Camas, Caribou, Cassia, Custer, Franklin, Fremont, Gooding, Jefferson, Jerome, Lemhi, Lincoln, Madison, Minidoka, Oneida, Power, Teton, Twin Falls) *Montana* (all counties except Flathead, Lake, Lincoln, Mineral, Missoulo, Ravalli, and Sanders), *Utah, Wyoming*

GARDNER, INC.

1150 Chesapeake Ave.
Columbus, OH. 43212
(614) 488-7951
1-800-848-8946

Indiana, Kentucky, Michigan (except upper Peninsula), *Ohio, Western Pennsylvania* with zip codes up to and including 16999, *West Virginia*

GULF COAST ENGINE, INC.

4202 Russell Dr.
P.O. Box 9724
Corpus Christi, TX. 78408
(512) 888-6999
1-800-825-6999

Arkansas (counties Hempstead, Howard, Lafayette, Little River, Miller, Nevada, Pike, Sevier) *New Mexico, Oklahoma, Texas, Mexico*

OSCAR WILSON ENGINE & PARTS

826 Lone Star Dr.
O'Fallon, MO. 63366
(314) 978-1313
1-800-873-6722

Illinois (S. of Hwy. 80), *Iowa, Kansas, Missouri* (all counties except Dunkin, New Madrid, Pemiscot) *Nebraska*

R.B.I. CORPORATION

P.O. Box 9318
Richmond, VA. 23227
(804) 550-2210
1-800-888-7149

Connecticut, Delaware, District of Columbia, Maine, Maryland, Massachusetts, New Hampshire, New Jersey, New York, N. & S. Carolina, Pennsylvania zips 17000 & up, *Rhode Island, Vermont, Virginia* (all counties except Bland, Buchanan, Dickenson, Lee, Russell, Scott, Smyth, Tazewell, Washington, Wise)

WISCONSIN MAGNETO (2 LOCATIONS)

4727 N. Teutonia Ave.
P.O. Box 9218
Milwaukee, WI. 53209
(414) 445-2800
1-800-733-7388

Illinois (N. of Hwy. 80), *Michigan* (upper Peninsula), *Wisconsin*

800 McKinley St.
Anoka, MN. 55303
(612) 323-7477
1-800-248-4016

Minnesota, North & South Dakota