



Operator's Manual



**2-Cycle Gasoline
Trimmer / Edger**

Model TB25ET

IMPORTANT: READ SAFETY RULES AND INSTRUCTIONS CAREFULLY

P/N 769-00551 (12/02)
PRINTED IN USA

TABLE OF CONTENTS

Content	Page
Calling Customer Support	2
Rules for Safe Operation	3
Know Your Unit	6
Assembly Instructions	7
Oil and Fuel Information	8
Starting/Stopping Instructions	9
Operating Instructions	10
Maintenance and Repair Instructions	13
Cleaning and Storage	20
Accessories and Replacement Parts	20
Troubleshooting Chart	21
Specifications	22
Warranty Information	24
Parts List	Inside Back Cover

NOTE: For users on U.S. Forest Land and in the states of California, Maine, Oregon and Washington. All U.S. Forest Land and the state of California (Public Resources Codes 4442 and 4443), Oregon and Washington require, by law that certain internal combustion engines operated on forest brush and/or grass-covered areas be equipped with a spark arrestor, maintained in effective working order, or the engine be constructed, equipped and maintained for the prevention of fire. Check with your state or local authorities for regulations pertaining to these requirements. Failure to follow these requirements could subject you to liability or a fine. **This unit is factory equipped with a spark arrestor.** If it requires replacement, **Accessory Part #182747 Spark Arrestor Screen is available by contacting the service department.**

FINDING MODEL NUMBER

This operator's manual is an important part of your new trimmer. It will help you assemble, prepare and maintain the unit for best performance. Please read and understand what it says.

Before you start assembling your new equipment, please locate the model plate on the equipment and copy the information from it in the space provided below. This information is very important if you need help from our Customer Support Department or an authorized dealer.

<p>Serial Number Model Number</p> <p>Parent Part Number</p>	<p>Copy the model and parent part number here: _____</p> <p>Copy the serial number here: _____</p>
---	--

CALLING CUSTOMER SUPPORT

If you have difficulty assembling this product or have any questions regarding the controls, operation or maintenance of this unit, please call the Customer Support Department.



Call **1-800-520-5520** to reach a Customer Support representative. Please have your unit's model number and serial number ready when you call. See the previous section to locate this information. You will be asked to enter the serial number in order to process your call.

For more details about your unit, visit our website at www.troybilt.com

RULES FOR SAFE OPERATION

The purpose of safety symbols is to attract your attention to possible dangers. The safety symbols, and their explanations, deserve your careful attention and understanding. The safety warnings do not by themselves eliminate any danger. The instructions or warnings they give are not substitutes for proper accident prevention measures.



SYMBOL MEANING



SAFETY ALERT SYMBOL: Indicates danger, warning or caution. Attention is required in order to avoid serious personal injury. May be used in conjunction with other symbols or pictographs.

NOTE: Advises you of information or instructions vital to the operation or maintenance of the equipment.

California Proposition 65 Warning:

	WARNING	
<p>THE ENGINE EXHAUST FROM THIS PRODUCT CONTAINS CHEMICALS KNOWN TO THE STATE OF CALIFORNIA TO CAUSE CANCER, BIRTH DEFECTS OR OTHER REPRODUCTIVE HARM.</p>		

READ ALL INSTRUCTIONS BEFORE OPERATING

- Read the instructions carefully. Be familiar with the controls and proper use of the unit.
- Do not operate this unit when tired, ill or under the influence of alcohol, drugs or medication.
- Children and teens under the age of 15 must not use the unit, except for teens guided by an adult.
- Inspect the unit before use. Replace damaged parts. Check for fuel leaks. Make sure all fasteners are in place and secure. Replace cutting attachment parts that are cracked, chipped or damaged in any way. Make sure the cutting attachment is properly installed and securely fastened. Be sure the cutting attachment shield is properly attached, and positioned as recommended. Failure to do so can result in personal injury to the operator and bystanders, as well as damage to the unit.
- Use only 0.095 inch (2.41 mm) diameter Genuine Factory Parts™ replacement line. Never use metal-reinforced line, wire or rope. These can break off and become dangerous projectiles.
- Be aware of the risk of injury to the head, hands and feet.

SYMBOL MEANING



DANGER: Failure to obey a safety warning will result in serious injury to yourself or to others. Always follow the safety precautions to reduce the risk of fire, electric shock and personal injury.



WARNING: Failure to obey a safety warning can result in injury to yourself and others. Always follow the safety precautions to reduce the risk of fire, electric shock and personal injury.



CAUTION: Failure to obey a safety warning may result in property damage or personal injury to yourself or to others. Always follow the safety precautions to reduce the risk of fire, electric shock and personal injury.

- Clear the area to be cut before each use. Remove all objects such as rocks, broken glass, nails, wire or string. They can be thrown or become entangled in the cutting attachment. Clear the area of children, bystanders, and pets. At a minimum, keep all children, bystanders and pets outside a 50-foot (15 m.) radius; there still may be a risk to bystanders from thrown objects. Bystanders should be encouraged to wear eye protection. If you are approached, stop the engine and cutting attachment immediately.
- Squeeze the throttle control and check that it returns automatically to the idle position. Make all adjustments or repairs before using unit.
- This unit was not designed to be used as a brushcutter. Do not attach or operate this unit with any type of brushcutting blade or brushcutting attachment.

SAFETY WARNINGS FOR GAS TRIMMERS



WARNING: Gasoline is highly flammable, and its vapors can explode if ignited. Take the following precautions:

- Store fuel only in containers specifically designed and approved for the storage of such materials.
- Always stop the engine and allow it to cool before filling the fuel tank. Never remove the cap of the fuel tank, or add fuel, when the engine is hot. Never operate the unit without the fuel cap securely in place. Loosen the fuel tank cap slowly to relieve any pressure in the tank.
- Add fuel in a clean, well-ventilated outdoor area where there are no sparks or flames. Slowly remove the fuel cap only after stopping engine. Do not smoke while fueling or mixing fuel. Wipe up any spilled fuel from the unit immediately.
- Avoid creating a source of ignition for spilled fuel. Do not start the engine until fuel vapors dissipate.
- Move the unit at least 30 feet (9.1 m) from the fueling source and site before starting the engine. Do not smoke. Keep sparks and open flames away from the area while adding fuel or operating the unit.

RULES FOR SAFE OPERATION

WHILE OPERATING

- Never start or run the unit inside a closed room or building. Breathing exhaust fumes can kill. Operate this unit only in a well ventilated outdoor area.
- Wear safety glasses or goggles that are marked as meeting ANSI Z87.1-1989 standards. Also wear ear/hearing protection when operating this unit. Wear a face or dust mask if the operation is dusty. Long sleeve shirts are recommended.
- Wear heavy, long pants, boots and gloves. Do not wear loose clothing, jewelry, short pants, sandals or go barefoot. Secure hair above shoulder level.
- The cutting attachment shield must always be in place while operating the unit. Do not operate unit without both trimming lines extended, and the proper line installed. Do not extend the trimming line beyond the length of the shield.
- This unit has a clutch. The cutting attachment remains stationary when the engine is idling. If it does not, have the unit adjusted by an authorized service technician.
- Adjust the J-handle to your size to provide the best grip.
- Be sure the cutting attachment is not in contact with anything before starting the unit.
- Use the unit only in daylight or good artificial light.
- Avoid accidental starting. Be in the starting position whenever pulling the starter rope. The operator and unit must be in a stable position while starting. See *Starting/Stopping Instructions*.
- Use the right tool. Only use this tool for the purpose intended.
- Do not overreach. Always keep proper footing and balance.
- Always hold the unit with both hands when operating. Keep a firm grip on both the front and rear handle or grips.
- Keep hands, face, and feet at a distance from all moving parts. Do not touch or try to stop the cutting attachment when it is rotating.
- Do not touch the engine or muffler. These parts get extremely hot from operation. They remain hot for a short time after you turn off the unit.
- Do not operate the engine faster than the speed needed to cut, trim or edge. Do not run the engine at high speed when you are not cutting.
- Always stop the engine when cutting is delayed or when walking from one cutting location to another.
- If you strike or become entangled with a foreign object, stop the engine immediately and check for damage. Do not operate before repairing damage. Do not operate the unit with loose or damaged parts.
- Stop and switch the engine to off for maintenance, repair, or for changing the cutting attachment or other attachments.

Use only Genuine Factory Parts™ replacement parts and accessories for this unit. These are available from your authorized service dealer. Use of any unauthorized parts or accessories could lead to serious injury to the user, or damage to the unit, and void your warranty.

- Keep unit clean of vegetation and other materials. They may become lodged between the cutting attachment and shield.
- To reduce fire hazard, replace faulty muffler and spark arrestor, keep the engine and muffler free from grass, leaves, excessive grease or carbon build up.

WHILE OPERATING WITH EDGER

- Inspect the unit before use. Ensure the blade is installed correctly and secure.
- Clear the area to be edged before each use. Remove all objects such as rocks, broken glass, nails, wire, or string which can be thrown or become entangled in the edging attachment.
- Do not attempt to touch or stop the blade when it is rotating.
- A coasting blade can cause injury while it continues to spin after the engine is stopped or the throttle control is released. Maintain proper control until the blade has completely stopped rotating.
- Do not run the unit at high speed when not edging.
- If you strike or become entangled with a foreign object, stop the engine immediately and check for damage. Have any damage repaired before attempting further operations. Do not operate unit with a bent, cracked or dull blade. Discard blades that are bent, warped, cracked or broken.
- Stop the engine IMMEDIATELY if you feel excessive vibration. Vibration is a sign of trouble. Inspect thoroughly for loose nuts, bolts or damage before continuing. Repair or replace affected parts as necessary.

OTHER SAFETY WARNINGS

- Never store the unit, with fuel in the tank, inside a building where fumes may reach an open flame or spark.
- Allow the engine to cool before storing or transporting. Be sure to secure the unit while transporting.
- Store the unit in a dry area, locked up or up high to prevent unauthorized use or damage, out of the reach of children.
- Never douse or squirt the unit with water or any other liquid. Keep handles dry, clean and free from debris. Clean after each use. See the *Cleaning and Storage* instructions.
- Keep these instructions. Refer to them often and use them to instruct other users. If you loan someone this unit, also loan them these instructions.

SAVE THESE INSTRUCTIONS

RULES FOR SAFE OPERATION

SAFETY AND INTERNATIONAL SYMBOLS

This operator's manual describes safety and international symbols and pictographs that may appear on this product. Read the operator's manual for complete safety, assembly, operating and maintenance and repair information.

SYMBOL



MEANING

- **SAFETY ALERT SYMBOL**

Indicates danger, warning, or caution. May be used in conjunction with other symbols or pictographs.



- **WARNING - READ OPERATOR'S MANUAL**

Read the Operator's Manual(s) and follow all warnings and safety instructions. Failure to do so can result in serious injury to the operator and/or bystanders.



- **WEAR EYE AND HEARING PROTECTION**

WARNING: Thrown objects and loud noise can cause severe eye injury and hearing loss. Wear eye protection meeting ANSI Z87.1-1989 standards and ear protection when operating this unit. Use a full face shield when needed.



- **KEEP BYSTANDERS AWAY**

WARNING: Keep all bystanders, especially children and pets, at least 50 feet (15 m.) from the operating area.



- **UNLEADED FUEL**

Always use clean, fresh unleaded fuel.



- **OIL**

Refer to operator's manual for the proper type of oil.

SYMBOL



MEANING

- **THROWN OBJECTS AND ROTATING CUTTER CAN CAUSE SEVERE INJURY**

WARNING: Do not operate without the cutting attachment shield in place. Keep away from the rotating cutting attachment.



- **ON/OFF STOP CONTROL**

ON / START / RUN



- **ON/OFF STOP CONTROL**

OFF OR STOP



- **HOT SURFACE WARNING**

Do not touch a hot muffler or cylinder. You may get burned. These parts get extremely hot from operation. When turned off they remain hot for a short time.



- **SHARP BLADE**

WARNING: Sharp blade on cutting attachment shield. To prevent serious injury, do not touch line cutting blade.

RULES FOR SAFE OPERATION

KNOW YOUR UNIT

APPLICATIONS

As a trimmer:

- Cutting grass and light weeds.
- Decorative trimming around trees, fences, etc.

With Edger Add-On:

- Edging along paths, driveways, rockeries, etc.

Other optional accessories may be used with the TB25ET. Refer to *Operating the EZ-Link System* for a list of add-ons.

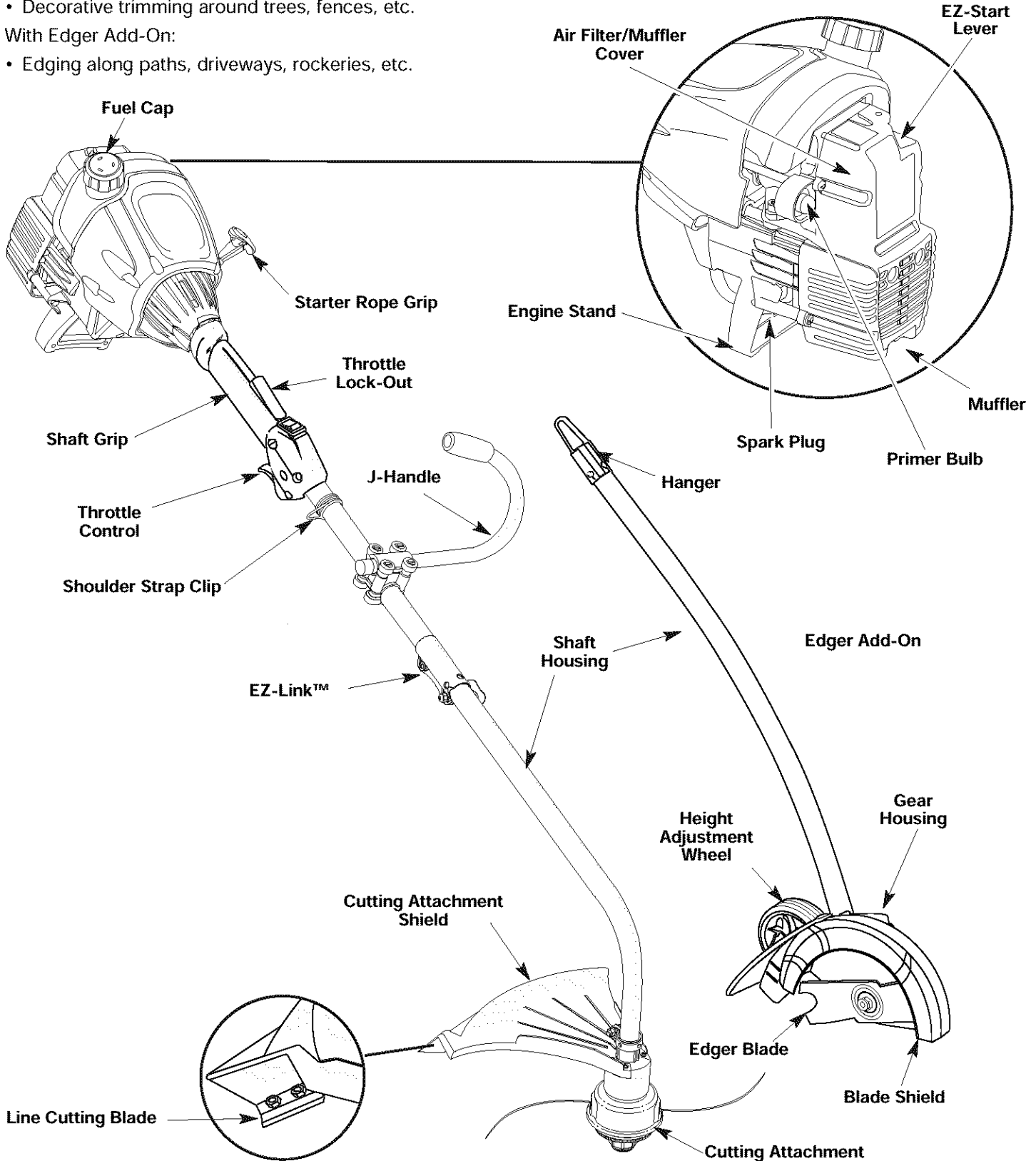

ASSEMBLY INSTRUCTIONS

On some units, the J-handle may be pre-installed. In this case you must loosen screws and adjust the handle to fit the operator. Go to step 5 if the J-handle is pre-installed.

INSTALL AND ADJUST THE J-HANDLE

1. Place the J-handle between the top and middle clamp pieces (Fig. 1).

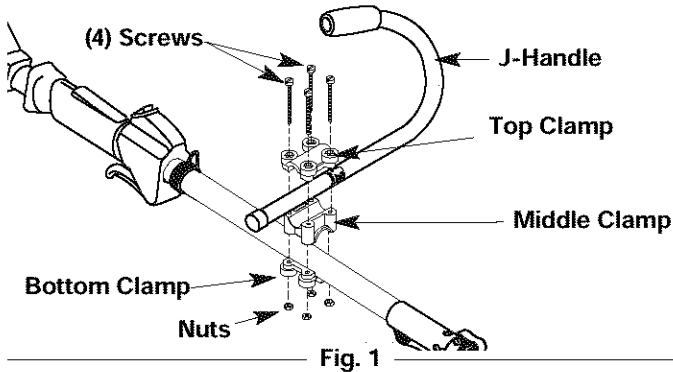

2. While holding the three pieces together, install the four (4) screws through the top clamp and into middle clamp.

NOTE: The holes in the top and middle clamp will line up only when assembled correctly.

3. Place the clamps and the J-handle over the shaft housing and onto the bottom clamp.
4. Hold each hex nut in the bottom clamp recess with a finger. Start screws with a large Phillips screwdriver. Do not tighten until you make the handle adjustment.
5. Slide the J-handle in or out until the arrow/white line on the decal touches the clamp assembly (Fig. 2). You must first loosen the screws if the handle is pre-installed.

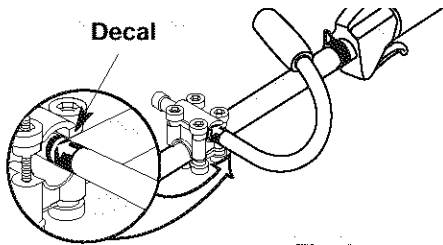

6. While holding the unit in the operating position (Fig. 3), position the J-handle to the location that provides you the best grip.

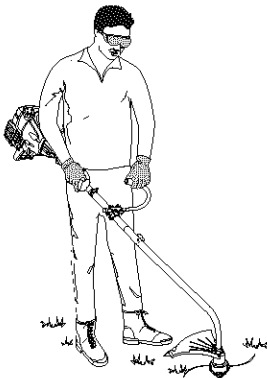

7. Tighten the clamp screws evenly, until the J-handle is secure.

INSTALLING THE CUTTING SHIELD

Use the following instructions if the cutting attachment shield on your unit is not installed or if you ever need to re-install it.

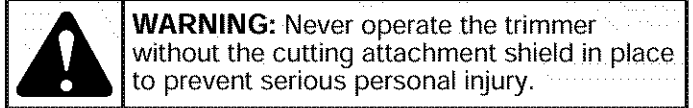

1. Place the cutting attachment shield onto the shaft housing above the clamp assembly (Fig. 4).

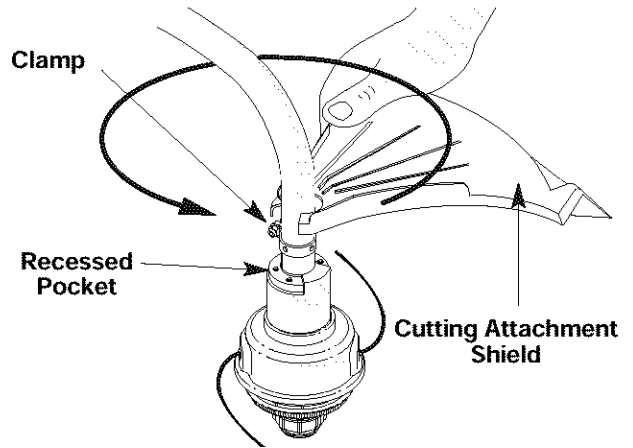

2. Push the cutting attachment shield down to the top of the cutting attachment assembly. Then rotate the shield until its screw holes line up with the holes in the cutting attachment. The shield guard should fit into the recessed pocket (Fig. 4).

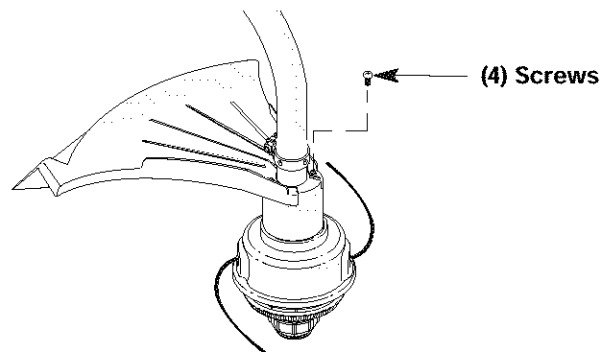

3. Install the screws with a Phillips screwdriver (Fig. 5).

OIL AND FUEL INFORMATION

OIL AND FUEL MIXING INSTRUCTIONS

Old and/or improperly mixed fuel are the main reasons for the unit not running properly. Be sure to use fresh, clean unleaded fuel. Follow the instructions carefully for the proper fuel/oil mixture.

Definition of Blended Fuels

Today's fuels are often a blend of gasoline and oxygenates such as ethanol, methanol, or MTBE (ether). Alcohol-blended fuel absorbs water. As little as 1% water in the fuel can make fuel and oil separate. It forms acids when stored. When using alcohol-blended fuel, use fresh fuel (less than 60 days old).

Using Blended Fuels

If you choose to use a blended fuel, or its use is unavoidable, follow recommended precautions:

- Always use the fresh fuel mix explained in your operator's manual
- Always agitate the fuel mix before fueling the unit
- Drain the tank and run the engine dry before storing the unit



Using Fuel Additives

The bottle of 2-cycle oil that came with your unit contains a fuel additive which will help inhibit corrosion and minimize the formation of gum deposits. It is recommended that you use our 2-cycle oil with this unit. If unavailable, use a good 2-cycle oil designed for air-cooled engines along with a fuel additive, such as STA-BIL® Gas Stabilizer or an equivalent. Add 0.8 oz. (23 ml.) of fuel additive per gallon of fuel according to the instructions on the container. NEVER add fuel additives directly to the unit's fuel tank.

	CAUTION: For proper engine operation and maximum reliability, pay strict attention to the oil and fuel mixing instructions on the 2-cycle oil container. Using improperly mixed fuel can severely damage the engine.
--	---

Thoroughly mix the proper ratio of 2-cycle engine oil with unleaded gasoline in a separate fuel can. Use a 40:1 fuel/oil ratio. Do not mix them directly in the engine fuel tank. See the table below for specific gas and oil mixing ratios.

NOTE: One gallon (3.8 liters) of unleaded gasoline mixed with one 3.2 oz. (95 ml.) bottle of 2-cycle oil makes a 40:1 fuel/oil ratio.

	+	
UNLEADED GAS		2 CYCLE OIL
1 US. GALLON	+	3.2 FL. OZ.
(3.8 LITERS)		(95 ml)
1 LITER + 25 ml		
MIXING RATIO - 40:1		

	WARNING: Gasoline is extremely flammable. Ignited Vapors may explode. Always stop the engine and allow it to cool before filling the fuel tank. Do not smoke while filling the tank. Keep sparks and open flames at a distance from the area.
---	--

	WARNING: Remove fuel cap slowly to avoid injury from fuel spray. Never operate the unit without the fuel cap securely in place.
---	--

	WARNING: Add fuel in a clean, well ventilated area outdoors. Wipe up any spilled fuel immediately. Avoid creating a source of ignition for spilt fuel. Do not start the engine until fuel vapors dissipate.
---	--

NOTE: Dispose of the old fuel/oil mix in accordance to Federal, State and Local regulations.

STARTING/STOPPING INSTRUCTIONS



WARNING: Operate this unit only in a well-ventilated outdoor area. Carbon monoxide exhaust fumes can be lethal in a confined area.



WARNING: Avoid accidental starting. Make sure you are in the starting position when pulling the starter rope (Fig. 8). To avoid serious injury, the operator and unit must be in a stable position while starting.

Make sure that any Add-On is installed correctly and secure before starting the unit.

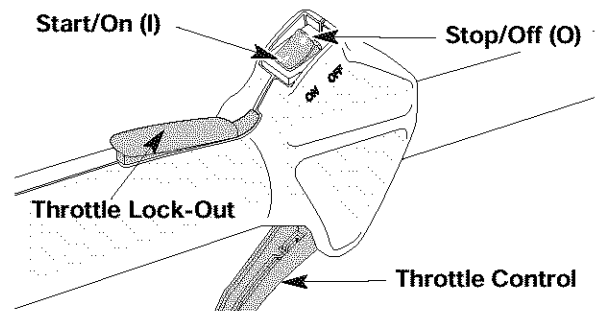

Fig. 6

STARTING INSTRUCTIONS

IF... You are starting a warm engine, begin at step 4.

1. Mix gas with oil. Fill fuel tank with fuel/oil mixture. See *Oil and Fuel Mixing Instructions*.
2. Make sure the On/Off Stop Control is in the **ON (I)** position (Fig. 6).
3. Fully press and release the primer bulb 10 times, slowly, until **FUEL IS VISIBLE IN THE PRIMER BULB** (Fig. 7). If you can't see fuel in the bulb, press and release the bulb as many times as it takes before you can see fuel in it.
4. Push the EZ-Start™ Lever to the left until it clicks and locks into place (Fig. 7).
5. With the unit in the starting position, **DO NOT SQUEEZE THE THROTTLE CONTROL** (Fig. 8). Pull the starter rope 5 times briskly, making sure the EZ-Start™ lever is pushed to the left.

IF... The engine does not start, go back to step 3.

IF... The engine starts to run before the fifth pull, go to step 6.

IF... The outside temperature or engine temperature exceeds 90° F and the engine fails to start after 5 pulls, fully squeeze the throttle control and pull the starter rope briskly 3 to 8 more times. The engine should start within these pulls.

NOTE: When starting, the EZ-Start™ Lever will automatically click off when you squeeze the throttle control.

6. When the engine starts, squeeze the throttle control to warm up the engine for 5 to 10 seconds. The EZ-Start™ Lever will click off automatically (Fig. 7).

IF... The engine stalls while squeezing the throttle, go back to step 4.

IF... The engine stalls before you squeeze the throttle control, hold the throttle control and pull the starter rope until the trimmer starts.

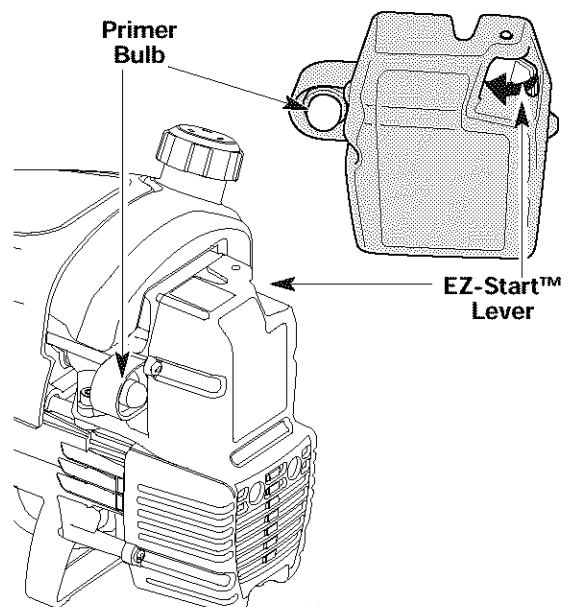

Fig. 7

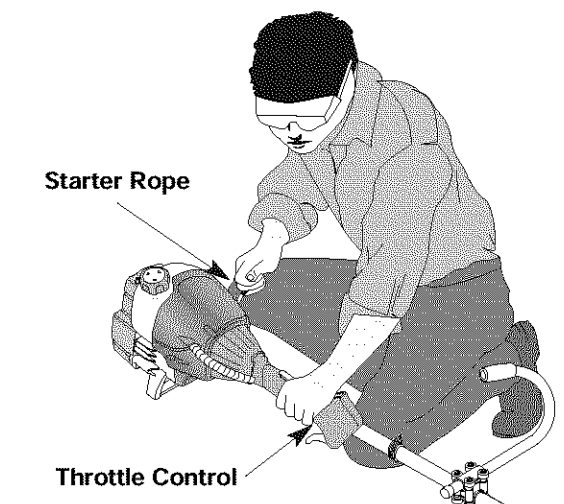

Fig. 8

STOPPING INSTRUCTIONS

1. Release your hand from the throttle control (Fig. 8). Allow the engine to cool down by idling.
2. Put the On/Off Stop Control in the **OFF (O)** position (Fig. 6).

OPERATING INSTRUCTIONS

OPERATING THE EZ-LINK™ SYSTEM

The EZ-Link™ system enables the use of these optional Add-Ons.

Blower/Vacuum	TBBV
Cultivator	TBGC
Edger	TBLE
Hedge Trimmer	TBHS
Snow Thrower	TBST
Straight Shaft Trimmer	TBSS
Tree Pruner	TBTP
Turbo Blower	TBTB



WARNING: Read and understand the operator's manual for each add-on prior to operation.

Removing the Cutting Attachment or Add-Ons

1. Turn the knob counterclockwise to loosen (Fig. 9).
2. Press and hold the release button (Fig. 9).
3. While firmly holding the upper shaft housing, pull the cutting attachment or add-on straight out of the EZ-Link™ coupler (Fig. 10).



WARNING: To avoid serious personal injury and damage to the unit, shut unit off before removing or installing add-ons.

Installing the Cutting Attachment or Add-Ons

NOTE: To make installing or removing the add-on easier, place the unit on the ground or on a work bench.

1. Turn knob counterclockwise to loosen (Fig. 9).

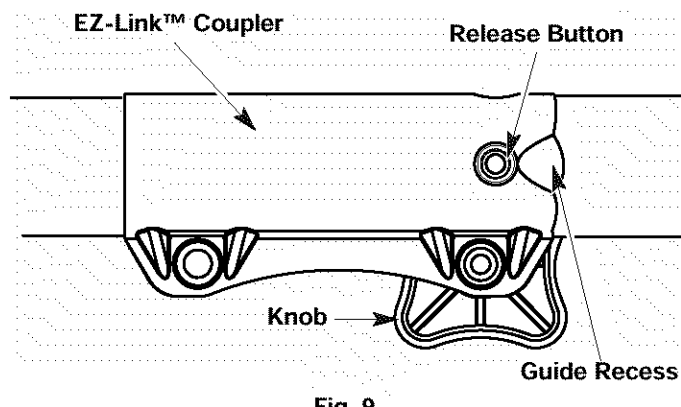

Fig. 9

2. While firmly holding the add-on, push it straight into the EZ-Link™ coupler (Fig. 10).

NOTE: Aligning the release button with the guide recess will help installation (Fig. 9).

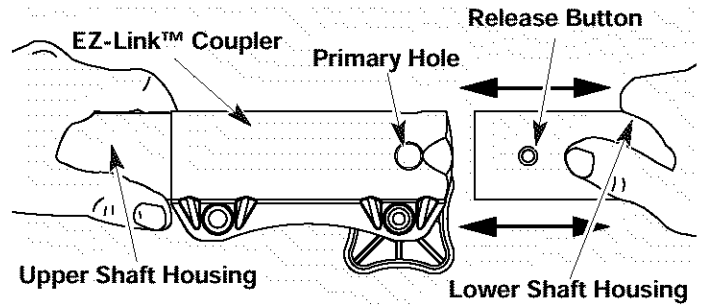



Fig. 10

3. Turn the knob clockwise to tighten (Fig. 11).



CAUTION: Lock the release button in the primary hole and securely tighten the knob before operating this unit.

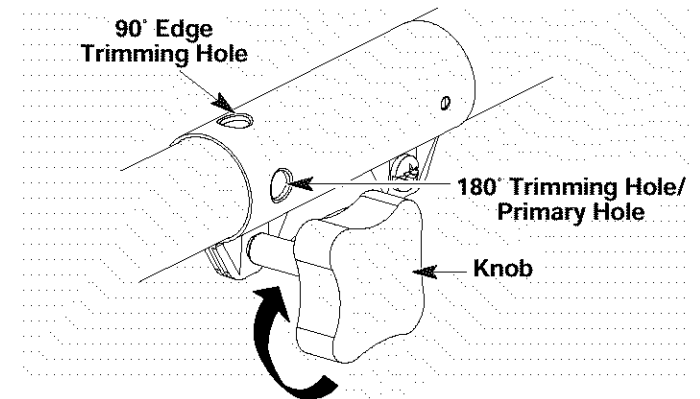



Fig. 11



CAUTION: The cutting attachment and EZ-Link™ add-ons are to be used in the primary hole unless stated otherwise in the specific add-on operator's manual. Using the wrong hole could lead to personal injury, or damage to the unit.

For decorative trimming/edging with the **line head cutting attachment**, lock the release button of the cutting attachment into the 90° hole or the 180° hole (Fig. 11).

For edging with the **edger add-on**, lock the release button of the cutting attachment **only** into the 180° trimming hole/ primary hole (Fig. 11).

OPERATING INSTRUCTIONS

HOLDING THE TRIMMER



WARNING: Always wear eye, hearing, foot and body protection to reduce the risk of injury when operating this unit.

Before operating the unit, stand in the operating position (Fig. 12). Check for the following:

- The operator is wearing eye protection and proper clothing
- With a slightly-bent right arm, the operator's hand is holding the shaft grip
- The operator's left arm is straight, the left hand holding the J-handle
- The unit is at waist level
- The cutting attachment is parallel to the ground and easily contacts the grass without the need to bend over

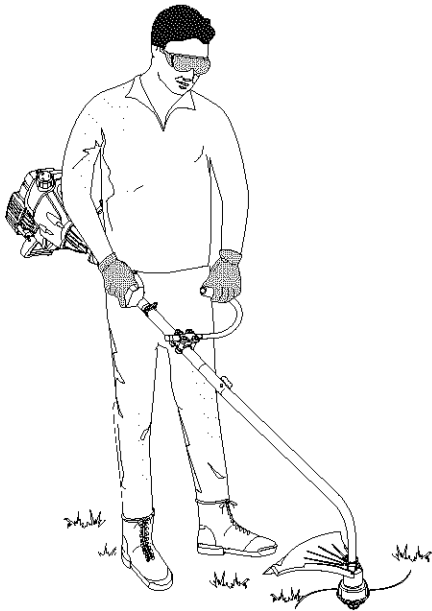

Fig. 12

ADJUSTING TRIMMING LINE LENGTH

The Bump Head™ cutting attachment allows you to release trimming line without stopping the engine. To release more line, lightly tap the cutting attachment on the ground (Fig. 13) while operating the trimmer at high speed.

NOTE: Always keep the trimming line fully extended. Line release becomes more difficult when the cutting line gets shorter.

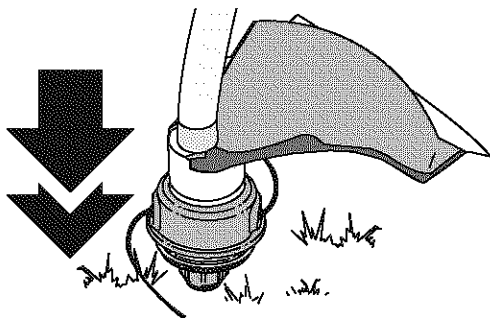

Fig. 13

Each time the head is bumped, about 1 inch (25.4 mm) of trimming line releases. A blade in the cutting attachment shield will cut the line to the proper length if any excess line is released.

For best results, tap the bump knob on bare ground or hard soil. If you attempt a line release in tall grass, the engine may stall. Always keep the trimming line fully extended. Line release becomes more difficult when the cutting line gets shorter.

NOTE: Do not rest the Bump Head™ on the ground while the unit is running.

Some line breakage will occur from:

- Entanglement with foreign matter
- Normal line fatigue
- Attempting to cut thick, stalky weeds
- Forcing the line into objects such as walls or fence posts



CAUTION: Do not remove or alter the line cutting blade assembly. Excessive line length will make the clutch overheat. This may lead to serious personal injury or damage to the unit.

TIPS FOR BEST TRIMMING RESULTS

- Keep the cutting attachment parallel to the ground.
- Do not force the cutting attachment. Allow the tip of the line to do the cutting, especially along walls. Cutting with more than the tip will reduce cutting efficiency and may overload the engine.
- Cut grass over 8 inches (200 mm) by working from top to bottom in small increments to avoid premature line wear or engine drag.
- Cut from right to left whenever possible. Cutting to the left improves the unit's cutting efficiency. Clippings are thrown away from the operator.
- Slowly move the trimmer into and out of the cutting area at the desired height. Move either in a forward-backward or side-to-side motion. Cutting shorter lengths produces the best results.
- Trim only when grass and weeds are dry.
- The life of your cutting line is dependent upon:
 - Following the trimming techniques
 - What vegetation is being cut
 - Where vegetation is cut

For example, the line will wear faster when trimming against a foundation wall as opposed to trimming around a tree.

OPERATING INSTRUCTIONS

DECORATIVE TRIMMING

Decorative trimming is accomplished by removing all vegetation around trees, posts, fences and more.

Rotate the whole unit so that the cutting attachment is at a 30° angle to the ground (Fig. 14).

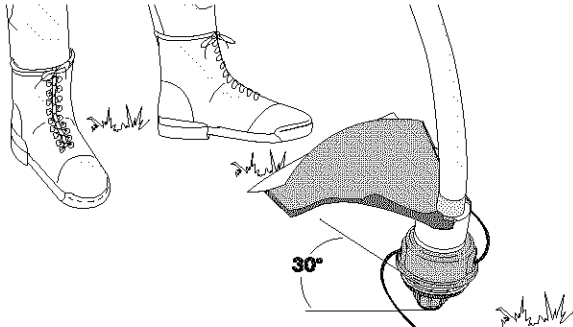
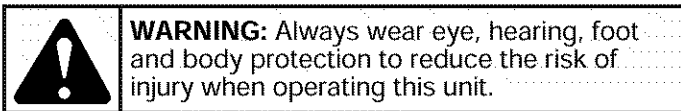

Fig. 14

HOLDING THE UNIT WITH EDGER ADD-ON



WARNING: Always wear eye, hearing, foot and body protection to reduce the risk of injury when operating this unit.

Before operating the unit as an edger, stand in the operating position (Fig. 15). Check for the following:

- The operator is wearing eye protection and proper clothing
- With a slightly-bent right arm, the operator's hand is holding the shaft grip
- The operator's left arm is straight, the left hand holding the J-handle
- The unit is at waist level
- The edger wheel is adjusted for proper cut depth and the edger is positioned as shown in Fig. 15.

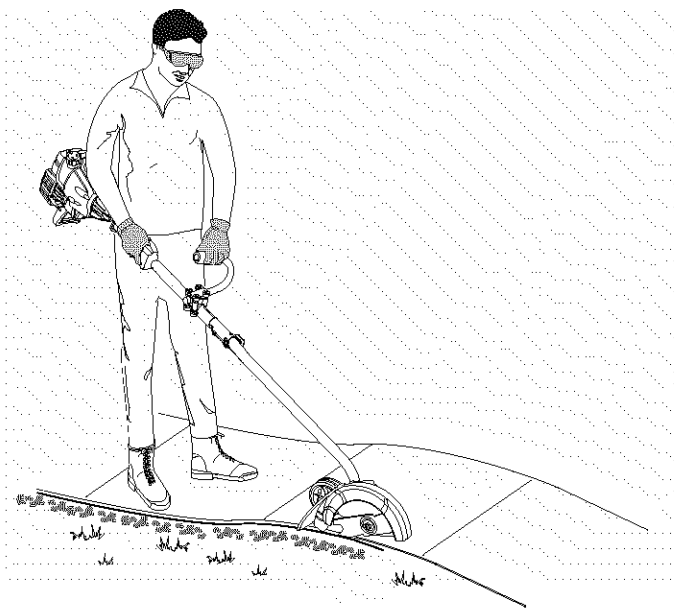

Fig. 15

ADJUSTING EDGER CUTTING DEPTH

1. Loosen the adjustment knob above the wheel (Fig 16).
2. Slide the wheel to the desired position:
 - Raising the wheel increases the cutting depth
 - Lowering the wheel decreases the cutting depth
3. Tighten the adjustment knob securely.

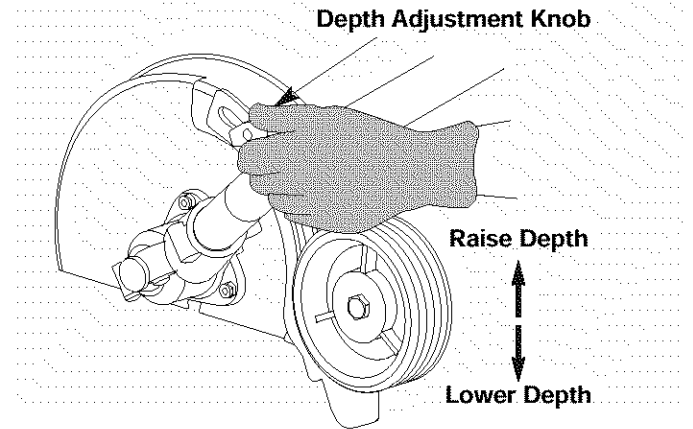

Fig. 16

TIPS FOR BEST EDGING RESULTS

- Keep the cutting attachment perpendicular to the ground.
- Do not force the edger. At first, edge at a lower depth. Then edge the area again with a deeper setting.
- Walk the edger at a slow, even pace
- Check the blade's condition often. As the blade wears, it becomes smaller, reducing the cutting depth performance. Replace with a new blade as required.

HANGER

A plastic hanger (Fig. 17) comes in the hardware pack. Use it to hang up the edger, cutting attachment, or other add-on out of the way when not in use. Push the release button on the shaft housing and pull the hanger to remove. Align the hole in the hanger with the release button on the shaft housing and push on to install.

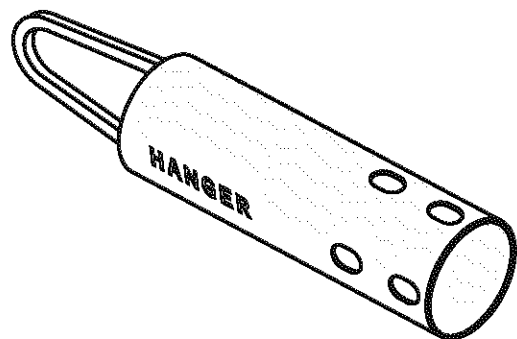



Fig. 17

MAINTENANCE AND REPAIR INSTRUCTIONS

MAINTENANCE SCHEDULE

Perform these required maintenance procedures at the frequency stated in the table. These procedures should also be a part of any seasonal tune-up.

NOTE: Some maintenance procedures may require special tools or skills. If you are unsure about these procedures take your unit to any non-road engine repair establishment, individual or authorized service dealer.



WARNING: To prevent serious injury, never do maintenance or repairs with unit running. Always do maintenance and repairs on a cool unit. Disconnect spark plug wire to ensure the unit will not start.

NOTE: Maintenance, replacement, or repair of the emission control devices and system may be performed by any non-road engine repair establishment, individual or authorized service dealer.

In order to assure peak performance of your engine, inspection of the engine exhaust port may be necessary after 50 hours of operation. If you notice lost RPM, poor performance or general lack of acceleration, this service may be required. If you feel your engine is in need of this inspection, refer service to any non-road engine repair establishment, individual or authorized service dealer for repair. **DO NOT** attempt to perform this process yourself as engine damage may result from contaminants involved in the cleaning process for the port.

FRECUENCIA	MANTENIMIENTO REQUERIDO	CONSULTE
Before starting engine	Fill fuel tank with fresh fuel	Page 8
Every 10 hours	Clean and re-oil air filter	Page 17
Every 25 hours	Check and clean spark arrestor Check spark plug condition and gap	Page 18 Page 20
Every 50 hours	Inspect exhaust port and spark arrestor screen for clogging or obstruction to assure maximum performance levels	Page 18

LINE INSTALLATION FOR THE SPEEDSPOOL®



WARNING: Never use metal-reinforced line, wire, chain, or rope, etc. These can break off and become dangerous projectiles.

Always use Genuine Factory Parts™ 0.095 inch (2.41 mm) replacement line. Lines other than those specified may make the engine overheat or fail.

There are two methods to replace the SpeedSpool® trimming line:

- Wind the inner reel with new line
- Install a pre-wound inner reel

Winding the Inner Reel With New Line

NOTE: It is unnecessary to remove the bump knob to install a new trimming line.

1. Cut two pieces of 0.095 inch (2.41 mm) trimming line, 10 feet (3 m) long.
2. Hold the outer spool and turn the inner reel counterclockwise to line up the arrows on the outer spool and inner reel (Fig. 18).



WARNING: Always use the correct line length when installing trimming line on the unit. The line may not release properly if the line is too long.

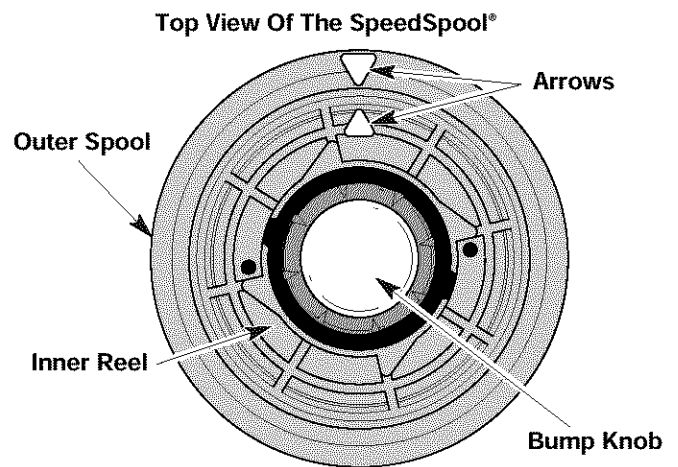

Fig. 18

MAINTENANCE AND REPAIR INSTRUCTIONS

3. Pull old line out of the line loading and line locking holes (Fig. 19 and 20).
4. Insert a piece of trimming line straight into one of the two eyelets in the outer spool. Push it up through the line loading hole in the inner reel (Fig. 19). Do not bend the line when inserting it into the eyelet.

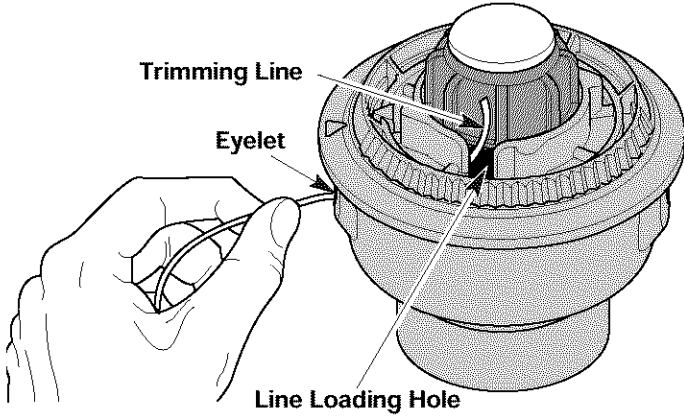

Fig. 19

5. Insert the line into the locking hole (Fig. 20). Do not push the line more than a 1/2 inch (12.7 mm) into the line locking hole. The line will form a small loop (Fig. 20) when it is inserted correctly.

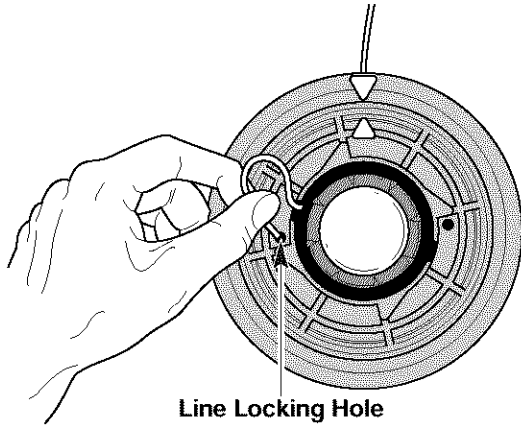

Fig. 20

6. Pull the line from the outer spool until the line is tight against the inner reel (Fig. 21).

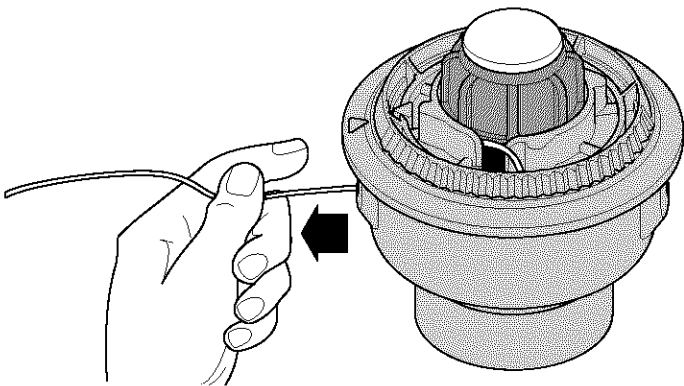

Fig. 21

7. Repeat procedures 4-6 with the second piece of line.
8. Hold the outer spool. Wind the inner reel counterclockwise until approximately four (4) inches (102 mm) of line remain (Fig. 22).

NOTE: Do not wind the inner reel before installing the second piece of line.

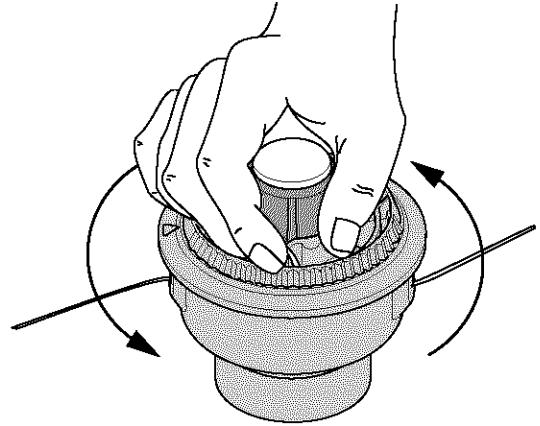

Fig. 22

9. If winding the line becomes difficult or if the line jams, pull the ends of the line from the spool (Fig. 23). Continue winding the inner reel counterclockwise.

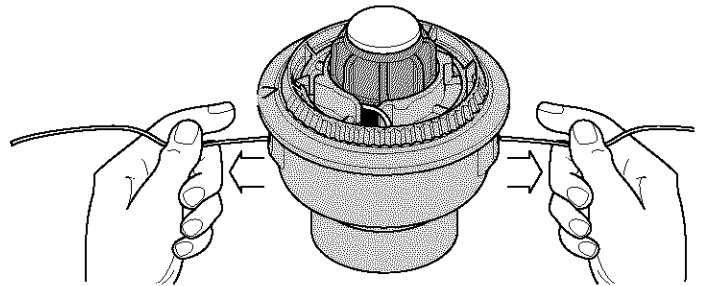

Fig. 23

INSTALLING A PRE-WOUND REEL

1. Turn the bump knob counterclockwise and remove the bump knob, spring and foam seal (Fig. 24).

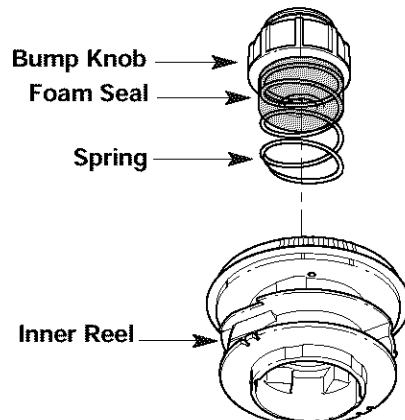

Fig. 24

MAINTENANCE AND REPAIR INSTRUCTIONS

2. Pull the old inner reel with existing line from the outer spool.
3. Insert the ends of the prewound inner reel line into the outer spool eyelets (Fig. 25). Push the new inner reel, arrow side up, into the outer spool.

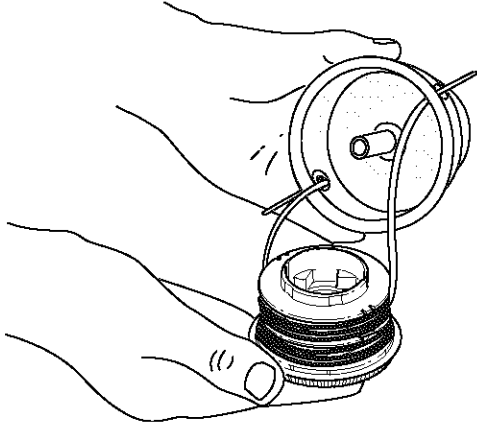

Fig. 25

4. Hold the inner reel in place and install the bump knob, spring and foam seal. Press down and turn the bump knob clockwise. Grasp the ends and pull firmly to release the line from the holding slots in the inner reel (Fig. 23).

Releasing the Inner Reel

If the SpeedSpool® does not release line correctly, pull the ends of the line firmly from the spool (Fig. 23). If this does not release the line, follow the *Cleaning the SpeedSpool®* instructions.

CLEANING THE SPEEDSPOOL®

Cleaning the SpeedSpool® may be necessary if:

- A jammed or excessive line must be removed
- The SpeedSpool® becomes difficult to wind or does not operate correctly when bumping the head on the ground

1. Hold the outer spool, and unscrew the bump knob counterclockwise (Fig. 26).
2. Pull out the bump knob, spring and foam seal (Fig. 24).

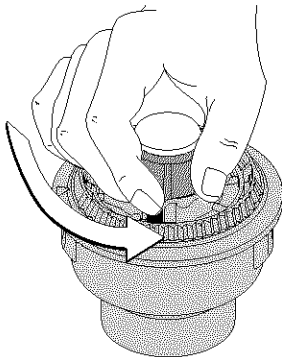

Fig. 26

3. Pull the inner reel with existing line from the outer spool.

4. Remove any existing line from the inner reel before cleaning. Remove any debris or grass from the knob, spring, inner reel and foam seal. Wash the inner reel with warm soapy water (Fig. 27).

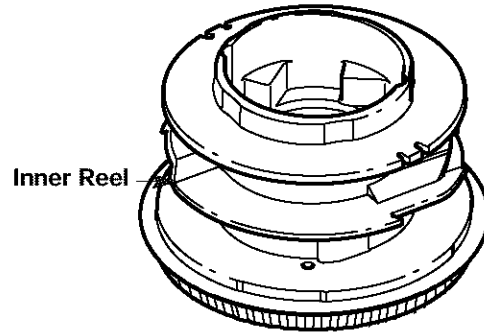

Fig. 27

5. Clean the shaft and the inner surface of the outer spool. To clean the shaft underneath the plunger, press down on the plunger (Fig. 28). Remove any dirt or debris from the shaft.

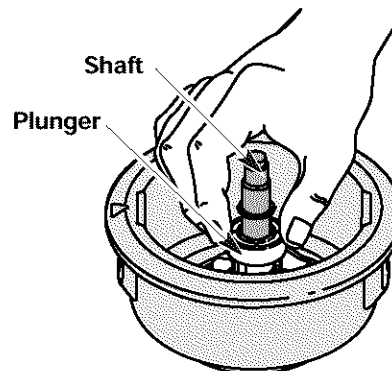

Fig. 28

NOTE: The inner reel must be totally dry before reinstalling it into the outer spool. Do not lubricate the inner reel or outer spool assembly.

6. Place the inner reel into the outer spool.
7. Place the bump knob, spring and foam seal onto the inner reel (Fig. 24).
8. Press the bump knob down and tighten clockwise.
9. Install new line as described in *Line Installation for the SpeedSpool®*.

SPEEDSPOOL® REPLACEMENT PARTS

Replacement Line	180120
Replacement Line Cartridge	753-04218
Inner Reel Spring	181465
Foam Seal	181467
Inner Reel	181464
Bump Knob Assembly	181468
(Bump Knob, Foam Seal, Spring)	

These SpeedSpool® replacement parts can be purchased from your local authorized dealer.

MAINTENANCE AND REPAIR INSTRUCTIONS

EDGER BLADE REPLACEMENT



WARNING: To avoid serious personal injury, always wear gloves while handling, removing or installing the blade.



WARNING: The gear housing gets hot after long periods of use. To avoid serious personal injury, do not touch the housing until it has cooled.

1. Line up the hole in output shaft with the locking rod slot. Insert the locking rod through the slot into the output shaft hole (Fig. 29).
2. Hold the locking rod in place by grasping it next to the boom of the unit (Fig. 30).
3. While holding the locking rod, loosen the nut on the blade by turning it **clockwise** with a 5/8 inch wrench (Fig. 31). Remove the nut, retaining washer and blade. Keep the nut and blade retainer for installation.
4. Install the new blade, blade retainer and nut (Fig. 32). Insert the locking rod through the slot into the output shaft hole. Make sure that the blade stays flat and centered against the output shaft while tightening the lock nut **counterclockwise** (Fig. 33).
5. If you have a torque wrench, tighten the nut to **325-335 in.·lbs (37-38 N·m)**, while holding the locking rod in the slot.
If you do not have a torque wrench, hold the locking rod in the slot. Rotate the nut **counterclockwise** with a 5/8 inch closed-ended or socket wrench, until the nut presses against the washer and the blade is snug. Make sure the blade assembly is installed correctly, then rotate the nut an additional **1/4-1/2 turn** (Fig. 33).
6. Remove the locking rod.



WARNING: Verify that the blade is flat against the output shaft after the nut is tightened. If the blade is off-center, the unit will vibrate excessively and may damage. Also, the blade may dislodge and fly off, possibly causing serious personal injury.

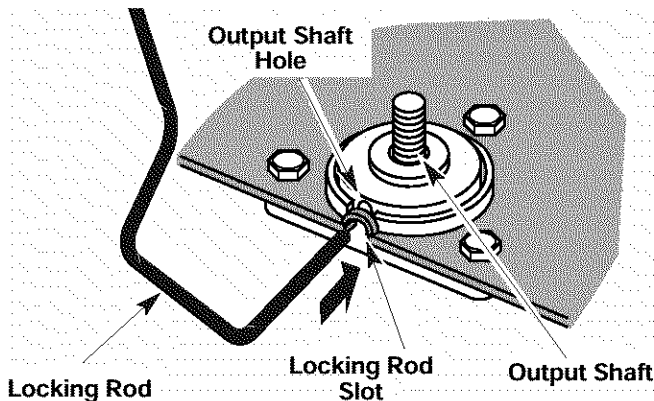

Fig. 29

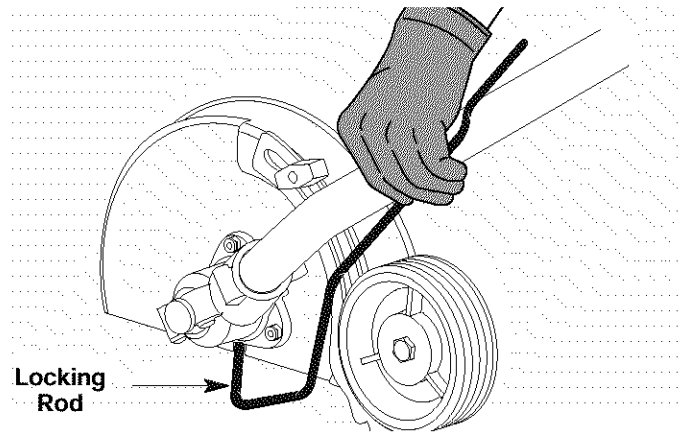

Fig. 30

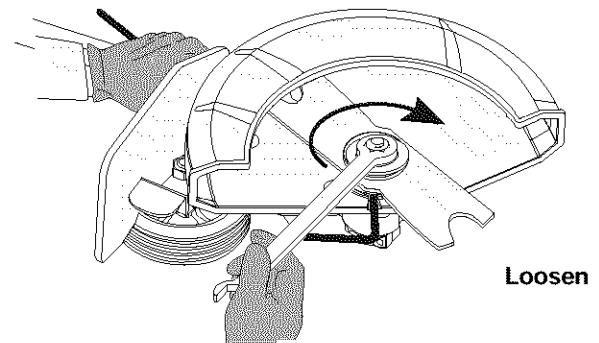

Fig. 31

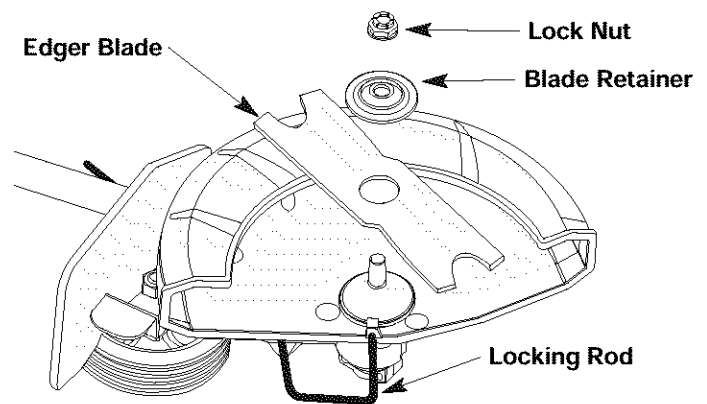

Fig. 32

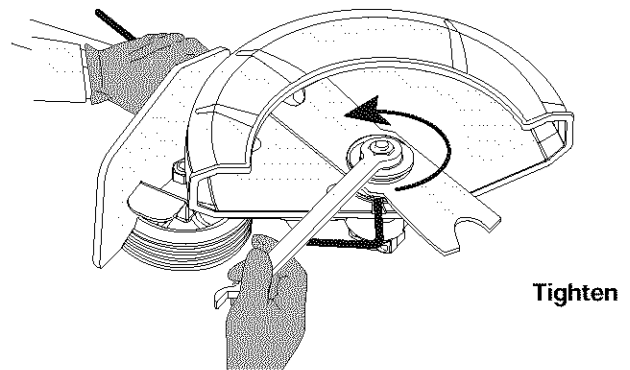

Fig. 33

MAINTENANCE AND REPAIR INSTRUCTIONS

AIR FILTER MAINTENANCE

Removing the Air Filter/Muffler Cover



WARNING: To avoid serious personal injury, always turn your trimmer off and allow it to cool before you clean or service it.

1. Remove the four (4) screws securing the air filter/muffler cover (Fig. 34). Use a flat blade or T20 Torx bit screwdriver.
2. Pull the cover from the engine. Do not force.

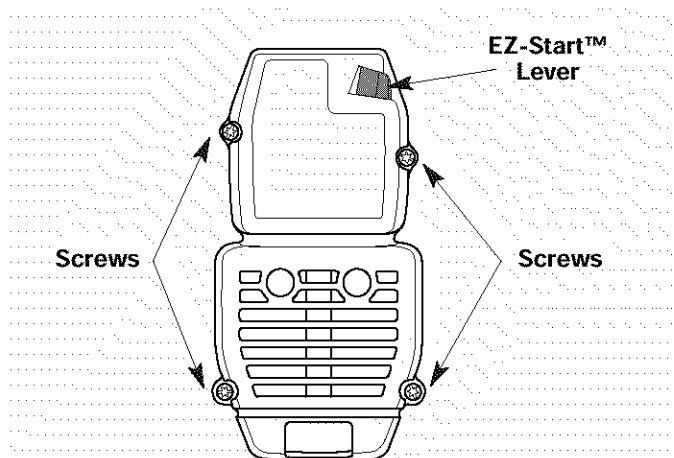

Fig. 34

Cleaning the Air Filter

Clean and re-oil the air filter every 10 hours of operation. It is an important item to maintain. Failure to maintain the air filter will VOID the warranty.

1. Remove air filter/muffler cover. Refer to *Removing the Air Filter/Muffler Cover*.
2. Turn cover over and look inside to locate the air filter. Remove the air filter from inside the air filter/muffler cover (Fig. 35).
3. Wash the filter in detergent and water (Fig. 36). Rinse the filter thoroughly. Squeeze out excess water. Allow it to dry completely.
4. Apply enough clean SAE 30 oil to lightly coat the filter (Fig. 37).
5. Squeeze the filter to spread and remove excess oil (Fig. 38).

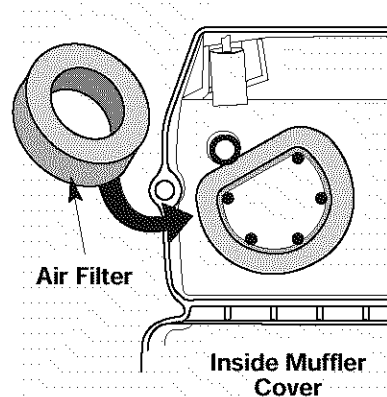

Fig. 35

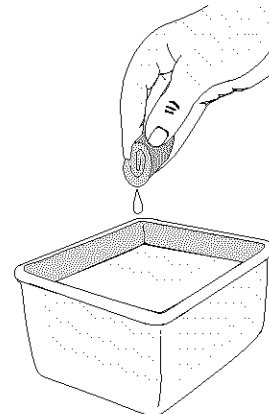

Fig. 36

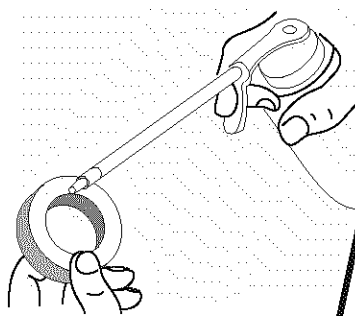

Fig. 37

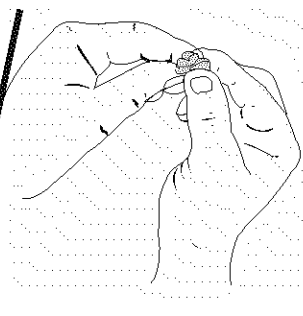

Fig. 38

6. Replace the air filter inside the air filter/muffler cover (Fig. 35).

NOTE: Operating the unit without the air filter and air filter/muffler cover assembly will VOID the warranty.

Reinstalling the Air Filter/Muffler Cover

1. Place the air filter/muffler cover over the back of the carburetor and muffler. Align the screw holes.
2. Insert the four (4) screws into the holes in the air filter/muffler cover (Fig. 34) and tighten. **Do not over tighten.**

MAINTENANCE AND REPAIR INSTRUCTIONS

SPARK ARRESTOR MAINTENANCE

1. Remove the air filter/muffler cover. See *Removing the Air Filter/Muffler Cover*.
2. Locate the muffler front and the two (2) bolts securing it to the engine (Fig. 39). Remove the two (2) bolts using a flatblade screwdriver or 5/16-inch socket or nut driver. Pull the muffler off of the engine.
3. Turn the muffler over to the back side and locate the exhaust gasket. Remove the muffler gasket from the muffler (Fig. 39).

NOTE: If exhaust gasket is torn or damaged, replace with a new gasket before reassembling muffler.

4. Using a small flatblade screwdriver, carefully pry up the spark arrester from the recessed hole (Fig. 40). Remove the spark arrester from muffler.
5. Clean the spark arrester with a wire brush. Replace it if it is damaged or if it is impossible to clean thoroughly (Fig. 40).
6. Reinstall the spark arrester by pressing it into the recessed hole on the muffler's back side. Make sure it fits tightly against the muffler and is not raised up.
7. Place the exhaust gasket against the muffler's back side. Align the exhaust gasket bolt holes with the bolt holes in the muffler. While holding the exhaust gasket in place, insert bolts into muffler's front side (Fig. 39).
8. Place the muffler (with the exhaust gasket in place and the bolts inserted,) against the engine, aligning the bolt holes. Tighten the bolts to secure the muffler to the engine.

If using a torque wrench torque to:
80-90 in.·lb. (9-10.2 N·m).

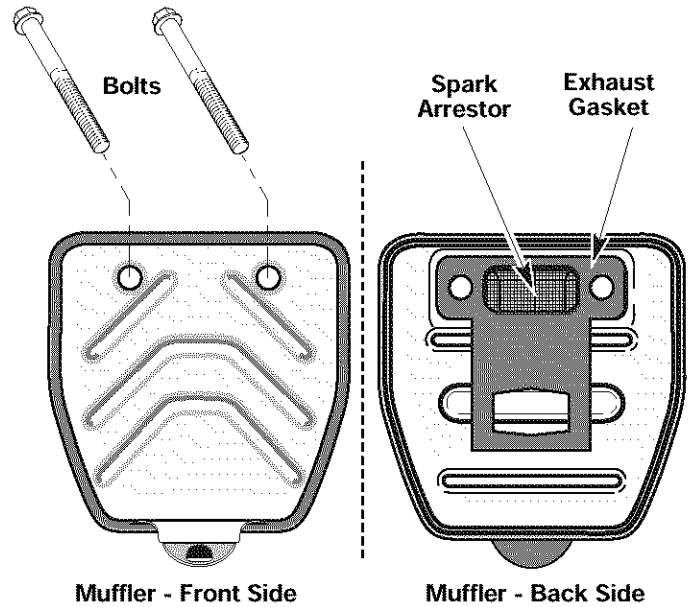

Fig. 39

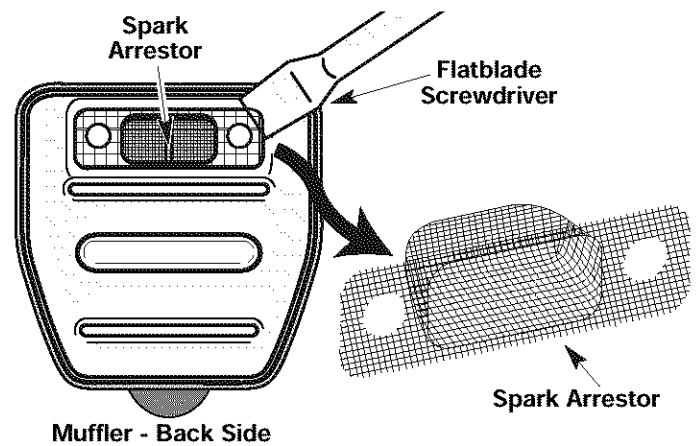

Fig. 40

WARNING: If muffler is not tightened securely, it could fall off causing damage to the unit and possible serious personal injury.

9. Reinstall air filter/muffler cover.

MAINTENANCE AND REPAIR INSTRUCTIONS

CARBURETOR ADJUSTMENT

The idle speed of the engine is adjustable through the air filter/muffler cover (Fig. 41).

NOTE: Careless adjustments can seriously damage your unit. An authorized service dealer should make carburetor adjustments.

Check Fuel Mixture

Old and/or improperly mixed fuel is usually the reason for improper unit performance. Drain and refill the tank with fresh, properly-mixed fuel prior to making any adjustments. Refer to *Oil and Fuel Information*.

Clean Air Filter

The condition of the air filter is important to the operation of the unit. A dirty air filter will restrict air flow and change the air/fuel mixture. This is often mistaken for an out of adjustment carburetor. Check the condition of the air filter before adjusting the idle speed screw. Refer to *Air Filter Maintenance*.

Adjust Idle Speed Screw

If, after checking the fuel mixture and cleaning the air filter, the engine still will not idle, adjust the idle speed screw as follows:

1. Start the engine and let it run at a high idle for a minute to warm up. Refer to *Starting/Stopping Instructions*.

WARNING: The cutting attachment may be spinning during idle speed adjustments. Wear protective clothing and observe all safety instructions to prevent serious personal injury.

2. Release the throttle trigger and let the engine idle. If the engine stops, insert a small phillips or flat blade screwdriver into the hole in the air filter/muffler cover (Fig. 41). Turn the idle speed screw in, **clockwise**, 1/8 of a turn at a time (as needed) until the engine idles smoothly.

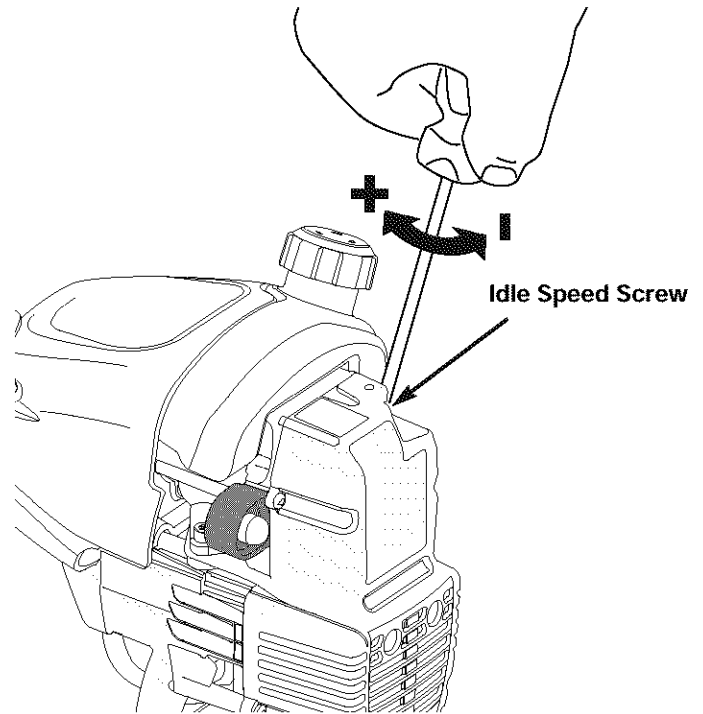

Fig. 41

NOTE: The cutting attachment should not rotate when the engine idles.

3. If the cutting attachment rotates when the engine idles, turn the idle speed screw **counterclockwise** 1/8 of a turn at a time (as needed), to reduce idle speed.

Checking the fuel mixture, cleaning the air filter, and adjusting the idle speed should solve most engine problems.

If not and all of the following are true:

- The engine will not idle
- The engine hesitates or stalls on acceleration
- There is a loss of engine power

Have the carburetor adjusted by an authorized service dealer.

WARNING: When the unit is turned off, make sure the cutting attachment has stopped before the unit is set down. This will help to prevent serious personal injury.

MAINTENANCE AND REPAIR INSTRUCTIONS

REPLACING THE SPARK PLUG

Use a Champion RDJ7Y spark plug (or equivalent). The correct air gap is **0.020 inch (0.5 mm)**. Remove the plug after every 25 hours of operation and check its condition.

1. Stop the engine and allow it to cool. Grasp the plug wire firmly and pull it from the spark plug.
2. Clean around the spark plug. Remove the spark plug from the cylinder head by turning a 5/8 in. socket counterclockwise.
3. Replace a cracked, fouled or dirty spark plug. Set the air gap at **0.020 in. (0.5 mm)** using a feeler gauge (Fig. 42).

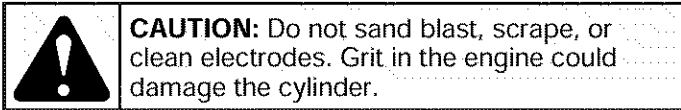

4. Install a correctly-gapped spark plug in the cylinder head. Tighten by turning the 5/8-inch socket clockwise until snug.

If using a torque wrench torque to:

110-120 in.·lb. (12.3-13.5 N·m)

Do not over tighten.

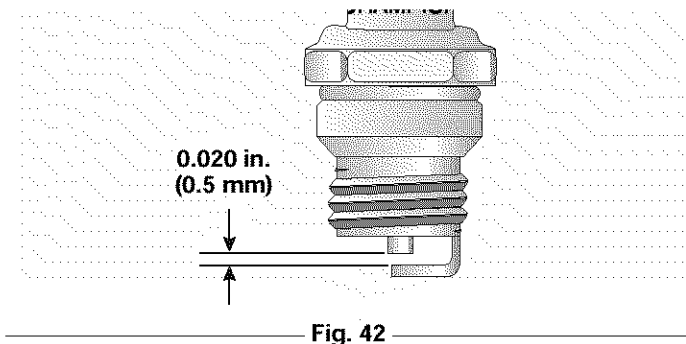

CLEANING

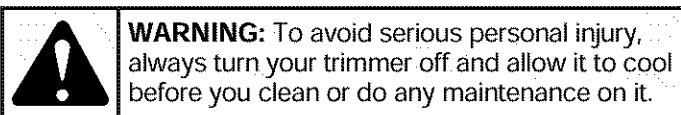

Use a small brush to clean off the outside of the unit. Do not use strong detergents. Household cleaners that contain aromatic oils such as pine and lemon, and solvents such as kerosene, can damage plastic housing or handle. Wipe off any moisture with a soft cloth.

STORAGE

- Never store the unit with fuel in the tank where fumes may reach an open flame or spark.
- Allow the engine to cool before storing.
- Store the unit locked up to prevent unauthorized use or damage.
- Store the unit in a dry, well-ventilated area.
- Store the unit out of the reach of children.

LONG TERM STORAGE

If the unit will be stored for an extended time, use the following storage procedure:

1. Drain all fuel from the fuel tank into a container with the same 2-cycle fuel mixture. Do not use fuel that has been stored for more than 60 days. Dispose of the old fuel/oil mix in accordance to Federal, State and Local regulations.
2. Start the engine and allow it to run until it stalls. This ensures that all fuel has been drained from the carburetor.
3. Allow the engine to cool. Remove the spark plug and put 1 oz. (30 ml) of any high quality motor oil or 2-cycle oil into the cylinder. Pull the starter rope slowly to distribute the oil. Reinstall the spark plug.

NOTE: Remove the spark plug and drain all of the oil from the cylinder before attempting to start the trimmer after storage.

4. Thoroughly clean the unit and inspect it for any loose or damaged parts. Repair or replace damaged parts and tighten loose screws, nuts or bolts. The unit is ready for storage.

TRANSPORTING

- Allow the engine to cool before transporting.
- Drain fuel from unit.
- Tighten fuel cap before transporting.
- Secure the unit while transporting.

ACCESSORIES/REPLACEMENT PARTS

2-Cycle Oil	147543
Spark Plug	610311
Replacement Line	180120
Replacement Line Cartridge	753-04218
Fuel Cap	180000
Edger Blade	613223
Shoulder Strap	682075

For specific replacement parts, refer to the parts list located on the inside back cover of this manual.

TROUBLESHOOTING

ENGINE WILL NOT START

CAUSE

Empty fuel tank
Primer bulb wasn't pressed enough
Engine is flooded
Old or improperly mixed fuel
Fouled spark plug
Plugged spark arrestor
EZ-Start lever was not set

ACTION

Fill fuel tank with properly mixed fuel
Press primer bulb fully and slowly 10 times
Squeeze the trigger and pull the starter rope
Drain gas tank and add fresh fuel mixture
Replace or clean the spark plug
Clean or replace spark arrestor
Move lever to start

ENGINE WILL NOT IDLE

CAUSE

Air filter is plugged
Old or improperly mixed fuel
Improper carburetor adjustment

ACTION

Replace or clean the air filter
Drain gas tank and add fresh fuel mixture
Adjust according to the *Carburetor Adjustments* section

ENGINE WILL NOT ACCELERATE

CAUSE

Old or improperly mixed fuel
Improper carburetor adjustment
Cutting attachment bound with grass
Dirty air filter
Plugged spark arrestor

ACTION

Drain gas tank and add fresh fuel mixture
Take to an authorized service dealer for an adjustment
Stop the engine and clean the cutting attachment
Clean or replace the air filter
Clean or replace spark arrestor

ENGINE LACKS POWER OR STALLS WHEN CUTTING

CAUSE

Old or improperly mixed fuel
Improper carburetor adjustment
Fouled spark plug
Plugged spark arrestor

ACTION

Drain gas tank and add fresh fuel mixture
Take to an authorized service dealer for an adjustment
Replace or clean the spark plug
Clean or replace spark arrestor

CUTTING ATTACHMENT WILL NOT ADVANCE LINE

CAUSE

Cutting attachment bound with grass
Cutting attachment out of line
Inner reel bound up
Cutting head dirty
Line welded
Line twisted when refilled
Not enough line is exposed

ACTION

Stop the engine and clean cutting attachment
Refill with new line
Replace the inner reel
Clean inner reel and outer spool
Disassemble, remove the welded section and rewind
Disassemble and rewind the line
Push the bump knob and pull out line until 4 inches (102 mm) of line is outside of the cutting attachment

CUTTING LINE ADVANCES UNCONTROLLABLY

CAUSE

Oil, cleaner or lubricant in cutting head

ACTION

Clean and thoroughly dry the cutting head

If further assistance is required, contact your authorized service dealer.

SPECIFICATIONS

ENGINE*

Engine Type.....	Air-Cooled, 2-Cycle
Stroke.....	1.25 in. (31.75 mm)
Displacement.....	1.9 cu in. (31 cc)
Clutch Type.....	Centrifugal
Idle Speed RPM.....	2,800 - 4,000 rpm
Operating RPM.....	7,200+ rpm
Ignition Type.....	Electronic
Ignition Switch.....	Rocker Switch
Spark Plug Gap.....	0.020 in. (0.5 mm)
Lubrication.....	Fuel/Oil Mixture
Fuel/Oil Ratio.....	40:1
Carburetor.....	Diaphragm, All-Position
Starter.....	Auto Rewind
Muffler.....	Baffled with Guard
Throttle.....	Manual Spring Return
Fuel Tank Capacity.....	13 oz. (384 ml)

DRIVE SHAFT & CUTTING ATTACHMENT*

Drive Shaft Housing.....	Steel Tube, EZ-Link™
Throttle Control.....	Finger-Tip Trigger with Lock-out
Approximate Unit Weight (No fuel, with cutting attachment, shield and J-handle).....	12.25 lbs. (5.6 kg)
Cutting Mechanism.....	SpeedSpool Dual String Cutting Head
Line Spool.....	Bump Line Releaser
Line Spool Diameter.....	3 inches (76.2 mm)
Trimming Line Diameter.....	0.095 inches (2.41 mm)
Cutting Path Diameter.....	17 inches (43.18 cm)

EDGER ADD-ON*

Unit Weight (Add-On only).....	5.25 lbs. (2.36 kg)
Cutting Depth (maximum).....	2.5 in. (63.5 mm)
Wheel Diameter.....	3.75 in (95.25 mm)
Gearbox Ratio.....	1.25:1

*All specifications are based on the latest product information available at the time of printing. We reserve the right to make changes at any time without notice.

EPA Emission Control Warranty Statement

Your Warranty Rights and Obligations

The Environmental Protection Agency and Troy-Bilt LLC (Troy-Bilt) are pleased to explain the emission control system warranty on your 2002 and later small off-road engine. New small off-road engines must be designed, built and equipped to meet stringent anti-smog standards. Troy-Bilt must warrant the emission control system on your small off-road engine for the periods of time listed below provided there has been no abuse, neglect or improper maintenance of your small off-road engine.

Your emission control system may include parts such as the carburetor or fuel-injected system, the ignition system, and catalytic converter. Also included may be hoses, belts, connectors and other emission-related assemblies.

Where a warrantable condition exists, Troy-Bilt will repair your small off-road engine at no cost to you including diagnosis, parts and labor.

The 2002 and later small off-road engines are warranted for two years. If any emission-related part on your engine is defective, the part will be repaired or replaced by Troy-Bilt.

Owners Warranty Responsibilities

- As the small off-road engine owner, you are responsible for the performance of the required maintenance listed in your operator's manual. Troy-Bilt recommends that you retain all receipts covering maintenance on your small off-road engine, but Troy-Bilt cannot deny warranty solely for the lack of receipts or for your failure to ensure the performance of all scheduled maintenance.
- As the small off-road engine owner, you however should be aware that Troy-Bilt may deny you warranty coverage if your small off-road engine or a part has failed due to abuse, neglect, improper maintenance or unapproved modifications.
- You are responsible for presenting your small off-road engine to a Troy-Bilt Authorized Service Center as soon as a problem exists. The warranty repairs should be completed in a reasonable amount of time, not to exceed 30 days.

If you have any questions regarding your warranty rights and responsibilities, you should call 1-800-520-5520.

Manufacturer's Warranty Coverage

- The warranty period begins on the date the engine or equipment is delivered to the retail purchaser.
- The manufacturer warrants to the initial owner and each subsequent purchaser, that the engine is free from defects in material and workmanship which cause the failure of a warranted part for a period of two years.
- Repair or replacement of warranted part will be performed at no charge to the owner at an Authorized Troy-Bilt Service Center. For the nearest location please contact Troy-Bilt at: 1-800-520-5520.
- Any warranted part which is not scheduled for replacement, as required maintenance or which is scheduled for only for regular inspection to the effect of "Repair or Replace as Necessary" is warranted for the warranty period. Any warranted part which is scheduled for replacement as required maintenance will be warranted for the period of time up to the first scheduled replacement point for that part.
- The owner will not be charged for diagnostic labor which leads to the determination that a warranted part is defective, if the diagnostic work is performed at an Authorized Troy-Bilt Service Center.
- The manufacturer is liable for damages to other engine components caused by the failure of a warranted part still under warranty.
- Failures caused by abuse, neglect or improper maintenance are not covered under warranty.
- The use of add-on or modified parts can be grounds for disallowing a warranty claim. The manufacturer is not liable to cover failures of warranted parts caused by the use of add-on or modified parts.
- In order to file a claim, go to your nearest Authorized Troy-Bilt Service Center. Warranty services or repairs will be provided at all Authorized Troy-Bilt Service Centers.
- Any manufacturer approved replacement part may be used in the performance of any warranty maintenance or repair of emission related parts and will be provided without charge to the owner. Any replacement part that is equivalent in performance or durability may be used in non-warranty maintenance or repair and will not reduce the warranty obligations of the manufacturer
- The following components are included in the emission related warranty of the engine, air filter, carburetor, primer, fuel lines, fuel pick up/ fuel filter, ignition module, spark plug and muffler.

PARTS LIST

ENGINE PARTS - MODEL TB25ET 2-CYCLE GAS TRIMMER - ENGINE PPN 41BDT2EC063

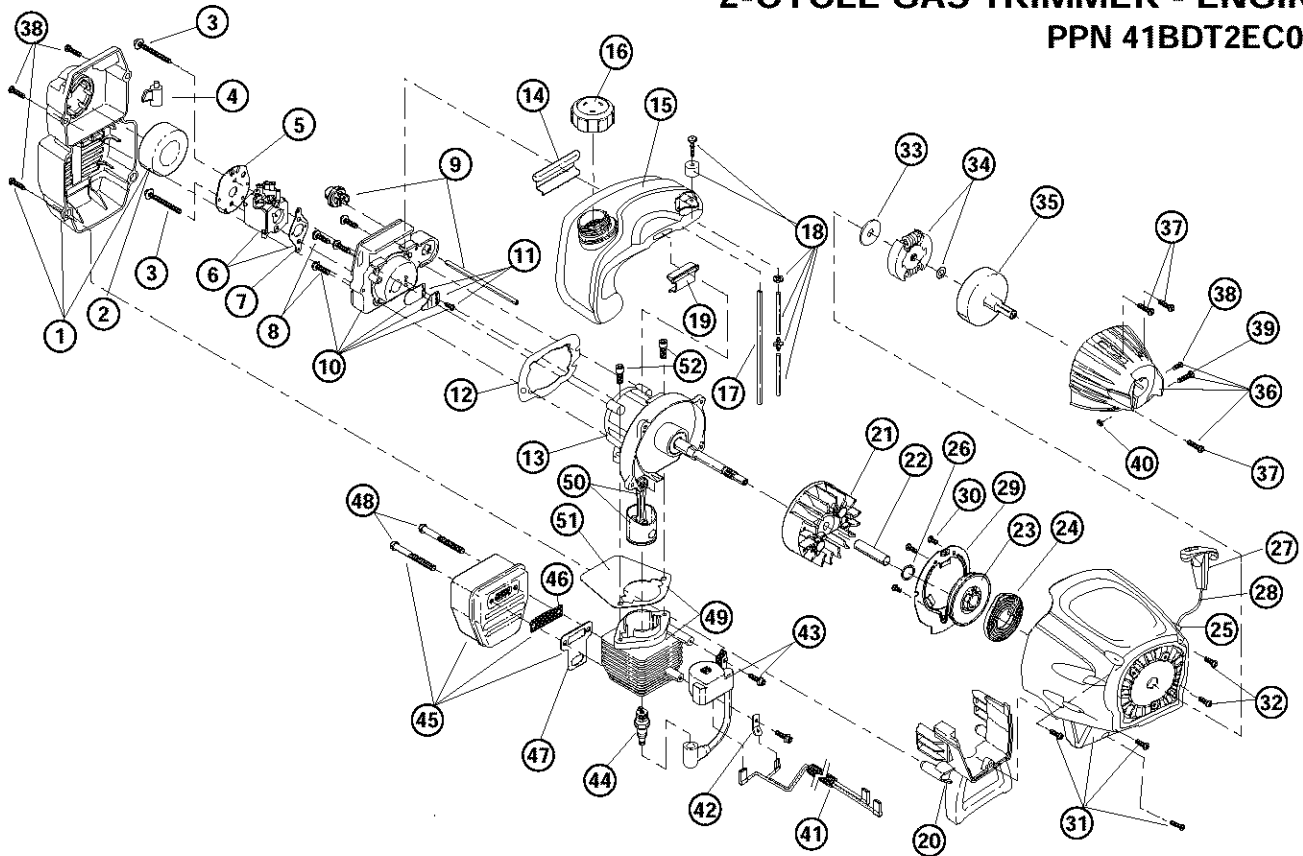

Item	Part No.	Description	Item	Part No.	Description
1	753-1192	Air Cleaner/Muffler Cover Assembly (includes 2 & 40)	31	753-1203	Starter Housing Assembly (includes 25-32 & 34)
2	791-180350B	Air Cleaner Filter	32	791-181862	Housing Screw
3	791-180351	Carburetor Mounting Screws	33	791-182368	Clutch Washer
4	753-1193	Choke Extension	34	791-182369	Clutch Rotor Assembly
5	753-1194	Choke Plate	35	791-153592	Clutch Drum Assembly
6	753-04338	Carburetor Assembly (includes 7 & 18)	36	753-1204	Clutch Cover Assembly (includes 40-43)
7	791-610675	Carburetor Gasket	37	791-181345	Cover Screw
8	791-181860	Carb Mount Screw	38	791-182519	Anti-Rotation Screw
9	791-181801	Primer and Hose Assembly	39	753-04003	Clamping Screw
10	753-1196	Carb Mount Assembly (includes 8 & 11)	40	791-180217	Clamping Nut
11	791-684451	Reed Assembly	41	791-182798	Wire Leads and Sleeve
12	753-1208	Carburetor Mount Gasket	42	791-611063	Ground Tab
13	753-04332	Crank Case Service Assembly (includes 8)	43	753-04337	Module Assembly
14	791-612134	Rear Mounting Pad	44	791-610311B	Spark Plug
15	753-04307	Fuel Tank Assembly (includes 16-18)	45	791-182066	Muffler Assembly (includes 49-51)
16	753-04084	Fuel Cap Assembly	46	791-182747	Spark Arrestor Screen
17	791-181168	Fuel Return Line	47	753-04159	Exhaust Gasket
18	753-04233	Fuel Line Assembly	48	791-147575	Muffler Mounting Bolt Assembly
19	791-145308	Front Mounting Pad	49	753-04323	Cylinder Assembly (includes 54)
20	791-182064	Shroud Extension and Stand	50	753-1207	Piston and Rod Assembly
21	791-182736	Flywheel Assembly	51	753-1197	Cylinder Gasket
22	791-181065	Spacer	52	791-182723	Cylinder Bolt
23	753-1199	Recoil Pulley Assembly	*	791-180090	O.E.M. Carburetor Repair Kit
24	753-04286	Recoil Spring	*	791-180091	Gasket Diaphragm Repair Kit
25	753-1200	Rope Guide	*	753-1209	Piston Ring Set
26	791-181247	Pulley Retainer	*	753-04334	Short Block Assembly (includes 8, 13, 46, 51-54)
27	791-181079	Pull Handle	*	791-181599	Clutch Springs (Qty. 2)
28	791-613103	Rope			
29	753-1201	Pressure Plate Assembly			
30	753-1202	Plate Screw			
			*	Items Not Shown	

PARTS LIST

BOOM AND TRIMMER PARTS - MODEL TB25ET 2 CYCLE TRIMMER - BOOM PPN - 41BDT2EC063

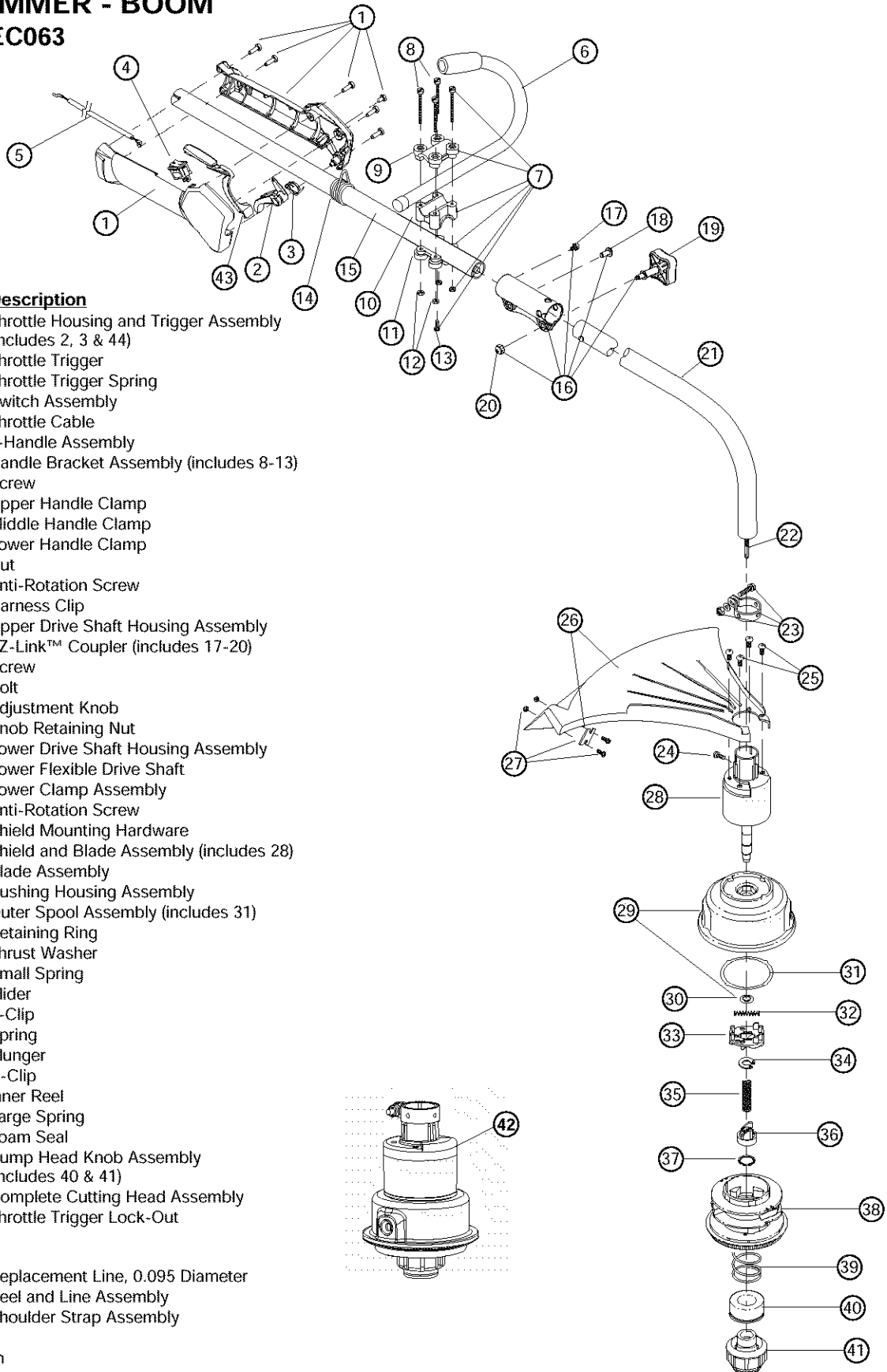

Item	Part No.	Description
1	753-04118	Throttle Housing and Trigger Assembly (includes 2, 3 & 44)
2	753-04119	Throttle Trigger
3	791-182690	Throttle Trigger Spring
4	791-182405	Switch Assembly
5	753-04136	Throttle Cable
6	791-180687	J-Handle Assembly
7	791-683295	Handle Bracket Assembly (includes 8-13)
8	791-181811	Screw
9	791-181812	Upper Handle Clamp
10	791-181813	Middle Handle Clamp
11	791-181814	Lower Handle Clamp
12	791-181815	Nut
13	791-145569	Anti-Rotation Screw
14	791-610327	Harness Clip
15	753-04236	Upper Drive Shaft Housing Assembly
16	753-1190	EZ-Link™ Coupler (includes 17-20)
17	791-182057	Screw
18	791-181617	Bolt
19	791-181981	Adjustment Knob
20	791-181886	Knob Retaining Nut
21	791-180340	Lower Drive Shaft Housing Assembly
22	791-181852	Lower Flexible Drive Shaft
23	791-153597	Lower Clamp Assembly
24	791-145569	Anti-Rotation Screw
25	791-180531	Shield Mounting Hardware
26	791-181659	Shield and Blade Assembly (includes 28)
27	791-181823	Blade Assembly
28	791-181857	Bushing Housing Assembly
29	791-181457	Outer Spool Assembly (includes 31)
30	791-181458	Retaining Ring
31	791-181561	Thrust Washer
32	791-181459	Small Spring
33	753-04257	Slider
34	791-181532	E-Clip
35	791-181531	Spring
36	791-181462	Plunger
37	791-181463	C-Clip
38	791-181464	Inner Reel
39	791-181465	Large Spring
40	791-181467	Foam Seal
41	791-181468	Bump Head Knob Assembly (includes 40 & 41)
42	791-181469	Complete Cutting Head Assembly
43	791-00041	Throttle Trigger Lock-Out

Optional Accessories

- * 791-180120 Replacement Line, 0.095 Diameter
- * 753-04218 Reel and Line Assembly
- * 791-682075 Shoulder Strap Assembly

* Items Not Shown

PARTS LIST

REPLACEMENT PARTS - MODEL TB25ET 2 CYCLE GAS TRIMMER - ADD-ON PPN 41BDT2EC063

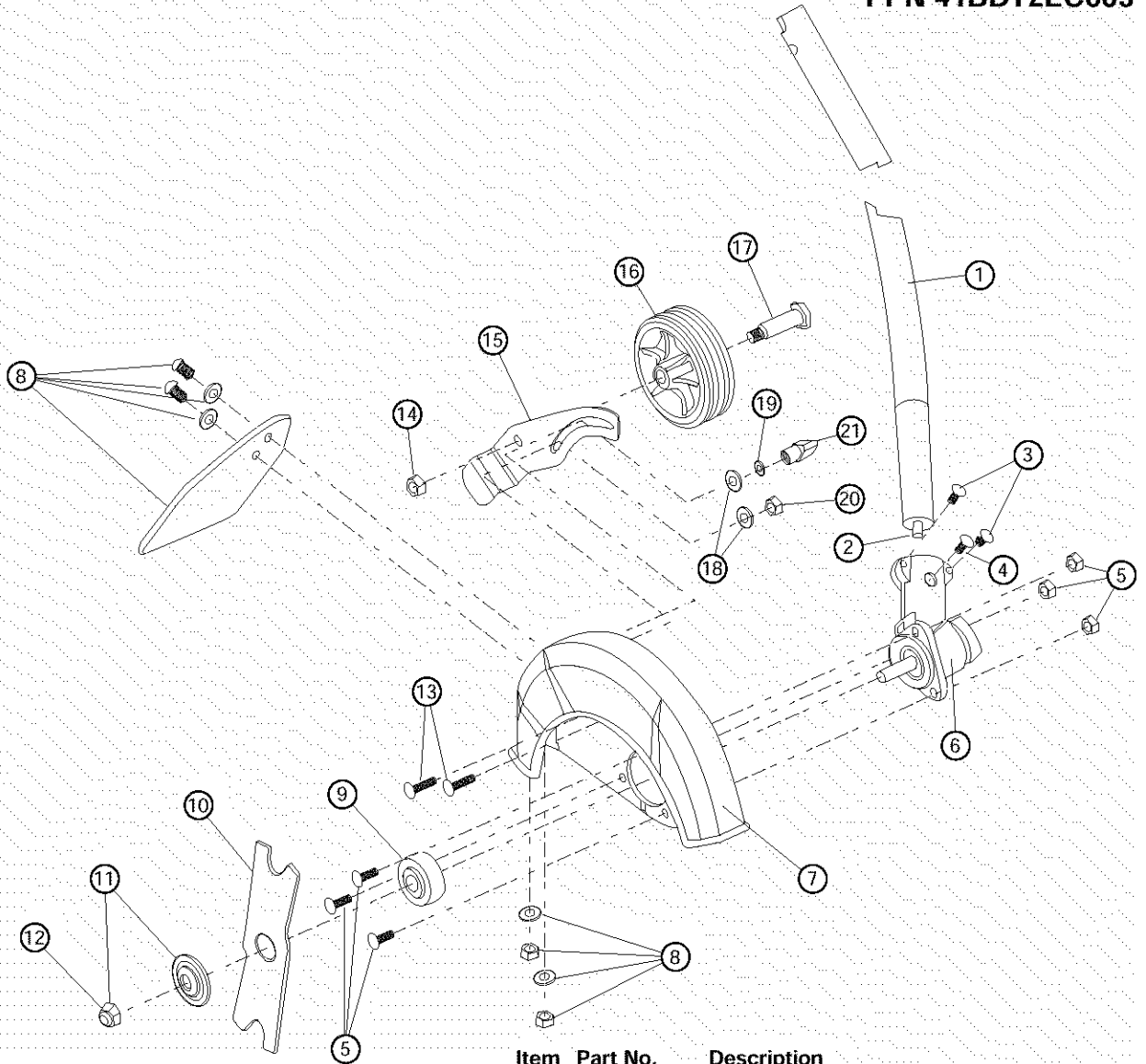

Item	Part No.	Description
1	753-04259	Boom Assembly
2	791-181570	Drive Shaft
3	791-182195	Boom Mounting Hardware
4	791-182519	Anti-Rotation Screw
5	753-1217	Guard Mounting Hardware
6	791-182193	Gearbox Assembly
7	753-04260	Blade Guard
8	753-04262	Deflector w/Hardware
9	753-04261	Spacer
10	791-613223B	Blade
11	791-180014B	Blade Clamp Washer (includes 12)
12	791-613221	Blade Retainer Nut
13	753-04270	Wheel Bracket Mounting Bolt
14	753-04264	Nut
15	753-04265	Edger Guide
16	791-181242	Wheel
17	791-180776	Shoulder Bolt
18	791-182216	Washer
19	791-182215	Washer
20	791-180050	Nut
21	791-182214	Edger Guide Knob

MANUFACTURER'S LIMITED WARRANTY FOR:



The limited warranty set forth below is given by Troy-Bilt LLC with respect to new merchandise purchased and used in the United States, its possessions and territories.

Troy-Bilt LLC warrants this product against defects in material and workmanship for a period of two (2) years commencing on the date of original purchase and will, at its option, repair or replace, free of charge, any part found to be defective in material or workmanship. This limited warranty shall only apply if this product has been operated and maintained in accordance with the Operator's Manual furnished with the product, and has not been subject to misuse, abuse, commercial use, neglect, accident, improper maintenance, alteration, vandalism, theft, fire, water or damage because of other peril or natural disaster. Damage resulting from the installation or use of any accessory or attachment not approved by Troy-Bilt LLC for use with the product(s) covered by this manual will void your warranty as to any resulting damage. This warranty is limited to ninety (90) days from the date of original retail purchase for any Troy-Bilt product that is used for rental or commercial purposes, or any other income-producing purpose.

HOW TO OBTAIN SERVICE: Warranty service is available, WITH PROOF OF PURCHASE THROUGH YOUR LOCAL AUTHORIZED SERVICE DEALER. To locate the dealer in your area, visit our website at www.troybilt.com, check for a listing in the Yellow Pages, call **1-800-520-5520** or write to P.O. Box 361131, Cleveland, OH 44136-0019.

This limited warranty does not provide coverage in the following cases:

- A. Tune-ups - Spark Plugs, Carburetor Adjustments, Filters
- B. Wear items - Bump Knobs, Outer Spools, Cutting Line, Inner Reels, Starter Pulley, Starter Ropes, Drive Belts
- C. Troy-Bilt LLC does not extend any warranty for products sold or exported outside of the United States of America, its possessions and territories, except those sold through Troy-Bilt's authorized channels of export distribution.

Troy-Bilt LLC reserves the right to change or improve the design of any Troy-Bilt Product without assuming any obligation to modify any product previously manufactured.

No implied warranty, including any implied warranty of merchantability or fitness for a particular purpose, applies after the applicable period of express written warranty above as to the parts as identified. No other express warranty or guaranty, whether written or oral, except as mentioned above, given by any person or entity, including a dealer or retailer, with respect to any product shall bind Troy-Bilt LLC. During the period of the Warranty, the exclusive remedy is repair or replacement of the product as set forth above. (Some states do not allow limitations on how long an implied warranty lasts, so the above limitation may not apply to you.)

The provisions as set forth in this Warranty provide the sole and exclusive remedy arising from the sales. Troy-Bilt LLC shall not be liable for incidental or consequential loss or damages including, without limitation, expenses incurred for substitute or replacement lawn care services, for transportation or for related expenses, or for rental expenses to temporarily replace a warranted product. (Some states do not allow limitations on how long an implied warranty lasts, so the above limitation may not apply to you.)

In no event shall recovery of any kind be greater than the amount of the purchase price of the product sold. Alteration of the safety features of the product shall void this Warranty. You assume the risk and liability for loss, damage, or injury to you and your property and/or to others and their property arising out of the use or misuse or inability to use the product.

This limited warranty shall not extend to anyone other than the original purchaser, original lessee or the person for whom it was purchased as a gift.

How State Law Relates to this Warranty: This warranty gives you specific legal rights, and you may also have other rights which vary from state to state.

To locate your nearest service dealer dial **1-800-520-5520**.

Troy-Bilt LLC

P.O. Box 361131

Cleveland, OH 44136-0019