

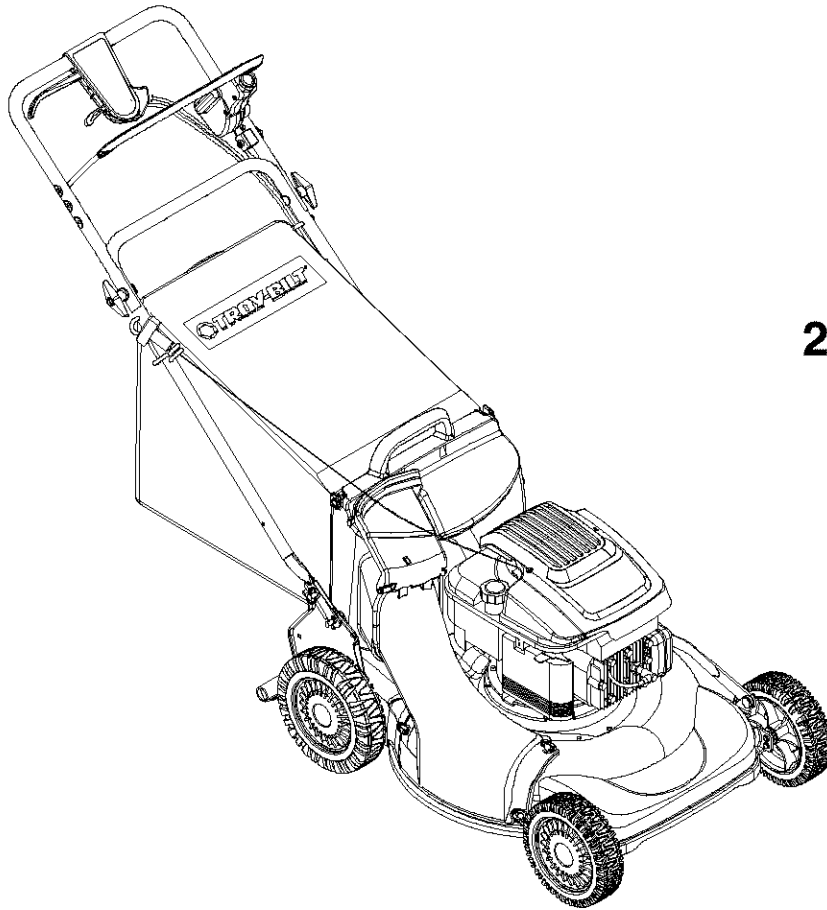

Operator's Manual



21" Smart Touch-Starter Mower

Model S979

IMPORTANT: Read safety rules and instructions carefully before operating equipment.

Warning: This unit is equipped with an internal combustion engine and should not be used on or near any unimproved forest-covered, brush-covered or grass-covered land unless the engine's exhaust system is equipped with a spark arrester meeting applicable local or state laws (if any). If a spark arrester is used, it should be maintained in effective working order by the operator. In the State of California the above is required by law (Section 4442 of the California Public Resources Code). Other states may have similar laws. Federal laws apply on federal lands. A spark arrester for the muffler is available through your nearest engine authorized service dealer or contact the service department, P.O. Box 361131 Cleveland, Ohio 44136-0019.

Troy-Bilt LLC, P.O. BOX 361131 CLEVELAND, OHIO 44136-0019

PRINTED IN U.S.A.

Form No.769-00019B
(10/2002)

TABLE OF CONTENTS

Content	Page
Important Safe Operation Practices.....	3
Slope Gauge.....	6
Assembling Your Lawn Mower.....	7
Know Your Lawn Mower.....	9
Operating Your Lawn Mower.....	10
Making Adjustments.....	12
Maintaining Your Lawn Mower.....	13
Troubleshooting.....	17
Parts List.....	20

FINDING MODEL NUMBER

This Operator's Manual is an important part of your new lawn mower. It will help you assemble, prepare and maintain the unit for best performance. Please read and understand what it says.



Before you start assembling your new equipment, please locate the model plate on the equipment and copy the information from it in the space provided below. The information on the model plate is very important if you need help from our Customer Support Department or an authorized dealer.

- You can locate the model number by standing at the operating position and looking down at the rear of the mower deck. A sample model plate is explained below. For future reference, please copy the model number and the serial number of the equipment in the space below.

_____	_____
(Model Number)	(Serial Number)
	
www.troybilt.com	
TROY-BILT LLC P. O. BOX 361131 CLEVELAND, OH 44136 330-558-7220 866-840-6483	

Copy the model number here: _____

Copy the serial number here: _____

ENGINE INFORMATION

The engine manufacturer is responsible for all engine-related issues with regards to performance, power-rating, specifications, warranty and service. Please refer to the engine manufacturer's Owner's/Operator's Manual packed separately with your unit for more information.

CALLING CUSTOMER SUPPORT

If you have difficulty assembling this product or have any questions regarding the controls, operation or maintenance of this unit, please call the Customer Support Department.



Call **1-866-840-6483** or **1-330-558-7220** to reach a Customer Support representative. Please have your unit's model number and serial number ready when you call. See previous section to locate this information. You will be asked to enter the serial number in order to process your call.

For more details about your unit, visit our website at www.troybilt.com

SECTION 1: IMPORTANT SAFE OPERATION PRACTICES



WARNING: This symbol points out important safety instructions which, if not followed, could endanger the personal safety and/or property of yourself and others. Read and follow all instructions in this manual before attempting to operate this machine. Failure to comply with these instructions may result in personal injury. When you see this symbol—HEED ITS WARNING.

WARNING: Engine exhaust, some of its constituents, and certain vehicle components contain or emit chemicals known to State of California to cause cancer and birth defects or other reproductive harm.

WARNING: This machine was built to be operated according to the rules for safe operation in this manual. As with any type of power equipment, carelessness or error on the part of the operator can result in serious injury. This machine is capable of amputating hands and feet and throwing objects. Failure to observe the following safety instructions could result in serious injury or death.

General Operation

1. Read this operator's manual carefully in its entirety before attempting to assemble this machine. Read, understand, and follow all instructions on the machine and in the manual(s) before operation. Be completely familiar with the controls and the proper use of this machine before operating it. Keep this manual in a safe place for future and regular reference and for ordering replacement parts.
2. This machine is a precision piece of power equipment, not a plaything. Therefore, exercise extreme caution at all times. Your unit has been designed to perform one job: to mow grass. Do not use it for any other purpose.
3. Never allow children under 14 years old to operate this machine. Children 14 years old and over should read and understand the operation instructions and safety rules in this manual and should be trained and supervised by a parent. Only responsible individuals who are familiar with these safe operation rules should use this machine.
4. Thoroughly inspect the area where equipment is to be used. Remove all stones, sticks, wire, bones, toys and other foreign objects which could be tripped over or picked up and thrown by the blade. Thrown objects can cause serious personal injury. Plan your mowing pattern to avoid discharge of material toward roads, sidewalks, bystanders and the like. Also, avoid discharging material against a wall or obstruction which may cause discharged material to ricochet back toward the operator.
5. To help avoid blade contact or a thrown object injury, stay in the operator zone behind the handles and keep bystanders, helpers, children and pets at least 75 feet from the machine while it is in operation. Stop machine if anyone enters the area.
6. Always wear safety glasses to protect your eyes during equipment operation and while performing an adjustment or repair. Thrown objects which ricochet can cause serious injury to the eyes.
7. Wear sturdy, rough-soled work shoes and close-fitting slacks and shirts. Shirts and pants that cover the arms and legs and steel-toed shoes are recommended. Never operate this machine in bare feet, sandals, slippery or light weight (e.g. canvas) shoes.
8. Do not put hands or feet near rotating parts or under the cutting deck. Contact with the blade can amputate hands and feet.
9. A missing or damaged discharge cover can cause blade contact or thrown object injuries.
10. Many injuries occur as a result of the mower being pulled over the foot during a fall caused by slipping or tripping. Do not hold on to the mower if you are falling; release the handle immediately.
11. Never pull the mower back toward you while you are walking. If you must back the mower away from a wall or obstruction first look down and behind to avoid tripping and then follow these steps:
 - a. Step back from the mower to fully extend your arms.
 - b. Be sure you are well balanced with sure footing.
 - c. Pull the mower back slowly, no more than half way toward you.
 - d. Repeat these steps as needed.
5. Do not operate the mower while under the influence of alcohol or drugs.
6. Do not engage the self-propelled mechanism on units so equipped while starting engine.
7. The blade control handle is a safety device. Never attempt to bypass its operation. Doing so makes the safety device inoperative and may result in personal injury through contact with the rotating blade. The blade control handle must operate easily in both directions and automatically return to the disengaged position when released.
8. Never operate the mower in wet grass. Always be sure of your footing. A slip and fall can cause serious personal injury. If you feel you are losing your footing, release the blade control handle

immediately and the blade will stop rotating within three seconds.

9. Mow in daylight or good artificial light; walk, not run.
10. Stop the blade when crossing gravel drives, walkways or roads.
11. If the equipment should start to vibrate abnormally, stop the engine and check immediately for the cause. Vibration is generally a warning of trouble.
12. Shut the engine off and wait until the blade comes to a complete stop before removing the grass catcher or unclogging the chute. The cutting blade continues to rotate for a few seconds after the engine is shut off. Never place any part of the body in the blade area until you are sure the blade has stopped rotating.
13. Never operate mower without proper trail shield, discharge cover, grass catcher, blade control handle or other safety protective devices in place and working. Never operate mower with damaged safety devices. Failure to do so can result in personal injury.
14. Muffler and engine become hot and can cause a burn. Do not touch.
15. Only use parts and accessories made by the original equipment manufacturer (O.E.M). Failure to do so can result in personal injury.
16. If situations occur which are not covered in this manual, use care and good judgment. Contact your dealer for assistance. Call 1-866-840-6483 for the name of your nearest dealer.

Slope Operation

Slopes are a major factor related to slip and fall accidents which can result in severe injury. Operation on slopes requires extra caution. If you feel uneasy on a slope, do not mow it. Before operating this unit on a slope or hilly area, use the slope gauge on page 6 to measure slopes. If the slope is greater than 15 degrees, do not mow it.

Do:

1. Mow across the face of slopes; never up and down. Exercise caution when changing direction.
2. Watch for holes, ruts, rocks, hidden objects, or bumps which can cause you to slip or trip. Tall grass can hide obstacles.
3. Always be sure of your footing. A slip and fall can cause serious personal injury. If you feel you are losing your balance, release the blade control handle immediately, and the blade will stop rotating within 3 seconds.

Do Not:

1. Do not mow near drop-offs, ditches or embankments, you could lose your footing or balance.
2. Do not mow slopes greater than 15 degrees as shown on the slope gauge.

3. Do not mow on wet grass. Unstable footing could cause slipping.

Children

Tragic accidents can occur if the operator is not alert to the presence of children. Children are often attracted to the mower and the mowing activity. They do not understand the dangers. Never assume that children will remain where you last saw them.

1. Keep children out of the mowing area and under the watchful care of a responsible adult other than the operator.
2. Be alert and turn mower off if a child enters the area.
3. Before and while moving backwards, look behind and down for small children.
4. Use extreme care when approaching blind corners, doorways, shrubs, trees, or other objects that may obscure your vision of a child who may run into the mower.
5. Keep children away from hot or running engines. They can suffer burns from a hot muffler.
6. Never allow children under 14 years old to operate a power mower. Children 14 years old and over should read and understand the operation instructions and safety rules in this manual and should be trained and supervised by a parent.

Service

Safe Handling of Gasoline:

1. To avoid personal injury or property damage use extreme care in handling gasoline. Gasoline is extremely flammable and the vapors are explosive. Serious personal injury can occur when gasoline is spilled on yourself or your clothes which can ignite.
2. Wash your skin and change clothes immediately.
3. Use only an approved gasoline container.
4. Never fill containers inside a vehicle or on a truck or trailer bed with a plastic liner. Always place containers on the ground away from your vehicle before filling.
5. If possible, remove gas-powered equipment from the truck or trailer and refuel it on the ground. If this is not possible, then refuel such equipment on a trailer with a portable container, rather than from a gasoline dispenser nozzle.
6. Keep the nozzle in contact with the rim of the fuel tank or container opening at all times until fueling is complete. Do not use a nozzle lock-open device.
7. Extinguish all cigarettes, cigars, pipes and other sources of ignition.
8. Never fuel machine indoors because flammable vapors will accumulate in the area.
9. Never remove gas cap or add fuel while the engine is hot or running. Allow engine to cool at least two minutes before refueling.

10. Never over fill fuel tank. Fill tank to no more than ½ inch below bottom of filler neck to provide space for fuel expansion.
11. Replace gasoline cap and tighten securely.
12. If gasoline is spilled, wipe it off the engine and equipment. Move unit to another area. Wait 5 minutes before starting the engine.
13. Never store the machine or fuel container inside where there is an open flame, spark or pilot light as on a water heater, space heater, furnace, clothes dryer or other gas appliances.
14. To reduce fire hazard, keep mower free of grass, leaves, or other debris build-up. Clean up oil or fuel spillage and remove any fuel soaked debris.
15. Allow mower to cool 5 minutes before storing.

General Service:

1. Never run an engine indoors or in a poorly ventilated area. Engine exhaust contains carbon monoxide, an odorless and deadly gas.
2. Before cleaning, repairing, or inspecting, make certain the blade and all moving parts have stopped. Disconnect the spark plug wire and ground against the engine to prevent unintended starting.
3. Check the blade and engine mounting bolts at frequent intervals for proper tightness. Also, visually inspect blade for damage (e.g., bent, cracked, worn) Replace blade with the original equipment manufacturer's (O.E.M.) blade only, listed in this manual. "Use of parts which do not meet the original equipment specifications may lead to improper performance and compromise safety!"
4. Mower blades are sharp and can cut. Wrap the blade or wear gloves, and use extra caution when

- servicing them.
5. Keep all nuts, bolts, and screws tight to be sure the equipment is in safe working condition.
 6. Never tamper with safety devices. Check their proper operation regularly.
 7. After striking a foreign object, stop the engine, disconnect the spark plug wire and ground against the engine. Thoroughly inspect the mower for any damage. Repair the damage before starting and operating the mower.
 8. Never attempt to make a wheel or cutting height adjustment while the engine is running.
 9. Grass catcher components, discharge cover, and trail shield are subject to wear and damage which could expose moving parts or allow objects to be thrown. For safety protection, frequently check components and replace immediately with original equipment manufacturer's (O.E.M.) parts only, listed here. Use of parts which do not meet the original equipment specifications may lead to improper performance and compromise safety.
 10. Do not change the engine governor setting or overspeed the engine. The governor controls the maximum safe operating speed of the engine.
 11. Maintain or replace safety and instruction labels, as necessary.
 12. Observe proper disposal laws and regulations. Improper disposal of fluids and materials can harm the environment.
 13. ALWAYS de-energize self starter prior to performing any maintenance or service to the engine and or mower. Follow instructions both in manual and on the engine and or machine to de-energize starter.

Your Responsibility

- Restrict the use of this power machine to persons who read, understand and follow the warnings and instructions in this manual and on the machine.



SECTION 2: SLOPE GAUGE

Use this page as a guide to determine slopes where you may not operate safely. Do not operate your lawn mower on such slopes.

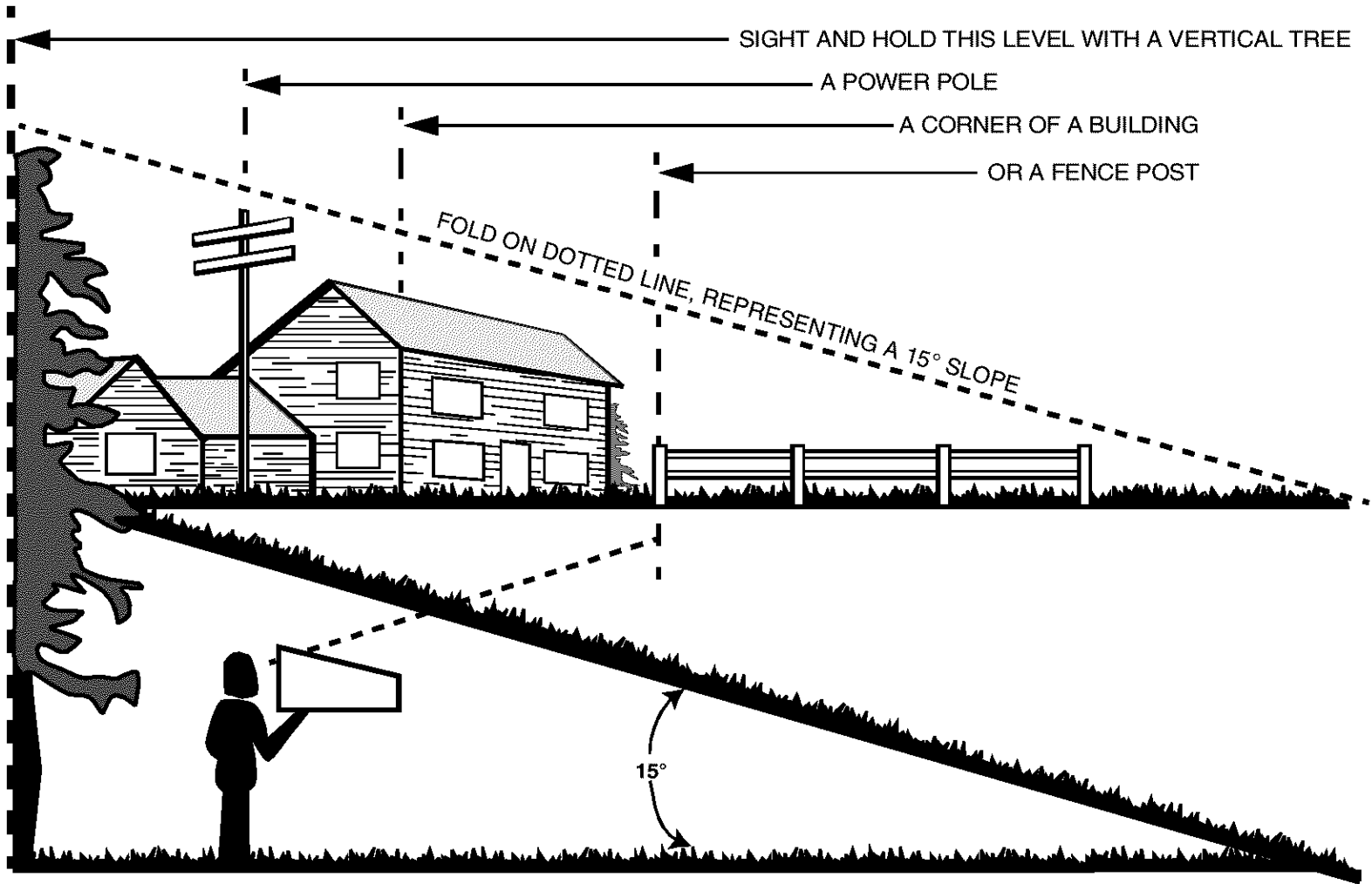

WARNING

Do not mow on inclines with a slope in excess of 15 degrees (a rise of approximately 2-1/2 feet every 10 feet). A riding mower could overturn and cause serious injury. If operating a walk-behind mower on such a slope, it is extremely difficult to maintain your footing and you could slip, resulting in serious injury.

Operate RIDING mowers up and down slopes, never across the face of slopes.

Operate WALK-BEHIND mowers across the face of slopes, never up and down slopes.

SECTION 3: ASSEMBLING YOUR LAWN MOWER

Removing Unit From Carton

- Remove staples, break glue on top flaps, or cut tape at carton end and peel along top flap to open carton.
- Remove loose parts, if included with unit (i.e., grass bag etc.), and save it appropriately.
- Cut along corners, lay the carton down flat, and remove all packing material.
- Roll or slide unit out of carton and check carton thoroughly for loose parts.

Loose Parts in Carton

1. Grass Bag
2. Grass Bag Adapter
3. Side Discharge Chute
4. Hardware Pack

Hardware Pack

Please identify each piece of the hardware pack as shown in Figure 1.

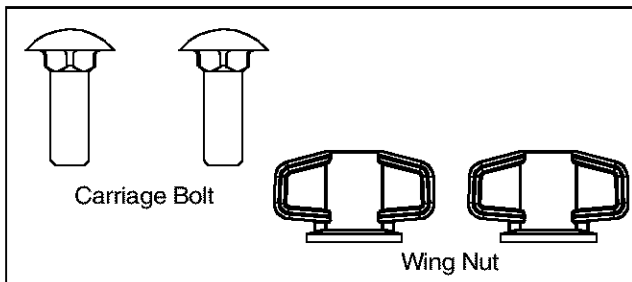

Figure 1

Before Assembly

- Before setting up your lawn mower, disconnect the spark plug wire from the spark plug and ground against the engine. See Figure 2.

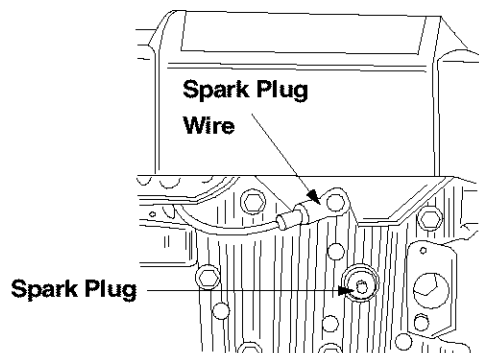

Figure 2

NOTE: Reference to right or left side of the mower is observed from the operating position.

Setting Up Your Lawn Mower

Assembling Handle

- Lift up and pull back on the upper handle to raise the handle into the operating position. See Figure 3. Make certain the lower handle is seated securely into the handle bracket assemblies.

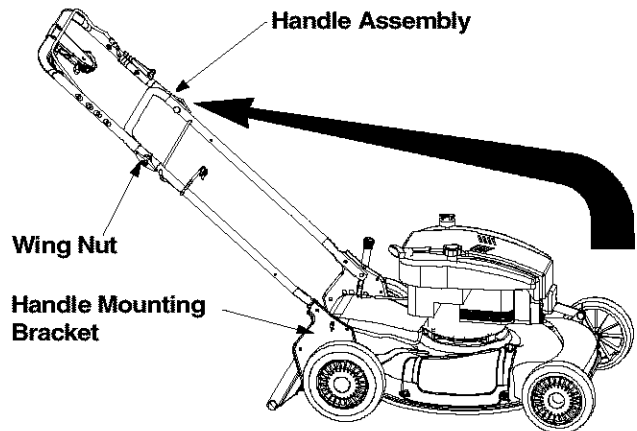

Figure 3

- Tighten wing nuts on each side of the handle making sure that the carriage bolts are seated properly into the handle. See Figure 3.
- Remove hairpin clip from the outer hole of the weld pin on each handle brackets. Using a pair of pliers, squeeze one leg of the lower handle against the handle bracket. Insert the hairpin clip into the inner hole on the weld pin. Repeat on the other side. See Figure 4.
- After moving the hairpin clip, insert the carriage bolt, from the hardware pack, in the upper hole on the handle mounting bracket and secure with plastic wing nut, also from the hardware pack. See Figure 4. Repeat on the other side.

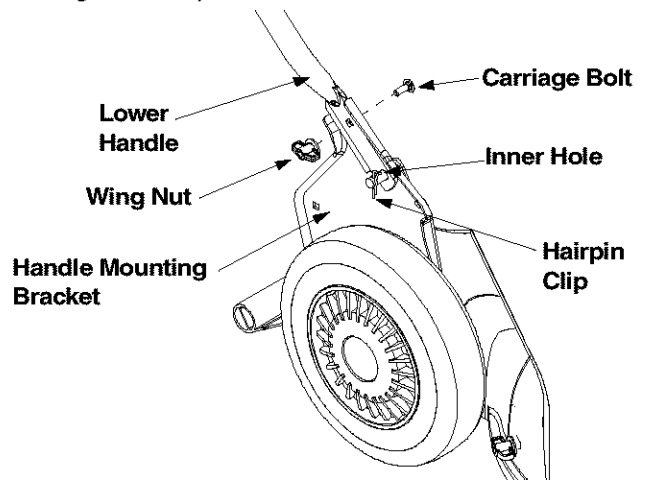

Figure 4

- Fasten the cable to the lower handle with the two cable ties found on the lower handle. Pull the cable ties tight and trim off the excess. See Figure 5.

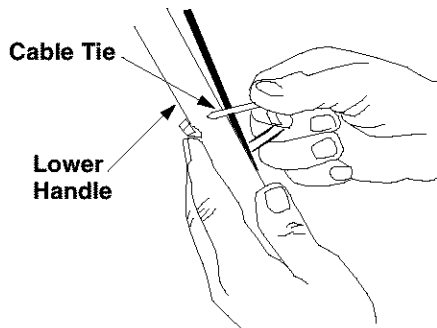

Figure 5

Attaching Starter Rope

NOTE: Make certain the drive cable is routed around the outside and above the lower handle so it does not interfere with attaching the grass bag.

- The rope guide, which is connected to the support rod, is located on the right side of the lower handle. See Figure 6.
- With the spark plug wire disconnected and grounded, hold the blade control handle against the upper handle, and pull the starter rope out of the engine. Release the blade control handle. Slip the starter rope into the rope guide.

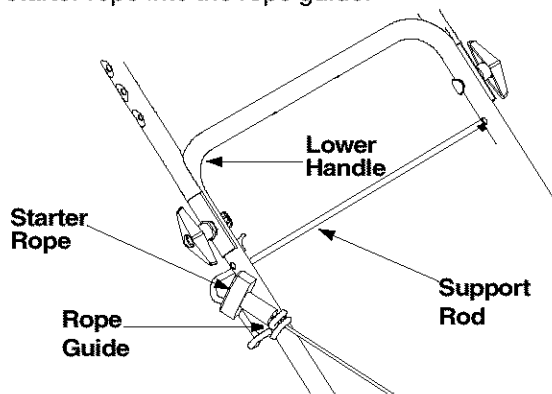

Figure 6

Attaching The Grass Bag

The mower was shipped with the mulching baffle installed on the unit. You can keep this baffle on as long as you want to mulch the grass clippings. For bagging purposes, you will have to attach the grass bag and its adapter in place of the mulching baffle.

- Remove three wing nuts holding the mulching baffle or side discharge chute in place and remove the accessory from the unit.
- Replace with grass bag adapter, while making sure the front lip of adapter goes under the edge of the deck. Secure with wing nuts previously removed. See Figure 7.

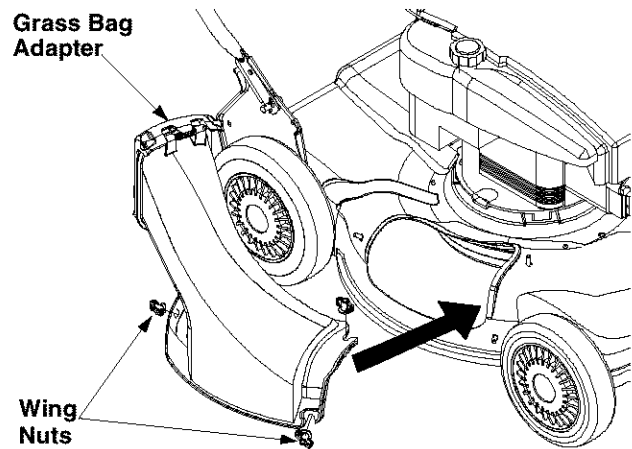

Figure 7

- Lift chute door on the grass bag adapter and slide grass bag onto the adapter. See Figure 8.

NOTE: The chute door has been designed to move the starter rope out of the way of the bag when the chute door is opened.

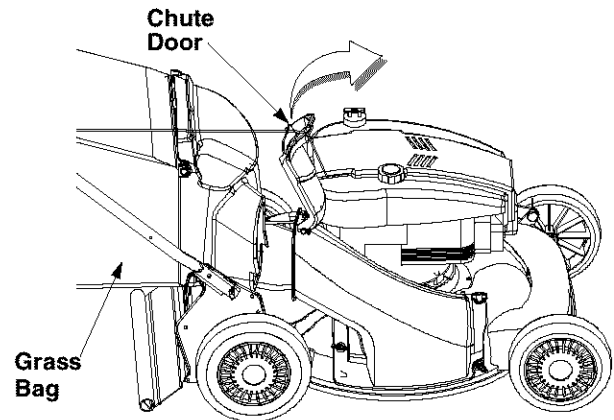

Figure 8

Attaching Side Discharge Chute

- Remove mulching baffle or grass bag adapter from unit by disconnecting wing nuts.
- Attach side discharge chute to unit and secure with the three wing nuts. See Figure 9.

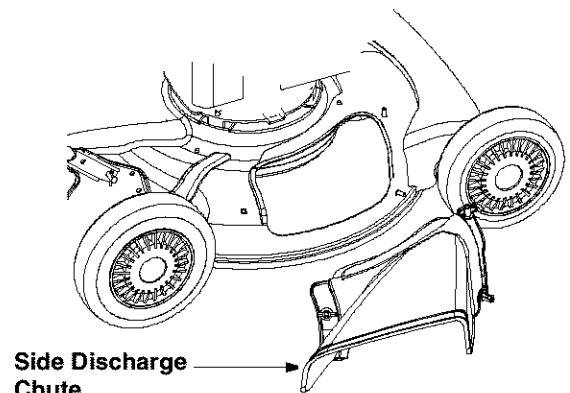

Figure 9

SECTION 4: KNOW YOUR LAWN MOWER

Read this operator's manual and safety rules before operating your lawn mower. Compare the illustration in Figure 10 with your lawn mower to familiarize yourself with the location of various controls and adjustments. Save this manual for future reference.

Blade Control Handle

The blade control handle is located on the upper handle of the mower. The blade control handle must be depressed in order to operate the unit. Release blade control handle to stop engine and blade.



WARNING: This blade control mechanism is a safety device. Never attempt to bypass its operations.

Cutting Height Adjustment Levers

The cutting height adjustment lever is located above the left rear wheel. To adjust the cutting height, refer to the Adjustment Section in this manual.

Recoil Starter

The recoil starter is attached to the right upper handle. Stand behind the unit and pull the recoil starter rope to start the unit.

Smart Touch Starter

The Smart Touch Starter button is located on the upper left side of the upper handle. This button must be depressed fully while pulling the blade control handle toward upper handle for the engine to start. The starter button will automatically return to the off/up position once the blade control handle is released.

NOTE: The starter button must be depressed to start the engine either with the Smart Touch starter or recoil starter system.

Safety Key

The safety key, located on the engine, is used to activate/deactivate the Smart Touch starter system. This key must be in the run position to start the mower for both the Smart Touch starter and the recoil starter. See your engine manual for more information.

Drive Clutch Control

The drive clutch control is located on the upper handle. Squeeze the drive control to engage the drive system. Release the clutch control to disengage the drive system. Release the clutch control to slow down when approaching an obstacle, making a turn, or stopping.

Shift Lever

The shift lever is located on the drive clutch control housing on the upper handle. This lever is used to select the forward speed of the mower. When changing speed selection, release the drive clutch control.

NOTE: Move the shift lever only when the engine is running. Changing the shift lever setting with the engine off can damage the mower.

Mulching Plug

The mulching plug is used only for mulching purposes. Instead of collecting grass clippings in a grass catcher, this mower has the option of recirculating the clippings back to the lawn.

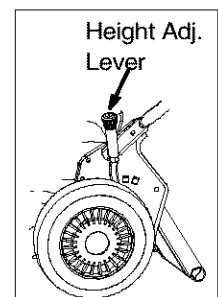
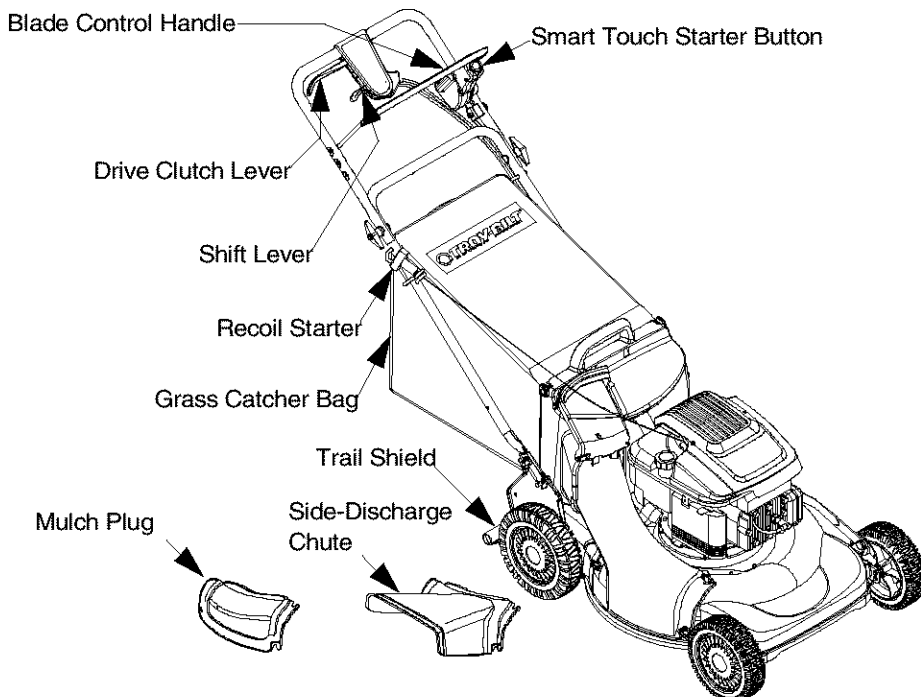

Figure 10

SECTION 5: OPERATING YOUR LAWN MOWER



WARNING: Read, understand, and follow all instructions and warnings on the machine and in this manual before operating.

NOTE: For shipping purposes your mower is set with the wheels in a low cutting height position. For best results, raise the cutting position until it is determined which height is best for your lawn. See the Adjustment Section for details.

Gas & Oil Fill-Up

- Check oil level and add oil if necessary. Follow instructions in the engine manual.
- Service the engine with gasoline as instructed in the engine manual.



WARNING: Use extreme care when handling gasoline. Gasoline is extremely flammable and the vapors are explosive. Never fuel the machine indoors or while the engine is hot or running. Extinguish cigarettes, cigars, pipes and other sources of ignition.

Before Starting Mower

- Attach spark plug wire to spark plug. Make certain the metal cap on the end of the spark plug wire (inside the rubber boot) is fastened securely over the metal tip on the spark plug.
- Check for proper drive clutch operation using the neutral adjustment test described below.

Neutral Adjustment Test

To perform this test, answer the following questions.

- With the drive clutch control released, push mower forward and pull it backward. Does it move freely?
- Squeeze the drive clutch control and pull the mower backward. Do the rear wheels lock?
- If you answered “yes” to both questions, your mower passed the test and you can start it.
- If you answered “no” to any of these, adjust the drive clutch control as instructed on page 12.

Starting the Engine

Starting first time

NOTE: Use recoil starter rope to start engine for the very first time.

- The mower is shipped with the safety key in the locked position and the Smart Touch starter in the de-energized mode. Follow instructions below to start the engine for the first time.
1. Place lawn mower on a level surface outdoors.

2. Remove plastic wrap under fuel cap.
3. Check oil level.
4. Add fuel.
5. Open shut-off valve (if equipped) 1/4 turn.
6. Push spark plug wire firmly on spark plug.
7. Turn safety key 1/4 turn clockwise to RUN.
8. Firmly push primer bulb 3 times.
9. While standing at upper handle, depress the starter control button fully with your right thumb.
10. Using your left hand, pull the blade control handle all the way toward the upper handle.
11. Release the button.
12. Grasp the recoil rope starter handle with your right hand and slowly pull towards you until you feel a slight resistance, then pull firmly until your arm is fully extended.
13. If engine does not start by second pull, repeat steps 8, 9 10,11 and 12.

Starting second time onwards



WARNING: NEVER assume starter is in the de-energized mode, even if the key is in the locked position and or removed from the engine. ALWAYS de-energize starter prior to performing any maintenance or service to the engine and or mower. Follow instructions on the engine and or machine to de-energize starter.

- Follow these instructions if the Smart Touch starter is already in the energized mode.
1. Check oil level and add fuel, if necessary.
 2. Open shut off valve (if equipped) 1/4 turn.
 3. Turn safety key 1/4 turn clockwise to RUN position.
 4. Prime three times (for a cold engine only).
 5. While standing at upper handle, depress the starter control button with your right thumb.
 6. Using your left hand, pull the blade control handle all the way toward the upper handle. Starter will de-energize and engine will start.

NOTE: If engine does not start, release blade control handle and follow steps 8, 9, 10, 11 and 12 in the Starting first time” instructions.

To Stop Engine and Blade

1. Release safety blade control handle (the start control button will automatically return to the OFF/UP). The engine and the blade will stop within a few seconds. Keep your hands and feet away till the blade stops completely.

NOTE: Engine may stop with a ratcheting sound. This sound is the Smart Touch starter being reactivated/energized for the next start.

2. Turn safety key 1/4 turn counterclockwise to LOCK position. Remove key and store in a safe place.

To De-Energize Smart Touch Starter

- Remove spark plug wire from spark plug.
- Turn safety key to RUN position (1/4 turn clockwise).
- While standing in the operating position, depress the starter control button fully with your right thumb.
- Using your left hand, pull the control handle all the way toward the upper handle. (Release button and wait until blade and starter stop rotating).
- Release safety blade control handle (the start control button will automatically return to OFF/UP).
- Remove safety key.

NOTE: Engine will crank upon actuating equipment starting controls, but will not spark if spark plug wire was removed from spark plug as described above. Once engine has stopped cranking, Smart Touch starter is de-energized.



WARNING: To operate the Smart Touch Starting system, follow the safety instructions listed below. Remember that any breach of these instructions may result in amputation or severe laceration.

Maintaining Safety in Operation

- Always disconnect spark plug, de-energize starter, lock and remove safety key before performing any service to the engine or mower.
- Do not attempt any maintenance or repairs to the Smart Touch starter.
- Never assume starter is de-energized, even if key is in lock and remove position and/or removed from engine.
- Always de-energize Smart Touch starter
 - a. before removing grass or other debris from under mower deck;
 - b. before changing oil, air filter or spark plug;
 - c. before removing blade for servicing;
 - d. before performing any other service to engine or mower; and
 - e. before transporting mower.
- Always lock and remove safety key and store in a safe place until next use. The safety key is designed and intended to be removed from engine when not in use. The safety key must be in the locked position before it can be removed.

Using Your Lawn Mower

- **Do not** operate the mower without any one of the mulching baffle, discharge chute or grass catcher properly installed.
- *For best results, do not cut wet grass.* It may stick to the underside of the mower, preventing proper

discharge of grass clippings, and could cause you to slip and fall. New grass or thick grass may require a narrower cut.

- For a *healthy lawn*, always cut off one-third or less of the total length of the grass. Lawn should be trimmed in fall as long as there is growth.

IMPORTANT: Move the shift lever only when the engine is running. Changing the shift lever setting with the engine off can cause damage to the mower.



WARNING: If the mower strikes a foreign object, stop the engine. Remove spark plug wire from the spark plug and thoroughly inspect for any damage. Repair the damage promptly before restarting and operating the mower.

WARNING: Be sure that the lawn is clear of stones, sticks, wire, or other objects which could damage lawn mower or engine. Such objects could be accidentally thrown by the mower in any direction and cause serious personal injury to the operator and others.

Mulching

For effective mulching, do not cut wet grass. New or thick grass may require a narrower cut. If the grass has grown in excess of 4", mulching is not recommended. Mow using the side discharge to reduce the grass height to 3.25" maximum before mulching.

Bagging Grass Clippings

You can use the grass catcher bag to collect clippings while you are operating the mower.

- Attach grass catcher following instructions on page 8 of this manual. Grass clippings will automatically collect in the bag as you run the mower.
- Operate the mower till the grass bag is full.
- Stop engine completely by releasing the blade control handle. Make sure that the unit has come to a complete stop.
- While holding the grass bag by both the rear handle and the lower handle, lift the grass bag straight up off the adapter. The chute door will move the rope out of the way of the bag.
- Continue to hold the lower handle and raise the rear of the grass bag up toward your chest. The grass bag will open and the grass clippings will disperse.
- When replacing the grass bag, be sure the top of the bag rests on the wire support between the handles.

SECTION 6: MAKING ADJUSTMENTS



WARNING: Do not at any time make any adjustments without first stopping engine and disconnecting spark plug wire.

Cutting Height

Your mower is shipped with the cutting height in the lowest position. The cutting height adjustment lever is located above the left rear wheel. To adjust the cutting height, proceed as follows:

- Pull the lever out and away from the mower and then move it forward or backward to another slot. See Figure 11.

NOTE: For rough or uneven lawns, move the height adjustment lever to a higher position. This will help stop scalping.

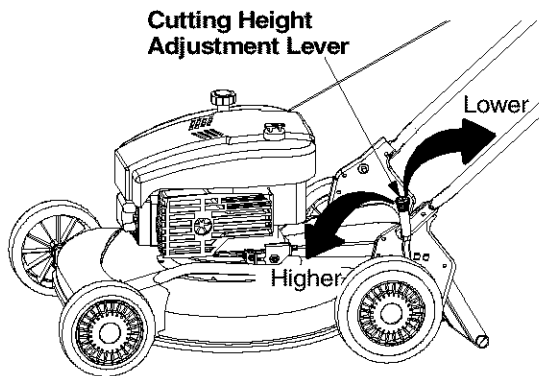

Figure 11

Handle Height

Your mower is shipped with the handle in the higher height position. To lower the height, proceed as follows:

- Remove the starter rope from the rope guide.
- Remove the wing nuts and carriage bolts securing the upper handle. Remove and lay the upper handle out of the way, being careful not to bend or kink the cables.
- Remove the hairpin clips from the weld pins on the handle brackets and remove the wing nuts and carriage bolts from the upper hole on the handle mounting bracket.
- Press out on the legs of the lower handle and remove lower handle from the mower.
- Turn lower handle around so the notch on the bottom of the lower handle is facing forward. See Figure 12

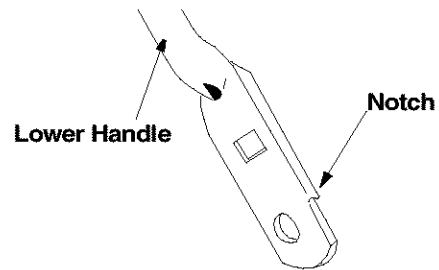

Figure 12

- Reassemble the handles, placing the bottom holes in the handle over the weld pins in the handle mounting bracket.
- Place the hairpin clips in the inner holes in the weld pins and insert the carriage bolts through the upper hole on the handle mounting bracket and secure with plastic wing nuts.
- Reassemble the upper handle to the lower handle.
- Attach the starter rope as instructed on page 8.

Drive Clutch Control

The adjustment wheel is located in the drive clutch control handle housing and is used to tighten or loosen the drive belt. You will have to adjust the drive clutch control if any of the following happens:

1. The mower does not propel itself with the drive clutch engaged.
 2. The mower's drive wheels hesitate with the drive clutch engaged.
- To resolve the above problems, rotate the adjustment wheel with your fingers: clockwise to tighten the cable and counter-clockwise to loosen the cable. See Figure 13.

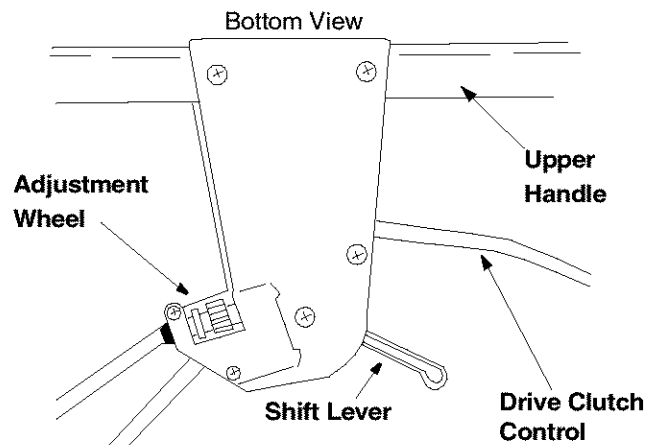

Figure 13

NOTE: For some people the drive clutch control may not be in a comfortable position. You can adjust the handle out by tightening the adjustment wheel.

Shift Lever Cable

Periodic adjustment of the three-speed shift cable may be necessary due to normal wear on the cable. Adjustment is needed if all three speeds do not work. The adjustable cable bracket is located on the left side of the mower beside the engine. See Figure 14.

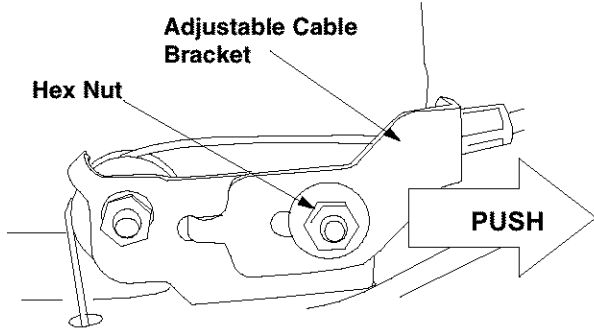

Figure 14

- Start engine and place shift lever in the third speed position. Refer to Figure 13.
- Stop engine and disconnect spark plug wire and ground it against engine.
- Loosen hex nut which secures the adjustable cable bracket. See Figure 14.
- Push back on the adjustable cable bracket and tighten hex nut.

Engine Adjustments

Refer to the engine manual for these adjustments.

SECTION 7: MAINTAINING YOUR LAWN MOWER



WARNING: Always stop the engine and disconnect the spark plug wire before performing any maintenance work or adjustments on your lawn mower.

Cleaning Mower

The underside of the mower deck should be cleaned after each use to prevent any build-up of debris. If allowed to accumulate, it will cause rust and corrosion.

NOTE: We do not recommend the use of pressure washers or garden hose to clean your unit. These may cause damage to electric components, spindles, pulleys, bearings, or the engine. The use of water will result in shortened life and reduce serviceability.

- Disconnect spark plug wire.
- Drain the gasoline from the lawn mower, or place a piece of plastic under the gas cap.
- Tip the mower so that it rests on the housing. Keep the side with the air cleaner facing *up*. Hold the mower firmly.
- Scrape and clean the underside of the deck with a suitable tool. Do *not* spray with water.
- Put the mower back on its wheels on the ground. If you had put plastic under the gas cap, make sure to remove it now.



WARNING: Never tip the mower more than 90 degrees in any directions and do not leave the mower tipped for any length of time. Oil can drain into the upper part of the engine causing a starting problem.

Engine Care

A list of key maintenance jobs required for good performance by the mower is given below. Follow the accompanying engine manual for detailed list and instructions.

- Change engine oil regularly, as instructed in the engine manual. Check oil level before starting engine every time.
- Service foam filter in the air cleaner every 25 hours of use and replace the paper filter component every 100 hours. You may have to service the air filter more frequently if you are operating the mower under extremely dusty conditions.
- Clean the engine periodically. Remove dirt and debris with a cloth or brush.
- Clean the spark plug and reset the gap to .030" at least once a season. Refer to the engine manual for correct spark plug type.
- Inspect muffler periodically, and replace if necessary. Damaged mufflers or spark arresters can create a fire hazard. Make sure to avoid muffler and surrounding areas while the mower engine is hot because temperature of these areas of the engine may exceed 150° F.

Lubrication

Blade Control Handle

- Lubricate the pivot points on the blade control handle at least once a season with light oil. The blade control must operate freely in both directions.

Rear Discharge Door

- Lubricate the torsion spring and the pivot point on each end of the rear discharge door using a light oil. This will prevent rusting of the discharge door.

Wheels

- Lubricate the wheels and bearings, if so equipped, at least once a season with light oil or engine oil.

Also, if the wheels are removed for any reason, lubricate the surface of the axle bolt and the inner surface of the wheel with light oil.

Engine

- Follow the engine manual instructions and recommended schedule for lubricating engine components

SECTION 8: SERVICING THE MOWER



WARNING: Always stop the engine and disconnect the spark plug wire before performing any maintenance work or adjustments on your lawn mower.

Blade Care



WARNING: When removing the cutting blade for sharpening or replacement, protect your hands with a pair of heavy gloves or use a heavy rag to hold the blade.

- Periodically inspect the blade adapter for cracks, especially if you strike a foreign object. Replace when necessary.

Removing the Blade

- Disconnect spark plug wire from spark plug.
- Turn mower on its side making sure that the air filter and the carburetor are up.
- Remove the bolt and the blade bell support which hold the blade and the blade adapter to the engine crankshaft. See Figure 15.
- Remove the blade and the adapter from the crankshaft.

Sharpening the Blade

- The blade can be sharpened with a file or on a grinding wheel. Do not attempt to sharpen the blade while it is still on the mower.
- Follow the original angle of grind as a guide. Make sure that each cutting edge receives an equal amount of grinding to prevent an unbalanced blade.



WARNING: An unbalanced blade will cause excessive vibration when rotating at high speeds. It may cause damage to the mower, and could break causing personal injury.

Balancing the Blade

- The blade can be tested by balancing it on a round shaft screwdriver. Remove metal from the heavy side until it balances evenly. It is recommended that the blade always be removed from the adapter when testing for balance.

Installing the Blade

- Before reinstalling the blade and the blade adapter to the unit, lubricate the engine crankshaft and the inner surface of the blade adapter with light oil.
- Be sure to install the blade with the side of the blade marked "Bottom" (or with part number) facing the ground when the mower is in the operating position.
- Slide the blade adapter onto the engine crankshaft.
- Place the blade on the adapter. Be certain the blade is aligned and seated on the blade adapter flanges.
- Place blade bell support on blade. Make sure the notches on the blade bell support are aligned with small holes in the blade.
- Replace hex bolt and tighten hex bolt to torque: 450 in. lbs. min., 600 in. lbs. max.

NOTE: To ensure safe operation of your mower, periodically check the blade bolt for correct torque.

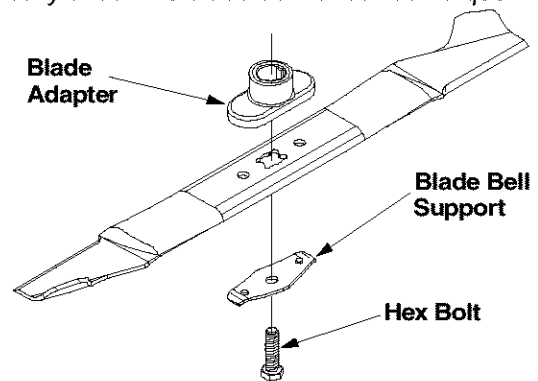

Figure 15

Drive Belt Replacement

- Disconnect the spark plug wire and ground it against the engine.
- Drain the fuel tank or place a piece of plastic beneath the cap to prevent gasoline leakage.
- Place shift lever in the first position and tip the mower on its side with air filter facing up.
- Remove the center bolt which secures the blade to the crankshaft followed by blade bell support, blade, and blade adapter.

- Move the cutting height adjustment to the highest position.
- Remove the three hex screws holding the baffle to the deck and pivot baffle towards the rear of the mower. See Figure 16.

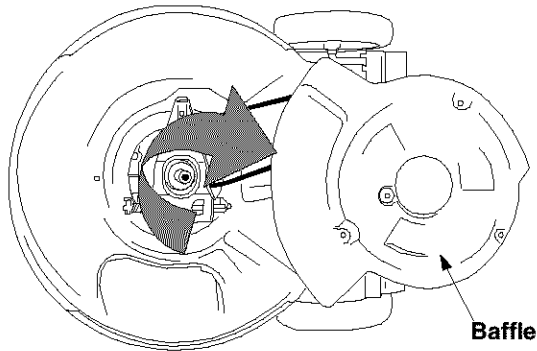

Figure 16

- Remove the hex bolt from the rear of unit holding the transmission to the mower housing. See Figure 17.

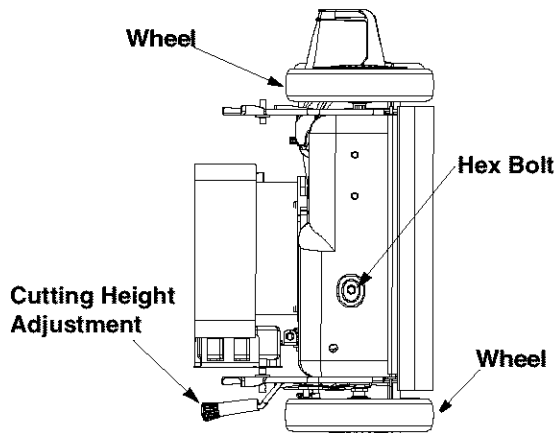

Figure 17

- Tilt the transmission forward and loosen the idler pulley bolt and lock nut half a turn. See Figure 18.

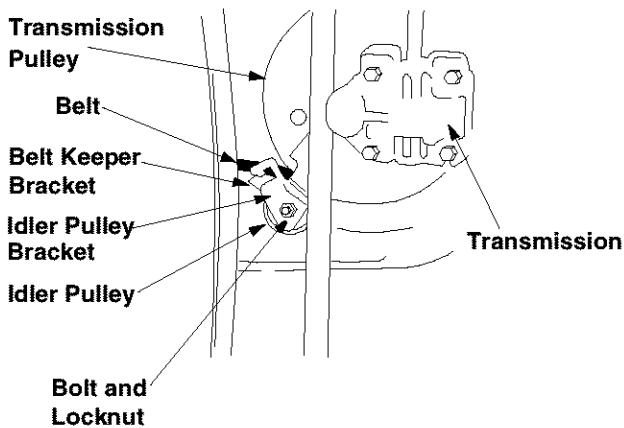

Figure 18

- Using a pair of pliers, pull back and rotate belt keeper bracket from the slot on the idler pulley.

- Slide the belt out from between the belt keeper bracket and the idler pulley. See Figure 18.
- Squeeze the belt together and push it forward, while pressing the control arm inward towards the deck and remove the three speed cable from the slot. See Figure 19.

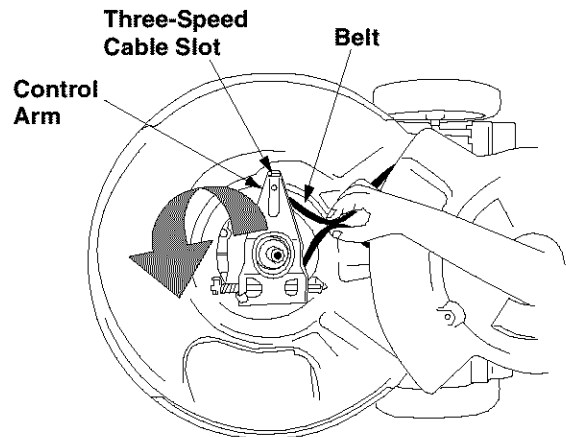

Figure 19

- Pivot the control arm down away from the pulley and belt.
- Lift off the lower pulley assembly and remove the old belt from around the crankshaft.
- Place the new belt over the transmission pulley. Start the belt in the pulley groove and rotate the pulley until the belt is seated in the transmission pulley.
- Place the belt between the idler pulley and the belt keeper bracket.
- Using pliers, rotate the belt keeper bracket so that it snaps into slot on the idler bracket.
- Tighten the idler pulley bolt and lock nut half a turn.
- Place the belt between the two pulley halves on the crankshaft. Make sure to route the belt inside the belt guard pin. See Figure 20.

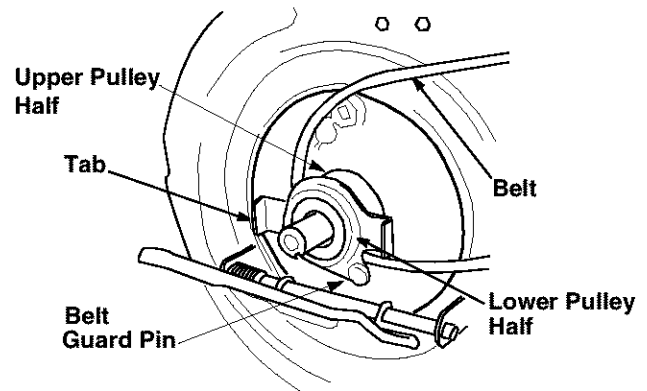

Figure 20

IMPORTANT: When replacing the belt, do not disassemble the lower pulley assembly.

- Pinch both sides of the belt together so that the belt is not in the pulley groove, and the lower pulley can be pushed towards the engine. See Figure 21.

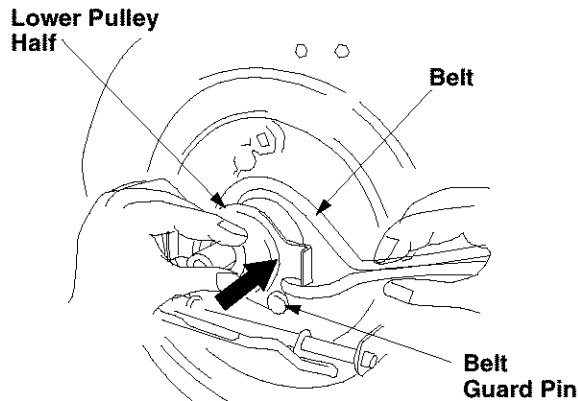

Figure 21

- Pivot the control arm back to its original position and reinstall the three-speed cable into the slot. See Figure 22.

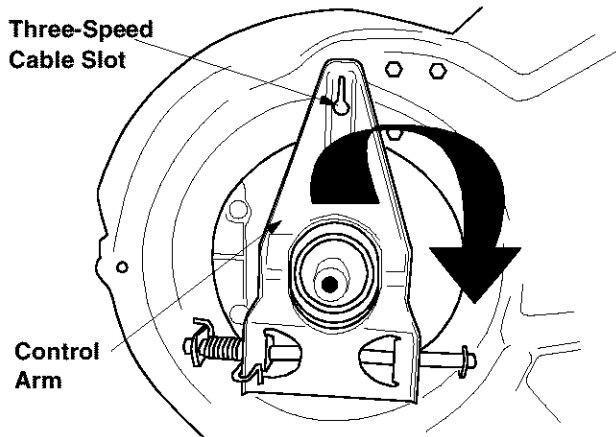

Figure 22

- Make sure the belt is routed inside the pulley halves and the belt guard pin.
- Reinstall the bolt securing transmission to rear mower housing.
- Pivot the baffle back to its original position and secure with three hex screws removed earlier.
- Lightly lubricate the inside of the blade adapter and reinstall the spacer, wave washer, blade adapter assembly, and blade in the correct order.
- Tighten the hex bolt to secure the blade to torque: 450-600 in. lbs.

Replacing Rear Flap

- To remove rear flap, cut off the flat end of the wire rod which secures it to the deck.
- Attach the new flap and new rod to deck, bending the ends of the new rod over to secure to deck.

SECTION 9: OFF-SEASON STORAGE

Storing Your Lawn Mower

The following steps should be taken to prepare your lawn mower for storage.

- Clean and lubricate mower thoroughly as described in the lubrication instructions.

IMPORTANT: We do not recommend the use of a pressure washer or garden hose to clean your unit.

- Refer to engine manual for correct engine storage instructions.

- Coat mower's cutting blade with chassis grease to prevent rusting.
- Store mower in a dry, clean area. Do not store next to corrosive materials, such as fertilizer.

NOTE: When storing any type of power equipment in a poorly ventilated or metal storage shed, care should be taken to rust-proof the equipment. Using a light oil or silicone, coat the equipment, especially cables and all moving parts.

SECTION 10: TROUBLESHOOTING

Problem	Cause	Remedy
Engine fails to start	<ol style="list-style-type: none"> 1. Blade control handle disengaged. 2. Spark plug wire disconnected. 3. Fuel tank empty or stale fuel. 4. Blocked fuel line. 5. Faulty spark plug. 6. Engine flooded 	<ol style="list-style-type: none"> 1. Engage blade control handle. 2. Connect wire to spark plug. 3. Fill tank with clean, fresh gasoline. 4. Clean fuel line. 5. Clean, adjust gap, or replace. 6. Wait a few minutes to restart, do not prime.
Engine runs erratic	<ol style="list-style-type: none"> 1. Spark plug wire loose. 2. Blocked fuel line or stale fuel. 3. Vent in gas plugged. 4. Water or dirt in fuel system. 5. Dirty air cleaner. 6. Carburetor out of adjustment. 	<ol style="list-style-type: none"> 1. Connect and tighten spark plug wire. 2. Clean fuel line; fill tank with clean, fresh gasoline 3. Clear vent. 4. Drain fuel tank. Refill with fresh fuel. 5. Clean air cleaner. 6. Adjust carburetor.
Engine overheats	<ol style="list-style-type: none"> 1. Engine oil level low. 2. Air flow restricted. 3. Carburetor not adjusted properly. 	<ol style="list-style-type: none"> 1. Fill crankcase with proper oil. 2. Remove blower housing and clean. 3. Adjust carburetor.
Occasional skip (hesitates) at high speed	<ol style="list-style-type: none"> 1. Spark plug gap too close. 	<ol style="list-style-type: none"> 1. Adjust gap to .030".
Idles poorly	<ol style="list-style-type: none"> 1. Spark plug fouled, faulty or gap too wide. 2. Carburetor improperly adjusted. 3. Dirty air cleaner. 	<ol style="list-style-type: none"> 1. Reset gap to .030" or replace spark plug. 2. Adjust carburetor. 3. Clean air cleaner.
Excessive vibration	<ol style="list-style-type: none"> 1. Cutting blade loose or unbalanced. 2. Bent cutting blade. 	<ol style="list-style-type: none"> 1. Tighten blade and adapter. Balance blade. 2. Replace blade.
Mower will not mulch grass	<ol style="list-style-type: none"> 1. Wet grass. 2. Excessively high grass. 3. Dull blade. 	<ol style="list-style-type: none"> 1. Do not mow when grass is wet; wait until later to cut. 2. Mow once at a high cutting height, then mow again at desired height or make a narrower cutting path. 3. Sharpen or replace blade.
Uneven cut	<ol style="list-style-type: none"> 1. Wheels not positioned correctly. 2. Dull blade. 	<ol style="list-style-type: none"> 1. Place all four wheels in same height position. 2. Sharpen or replace blade.

YOUR NOTES

Date	Comments

Safety & Decorative Labels

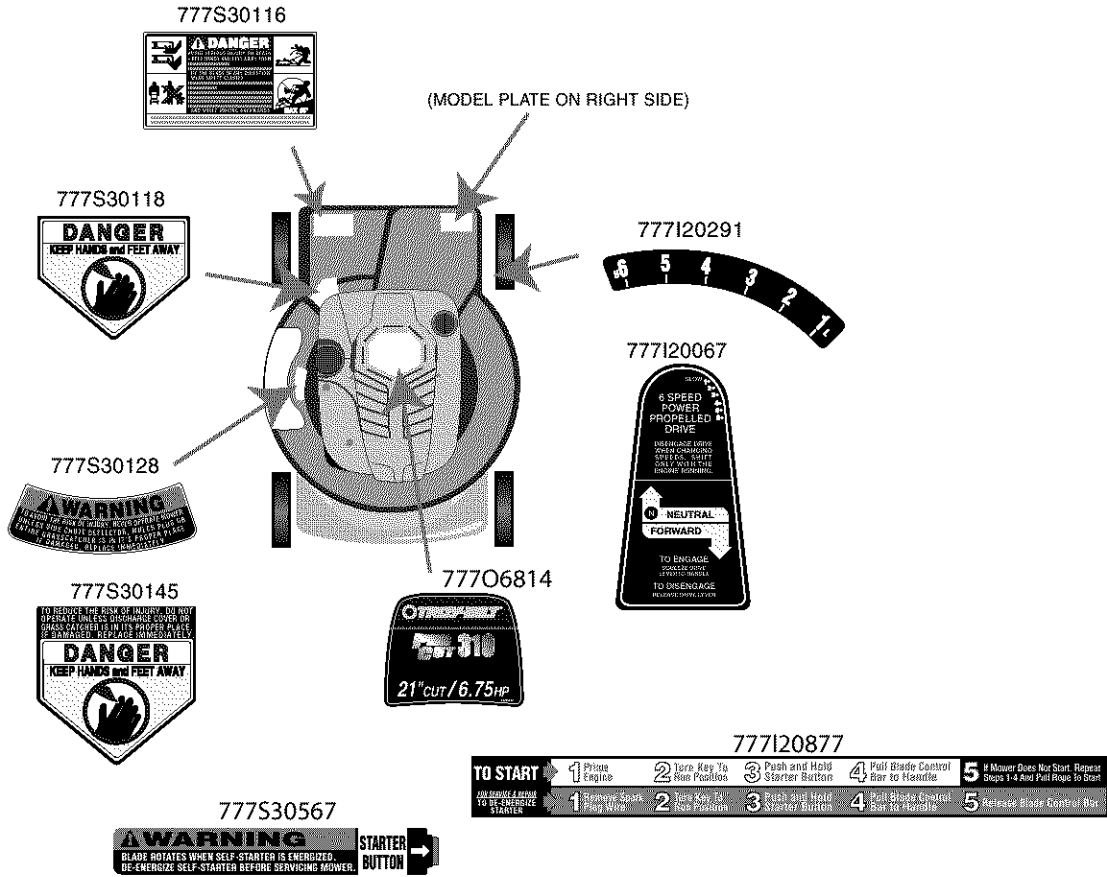

SECTION 11: PARTS LIST FOR MODEL S979

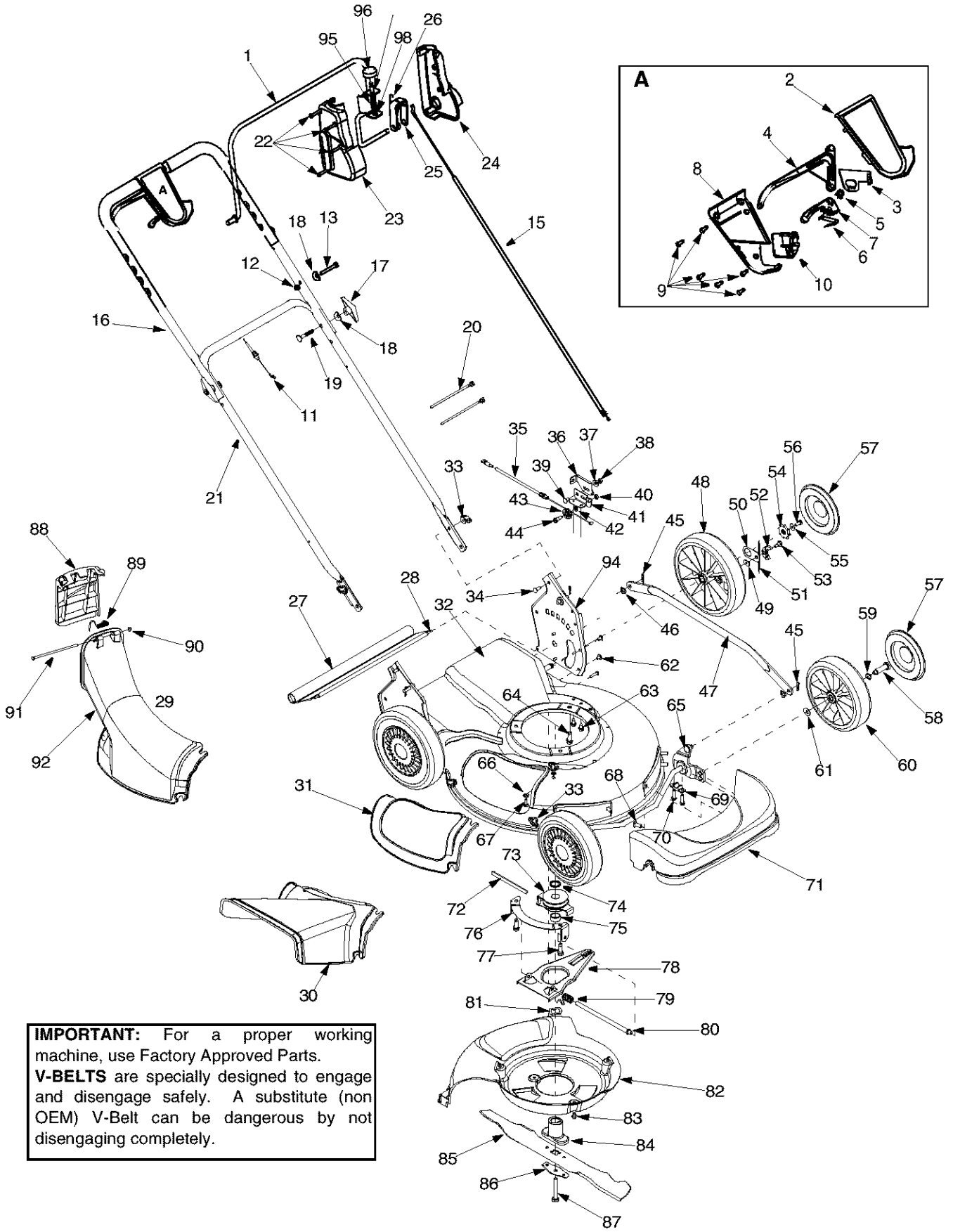

IMPORTANT: For a proper working machine, use Factory Approved Parts. **V-BELTS** are specially designed to engage and disengage safely. A substitute (non OEM) V-Belt can be dangerous by not disengaging completely.

Model S979

Ref. No.	Part No.	Description	Ref. No.	Part No.	Description
1.	647-0070	Control Handle	50.	16855	Ratchet Pawl Plate
-	731-2623	Bail Cover (Not shown)	51.	10622B	Plastic Spring Ratchet
2.	731-0904A	Upper Control Handle	52.	748-0381	Pawl RH
3.	16864	6 Spd. Rack Cable Bracket		748-0188B	Pawl LH
4.	731-0620	Control Lever	53.	738-0137A	Shld Screw .340 ID x .285 OD
5.	713-0397	Gear Insert	54.	748-0318	Wheel Ratchet
6.	732-0627	Shift Lever Spring	55.	736-0270	Bell Washer .265 ID x .75 OD
7.	731-0924	6 Speed Shift Lever	56.	710-0751	Hex Cap Screw 1/4-20 x .620
8.	731-0905A	Lower Control Housing	57.	731-0981A	Hubcap
9.	710-1667A	C Sunk Tap Screw #10 x .75 Lg	58.	738-0102	Shoulder Screw .498 x 1.445
10.	731-0906	Cable Mounting Cap	59.	736-0504	Wave Washer .510 ID x .750 OD
11.	746-0711A	Drive Cable 51.0	60.	734-2004A	Wheel 8 x 2
12.	712-0324	Hex Lock Nut 1/4-20 Gr. 8	61.	736-0105	Spring Washer .401 ID x .870 OD
13.	710-0501	Hex Hd. Cap Screw 1/4-20 Gr. 5	62.	710-1348	Screw 1/4-14 x .500
14.	710-1270	Oval C-Sunk Screw	63.	710-0896	Screw 1/4-14 x .625
15.	746-1141	Control Cable 58.25"	64.	710-0654A	Hex Washer Screw 3/8-16 x 1.0
16.	749-1405A	Upper Handle	65.	611-0064	Front Axle Assembly
17.	720-0284	Wing Nut	66.	736-0204	Flat Washer .344 ID x .62 OD
18.	736-0451	Saddle Washer .320 ID x .830 OD	67.	710-0703	Carriage Screw 1/4-20 x .75
19.	710-1174	Carriage Bolt 5/16-18 x 2.0	68.	710-1242	Torx Screw
20.	726-0240	Cable Tie	69.	741-0492A	Block Bushing
21.	749-0907B	Lower Handle	70.	710-1241	Hex Washer Screw
22.	710-1256	Hi-Low Screw	71.	731-1836	Front Axle Cover
23.	731-2533	Control Cover RH	72.	754-0460	Belt 3/8 x 39.24
24.	731-2532	Control Cover LH	73.	656-0613	Pulley Assembly
25.	782-0156	Lever	74.	750-1071	Sleeve Spacer .88 ID x 1.13 OD
26.	732-1172	Torsion Spring	75.	750-1070	Sleeve Spacer .88 ID x 1.00 OD
27.	731-1901	Trail Shield	76.	782-7597	Pivot Bracket
28.	732-0842	Trail Shield Wire	77.	710-0654A	Screw 3/8-18 x 1.0
29.	631-0066	Chute Assembly	78.	782-7596	Control Arm
30.	731-1832	Side Discharge Chute	79.	732-0807	Torsion Spring
31.	731-1833	Mulch Cover	80.	711-1114	Pivot Shaft
32.	782-0078B	Deck 21"	81.	736-0526	Wave Washer 1.38 ID x .88 OD
33.	712-0397	Wing Nut	82.	731-1828	Baffle
34.	710-0703	Carriage Bolt 1/4-20 x .75	83.	710-0653	Screw 1/4-20 x 3.75
35.	746-0939	6 Speed Cable	84.	753-0609	Blade Adapter Kit
36.	782-7574A	Cable Adjustment Bracket	85.	742-0741	21" Mulching Blade
37.	736-0270	Bell Washer .265 ID x .75 OD	86.	736-0524A	Blade Bell Support
38.	712-0287	Hex Nut 1/4-20	87.	710-1257	Hex Bolt 3/8-24 x 2.5
39.	710-0167	Carriage Screw 1/4-20 x .50	88.	731-1874	Chute Door
40.	712-0138	Hex Nut 1/4-28	89.	732-0819	Torsion Spring
41.	782-7575A	Cable Mounting Bracket	90.	726-0111	Push Cap
42.	736-0329	Lock Washer 1/4	91.	747-0965	Pivot Rod
43.	756-0625	Roller Cable	92.	731-1713B	Discharge Chute
44.	738-0924	Shoulder Screw .375 ID x 1/4-14	94.	682-3052	Handle Bracket Assembly - RH
45.	714-0104	Cotter Pin		682-3053	Handle Bracket Assembly - LH
46.	736-0286	Bowed Washer	95.	732-1171	Compression Spring
47.	782-0565	Single Lever Control Arm	96.	720-0428	Button
48.	734-2044	Wheel 9 x 2	97.	715-0168	Pin
49.	712-0414	Top Lock Tab Weld Nut 1/4-20			

Model S979

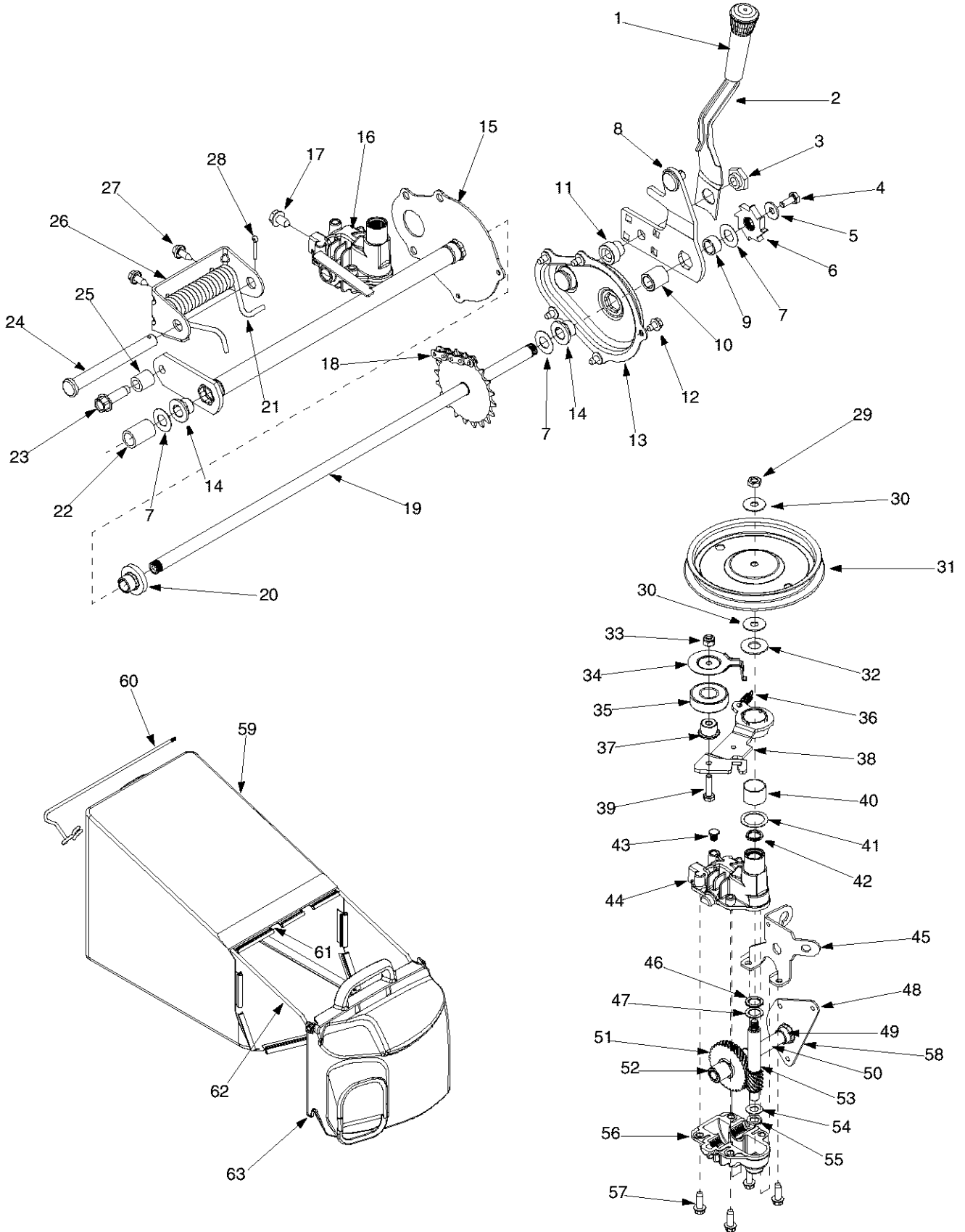

Model S979

Ref. No.	Part No.	Part Description	Ref. No.	Part No.	Part Description
1.	720-0223	Grip	33.	712-0896	Hex Jam Nut 1/4-28
2.	732-0803A	Spring Lever	34.	782-7598	Belt Keeper
3.	738-0529	Shoulder Nut .825 x .165 Lg.	35.	741-0600	Bearing
4.	710-0751	Cap Screw 1/4-20 x .620	36.	732-0849A	Extension Spring
5.	736-0270	Bell Washer .285 ID x .75 OD	37.	750-1050	Flange Spacer
6.	748-0318	Wheel Ratchet	38.	682-0027A	Idler Bracket Assembly
7.	736-0369	Flat Washer .508 ID x 1.0 OD	39.	710-0299	Hex Cap Screw 1/4-28 x 1.0
8.	682-0531	Pivot Arm Assembly	40.	741-0682A	Bearing Sleeve
9.	750-0515	Spacer .510 ID x .70 OD	41.	736-0570	Flat Washer .885 ID x 1.45 OD
10.	741-0978	Sleeve Bearing .504 ID x .830 OD	42.	721-0329	Oil Seal
11.	750-1056	Shoulder	43.	721-0325	Plug
12.	710-0653	Tap Screw 1/4-20 x .375	44.	618-0253	Upper Housing Assembly
13.	682-7528	Chain Cover Assembly	45.	782-7601A	Cable Bracket
14.	741-0324	Flange Bearing .506 ID x .590 Lg	46.	741-0690	Bearing
15.	682-7526	Transmission Axle Assembly	47.	736-0616	Thrust Washer .504 ID x .70 OD
16.	618-0263A	Transmission Assembly Complete	48.	782-7595	Pivot Bracket
17.	710-0604A	Hex Screw 5/16-18	49.	741-0324	Flange Bearing
18.	713-0453	Chain	50.	711-1168	Output Shaft 6T
19.	638-0012	Rear Axle Assembly	51.	717-1469	Gear 34T
20.	741-0522	Flange Bearing .506 ID x .715 Lg	52.	741-0674	Bearing
21.	732-0832	Torsion Spring	53.	717-1487	Pinion Shaft 10T
22.	750-0151	Spacer .550 ID x .750 OD	54.	736-0314	Thrust Washer 3/8 x .70
23.	710-1315	Screw 3/8-16 x .25	55.	736-0569	Thrust Washer .388 x .625
24.	711-0835	Clevis Pin .50 Dia x 4.82 Lg.	56.	618-0252	Lower Housing Assembly
25.	750-0807	Spacer .385 ID x .624 OD	57.	710-0642	Hex Screw 1/2-20 x .75
26.	782-0568	Hgt Adjustment Spring Bracket	58.	611-0066	Shaft Assembly
27.	710-1652	Screw 1/4-14 x .825	59.	664-0182	Grassbag Assembly
28.	714-0474	Cotter Pin	60.	747-0940A	Support Rod w/ Rope Guide
29.	712-3025	Hex Jam Nut 5/16-24	61.	747-0939	Pivot Rod
30.	736-0425	Bell Washer .325 ID x .930 OD	62.	747-0937	Grassbag Frame
31.	756-0656	Pulley	63.	631-0071	Grassbag Cover
32.	736-3084	Flat Washer .510 ID x 1.120 OD			

MANUFACTURER'S LIMITED WARRANTY FOR:



The limited warranty set forth below is given by Troy-Bilt LLC with respect to new merchandise purchased and used in the United States, its possessions and territories.

Troy-Bilt LLC warrants this product against defects for a period of two (2) years commencing on the date of original purchase and will, at its option, repair or replace, free of charge, any part found to be defective in materials or workmanship. This limited warranty shall only apply if this product has been operated and maintained in accordance with the Operator's Manual furnished with the product, and has not been subject to misuse, abuse, commercial use, neglect, accident, improper maintenance, alteration, vandalism, theft, fire, water, or damage because of other peril or natural disaster. Damage resulting from the installation or use of any accessory or attachment not approved by Troy-Bilt LLC for use with the product(s) covered by this manual will void your warranty as to any resulting damage.

Normal wear parts or components thereof are subject to separate terms as follows: All normal wear parts or component failures will be covered on the product for a period of 90 days regardless of cause. After 90 days, but within the two year period, normal wear part failures will be covered ONLY IF caused by defects in materials or workmanship of OTHER component parts. Normal wear parts and components include, but are not limited to: batteries, belts, blades, blade adapters, grass bags, rider deck wheels, seats, snow thrower skid shoes, shave plates, auger spiral rubber, and tires.

HOW TO OBTAIN SERVICE: Warranty service is available, WITH PROOF OF PURCHASE, through your local authorized service dealer. To locate the dealer in your area, check your Yellow Pages, or contact Troy-Bilt LLC at P.O. Box 361131, Cleveland, Ohio 44136-0019, or call 1-866-840-6483 or 1-330-558-7220, or log on to our Web site at www.troybilt.com.

This limited warranty does not provide coverage in the following cases:

- a. The engine or component parts thereof. These items carry a separate manufacturer's warranty. Refer to applicable manufacturer's warranty for terms and conditions.
- b. Log splitter pumps, valves, and cylinders have a separate one year warranty.
- c. Routine maintenance items such as lubricants, filters, blade sharpening, tune-ups, brake adjustments, clutch adjustments, deck adjustments, and normal deterioration of the exterior finish due to use or exposure.
- d. Troy-Bilt LLC does not extend any warranty for products sold or exported outside of the United States, its possessions and territories, except those sold through Troy-Bilt LLC's authorized channels of export distribution.
- e. Parts that are not genuine Troy-Bilt parts are not covered by this warranty.
- f. Service completed by someone other than an authorized service dealer is not covered by this warranty.
- g. Transportation charges and service calls are not covered.

No implied warranty, including any implied warranty of merchantability of fitness for a particular purpose, applies after the applicable period of express written warranty above as to the parts as identified. No other express warranty, whether written or oral, except as mentioned above, given by any person or entity, including a dealer or retailer, with respect to any product, shall bind Troy-Bilt LLC. During the period of the warranty, the exclusive remedy is repair or replacement of the product as set forth above.

The provisions as set forth in this warranty provide the sole and exclusive remedy arising from the sale. Troy-Bilt LLC shall not be liable for incidental or consequential loss or damage including, without limitation, expenses incurred for substitute or replacement lawn care services or for rental expenses to temporarily replace a warranted product.

Some states do not allow the exclusion or limitation of incidental or consequential damages, or limitations on how long an implied warranty lasts, so the above exclusions or limitations may not apply to you.

In no event shall recovery of any kind be greater than the amount of the purchase price of the product sold.

Alteration of safety features of the product shall void this warranty. You assume the risk and liability for loss, damage, or injury to you and your property and/or to others and their property arising out of the misuse or inability to use the product.

This limited warranty shall not extend to anyone other than the original purchaser or to the person for whom it was purchased as a gift.

HOW STATE LAW RELATES TO THIS WARRANTY:

This limited warranty gives you specific legal rights, and you may also have other rights which vary from state to state.

Troy-Bilt LLC, P.O. BOX 361131 CLEVELAND, OHIO 44136-0019; Phone: 1-866-840-6483, 1-330-558-7220