

# OPERATOR'S MANUAL

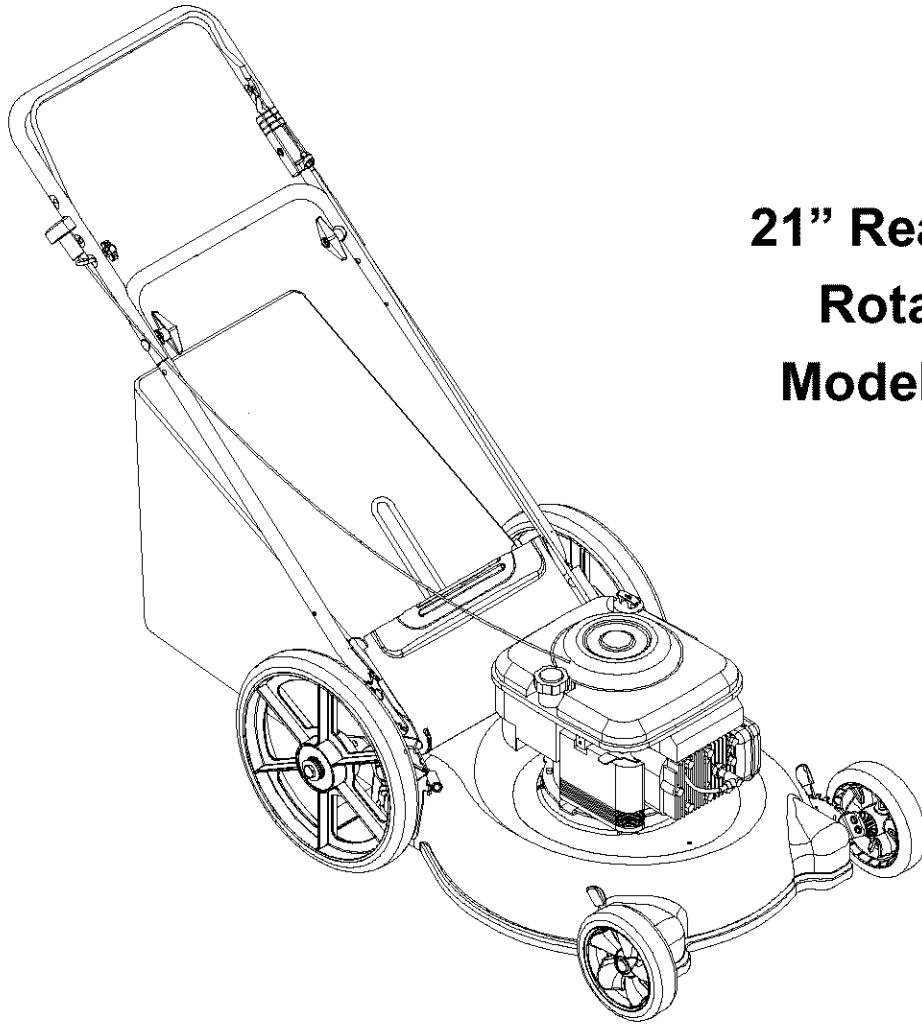

## 21" Rear Discharge Rotary Mower Model Series 580

### **IMPORTANT: READ SAFETY RULES AND INSTRUCTIONS CAREFULLY**

**Warning:** This unit is equipped with an internal combustion engine and should not be used on or near any unimproved forest-covered, brush-covered or grass-covered land unless the engine's exhaust system is equipped with a spark arrester meeting applicable local or state laws (if any). If a spark arrester is used, it should be maintained in effective working order by the operator. In the State of California the above is required by law (Section 4442 of the California Public Resources Code). Other states may have similar laws. Federal laws apply on federal lands. A spark arrester for the muffler is available through your nearest engine authorized service dealer or contact the service department, P.O. Box 361131 Cleveland, Ohio 44136-0019.

**MTD LLC, P.O. BOX 361131 CLEVELAND, OHIO 44136-0019**

PRINTED IN U.S.A.

FORM NO. 770-10113E  
(11/2001)

## TABLE OF CONTENTS

Content	Page
Important Safe Operation Practices.....	3
Slope Gauge.....	6
Assembling Your Lawn Mower.....	7
Know Your Lawn Mower .....	9
Operating Your Lawn Mower .....	9
Making Adjustments .....	11
Maintaining Your Lawn Mower.....	11
Troubleshooting.....	14
Parts List.....	16

## FINDING MODEL NUMBER

This Operator's Manual is an important part of your new lawn mower. It will help you assemble, prepare and maintain the unit for best performance. Please read and understand what it says.



**Before you start assembling your new equipment**, please locate the model plate on the equipment and copy the information from it in the space provided below. The information on the model plate is very important if you need help from our Customer Support Department or an authorized dealer.

- You can locate the model number by looking down at the rear of the deck. A sample model plate is explained below. For future reference, please copy the model number and the serial number of the equipment in the space below.



Copy the model number here: \_\_\_\_\_

Copy the serial number here: \_\_\_\_\_

## ENGINE INFORMATION

The engine manufacturer is responsible for all engine-related issues with regards to performance, power-rating, specifications, warranty and service. Please refer to the engine manufacturer's Owner's/Operator's Manual packed separately with your unit for more information.

## CALLING CUSTOMER SUPPORT

If you have difficulty assembling this product or have any questions regarding the controls, operation or maintenance of this unit, please call the Customer Support Department.



Call **1-(330) 220-4MTD (4683)** or **1-(800)-800-7310** to reach a Customer Support representative. Please have your unit's model number and serial number ready when you call. See previous section to locate this information. You will be asked to enter the serial number in order to process your call.

For more details about your unit, visit our website at [www.mtdproducts.com](http://www.mtdproducts.com)

---

## SECTION 1: IMPORTANT SAFE OPERATION PRACTICES



**WARNING:** This symbol points out important safety instructions which, if not followed, could endanger the personal safety and/or property of yourself and others. Read and follow all instructions in this manual before attempting to operate this machine. Failure to comply with these instructions may result in personal injury. When you see this symbol - **heed its warning.**

**WARNING:** Engine Exhaust, some of its constituents, and certain vehicle components contain or emit chemicals known to State of California to cause cancer and birth defects or other reproductive harm.

**DANGER:** This machine was built to be operated according to the rules for safe operation in this manual. As with any type of power equipment, carelessness or error on the part of the operator can result in serious injury. This machine is capable of amputating hands and feet and throwing objects. Failure to observe the following safety instructions could result in serious injury or death.

### General Operation

1. Read this operator's manual carefully in its entirety before attempting to assemble this machine. Read, understand, and follow all instructions on the machine and in the manual(s) before operation. Be completely familiar with the controls and the proper use of this machine before operating it. Keep this manual in a safe place for future and regular reference and for ordering replacement parts.
2. This machine is a precision piece of power equipment, not a plaything. Therefore, exercise extreme caution at all times. Your unit has been designed to perform one job: to mow grass. Do not use it for any other purpose.
3. Never allow children under 14 years old to operate this machine. Children 14 years old and over should read and understand the operation instructions and safety rules in this manual and should be trained and supervised by a parent. Only responsible individuals who are familiar with these rules of safe operation should be allowed to use this machine.
4. Thoroughly inspect the area where the equipment is to be used. Remove all stones, sticks, wire, bones, toys and other foreign objects which could be tripped over or picked up and thrown by the blade. Thrown objects can cause serious personal injury. Plan your mowing pattern to avoid discharge of material toward roads, sidewalks, bystanders and the like. Also, avoid discharging material against a wall or obstruction which may cause discharged material to ricochet back toward the operator.
5. To help avoid blade contact or a thrown object injury, stay in the operator zone behind the handles and keep children, bystanders, helpers and pets at least 75 feet from the mower while it is in operation. Stop machine if anyone enters the area.
6. Always wear safety glasses or safety goggles during operation and while performing an adjustment or repair to protect your eyes. Thrown objects which ricochet can cause serious injury to the eyes.
7. Wear sturdy, rough-soled work shoes and close-fitting slacks and shirts. Shirts and pants that cover the arms and legs and steel-toed shoes are recommended. Never operate this machine in bare feet, sandals, slippery or light weight (e.g. canvas) shoes.
8. Do not put hands or feet near rotating parts or under the cutting deck. Contact with the blade can amputate hands and feet.
9. A missing or damaged discharge cover can cause blade contact or thrown object injuries.
10. Many injuries occur as a result of the mower being pulled over the foot during a fall caused by slipping or tripping. Do not hold on to the mower if you are falling; release the handle immediately.
11. Never pull the mower back toward you while you are walking. If you must back the mower away from a wall or obstruction first look down and behind to avoid tripping and then follow these steps:
  - a. Step back from the mower to fully extend your arms.
  - b. Be sure you are well balanced with sure footing.
  - c. Pull the mower back slowly, no more than half way toward you.
  - d. Repeat these steps as needed.
12. Do not operate the mower while under the influence of alcohol or drugs.
13. Do not engage the self-propelled mechanism on units so equipped while starting engine.
14. The blade control handle is a safety device. Never attempt to bypass its operation. Doing so makes the safety device inoperative and may result in personal injury through contact with the rotating blade. The blade control handle must operate easily in both directions and automatically return to the disengaged position when released.
15. Never operate the mower in wet grass. Always be sure of your footing. A slip and fall can cause serious personal injury. If you feel you are losing your footing, release the blade control handle immediately and the blade will stop rotating within three seconds.
16. Mow only in daylight or in good artificial light. Walk, never run.
17. Stop the blade when crossing gravel drives, walks or roads.
18. If the equipment should start to vibrate abnormally, stop the engine and check immediately for the cause. Vibration is generally a warning of trouble.
19. Shut the engine off and wait until the blade comes to a complete stop before removing the grass catcher or

unclogging the chute. The cutting blade continues to rotate for a few seconds after the engine is shut off. Never place any part of the body in the blade area until you are sure the blade has stopped rotating.

20. Never operate mower without proper trail shield, discharge cover, grass catcher, blade control handle or other safety protective devices in place and working. Never operate mower with damaged safety devices. Failure to do so, can result in personal injury.
21. Muffler and engine become hot and can cause a burn. Do not touch.
22. Only use parts and accessories made for this machine by the manufacturer. Failure to do so, can result in personal injury.
23. If situations occur which are not covered in this manual, use care and good judgment. Contact your dealer for assistance. Telephone 1-800-800-7310 for the name of your nearest dealer.

## Slope Operation

Slopes are a major factor related to slip and fall accidents which can result in severe injury. Operation on slopes requires extra caution. If you feel uneasy on a slope, do not mow it. For your safety, use the slope gauge included as part of this manual to measure slopes before operating this unit on a sloped or hilly area. If the slope is greater than 15 degrees, do not mow it.

### Do:

1. Mow across the face of slopes; never up and down. Exercise extreme caution when changing direction on slopes.
2. Watch for holes, ruts, rocks, hidden objects, or bumps which can cause you to slip or trip. Tall grass can hide obstacles.
3. Always be sure of your footing. A slip and fall can cause serious personal injury. If you feel you are losing your balance, release the blade control handle immediately, and the blade will stop rotating within 3 seconds.

### Do Not:

1. Do not mow near drop-offs, ditches or embankments, you could lose your footing or balance.
2. Do not mow slopes greater than 15 degrees as shown on the slope gauge.
3. Do not mow on wet grass. Unstable footing could cause slipping.

## Children

Tragic accidents can occur if the operator is not alert to the presence of children. Children are often attracted to the mower and the mowing activity. They do not understand the dangers. Never assume that children will remain where you last saw them.

1. Keep children out of the mowing area and under the watchful care of a responsible adult other than the operator.
2. Be alert and turn mower off if a child enters the area.
3. Before and while moving backwards, look behind and down for small children.
4. Use extreme care when approaching blind corners, doorways, shrubs, trees, or other objects that may

obscure your vision of a child who may run into the mower.

5. Keep children away from hot or running engines. They can suffer burns from a hot muffler.
6. Never allow children under 14 years old to operate a power mower. Children 14 years old and over should read and understand the operation instructions and safety rules in this manual and should be trained and supervised by a parent.

## Service

### Safe Handling Of Gasoline:

1. To avoid personal injury or property damage use extreme care in handling gasoline. Gasoline is extremely flammable and the vapors are explosive. Serious personal injury can occur when gasoline is spilled on yourself or your clothes which can ignite.
2. Wash your skin and change clothes immediately.
3. Use only an approved gasoline container.
4. Never fill containers inside a vehicle or on a truck or trailer bed with a plastic liner. Always place containers on the ground away from your vehicle before filling.
5. When practical, remove gas-powered equipment from the truck or trailer and refuel it on the ground. If this is not possible, then refuel such equipment on a trailer with a portable container, rather than from a gasoline dispenser nozzle.
6. Keep the nozzle in contact with the rim of the fuel tank or container opening at all times until fueling is complete. Do not use a nozzle lock-open device.
7. Extinguish all cigarettes, cigars, pipes and other sources of ignition.
8. Never fuel machine indoors because flammable vapors will accumulate in the area.
9. Never remove gas cap or add fuel while the engine is hot or running. Allow engine to cool at least two minutes before refueling.
10. Never over fill fuel tank. Fill tank to no more than ½ inch below bottom of filler neck to provide space for fuel expansion.
11. Replace gasoline cap and tighten securely.
12. If gasoline is spilled, wipe it off the engine and equipment. Move unit to another area. Wait 5 minutes before starting the engine.
13. Never store the machine or fuel container inside where there is an open flame, spark or pilot light as on a water heater, space heater, furnace ,clothes dryer or other gas appliances.
14. To reduce fire hazard, keep mower free of grass, leaves, or other debris build-up. Clean up oil or fuel spillage and remove any fuel soaked debris.
15. Allow a mower to cool at least 5 minutes before storing.

### General Service:

1. Never run an engine indoors or in a poorly ventilated area. Engine exhaust contains carbon monoxide, an odorless and deadly gas.
2. Before cleaning, repairing, or inspecting, make certain the blade and all moving parts have stopped. Disconnect the spark plug wire and ground against the engine to prevent unintended starting.
3. Check the blade and engine mounting bolts at frequent

intervals for proper tightness. Also, visually inspect blade for damage (e.g., bent, cracked, worn) Replace blade with the original equipment manufacturer's (O.E.M.) blade only, listed in this manual. "Use of parts which do not meet the original equipment specifications may lead to improper performance and compromise safety!"

4. Mower blades are sharp and can cut. Wrap the blade or wear gloves, and use extra caution when servicing them.
5. Keep all nuts, bolts, and screws tight to be sure the equipment is in safe working condition.
6. Never tamper with safety devices. Check their proper operation regularly.
7. After striking a foreign object, stop the engine, disconnect the spark plug wire and ground against the engine. Thoroughly inspect the mower for any damage. Repair the damage before starting and operating the mower.
8. Never attempt to make a wheel or cutting height adjustment while the engine is running.
9. Grass catcher components, discharge cover, and trail shield are subject to wear and damage which could expose moving parts or allow objects to be thrown. For safety protection, frequently check components and replace immediately with original equipment manufacturer's (O.E.M.) parts only, listed in this manual. "Use of parts which do not meet the original equipment specifications may lead to improper performance and compromise safety!"
10. Do not change the engine governor setting or overspeed the engine. The governor controls the maximum safe operating speed of the engine.
11. Maintain or replace safety and instruction labels, as necessary.
12. Observe proper disposal laws and regulations. Improper disposal of fluids and materials can harm the environment.



**WARNING - YOUR RESPONSIBILITY:** Restrict the use of this power machine to persons who read, understand and follow the warnings and instructions in this manual and on the machine.

**NOTE:** Not all safety labels may apply to your lawn mower.



## SECTION 2: SLOPE GAUGE

Use this page as a guide to determine slopes where you may not operate safely. Do not operate your lawn mower on such slopes.

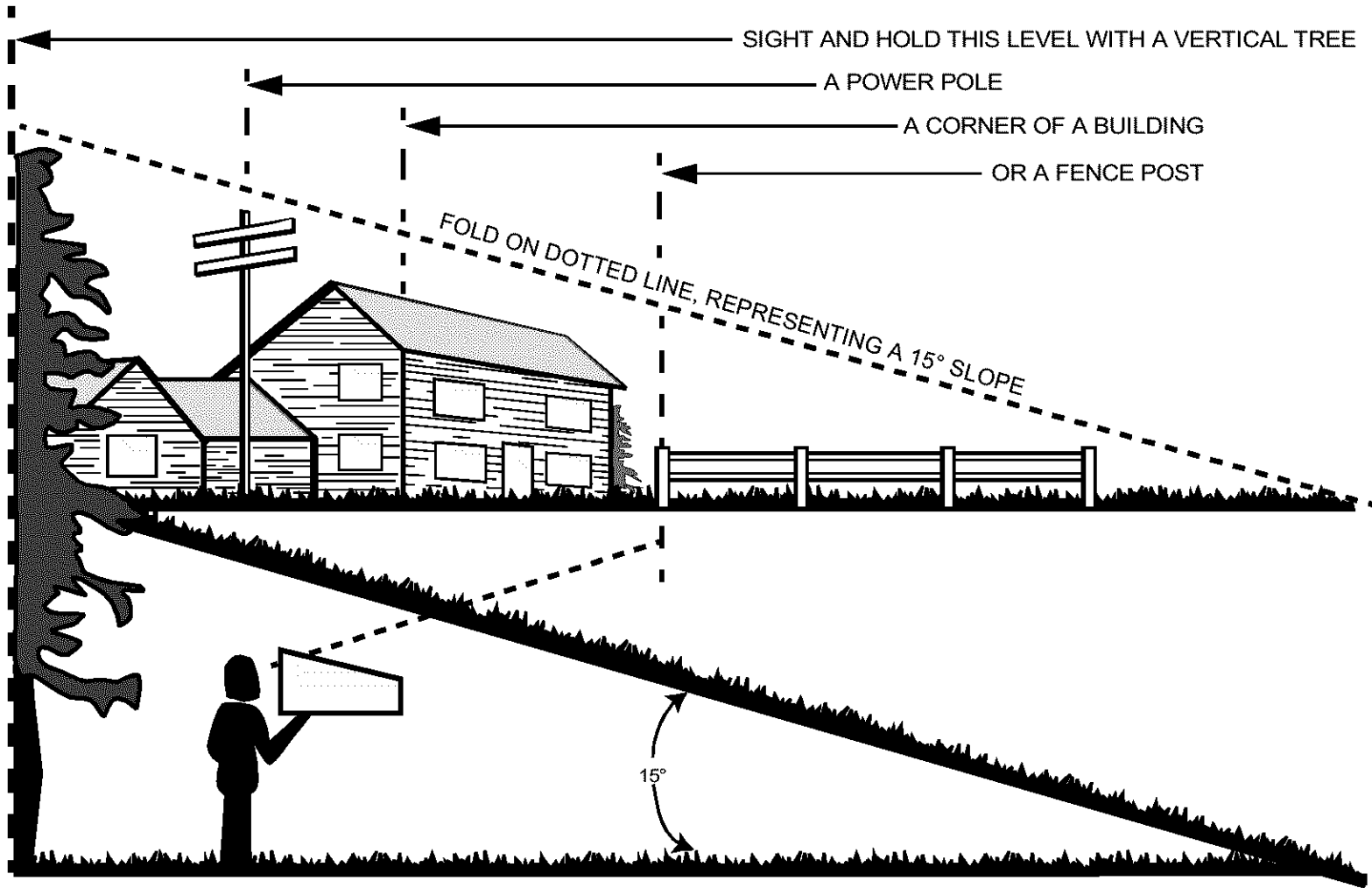

### WARNING

Do not mow on inclines with a slope in excess of 15 degrees (a rise of approximately 2-1/2 feet every 10 feet). A riding mower could overturn and cause serious injury. If operating a walk-behind mower on such a slope, it is extremely difficult to maintain your footing and you could slip, resulting in serious injury.

Operate RIDING mowers up and down slopes, never across the face of slopes.

Operate WALK-BEHIND mowers across the face of slopes, never up and down slopes.

## SECTION 3: ASSEMBLING YOUR LAWN MOWER

**IMPORTANT:** This unit is shipped without gasoline or oil in the engine. Be certain to service engine with gasoline and oil as instructed in the separate engine manual before operating your mower.

**NOTE:** Reference to right or left hand side of the mower is observed from the operating position.

### Removing Unit From Carton

- Remove staples, break glue on top flaps, or cut tape at carton end and peel along top flap to open carton.
- Remove loose parts if included with unit (i.e., operator's manual, etc.)
- Cut along corners, lay carton down flat, and remove packing material.
- Roll or slide unit out of carton and check carton thoroughly for loose parts.

### Disconnecting Spark Plug Wire

Before setting up your lawn mower, disconnect the spark plug wire from the spark plug and ground against the engine. See Figure 1.

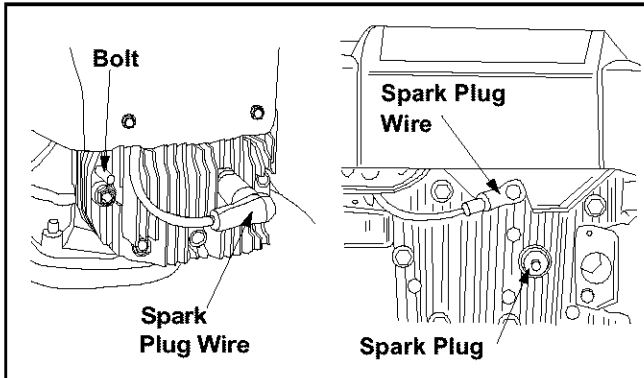

Figure 1

### Setting Up Your Lawn Mower

#### Assembling Handle

- Lift up and pull back on the upper handle to raise the handle into the operating position. Make certain the lower handle is seated securely into the handle bracket assemblies. Tighten the wing nuts on each side of the handle (carriage bolts must be seated properly into the handle). See Figure 2.

**NOTE:** Your mower is shipped with the handle in the higher position. If you wish to lower the height of the handle, refer to the Adjustment Section at this time.

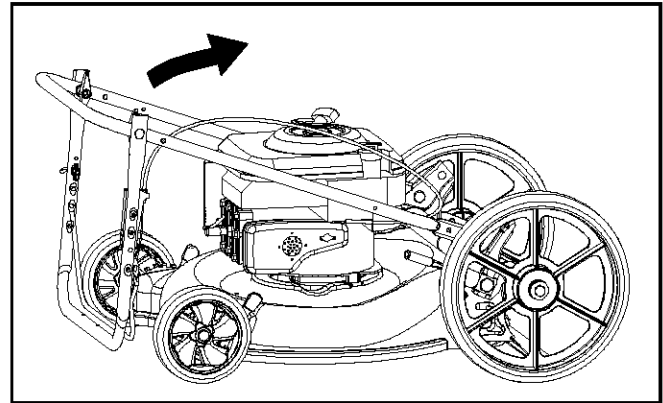

Figure 2

- Remove the hairpin clips from the outer hole in the weld pins on the handle mounting brackets. Using a pair of pliers, squeeze one leg of the lower handle against the handle mounting bracket. Insert the hairpin clip into the inner hole on the weld pin. Repeat on the other side. See Figure 3.
- After moving the hairpin clip, insert the carriage bolt from hardware pack in the upper hole on the handle mounting bracket and secure with plastic wing nut from the hardware pack. Repeat on other side.

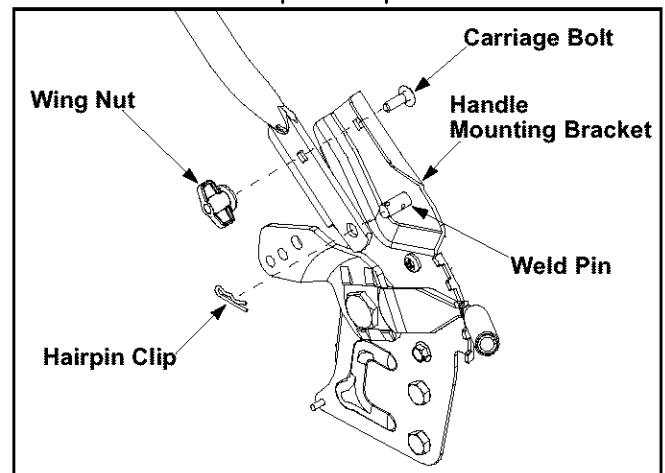

Figure 3

- Fasten the cable to the lower handle with the two cable ties found on the lower handle. Pull the cable ties tight and trim off the excess. See Figure 4.

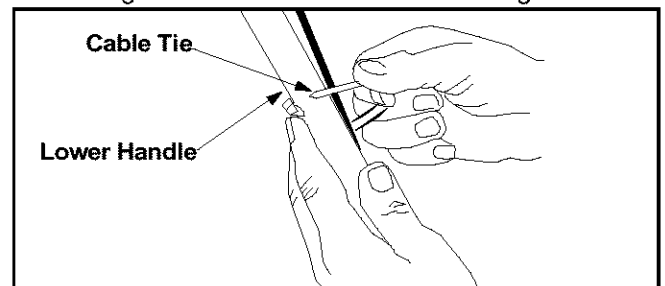

Figure 4

### Attaching Starter Rope

- The rope guide is attached to the right side of upper handle. Loosen the wing nut which secures the rope guide. See Figure 5.

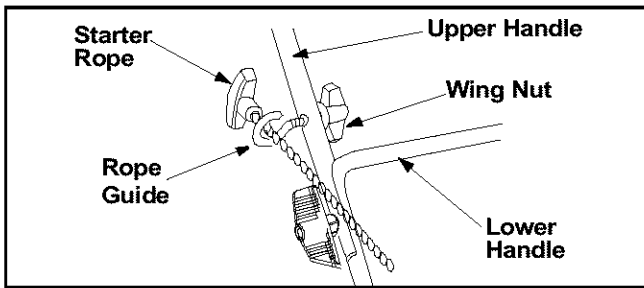

Figure 5

- With the spark plug wire disconnected and grounded, hold the blade control handle against the upper handle, and pull the starter rope out of the engine. Release the blade control handle. Slip the starter rope into the rope guide. Tighten the wing nut.

### Assembling Soft Top Grass Catcher

**NOTE:** If your mower's grass catcher has been already assembled before shipping, proceed to the next section. If it has been shipped not assembled, follow the steps below.

- Insert frame into grass bag with the black plastic side on the bottom of bag. See Figure 6.

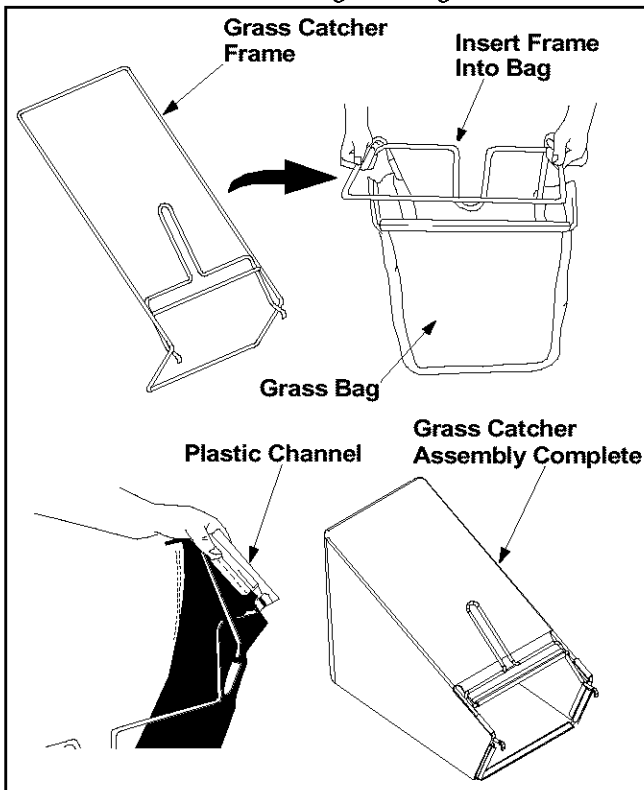

Figure 6

- Slip the openings in the side of the plastic channel on bag over the hooks on the grass catcher frame. Secure bag to the frame by working the six plastic channels on bag over frame. All the plastic channels attach from the outside of bag. See Figure 6.

### Attaching Grass Catcher To Mower

- Remove the mulching baffle in order to install and use the grass catcher. Lift the rear discharge door and remove the rear mulching baffle from the mower. See Figure 7.

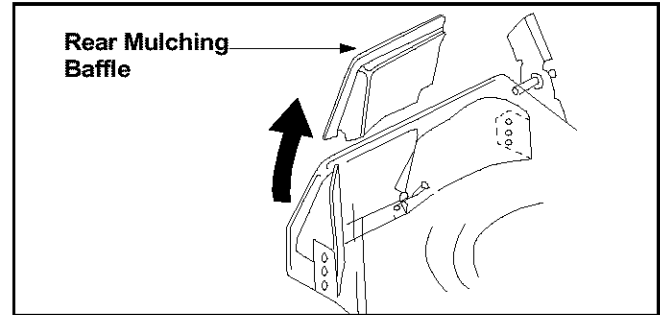

Figure 7

- Holding open the rear discharge door, place the grass catcher on the pivot rod. Let go of discharge door so that it rests on the grass catcher. See Figure 8.
- To remove the grass catcher, lift the rear discharge door on the mower and lift the grass catcher up. Reinstall the rear mulching baffle and release the rear discharge door.

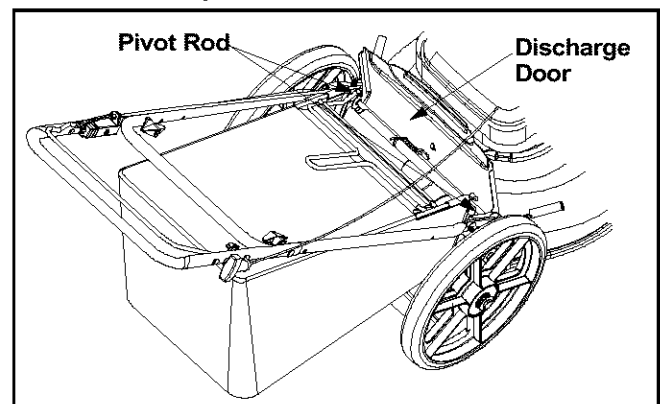

Figure 8



## SECTION 4: KNOW YOUR LAWN MOWER

Read this operator's manual and safety rules before operating your lawn mower. Compare the illustration in with your lawn mower to familiarize yourself with the location of various controls and adjustments. Save this manual for future reference.



**WARNING:** The operation of any lawn mower can result in foreign objects being thrown into the eyes, which can damage your eyes severely. Always wear safety glasses while operating the mower, or while performing any adjustments or repairs on it.

### Recoil Starter

The recoil starter is attached to the right handle. Stand behind the unit and pull the recoil starter to start the unit. See Figure 9.

### Blade Control Handle

The blade control handle is located on the upper handle of the mower. The blade control handle must be depressed in order to operate the unit. Release blade control handle to stop engine and blade. See Figure 9.



**WARNING:** This blade control mechanism is a safety device. Never attempt to bypass its operations.

### Height Adjustment Levers

These levers are located on each wheel and are used to adjust the cutting height. These levers have to be at the same relative position to ensure uniform cut. See Figure 9.

### Engine Controls

See the separate engine manual for additional information and functions of the engine controls.

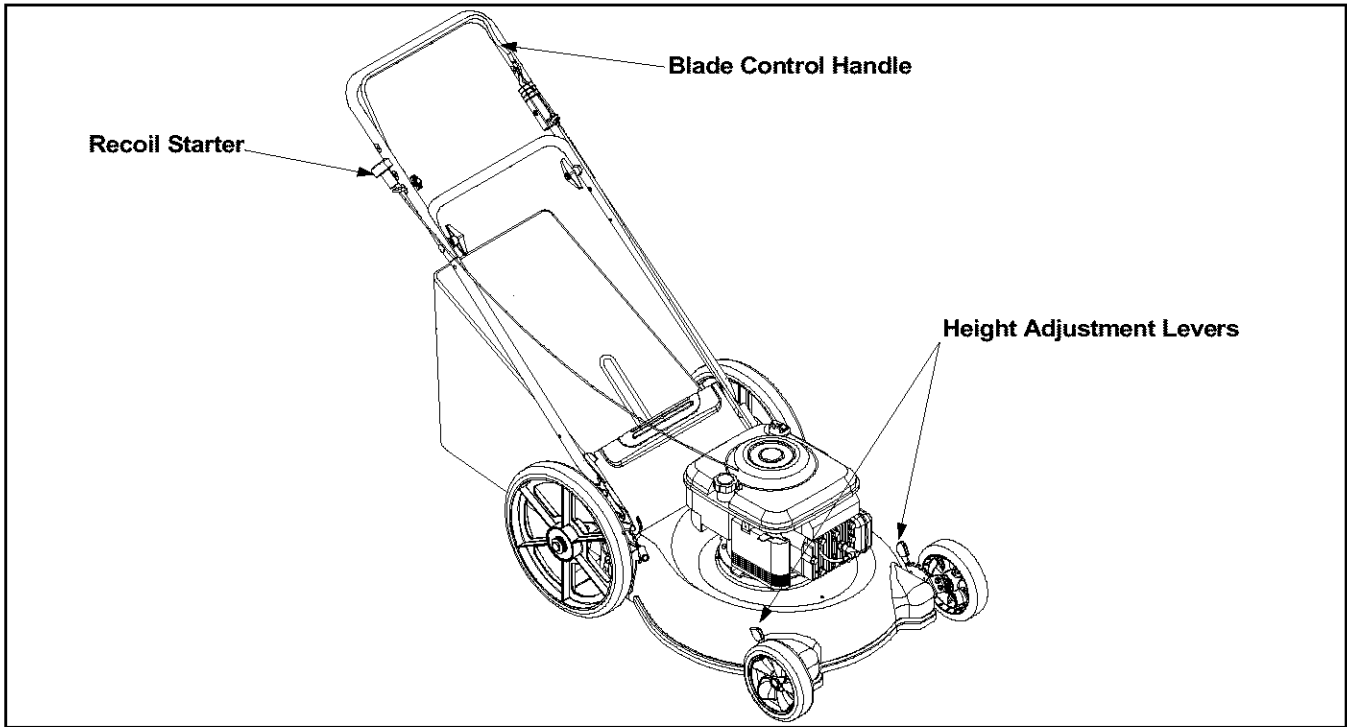

Figure 9

## SECTION 5: OPERATING YOUR LAWN MOWER



**WARNING:** Keep hands and feet away from chute area on the cutting deck. The operation of any lawn mower can result in foreign objects being thrown into the eyes, which can result in severe eye damage. Always wear safety glasses or eye shields.

### Gas and Oil Fill-Up

Service the engine with gasoline and oil as instructed in

the separate engine manual packed with your mower. Read instructions carefully.



**WARNING:** Never fill fuel tank indoors with engine running or until the engine has been allowed to cool for at least two minutes after running.

## Towards Better Mower Performance

1. Pour fresh, clean gasoline into the mower's gas tank until the tank is full. Do not use gasoline that is more than 30 days old.
2. Make sure to connect the mower's spark plug wire before trying to start the engine.
3. Add engine oil to the oil fill on the mower engine. Check the dipstick and add more if necessary. Remember that the oil level has to touch the fill line.
4. Locate the primer decal near the primer bulb on the engine, and read its instruction. Using your thumb, press the primer bulb slowly as many times as the decal advises.
5. Hold control handle down and pull rope firmly to start the engine.
6. Set cutting height adjustment lever to middle setting and mow a single pass on your lawn; then adjust to desired height for a closer cut.
7. To mulch insert the mulch plug/cover on the mower.
8. Before storing the lawn mower for the winter, use stabilizer-treated fuel and run the tank dry.
9. Thirty days before start of the new season, check the air filter, spark plug and blade on the lawn mower, and replace if needed.

**NOTE:** For shipping purposes your mower is set with the wheels in a low cutting height position. For best results raise the cutting position until it is determine which height is best for your lawn. See the Adjustment Section for details.

## Stopping Engine

- Release blade control handle to stop the engine and the blade.
- Disconnect spark plug wire and ground it to a bolt on the engine.

## Starting Engine

- Attach spark plug wire to spark plug. Make certain the metal cap on the end of the spark plug is fastened securely over the metal tip on the spark plug.
- Prime engine as instructed in the separate engine manual packed with your unit.
- Your lawn mower may be equipped with a constant speed throttle, which is set at full throttle for best performance.
- Stand behind the mower and squeeze the blade control handle against the upper handle.
- Grasp recoil starter handle and pull rope out slowly until engine reaches the start of compression cycle (rope will pull slightly harder at this point). Let the rope rewind slowly. Pull rope with a rapid, continuous, full arm stroke. Keeping a firm grip on the starter handle, let the rope return to the starter slowly.

## Using Your Lawn Mower

Be sure that the lawn is clear of stones, sticks, wire, or other objects which could damage the lawn mower or the engine. Such objects could be accidentally thrown by

the mower in any direction and cause serious personal injury to the operator and others.

For best results, do not cut wet grass because it tends to stick to the underside of the mower, preventing proper discharge of grass clippings, and could cause you to slip and fall. New grass, thick grass, or wet grass may require a narrower cut.

For a healthier lawn, never cut off more than one-third of the total length of the grass. Your lawn should be cut in the fall as long as there is growth. This mower is designed to be operated at full throttle to give you the best cut and do the most effective job of mowing or mulching.



**WARNING:** If you strike a foreign object, stop the engine. Remove wire from the spark plug, thoroughly inspect the mower for any damage, and repair the damage before restarting and operating the mower. Extensive vibration of the mower during operation is an indication of damage. The unit should be promptly inspected and repaired.

## Mulching

For effective mulching, do not cut wet grass because it tends to stick to the underside of the deck, preventing proper mulching of grass clippings. New or thick grass may require a narrower cut. The ground speed should be adjusted to the condition of the lawn. If mowing has been delayed and the grass has been allowed to grow in excess of 4", mulching is not recommended. Mow using the side discharge to reduce the grass height to 3 1/4" maximum before mulching.

---

## SECTION 6: MAKING ADJUSTMENTS



**WARNING:** Do not at any time make any adjustments without first stopping engine and disconnecting spark plug wire.

### Cutting Height Adjustment

An adjusting plate and spring lever at each wheel position provides cutting height adjustment. Each adjusting plate has assorted height positions. When the spring lever is moved from one location to another the height of cut will be changed. Simply depress the lever towards wheel and move lever assembly to desired position. See Figure 10.

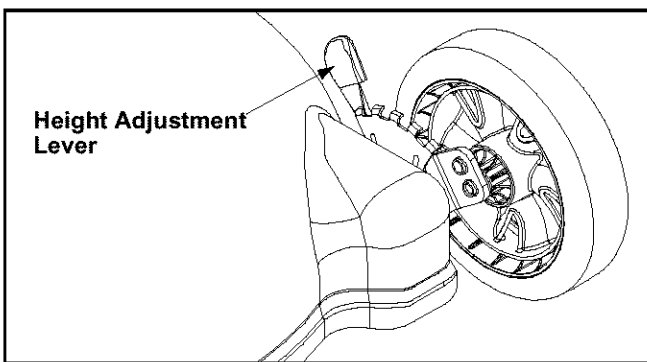

Figure 10

**IMPORTANT:** All wheels must be placed in the same relative position. For rough or uneven lawns, move the height adjustment lever to a higher position. This will help stop scalping of the grass.

### Handle Height Adjustment

Your mower is shipped with the handle in the higher height position. To lower the height proceed as follows:

- Remove the starter rope from the rope guide.
- Remove the upper handle by removing the hand knobs and carriage bolts. Lay the upper handle out of the way, being careful not to bend or kink the cables.
- Remove the hairpin clips from the weld pins on the handle brackets. Press out on the legs of the lower handle. Remove lower handle from the mower.
- Turn lower handle around so the notch on the bottom of the lower handle is facing forward. Reassemble, placing the bottom holes in the handle over the weld pins in the handle mounting bracket. See Figure 11.

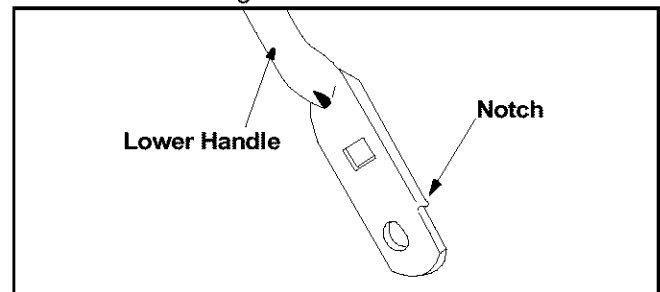

Figure 11

- Reassemble the upper handle to the lower handle.
- Place the hairpin clips in the inner holes in the weld pins and attach the starter rope as instructed in the Assembly Section.

---

## SECTION 7: MAINTAINING YOUR LAWN MOWER

### General Recommendations

- Always observe safety rules when performing any maintenance.
- The warranty on this lawn mower does not cover items that have been subjected to operator abuse or negligence. To receive full value from the warranty, operator must maintain the lawn mower as instructed in this manual.
- Changing of engine governed speed will void engine warranty.
- Some adjustments will have to be made periodically to maintain your unit properly. All adjustments in the Making Adjustments section of this manual should be checked at least once each season.
- Periodically check all fasteners and make sure these are tight.
- Follow the maintenance schedule under Customer Responsibilities to get quality performance from your lawn mower.

# Customer Responsibilities

MAINTENANCE SCHEDULE		After each use	Every 25 hours	Every 50 hours	Every 100 hours	Once a season	Before storage	SERVICE DATES					
PRODUCT	Lubricate Wheels					✓							
	Lubricate Blade Control					✓							
	Clean Deck	✓					✓						
	Blade Care		✓				✓						
ENGINE	Check Oil	✓											
	Change Oil		✓				✓						
	Replace Air Filter				✓								
	Clean Engine	✓					✓						
	Check Spark Plug			✓		✓							
	Check Spark Arrester (if any)			✓									

## Lubrication



Always stop engine and disconnect spark plug wire before cleaning, lubricating or doing any kind of service work on the lawn mower.

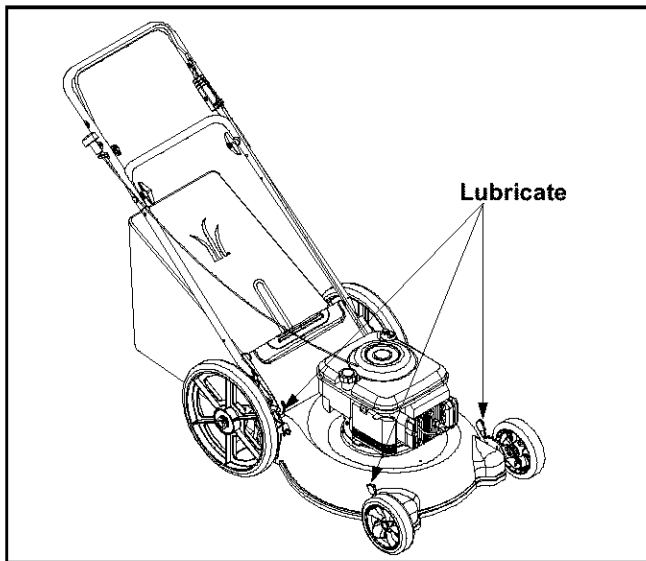

Figure 12

**Blade Control:** Lubricate the pivot points on the blade control handle at least once a season with light oil. The blade control must operate freely in both directions. See Figure 12.

**Wheels:** Lubricate the wheels at least once a season with light oil (or motor oil). If the wheels are removed for

any reason, lubricate the surface of the axle bolt and inner surface of the wheel with light oil. See Figure 12.

**Chute Deflector:** Lubricate the torsion springs and pivot points on chute deflector using light oil. This will insure the deflector, which is a safety device, can always work properly. See Figure 12.

**Engine:** Follow the separate engine manual packed with you unit for lubrication instructions.

## Maintenance

**NOTE:** When tipping the unit, empty the fuel tank and keep the spark plug side of engine up. Never tip the mower more than 90 degrees and do not leave the mower tipped for any length of time. Oil can drain into the upper part of the engine causing a starting problem.

### Engine

Refer to the separate engine manual for all engine maintenance instructions.

- Maintain engine oil as instructed in the separate engine manual packed with your unit.
- Service air cleaner every 25 hours under normal conditions. Poor engine performance and flooding usually indicate that the air cleaner should be serviced. To service the air cleaner, refer to the separate engine manual packed with your unit.
- The spark plug should be cleaned and the gap reset once a season. Spark plug replacement is recommended at the start of each mowing season.

Clean the engine regularly with a cloth or brush. Keep the cooling system (blower housing area) clean to permit proper air circulation which is essential to engine

performance and life. Be certain to remove all grass, dirt, and combustible debris from muffler area.

### Deck

The underside of the mower deck should be cleaned after each use to prevent a buildup of grass clippings, leaves, dirt, or other matter. If this debris is allowed to accumulate, it will invite rust and corrosion, and may prevent proper mulching, discharge, or bagging. The deck may be cleaned by tilting the mower and scraping clean with a suitable tool (make certain the spark plug wire is disconnected).

**IMPORTANT:** We do not recommend the use of a pressure washer or garden hose to clean your unit. The use of water will result in shorten life and reduce serviceability.

### Cutting Blade Removal, Replacement, and Sharpening

- When removing the cutting blade for sharpening or replacement, protect your hands with a pair of heavy gloves or use a heavy rag to hold the blade.
- Remove the bolt and the blade bell support which hold the blade and the blade adapter to the engine crankshaft. See Figure 12.
- Remove the blade and the adapter from the crankshaft.

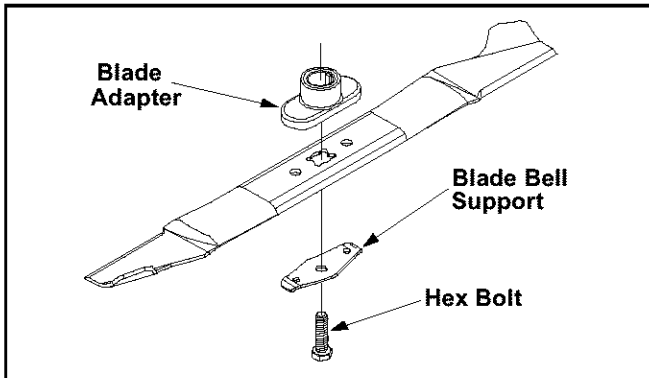

Figure 13



**WARNING:** Periodically inspect the blade adapter for cracks, especially if you strike a foreign object. Replace when necessary.

When sharpening the blade, follow the original angle of grind as a guide. It is extremely important that each cutting edge receives an equal amount of grinding to prevent an unbalanced blade. An unbalanced blade will cause excessive vibration when rotating at high speeds. It may cause damage to the mower, and could break causing personal injury.

The blade can be tested by balancing it on a round shaft screwdriver. Remove metal from the heavy side until it balances evenly. It is recommended that the blade always be removed from the adapter when testing for balance. Before reinstalling the blade and the blade adapter to the unit, lubricate the engine

crankshaft and the inner surface of the blade adapter with light oil.

- Be sure to install the blade with the side of the blade marked "Bottom" (or with part number) facing the ground when the mower is in the operating position.
- Slide the blade adapter onto the engine crankshaft.
- Place the blade on the adapter. Be certain the blade is aligned and seated on the blade adapter flanges.
- Place blade bell support on blade. Make sure the notches on the blade bell support are aligned with small holes in the blade.
- Replace hex bolt and tighten hex bolt to torque: 450 in. lbs. min., 600 in. lbs. max.

**NOTE:** To ensure safe operation of your mower, the blade bolt must be checked periodically for correct torque.

### Storing your Lawn Mower

The following steps should be taken to prepare your lawn mower for storage.

- Clean and lubricate mower thoroughly as described in the lubrication instructions.

**IMPORTANT:** We do not recommend the use of a pressure washer or garden hose to clean your unit.

- Refer to engine manual for correct engine storage instructions.
- Coat mower's cutting blade with chassis grease to prevent rusting.
- Store mower in a dry, clean area. Do not store next to corrosive materials, such as fertilizer.

**NOTE:** When storing any type of power equipment in a poorly ventilated or metal storage shed, care should be taken to rust-proof the equipment. Using a light oil or silicone, coat the equipment, especially cables and all moving parts.

## SECTION 8: TROUBLESHOOTING

Problem	Cause	Remedy
Engine fails to start	<ol style="list-style-type: none"> <li>1. Blade control handle disengaged.</li> <li>2. Spark plug wire disconnected.</li> <li>3. Fuel tank empty or stale fuel.</li> <li>4. Blocked fuel line.</li> <li>5. Faulty spark plug.</li> <li>6. Engine flooded</li> </ol>	<ol style="list-style-type: none"> <li>1. Engage blade control handle.</li> <li>2. Connect wire to spark plug.</li> <li>3. Fill tank with clean, fresh gasoline.</li> <li>4. Clean fuel line.</li> <li>5. Clean, adjust gap, or replace.</li> <li>6. Wait a few minutes to restart, but do not prime.</li> </ol>
Engine runs erratic	<ol style="list-style-type: none"> <li>1. Spark plug wire loose.</li> <li>2. Blocked fuel line or stale fuel.</li> <li>3. Vent in gas plugged.</li> <li>4. Water or dirt in fuel system.</li> <li>5. Dirty air cleaner.</li> <li>6. Carburetor out of adjustment.</li> </ol>	<ol style="list-style-type: none"> <li>1. Connect and tighten spark plug wire.</li> <li>2. Clean fuel line; fill tank with clean, fresh gasoline</li> <li>3. Clear vent.</li> <li>4. Drain fuel tank. Refill with fresh fuel.</li> <li>5. Clean air cleaner.</li> <li>6. Adjust carburetor.</li> </ol>
Engine overheats	<ol style="list-style-type: none"> <li>1. Engine oil level low.</li> <li>2. Air flow restricted.</li> <li>3. Carburetor not adjusted properly.</li> </ol>	<ol style="list-style-type: none"> <li>1. Fill crankcase with proper oil.</li> <li>2. Remove blower housing and clean.</li> <li>3. Adjust carburetor.</li> </ol>
Occasional skip (hesitates) at high speed	<ol style="list-style-type: none"> <li>1. Spark plug gap too close.</li> </ol>	<ol style="list-style-type: none"> <li>1. Adjust gap to .030".</li> </ol>
Idles poorly	<ol style="list-style-type: none"> <li>1. Spark plug fouled, faulty or gap too wide.</li> <li>2. Carburetor improperly adjusted.</li> <li>3. Dirty air cleaner.</li> </ol>	<ol style="list-style-type: none"> <li>1. Reset gap to .030" or replace spark plug.</li> <li>2. Adjust carburetor.</li> <li>3. Clean air cleaner.</li> </ol>
Excessive vibration	<ol style="list-style-type: none"> <li>1. Cutting blade loose or unbalanced.</li> <li>2. Bent cutting blade.</li> </ol>	<ol style="list-style-type: none"> <li>1. Tighten blade and adapter. Balance blade.</li> <li>2. Replace blade.</li> </ol>
Mower will not mulch grass	<ol style="list-style-type: none"> <li>1. Wet grass.</li> <li>2. Excessively high grass.</li> <li>3. Dull blade.</li> </ol>	<ol style="list-style-type: none"> <li>1. Do not mow when grass is wet; wait until later to cut.</li> <li>2. Mow once at a high cutting height, then mow again at desired height or make a narrower cutting path.</li> <li>3. Sharpen or replace blade.</li> </ol>
Uneven cut	<ol style="list-style-type: none"> <li>1. Wheels not positioned correctly.</li> <li>2. Dull blade.</li> </ol>	<ol style="list-style-type: none"> <li>1. Place all four wheels in same height position.</li> <li>2. Sharpen or replace blade.</li> </ol>

**NOTE:** For repairs beyond the minor adjustments listed above, contact your nearest authorized service dealer.

# Notes

# Model Series 580

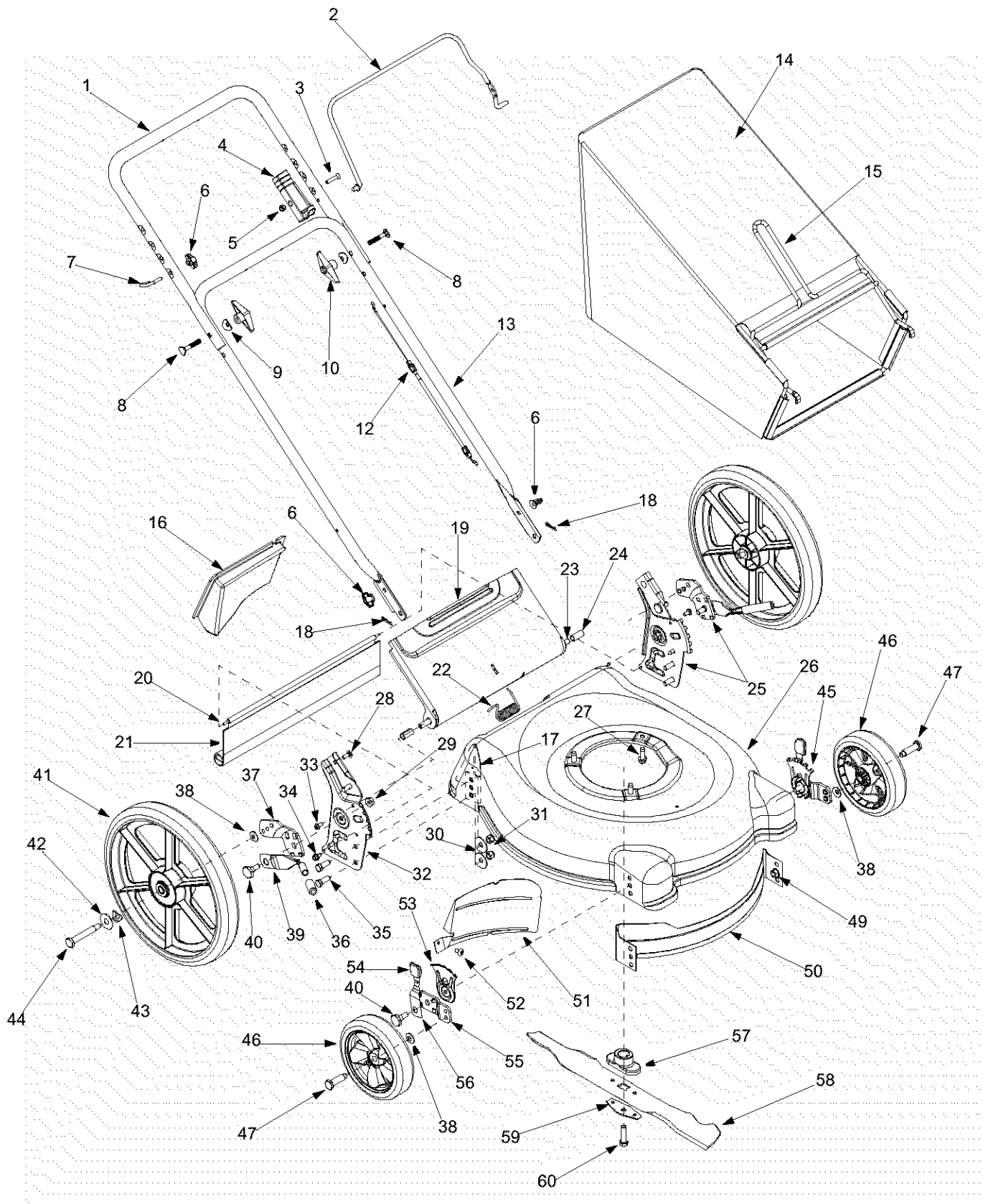



## Model Series 580

Ref. No.	Part No.	Part Description	Ref. No.	Part No.	Part Description
1.	749-0438D	Upper Handle	32.	682-3056A	Handle Bracket Assembly - RH
2.	747-0824	Control Handle		682-3057A	Handle Bracket Assembly - LH
3.	710-1270	C-Sunk Screw 1/4-20 x 1.3"	33.	710-0286	Machine Screw 1/4-20 x .500
4.	746-0883	Throttle Housing	34.	710-0896	Hex Washer Screw 1/4-14 x .625
5.	712-0324	Hex Lock Nut 1/4-20	35.	710-0514	Hex Cap Screw 3/8-16 x 1.0
6.	720-0279	Handle Knob	36.	720-0312	Foam Grip
7.	710-1205	Rope Guide	37.	17488A	Pivot Bar - RH
8.	710-1174	Carriage Bolt 5/16-18 x 2"		17489A	Pivot Bar - LH
9.	736-0451	Shoulder Washer .320 ID x .930 OD	38.	736-0105	Spring Washer .375 ID x .870 OD
10.	720-0284	Wing Nut	39.	732-0866	Spring Lever
12.	746-0551	Blade Control Cable 43"	40.	738-0507B	Shoulder Screw
	746-0554	Blade Control Cable 40.5 "	41.	734-1864	Rear Wheel Assembly 14 x 1.8
13.	749-0907B	Lower Handle	42.	736-0456	Flat Washer .510 ID x 1.37 OD
14.	664-0084	Grass Bag	43.	736-0182	Wave Washer .500 ID x 1.0 OD
15.	747-0995A	Grass Catcher Frame	44.	738-0481A	Shoulder Screw
16.	782-5007A	Rear Mulch Plug	45.	14578	Front Height Adjuster - RH
17.	782-5004	Rear Baffle - RH		14579	Front Height Adjuster - LH
18.	714-0104	Hairpin Clip	46.	734-1988	Front Wheel Assembly 7 x 1.8
19.	782-7599A	Grass Bag Door	47.	738-0102	Shoulder Bolt
20.	732-0700	Wire Rod	49.	712-0431	Flange Lock Nut 3/8-16
21.	731-1236	Trailshield	50.	782-5002	Front Baffle
22.	732-0809	Door Spring	51.	782-5003	Rear Baffle - LH
23.	747-0996	Chute Door Pivot Rod	52.	710-1017	Tap Screw 1/4-14 x .625.
24.	750-0434	Spacer .375 O.D. x .50 I.D. x 1.02"	53.	15261A	Height Adjustment Plate
25.	682-3058	Handle Bracket Assembly - LH	54.	720-0426	Height Adjustment Knob
	682-3059	Handle Bracket Assembly - RH	55.	15262B	Pivot Bar
26.	782-0310A	Deck 21"	56.	732-0404	Spring Lever
27.	710-0654A	Hex Washer Screw 3/8-16 x 1.0	57.	748-0376C	Blade Adapter
28.	710-0703	Hex Carriage Screw 1/4-20	58.	742-0741	21" Mulching
29.	712-3005	Flange Lock Nut 3/8-16		742-0641	21" Standard
30.	736-0356	Bell Washer .390 ID x .380 OD	59.	736-0524A	Blade Bell Support
31.	712-0130	Hex Lock Nut 3/8-16	60.	710-1044	Hex Cap Screw 3/8-24 x 1.5





# MANUFACTURER'S LIMITED WARRANTY FOR:



The limited warranty set forth below is given by MTD LLC with respect to new merchandise purchased and used in the United States, its possessions and territories.

MTD LLC warrants this product against defects for a period of two (2) years commencing on the date of original purchase and will, at its option, repair or replace, free of charge, any part found to be defective in materials or workmanship. This limited warranty shall only apply if this product has been operated and maintained in accordance with the Operator's Manual furnished with the product, and has not been subject to misuse, abuse, commercial use, neglect, accident, improper maintenance, alteration, vandalism, theft, fire, water, or damage because of other peril or natural disaster. Damage resulting from the installation or use of any accessory or attachment not approved by MTD LLC for use with the product(s) covered by this manual will void your warranty as to any resulting damage.

Normal wear parts or components thereof are subject to separate terms as follows: All normal wear parts or component failures will be covered on the product for a period of 90 days regardless of cause. After 90 days, but within the two year period, normal wear part failures will be covered ONLY IF caused by defects in materials or workmanship of OTHER component parts. Normal wear parts and components include, but are not limited to: batteries, belts, blades, blade adapters, grass bags, rider deck wheels, seats, snow thrower skid shoes, shave plates, auger spiral rubber, tires.

**HOW TO OBTAIN SERVICE:** Warranty service is available, WITH PROOF OF PURCHASE, through your local authorized service dealer. To locate the dealer in your area, check your Yellow Pages, or contact MTD LLC at P.O. Box 361131, Cleveland, Ohio 44136-0019, 1-800-800-7310, 1-330-220-4683 or log on to our Web site at [www.mtdproducts.com](http://www.mtdproducts.com).

This limited warranty does not provide coverage in the following cases:

- a. The engine or component parts thereof. These items carry a separate manufacturer's warranty. Refer to the applicable manufacturer's warranty for terms and conditions.
- b. Log splitter pumps, valves, and cylinders have a separate one year warranty.
- c. Routine maintenance items such as lubricants, filters, blade sharpening, tune-ups, brake adjustments, clutch adjustments, deck adjustments, and normal deterioration of the exterior finish due to use or exposure.
- d. MTD LLC does not extend any warranty for products sold or exported outside of the United States, its possessions and territories, except those sold through MTD LLC's authorized channels of export distribution.
- e. Parts that are not genuine MTD parts are not covered by this warranty.
- f. Service completed by someone other than an authorized service dealer is not covered by this warranty.
- g. Transportation charges and service calls are not covered.

**No implied warranty, including any implied warranty of merchantability of fitness for a particular purpose, applies after the applicable period of express written warranty above as to the parts as identified. No other express warranty, whether written or oral, except as mentioned above, given by any person or entity, including a dealer or retailer, with respect to any product, shall bind MTD LLC. During the period of the warranty, the exclusive remedy is repair or replacement of the product as set forth above.**

**The provisions as set forth in this warranty provide the sole and exclusive remedy arising from the sale. MTD LLC shall not be liable for incidental or consequential loss or damage including, without limitation, expenses incurred for substitute or replacement lawn care services or for rental expenses to temporarily replace a warranted product.**

Some states do not allow the exclusion or limitation of incidental or consequential damages, or limitations on how long an implied warranty lasts, so the above exclusions or limitations may not apply to you.

In no event shall recovery of any kind be greater than the amount of the purchase price of the product sold. **Alteration of safety features of the product shall void this warranty.** You assume the risk and liability for loss, damage, or injury to you and your property and/or to others and their property arising out of the misuse or inability to use the product.

This limited warranty shall not extend to anyone other than the original purchaser or to the person for whom it was purchased as a gift.

**HOW STATE LAW RELATES TO THIS WARRANTY: This limited warranty gives you specific legal rights, and you may also have other rights which vary from state to state.**