



OPERATOR'S MANUAL

Edger Model 592



IMPORTANT: READ SAFETY RULES AND INSTRUCTIONS CAREFULLY

Warning: This unit is equipped with an internal combustion engine and should not be used on or near any unimproved forest-covered, brush-covered or grass-covered land unless the engine's exhaust system is equipped with a spark arrester meeting applicable local or state laws (if any). If a spark arrester is used, it should be maintained in effective working order by the operator. In the State of California the above is required by law (Section 4442 of the California Public Resources Code). Other states may have similar laws. Federal laws apply on federal lands. A spark arrester for the muffler is available through your nearest engine authorized service dealer or contact the service department, P.O. Box 361131 Cleveland, Ohio 44136-0019.

TROY-BILT LLC P.O. BOX 361131 CLEVELAND, OHIO 44136-0019

PRINTED IN U.S.A.

FORM NO. 769-00044
(12/01)

TABLE OF CONTENTS

Content	Page
Important Safe Operation Practices	3
Assembling The Edger	5
Know The Edger.....	6
Operating The Edger	7
Making Adjustments	8
Maintaining and Servicing The Edger.....	10
Troubleshooting	12
Parts List	13
Warranty Information.....	Back Cover

FINDING MODEL NUMBER

This Operator's Manual is an important part of your new edger. It will help you assemble, prepare and maintain the unit for best performance. Please read and understand what it says.



Before you start assembling your new equipment, please locate the model plate on the equipment and copy the information from it in the space provided below. The information on the model plate is very important if you need help from your your dealer or the *MTD* Customer Support department.

•You can locate the model number by looking on the surface of the base plate in the rear of the edger. A sample model plate is explained below. For future reference, please copy the model number and the serial number of the equipment in the space below.

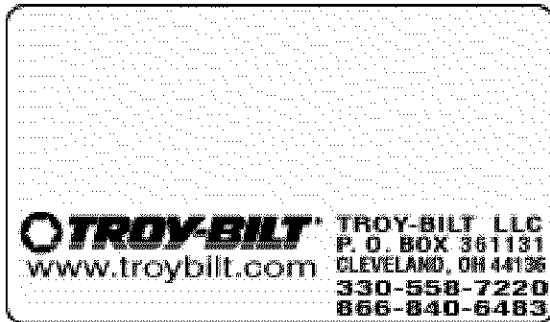

Copy the model number here: _____

Copy the serial number here: _____

ENGINE INFORMATION

The engine manufacturer is responsible for all engine-related issues with regards to performance, power-rating, specifications, warranty and service. Please refer to the engine manufacturer's Owner's/Operator's Manual packed separately with your unit for more information.

CALLING CUSTOMER SUPPORT

If you have difficulty assembling this product or have any questions regarding the controls, operation or maintenance of this unit, please call the Customer Support Department.



Call 1- (330) 558-7220 or 1- (866)-840-6483 to reach a Customer Support representative. Please have your unit's model number and serial number ready when you call. See previous section to locate this information. You will be asked to enter the serial number in order to process your call.

For more details about your unit, visit our website at www.troybilt.com

SECTION 1: IMPORTANT SAFE OPERATION PRACTICES



WARNING: THIS SYMBOL POINTS OUT IMPORTANT SAFETY INSTRUCTIONS WHICH, IF NOT FOLLOWED, COULD ENDANGER THE PERSONAL SAFETY AND/OR PROPERTY OF YOURSELF AND OTHERS. READ AND FOLLOW ALL INSTRUCTIONS IN THIS MANUAL BEFORE ATTEMPTING TO OPERATE THIS MACHINE. FAILURE TO COMPLY WITH THESE INSTRUCTIONS MAY RESULT IN PERSONAL INJURY. WHEN YOU SEE THIS SYMBOL — HEED ITS WARNING.



WARNING: The Engine Exhaust from this product contains chemicals known to the State of California to cause cancer, birth defects or other reproductive harm.



DANGER: This machine was built to be operated according to the rules for safe operation in this manual. As with any type of power equipment, carelessness or error on the part of the operator can result in serious injury. If you violate any of these rules, you may cause serious injury to yourself or others.

TRAINING

1. Read, understand, and follow all instructions on the machine and in the manual(s) before attempting to assemble and operate. Keep this manual in a safe place for future and regular reference and for ordering replacement parts.
 2. Be familiar with all controls and their proper operation. Know how to stop the machine and disengage them quickly.
 3. Never allow children under 14 years old to operate this machine. Children 14 years old and over should read and understand the operation instructions and safety rules in this manual and should be trained and supervised by a parent.
 4. Never allow adults to operate this machine without proper instruction.
 5. To help avoid blade contact or a thrown object injury, keep bystanders, helpers, children and pets at least 75 feet from the machine while it is in operation. Stop machine if anyone enters the area.
4. Never attempt to make any adjustments while the engine is running, except where specifically recommended in the operator's manual.
 5. To avoid personal injury or property damage use extreme care in handling gasoline. Gasoline is extremely flammable and the vapors are explosive. Serious personal injury can occur when gasoline is spilled on yourself or your clothes which can ignite. Wash your skin and change clothes immediately.
 - a. Use only an approved gasoline container.
 - b. Extinguish all cigarettes, cigars, pipes and other sources of ignition.
 - c. Never fuel machine indoors.
 - d. Never remove gas cap or add fuel while the engine is hot or running.
 - e. Allow engine to cool at least two minutes before refueling.
 - f. Never over fill fuel tank. Fill tank to no more than ½ inch below bottom of filler neck to provide space for fuel expansion.
 - g. Replace gasoline cap and tighten securely.
 - h. If gasoline is spilled, wipe it off the engine and equipment. Move unit to another area. Wait five minutes before starting the engine.
 - i. Never store the machine or fuel container inside where there is an open flame, spark or pilot light as on a water heater, space heater, furnace ,clothes dryer or other gas appliances.
 - j. Allow machine to cool at least 5 minutes before storing.

PREPARATION

1. Thoroughly inspect the area where the equipment is to be used. Remove all stones, sticks, wire, bones, toys and other foreign objects which could be tripped over or picked up and thrown by the blade. Thrown objects can cause serious personal injury.
2. Always wear safety glasses or safety goggles during operation and while performing an adjustment or repair to protect your eyes. Thrown objects which ricochet can cause serious injury to the eyes.
3. Wear sturdy, rough-soled work shoes and close-fitting slacks and shirts. Shirts and pants that cover the arms and legs and steel-toed shoes are recommended. Never operate this machine in bare feet, sandals, slippery or light weight (e.g. canvas) shoes.

OPERATION

1. Do not put hands or feet near rotating parts. Contact with the rotating blade can amputate hands and feet.
2. The blade control handle is a safety device. Never bypass its operation. Doing so, makes the machine unsafe and may cause personal injury.
3. Never operate without blade guard, debris shield and blade control handle in place and working.

4. Never operate with damaged safety devices. Failure to do so, can result in personal injury.
5. Never run an engine indoors or in a poorly ventilated area. Engine exhaust contains carbon monoxide, an odorless and deadly gas.
6. Do not operate machine while under the influence of alcohol or drugs.
7. Muffler and engine become hot and can cause a burn. Do not touch.
8. Never operate this machine without good visibility or light. Always be sure of your footing and keep a firm hold on the handles. Walk, never run.
9. Do not operate this machine if it has been dropped or damaged. Return machine to your nearest authorized servicing dealer for examination and repair.
10. Do not operate this machine with a damaged or excessively worn cutting blade.
11. Never attempt to clear material from the blade guard while the engine is running. Shut the engine off, disconnect the spark plug wire and ground against the engine to prevent unintended starting.
12. Do not overload machine capacity by attempting to edge at too fast of a rate.
13. Stay alert for uneven sidewalks, terrain etc. Always push slowly over rough surfaces. Do not use this machine on gravel surfaces.
14. Do not operate machine in rain or wet soil conditions.
15. Always operate machine from behind the handles and position yourself where the direct line of sight to cutting blade is blocked by guards.
16. Always stop engine when edging or trimming is delayed or when transporting machine from one location to another.
17. Never leave a running machine unattended. Stop the engine, disconnect spark plug wire and ground against the engine to prevent unintended starting.

18. Only use parts and accessories made for this machine by the manufacturer. Failure to do so, can result in personal injury.
19. If situations occur which are not covered in this manual, use care and good judgment. Contact an authorized *MTD* service dealer or telephone 1-800-800-7310.

MAINTENANCE AND STORAGE

1. Never tamper with safety devices. Check their proper operation regularly.
2. Before cleaning, repairing, or inspecting, disconnect the spark plug wire and ground against the engine to prevent unintended starting.
3. Check bolts, and screws for proper tightness at frequent intervals to keep the machine in safe working condition. Also, visually inspect machine for any damage.
4. Do not change the engine governor setting or over-speed the engine. The governor controls the maximum safe operating speed of the engine.
5. The blade, blade guard and debris shield are subject to wear and damage. For your safety protection, frequently check all components and replace with original equipment manufacturer's (O.E.M.) parts only. "Use of parts which do not meet the original equipment specifications may lead to improper performance and compromise safety!"
6. Maintain or replace safety and instruction labels, as necessary.
7. Observe proper disposal laws and regulations for gas, oil, etc. to protect the environment.
8. Never store the machine or fuel container inside where there is an open flame, spark or pilot light such as a water heater, furnace, clothes dryer etc.
9. Always refer to the operator's manual for proper instructions on off-season storage.



WARNING: YOUR RESPONSIBILITY

Restrict the use of this power machine to persons who read, understand and follow the warnings and instructions in this manual and on the machine.

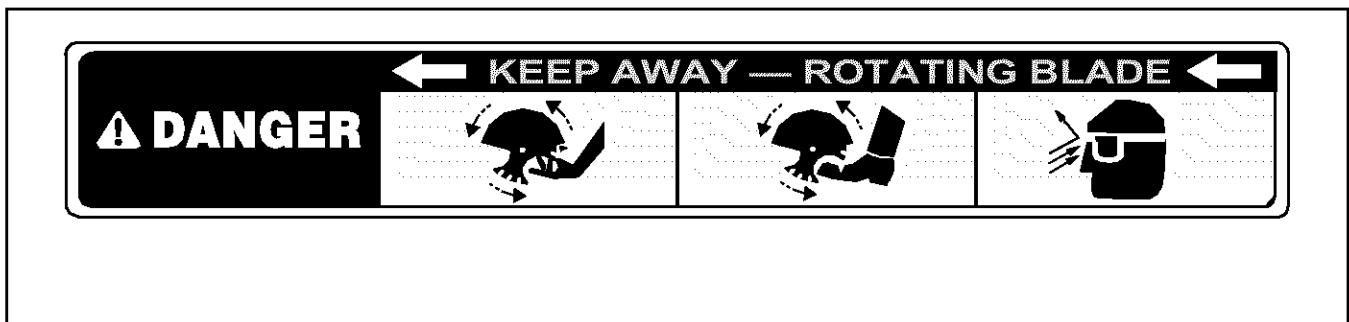

Figure 1

SECTION 2: ASSEMBLING YOUR EDGER

IMPORTANT: This unit is shipped WITHOUT GASOLINE or OIL. After setting up the unit, service engine with gasoline and oil as instructed in the *Briggs & Stratton* Owner/Operator Manual packed with your edger.

NOTE: Reference to right or left hand side of the edger is observed from the operating position.

Contents of Carton

One Edger Assembly

One Plastic Bag Containing:

Edger Operator's Manual

Registration Card

Engine Owner's Guide

One Clutch Rod (747-1164) with

One Ferrule (711-0392)

Two Flat Washers (736-0264) and

Two Hairpin Clips (714-0104) in place

Grounding the Engine's Spark Plug

- Disconnect the spark plug wire from the spark plug and ground it on the top of the engine by placing its rubber boot snugly over a bolt head. See Figure 2.

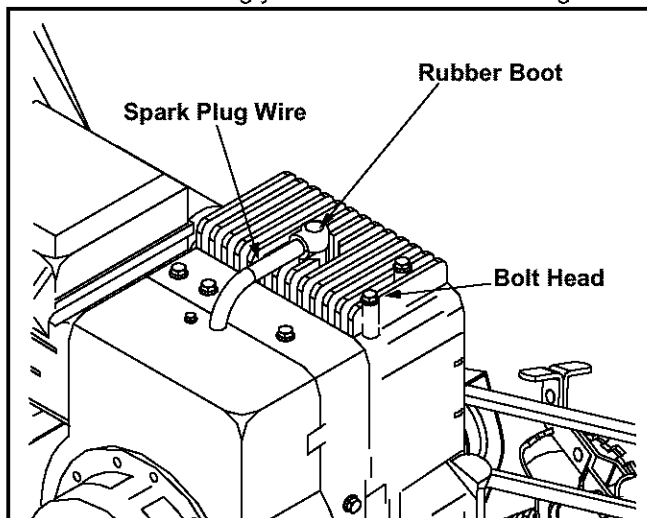

Figure 2

Positioning the Edger Handles

- Remove and discard any packaging cardboard that may be present between the upper handle and the lower handle.
- Pivot the upper handle upward until it snaps into place.
- Tighten the wing knobs which are located on both the left and right sides of the handle. See Figure 3.

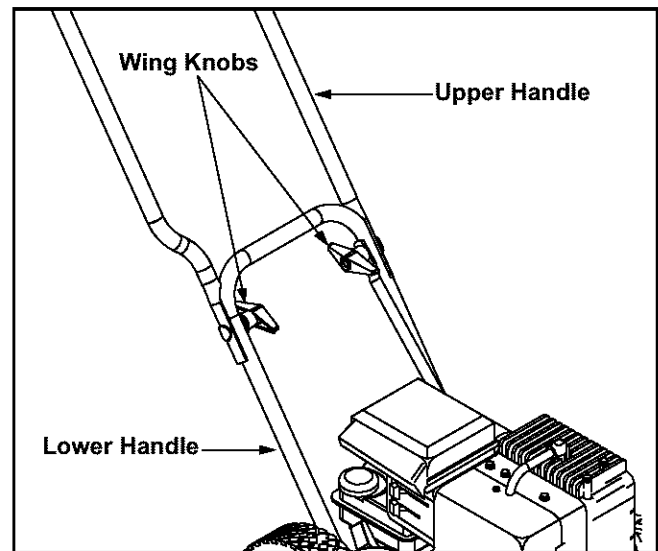

Figure 3

- Remove the flat washer and hairpin clip from the ferrule found on the upper portion of the clutch rod. Save this hardware as it will be reinserted.
- Insert the ferrule located on the upper portion of the clutch rod into the hole on the blade clutch/depth control lever. Secure with the flat washer and hairpin clip removed earlier. See Figure 4.

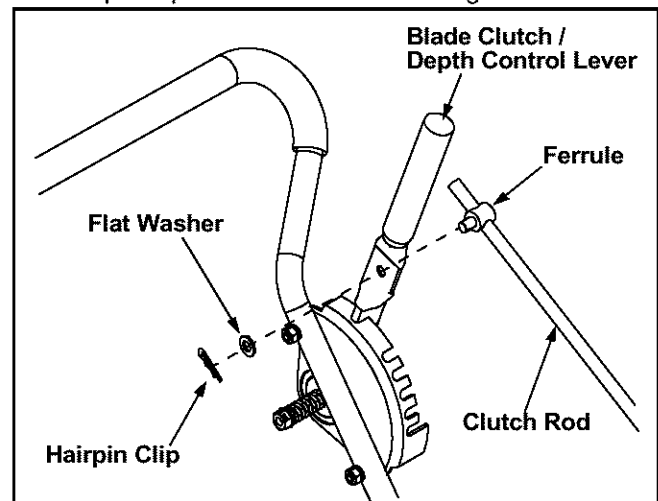

Figure 4

- Remove the flat washer and hairpin clip from the lower portion of the clutch rod. Save this hardware as it will be reinserted.
- Insert the lower end of the clutch rod into the hole in the pivot arm found on the left side of the edger.
- Secure with the flat washer and hairpin clip removed earlier. See Figure 5.

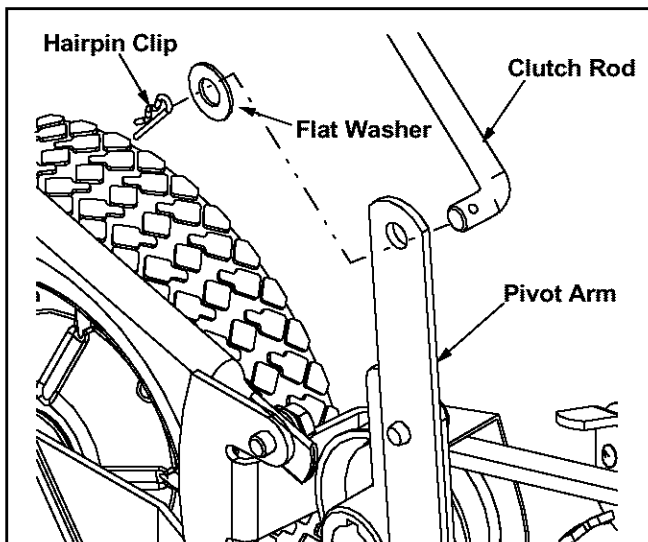

Figure 5

IMPORTANT: Perform the clutch rod adjustment before operating the edger.

Clutch Rod Adjustment

Before operating the edger, check the adjustment of the clutch rod as follows:

- Disconnect the spark plug wire and ground it as instructed earlier in this section. Refer to Figure 2.
- With the blade clutch/depth control lever in the disengaged position (the top notch in the depth adjustment bracket), carefully pull the recoil starter rope. The blade on the edger should not turn. If the blade turns, remove the ferrule from the blade clutch/depth control lever by first removing the hairpin clip and flat washer.
- Rotate the ferrule clockwise one or two turns on the clutch rod, then re-insert the ferrule into the lever and recheck the adjustment.
- After adjusting, check to be certain the blade clutch/depth control lever can be moved to the furthest notch forward without bowing the clutch rod. If it can't, recheck the adjustment.

IMPORTANT: Be certain that the clutch rod is secured at both ends with a flat washer and hairpin clip before operating the edger.



WARNING: When operating the edger, stop engine immediately and readjust the clutch rod if the blade turns with the blade clutch/depth control lever in the disengaged position.

SECTION 3: KNOW THE EDGER

Throttle Control

The throttle control lever is located on the engine. It can be adjusted to regulate the engine speed only.

NOTE: Refer to the Briggs & Stratton Owner/Operator Manual packed with your edger for a detailed description of all engine-related controls and components.

Choke Control

The choke control lever is located on the engine. It is used to aid in starting a cold engine.

NOTE: Refer to the Briggs & Stratton Owner/Operator Manual packed with your edger for a detailed description of all engine-related controls and components.

Blade Clutch / Depth Control Lever

The blade clutch/depth control lever is located on the right side of the upper handle. It is used to engage and disengage the edger blade. It is also used to control the depth of the cut. The further forward the control lever is moved, the deeper into the soil the edger blade will cut.

Pull Rope / Recoil Starter

The pull rope/recoil starter is used to start the engine.

NOTE: Refer to the Briggs & Stratton Owner/Operator Manual packed with your edger for a detailed description of all engine-related controls and components.

Blade Angle Adjustment Lever

The blade angle adjustment lever is located on the front, left portion of the edger, behind the edger blade. It is used to vary the angle of the edger blade between one of eight positions from trenching to trimming.

Curb Height Adjustment Lever

The curb height adjustment lever is found on the rear, right portion of the edger. It aids in stabilizing the edger operating along a curb.

IMPORTANT: Become familiar with all the controls before operating the edger.

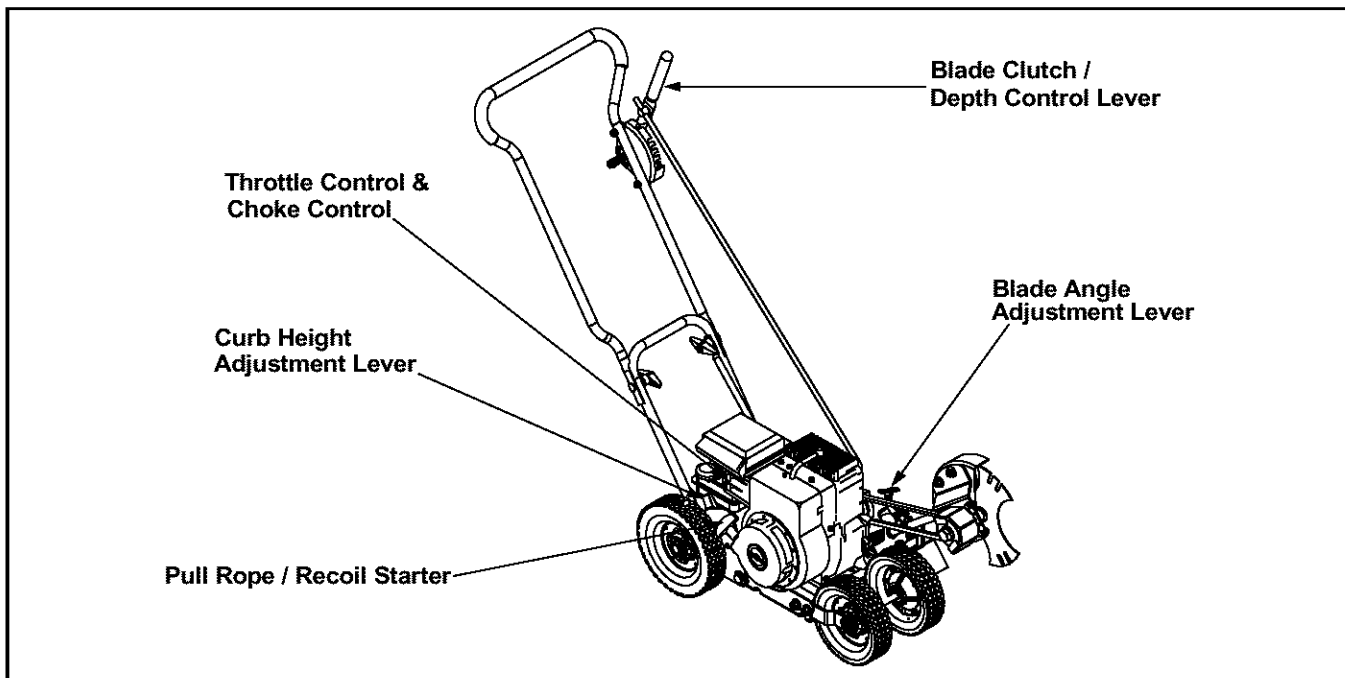

Figure 6

SECTION 4: OPERATING THE EDGER



The operation of any edger can result in foreign objects being thrown into the eyes, which can result in severe eye damage. Always wear safety glasses or eye shields. We recommend wide vision safety mask for over spectacles or standard safety glasses



WARNING: Do not lower blade if blade is over concrete, asphalt, rocks or the like. The blade can strike the supporting surface, resulting in personal injury or property damage.

Adding Gasoline And Oil

Service the engine with gasoline and oil as instructed in the *Briggs & Stratton Owner/Operator Manual* packed with your edger. Read instructions carefully.



WARNING: Never fill fuel tank indoors, with engine running or until the engine has been allowed to cool for at least two minutes after running.

Starting The Engine

NOTE: Refer to the *Briggs & Stratton Owner/Operator Manual* packed with your edger for a detailed description of all engine-related controls and components.

To start the edger's engine, proceed as follows:

- Attach the spark plug wire to the spark plug. Make certain the metal cap on the end of the spark plug wire is fastened securely over the metal tip on the spark plug.
- Move the blade clutch/depth control lever back to the disengaged position, and place it in the adjacent (top) notch.
- Move the choke control lever on the engine into the CHOKE or START position.
- Move the throttle control lever on the engine into the FAST (Rabbit) position.
- Grasp the starter handle and slowly pull the rope outward until engine reaches the start of its compression cycle (the rope will pull slightly harder at this point).
- After slowly allowing the rope to recoil, pull the rope with a rapid, continuous, full arm stroke. Keep a firm grip on starter handle throughout the entire stroke.
- Allow the starter handle to slowly recoil into the engine.
- Slowly move the choke control lever on the engine into the RUN position after the engine has started.

Stopping The Engine

To stop the edger's engine, proceed as follows:

- Move the blade clutch/depth control lever back to the disengaged position, and place it in the adjacent (top) notch.

- Move the throttle control lever on the engine into the STOP or OFF position.

IMPORTANT: Make certain that the engine's spark plug wire is properly grounded as instructed in SECTION 2: Assembling The Edger before storing the edger for its next use. Refer to Figure 2.

Engaging the Edger Blade



WARNING: The blade clutch/depth control lever is designed to minimize the risk of blade contact injury. Do not under any circumstances attempt to defeat the function of the blade clutch/depth control, or use the edger if the control is not adjusted properly.



WARNING: Keep hands and feet away from edger blade whenever the engine is running, whether blade is engaged or disengaged.

The blade clutch/depth control lever has two main functions:

1. To engage and disengage the blade.
2. To control the depth of cut.

To disengage the blade, proceed as follows:

- Move the blade clutch/depth control lever to the left and place it in the top notch in the depth adjustment bracket. See Figure 7.

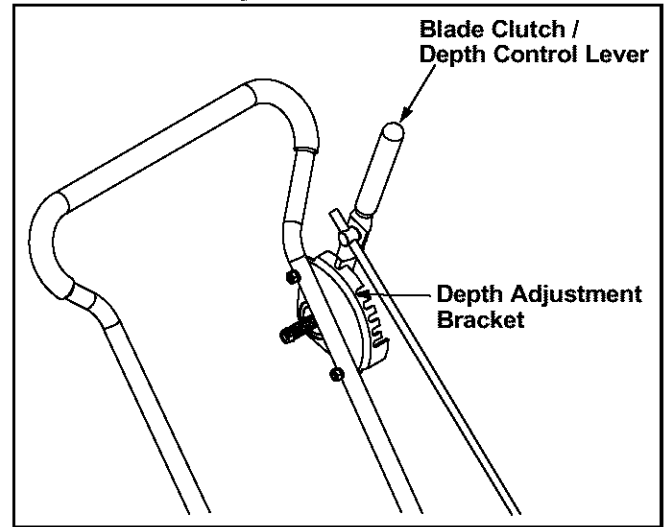

Figure 7

To engage the blade, proceed as follows:

- Move the control lever to the left and place it into any of the five lower notches. The further forward the blade clutch/depth control lever is moved, the deeper or lower the blade will cut into the ground.

SECTION 5: MAKING ADJUSTMENTS

Front Wheel Adjustment



WARNING: Always place the blade clutch/depth control lever in the DISENGAGED position and turn the edger's engine off before performing any adjustments.

Before operating the edger with the blade in the trimming (horizontal) position, it is necessary to alter the position of the front, **left** wheel.

When operating the edger with the curb wheel lowered, it is necessary to alter the position of the front, **right** wheel. To do either, proceed as follows:

- To change position of the front, left wheel, remove the hairpin clip on the left. To change position of the front, right wheel, remove the hairpin clip on the right. See Figure 8.
- Reposition the wheel by sliding it down the front axle toward the opposite wheel. See Figure 8.
- Secure the wheel in its new location by inserting the hairpin clip removed earlier in the hole found immediately adjacent to it. See Figure 8.

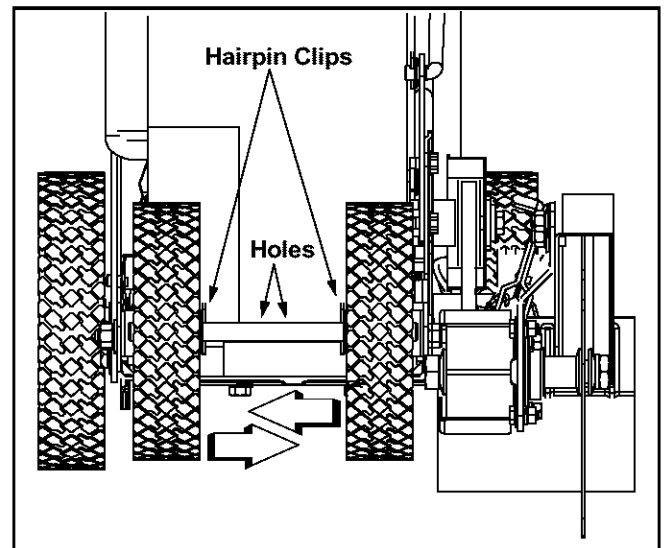

Figure 8

Edger Blade Angle Adjustment



WARNING: Rotating cutting blade may throw objects causing personal injury. Keep area clear of bystanders and do not operate without guards in place.

The cutting blade can be adjusted to eight positions. To adjust the blade angle, proceed as follows:

- Place the blade clutch/depth control lever in the disengaged position (top notch).



WARNING: Always place the blade clutch/depth control lever in the **DISENGAGED** position before adjusting the blade angle.

- Pull forward on the blade angle adjustment lever before rotating the spindle assembly.
- Release the blade angle adjustment lever into one of the notches on the pivot bracket. See Figure 9.

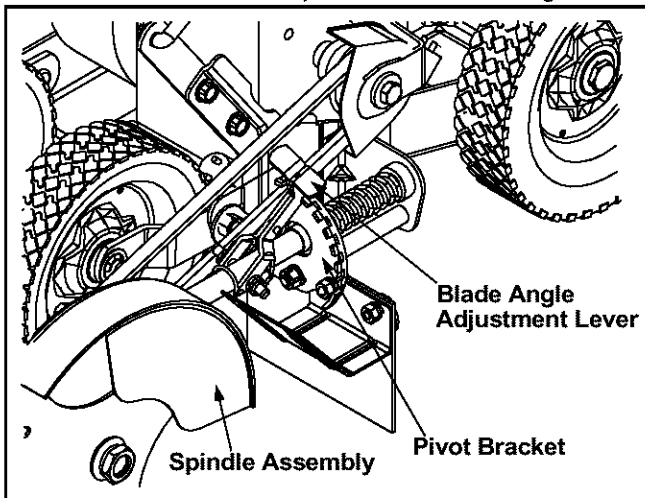

Figure 9

Trenching

Placing the blade angle adjustment lever in the notch furthest to the right will put the spindle assembly at a proper angle for trenching with the edger as illustrated in Figure 10.

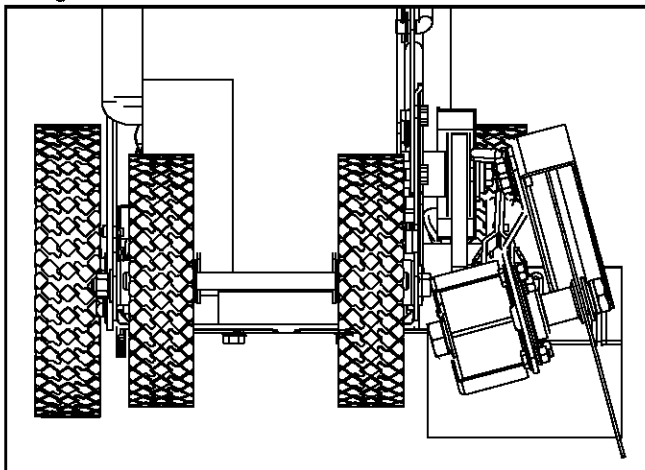

Figure 10

Edging

Placing the blade angle adjustment lever in the second notch from the right will put the spindle assembly at a 90° angle for vertical edging as illustrated in Figure 11.

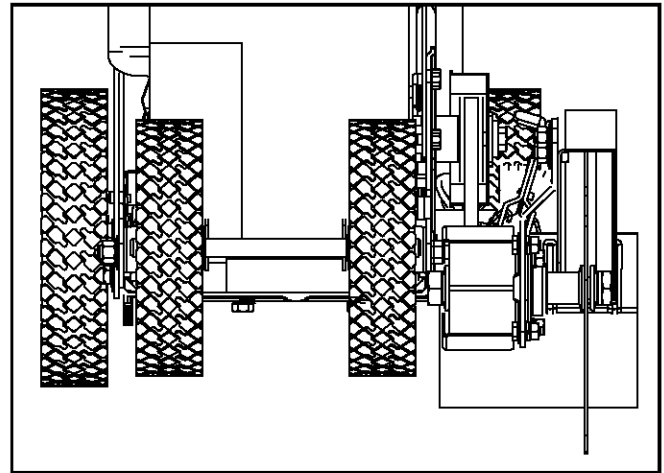

Figure 11

Beveling

Placing the blade angle adjustment lever in the third, fourth, fifth, sixth or seventh notch (from the right) will put the spindle assembly at various angles for beveling with the edger as illustrated in Figure 12.

IMPORTANT: When the spindle assembly is rotated counter-clockwise (putting the blade closer to a horizontal position), it IS necessary to change the position of the front, left wheel to prevent the edger blade from striking the wheel. See **Front Wheel Adjustment** earlier in this section.

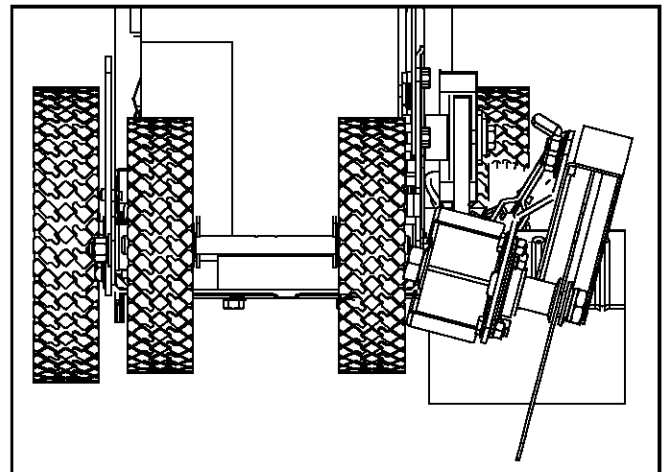

Figure 12



WARNING: Always place the blade clutch/depth control lever in the **DISENGAGED** position before adjusting the blade angle.

Trimming

Placing the blade angle adjustment lever in the notch furthest to the left will put the spindle assembly at a proper angle for trimming with the edger as illustrated in Figure 13.

IMPORTANT: When the spindle assembly is rotated counter-clockwise (putting the blade closer to a horizontal position), it IS necessary to change the position of the front, left wheel to prevent the edger blade from striking the wheel. See **Front Wheel Adjustment** earlier in this section.

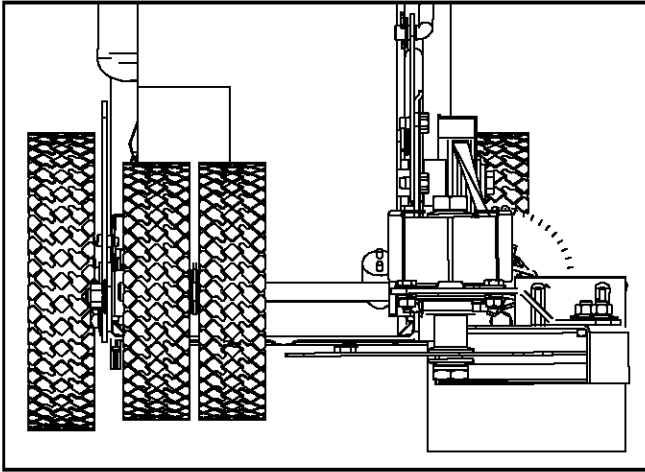

Figure 13

Curb Wheel Adjustment

The right, rear wheel of the edger can be lowered into one of five positions to ease the task of edging along a curb.

To adjust the height of the curb wheel, proceed as follows:

- Perform the **Front Wheel Adjustment** for curb wheel operation as instructed earlier in this section.
- Lower the right, rear wheel by moving the curb height adjustment lever slightly to the left.
- Place the right, rear wheel into an applicable position in relation to the height of the curb to be edged along.
- Release the curb height adjustment lever to lock the wheel in position. See Figure 14.

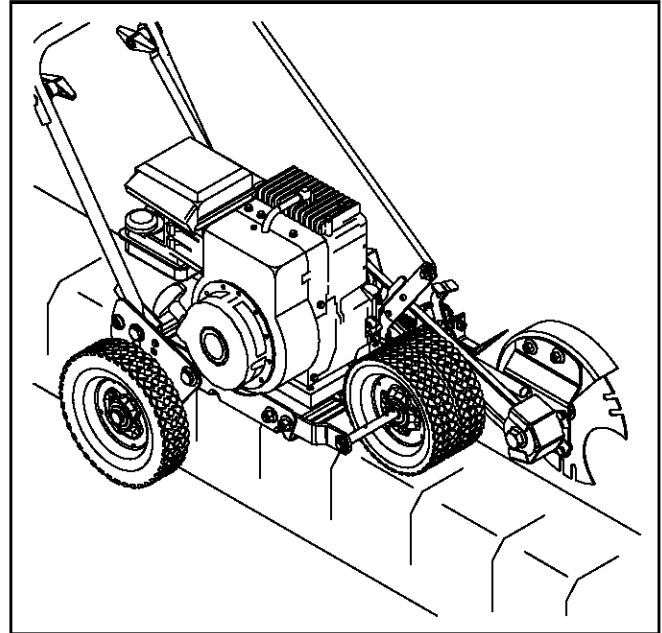

Figure 14

SECTION 6: MAINTAINING & SERVICING THE EDGER



WARNING: Disconnect the spark plug wire and ground against the engine before performing any adjustment, repairs or maintenance. Refer to Figure 2.

Lubrication

Engine

Refer to the **Service, Storage & Specifications** section of the *Briggs & Stratton Owner/Operator Manual* packed with the edger for all engine-related service specifications.

Wheels & Front Axle

Lubricate the wheels and front axle at least once a season with a light oil. Also if the wheels are removed for any reason, lubricate the surface of the axle bolt and the inner surface of the wheel with light oil.

Pivot Points

Lubricate the pivot points on the blade angle adjustment lever, blade clutch/depth control lever and curb height adjustment lever with light oil at least once a season.

Cutting Head Bearings

The two ball bearings in the blade spindle housing are lubricated and sealed at the factory and require no lubrication.

Spindle Shaft

Lubricate the two shoulder spacers and the entire area surrounding the compression spring on the edger's spindle shaft with light oil (NOT WD-40) frequently during the season. Do NOT allow rust to form in this area. See Figure 15.

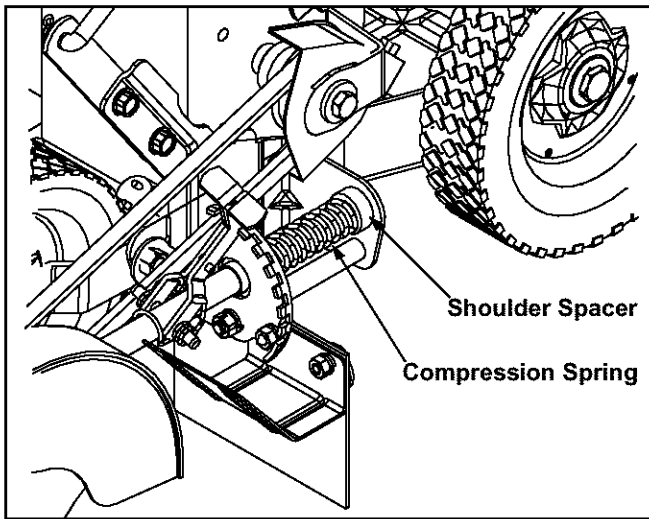

Figure 15

Replacing the Edger Blade

- Use two wrenches (one wrench to prevent the hex bolt head from spinning and the other to remove the hex lock nut) to remove the edger blade. See Figure 16.

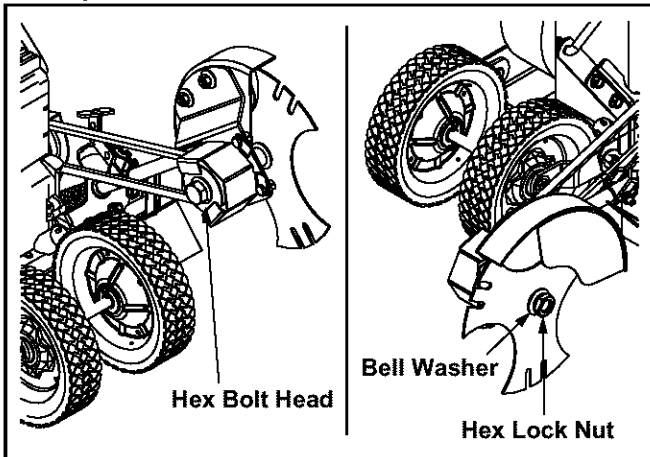

Figure 16

- Remove and discard the edger blade but retain the bell washer and hex lock nut.
- Install the replacement edger blade, the bell washer (cupped side facing **inward**) and the hex lock nut removed earlier.

IMPORTANT: Use a torque wrench to tighten the hex lock nut to between 37 foot-lbs. and 50 foot-lbs.

Replacing the Drive Belt

The edger drive belt is subject to wear and should be replaced if any signs of cracking, shredding or rotting are present. To replace the belt, proceed as follows:

- Place the blade angle adjustment lever in the edging position. Refer to Figure 11.

- Remove the blade spindle belt guard by removing the hex screws, two lock washers and two hex nuts which secure it to the blade spindle plate. See Figure 17.

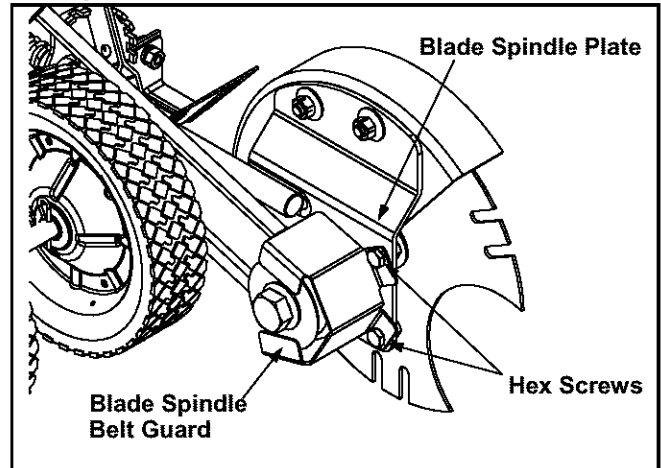

Figure 17

- Remove the belt from around the blade spindle pulley.
- Place the blade clutch/depth control lever in the lowest notch (all the way forward).
- Remove the engine pulley belt guard by removing the two hex screws and two lock washers which secure it to the engine block. See Figure 18.

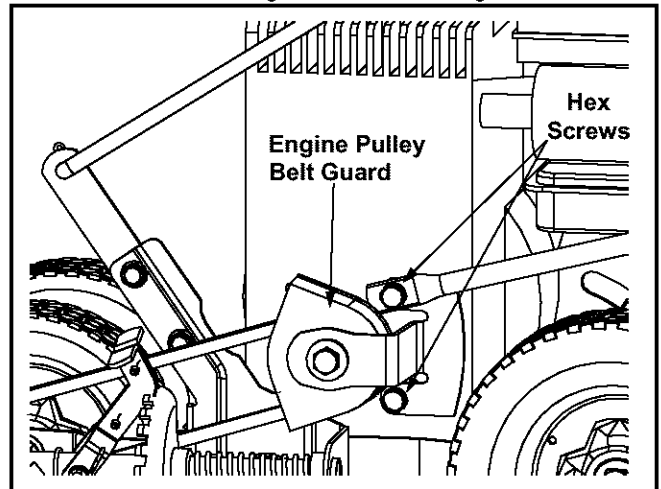

Figure 18

- Remove the belt from around the engine pulley.
- Install the replacement drive belt around both the blade spindle pulley and the engine pulley.
- Reattach the blade spindle belt guard to the blade spindle plate with the hardware removed earlier.
- Reattach the engine pulley belt guard to the engine block with the hardware removed earlier.



WARNING: Never operate the edger without both the blade spindle belt guard and the engine pulley belt guard in place.

Off-Season Storage

Observe the following when preparing the edger for long-term storage:

- Clean and lubricate unit thoroughly as instructed on page 10 of this manual.
- Refer to the **Service, Storage & Specifications** section of the *Briggs & Stratton* Owner/Operator Manual packed with the edger for engine storage instructions.

- Coat the edger blade with chassis grease to prevent rusting and corrosion.
- Store the edger in a dry, clean area. Do not store next to any corrosive materials, such as lawn fertilizer.
- Coat the edger, especially any springs and bearings with a light oil or silicone spray.

IMPORTANT: When storing any type of power equipment in an poorly ventilated or metal storage shed, care should be taken to rustproof the equipment.

SECTION 7: TROUBLESHOOTING

Trouble	Possible Cause(s)	Corrective Action
Engine fails to start	Dirty air cleaner Engine needs to be primed Fuel tank empty Stale fuel in gasoline tank Throttle control lever not in starting position Spark plug wire disconnected. Spark plug fouled Engine flooded	Refer to the <i>Briggs & Stratton</i> Owner/Operator Manual packed with your unit. Push primer bulb two or three times. Fill tank with clean, fresh gasoline. Drain gasoline and refill tank with clean, fresh gasoline. Move throttle lever to FAST position. Connect the spark plug wire to the spark plug. Clean, adjust gap or replace spark plug. Refer to the <i>Briggs & Stratton</i> Owner/Operator Manual packed with your unit.
Engine runs erratic	Spark plug wire loose Stale fuel in gasoline tank Vent in gas cap plugged Water or dirt in fuel system Dirty air cleaner Carburetor out of adjustment	Connect and tighten spark plug wire. Drain gasoline and refill tank with clean, fresh gasoline. Clear vent of any debris. Drain fuel tank. Refill with fresh fuel. Refer to the <i>Briggs & Stratton</i> Owner/Operator Manual packed with your unit. Refer to the <i>Briggs & Stratton</i> Owner/Operator Manual packed with your unit.
Engine overheats	Engine oil level low Air flow restricted Dirty air filter Carburetor not adjusted properly	Fill crankcase with proper oil. Clean the area around the engine's cooling fins. Replace the engine's air filter Refer to the <i>Briggs & Stratton</i> Owner/Operator Manual packed with your unit.
Excessive vibration	Edger blade bent or damaged Blade spindle bent or damaged	Replace edger blade. Contact an authorized <i>MTD</i> service dealer.
Drive belt slips	Belt worn or stretched	Replace drive belt.

Model 592

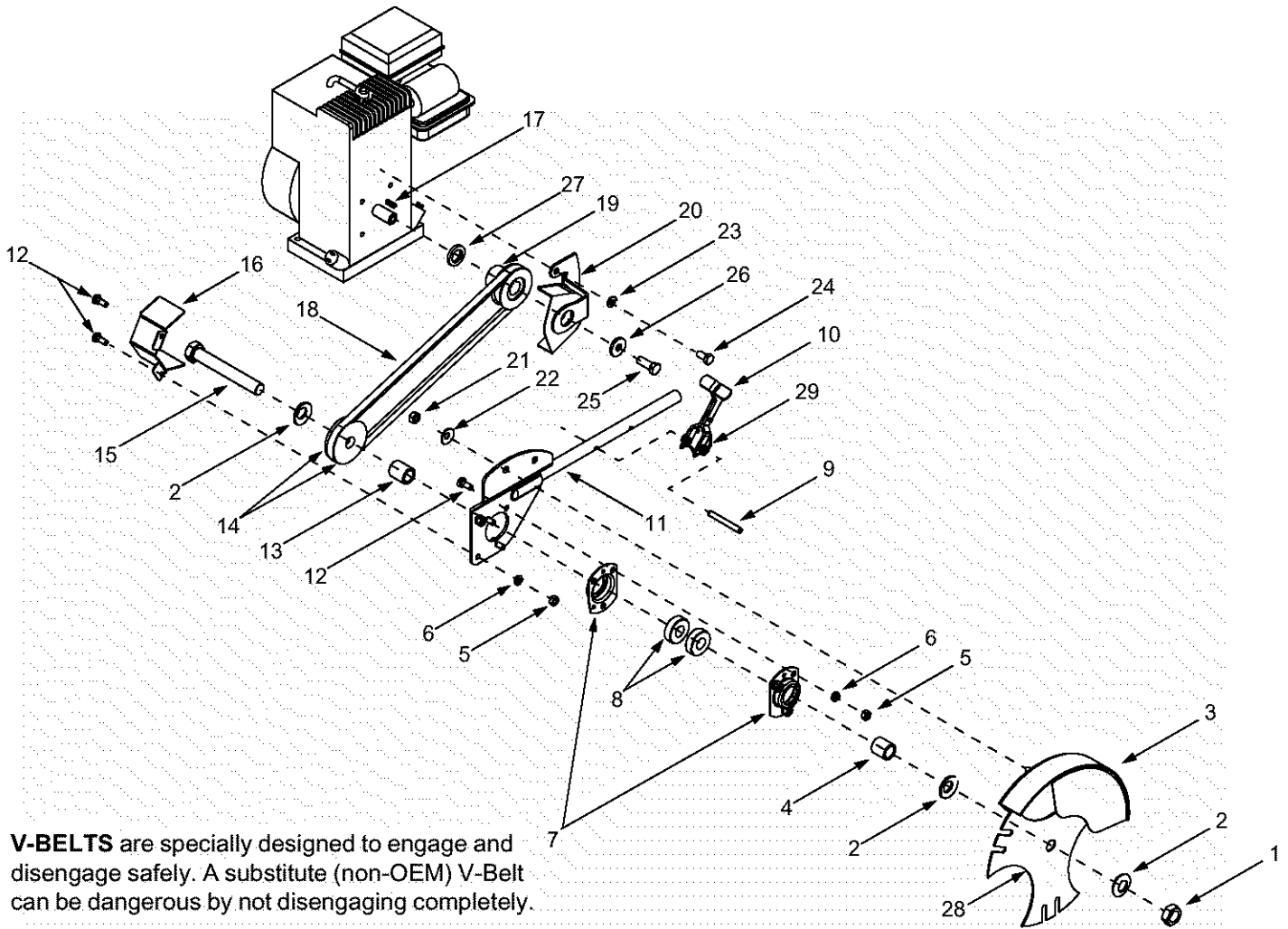

V-BELTS are specially designed to engage and disengage safely. A substitute (non-OEM) V-Belt can be dangerous by not disengaging completely.

Ref. No.	Part No.	Description	Ref. No.	Part No.	Description
1.	712-0413	Hex Jam Nut, 5/8-18	16.	781-0086	Spindle Belt Guard
2.	736-0317	Bell Washer, .64 x 1.25 x .18	17.	714-0122	Square Key, 3/16 x .75
3.	781-0076	Blade Guard	18.	754-0142	V-belt, 3/8
4.	750-0118	Sleeve, .632 x .875 x .90	19.	756-0327B	Engine Pulley, 3/8 x .75 x 2.38
5.	712-0287	Hex Nut, 1/4-20	20.	687-0100	Engine Pulley Belt Guard
6.	736-0329	Lock Washer, 1/4	21.	712-0267	Hex Nut, 5/16-18
7.	05034A	Bearing Housing	22.	736-0242	Belleville Washer, .340 x .872
8.	741-0155	Ball Bearing, .62 x 1.38 x .44	23.	736-0119	Lock Washer, 5/16
9.	715-0121	Spirol Pin, 1/4 x 2.0	24.	710-0237	Hex Cap Screw, 5/16-24 x .625
10.	781-0093	Adjustment Lever Assembly	25.	710-0152	Hex Cap Screw, 3/8-24 x 1.0
11.	781-0078	Spindle Plate/Shaft Assembly	26.	736-0258	Flat Washer, .385 x 1.0 x .135
12.	710-0751	Hex Cap Screw, 1/4-20 x .62	27.	748-0160	Spacer, .753 x 1.25 x .175
13.	750-0229	Spacer, .635 x .88 x 1.03	28.	781-0748	Triplex Edger Blade, 9.0
14.	756-0449	Sheave, .6255 x .6295	29.	732-0188A	Double-torsion Spring
15.	710-0929	Hex Cap Screw, 5/8-18 x 4.5			

Model 592

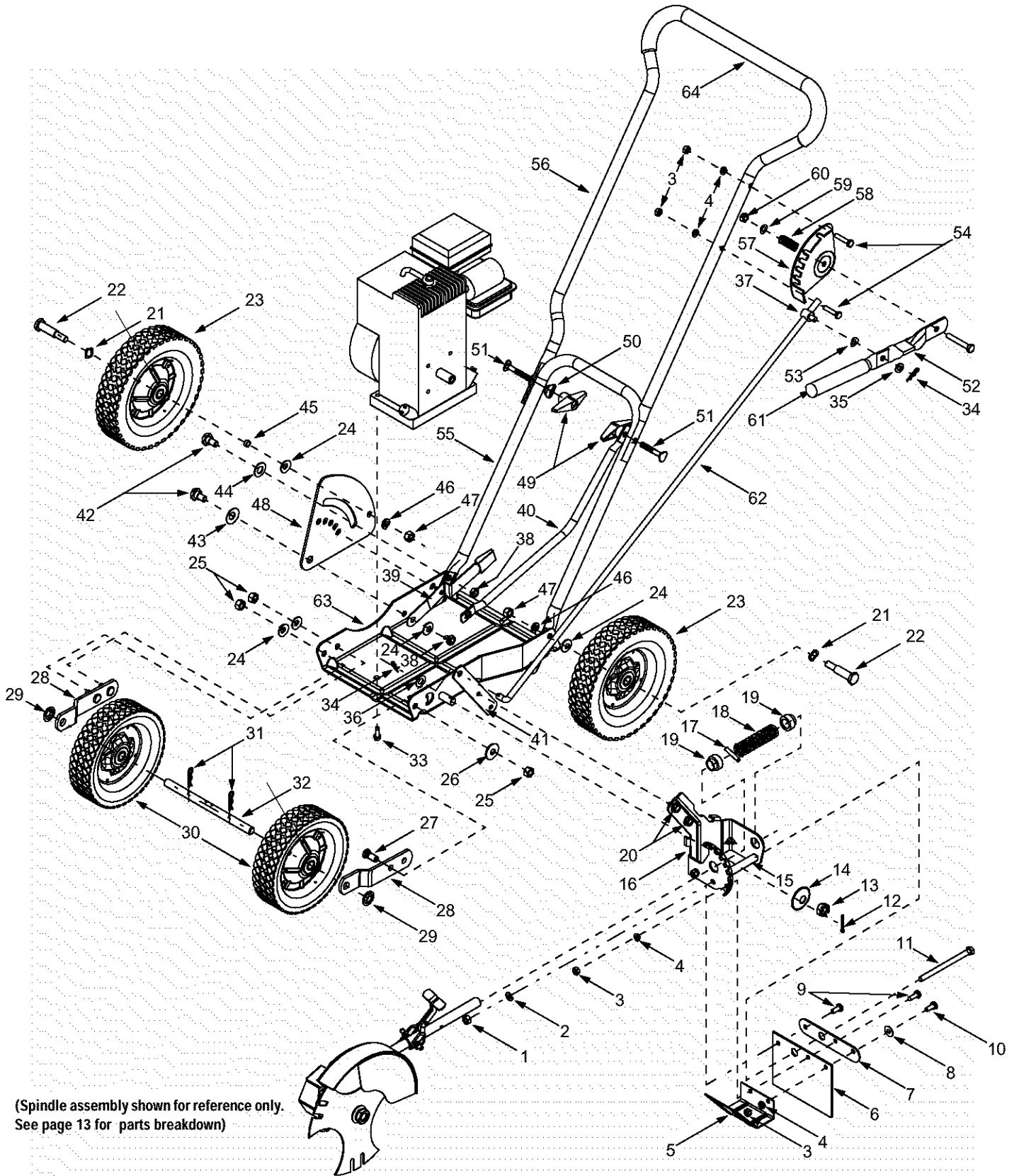

(Spindle assembly shown for reference only.
See page 13 for parts breakdown)

Model 592

Ref. No.	Part No.	Description	Ref. No.	Part No.	Description
1.	712-0267	Hex Nut, 5/16-18	33.	710-0654A	Self-tapping Screw, 3/8-16 x 1.0
2.	736-0119	Lock Washer, 5/16	34.	714-0104	Internal Cotter Pin, .072 x 1.0
3.	712-0287	Hex Nut, 1/4-20	35.	736-0264	Flat Washer, .330 x .630 x .0635
4.	736-0329	Lock Washer, 1/4	36.	736-3050	Flat Washer, .406 x .810 x .051
5.	781-0095	Debris Deflector	37.	711-0392	Adjustment Ferrule
6.	731-0725	Debris Guard	38.	712-0266	Center Lock Nut, 3/8-24
7.	781-0087	Flap Bracket, 1.12 x 5.5	39.	732-0552	Curb Adjustment Lever Assembly
8.	736-0342	Flat Washer, .283 x .75 x .030	40.	749-0941	Support Strut, 15.91
9.	710-0252	Hex Screw w/ Nose, 1/4-20 x .85	41.	781-0075	Spindle Extension Arm
10.	710-0751	Hex Screw, 1/4-20 x .62	42.	738-0258	Shoulder Screw, .498 x .250
11.	710-0402	Hex Screw, 5/16-18 x 4.5	43.	736-0255	Bell Washer, .51 x 1.14 x .040
12.	714-0115	Cotter Pin, 1/8 x 1.0	44.	736-0272	Flat Washer, .51 x 1.0 x .060
13.	712-0114	Slotted Hex Nut, 1/2-20	45.	750-0535	Spacer, .376 x .625 x .22
14.	736-0112	Sphere Washer, .531 x 1.6 x .045	46.	736-0169	Lock Washer, 3/8
15.	711-0386	Spacer, .38 x .50 x 3.75	47.	712-0798	Hex Nut, 3/8-16
16.	781-0090	Spindle Pivot Bracket Assembly	48.	781-0100	Curb Height Adjustment Plate
17.	715-0143	Spirol Pin, 1/4 x 1.25	49.	720-0241	Wing Knob Assembly
18.	732-0187	Compression Spring	50.	736-0451	Saddle Washer, .320 x .93
19.	711-0379	Shoulder Spacer, .635 x .620	51.	710-1174	Carriage Bolt, 5/16-18 x .75
20.	710-0607	Self-tapping Screw, 5/16-18 x .50	52.	749-0666	Blade Clutch/Depth Control Lever
21.	736-0504	Wave Washer, .510 x .75 x .017	53.	736-0271	Spring Washer, .317 x .625 x .099
22.	738-0108	Shoulder Screw, .498 x 1.45	54.	710-3103	Hex Cap Screw, 5/16-18 x 2.0
23.	734-1268	Wheel w/ Ball Bearing, 8 x 1.75	55.	749-0937	Lower Handle
24.	736-0105	Spring Washer, .401 x .871 x .063	56.	749-0936A	Upper Handle (Loop Style)
25.	712-0241	Hex Nut, 3/8-24	57.	781-0081	Depth Adjustment Bracket
26.	736-0452	Bell Washer, .396 x 1.14 x .095	58.	732-0369	Compression Spring, .55 x 1.37
27.	710-0793	Rd Hd Bolt 3/8-24 x .89	59.	736-0204	Flat Washer, .344 x .62 x .030
28.	781-1069	Front Axle Arm	60.	712-0158	Hex Lock Nut, 5/16-18
29.	726-0221	Cap Speed Nut, 1/2	61.	720-0283	Foam Grip (Blade Clutch Lever)
30.	734-1264	Wheel w/ Ball Bearing, 7 x 1.75	62.	747-1164	Clutch Rod, 3/8 x 33.5
31.	714-0101	Internal Cotter Pin, .08 x 1.42	63.	681-0044	Edger Base
32.	738-1176	Front Axle, .50 x 7.98	64.	720-0297	Foam Grip (Upper Handle), 20

MANUFACTURER'S LIMITED WARRANTY FOR:



The limited warranty set forth below is given by Troy-Bilt LLC with respect to new merchandise purchased and used in the United States, its possessions and territories.

Troy-Bilt LLC warrants this product against defects for a period of two (2) years commencing on the date of original purchase and will, at its option, repair or replace, free of charge, any part found to be defective in materials or workmanship. This limited warranty shall only apply if this product has been operated and maintained in accordance with the Operator's Manual furnished with the product, and has not been subject to misuse, abuse, commercial use, neglect, accident, improper maintenance, alteration, vandalism, theft, fire, water, or damage because of other peril or natural disaster. Damage resulting from the installation or use of any accessory or attachment not approved by Troy-Bilt LLC for use with the product(s) covered by this manual will void your warranty as to any resulting damage.

Normal wear parts or components thereof are subject to separate terms as follows: All normal wear parts or component failures will be covered on the product for a period of 90 days regardless of cause. After 90 days, but within the two year period, normal wear part failures will be covered ONLY IF caused by defects in materials or workmanship of OTHER component parts. Normal wear parts and components include, but are not limited to: batteries, belts, blades, blade adapters, grass bags, rider deck wheels, seats, snow thrower skid shoes, shave plates, auger spiral rubber, and tires.

HOW TO OBTAIN SERVICE: Warranty service is available, WITH PROOF OF PURCHASE, through your local authorized service dealer. To locate the dealer in your area, check your Yellow Pages, or contact Troy-Bilt LLC at P.O. Box 361131, Cleveland, Ohio 44136-0019, or call 1-866-840-6483 or 1-330-558-7220, or log on to our Web site at www.troybilt.com.

This limited warranty does not provide coverage in the following cases:

- a. The engine or component parts thereof. These items carry a separate manufacturer's warranty. Refer to applicable manufacturer's warranty for terms and conditions.
- b. Log splitter pumps, valves, and cylinders have a separate one year warranty.
- c. Routine maintenance items such as lubricants, filters, blade sharpening, tune-ups, brake adjustments, clutch adjustments, deck adjustments, and normal deterioration of the exterior finish due to use or exposure.
- d. Troy-Bilt LLC does not extend any warranty for products sold or exported outside of the United States, its possessions and territories, except those sold through Troy-Bilt LLC's authorized channels of export distribution.
- e. Parts that are not genuine Troy-Bilt parts are not covered by this warranty.
- f. Service completed by someone other than an authorized service dealer is not covered by this warranty.
- g. Transportation charges and service calls are not covered.

No implied warranty, including any implied warranty of merchantability of fitness for a particular purpose, applies after the applicable period of express written warranty above as to the parts as identified. No other express warranty, whether written or oral, except as mentioned above, given by any person or entity, including a dealer or retailer, with respect to any product, shall bind Troy-Bilt LLC. During the period of the warranty, the exclusive remedy is repair or replacement of the product as set forth above.

The provisions as set forth in this warranty provide the sole and exclusive remedy arising from the sale. Troy-Bilt LLC shall not be liable for incidental or consequential loss or damage including, without limitation, expenses incurred for substitute or replacement lawn care services or for rental expenses to temporarily replace a warranted product.

Some states do not allow the exclusion or limitation of incidental or consequential damages, or limitations on how long an implied warranty lasts, so the above exclusions or limitations may not apply to you.

In no event shall recovery of any kind be greater than the amount of the purchase price of the product sold. **Alteration of safety features of the product shall void this warranty.** You assume the risk and liability for loss, damage, or injury to you and your property and/or to others and their property arising out of the misuse or inability to use the product.

This limited warranty shall not extend to anyone other than the original purchaser or to the person for whom it was purchased as a gift.

HOW STATE LAW RELATES TO THIS WARRANTY: This limited warranty gives you specific legal rights, and you may also have other rights which vary from state to state.

Troy-Bilt LLC, P.O. BOX 361131 CLEVELAND, OHIO 44136-0019; Phone: 1-866-840-6483, 1-330-558-7220