

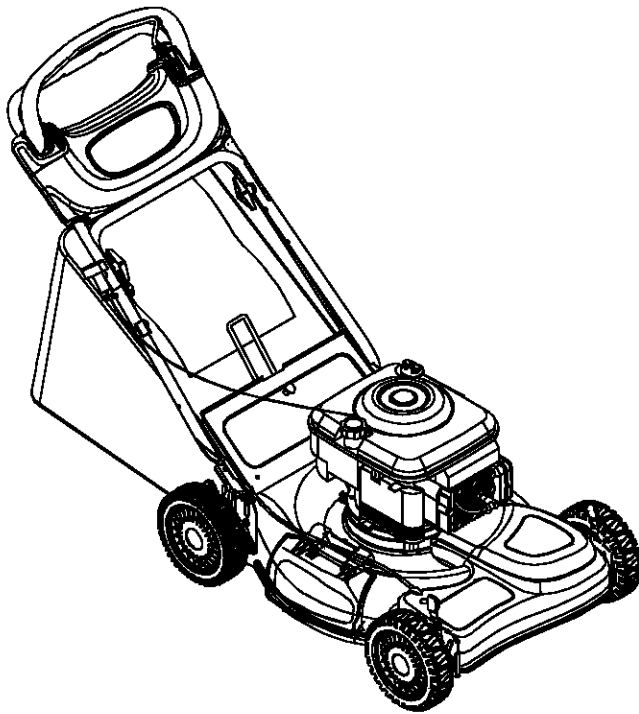

Operator's Manual



21" Three-in-One Smart Speed Lawn Mower

Model 466

IMPORTANT: Read safety rules and instructions carefully before operating equipment.

Warning: This unit is equipped with an internal combustion engine and should not be used on or near any unimproved forest-covered, brush-covered or grass-covered land unless the engine's exhaust system is equipped with a spark arrester meeting applicable local or state laws (if any). If a spark arrester is used, it should be maintained in effective working order by the operator. In the State of California the above is required by law (Section 4442 of the California Public Resources Code). Other states may have similar laws. Federal laws apply on federal lands. A spark arrester for the muffler is available through your nearest engine authorized service dealer or contact the service department, P.O. Box 361131 Cleveland, Ohio 44136-0019.

TROY-BILT LLC. P.O. BOX 361131, CLEVELAND, OHIO 44136-0019

SECTION 1: IMPORTANT SAFE OPERATION PRACTICES



WARNING: This symbol points out important safety instructions which, if not followed, could endanger the personal safety and/or property of yourself and others. Read and follow all instructions in this manual before attempting to operate this machine. Failure to comply with these instructions may result in personal injury. When you see this symbol—HEED ITS WARNING.



WARNING: Engine exhaust, some of its constituents, and certain vehicle components contain or emit chemicals known to State of California to cause cancer and birth defects or other reproductive harm.



WARNING: This machine was built to be operated according to the rules for safe operation in this manual. As with any type of power equipment, carelessness or error on the part of the operator can result in serious injury. This machine is capable of amputating hands and feet and throwing objects. Failure to observe the following safety instructions could result in serious injury or death.

General Operation

1. Read this operator's manual carefully in its entirety before attempting to assemble this machine. Read, understand, and follow all instructions on the machine and in the manual(s) before operation. Be completely familiar with the controls and the proper use of this machine before operating it. Keep this manual in a safe place for future and regular reference and for ordering replacement parts.
2. This machine is a precision piece of power equipment, not a plaything. Therefore, exercise extreme caution at all times. Your unit has been designed to perform one job: to mow grass. Do not use it for any other purpose.
3. Never allow children under 14 years old to operate this machine. Children 14 years old and over should read and understand the operation instructions and safety rules in this manual and should be trained and supervised by a parent. Only responsible individuals who are familiar with these safe operation rules should use this machine.
4. Thoroughly inspect the area where equipment is to be used. Remove all stones, sticks, wire, bones, toys and other foreign objects which could be tripped over or picked up and thrown by the blade. Thrown objects can cause serious personal injury. Plan your mowing pattern to avoid discharge of material toward roads, sidewalks, bystanders and the like. Also, avoid discharging material against a wall or obstruction which may cause discharged material to ricochet back toward the operator.
5. To help avoid blade contact or a thrown object injury, stay in the operator zone behind the handles and keep bystanders, helpers, children and pets at least 75 feet from the machine while it is in operation. Stop machine if anyone enters the area.
6. Always wear safety glasses to protect your eyes during equipment operation and while performing an adjustment or repair. Thrown objects which ricochet can cause serious injury to the eyes.
7. Wear sturdy, rough-soled work shoes and close-fitting slacks and shirts. Shirts and pants that cover the arms and legs and steel-toed shoes are recommended. Never operate this machine in bare feet, sandals, slippery or light weight (e.g. canvas) shoes.
8. Do not put hands or feet near rotating parts or under the cutting deck. Contact with the blade can amputate hands and feet.
9. A missing or damaged discharge cover can cause blade contact or thrown object injuries.
10. Many injuries occur as a result of the mower being pulled over the foot during a fall caused by slipping or tripping. Do not hold on to the mower if you are falling; release the handle immediately.
11. Never pull the mower back toward you while you are walking. If you must back the mower away from a wall or obstruction first look down and behind to avoid tripping and then follow these steps:
 - a. Step back from the mower to fully extend your arms.
 - b. Be sure you are well balanced with sure footing.
 - c. Pull the mower back slowly, no more than half way toward you.
 - d. Repeat these steps as needed.
12. Do not operate the mower while under the influence of alcohol or drugs.
13. Do not engage the self-propelled mechanism on units so equipped while starting engine.
14. The blade control handle is a safety device. Never attempt to bypass its operation. Doing so makes the safety device inoperative and may result in personal injury through contact with the rotating blade. The blade control handle must operate easily in both directions and automatically return to the disengaged position when released.
15. Never operate the mower in wet grass. Always be sure of your footing. A slip and fall can cause serious personal injury. If you feel you are losing your footing, release the blade control handle

immediately and the blade will stop rotating within three seconds.

16. Mow in daylight or good artificial light. Walk, never run. Stop the blade when crossing gravel drives, walkways or roads.
17. If the equipment should start to vibrate abnormally, stop the engine and check immediately for the cause. Vibration is generally a warning of trouble.
18. Shut the engine off and wait until the blade comes to a complete stop before removing the grass catcher or unclogging the chute. The cutting blade continues to rotate for a few seconds after the engine is shut off. Never place any part of the body in the blade area until you are sure the blade has stopped rotating.
19. Never operate mower without proper trail shield, discharge cover, grass catcher, blade control handle or other safety protective devices in place and working. Never operate mower with damaged safety devices. Failure to do so can result in personal injury.
20. Muffler and engine become hot and can cause a burn. Do not touch.
21. Only use parts and accessories made by the original equipment manufacturer (O.E.M). Failure to do so can result in personal injury.
22. If situations occur which are not covered in this manual, use care and good judgment. Contact your dealer for assistance. Telephone 1-866-840-6483 for the name of your nearest dealer.

Slope Operation

Slopes are a major factor related to slip and fall accidents which can result in severe injury. Operation on slopes requires extra caution. If you feel uneasy on a slope, do not mow it. Before operating this unit on a slope or hilly area, use the slope gauge on page 6 to measure slopes. If the slope is greater than 15 degrees, do not mow it.

Do:

1. Mow across the face of slopes; never up and down. Exercise extreme caution when changing direction on slopes.
2. Watch for holes, ruts, rocks, hidden objects, or bumps which can cause you to slip or trip. Tall grass can hide obstacles.
3. Always be sure of your footing. A slip and fall can cause serious personal injury. If you feel you are losing your balance, release the blade control handle immediately, and the blade will stop rotating within 3 seconds.

Do Not:

1. Do not mow near drop-offs, ditches or embankments; you may lose your footing or balance.
2. Do not mow slopes greater than 15 degrees as shown on the slope gauge.

3. Do not mow on wet grass. Unstable footing could cause slipping.

Children

Tragic accidents can occur if the operator is not alert to the presence of children. Children are often attracted to the mower and the mowing activity. They do not understand the dangers. Never assume that children will remain where you last saw them.

1. Keep children out of the mowing area and under the watchful care of a responsible adult other than the operator.
2. Be alert and turn mower off if a child enters the area.
3. Before and while moving backwards, look behind and down for small children.
4. Use extreme care near blind corners, doorways, shrubs, trees, or other objects that may obscure your vision of a child who may run into the mower.
5. Keep children away from hot or running engines. They can suffer burns from a hot muffler.
6. Never allow children under 14 years old to operate a power mower. Children 14 years old and over should read and understand the operation instructions and safety rules in this manual and should be trained and supervised by a parent.

Service

Safe Handling of Gasoline:

1. To avoid personal injury or property damage use extreme care in handling gasoline. Gasoline is extremely flammable and the vapors are explosive. Serious personal injury can occur when gasoline is spilled on yourself or your clothes which can ignite.
2. Wash your skin and change clothes immediately.
3. Use only an approved gasoline container.
4. Never fill containers inside a vehicle or on a truck or trailer bed with a plastic liner. Always place containers on the ground away from your vehicle before filling.
5. If possible, remove gas-powered equipment from the truck or trailer and refuel it on the ground. If this is not possible, then refuel such equipment on a trailer with a portable container, rather than from a gasoline dispenser nozzle.
6. Keep the nozzle in contact with the rim of the fuel tank or container opening at all times until fueling is complete. Do not use a nozzle lock-open device.
7. Extinguish all cigarettes, cigars, pipes and other sources of ignition.
8. Never fuel machine indoors because flammable vapors will accumulate in the area.
9. Never remove gas cap or add fuel while the engine is hot or running. Allow engine to cool at least two minutes before refueling.

10. Never over fill fuel tank. Fill tank to no more than ½ inch below bottom of filler neck to provide space for fuel expansion.
11. Replace gasoline cap and tighten securely.
12. If gasoline is spilled, wipe it off the engine and equipment. Move unit to another area. Wait 5 minutes before starting the engine.
13. Never store the machine or fuel container inside where there is an open flame, spark or pilot light as on a water heater, space heater, furnace, clothes dryer or other gas appliances.
14. To reduce fire hazard, keep mower free of grass, leaves, or other debris build-up. Clean up oil or fuel spillage and remove any fuel soaked debris.
15. Allow a mower to cool at least 5 minutes before storing.

General Service:

1. Never run an engine indoors or in a poorly ventilated area. Engine exhaust contains carbon monoxide, an odorless and deadly gas.
2. Before cleaning, repairing, or inspecting, make certain the blade and all moving parts have stopped. Disconnect the spark plug wire and ground against the engine to prevent unintended starting.
3. Check the blade and engine mounting bolts at frequent intervals for proper tightness. Also, visually inspect blade for damage (e.g., bent, cracked, worn) Replace blade with the original equipment manufacturer’s (O.E.M.) blade only, listed in this manual. “Use of parts which do not meet the original equipment specifications may lead to improper performance and compromise safety!”

4. Mower blades are sharp and can cut. Wrap the blade or wear gloves, and use extra caution when servicing them.
5. Keep all nuts, bolts, and screws tight to be sure the equipment is in safe working condition.
6. Never tamper with safety devices. Check their proper operation regularly.
7. After striking a foreign object, stop the engine, disconnect the spark plug wire and ground against the engine. Thoroughly inspect the mower for any damage. Repair the damage before starting and operating the mower.
8. Never attempt to make a wheel or cutting height adjustment while the engine is running.
9. Grass catcher components, discharge cover, and trail shield are subject to wear and damage which could expose moving parts or allow objects to be thrown. For safety protection, frequently check components and replace immediately with original equipment manufacturer’s (O.E.M.) parts only, listed in this manual. “Use of parts which do not meet the original equipment specifications may lead to improper performance and compromise safety!”
10. Do not change the engine governor setting or overspeed the engine. The governor controls the maximum safe operating speed of the engine.
11. Maintain or replace safety and instruction labels, as necessary.
12. Observe proper disposal laws and regulations. Improper disposal of fluids and materials can harm the environment.

Your Responsibility

- Restrict the use of this power machine to persons who read, understand and follow the warnings and instructions in this manual and on the machine.



SECTION 2: SLOPE GAUGE

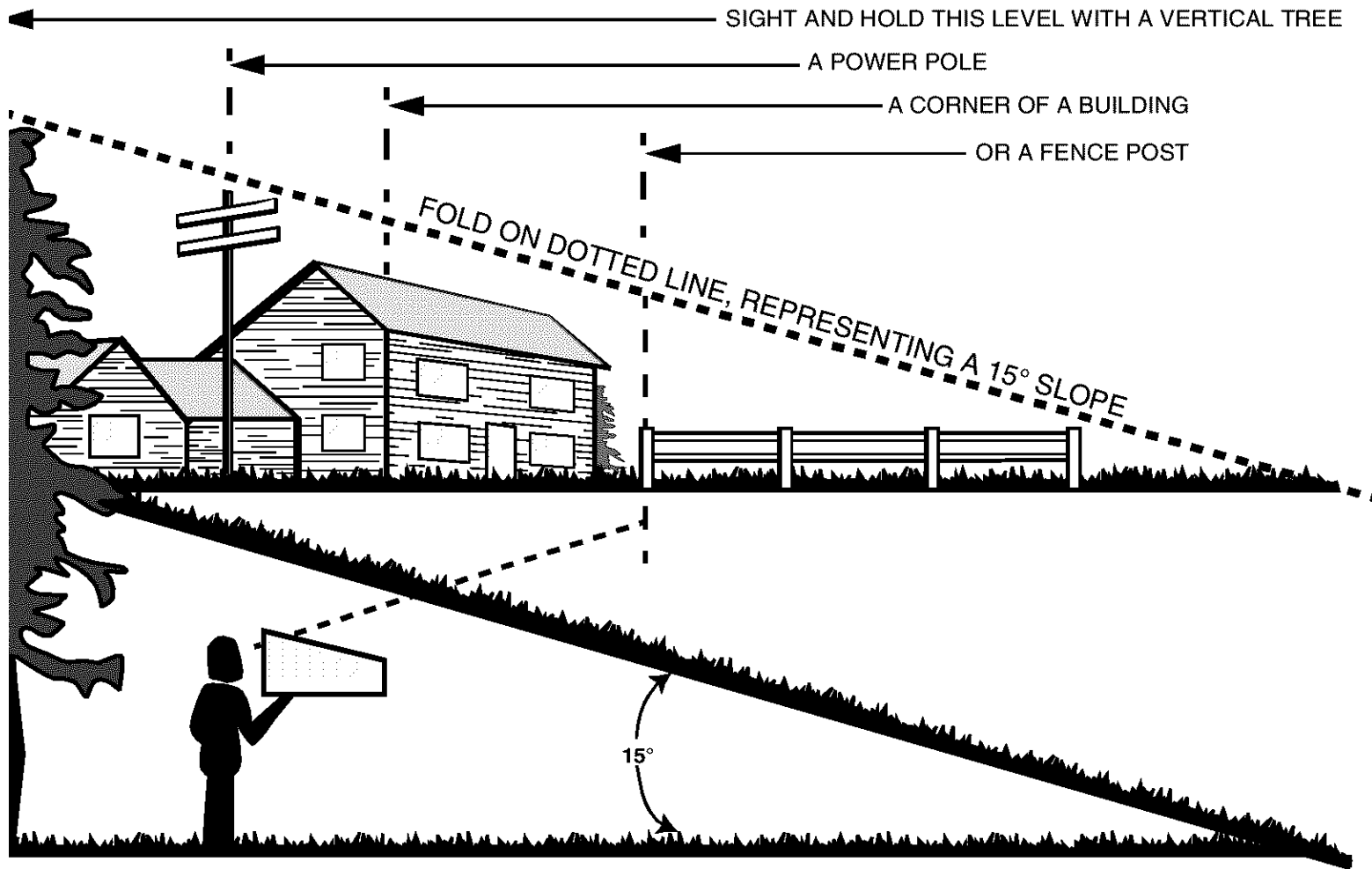

WARNING

Do not mow on inclines with a slope in excess of 15 degrees (a rise of approximately 2-1/2 feet every 10 feet). A riding mower could overturn and cause serious injury. If operating a walk-behind mower on such a slope, it is extremely difficult to maintain your footing and you could slip, resulting in serious injury.

Operate RIDING mowers up and down slopes, never across the face of slopes.

Operate WALK-BEHIND mowers across the face of slopes, never up and down slopes.

SECTION 3: ASSEMBLING YOUR LAWN MOWER

Removing Unit From Carton

- Remove staples, break glue on top flaps or cut tape at carton end and peel along top flap to open carton.
- Remove loose parts if included with unit (i.e., operator's manual, hardware pack etc.).
- Cut corners and lay carton down flat. Remove packing material.
- Roll or slide unit out of carton. Check carton thoroughly for loose parts.

NOTE: Make sure not to crimp cables while removing loose parts or the entire unit from the carton.

Tools Required

- Pair of Pliers
- Funnel
- Set of adjustable wrenches

Disconnecting Spark Plug

- Before setting up your lawn mower, disconnect the spark plug wire from the spark plug, and ground it to a bolt. See Figure 1 .

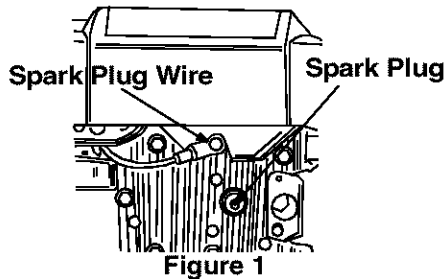

NOTE: Reference to right or left hand side of the mower is observed from the operating position.

Assembling Handle

- For shipping purposes, the grass bag was placed on top of the unit. Remove it from the unit and set it out of the way. See Figure 2 .

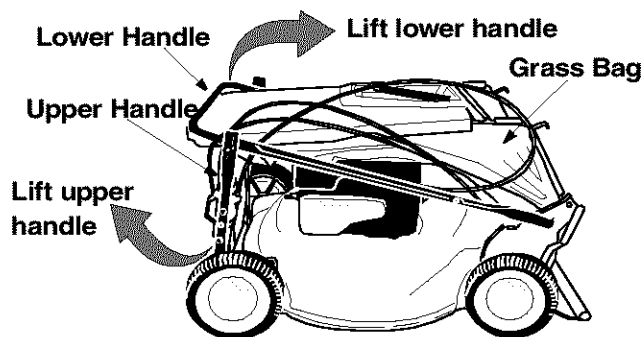

Figure 2

- Raise the lower handle, as shown in Figure 2 , till it snaps into place.
- Raise the upper handle as shown in Figure 2 .
- Tighten the two wing nuts which are already on the handle. See Figure 3 .

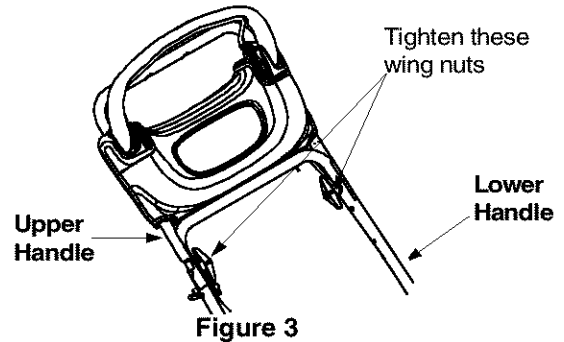

Figure 3

NOTE: Make sure to route the cables outside the lower handle. Also do not crimp the cables while lifting the handle up.

- Pull the drive control handle all the way back.
- While holding the drive control handle, hook the "Z" end of the drive cable into the bottom hole of the drive control handle from inside to outside. See Figure 4 .

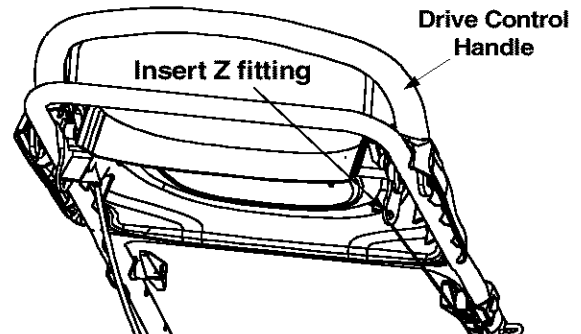

Figure 4

- Remove the hairpin clip from the outer hole of the weld pins on the handle mounting brackets.
- Using a pair of pliers, insert the hairpin clip into the inner hole in the weld pin. Repeat on the other side. See Figure 5 .

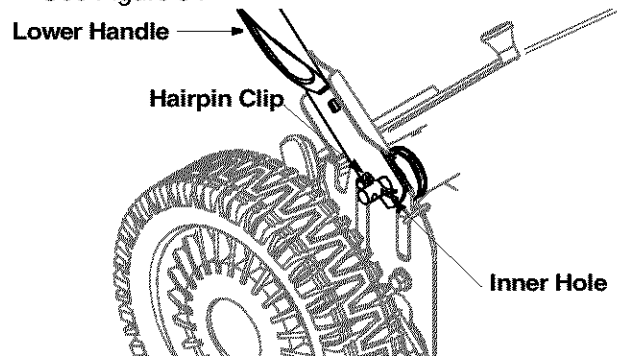

Figure 5

- Insert post of cable ties that are on lower handle into the holes provided on the lower handle. The holes may be on the inside or outside. Pull cable ties tight and cut off the extra. See Figure 6 .

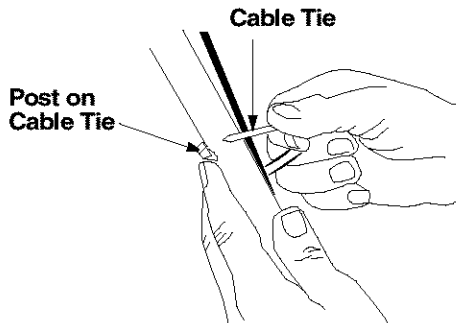

Figure 6

Attaching Drive Adjuster Block

The drive adjuster block is attached to the drive cable.

- Remove bolt attached to the lower right handle.
- Align the drive adjuster block, curved side against handle, with hole in handle.
- Secure drive adjuster block with bolt previously removed. See Figure 7 .

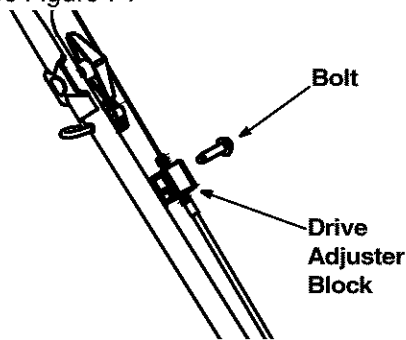

Figure 7

Attaching Starter Rope

The rope guide is already attached to the right side of the lower handle of your mower. See Figure 8 .

- With the spark plug wire disconnected and grounded, hold the blade control handle against the upper handle, and pull the starter rope up to the rope guide. See Figure 8 .
- Slip the rope through the rope guide as shown below. Tighten the wing nut holding the rope guide to the lower handle.

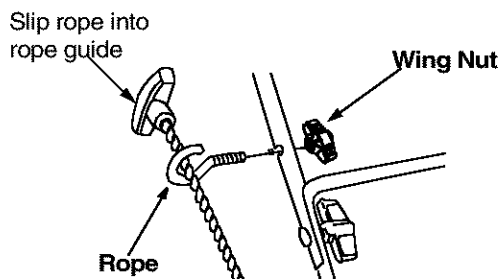

Figure 8

Grass Catcher Assembly

If the grass catcher is not already assembled, follow the steps below to assemble it. Otherwise go to the next sub-section on Attaching Grass Catcher.

NOTE: Make certain the grass bag is turned right side out before assembling (warning label will be on the outside).

Parts for Grass Bag

1. Front Frame
2. Rear Frame
3. Bag

Assembling Grass Bag

- Join the rear frame and front frame assembly as shown in Figure 9A.
- Place the bag over the frame (black plastic side is the bottom of bag). Slip the openings in the side of the plastic channels on the bag over the hooks on the grass catcher frame.
- Secure bag to frame by working the plastic channels on bag over frame as shown in Figure 9B. All of the plastic channels except the center top of the bag attach from the outside of bag. The center top of the bag attaches from inside the bag.

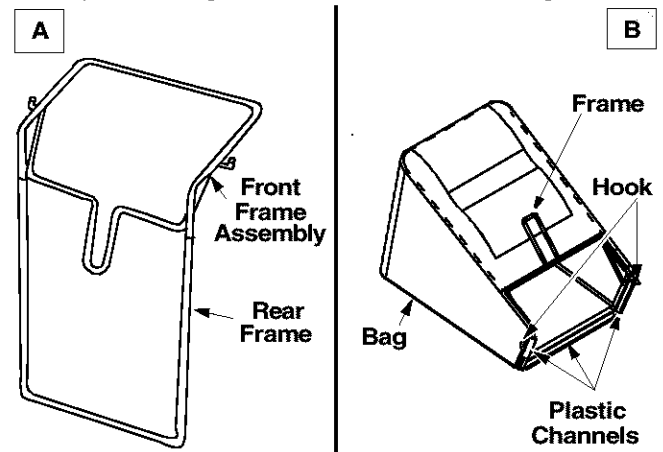

Figure 9

Attaching Grass Catcher

- If your mower is equipped with a rear baffle, and it is in place on the mower, lift the rear discharge door and remove it from the mower. See Figure 10 .

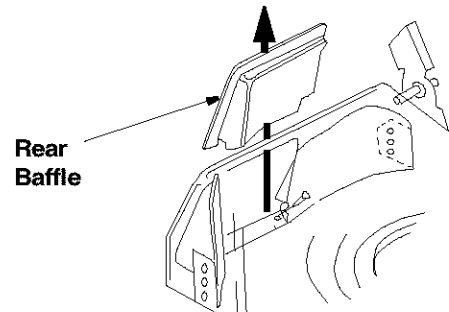

Figure 10

NOTE: Make sure that the cables are routed to the outside of the handle when attaching the grass catcher.

- Lift the rear discharge door.
- Place the hooks of the grass catcher into the slots in the handle bracket assemblies on both sides. See Figure 11 . Release the rear discharge door.

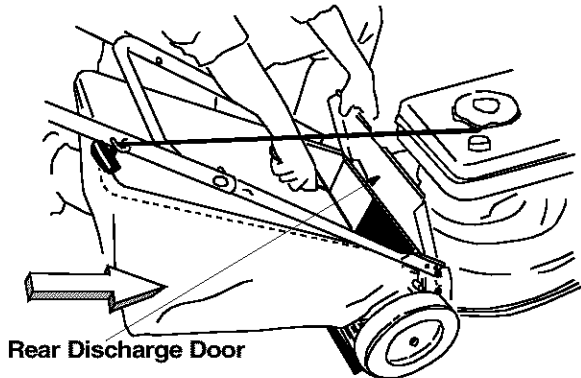

Figure 11

Removing Grass Catcher

- Lift the rear discharge door on the mower.
- Lift the grass catcher up, out of the slots in the handle bracket assemblies.
- Reinstall the plastic rear baffle.
- Release the rear discharge door.



WARNING: Never operate the mower unless the hooks on the grass catcher are seated in the slots on the handle bracket assemblies, and the rear discharge door rests firmly against the top of the grass catcher.

- Your mower has been shipped as a mulcher. To convert it to a side-discharge mower, lift the mulching plug. Slide the two hooks on the side-discharge deflector under the hinge pin on the mulching plug assembly. Lower the mulching plug. See Figure 12 .
- Do not remove the side mulching plug at any time, even when you are not mulching.

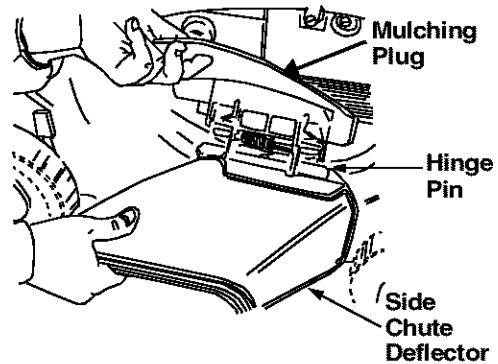
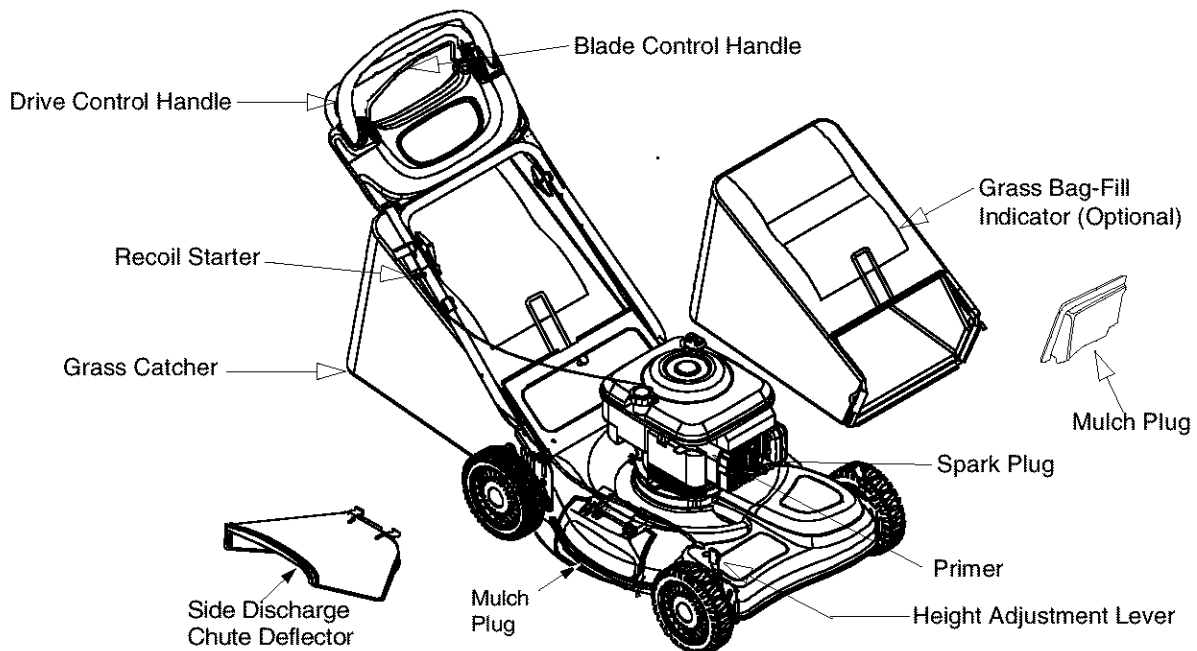

Figure 12

Converting to Side Discharge

SECTION 4: KNOW YOUR LAWN MOWER

Read this owner's manual and safety rules before operating your lawn mower. Compare the illustration below with your lawn mower to familiarize yourself with the location of various controls and adjustments.



Recoil Starter

The recoil starter is attached to the handle. Stand behind the unit and pull the starter rope to start the unit.

Primer

The primer is used to pump gas into the carburetor. Use it to assist in starting a cold engine, but do not use it when restarting a warm engine after a short shutdown. Refer to engine manual for location of the primer.

Blade Control Handle

The blade control handle is located on the upper handle of the mower. The blade control handle must be depressed in order to operate the unit. Release the blade control handle to stop the engine and the blade.



WARNING: The blade control handle is a safety device. Never attempt to bypass its operations. The blade will be rotating whenever the engine is running.

Throttle Control

The engine is equipped with a constant speed throttle which is set at full throttle for maximum engine and cutting performance.

Grass Bag/Bag-Fill Indicator

The grass bag is equipped with a bag-fill indicator to add convenience to your work. While the mower is running, air will flow through the bag and into the "sail." If the grass catcher is **empty**, air flows through easily pushing the sail up. If the grass catcher is **full**, air does not flow through it allowing the sail to fall. So the position of the sail acts as a bag-fill indicator signifying when to empty the grass bag.

Drive Control Handle

The drive control handle is located on the upper handle and is used to engage the drive. Pushing the handle forward will engage the drive. The farther the handle is pushed forward, the faster the mower will propel. Pulling the drive control handle backwards will slow down or stop the mower.

SECTION 5: OPERATING YOUR LAWN MOWER

Gas and Oil Fill-Up



WARNING: Never fill fuel tank indoors, or when engine is running or hot. Do not smoke when filling up the fuel tank.

- Service the engine with gasoline and oil as instructed in the separate engine manual packed with your mower. Read the instructions carefully.

Before Starting Mower

- Attach spark plug wire to spark plug. Make certain the metal cap on the end of the spark plug wire (inside the rubber boot) is fastened securely over the metal tip on the spark plug.

Starting Engine



WARNING: Be sure no one other than the operator is standing near the lawn mower while starting engine or operating mower.

WARNING: Never run engine indoors or in enclosed, poorly ventilated areas. Engine exhaust contains carbon monoxide, an odorless and deadly gas.

WARNING: Keep hands, feet, hair and loose clothing away from any moving parts on engine and lawn mower.

- Push the primer three times. Wait two seconds between each push. In temperatures below 55° F, prime five times. Do not prime to restart a warm engine after a short shutdown.
- Standing behind the mower, depress the blade control handle and hold it against the upper handle.
- Grasp starter handle and pull rope out slowly until engine reaches start of compression cycle (rope will pull slightly harder at this point). Let the rope rewind slowly. Pull rope with a rapid, continuous, full arm stroke. Keeping a firm grip on the starter handle, let the rope rewind slowly.
- Once the engine has started, squeeze the lower bail handle and the blade control handle against the upper handle to run the mower.

Stopping Engine

- Release blade control handle to stop the engine and the blade.
- Disconnect spark plug wire and move away from spark plug to prevent accidental starting.

Using Your Lawn Mower

- **Do not** operate the mower without the mulching cover, the grass catcher bag, or the discharge chute properly installed.
- Be sure that the lawn is clear of stones, sticks, wire, or other objects which could damage lawn mower or engine. Such objects could be accidentally thrown

by the mower in any direction and cause serious personal injury to the operator and others.

- For best results, *do not cut wet grass* because it tends to stick to the underside of the mower, preventing proper discharge of grass clippings, poor mulching conditions, and could cause you to slip and fall. New grass, thick grass, or wet grass may require a narrower cut.
- For a *healthy lawn*, always cut off one-third or less of the total length of the grass. Lawn should be trimmed in fall as long as there is growth.



WARNING: If you strike a foreign object, stop the engine. Remove spark plug wire from spark plug, thoroughly inspect the mower for any damage. Repair the damage before restarting and operating the mower. Extensive vibration of the mower during operation is an indication of damage. The unit should be promptly inspected and repaired.

Adjusting Cutting Height

Refer to page 13 for instruction on how to adjust the cutting height and the handle height.

- For best results in mowing, keep the cutting height position high until you have determined which cutting height is preferred.

Bagging Grass Clippings

You can use the grass catcher bag to collect clippings while you are operating the mower.

- Attach the grass catcher following instructions on page 8 of this manual. The grass clippings will automatically collect in the bag as you run the mower.
- Operate the mower till the grass bag is full. Refer to page 10 for description of bag-fill indicator.
- Stop the engine completely by releasing the control handle.
- Make sure that the unit has come to a complete stop.
- Lift discharge door and pull grass bag up and away from the mower to dispose of the grass clippings.

SECTION 6: MAINTAINING YOUR LAWN MOWER



WARNING: Always stop the engine and disconnect the spark plug wire before performing any maintenance work or adjustments on your lawn mower.



WARNING: Never tip the mower more than 90 degrees in any direction and do not leave the mower tipped for any length of time. Oil can drain into the upper part of the engine causing a starting problem.

Cleaning the Mower

- Clean the underside of the mower deck after each use to prevent any build-up of grass clippings. If this debris is allowed to accumulate, it will result in rust and corrosion.

NOTE: *We do not recommend the use of pressure washers or garden hose to clean your unit. These may cause damage to electric components, spindles, pulleys, bearings or the engine. The use of water will result in shortened life and reduced serviceability.*

- Disconnect spark plug wire.
- Drain the gasoline from the lawn mower, or place a piece of plastic under the gas cap.
- Tilt the mower so that the side with the air cleaner is facing up. Hold the mower firmly.
- Scrape and clean the underside of the deck with a suitable tool. Do not spray with water.
- Put the mower back on its wheels. If you had put

Engine Maintenance

A list of key maintenance jobs required for good performance by the mower is given below. Follow the accompanying engine manual for detailed list and instructions.

- Change engine oil after the first two operating hours and every 25 operating hours thereafter. Check oil level before starting engine every time.
- Service foam filter in the air cleaner every 25 hours of use and replace the paper filter component every 100 hours. You may have to service the air filter more frequently if you are operating the mower under extremely dusty conditions.
- Clean engine periodically with a cloth or brush.
- Clean the spark plug and reset the gap to .030" at least once a season or every 50 hours of operation. Spark plug replacement is recommended at the start of each season.

- Inspect muffler periodically, and replace if necessary. Damaged mufflers or spark arresters can create a fire hazard. Make sure to avoid muffler and surrounding areas while the mower engine is hot because temperature of these areas of the engine may exceed 150° F.

Lubrication (See Figure 13)

Wheels

- Lubricate the wheels and bearings, if so equipped, at least once a season with light oil or engine oil. Also, if the wheels are removed for any reason, lubricate the surface of the axle bolt and the inner surface of the wheel with light oil.

Chute Deflector & Rear Discharge Door

- Lubricate the torsion spring and the pivot point on each end of the chute deflector and the rear discharge door using a light oil. This will prevent rusting and ensure that the deflector, which is a safety device, can always work properly.

Engine

- Follow the engine manual instructions and recommended schedule for lubricating engine components.

Pivot Points

- Lubricate the pivot points on the blade control handle, lower bail handle, and the cutting height adjustment lever at least once a season with light oil. The blade control handle and the lower bail handle must operate freely in both directions. The cutting height adjustment levers should be able to move easily.

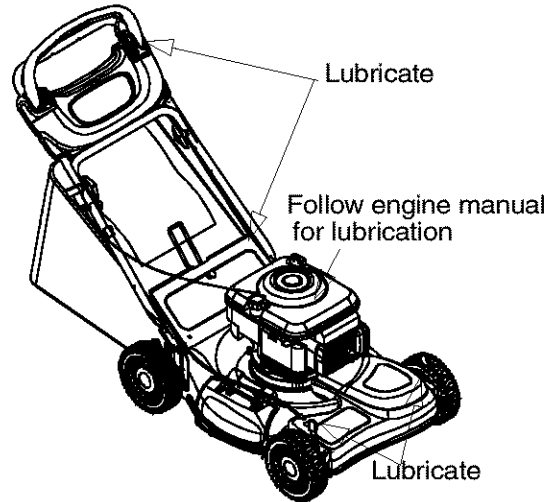

Figure 13

SECTION 7: SERVICING YOUR MOWER

Blade Care

Periodically inspect the blade adapter and pulley for cracks, especially if you strike a foreign object. Replace when necessary.



WARNING: When removing the cutting blade for sharpening or replacement, protect hands by using heavy gloves or a thick rag to grasp the cutting blade.

- Disconnect spark plug wire from spark plug.
- Turn mower on its side making sure that the air filter and the carburetor are up.

To Remove Blade

- Remove the bolt and the bell support that hold the blade-pulley assembly to the engine crankshaft. See Figure 14. Remove the assembly from the crankshaft.
- Remove the blade from blade adapter and pulley.

To Replace Blade:

- Turn mower on its side making sure that the air filter and the carburetor are up.
- Place the new blade on the blade adapter with the side marked bottom (or with part number) facing away from the adapter.

NOTE: Make sure the parts above the blade adapter are assembled as shown in Figure 14 ..

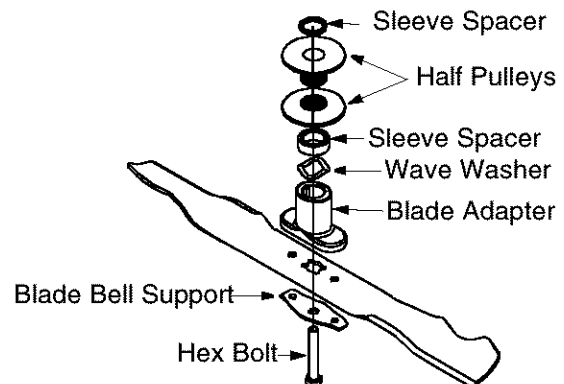

Figure 14

- Secure with the hex bolt and blade bell support and tighten to the recommended torque. Refer to 'Blade Mounting Torque' section on this page.

IMPORTANT: The bolt, used to secure the blade to the engine, is specially heat-treated. **Do not substitute.** To order replacement bolt, refer to the parts list in the back of this manual.



WARNING: To ensure safe operation of your lawn mower, check all nuts and bolts periodically and tighten if necessary.

Blade Mounting Torque:

Blade adapter bolts: 120 in.lbs. minimum, 150 in.lbs. maximum.

Center bolt: 450 in.lbs. minimum, 600 in.lbs. maximum.

To Sharpen Blade:

- The blade can be sharpened with a file or on a grinding wheel. Do not attempt to sharpen the blade while it is still on the mower.
- Follow the original angle of grind as a guide. Make sure that each cutting edge receives an equal amount of grinding to prevent an unbalanced blade.

An unbalanced blade will cause excessive vibration when rotating at high speeds, may cause damage to the mower and/or personal injury. Test the blade by balancing it on a round shaft screwdriver or a blade balancer.

- If the blade is not balanced, remove metal from the heavy side until it balances evenly.

Replacing Drive Belt

- Remove the two shoulder screws which secure the front drive cover to the mower deck. See Figure 14.
- Remove the front drive cover from the unit by lightly pressing inward on the sides of the front drive cover. This will release the tabs that secure the front drive cover to the height adjuster brackets.
- Remove the idler and accompanying hardware from the idler bracket using 7/16" wrench and socket. See Figure 14.
- Remove the belt from the transmission pulley as shown in Figure 14.
- Lift and stabilize the front of the deck.

- Loosen the center hex bolt and lower the blade and engine pulley until there is adequate clearance to move the belt past the belt keeper.
- Remove the belt from the engine pulley and around the blade. See Figure 15.
- Reassemble in reverse order with new belt.

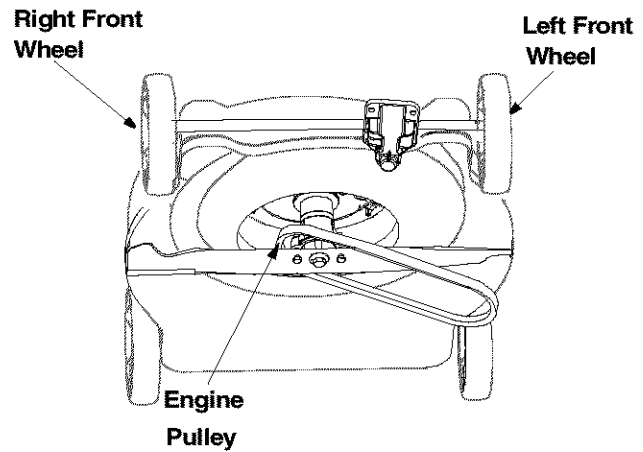

Figure 15

Replacing Rear Flap

- To remove rear flap, cut off the flat end of the wire rod which secures it to the deck. See Figure 16 .
- Attach the new flap and new rod to deck, bending the ends of the new rod over to secure to deck.

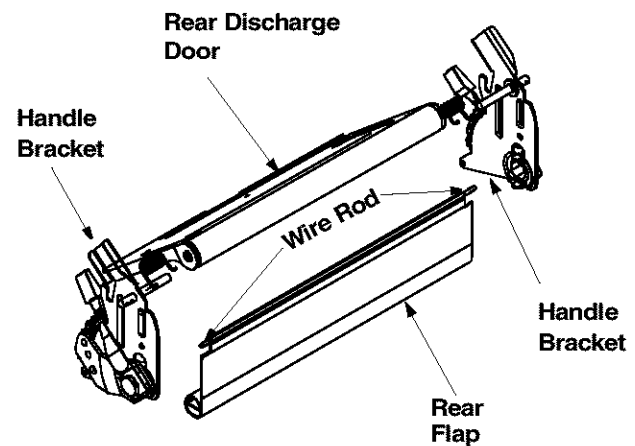

Figure 16

SECTION 8: MAKING ADJUSTMENTS

Handle Height

Your mower is shipped with the handle in the higher height position. To lower height, proceed as follows.

- Remove the starter rope from the rope guide.

- Remove the upper handle by removing the hand knobs and carriage bolts. Lay the upper handle out of the way, being careful not to bend or kink cables.

- Remove the hairpin clips from the weld pins on the handle brackets. Refer to Figure 4. Press out on the legs of the lower handle. Remove lower handle from the mower.
- Turn lower handle around so the notch is facing forward as shown in Figure 17 . Reassemble, placing the bottom holes in the handle over the weld pins in the handle mounting bracket.
- Reassemble the upper handle to the lower handle.
- Insert hairpin clips in the inner holes of the weld pins and attach the starter rope as instructed in “Assembling Your Lawn Mower” section.

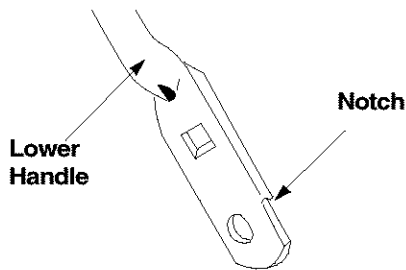

Figure 17

Drive Clutch Adjustment

The drive clutch adjustment wheel is located on the lower right handle and is used to tighten or loosen tension on the drive cable. Perform this adjustment if the following exists.

- The mower does not propel itself or the wheels hesitate with the drive control handle pushed forward.

To resolve the above problem, rotate the adjustment wheel with your fingers. See Figure 18 .

- Turning the wheel to the left will tighten the drive cable.

- Turning the wheel to the right will loosen the drive cable.

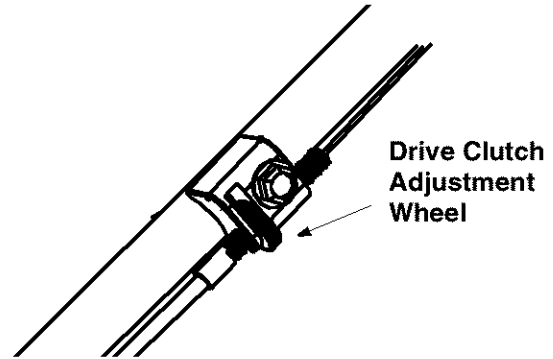

Figure 18

Cutting Height

IMPORTANT: All wheels must be placed in the same relative position.

- For rough or uneven lawns, move the height adjustment lever to a higher position. This will help stop scalping of the grass.

An adjusting plate and thumb lever at each wheel position provides cutting height adjustment. Each adjusting plate has nine height positions. Height of cut will change when you move the thumb lever from one position to another.

- Simply depress the lever towards the wheel and move the lever assembly to desired position. See Figure 19 .

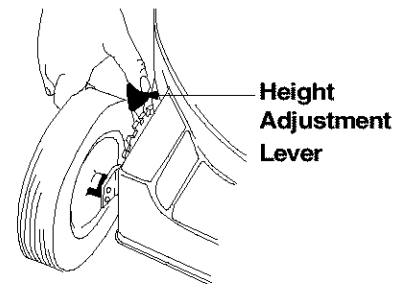

Figure 19

SECTION 9: OFF-SEASON STORAGE

Prepare your lawn mower for storage at the **end of the season** or if it will not be used for **30 days or more**.

Mower

- Clean underside of the mower following instructions on page 11.

NOTE: We do not recommend the use of pressure washers or garden hose to clean your unit. They may cause damage to electric components, spindles, pulleys, bearings or the engine. The use of water will result in shortened life and reduce serviceability.

- Lubricate the mower as instructed on page 12.
- You can fold your mower’s handle for convenience of storage:

Remove the starter rope from the rope guide; loosen the two hand knobs on the sides of the handle, and let the upper handle fold down to the rear. Move the hairpin clips to the outer hole in the weld pins on the handle mounting brackets. Spread sides of the lower handle, and push it forward and down.

- Inspect and replace/sharpen blade, if required. Refer to page 12.

Gasoline

- Do not store gasoline from one season to another.

NOTE: Gasoline, stored for more than one month, may affect engine performance. So use fresh gasoline.

- Replace your gasoline can if it starts to rust. Rust and/or dirt in the gasoline will cause problems.

Engine

- Clean engine and remove any grass clippings, dirt, and debris from the cooling fins, air intake screen, levers, linkage and the exterior of the engine.
- Follow recommendations in engine manual for off-season storage of the engine.
- Change oil as stated in the engine manual.

Storage

- Store unit in a clean, dry area. Do not store next to corrosive materials, such as fertilizer or rocksalt.
- If storing the mower in an unventilated or metal storage shed, make sure to rustproof the equipment with a light oil or silicone.

SECTION 10: TROUBLE-SHOOTING GUIDE

Problem	Possible Cause	Corrective Action
Engine fails to start	<ol style="list-style-type: none"> 1. Blade control handle disengaged 2. Spark plug wire disconnected 3. Fuel tank empty, or stale fuel 4. Blocked fuel line 5. Faulty spark plug 6. Engine flooded 	<ol style="list-style-type: none"> 1. Engage blade control handle 2. Connect wire to spark plug 3. Fill up tank with fresh gasoline 4. Clean fuel line 5. Clean, adjust gap, or replace 6. Wait a few minutes and start again
Engine runs erratic	<ol style="list-style-type: none"> 1. Spark plug wire loose 2. Blocked fuel line or stale fuel 3. Vent in gas cap plugged 4. Water or dirt in fuel system 5. Dirty air cleaner 	<ol style="list-style-type: none"> 1. Connect and tighten spark plug wire 2. Clean fuel line, fill tank with fresh gas 3. Clear vent 4. Drain fuel tank. Refill with fresh fuel 5. Clean air cleaner. Refer to engine manual
Engine overheats	<ol style="list-style-type: none"> 1. Engine oil level low 2. Air flow restricted 	<ol style="list-style-type: none"> 1. Fill crankcase with proper oil 2. Clean lawn mower engine
Occasional skip at high speed	<ol style="list-style-type: none"> 1. Spark plug gap too close 	<ol style="list-style-type: none"> 1. Adjust gap to .030 inches
Idles poorly	<ol style="list-style-type: none"> 1. Spark plug fouled, faulty, or gap too wide 2. Dirty air cleaner 	<ol style="list-style-type: none"> 1. Reset gap to .030 inches or replace spark plug 2. Clean air cleaner
Excessive vibration	<ol style="list-style-type: none"> 1. Cutting blade loose or unbalanced 2. Bent cutting blade 3. Bent engine crankshaft 	<ol style="list-style-type: none"> 1. Tighten blade and adapter, balance blade 2. Replace blade 3. Contact your nearest service center
Mower will not mulch grass	<ol style="list-style-type: none"> 1. Wet grass 2. Excessively high grass 3. Dull blade 	<ol style="list-style-type: none"> 1. Wait until grass is dry to cut 2. Mow once at a high cutting height, then mow again at desired height 3. Sharpen or replace blade
Uneven cut	<ol style="list-style-type: none"> 1. Wheels not in same height position 2. Dull blade 	<ol style="list-style-type: none"> 1. Reposition all wheels at same height 2. Sharpen or replace blade

NOTE: For repairs beyond the minor adjustments listed above, contact your nearest authorized service dealer. Refer to separate engine manual packed with your mower for more engine related information.

SECTION 11: PARTS LIST FOR MODEL 466

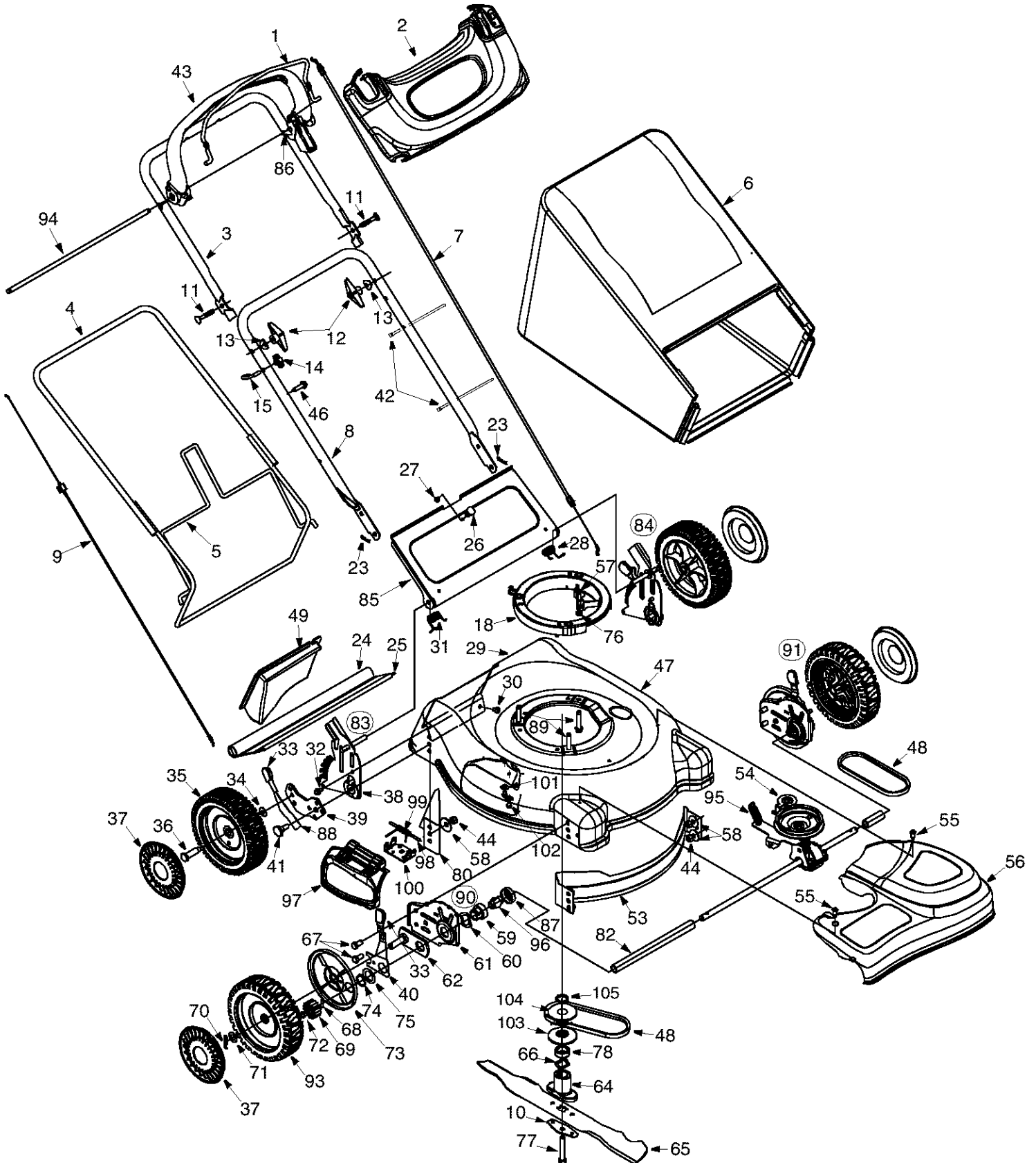

Model 466

Ref. No.	Part No.	Part Description	Ref. No.	Part No.	Part Description
1.	747-2133	Bail Handle	58.	736-0331	Bell Washer
2.	731-2628	Handle Panel	59.	748-0355	Bearing Support
3.	749-1507	Upper Handle	60.	736-0447	Wave Washer
4.	764-0310	Rear Grass Catcher Frame	61.	782-0511A	Height Adj. Plate LH†
5.	764-0311	Front Grass Catcher Frame		782-0512B	Height Adj. Plate RH
6.	664-0176	Grass Bag-Half Sail	62.	682-0509	Pivot Plate Assembly
7.	746-1252	Control Cable	63.	756-1146A	Drive Pulley
8.	749-0907B	Lower Handle	64.	748-0377C	Blade Adapter
9.	746-1250	Drive Cable	65.	742-0741	Mulching Blade w/ Star: 21"
10.	736-0524A	Blade Bell Support		742-0641	Standard Blade 21"
11.	710-1174	Carriage Bolt	66.	736-0526	Wave Washer
12.	720-0284	Handle Knob	67.	710-0216	Hex Screw 3/8-16
13.	736-0451	Saddle Washer	68.	715-0221	Dowel Pin
14.	720-0279	Wing Nut	69.	717-1762	Gear 14T RH
15.	710-1205	Rope Guide		717-1761	Gear 14T LH †
18.	631-0075B	Engine Spacer Assembly	70.	714-0101	Hairpin Clip
23.	714-0104	Hairpin Clip	71.	736-3013	Flat Washer
24.	731-1236	Rear Trail Shield	72.	716-0865	Snap Ring
25.	732-0700	Wire: Trail Shield	73.	782-7551	Wheel Dust Cap
26.	720-0275	Knob	74.	716-0102	Snap Ring
27.	710-0192	Scr. Tr. Mach. #10-24 x 0.380"	75.	736-0474	Washer DD 1.5" O.D.
28.	732-0677	Torsion Spring LH	76.	712-0271	Hex Nut 1/4-20
29.	782-5003	Rear Baffle LH	77.	710-1257	Hex Bolt
30.	710-1017	Scr. AB 1/4-14 x 0.625"	78.	750-04010	Sleeve Spacer, .88 x 1.19 O.D.
31.	732-0678	Torsion Spring RH	80.	782-5004	Rear Baffle RH
32.	710-0896	Hex Scr. w/ Wash. 1/4-14 x 0.62"	82.	750-1166	Slev. Spacer LH †
33.	720-0426	Knob		750-1165	Slev. Spacer RH
34.	736-0105	Bell Washer .375 x .870	83.	682-0516A	Handle Bracket Assembly RH Compl.
35.	734-2042	Rear Wheel: Disk Bar Gray	84.	682-0515A	Handle Bracket Assembly LH Compl.
36.	738-0102	Shoulder Screw	85.	782-7000	RD Chute Door
37.	731-0981A	Hubcap: Radial Spoke Grey	86.	731-2646	Bail Stop
38.	682-3067	Handle Bracket Assembly LH †	87.	732-0708	Bearing Retainer
	682-3066	Handle Bracket Assembly RH	88.	732-0417A	Spring Lever
39.	14766	Pivot Bar LH†	89.	710-1008	TT Screw
	14765	Pivot Bar RH	90.	682-0512A	Height Adj. Assembly RH Compl.
40.	732-0706	Front Lever RH	91.	682-0511A	Height Adj. Assembly LH Compl.
	732-0707	Front Lever LH†	93.	734-2004A	Wheel, 8x2 x 1.75
41.	738-0507B	Shoulder Screw	94.	747-2132	Control Rod
42.	726-0240	Cable Tie	95.	732-04001	Extension Spring
43.	731-2629	Drive Handle	96.	741-0604A	Bearing Sleeve .50 I.D.
44.	712-0798	Hex Nut 3/8-16	97.	731-1404A	Mulch Plug
45.	736-0356	Flat Washer	98.	747-0710	Hinge Pin
46.	710-0817	TT-Scr. 5/16-18	99.	732-0731	Torsion Spring
47.	782-0082A	Rear Discharge Deck: 21"	100.	782-7006	Mounting Brkt.
48.	754-0465	V-Belt	101.	736-0270	Bell Wash. 0.265" x 0.75"
49.	782-5007A	Mulch Plug	102.	710-0599	TT-Screw 1/4-20 x .05"
53.	782-5002	Front Baffle	103.	756-0613	Half Pulley
54.	618-04006	Transmission Assembly Compl.	104.	756-0612A	Half Pulley
55.	710-1650	Shld. Screw	105.	750-1071	Sleve Spacer .88 I.D. x 1.130 O.D.
56.	731-1936A	Front Drive Cover: Black		737-0476	Bottle of Oil (Not shown)
57.	711-1293	Belt Keeper Pin			

Model 466

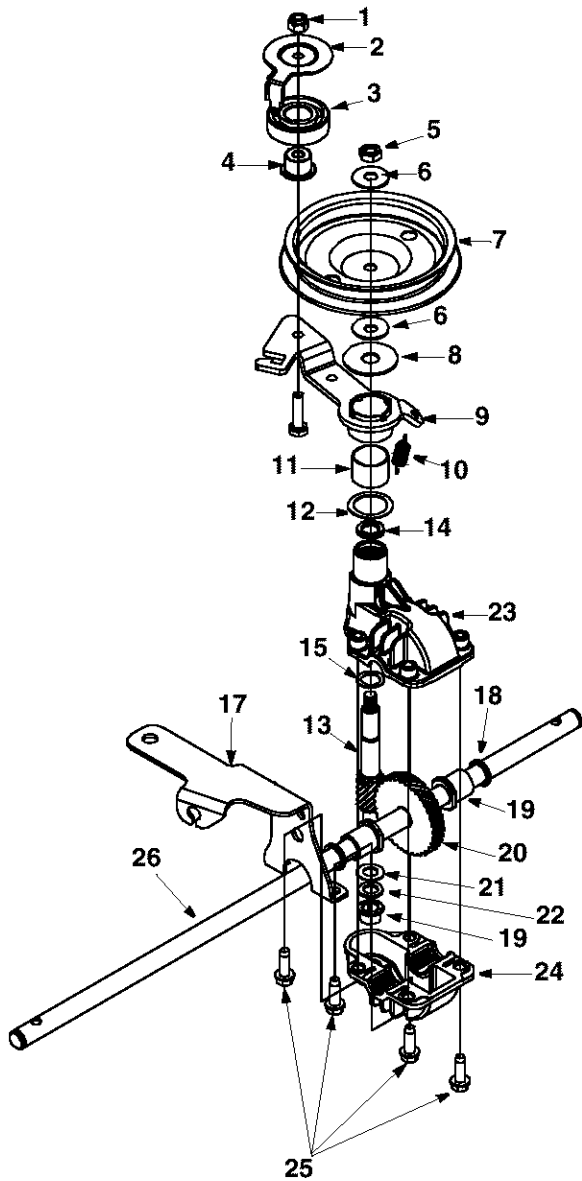

Ref No.	Part No.	Description
1.	712-0896	L-Nut 1/4-28
2.	782-7598	Belt Keeper
3.	741-0124	Ball Bearing
4.	750-1050	Flange Bearing
5.	712-3025	Hex Jam Nut 5/16-24
6.	736-0425	Bell Washer .325 x .930 x .45
7.	656-0047	Pulley, 3.82 x .313 x .68
8.	736-0406	Flat Washer .422 x 1.38 x .060
9.	682-0028	Idler Bracket Pulley
10.	732-04001	Extension Spring
11.	741-0682A	Bearing Sleeve
12.	736-0570	FI-Wash. .865 x 1.145 x .030
13.	711-1492	Pinion Shaft 10T
14.	741-0699	Needle Bearing .438 x .625 x .500
15.	736-0520	FI-Wash. .504 x .700 x .030
16.	717-1492	Pinion Shaft
17.	682-0030	Cable Idler Brkt.
18.	721-0329	Oil Seal .500 x .687 x .094
19.	741-0673	Flange Bearing
20.	611-0105	Output Shaft
21.	736-0314	Thrust Washer .375 x .070 x .030
22.	736-0569	Thrust Washer .388 x .625 x .062
23.	618-0300A	Upper Housing
24.	618-0299A	Lower Housing
25.	710-1276	Hex Screw w/Washer 1/4-20 x .750
26.	618-04006	Transmission Assembly Comp.

MANUFACTURER'S LIMITED WARRANTY FOR:



The limited warranty set forth below is given by Troy-Bilt LLC with respect to new merchandise purchased and used in the United States, its possessions and territories.

Troy-Bilt LLC warrants this product against defects for a period of two (2) years commencing on the date of original purchase and will, at its option, repair or replace, free of charge, any part found to be defective in materials or workmanship. This limited warranty shall only apply if this product has been operated and maintained in accordance with the Operator's Manual furnished with the product, and has not been subject to misuse, abuse, commercial use, neglect, accident, improper maintenance, alteration, vandalism, theft, fire, water, or damage because of other peril or natural disaster. Damage resulting from the installation or use of any accessory or attachment not approved by Troy-Bilt LLC for use with the product(s) covered by this manual will void your warranty as to any resulting damage.

Normal wear parts or components thereof are subject to separate terms as follows: All normal wear parts or component failures will be covered on the product for a period of 90 days regardless of cause. After 90 days, but within the two year period, normal wear part failures will be covered ONLY IF caused by defects in materials or workmanship of OTHER component parts. Normal wear parts and components include, but are not limited to: batteries, belts, blades, blade adapters, grass bags, rider deck wheels, seats, snow thrower skid shoes, shave plates, auger spiral rubber, and tires.

HOW TO OBTAIN SERVICE: Warranty service is available, WITH PROOF OF PURCHASE, through your local authorized service dealer. To locate the dealer in your area, check your Yellow Pages, or contact Troy-Bilt LLC at P.O. Box 361131, Cleveland, Ohio 44136-0019, or call 1-866-840-6483 or 1-330-558-7220, or log on to our Web site at www.troybilt.com.

This limited warranty does not provide coverage in the following cases:

- a. The engine or component parts thereof. These items carry a separate manufacturer's warranty. Refer to applicable manufacturer's warranty for terms and conditions.
- b. Log splitter pumps, valves, and cylinders have a separate one year warranty.
- c. Routine maintenance items such as lubricants, filters, blade sharpening, tune-ups, brake adjustments, clutch adjustments, deck adjustments, and normal deterioration of the exterior finish due to use or exposure.
- d. Troy-Bilt LLC does not extend any warranty for products sold or exported outside of the United States, its possessions and territories, except those sold through Troy-Bilt LLC's authorized channels of export distribution.
- e. Parts that are not genuine Troy-Bilt parts are not covered by this warranty.
- f. Service completed by someone other than an authorized service dealer is not covered by this warranty.
- g. Transportation charges and service calls are not covered.

No implied warranty, including any implied warranty of merchantability of fitness for a particular purpose, applies after the applicable period of express written warranty above as to the parts as identified. No other express warranty, whether written or oral, except as mentioned above, given by any person or entity, including a dealer or retailer, with respect to any product, shall bind Troy-Bilt LLC. During the period of the warranty, the exclusive remedy is repair or replacement of the product as set forth above.

The provisions as set forth in this warranty provide the sole and exclusive remedy arising from the sale. Troy-Bilt LLC shall not be liable for incidental or consequential loss or damage including, without limitation, expenses incurred for substitute or replacement lawn care services or for rental expenses to temporarily replace a warranted product.

Some states do not allow the exclusion or limitation of incidental or consequential damages, or limitations on how long an implied warranty lasts, so the above exclusions or limitations may not apply to you.

In no event shall recovery of any kind be greater than the amount of the purchase price of the product sold. **Alteration of safety features of the product shall void this warranty.** You assume the risk and liability for loss, damage, or injury to you and your property and/or to others and their property arising out of the misuse or inability to use the product.

This limited warranty shall not extend to anyone other than the original purchaser or to the person for whom it was purchased as a gift.

HOW STATE LAW RELATES TO THIS WARRANTY: This limited warranty gives you specific legal rights, and you may also have other rights which vary from state to state.

Troy-Bilt LLC, P.O. BOX 361131 CLEVELAND, OHIO 44136-0019; Phone: 1-866-840-6483, 1-330-558-7220