

Bolens®

Operator's Manual

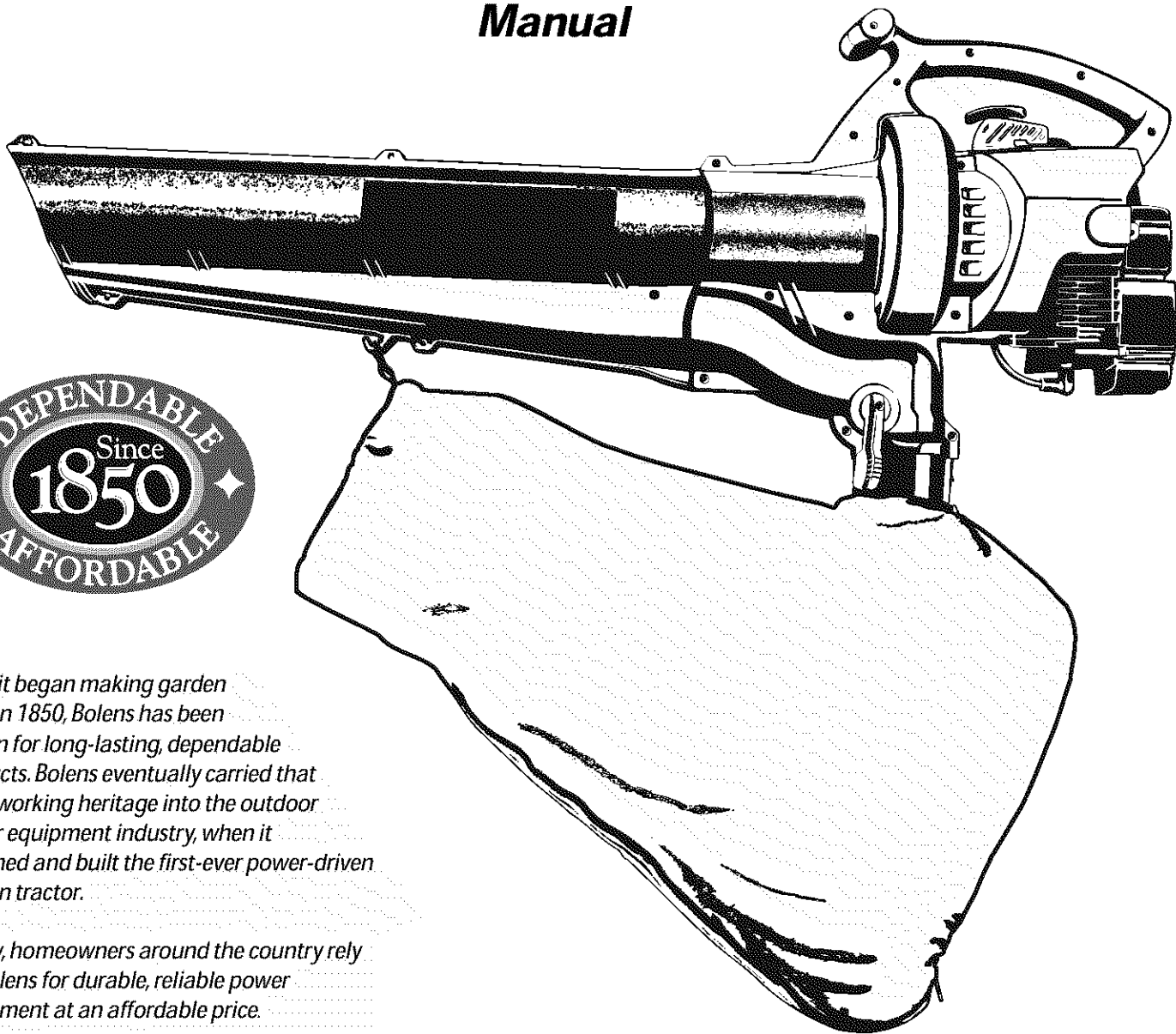

Since it began making garden tools in 1850, Bolens has been known for long-lasting, dependable products. Bolens eventually carried that hard-working heritage into the outdoor power equipment industry, when it designed and built the first-ever power-driven garden tractor.

Today, homeowners around the country rely on Bolens for durable, reliable power equipment at an affordable price.

**2-Cycle Petrol
Mulching Blower / Vacuum
Model BL3100**



INTRODUCTION

THANK YOU

Thank you for buying this quality product. This modern outdoor power tool will provide many hours of useful service. You will find it to be a great labor-saving device. This operator's manual provides you with easy-to-understand operating instructions. Read the whole manual and follow all the instructions to keep your new outdoor power tool in top operating condition.

PRODUCT REFERENCES, ILLUSTRATIONS AND SPECIFICATIONS

All information, illustrations and specifications in this manual are based on the latest product information available at the time of printing. We reserve the right to make changes at any time without notice.

Copyright © 2003 MTD SOUTHWEST INC
All Rights Reserved.

DO NOT RETURN THE UNIT TO THE RETAILER.

NOTE: PROOF OF PURCHASE WILL BE REQUIRED FOR WARRANTY SERVICE.

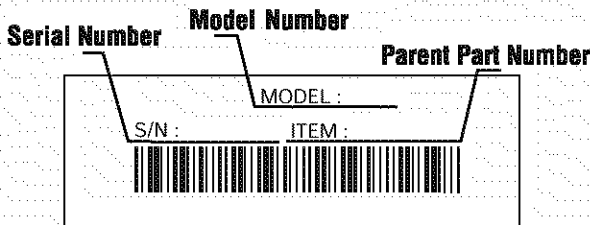

Copy the model / parent part number here: _____

Copy the serial number here: _____

TABLE OF CONTENTS

Service Information	2
Rules for Safe Operation	3
Know Your Unit	7
Assembly Instructions	8
Oil and Petrol Information	10
Starting/Stopping Instructions	11
Operating Instructions	12
Maintenance and Repair Instructions	15
Cleaning and Storage	18
Accessories and Replacement Parts	18
Troubleshooting Chart	19
Specifications	20
Warranty Information	24
Parts List	Inside Back Cover

CONTENTS OF CARTON

This unit includes the following:



- Model BL3100 Mulching Blower Vacuum
- Blower/Vacuum Tube
- Vacuum bag
- Shoulder Strap
- Patio Head
- Hardware Pack
- Bottle of 2-Cycle Oil
- Operator's Manual

Make sure you carefully read and understand this manual before starting or operating this equipment.

THIS PRODUCT IS COVERED BY ONE OR MORE US PATENTS, OTHER PATENTS PENDING.

Examine all parts to make certain that nothing is missing and no breakage has occurred during shipping. Any damaged or missing part must be replaced before using this product.

CALIFORNIA PROPOSITION 65 WARNING

	WARNING	
<p>THE ENGINE EXHAUST FROM THIS PRODUCT CONTAINS CHEMICALS KNOWN TO THE STATE OF CALIFORNIA TO CAUSE CANCER, BIRTH DEFECTS OR OTHER REPRODUCTIVE HARM.</p>		

SPARK ARRESTOR

NOTE: For users on U.S. Forest Land and in the states of California, Maine, Oregon and Washington. All U.S. Forest Land and the state of California (Public Resources Codes 4442 and 4443), Oregon and Washington require, by law that certain internal combustion engines operated on forest brush and/or grass-covered areas be equipped with a spark arrestor, maintained in effective working order, or the engine be constructed, equipped and maintained for the prevention of fire. Check with your state or local authorities for regulations pertaining to these requirements. Failure to follow these requirements could subject you to liability or a fine. **This unit is factory equipped with a spark arrestor.** If it requires replacement, ask your LOCAL SERVICE DEALER to install the **Accessory Part #182747 Spark Arrestor Kit.**

WARNING!

Read the Operator's Manual(s) and follow all warnings and safety instructions. Failure to do so can result in serious injury to the operator and/or bystanders.

RULES FOR SAFE OPERATION

The purpose of safety symbols is to attract your attention to possible dangers. The safety symbols, and their explanations, deserve your careful attention and understanding. The safety warnings do not by themselves eliminate any danger. The instructions or warnings they give are not substitutes for proper accident prevention measures.

NOTE: Advises you of information or instructions vital to the operation or maintenance of the equipment.

SYMBOL	MEANING
---------------	----------------

SYMBOL	MEANING
---------------	----------------



DANGER: Failure to obey a safety warning will result in serious injury to yourself or to others. Always follow the safety precautions to reduce the risk of fire, electric shock and personal injury.



WARNING: Failure to obey a safety warning can result in injury to yourself and others. Always follow the safety precautions to reduce the risk of fire, electric shock and personal injury.



CAUTION: Failure to obey a safety warning may result in property damage or personal injury to yourself or to others. Always follow the safety precautions to reduce the risk of fire, electric shock and personal injury.



SAFETY ALERT SYMBOL: Indicates danger, warning or caution. Attention is required in order to avoid serious personal injury. May be used in conjunction with other symbols or pictographs.

RULES FOR SAFE OPERATION

• IMPORTANT SAFETY INFORMATION •

READ ALL INSTRUCTIONS BEFORE OPERATING



WARNING: When using the unit, you must follow the safety rules. For your own safety and that of bystanders, please read these instructions before operating the unit. Please keep the instructions for later use.

- Read the instructions carefully. Be familiar with the controls and proper use of the unit.
- Do not operate this unit when tired, ill, or under the influence of alcohol, drugs, or medication.
- Children and teens under the age of 15 must not use the unit, except for teens guided by an adult.
- All guards and safety attachments must be installed properly before operating the unit.
- Inspect the unit before use. Replace damaged parts. Check for petrol leaks. Make sure all fasteners are in place and secure. Replace parts that are cracked, chipped, or damaged in any way. Do not operate the unit with loose or damaged parts.
- Carefully inspect the area before starting the unit. Remove all debris and hard or sharp objects such as glass, wire, etc.
- Clear the area of children, bystanders, and pets. At a minimum, keep all children, bystanders, and pets outside a 15 m (50 feet) radius; there still may be a risk to bystanders from thrown objects. Bystanders should be encouraged to wear eye protection. If you are approached, stop the unit immediately.

SAFETY WARNINGS FOR PETROL UNITS



WARNING: Petrol is highly flammable, and its vapors can explode if ignited. Take the following precautions:

- Store petrol only in containers specifically designed and approved for the storage of such materials.
- Avoid creating a source of ignition for spilled petrol. Do not start the engine until petrol vapors dissipate.
- Always stop the engine and allow it to cool before filling the petrol tank. Never remove the cap of the petrol tank, or add petrol, when the engine is hot. Never operate the unit without the petrol cap securely in place. Loosen the petrol tank cap slowly to relieve any pressure in the tank.
- Mix and add petrol in a clean, well-ventilated outdoor area where there are no sparks or flames. Slowly remove the petrol cap only after stopping engine. Do not smoke while fueling or mixing petrol. Wipe up any spilled petrol from the unit immediately. Always wipe unit dry before using.
- Move the unit at least 9.1 m (30 feet) from the fueling source and site before starting the engine. Do not smoke or allow sparks and open flames near the area while adding petrol or operating the unit.

WHILE OPERATING

- Never start or run the unit inside a closed room or building. Breathing exhaust fumes can kill. Operate this unit only in a well-ventilated outdoor area.
- To reduce the risk of injury associated with thrown objects, wear safety glasses or goggles that are marked as meeting ANSI Z87. standards.
- Never run the unit without the the proper equipment attached. When using this unit, always install the blower/vacuum tubes and vacuum bag depending on model. Make sure the vacuum bag is completely zipped closed.
- To reduce the risk of hearing loss associated with sound level(s), always wear ear/hearing protection when operating this unit.
- Wear heavy, long pants, boots, and gloves. Do not wear short pants, sandals, or go barefoot.
- To avoid static electricity shock, do not wear rubber gloves or any other insulated gloves while operating this unit.
- To reduce the risk of injury associated with objects being drawn into rotating parts, do not wear loose clothing, jewelry, scarves, and the like. Secure hair above shoulder level.
- Wear a face or dust mask if the operation is dusty. Long sleeve shirts are recommended.
- Use the unit only in daylight or good artificial light.
- Keep outside surfaces free from oil and petrol.
- Avoid accidental starting. Be in the starting position whenever pulling the starter rope. The operator and unit must be in a stable position while starting. Refer to *Starting/Stopping Instructions*.
- Do not set unit on any surface except a clean, hard area while engine is running. Debris such as gravel, sand, dust, grass, etc. could be picked up by the air intake and thrown out by the discharge opening, damaging unit, property, or causing serious injury to bystanders or operator.
- Use the right tool. Only use this tool for the purpose intended.
- Do not force unit. It will do the job better and with less likelihood of injury at a rate for which it was designed.
- Do not overreach or use from unstable surfaces such as ladders, trees, steep slopes, rooftops, etc. Always keep proper footing and balance.
- Always hold the unit with a firm grip when operating.
- Keep hands, face, and feet at a distance from all moving parts. Do not touch or try to stop the impeller when it is rotating. Do not operate without guards in place.
- Do not put any object into openings. Do not use with any opening blocked; keep free of dirt, debris, and anything that may reduce the air flow.

RULES FOR SAFE OPERATION

- Do not touch the engine or muffler. These parts get extremely hot from operation. When turned off they remain hot for a short time.
- Do not operate the engine faster than the speed needed to do the job. Do not run the engine at high speed when not in use.
- Always stop the engine when operation is delayed or when walking from one location to another.
- Stop the engine for maintenance, repair, to install or remove the blower tubes or vacuum attachments. The unit must be stopped and the impeller no longer turning to avoid contact with the rotating blades.
- Use only original equipment manufacturer replacement parts when servicing this unit. These parts are available from your authorized service dealer. Do not use unauthorized parts, accessories, or attachments for this unit. Doing so could lead to serious injury to the user, or damage to the unit, and void your warranty.
- Never use this unit for spreading chemicals, fertilizers or other substances which may contain toxic materials.
- To reduce fire hazard, replace faulty muffler and spark arrestor, keep the engine and muffler free from grass, leaves, excessive grease or carbon build up.

WHILE OPERATING UNIT AS A BLOWER

- Never point the blower in the direction of people or pets, or in the direction of windows. Always direct the blowing debris away from people, animals, and windows. Use extra caution when blowing debris near solid objects such as trees, automobiles, walls, etc.

WHILE OPERATING UNIT AS A VACUUM

- Avoid situations that could catch the vacuum bag on fire. Do not operate near an open flame. Do not vacuum warm ash from fireplaces, barbecue pits, brush piles, etc. Do not vacuum discarded cigars or cigarettes unless the cinders are completely cool.

- The unit is designed to pickup dry material such as leaves, grass, small twigs, and bits of paper. Do not attempt to vacuum wet debris and/or standing water as this may result in damage to the blower/ vacuum. To avoid severe damage to the impeller, do not vacuum metal, broken glass, etc.

OTHER SAFETY WARNINGS

- Always disconnect the spark plug before performing maintenance or accessing movable parts.
- Never store the unit, with petrol in the tank, inside a building where fumes may reach an open flame (pilot lights, etc.) or sparks (switches, electrical motors, etc.).
- Allow the engine to cool before storing or transporting. Be sure to secure the unit while transporting.
- Store the unit in a dry place, either locked up or up high to prevent unauthorized use or damage. Keep out of the reach of children.
- Never douse or squirt the unit with water or any other liquid. Keep handles dry, clean, and free from debris. Clean after each use, see *Cleaning and Storage* instructions.
- Keep these instructions. Refer to them often and use them to instruct other users. If you loan this unit to others, also loan these instructions to them.

SPECIAL NOTE: Exposure to vibrations through prolonged use of petrol powered hand tools could cause blood vessel or nerve damage in the fingers, hands, and joints of people prone to circulation disorders or abnormal swelling. Prolonged use in cold weather has been linked to blood vessel damage in otherwise healthy people. If symptoms occur such as numbness, pain, loss of strength, change in skin color or texture, or loss of feeling in the fingers, hands or joints, discontinue use of this tool and seek medical attention. An anti-vibration system does not guarantee avoidance of these problems. Users who operate power tools on a regular basis must closely monitor their physical condition and the condition of this tool.

SAVE THESE INSTRUCTIONS

RULES FOR SAFE OPERATION

SAFETY AND INTERNATIONAL SYMBOLS

This operator's manual describes safety and international symbols and pictographs that may appear on this product. Read the operator's manual for complete safety, assembly, operating and maintenance and repair information.

SYMBOL

MEANING



• SAFETY ALERT SYMBOL

Indicates danger, warning, or caution. May be used in conjunction with other symbols or pictographs.



• WARNING - READ OPERATOR'S MANUAL

Read the Operator's Manual(s) and follow all warnings and safety instructions. Failure to do so can result in serious injury to the operator and/or bystanders.



• WEAR EYE AND HEARING PROTECTION

WARNING: Thrown objects and loud noise can cause severe eye injury and hearing loss. Wear eye protection meeting ANSI Z87.1-1989 standards and ear protection when operating this unit. Use a full face shield when needed.



• KEEP BYSTANDERS AWAY

WARNING: Keep all bystanders, especially children and pets, at least 15 m (50 feet) from the operating area.



• UNLEADED PETROL

Always use clean, fresh unleaded petrol.



• OIL

Refer to operator's manual for the proper type of oil.



• THROWN OBJECTS AND ROTATING CUTTER CAN CAUSE SEVERE INJURY

WARNING: Keep clear of blower outlet. Never point the blower at yourself or others. Objects can be thrown from blower. Do not operate unit without proper attachments and guards in place.

SYMBOL

MEANING



• ON/OFF STOP CONTROL

ON / START / RUN



• ON/OFF STOP CONTROL

OFF or STOP



• HOT SURFACE WARNING

Do not touch a hot muffler or cylinder. You may get burned. These parts get extremely hot from operation. When turned off they remain hot for a short time.



• CHOKE CONTROL

A • **FULL** choke position.
B • **PARTIAL** choke position.
C • **RUN** position.



• BLOWERS - ROTATING IMPELLER BLADES CAN CAUSE SEVERE INJURY

WARNING: Stop the engine and allow the impeller to stop before opening the vacuum door, installing or changing tubes or bag, or before cleaning or performing any maintenance.



• BLOWER/VACUUM MODE CHANGE-OVER LEVER

A - Vacuum mode
B - Blower mode



• THROTTLE CONTROL

Indicates "HIGH" or "FASTEST" speed.



• THROTTLE CONTROL

Indicates "IDLE", "LOW" or "SLOWEST" speed.

RULES FOR SAFE OPERATION

KNOW YOUR UNIT

APPLICATION

As a blower:

- Cleaning yards, garages, driveways, porches, patios, around walls, fences and more

As a vacuum:

- Picking up leaves and other light debris

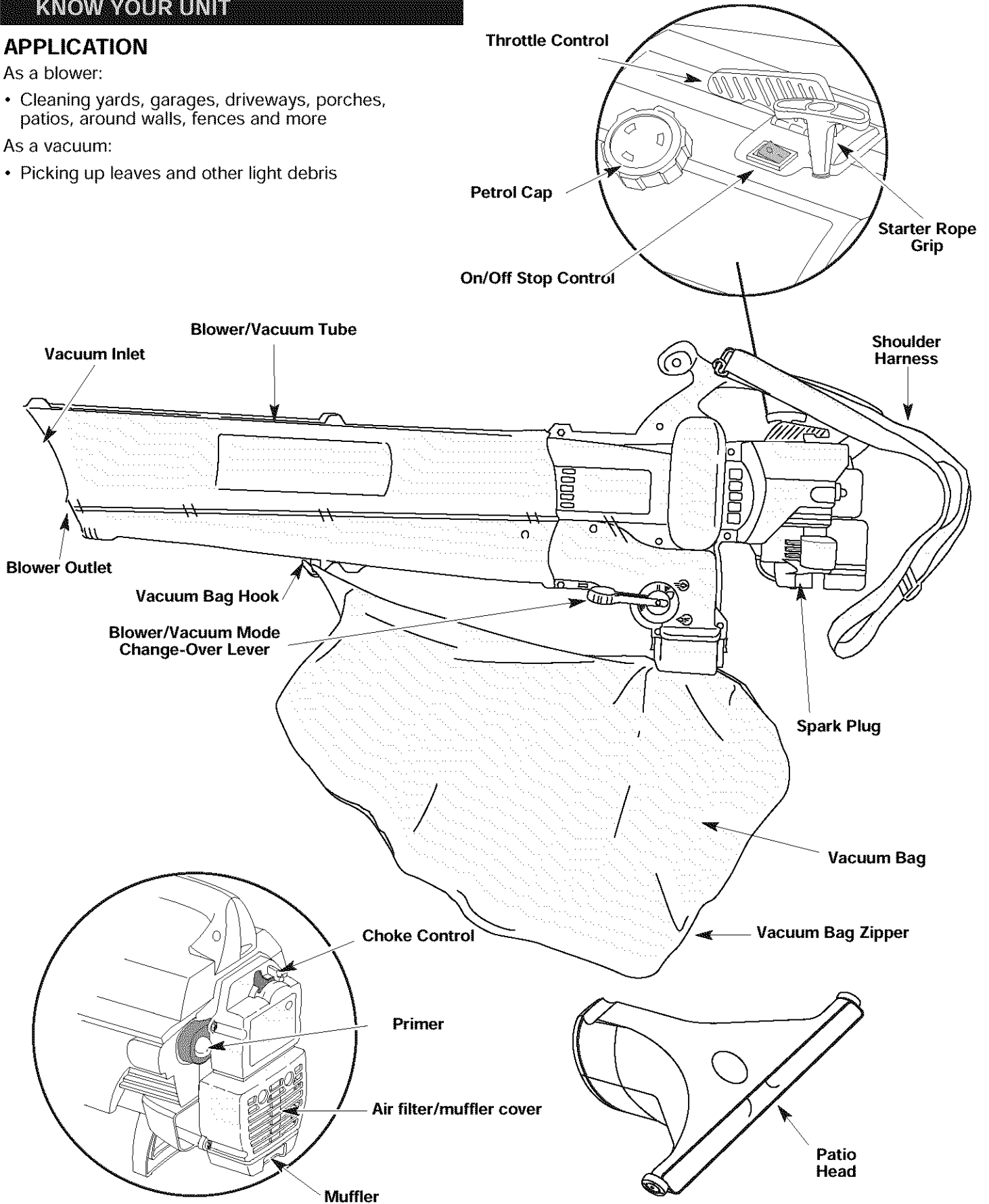

ASSEMBLY INSTRUCTIONS

ATTACHING AND REMOVING THE BLOWER/VACUUM TUBE



WARNING: To avoid serious personal injury, the blower/vacuum tube and vacuum bag must be used when operating this unit.

Attaching

NOTE: The Blower/Vacuum Tube comes unassembled on this unit. Installation is required to provide safe and easy use for the operator.



WARNING: To prevent serious personal injury, stop the engine and allow the impeller to stop before attaching or removing tubes.

1. Remove the screws and nuts provided from the hardware pack.
2. Insert the blower/vacuum tube all the way into the opening on the motor housing until the holes in the tabs on the blower/vacuum tube align with the screw holes in the housing (Fig. 1).
3. Insert the 2 (two) 8-32 x 3/4" slotted T20 Torx screws into the right side of the motor housing and the 2 (two) nuts into the left side of the motor housing (Fig. 1).

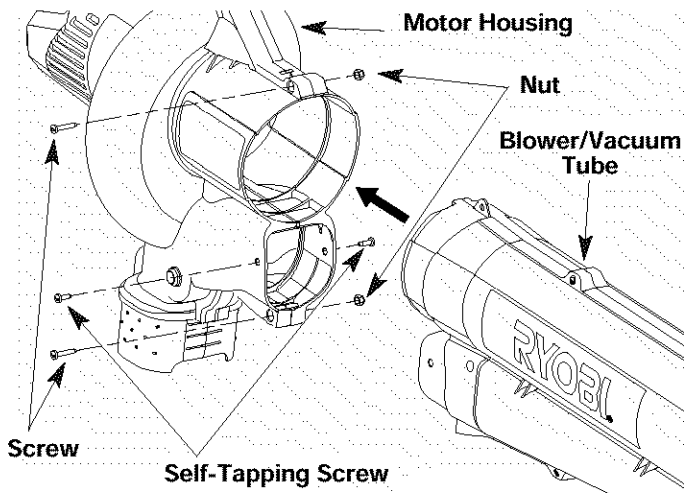

Fig. 1

4. Tighten the screws firmly. Do not over-tighten.
5. Install the 2 (two) remaining self-tapping 8-16 x 3/4" slotted T20 Torx screws into the holes on either side of the housing (Fig. 1). Tighten until snug, do not over-tighten.

Removing

NOTE: It may be necessary to remove the Blower/Vacuum Tube to clear a blocked tube or impeller.



WARNING: To prevent serious personal injury, stop the engine and allow the impeller to stop before attaching or removing tubes.

1. Remove the 2 (two) self-tapping screws from either side of the housing.
2. Remove the 2 (two) screws and nuts holding the blower/vacuum tube on the housing (Fig. 2).

NOTE: Keep the hardware in a safe place for future use.

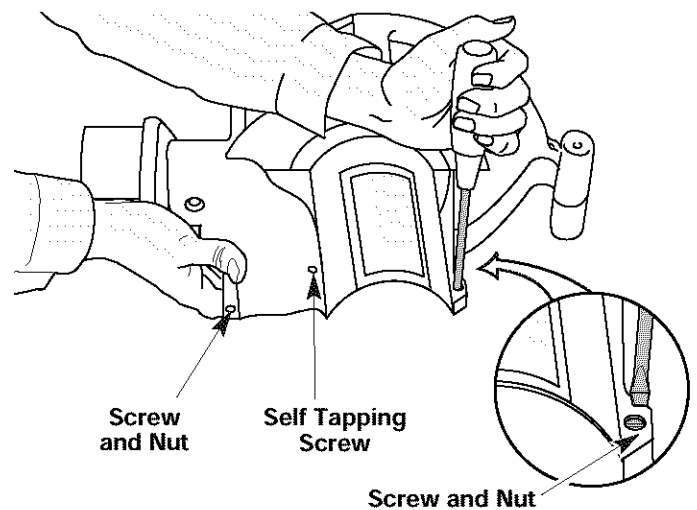

Fig. 2

3. Remove the blower/vacuum tube from the motor housing.
4. Replace Blower/Vacuum Tube before use.

ASSEMBLY INSTRUCTIONS

ATTACHING AND REMOVING THE VACUUM BAG

Attaching

1. Attach the vacuum bag to the vacuum bag hook on the blower/vacuum tube (Fig. 3).

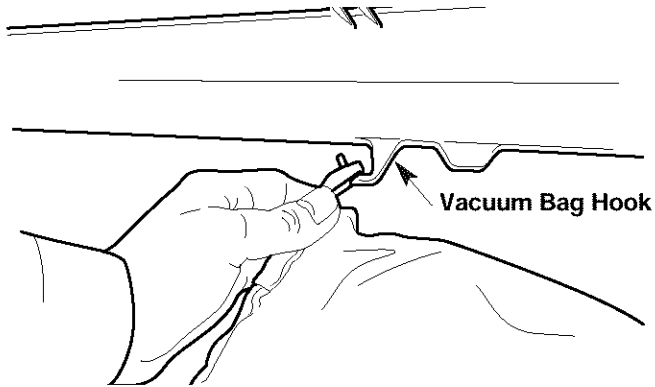

Fig. 3

2. Slide the vacuum bag tube over the debris exhaust tube on the housing. Push the tube until the latching tabs on both sides click into place, securing the bag on the unit (Fig. 4).

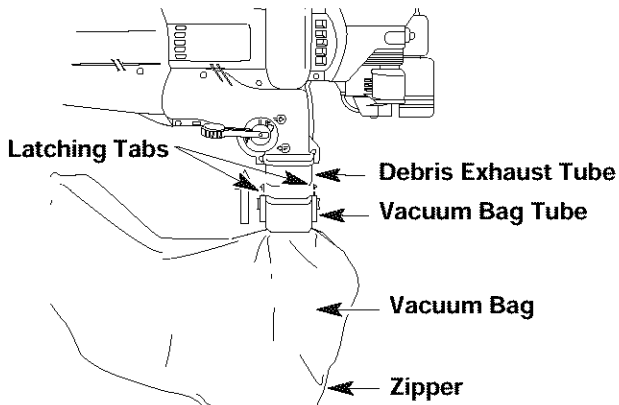

Fig. 4

Removing

1. Press the latching tabs on both sides of the vacuum bag tube and pull the vacuum bag down from the unit (Fig. 5).
2. Detach the vacuum bag from the vacuum bag hook.

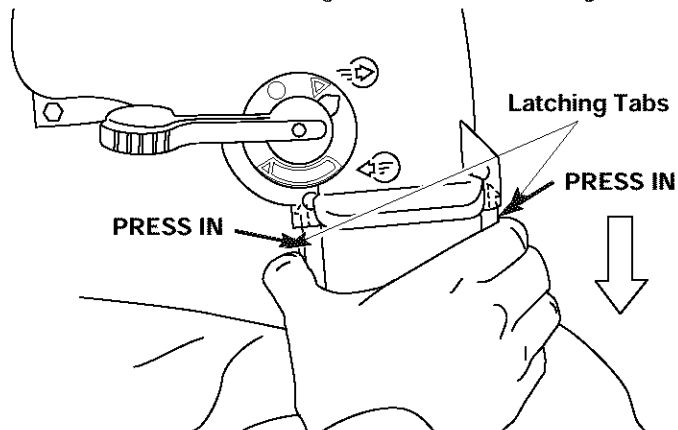

Fig. 5

INSTALLING THE SHOULDER HARNESS



WARNING: To avoid serious personal injury, never attempt to start the unit when standing, when the unit is clipped to the shoulder strap. Always follow the starting procedures as described in the *Starting/Stopping Instructions* section.

1. Push the strap through the center of the buckle.
2. Pull the strap over the cross bar and down through the slot in the buckle (Fig. 6).

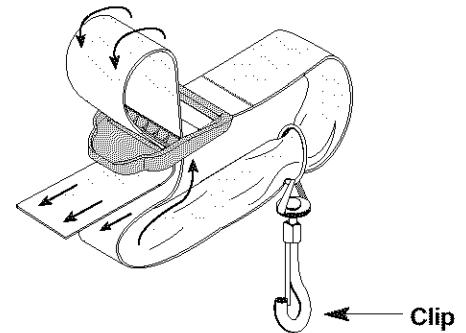

Fig. 6

3. Snap the clip on to the support fitting (Fig. 7).

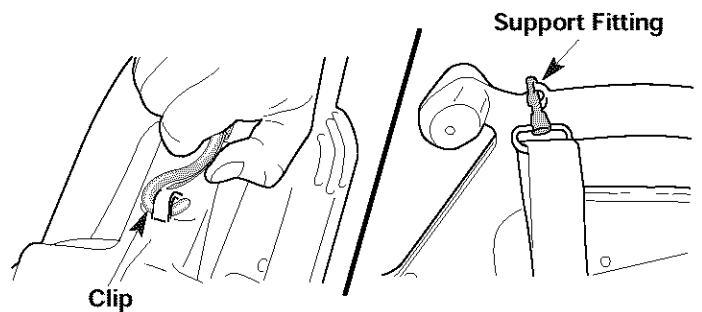

Fig. 7

4. While standing in the operating position adjust length to fit the operator's size. Pull tab to lengthen, pull strap to shorten (Fig. 8).

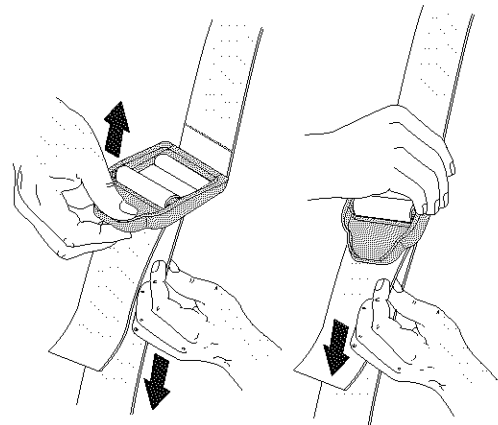

Fig. 8

OIL AND PETROL INFORMATION

OIL AND PETROL MIXING INSTRUCTIONS

Old and/or improperly mixed petrol are the main reasons for the unit not running properly. Be sure to use fresh, clean unleaded petrol. Follow the instructions carefully for the proper petrol/oil mixture.

Definition of Blended Petrols

Today's petrols are often a blend of petrol and oxygenates such as ethanol, methanol, or MTBE (ether). Alcohol-blended petrol absorbs water. As little as 1% water in the petrol can make petrol and oil separate. It forms acids when stored. When using alcohol-blended petrol, use fresh petrol (less than 60 days old).

Using Blended Petrols

If you choose to use a blended petrol, or its use is unavoidable, follow recommended precautions:

- Always use the fresh petrol mix explained in your operator's manual
- Always agitate the petrol mix before fueling the unit
- Drain the tank and run the engine dry before storing the unit

Using Petrol Additives



The bottle of 2-cycle oil that came with your unit contains a petrol additive which will help inhibit corrosion and minimize the formation of gum deposits. It is recommended that you use our 2-cycle oil with this unit.

If unavailable, use a good 2-cycle oil designed for air-cooled engines along with a petrol additive, such as STA-BIL® Petrol Stabilizer or an equivalent. Add 23 ml (0.8 oz) of petrol additive per gallon of petrol according to the instructions on the container. NEVER add petrol additives directly to the unit's petrol tank.

	CAUTION: For proper engine operation and maximum reliability, pay strict attention to the oil and petrol mixing instructions on the 2-cycle oil container. Using improperly mixed petrol can severely damage the engine.
---	---

Thoroughly mix the proper ratio of 2-cycle engine oil with unleaded petrol in a separate petrol can. Use a 40:1 petrol/oil ratio. Do not mix them directly in the engine petrol tank. See the table below for specific petrol and oil mixing ratios.

NOTE: 3.8 liters (1 US gallon) of unleaded petrol mixed with one 95 ml (3.2 oz) bottle of 2-cycle oil makes a 40:1 petrol/oil ratio.

	+	
UNLEADED PETROL		2 CYCLE OIL
3.8 LITERS (1 GALLON US)		95 ml (3.2 FL. OZ)
1 LITER		25 ml

MIXING RATIO - 40:1

	WARNING: Petrol is extremely flammable. Ignited Vapors may explode. Always stop the engine and allow it to cool before filling the petrol tank. Do not smoke while filling the tank. Keep sparks and open flames at a distance from the area.
--	--

	WARNING: Remove petrol cap slowly to avoid injury from petrol spray. Never operate the unit without the petrol cap securely in place.
---	--

	WARNING: Add petrol in a clean, well ventilated outdoor area. Wipe up any spilled petrol immediately. Avoid creating a source of ignition for spilt petrol. Do not start the engine until petrol vapors dissipate.
---	---

NOTE: Dispose of the old petrol/oil mix in accordance to Federal, State and Local regulations.

STARTING/STOPPING INSTRUCTIONS

STARTING INSTRUCTIONS



WARNING: Operate this unit only in a well-ventilated outdoor area. Carbon monoxide exhaust fumes can be lethal in a confined area.



WARNING: Avoid accidental starting. Make sure you are in the starting position when pulling the starter rope (Fig. 11). To avoid serious injury, the operator and unit must be in a stable position while starting.

Do not set unit on any surface except a clean, hard area while starting. Debris such as gravel, sand, dust and grass could be picked up by the air intake and thrown out by the discharge opening. This could damage the unit, property, or cause serious injury to bystanders or operator.

1. Mix petrol with oil. Fill petrol tank with petrol/oil mixture. Refer to *Oil and Petrol Mixing Instructions*.



WARNING: To avoid serious personal injury, always remove the vacuum bag prior to refueling the unit. The bag may become a fire hazard when saturated with petrol.

NOTE: The throttle control will remain in the position it's placed until moved by the operator. Fast position is to the right.

2. Set the blower/vacuum mode change-over lever to the up position (Blower Mode). See *Operating as a Blower*. This prevents the vacuum bag from filling up while starting the engine.
3. Fully press and release the primer bulb 10 times, slowly, until **PETROL IS VISIBLE IN THE PRIMER BULB** (Fig. 10). If you can't see petrol in the bulb, press and release the bulb as many times as it takes before you can see petrol in it.
4. Place the choke lever in Position **A** (Fig. 10).
5. Place the unit in the starting position (Fig. 11). Move the throttle control to the fast position (👉) (Fig. 9).
6. Pull the starter rope briskly 5 times.
7. Place the choke lever in Position **B**.
8. Pull starter rope briskly 1 to 3 times to start the engine (Fig. 11).
9. If the engine does not start, repeat steps 3 through 8.

NOTE: If the engine floods while trying to start, place the choke lever in Position **C**. Move the throttle control to the fast position (👉). Pull the starter rope briskly. The engine should start with three (3) to eight (8) pulls.

10. Allow the engine to warm up for 5 to 10 seconds. Place the choke lever in Position **C**.

NOTE: Choking is unnecessary when starting a warm engine. Put the throttle control in the fast position (👉) (Fig 9) and start unit with the choke control in Position **B**.

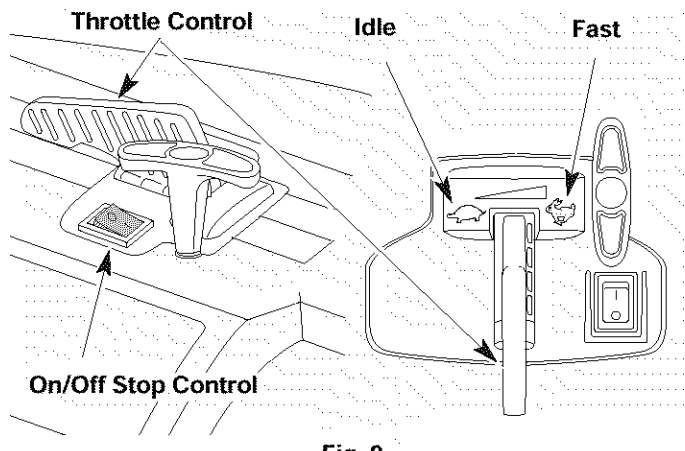

Fig. 9

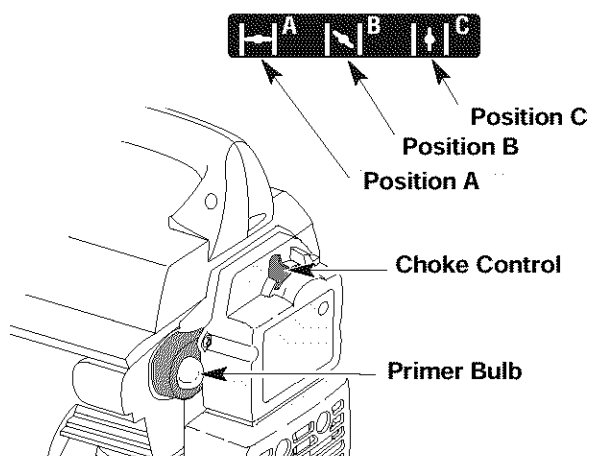

Fig. 10

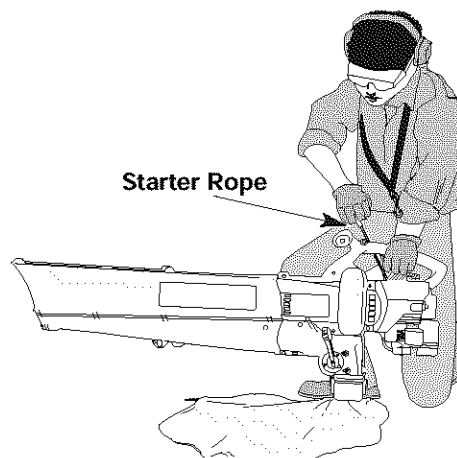

Fig. 11

STOPPING INSTRUCTIONS

1. Move the throttle control to the idle position (👈). Allow the engine to cool down by idling for 10-15 seconds.
2. Press the On/Off Stop control down in the **STOP (O)** position until the engine comes to a complete stop.

OPERATING INSTRUCTIONS

HOLDING THE BLOWER/VACUUM

Before operating the unit, stand in the operating position. (Fig. 12). Check for the following:

- Operator is wearing proper clothing, such as boots, safety glasses or goggles, ear/hearing protection, gloves, long pants and long sleeve shirt

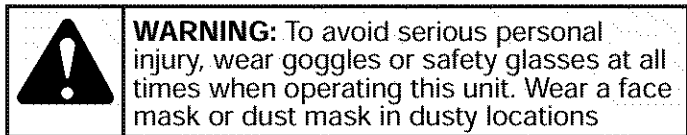

- If the conditions are dusty, the operator is wearing a dust mask or face mask
- The unit is in good working condition
- The tubes and guards are in place and secure

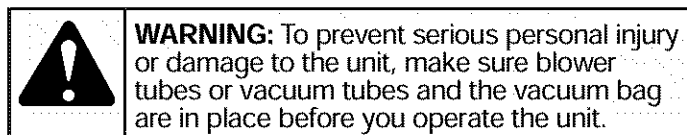

OPERATING TIPS

- Be sure the vacuum bag is zipped closed before operating the unit.
- Assure the unit is not directed at anybody or any loose debris before starting the unit.
- Verify that the unit is in good working condition. Make sure the tubes and guards are in place and secure.
- Always hold the unit with both hands when operating. Keep a firm grip on both the front and rear handle or grips.
- To reduce the risk of hearing loss associated with sound level(s), hearing protection is required.
- Operate power equipment only at reasonable hours—not early in the morning or late at night when people might be disturbed. Comply with times listed in local ordinances. Usual recommendations are 9:00 am to 5:00 pm, Monday through Saturday.
- To reduce noise levels, limit the number of pieces of equipment used at any one time.



Fig. 12

- To reduce noise levels, operate power blowers at the lowest possible speed to do the job.
- Check your equipment before operation, especially the muffler, air intakes and air filters.
- Use rakes and brooms to loosen debris before blowing.
- In dusty conditions, slightly dampen surfaces or use a mister attachment when water is available.
- Conserve water by using power blowers instead of hoses for many lawn and garden applications, including areas such as gutters, screens, patios, grills, porches, and gardens.
- Watch out for children, pets, open windows or freshly washed cars, and blow debris safely away.
- Use the full blower nozzle extension so the air stream can work close to the ground.
- Clean up after using blowers and other equipment. Dispose of debris appropriately.

OPERATING AS A BLOWER

Converting to a Blower

1. Start engine. See *Starting/Stopping Instructions*.
2. Set the blower/vacuum mode change-over lever to the up position (Blower Mode) (Fig. 13).

NOTE: Never use the unit with the lever in a position half way between either mode.

3. Place the shoulder harness over your head and onto your shoulder and adjust it. Refer to *Installing the Shoulder Harness*.

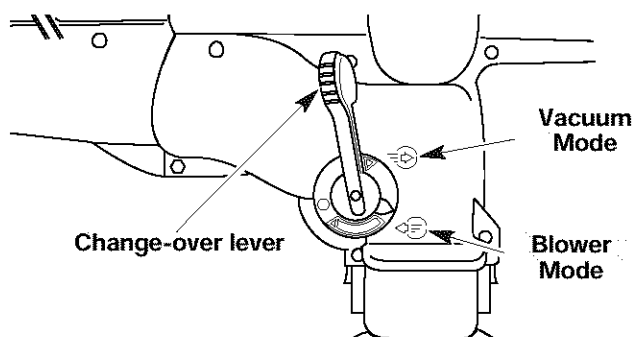

Fig. 13

Blower Operating Procedures

Hold the blower as shown in Figures 14, 15, and 16. Sweep from side to side with the nozzle several inches above the ground or floor. Slowly advance the unit, keeping the accumulated pile of debris in front of you.

Most dry blowing operations are better suited to low speeds, rather than high. High speed blowing is a better way to move heavier items like large debris or gravel.

1. Use the blower for trees, shrubs, flower beds and hard-to-clean areas (Fig. 14).
2. Use the unit around buildings and for other normal cleaning procedures (Fig. 15).
3. Use the blower around walls, overhangs, fences and screens (Fig. 16).

OPERATING INSTRUCTIONS



Fig. 14

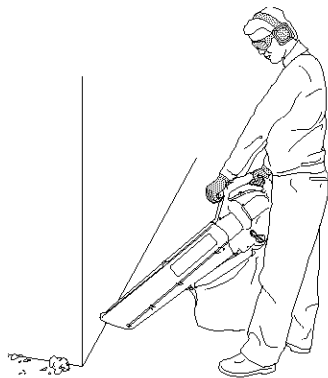

Fig. 15

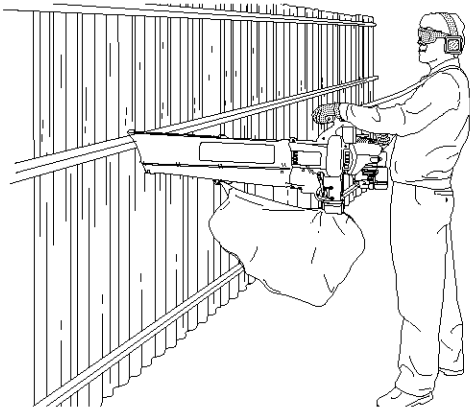

Fig. 16

Vacuum Operation Procedures

Check for the following before operating the unit:

- Operator is wearing proper clothing, such as boots, safety glasses or goggles, ear/hearing protection, gloves, long pants and long sleeve shirt
- If the conditions are dusty, operator is equipped with a dust mask or face mask
- The unit is in good working condition-- the vacuum tubes and vacuum bag are in place and secure.
- The vacuum bag harness is in place and adjusted

Use the unit for vacuuming up light debris like leaves and paper. Hold the vacuum, tilting the suction tube slightly (50-100 mm or 2-4 inches), and use a sweeping action to collect light debris (Fig. 18). The debris will flow into the vacuum bag. Items such as small leaves and small twigs will be mulched as they pass through the fan housing, allowing the vacuum bag to hold more debris.

When the bag is full, suction will noticeably decrease. Turn off the unit and allow the impeller to stop before you unzip the bag. Unzip the bag and empty the contents before continuing. Refer to *Emptying the Vacuum Bag*.



Fig. 18

OPERATING AS A VACUUM

Converting to Vacuum

1. Start engine. See *Starting/Stopping Instructions*.
2. Set the blower/vacuum mode change-over lever to the down position (Vacuum Mode) (Fig. 17).

NOTE: Never use the unit with the lever in a position half way between either mode.

3. Place the shoulder harness over your head, onto your shoulder and adjust it if necessary. Refer to *Installing the Shoulder Harness*.

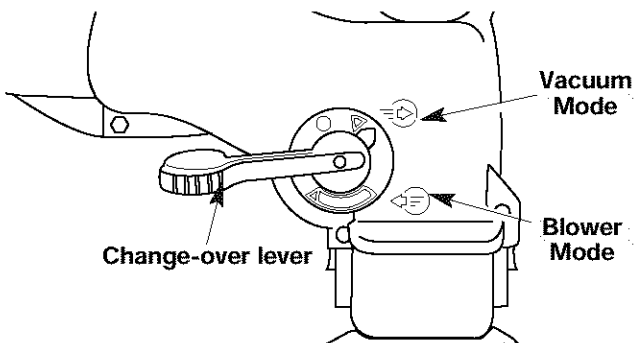

Fig. 17

WARNING: To avoid serious personal injury, never unzip the vacuum bag without stopping the unit first

WARNING: As a vacuum, the unit is designed to pick up dry material such as leaves, grass, small twigs and bits of paper. To avoid serious personal injury, do not attempt to vacuum wet debris and/or standing water as this may result in damage to the blower/ vacuum. To avoid severe damage to the impeller, do not vacuum metal, broken glass or similar items.

WARNING: Avoid situations that could catch the vacuum bag on fire. Do not operate near an open flame. Do not vacuum warm ash from fireplaces, barbecue pits, brush piles, etc. Do not vacuum discarded cigars or cigarettes unless the cinders are completely cool.

WARNING: To prevent serious personal injury or damage to the unit, always install vacuum tubes, the vacuum bag and make sure the vacuum bag is completely zipped closed when operating this unit as a vacuum.

MAINTENANCE AND REPAIR INSTRUCTIONS

MAINTENANCE SCHEDULE

Perform these required maintenance procedures at the frequency stated in the table. These procedures should also be a part of any seasonal tune-up.

NOTE: Some maintenance procedures may require special tools or skills. If you are unsure about these procedures take your unit to any non-road engine repair establishment, individual or authorized service dealer.



WARNING: To prevent serious injury, never perform maintenance or repairs with unit running. Always service and repair a cool unit. Disconnect the spark plug wire to ensure that the unit cannot start.

NOTE: Maintenance, replacement, or repair of the emission control devices and system may be performed by any non-road engine repair establishment, individual or authorized service dealer.

In order to assure peak performance of your engine, inspection of the engine exhaust port may be necessary after 50 hours of operation. If you notice lost RPM, poor performance or general lack of acceleration, this service may be required. If you feel your engine is in need of this inspection, refer service to any non-road engine repair establishment, individual or authorized service dealer for repair. **DO NOT** attempt to perform this process yourself as engine damage may result from contaminants involved in the cleaning process for the port.

FREQUENCY	MAINTENANCE REQUIRED	REFER TO
Before starting engine	Fill petrol tank with fresh petrol	Page 10
Every 10 hours	Clean and re-oil air filter	Page 15
Every 25 hours	Check and clean spark arrestor Check spark plug condition and gap	Page 16 Page 17
Every 50 hours	Inspect exhaust port and spark arrestor screen for clogging or obstruction to assure maximum performance levels	Page 16

AIR FILTER MAINTENANCE

Removing the Air Filter/Muffler Cover



WARNING: To avoid serious personal injury, always turn your unit off and allow it to cool before you clean or service it.

- Place the choke lever in the **PARTIAL** choke position (B).

NOTE: The choke lever must be in the **PARTIAL** choke position (B) to remove the air filter/ muffler cover.

- Remove the four (4) screws securing the air filter/muffler cover (Fig. 22). Use a flat blade or T-20 Torx bit screwdriver.
- Pull the cover from the engine. Do not force.

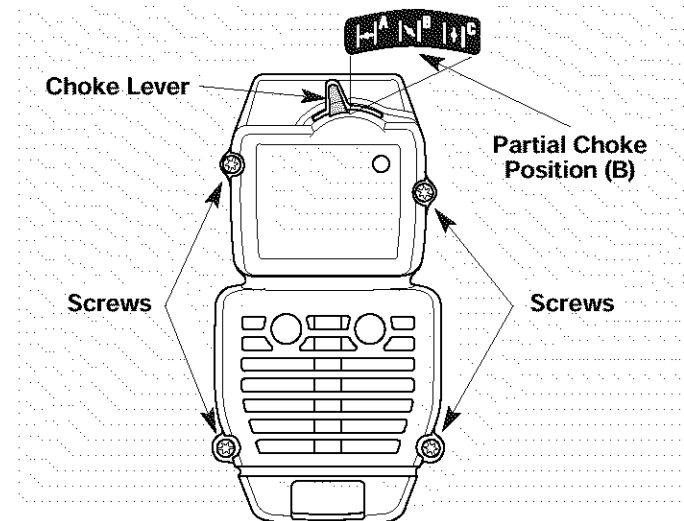

Fig. 22

Cleaning the Air Filter

Clean and re-oil the air filter every 10 hours of operation. It is an important item to maintain. Failure to maintain the air filter will VOID the warranty.

- Remove air filter/muffler cover. Refer to *Removing the Air Filter/Muffler Cover*.
- Turn cover over and look inside to locate the air filter. Remove the air filter from inside the air filter/muffler cover (Fig. 23).
- Wash the filter in detergent and water (Fig. 24). Rinse the filter thoroughly. Squeeze out excess water. Allow it to dry completely.

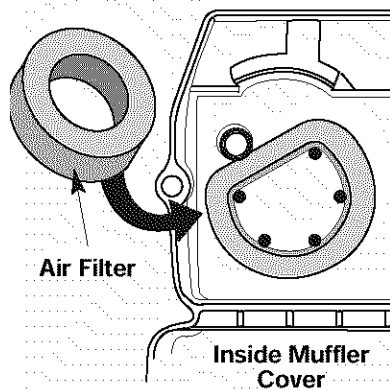

Fig. 23

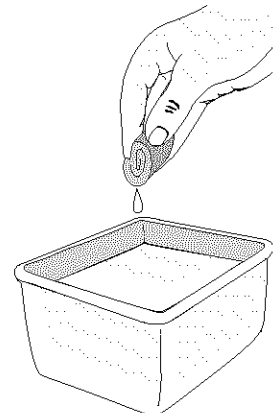

Fig. 24

MAINTENANCE AND REPAIR INSTRUCTIONS

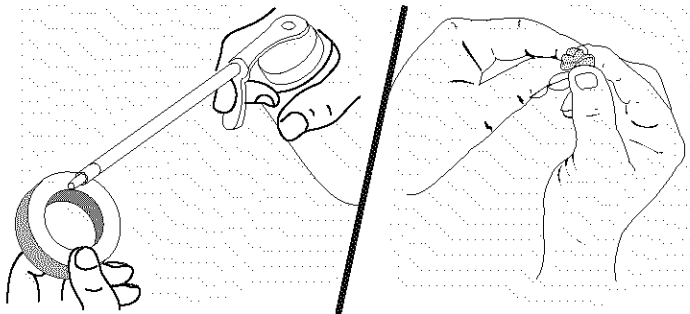

Fig. 25

Fig. 26

4. Apply enough clean SAE 30 oil to lightly coat the filter (Fig. 25).
5. Squeeze the filter to spread and remove excess oil (Fig. 26).
6. Replace the air filter inside the air filter/muffler cover (Fig. 23).

NOTE: Operating the unit without the air filter and air filter/muffler cover assembly will VOID the warranty.

Reinstalling the Air Filter/Muffler Cover

1. Place the air filter/muffler cover over the back of the carburetor and muffler. Align the screw holes.
2. Insert the four (4) screws into the holes in the air filter/muffler cover (Fig. 22) and tighten.
Do not over tighten.

SPARK ARRESTOR MAINTENANCE

1. Remove air filter/muffler cover. Refer to *Removing the Air Filter/Muffler Cover*.
2. Locate muffler front and the two (2) bolts securing it to the engine (Fig. 27). Remove the two (2) bolts using a Torx screwdriver or 5/16-inch socket or nut driver. Pull muffler off of the engine.
3. Turn muffler over to the back side and locate the exhaust gasket. Remove the muffler gasket from the muffler (Fig. 27).

NOTE: If the exhaust gasket is torn or damaged, replace it with a new gasket before reassembling muffler.

4. Using a small flatblade screwdriver, carefully pry up the spark arrestor from the recessed hole (Fig. 28). Remove the spark arrestor from the muffler.
5. Clean the spark arrestor with a wire brush. Replace it if it is damaged or if it is impossible to clean thoroughly (Fig. 28).
6. Reinstall the spark arrestor by pressing it into the recessed hole on the muffler's back side. Make sure it fits tightly against the muffler and is not raised up.

7. Place the exhaust gasket against muffler's back side. Align the gasket bolt holes with the bolt holes in the muffler. While holding exhaust gasket in place, insert the bolts into the muffler's front side (Fig. 27).
8. Place the muffler (with the exhaust gasket in place and bolts inserted), against the engine, aligning the bolt holes. Tighten the bolts to secure the muffler to the engine.
If using a torque wrench, torque to:
9-10.2 N•m (80-90 in.·lb.)
9. Reinstall the air filter/muffler cover.

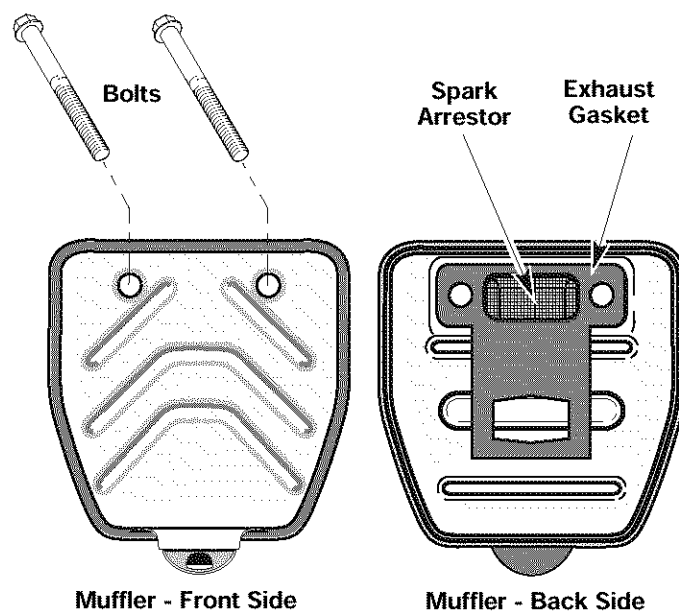
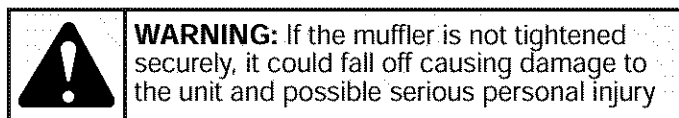

Muffler - Front Side

Muffler - Back Side

Fig. 27

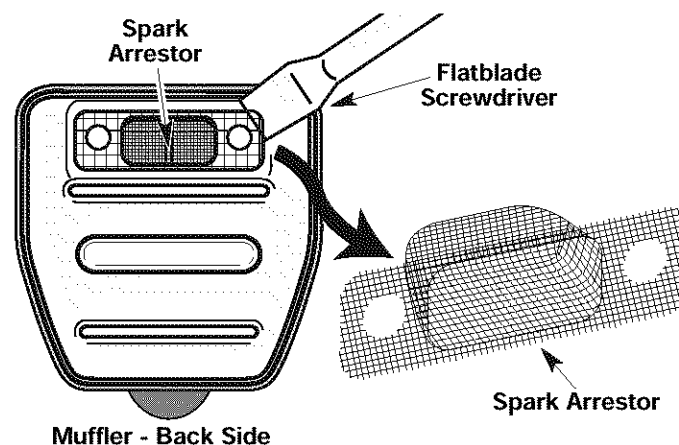

Muffler - Back Side

Spark Arrestor

Fig. 28

MAINTENANCE AND REPAIR INSTRUCTIONS

CARBURETOR ADJUSTMENT

The idle speed of the engine is adjustable through the air filter/muffler cover (Fig. 29).

NOTE: Careless adjustments can seriously damage your unit. An authorized service dealer should make carburetor adjustments.

Check Petrol Mixture

Old and/or improperly mixed petrol is usually the reason for improper unit performance. Drain and refill the tank with fresh, properly-mixed petrol prior to making any adjustments. Refer to *Oil and Petrol Information*.

Clean Air Filter

The condition of the air filter is important to the operation of the unit. A dirty air filter will restrict air flow and change the air/petrol mixture. This is often mistaken for an out of adjustment carburetor. Check the condition of the air filter before adjusting the idle speed screw. Refer to *Air Filter Maintenance*.

Adjust Idle Speed Screw

	<p>WARNING: This unit will need to be running during idle speed adjustment. Wear protective clothing and observe all safety instructions to prevent serious personal injury.</p> <p>Also, DO NOT set unit on any surface except a clean, hard area while starting or performing any adjustments. Debris such as gravel, sand, dust, grass, etc. could be picked up by the air intake and thrown out by the discharge opening, damaging unit, property, or causing serious injury to bystanders or operator.</p>
--	--

If after checking the petrol mixture and cleaning the air filter the engine still will not idle, adjust the idle speed adjuster as follows.

1. Start the engine and let it run at a high idle for a minute to warm up.
2. Set the blower/vacuum mode change-over lever to the up position (Blower Mode). Refer to *Operating as a Blower*.

NOTE: Setting the lever to the blower mode prevents the vacuum bag from filling up while starting or running the unit.

3. Move the throttle control and let the engine idle. If the engine stops, insert a small phillips or flat blade screwdriver into the hole in the air filter/muffler cover (Fig. 29). Turn the idle speed adjuster in, clockwise, 1/8 of a turn at a time (as needed) until the engine idles smoothly.
4. If the unit appears to be idling too fast, turn the idle speed adjuster counterclockwise 1/8 of a turn at a time (as needed), to reduce idle speed.

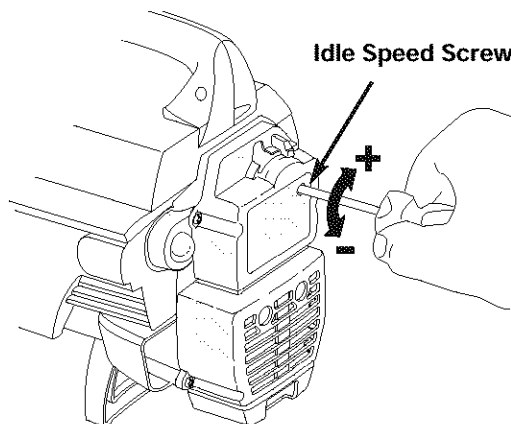

Fig. 29

Checking the petrol mixture, cleaning the air filter, and adjusting the idle speed should solve most engine problems. If not and all of the following are true:

- the engine will not idle
- the engine hesitates or stalls on acceleration
- there is a loss of engine power

Have the carburetor adjusted by an authorized service dealer.

REPLACING THE SPARK PLUG

Use a Champion RDJ7Y spark plug, or equivalent. The correct air gap is **0.5 mm (0.020 inch)**. Remove the plug after every 25 hours of operation and check its condition.

1. Stop the engine and allow it to cool. Grasp the plug wire firmly and pull it from the spark plug.
2. Clean around the spark plug. Remove the spark plug from the cylinder head by turning a 5/8-inch socket counterclockwise.
3. Replace a cracked, fouled or dirty spark plug. Set the air gap at **0.5 mm (0.020 inch)** using a feeler gauge (Fig. 30).

	<p>CAUTION: Do not sand blast, scrape or clean electrodes. Grit in the engine could damage the cylinder.</p>
---	---

4. Install a correctly-gapped spark plug in the cylinder head. Tighten by turning the 5/8-inch socket clockwise until snug.

If using a torque wrench torque to:

12.3-13.5 N•m (110-120 in.•lb)

Do not over tighten.

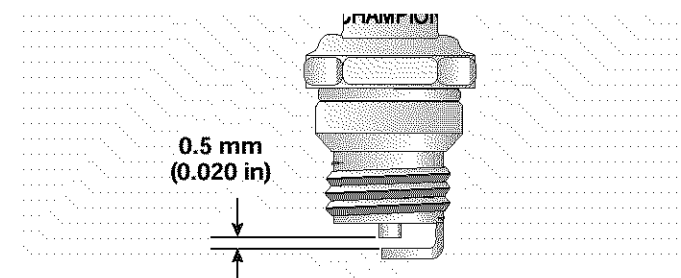

Fig. 30

MAINTENANCE AND REPAIR INSTRUCTIONS

CLEANING THE UNIT



WARNING: To avoid serious personal injury, always turn your unit off and allow it to cool before you clean or service it.

Use a small brush to clean off the outside of the unit. Do not use strong detergents. Household cleaners that contain aromatic oils such as pine and lemon, and solvents such as kerosene, can damage plastic housing or handle. Wipe off any moisture with a soft cloth.

CLEANING THE VACUUM BAG

1. Empty the bag after each use to avoid deterioration and obstructing air flow, which will reduce the performance of the vacuum.
2. Wearing eye protection and a dust mask, clean the bag as needed. Turn the bag inside out after initial emptying and vigorously shake out dust and debris.
3. Wash the bag once a year or more often if needed:
 - a. Remove the vacuum bag.
 - b. Turn bag inside out.
 - c. Hang it up.
 - d. Hose it down thoroughly.
 - e. Hang to dry.
 - f. Turn bag right-side out and reinstall.

STORAGE

- Never store a unit filled with petrol where fumes may reach an open flame or spark.
- Allow the engine to cool before storing.
- Store the unit locked up to prevent unauthorized use or damage.
- Store the unit in a dry, well-ventilated area.
- Store the unit out of the reach of children.

LONG TERM STORAGE

If you plan on storing the unit for an extended time, use the following storage procedure:

1. Drain all petrol from the petrol tank into a container with the same 2-cycle petrol mixture. Do not use petrol that has been stored for more than 60 days. Dispose of the old petrol/oil mix in accordance to Federal, State and Local regulations.

2. Start the engine and allow it to run until it stalls. This ensures that all petrol has been drained from the carburetor.
3. Allow the engine to cool. Remove the spark plug and put 30 ml (1 oz.) of any high quality motor oil or 2-cycle oil into the cylinder. Pull the starter rope slowly to distribute the oil. Reinstall the spark plug.

NOTE: Remove the spark plug and drain all of the oil from the cylinder before attempting to start the unit after storage.

4. Thoroughly clean the unit and inspect it for any loose or damaged parts. Repair or replace damaged parts and tighten loose screws, nuts or bolts. The unit is ready for storage.

TRANSPORTING

- Allow the engine to cool before transporting.
- Drain petrol from unit.
- Tighten petrol cap before transporting.
- Secure the unit while transporting.

ACCESSORIES/ REPLACEMENT PARTS

2-Cycle Oil	147543
Spark Plug	610311
Petrol Cap	180000
Vacuum Bag	182416
Blower/Vacuum Tube Assembly	182415
Shoulder Harness	682075

For specific replacement parts, refer to the parts list located on the inside back cover of this manual.

TROUBLESHOOTING

ENGINE WILL NOT START

CAUSE

Choke is in the incorrect position
 Empty petrol tank
 Primer bulb wasn't pressed enough
 Engine flooded
 Old or improperly mixed petrol
 Fouled spark plug
 Plugged spark arrestor

ACTION

Refer to the Starting/Stopping instructions
 Fill petrol tank with properly mixed petrol
 Press primer bulb fully and slowly 10 times
 Use starting procedure **WITHOUT USING** the CHOKE
 Drain petrol tank / Add fresh petrol mixture
 Replace or clean the spark plug
 Clean or replace spark arrestor

ENGINE WILL NOT IDLE

CAUSE

Air filter is plugged
 Old or improperly mixed petrol
 Improper carburetor adjustment

ACTION

Replace or clean the air filter
 Drain petrol tank / Add fresh petrol mixture
 Adjust according to the *Carburetor Adjustments* section

ENGINE WILL NOT ACCELERATE

CAUSE

Old or improperly mixed petrol
 Improper carburetor adjustment

 Dirty air filter
 Plugged spark arrestor

ACTION

Drain petrol tank / Add fresh petrol mixture
 Take to an authorized service dealer for carburetor adjustment
 Clean or replace the air filter
 Clean or replace spark arrestor

ENGINE LACKS POWER OR STALLS

CAUSE

Old or improperly mixed petrol
 Air filter is plugged
 Improper carburetor adjustment

 Fouled spark plug
 Plugged spark arrestor

ACTION

Drain petrol tank / Add fresh petrol mixture
 Replace or clean the air filter
 Take to an authorized service dealer for carburetor adjustment
 Replace or clean the spark plug
 Clean or replace spark arrestor

UNIT WILL NOT BLOW OR VACUUM

CAUSE

Bag full
 Blocked tube

 Blocked impeller

 Damaged impeller

ACTION

Empty bag, as described in *Empty the Vacuum Bag*
 Clear the blockage as described in *Clearing a Blocked Tube/ Impeller*
 Clear the blockage as described in *Clearing a Blocked Tube/ Impeller*
 Take the unit to an authorized service dealer

If further assistance is required, contact your authorized service dealer.

SPECIFICATIONS

ENGINE

Engine Type.....	Air-Cooled, 2-Cycle
Displacement.....	31 cc (1.9 cu. in)
Operating RPM.....	7,100+ rpm
Idle Speed RPM	3,600-4,800 rpm
Ignition Type.....	Electronic
On/Off Stop Control.....	Rocker Switch
Spark Plug Gap.....	0.5 mm (0.020 inch)
Lubrication	Petrol/Oil Mixture
Petrol/Oil Ratio.....	40:1
Carburetor	Diaphragm, All-Position
Starter.....	Auto Rewind
Muffler	Baffled with Guard
Petrol Tank Capacity	384 ml (13 ounces)

BLOWER / VACUUM

Throttle Control.....	Finger-Tip Lever
Blower Velocity.....	up to 257 kmh (160 mph)
Blower Air Output	up to 12.1 cmm (424 cfm)
Mulching Ratio.....	up to 10:1
Vacuum Bag Capacity	26.4 Liters (0.75 bushels)
Shoulder Harness	Optional Accessory (Single Quick-Snap)
Weight (no petrol, with blower/vacuum tube and empty vacuum bag)	6 kg (13.5 lb.)

NOTES

PARTS LIST

ENGINE PARTS - MODEL BL3100 2-CYCLE PETROL MULCHING BLOWER VACUUM

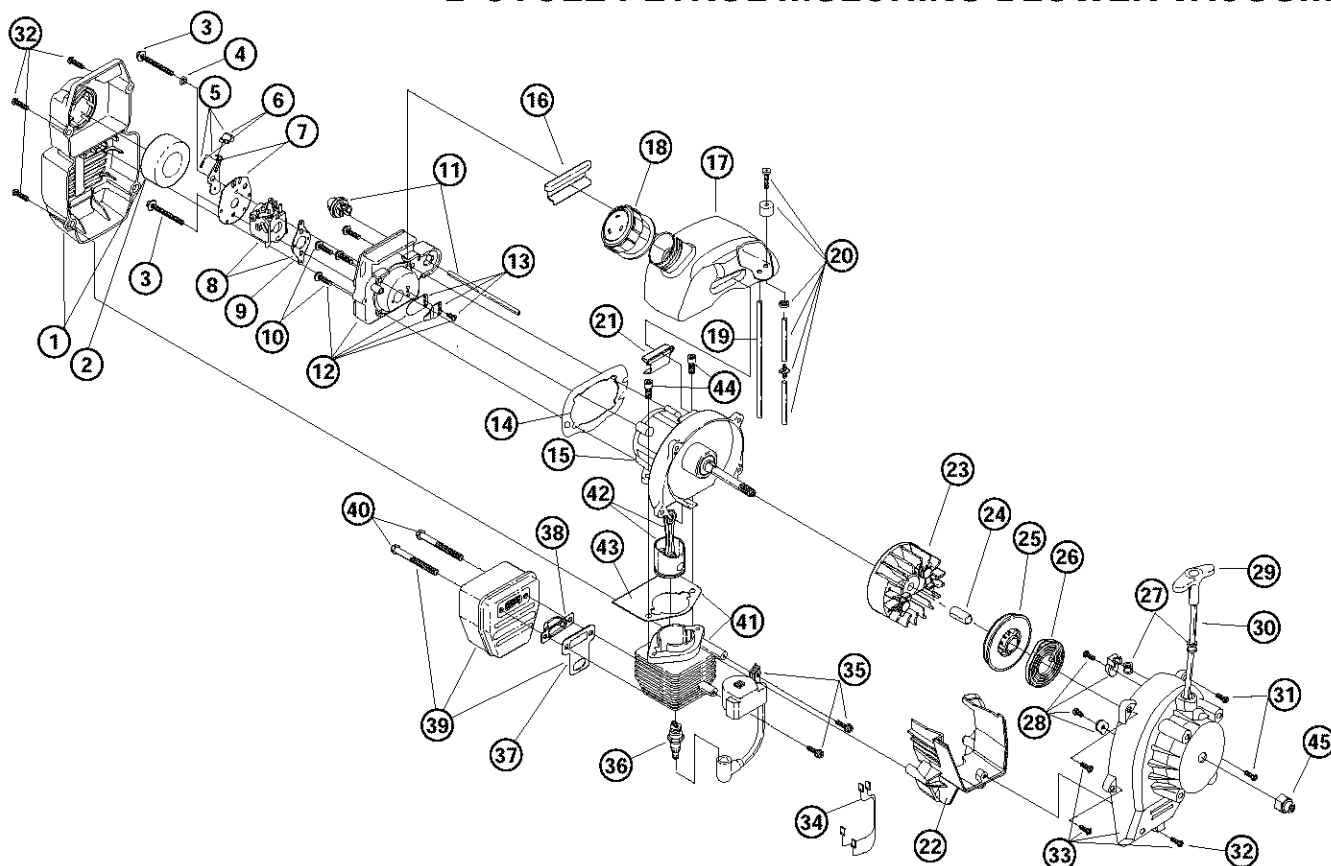

Item	Part No.	Description	Item	Part No.	Description
1	791-182059	Air Cleaner/Muffler Cover Assembly (includes 2 & 32)	27	791-611061	Rope Guide
2	791-180350B	Air Cleaner Filter	28	791-180930	Pulley Retainer Assembly
3	791-180351	Carburetor Mounting Screw	29	791-181079	Pull Handle
4	791-180226	Wavey Washer	30	791-613103	Rope
5	753-04418	Choke Lever Assembly (includes 6)	31	791-181862	Housing Screw
6	791-182161	Choke Knob and Screw	32	791-181345	Cover Screw
7	753-04419	Choke Lever and Plate (includes 5)	33	791-181931	Starter Housing Assembly (includes 25-32)
8	753-04320	Carburetor Assembly (includes 9 & 20)	34	791-182402	Wire Lead Assembly
9	791-610675	Carburetor Gasket	35	753-04463	Module Assembly
10	791-181860	Carb Mount Screw	36	791-147095	Spark Plug
11	791-683974B	Primer and Hose Assembly	37	753-04159	Exhaust Gasket
12	753-1196	Carb Mount Assembly (includes 10,13 & 14)	38	791-182747	Spark Arrestor Screen
13	791-684451	Reed Assembly	39	791-182066	Muffler Assembly (includes 37, 38 & 40)
14	753-1208	Carburetor Mount Gasket	40	791-147575	Muffler Mounting Bolt Assembly
15	753-04399	Crank Case Service Assembly (includes 10)	41	753-04323	Cylinder Assembly (includes 43 & 44)
16	791-612134	Rear Mounting Pad	42	753-04367	Piston and Rod Assembly
17	753-04310	Petrol Tank Assembly (includes 18-20)	43	753-1197	Cylinder Gasket
18	791-182438	Petrol Cap Assembly	44	791-182723	Cylinder Bolt
19	791-181168	Petrol Return Line	45	791-181524	Crankshaft Extension
20	791-682039	Petrol Line Assembly	*	753-04134	Engine Gasket Kit
21	791-145308	Front Mounting Pad	*	791-180602	O.E.M. Carburetor Repair Kit
22	791-182401	Shroud Extension (includes 32)	*	791-181069	Gasket Diaphragm Repair Kit
23	791-182736	Flywheel Assembly	*	753-1209	Piston Ring
24	791-181525	Spacer	*	753-04322	Short Block Assembly (includes 10, 15, 36, 41-44)
25	753-1199	Recoil Pulley			
26	791-613102	Recoil Spring			
			*		Items Not Shown

PARTS LIST

HOUSING PARTS - MODEL BL3100 2-CYCLE PETROL MULCHING BLOWER VACUUM

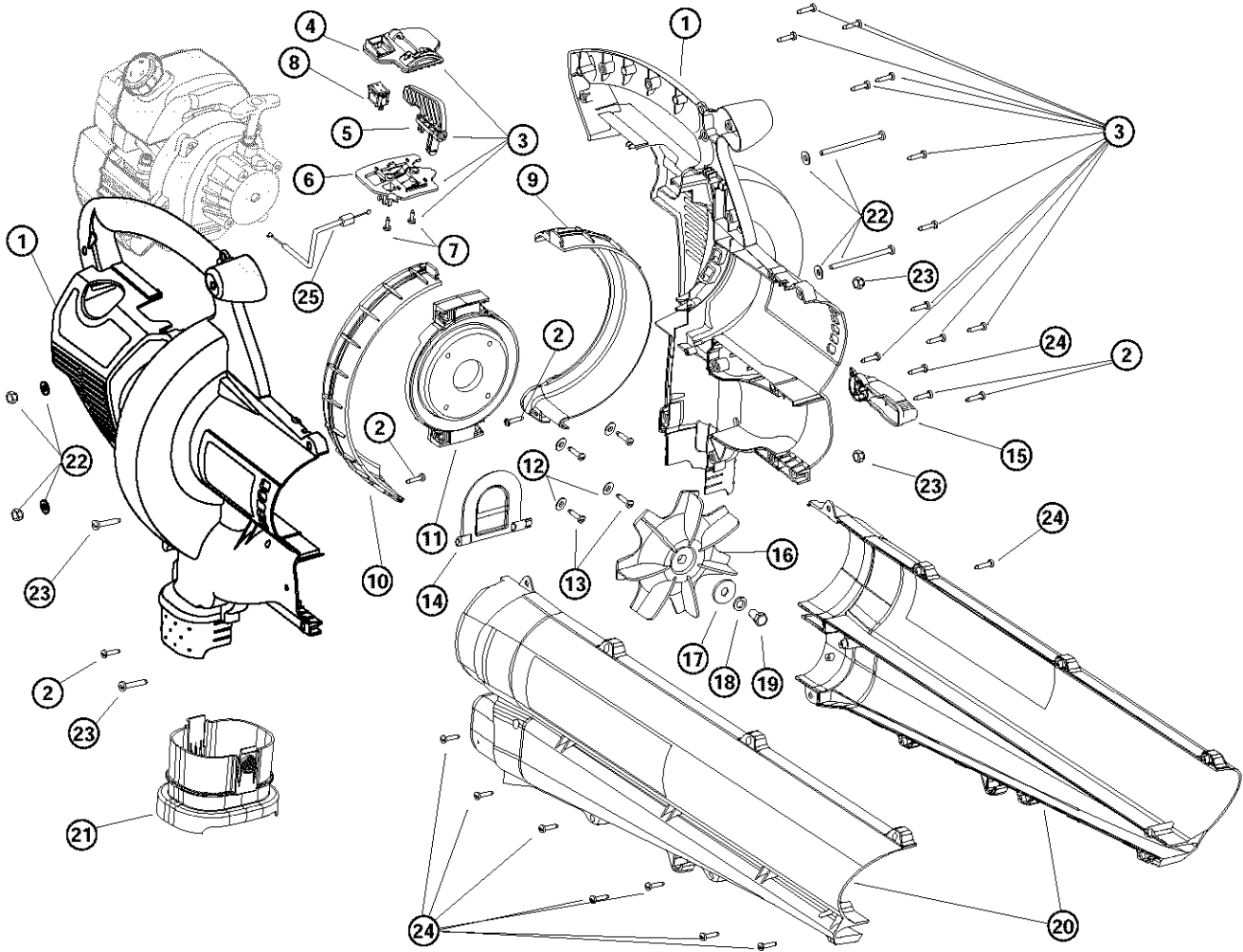

Item	Part No.	Description	Item	Part No.	Description
1	753-04464	Engine Cover Assembly (includes 2)	16	791-147353	Impeller Blade
2	791-181345	Cover Screw	17	791-182412	Washer
3	791-182419	Throttle Control Assembly (includes 4-7)	18	791-182413	Lock Washer
4	791-182420	Upper Throttle Control Plate	19	791-182414	Bolt
5	791-00048	Throttle Control Lever	20	791-00051	Blower/Vac Tube Assembly (includes 24)
6	791-182422	Lower Throttle Control Plate	21	791-182417	Vacuum Bag Adapter
7	791-182423	Screw, Plastic	22	791-182424	Mounting Plate Hardware
8	791-182405	Rocker Switch Assembly	23	791-182425	Blower/Vac Tube Mounting Hardware
9	753-04140	Left Side Liner	24	791-181482	Screw
10	753-04139	Right Side Liner	25	791-182068	Throttle Cable
11	791-182408	Engine Mounting Plate (includes 12 & 13)	*	791-612930	Cable Tie
12	791-182409	Washer	*	753-04465	Vacuum Bag Assembly (includes 21, Vacuum Bag & Cable Tie)
13	791-181903	Screw	*	753-04325	Patio Head
14	791-182410	Mode Control Flapper			
15	791-00050	Mode Control Lever (includes 24)			
			*		Items Not Shown

MANUFACTURER'S LIMITED WARRANTY FOR:



The limited warranty set forth below is given by Troy-Bilt LLC with respect with new merchandise purchased and used in the United States, its possessions and territories.

Troy-Bilt warrants this product against defects in material and workmanship for a period of two (2) years commencing on the date of original purchase and will, at its option, repair or replace, free of charge, any part found to be defective in material or workmanship. This limited warranty shall only apply if this product has been operated and maintained in accordance with the Operator's Manual furnished with the product, and has not been subject to misuse, abuse, commercial use, neglect, accident, improper maintenance, alteration, vandalism, theft, fire, water or damage because of other peril or natural disaster. Damage resulting from the installation or use of any accessory or attachment not approved by Troy-Bilt for use with the product(s) covered by this manual will void your warranty as to any resulting damage.

This warranty is limited to ninety (90) days from the date of original retail purchase for any Bolens product that is used for rental or commercial purposes, or any other income-producing purpose.

HOW TO OBTAIN SERVICE: Warranty service is available, WITH PROOF OF PURCHASE THROUGH YOUR LOCAL AUTHORIZED SERVICE DEALER. To locate the dealer in your area, please check for a listing in the Yellow Pages or contact the Customer Service Department of Troy-Bilt LLC by writing to PO Box 361131, Cleveland, Ohio 44136-0019. No product returned directly to the factory will be accepted unless prior written permission has been extended by the Customer Service Department of Troy-Bilt LLC.

This limited warranty does not provide coverage in the following cases:

- A. Tune-ups - Spark Plugs, Carburetor Adjustments, Filters
- B. Wear items - Bump Knobs, Outer Spools, Cutting Line, Inner Reels, Starter Pulley, Starter Ropes, Drive Belts
- C. Troy-Bilt does not extend any warranty for products sold or exported outside of the United States of America, its possessions and territories, except those sold through Troy-Bilt's authorized channels of export distribution.

Troy-Bilt reserves the right to change or improve the design of any Bolens Product without assuming any obligation to modify any product previously manufactured.

No implied warranty, including any implied warranty of merchantability or fitness for a particular purpose, applies after the applicable period of express written warranty above as to the parts as identified. No other express warranty or guaranty, whether written or oral, except as mentioned above, given by any person or entity, including a dealer or retailer, with respect to any product shall bind Troy-Bilt LLC. During the period of the Warranty, the exclusive remedy is repair or replacement of the product as set forth above. (Some states do not allow limitations on how long an implied warranty lasts, so the above limitation may not apply to you.)

The provisions as set forth in this Warranty provide the sole and exclusive remedy arising from the sales. Troy-Bilt LLC shall not be liable for incidental or consequential loss or damages including, without limitation, expenses incurred for substitute or replacement lawn care services, for transportation or for related expenses, or for rental expenses to temporarily replace a warranted product. (Some states do not allow limitations on how long an implied warranty lasts, so the above limitation may not apply to you.)

In no event shall recovery of any kind be greater than the amount of the purchase price of the product sold. Alteration of the safety features of the product shall void this Warranty. You assume the risk and liability for loss, damage, or injury to you and your property and/or to others and their property arising out of the use or misuse or inability to use the product.

This limited warranty shall not extend to anyone other than the original purchaser, original lessee or the person for whom it was purchased as a gift.

How State Law Relates to this Warranty: This warranty gives you specific legal rights, and you may also have other rights which vary from state to state.

TROY-BILT LLC

PO Box 361131

Cleveland, OH 44136-0019 U.S.A.

SAVE THESE INSTRUCTIONS FOR FUTURE REFERENCE