

Bolens®

Operator's Manual

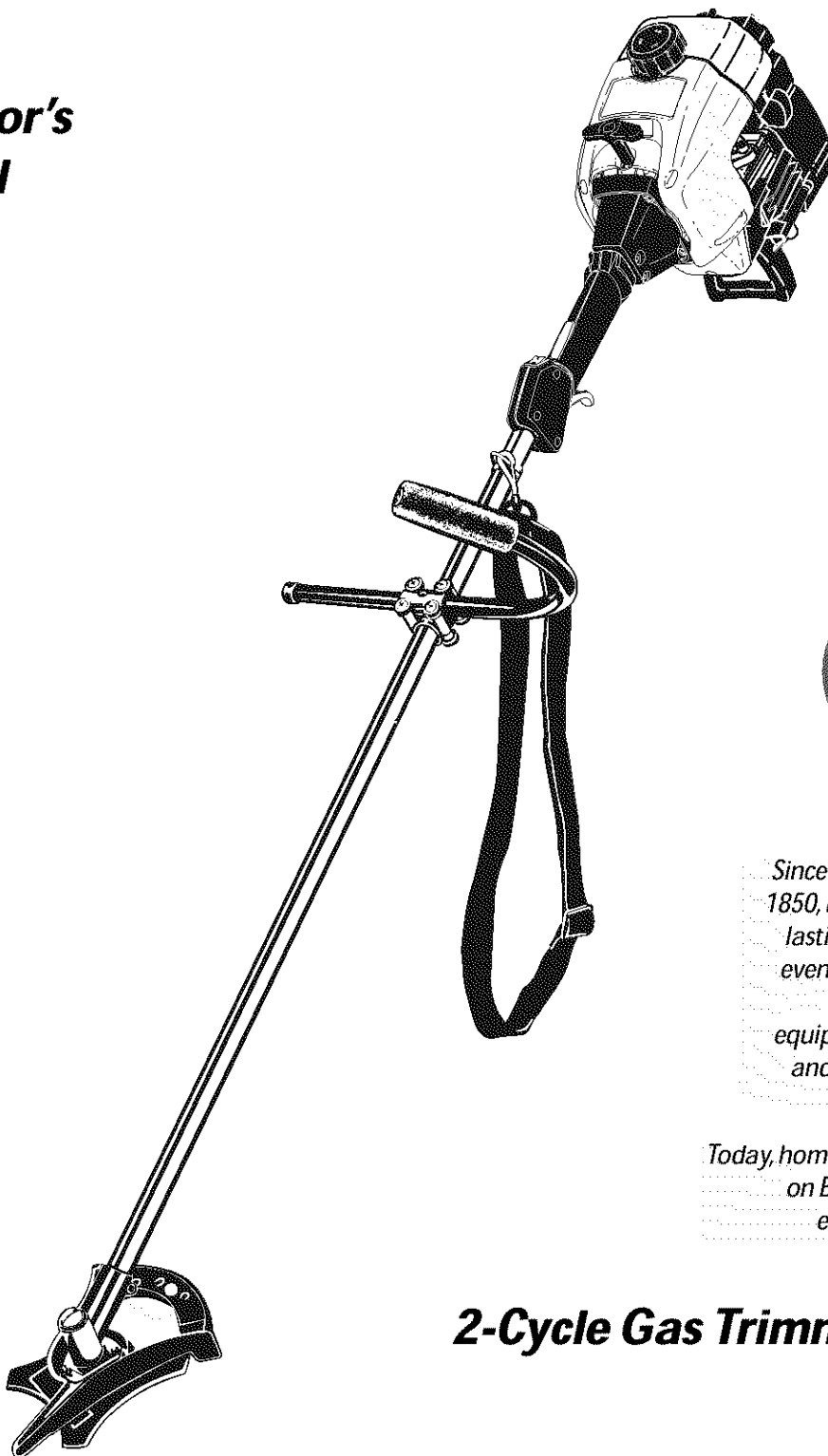

Since it began making garden tools in 1850, Bolens has been known for long-lasting, dependable products. Bolens eventually carried that hard-working heritage into the outdoor power equipment industry, when it designed and built the first-ever power-driven garden tractor.

Today, homeowners around the country rely on Bolens for durable, reliable power equipment at an affordable price.

2-Cycle Gas Trimmer/Brushcutter
Model BL250

INTRODUCTION

THANK YOU

Thank you for buying this quality product. This modern outdoor power tool will provide many hours of useful service. You will find it to be a great labor-saving device. This operator's manual provides you with easy-to-understand operating instructions. Read the whole manual and follow all the instructions to keep your new outdoor power tool in top operating condition.

PRODUCT REFERENCES, ILLUSTRATIONS AND SPECIFICATIONS

All information, illustrations, and specifications in this manual are based on the latest product information available at the time of printing. We reserve the right to make changes at any time without notice.

Bump Head™ is a trademark of MTD SOUTHWEST INC.

SplitLine™ is a trademark of MTD SOUTHWEST INC.

Copyright ©2003 MTD SOUTHWEST INC, All Rights Reserved.

SERVICE INFORMATION

Service on this unit both within and after the warranty period should be performed only by an authorized and approved service dealer.

For service call **1-800-520-5520** to obtain a list of authorized service dealers near you.

DO NOT RETURN THE UNIT TO THE RETAILER. PROOF OF PURCHASE WILL BE REQUIRED FOR WARRANTY SERVICE.

Before beginning, locate the unit's model plate. It lists the model and serial numbers of your unit. Refer to the sample plate below and copy the information for future reference.

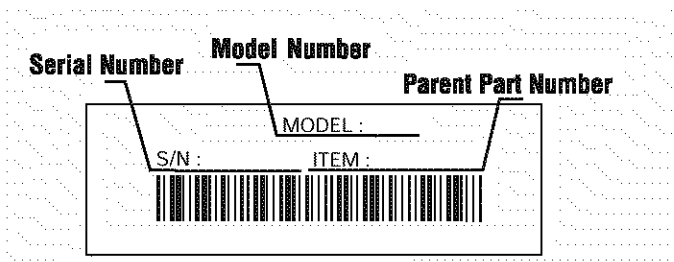

Copy the model / parent part number here: _____

Copy the serial number here: _____

Make sure you carefully read and understand this manual before starting or operating this equipment.

THIS PRODUCT IS COVERED BY ONE OR MORE U.S. PATENTS. OTHER PATENTS PENDING.

TABLE OF CONTENTS

Service Information	2
Rules for Safe Operation	3
Know Your Unit	6
Assembly Instructions	7
Oil and Fuel Information	10
Starting/Stopping Instructions	11
Operating Instructions	12
Maintenance and Repair Instructions	14
Cleaning and Storage	19
Accessories and Replacement Parts	19
Troubleshooting Chart	20
Specifications	21
Warranty Information	26
Parts List	Inside Back Cover

CONTENTS OF CARTON

- Model BL250 Trimmer/Brushcutter
 - Δ Large Bump Head Cutting Attachment
 - Δ 4-Tooth Brush Blade
 - Δ J-Handle and Hardware
 - Cutting Attachment Shield with Hardware
 - Shoulder Harness
 - Locking Rod Tool
 - Operator's Manual
 - Product Registration Card
 - Bottle of 2-Cycle Oil
- Δ This item will either be installed on the unit or in the hardware pack

Examine all parts to make certain that nothing is missing and no breakage has occurred during shipping. Any damaged or missing part must be replaced before using this product.

CALIFORNIA PROPOSITION 65 WARNING

WARNING

THE ENGINE EXHAUST FROM THIS PRODUCT CONTAINS CHEMICALS KNOWN TO THE STATE OF CALIFORNIA TO CAUSE CANCER, BIRTH DEFECTS, OR OTHER REPRODUCTIVE HARM.

RULES FOR SAFE OPERATION

NOTE: For users on U.S. Forest Land and in the states of California, Maine, Oregon, and Washington. All U.S. Forest Land and the state of California (Public Resources Codes 4442 and 4443), Oregon, and Washington require by law that certain internal combustion engines operated on forest brush and/or grass-covered areas be equipped with a spark arrestor, maintained in effective working order, or the engine be constructed, equipped, and maintained for the prevention of fire. Check with your state or local authorities for regulations pertaining to these requirements. Failure to follow these requirements could subject you to liability or a fine. **This unit is factory equipped with a spark arrestor.** If it requires replacement, ask your LOCAL SERVICE DEALER to install the **Accessory Part #182747 Spark Arrestor.**

Read the Operator's Manual(s) and follow all warnings and safety instructions.

Failure to do so can result in serious injury to the operator and/or bystanders.

FOR QUESTIONS, CALL 1-800-520-5520

• SAFETY SYMBOLS •

The purpose of safety symbols is to attract your attention to possible dangers. The safety symbols, and their explanations, deserve your careful attention and understanding. The safety warnings do not by themselves eliminate any danger. The instructions or warnings they give are not substitutes for proper accident prevention measures.

SYMBOL

MEANING



SAFETY ALERT SYMBOL: Indicates danger, warning or caution. Attention is required in order to avoid serious personal injury. May be used in conjunction with other symbols or pictographs.



DANGER: Failure to obey a safety warning will result in serious injury to yourself or to others. Always follow the safety precautions to reduce the risk of fire, electric shock and personal injury.

SYMBOL

MEANING



WARNING: Failure to obey a safety warning can result in injury to yourself and others. Always follow the safety precautions to reduce the risk of fire, electric shock, and personal injury.



CAUTION: Failure to obey a safety warning may result in property damage or personal injury to yourself or to others. Always follow the safety precautions to reduce the risk of fire, electric shock, and personal injury.

NOTE: Advises you of information or instructions vital to the operation or maintenance of the equipment.

• IMPORTANT SAFETY INFORMATION •

READ ALL INSTRUCTIONS



WARNING: When using the unit, you must follow the safety rules. Please read these instructions before operating the unit in order to ensure the safety of the operator and any bystanders. Please keep these instructions for later use.

- Clear the area to be cut before each use. Remove rocks, broken glass, nails, wire, string and other objects which may be thrown or become entangled in the cutting attachment. Clear the area of children, bystanders and pets; keep them outside a 50-foot (15 m.) radius, at a minimum. Even then, they are still at risk from thrown objects. Encourage bystanders to wear eye protection. If you are approached, stop the unit immediately.

BEFORE OPERATING

- Read the instructions carefully. Be familiar with the controls and proper use of the unit.
- Do not operate this unit when tired, ill or under the influence of alcohol, drugs or medication.
- Children under the age of 15 must not use the unit; teens may operate the unit with adult guidance.
- Inspect the unit before use. Replace damaged parts. Check for fuel leaks. Make sure all fasteners are in place and secure. Replace cutting attachment parts that are cracked, chipped or damaged in any way. Make sure the cutting attachment is properly installed and securely fastened. Be sure that the cutting attachment shield is properly attached, and positioned as recommended. Failure to do so can result in personal injury to the operator and bystanders, as well as damage to the unit.
- Use only a 0.095-inch (2.41 mm) diameter Genuine Factory Parts™ replacement line. Never use metal-reinforced line, wire, chain or rope. These can break off and become dangerous projectiles.
- Be aware of risk of injury to the head, hands and feet.
- Squeeze the throttle control and check that it returns automatically to the idle position. Make all adjustments or repairs before using the unit.

SAFETY WARNINGS FOR GAS TRIMMERS



WARNING: Gasoline is highly flammable and its vapors can explode if ignited. Follow the ensuing precautions.

- Store fuel only in containers specifically designed and approved for the storage of such materials.
- Always stop the engine and allow it to cool before filling the fuel tank. Never remove the fuel tank cap or add fuel when the engine is hot. Never operate the unit without the fuel cap securely in place. Loosen the fuel tank cap slowly to relieve any pressure in the tank.
- Add fuel in a clean, well-ventilated outdoor area where there are no sparks or flames. Remove the fuel cap slowly, and only after the engine stops. Do not smoke while fueling or mixing fuel. Wipe up any spilled fuel from the unit immediately.
- Avoid creating a source of ignition for spilled fuel. Do not start the engine until fuel vapors dissipate.

RULES FOR SAFE OPERATION

• IMPORTANT SAFETY INFORMATION •

- Move the unit at least 30 feet (9.1 m) from the fueling source and site before starting the engine. Do not smoke. Keep sparks and open flames away from the area while adding fuel or operating the unit.

WHILE OPERATING

- Never start or run the unit inside a closed room or building. Breathing exhaust fumes can be fatal. Operate this unit only in a well-ventilated outdoor area.
- Wear safety glasses or goggles that meet ANSI Z87.1 standards and are marked as such. Wear ear/hearing protection when operating this unit. Wear a face or dust mask if the operation is dusty.
- Wear heavy long pants, boots, gloves and a long sleeve shirt. Do not wear loose clothing, jewelry, short pants, sandals or go barefoot. Secure hair above shoulder level.
- The cutting attachment shield must always be in place while operating the unit. Do not operate unit without both trimming lines extended, and the proper line installed. Do not extend the trimming line beyond the length of the shield.
- This unit has a clutch. The cutting attachment remains stationary when the engine is idling. If it does not, have the unit adjusted by an authorized service technician.
- Adjust the J-handle to your size in order to provide the best grip.
- Be sure the cutting attachment is not in contact with anything before starting the unit.
- Use the unit only in daylight or good artificial light.
- Avoid accidental starting. Be in the starting position whenever pulling the starter rope. Both the operator and unit must be in a stable position while starting. Refer to the *Starting/Stopping Instructions*.
- Use the right tool. Only use this tool for its intended purpose.
- Do not overreach. Always keep proper footing and balance.
- Always hold the unit with both hands when operating. Keep a firm grip on both handles or grips.
- Keep hands, face, and feet at a distance from all moving parts. Do not touch or try to stop the cutting attachment when it rotates.
- Do not touch the engine, gear housing or muffler. These parts get extremely hot from operation, even after the unit is turned off.
- Do not operate the engine faster than the speed needed to cut, trim or edge. Do not run the engine at high speed when not cutting.
- Always stop the engine when cutting is delayed or when walking from one cutting location to another.
- If you strike or become entangled with a foreign object, stop the engine immediately and check for damage. Do not operate before repairing damage. Do not operate the unit with loose or damaged parts.
- Stop the unit, switch the engine to off, and disconnect the spark plug for maintenance or repair.
- Use only Genuine Factory Part™ replacement parts and accessories for this unit. These are available from your authorized service dealer. Use of any non-original factory parts or accessories could lead to serious injury to the user, or damage to the unit, and void your warranty.
- Keep unit clean of vegetation and other materials. They may become lodged between the cutting attachment and shield.
- To reduce fire hazard, replace a faulty muffler and spark arrestor. Keep the engine and muffler free from grass, leaves, excessive grease or carbon build up.

WHILE OPERATING WITH CUTTING BLADE

- Read and understand all safety warnings before operating this unit.
- Always use the shoulder harness when using the brush blade accessory.
- Keep the J-handle between the operator and cutting attachment or blade at all times.
- NEVER cut when the cutting blade is 30 inches (76 cm) or more above the ground level.
- Blade thrust may occur when the spinning blade contacts an object that it does not immediately cut. Blade thrust can be violent enough to propel the unit and/or operator in any direction, possibly causing a loss of control. Blade thrust can occur without warning if the blade snags, stalls or binds. This is more likely to occur in areas where it is difficult to see the material being cut.
- For operation with the brush blade, do not cut anything thicker than 1/2 inch or a violent kickback could occur.
- Do not attempt to touch or stop the blade when it is rotating.
- A coasting blade can cause injury while it continues to spin after the engine is stopped or the throttle trigger is released. Maintain proper control until the blade has completely stopped rotating.
- Do not run the unit at high speed when not cutting.
- If you strike or become entangled with a foreign object, stop the engine immediately and check for damage. Have any damage repaired before attempting further operations. Do not operate unit with a bent, cracked or dull blade. Discard blades that are bent, warped, cracked or broken.
- Do not sharpen the cutting blade. Sharpening the blade can cause the blade tip to break off while in use. This can result in severe personal injury. Replace the blade.
- Do not use the cutting blade for edging or as an edger; severe personal injury to yourself or others may incur. Use the cutting blade only for the purpose as described in this manual.
- Stop the engine IMMEDIATELY if you feel excessive vibration. Vibration is a sign of trouble. Inspect thoroughly for loose nuts, bolts or damage before continuing. Repair or replace affected parts as necessary.

After Use

- Clean cutting blades with a household cleaner to remove any gum buildup. Oil the blade with machine oil to prevent rust.
- Lock up and store the cutting blade in an appropriate area to protect the blade from unauthorized use or damage.

OTHER SAFETY WARNINGS

- Never store a fueled unit inside a building where fumes may reach an open flame or spark.
- Allow the engine to cool before storing or transporting. Be sure to secure the unit while transporting.
- Store the unit in a dry area, locked up or up high to prevent unauthorized use or damage, out of the reach of children.
- Never douse or squirt the unit with water or any other liquid. Keep handles dry, clean and free from debris. Clean after each use, see *Cleaning and Storage* instructions.
- Keep these instructions. Refer to them often and use them to instruct other users. If you loan someone this unit, also loan them these instructions.

SAVE THESE INSTRUCTIONS

RULES FOR SAFE OPERATION

SAFETY AND INTERNATIONAL SYMBOLS

This operator's manual describes safety and international symbols and pictographs that may appear on this product. Read the operator's manual for complete safety, assembly, operating and maintenance and repair information.

SYMBOL

MEANING



- **SAFETY ALERT SYMBOL**
Indicates danger, warning or caution. May be used in conjunction with other symbols or pictographs.



- **WARNING - READ OPERATOR'S MANUAL**
Read the operator's manual(s) and follow all warnings and safety instructions. Failure to do so can result in serious injury to the operator and/or bystanders.



- **WEAR EYE AND HEARING PROTECTION**
WARNING: Thrown objects and loud noise can cause severe eye injury and hearing loss. Wear eye protection meeting ANSI Z87.1 standards and ear protection when operating this unit. Use a full face shield when needed.



- **KEEP BYSTANDERS AWAY**
WARNING: Keep all bystanders, especially children and pets, at least 50 feet (15 m) from the operating area.



- **UNLEADED FUEL**
Always use clean, fresh unleaded fuel.



- **OIL**
Refer to operator's manual for the proper type of oil.



- **ON/OFF STOP CONTROL**
ON / START / RUN



- **ON/OFF STOP CONTROL**
OFF or STOP

SYMBOL

MEANING



- **THROWN OBJECTS AND ROTATING CUTTER CAN CAUSE SEVERE INJURY**
WARNING: Do not operate without the cutting attachment shield in place. Keep away from the rotating cutting attachment.



- **HOT SURFACE WARNING**
Do not touch a hot muffler, gear housing or cylinder. You may get burned. These parts get extremely hot from operation. They remain hot for a short time after the unit is turned off.



- **SHARP BLADE**
WARNING: Sharp blade on cutting attachment shield. To prevent serious injury, do not touch line cutting blade.



- **CHOKE CONTROL**
A • FULL choke position
B • PARTIAL choke position
C • RUN position



- **BRUSHCUTTERS • REPLACE DULL BLADES**
Do not sharpen the cutting blade. Sharpening the blade can cause the blade tip to break off while in use. This can result in severe personal injury.



- **TRIMMER/BRUSHCUTTER SAFETY**
WARNING: Thrown objects and rotating cutter can cause severe injury. Keep bystanders, especially children and pets, at least 50 feet (15 m) away from the cutting area. The cutting attachment shield must be used when using the trimmer cutting attachment.

RULES FOR SAFE OPERATION

KNOW YOUR UNIT

Applications

As a trimmer:

- Cutting grass and light weeds
- Edging
- Decorative trimming around trees, fences, etc.

As a brushcutter:

- Cutting weeds and light bush of up to 1/2 inch in diameter

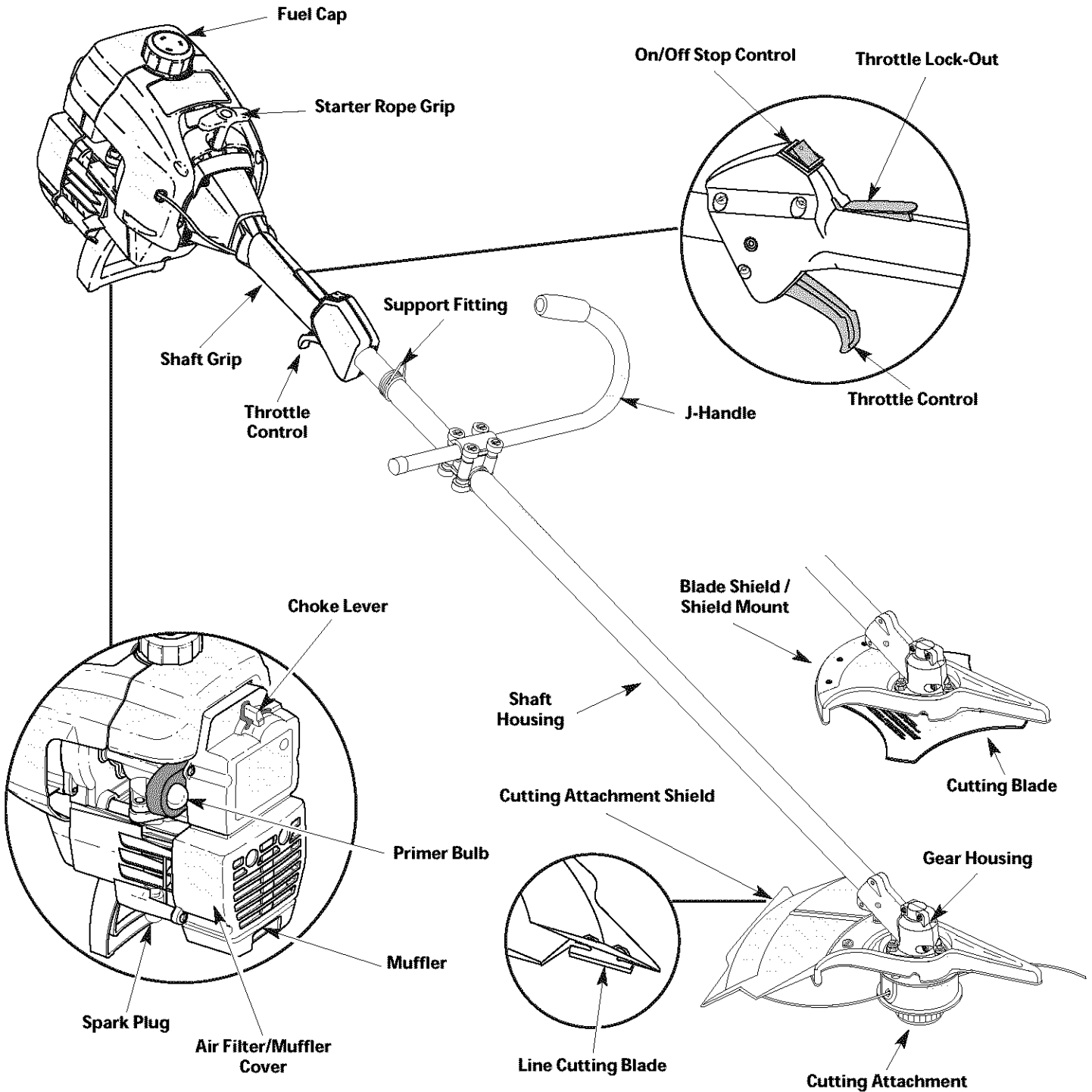

ASSEMBLY INSTRUCTIONS

On some units, the J-handle may be pre-installed. In this case you must loosen screws and adjust the handle to fit the operator. Go to step 5 if the J-handle is pre-installed.

INSTALL AND ADJUST THE J-HANDLE

1. Place the J-handle between the top and middle clamp pieces (Fig. 1).

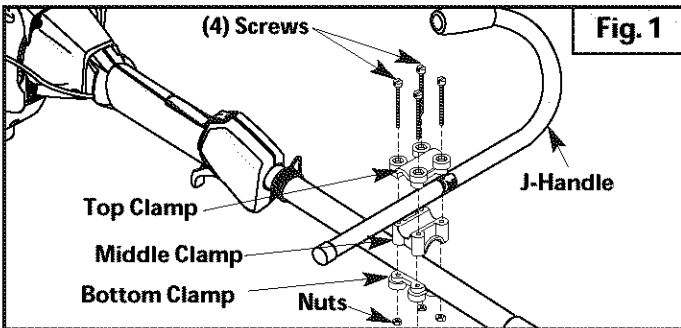

2. While holding the three pieces together, install the four (4) screws through the top clamp and into middle clamp.

NOTE: The holes in the top and middle clamp will line up only when assembled correctly.

3. Place the clamps and the J-handle over the shaft housing and onto the bottom clamp.
4. Hold each hex nut in the bottom clamp recess with a finger. Start screws with a large Phillips screwdriver. Do not tighten until you make the handle adjustment.
5. Slide the J-handle in or out until the arrow/white line on the decal touches the clamp assembly (Fig. 2). You must first loosen the screws if the handle is pre-installed.

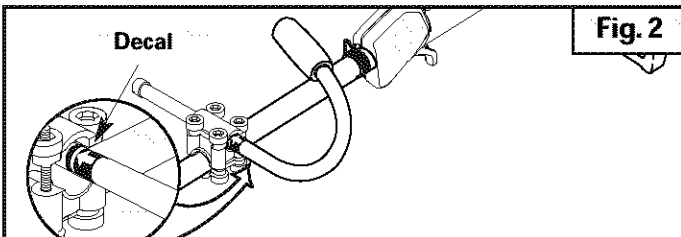

6. While holding the unit in the operating position (Fig. 3), move the J-handle to the location that provides you the best grip.



7. Tighten the clamp screws evenly, until the J-handle is secure.

INSTALL THE HARNESS



WARNING: Always use the shoulder harness when using the cutting blade to avoid serious personal injury.

1. Push the strap through the center of the buckle.
2. Pull the strap over the cross bar and down through the slot in the buckle (Fig. 4).
3. Put the harness on over your head and onto your shoulder. Snap it on to the support fitting (Fig. 5).
4. Adjust the length to fit the operator's size. Pull the tab to lengthen, pull the strap to shorten (Fig 6).

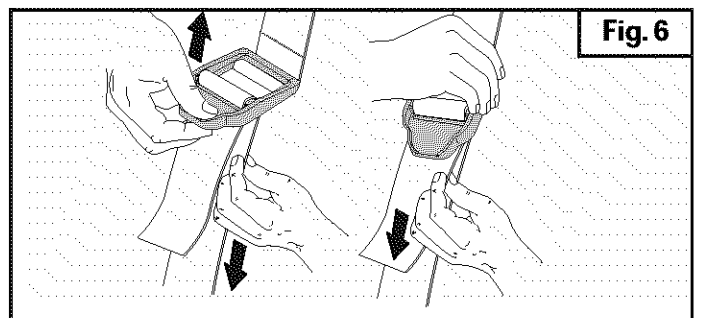
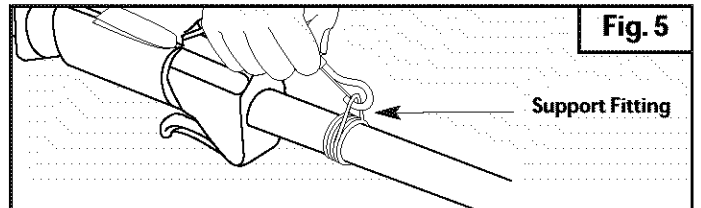
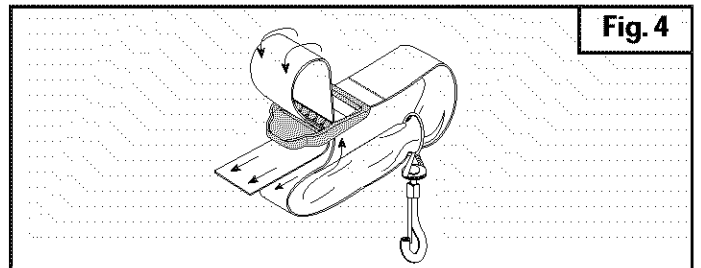

REMOVE AND INSTALL THE CUTTING ATTACHMENT SHIELD

Remove the cutting attachment shield when using the unit as a brushcutter



WARNING: The cutting attachment shield must NOT be installed when operating the unit with a blade. Remove the cutting attachment shield before removing or installing the blade.

Remove the cutting attachment shield from the shield mount by removing the three (3) screws with a flat blade screwdriver (Fig. 7). Store parts for future use.

ASSEMBLY INSTRUCTIONS

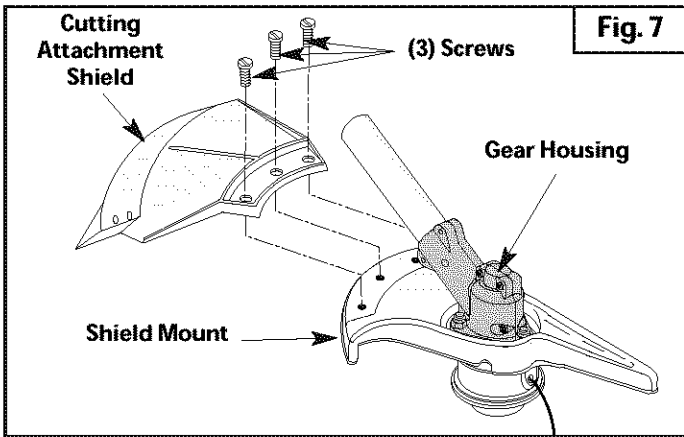

Install the cutting attachment shield when using the unit as a grass trimmer

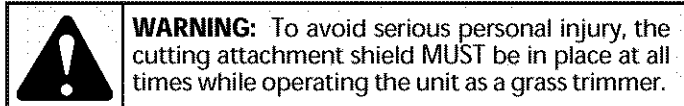

WARNING: To avoid serious personal injury, the cutting attachment shield **MUST** be in place at all times while operating the unit as a grass trimmer.

Install the cutting attachment shield on the shield mount by inserting the three (3) screws into the shield mount. Tighten securely with a flat blade screwdriver (Fig. 7).

REMOVE THE CUTTING ATTACHMENT AND INSTALL THE CUTTING BLADE

NOTE: To make cutting blade removal and installation easier, place the unit on the ground or on a work bench.

Remove the Cutting Attachment Shield

See *Remove and Install the Cutting Attachment Shield*.

Remove the Cutting Attachment

1. Align the shaft bushing hole with the locking rod slot and insert the locking rod into the shaft bushing hole (Fig. 8).

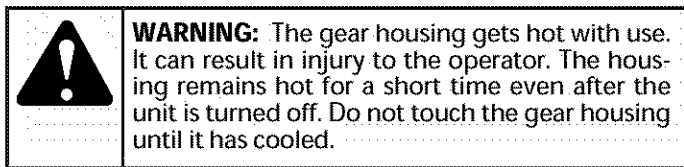

WARNING: The gear housing gets hot with use. It can result in injury to the operator. The housing remains hot for a short time even after the unit is turned off. Do not touch the gear housing until it has cooled.

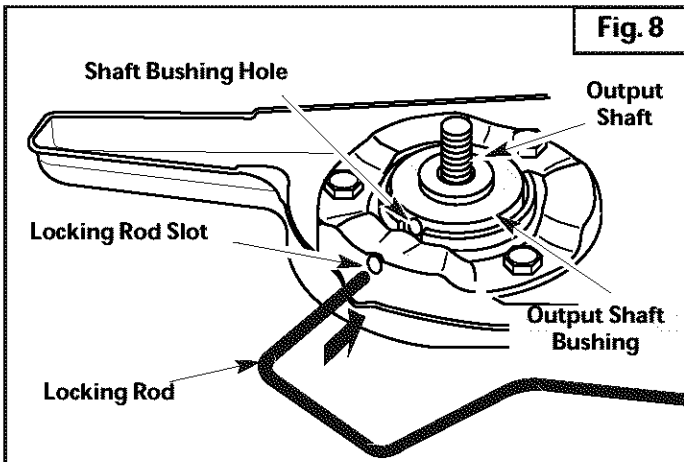

2. Hold the locking rod in place by grasping it next to the boom of the unit (Fig. 9).
3. While holding the locking rod, remove the cutting attachment by turning it clockwise off of the output shaft (Fig. 10). Store the cutting attachment for future use.

NOTE: The blade retainer under the cutting attachment will be used when installing the cutting blade.

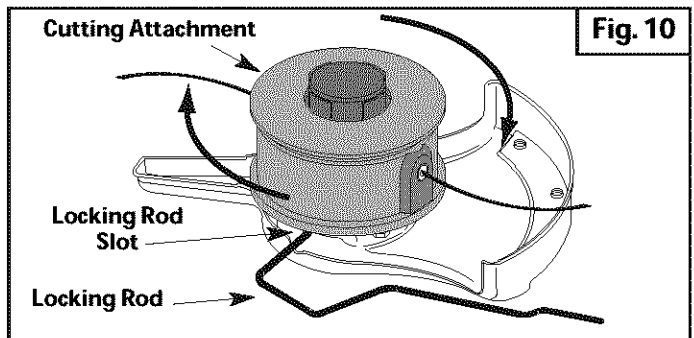
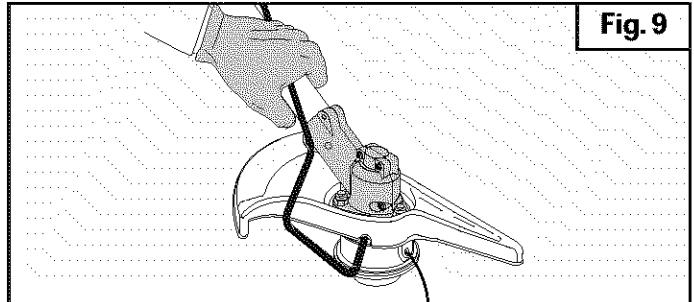

Install the Cutting Blade

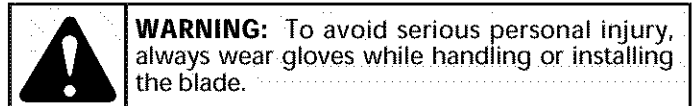

WARNING: To avoid serious personal injury, always wear gloves while handling or installing the blade.

4. Place the cutting blade on the output shaft bushing (Fig. 11).

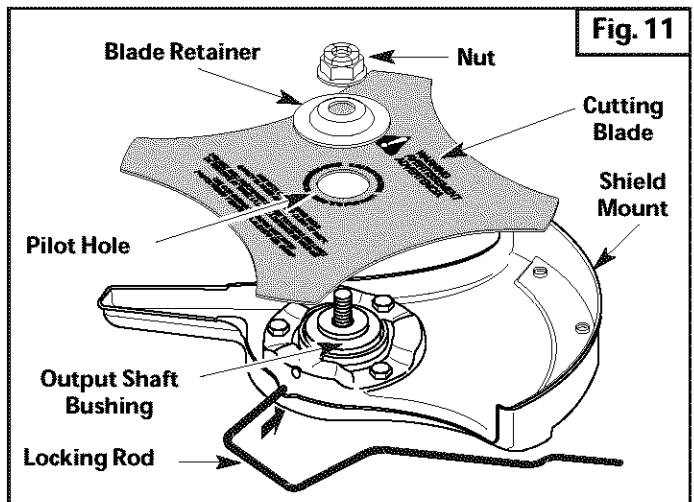

ASSEMBLY INSTRUCTIONS

- Make sure that the cutting blade is centered on the pilot step and sitting flat against the output shaft bushing (Fig. 12).

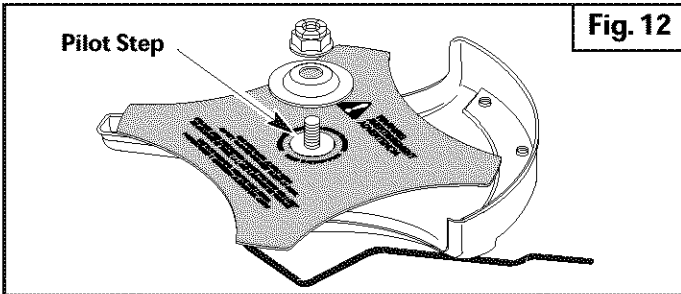
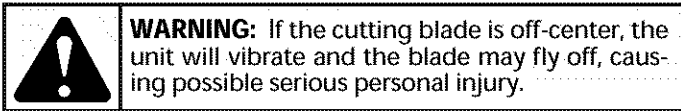

- Align the shaft bushing hole with the locking rod slot and insert the locking rod into the bushing hole (Fig. 8).
- Put the blade retainer and nut on the output shaft. Make sure that the blade is installed correctly.
- Tighten nut counterclockwise against the blade while holding the locking rod:
 - If using a torque wrench and an 5/8 inch socket, tighten to: **325 - 335 in·lb, 27 - 28 ft·lb, 37 - 38 N·m.**
 - Without a torque wrench, use a 5/8 inch closed-end or socket wrench, turning the nut until the blade retainer is snug against the shaft bushing. Make sure that the blade is installed correctly, then rotate the nut an additional 1/4 to 1/2 turn counterclockwise (Fig. 13).

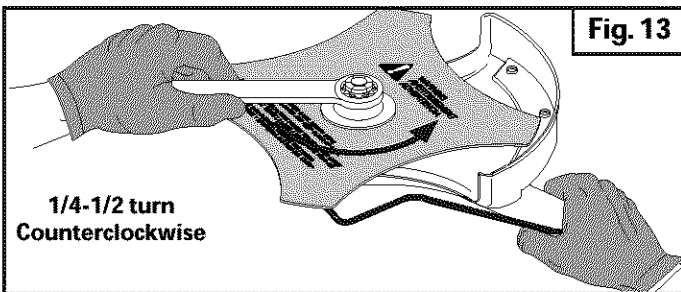

- Remove the locking rod from the locking rod slot.

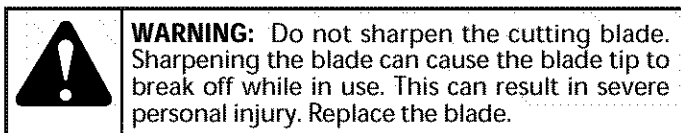
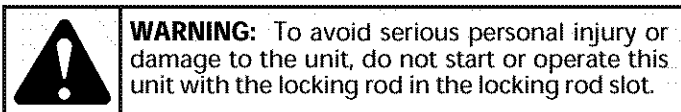

REMOVE THE CUTTING BLADE AND INSTALL THE CUTTING ATTACHMENT

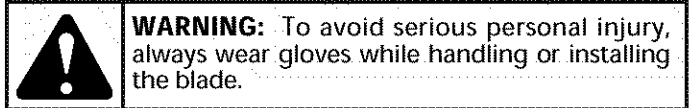

Remove the Cutting Blade

- Align the shaft bushing hole with the locking rod slot and insert the locking rod into the bushing hole (Fig. 8).
- Hold the locking rod in place by grasping it next to the boom of the unit (Fig. 14).
- While holding the locking rod, loosen the nut on the blade by turning it clockwise with a 5/8 inch closed-end or socket wrench (Fig. 14).

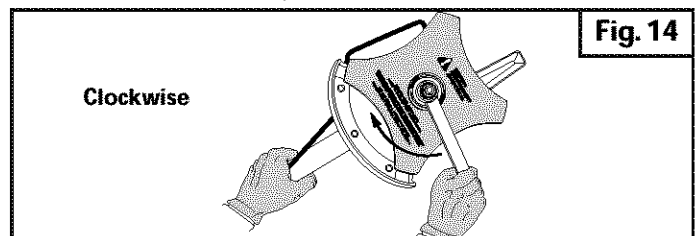

- Remove the nut, blade retainer and blade. Store the nut and blade together for future use in a secure place. Store out of children's reach.

Install the Cutting Attachment

- Align the shaft bushing hole with the locking rod slot and insert the locking rod into the shaft bushing hole (Fig. 8). Place the blade retainer on the output shaft with the flat surface against the output shaft bushing as shown in Fig. 15. Screw the cutting attachment counterclockwise onto the output shaft. Tighten securely.

NOTE: The blade retainer must be installed on the output shaft in the position shown for the cutting attachment to work correctly.

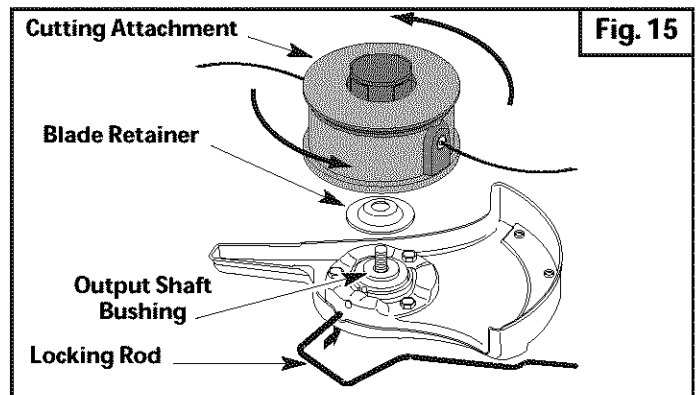

- Remove the locking rod.
- Install the cutting attachment shield. Refer to *Remove and Install the Cutting Attachment Shield*.

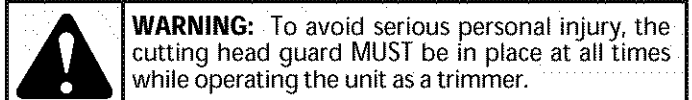

OIL & FUEL INFORMATION

OIL AND FUEL MIXING INSTRUCTIONS

Old and/or improperly mixed fuel are the main reasons for improper unit performance. Be sure to use fresh, clean unleaded fuel. Follow the instructions carefully for the proper fuel/oil mixture.

Definition of Blended Fuels

Today's fuels are often a blend of gasoline and oxygenates such as ethanol, methanol, or MTBE (ether). Alcohol-blended fuel absorbs water. As little as 1% water in the fuel can make fuel and oil separate. It forms acids when stored. When using alcohol-blended fuel, use fresh fuel (less than 60 days old).

Using Blended Fuels

If you choose to use a blended fuel, or its use is unavoidable, follow recommended precautions:

- Always use the fresh fuel mix explained in your operator's manual
- Always agitate the fuel mix before fueling the unit
- Drain the tank and run the engine dry before storing the unit

Using Fuel Additives



The bottle of 2-cycle oil that came with your unit contains a fuel additive which will help inhibit corrosion and minimize the formation of gum deposits. It is recommended that you use our 2-cycle oil with this unit.

If unavailable, use a good 2-cycle oil designed for air-cooled engines along with a fuel additive, such as STA-BIL® Gas Stabilizer or an equivalent. Add 0.8 oz. (23 ml.) of fuel additive per gallon of fuel according to the instructions on the container. NEVER add fuel additives directly to the unit's fuel tank.

	CAUTION: For proper engine operation and maximum reliability, pay strict attention to the oil and fuel mixing instructions on the 2-cycle oil container. Using improperly mixed fuel can severely damage the engine.
---	---

Thoroughly mix the proper ratio of 2-cycle engine oil with unleaded gasoline in a separate fuel can. Use a 40:1 fuel/oil ratio. Do not mix them directly in the engine fuel tank. See the table below for specific gas and oil mixing ratios.

NOTE: One gallon (3.8 liters) of unleaded gasoline mixed with one 3.2 oz. (95 ml.) bottle of 2-cycle oil makes a 40:1 fuel/oil ratio.

	+	
UNLEADED GAS		2 CYCLE OIL
1 US. GALLON (3.8 LITERS)		3.2 FL OZs. (95 ml)
1 LITER		25 ml

MIXING RATIO = 40 : 1

	WARNING: Gasoline is extremely flammable. Ignited Vapors may explode. Always stop the engine and allow it to cool before filling the fuel tank. Do not smoke while filling the tank. Keep sparks and open flames at a distance from the area.
--	--

	WARNING: Remove fuel cap slowly to avoid injury from fuel spray. Never operate the unit without the fuel cap securely in place.
---	--

	WARNING: Add fuel in a clean, well ventilated area outdoors. Wipe up any spilled fuel immediately. Avoid creating a source of ignition for spilled fuel. Do not start the engine until fuel vapors dissipate.
---	--

NOTE: Dispose of the old fuel/oil mix in accordance to Federal, State and Local regulations.

STARTING/STOPPING INSTRUCTIONS



STARTING INSTRUCTIONS





WARNING: Operate this unit only in a well-ventilated outdoor area. Carbon monoxide exhaust fumes can be lethal in a confined area.



WARNING: Avoid accidental starting. Make sure you are in the starting position when pulling the starter rope (Fig. 18). To avoid serious injury, the operator and unit must be in a stable position while starting.

1. Mix gas with oil. Fill fuel tank with fuel/oil mixture. Refer to *Oil and Fuel Mixing Instructions*.
2. Put the On/Off Stop Control in the **ON (I)** position (Fig. 16).
3. Fully press and release the primer bulb 10 times, slowly, until **FUEL IS VISIBLE IN THE PRIMER BULB** (Fig. 17). If you can't see fuel in the bulb, press and release the bulb as many times as it takes before you can see fuel in it.
4. Place the choke lever in the **FULL** choke (A)  position (Fig. 17).
5. While pressing the throttle lock-out, squeeze the throttle control to the wide open (full throttle) position (Fig. 16).
6. With the unit in the starting position (Fig. 18) pull the starter rope briskly 5 times in the **FULL** choke (A)  position. If the engine attempts to run before the fifth pull, proceed to step 7.

NOTE: The engine will not run in the **FULL** choke (A)  position.

7. Place the choke lever in the **PARTIAL** choke (B)  position (Fig. 17).
8. Pull starter rope briskly 1 to 3 times to start the engine (Fig. 18).

NOTE: Squeeze the throttle control until the engine has started and warmed up.

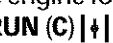
9. If the engine does not start, repeat steps 3 through 8.
10. Squeeze the throttle control to warm up the engine for 5 to 10 seconds. Place the choke lever in the **RUN** (C)  position (Fig. 17).

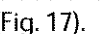
NOTE: Choking is unnecessary when starting a warm engine. Put the On/Off Stop Control in the **ON** position (Fig. 16), and start in **PARTIAL** choke (B)  position (Fig. 17). After starting, place the choke lever in the **RUN** (C)  position (Fig. 17).

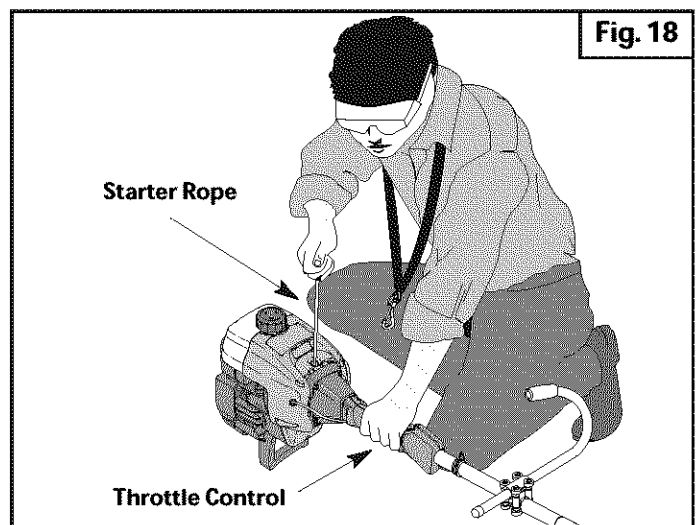
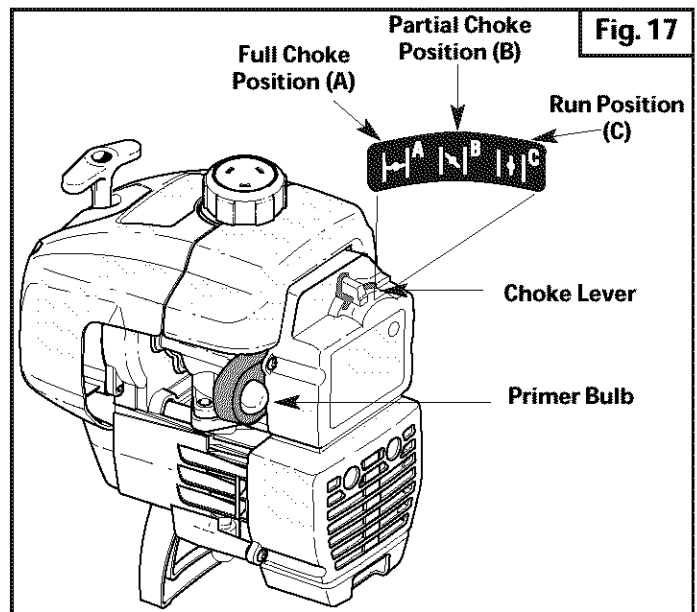
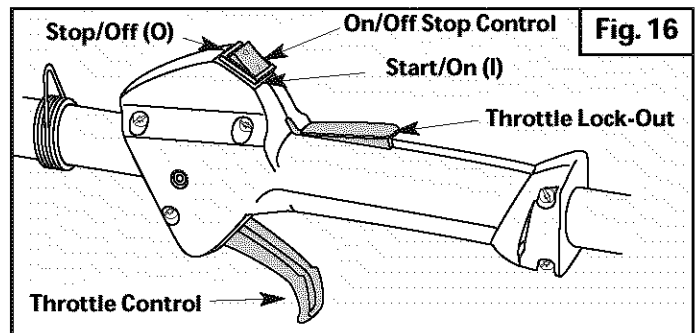

STOPPING INSTRUCTIONS

1. Release your hand from the throttle control (Fig. 18). Allow the engine to cool down by idling.
2. Put the On/Off Stop Control in the **OFF (O)** position (Fig. 16).

OPERATING INSTRUCTIONS

HOLDING THE TRIMMER



WARNING: Always wear eye, hearing, foot and body protection to reduce the risk of injury when operating this unit.

Before operating the unit, stand in the operating position (Fig. 19). Check for the following:

- The operator is wearing eye protection and proper clothing
- With a slightly-bent right arm, the operator's right hand is holding the shaft grip
- The operator's left arm is straight, the left hand holding the J-handle
- The unit is at waist level
- The cutting attachment is parallel to the ground and easily contacts the grass without the need to bend over

Once you are in the operating position, hook the shoulder strap to the unit.

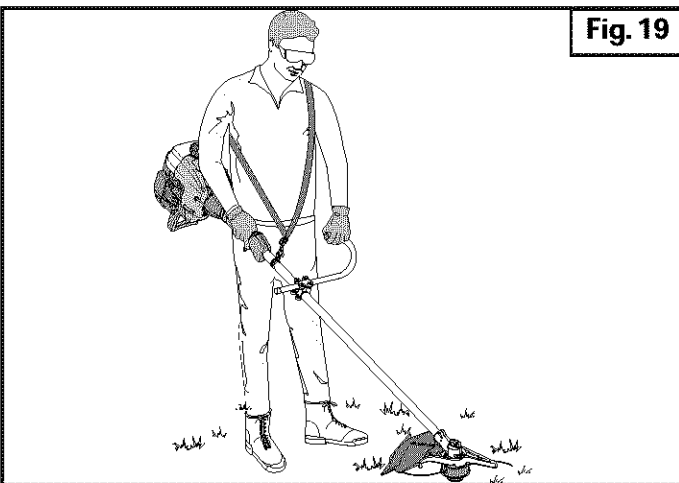

Fig. 19

Each time the head is bumped, about 1 inch (25.4 mm) of trimming line is released. A blade in the cutting attachment shield will cut the line to the proper length if excess line is released.

For best results, tap the Bump Head™ on bare ground or hard soil. If line release is attempted in tall grass, the engine may stall. Always keep the trimming line fully extended. Line release becomes more difficult as the cutting line becomes shorter.

NOTE: Do not rest the Bump Head™ on the ground while the unit is running.



CAUTION: Do not remove or alter the line cutting blade assembly. Excessive line length will make the clutch overheat. This may lead to serious personal injury or damage to the unit.

Some line breakage will occur from:

- Entanglement with foreign matter
- Normal line fatigue
- Attempting to cut thick, stalky weeds
- Forcing the line into objects such as walls or fence posts

TIPS FOR BEST TRIMMING RESULTS

- For best trimming results, operate unit at full throttle.
- Keep the cutting attachment parallel to the ground.
- Do not force the cutting attachment. Allow the tip of the line to do the cutting, especially along walls. Cutting with more than the tip will reduce cutting efficiency and may overload the engine.
- Cut grass over 8 inches (200 mm) by working from top to bottom in small increments to avoid premature line wear or engine drag.
- Cut from left to right whenever possible. Cutting to the right improves the unit's cutting efficiency. Clippings are thrown away from the operator.
- Slowly move the trimmer into and out of the cutting area at the desired height. Move either in a forward-backward or side-to-side motion. Cutting shorter lengths produces the best results.
- Trim only when grass and weeds are dry.
- The life of your cutting line is dependent upon:
 - Proper adherence of trimming techniques (explained above)
 - What vegetation is cut
 - Where vegetation is cut

For example, the line will wear faster when trimming against a foundation wall as opposed to trimming around a tree.

ADJUSTING TRIMMING LINE LENGTH

The Bump Head™ cutting attachment allows you to release trimming line without stopping the engine. To release more line, lightly tap the cutting attachment on the ground (Fig. 20) while operating the trimmer at high speed.

NOTE: Always keep the trimming line fully extended. Line release becomes more difficult as the cutting line becomes shorter.

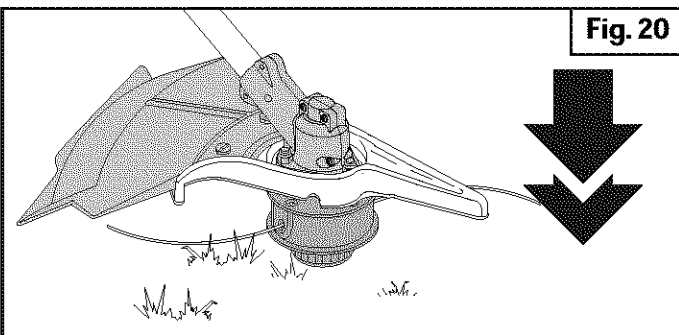

Fig. 20

OPERATING INSTRUCTIONS

DECORATIVE TRIMMING

Decorative trimming is accomplished by removing all vegetation around trees, posts, fences and more.

Rotate the whole unit so that the cutting attachment is at a 30° angle to the ground (Fig. 21).

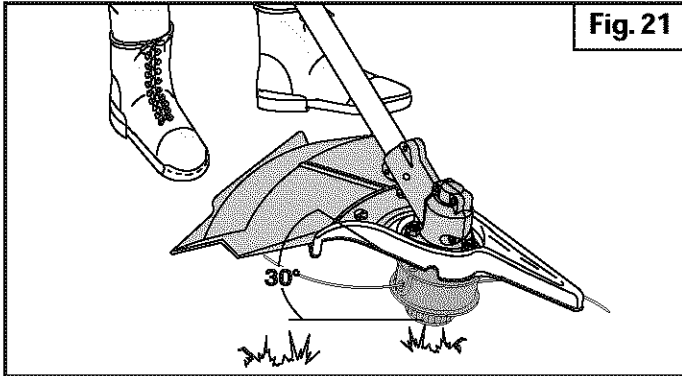

USING THE CUTTING BLADE

WARNING: Always wear eye, hearing, foot, body protection and the shoulder strap to reduce the risk of injury when operating this unit.

WARNING: Do not use the cutting blade for edging or as an edger. Severe personal injury to yourself or others can result.

Before operating the unit with the cutting blade, stand in the operating position (Fig. 22). Refer to *Holding the Trimmer*.

Cutting Blade Operating Tips

To establish a rhythmic cutting procedure:

- Plant feet firmly, comfortably apart.
- Bring the engine to full throttle before entering the material to be cut. At full throttle the blade has maximum cutting power and is less likely to bind, stall or cause blade thrust (which can result in serious personal injury to the operator or others).
- Cut while swinging the upper part of your body from left to right

WARNING: Blade thrust may occur when the spinning blade contacts an object that it does not immediately cut. Blade thrust can be violent enough to cause the unit and/or operator to be propelled in any direction, and possibly lose control of the unit. Blade thrust can occur without warning if the blade snags, stalls or binds. This is more likely to occur in areas where it is difficult to see the material being cut.

- Always release the throttle trigger and allow the engine to return to idle speed when not cutting.
- When you are finished, always unsnap the unit from the harness before taking off the harness.

WARNING: The blade continues to spin after the engine is turned off. The coasting blade can seriously cut you if accidentally touched.

- Swing the unit in the opposite direction as the blade spins, which increases the cutting action.
- After the return swing, move forward to the next area to be cut plant your feet again.
- The cutting blade is designed with a second cutting edge. You can use it by removing the blade, turning it upside down, and reinstalling it.

WARNING: Do not sharpen the cutting blade. Sharpening the blade can cause the blade tip to break off while in use. This can result in severe personal injury to yourself or others. Replace the blade.

To reduce the chance of material wrapping around the blade, follow these steps:

- Cut at full throttle
- Swing the unit into material to be cut from your left to your right (Fig. 23)
- Avoid the material just cut as you make the return swing

WARNING: Do not clear away any cut material with the engine running or blade turning. To avoid serious personal injury, turn off the engine. Allow the blade to stop before removing materials wrapped around the blade shaft.

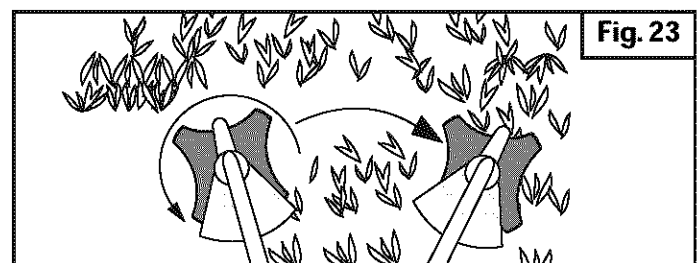
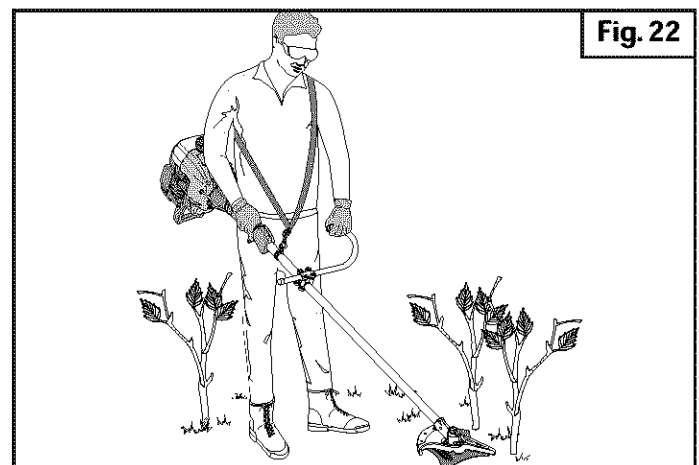

MAINTENANCE & REPAIR INSTRUCTIONS

MAINTENANCE SCHEDULE

Perform these required maintenance procedures at the frequency stated in the table. These procedures should also be a part of any seasonal tune-up.

NOTE: Some maintenance procedures may require special tools or skills. If you are unsure about these procedures take your unit to any non-road engine repair establishment, individual or authorized service dealer.



WARNING: To prevent serious injury, never perform maintenance or repairs with unit running. Always service and repair a cool unit. Disconnect the spark plug wire to ensure that the unit cannot start.

NOTE: Maintenance, replacement, or repair of the emission control devices and system may be performed by any non-road engine repair establishment, individual or authorized service dealer.

In order to assure peak performance of your engine, inspection of the engine exhaust port may be necessary after 50 hours of operation. If you notice lost RPM, poor performance or general lack of acceleration, this service may be required. If you feel your engine is in need of this inspection, refer service to any non-road engine repair establishment, individual or authorized service dealer for repair. **DO NOT** attempt to perform this process yourself as engine damage may result from contaminants involved in the cleaning process for the port.

FREQUENCY	MAINTENANCE REQUIRED	REFER TO
Before starting engine	Fill fuel tank with fresh fuel	Page 10
Every 10 hours	Clean and re-oil air filter	Page 16
Every 25 hours	Check and clean spark arrestor Check spark plug condition and gap	Page 17 Page 18
Every 50 hours	Inspect exhaust port and spark arrestor screen for clogging or obstruction to assure maximum performance levels	Page 17

LINE INSTALLATION

This section covers both SplitLine™ and standard single line installation.

Always use Genuine Factory Parts™ 0.095 in. (2.41 mm) replacement line. Line other than the specified may make the engine overheat or fail.



WARNING: Never use metal-reinforced line, wire, chain or rope. These can break off and become dangerous projectiles.

There are two methods to replace the trimming line:

- Wind the inner reel with new line
- Install a prewound inner reel

Winding the Existing Inner Reel

1. Hold the outer spool with one hand and unscrew the Bump Knob clockwise (Fig. 24). Inspect the bolt inside the bump knob to make sure it moves freely. Replace the bump knob if damaged.

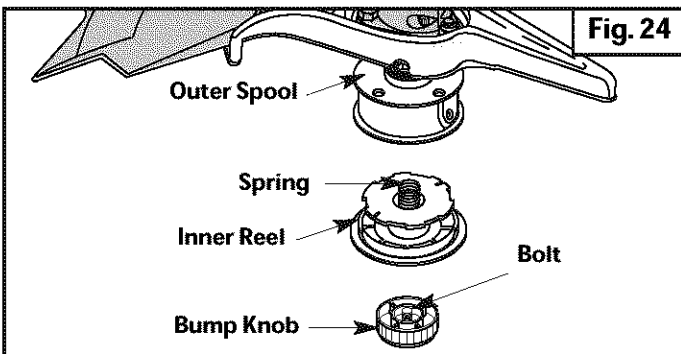

2. Remove the inner reel from the outer spool (Fig. 24).
3. Remove spring from the inner reel (Fig. 24).
4. Use a clean cloth to clean the the inner reel, spring, shaft and inner surface of the outer spool (Fig. 25).
5. Check the indexing teeth on the inner reel and outer spool for wear (Fig. 26). If necessary, remove burrs or replace the reel and spool.

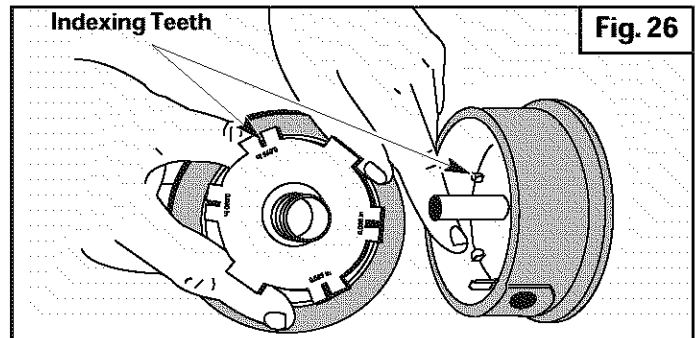
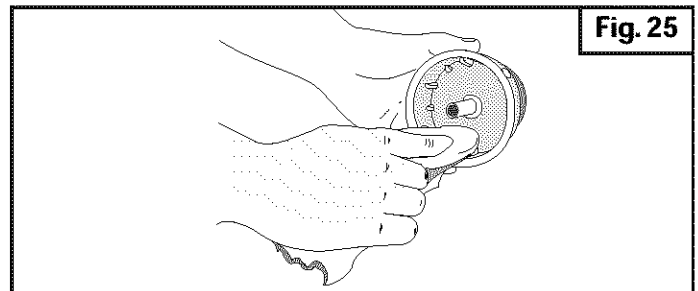

MAINTENANCE & REPAIR INSTRUCTIONS

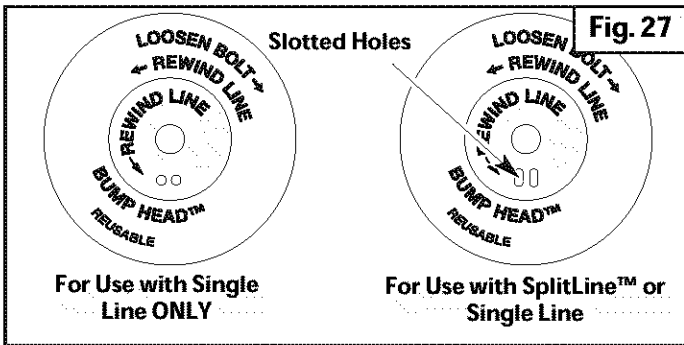

NOTE: SplitLine™ can only be used with the inner reel with the slotted holes. Single line can be used on either type of inner reel. Use Figure 27 to identify the inner reel you have.

NOTE: Always use the correct line length when installing trimming line on the unit. The line may not release properly if the line is too long.

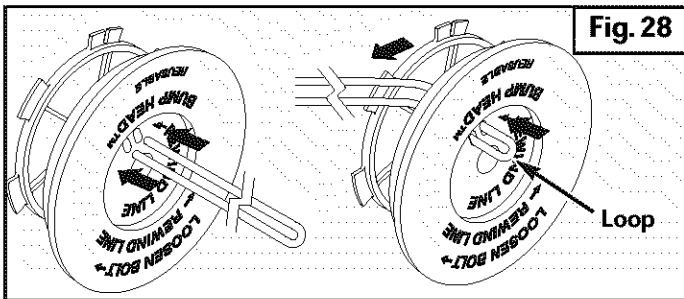

Single Line Installation

Go To Step 8 for SplitLine™ Installation

- Take approximately 40 feet (12.2 m) of new trimming line, loop it into two equal lengths. Insert each end of the line through one of the two holes in the inner reel (Fig. 28). Pull the line through the inner reel so that the loop is as small as possible.
- Wind the lines in tight even layers, onto the reel (Fig. 29). Wind the line in the direction indicated on the inner reel. Place your index finger between the two lines to stop the lines from overlapping. Do not overlap the ends of the line. Proceed to step 11.

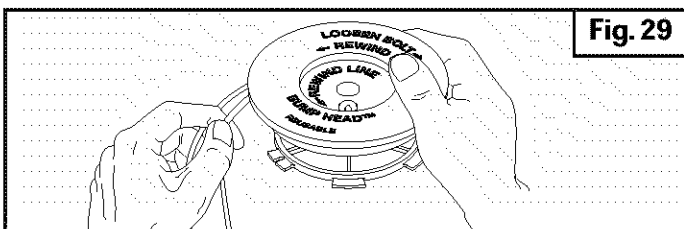

SplitLine™ Installation

- Take approximately 20 feet (6.1 m) of new trimming line. Insert one end of the line through one of the two holes in the inner reel (Fig. 30). Pull the line through the inner reel until only about 4 inches is left out.

- Insert the end of the line into the open hole in the inner reel and pull the line tight to make the loop as small as possible (Fig. 30).
- Before winding, split the line back about 6 inches.
- Wind the line in tight even layers in the direction indicated on the inner reel.

NOTE: Failure to wind the line in the direction indicated will cause the cutting attachment to operate incorrectly.

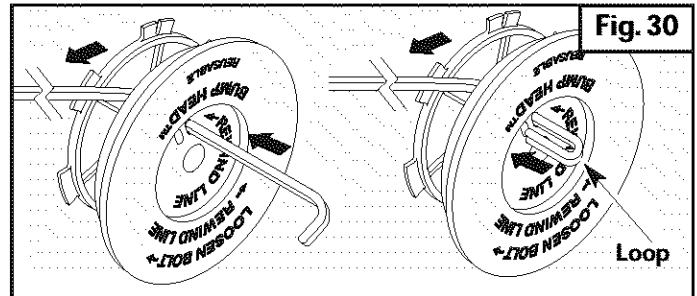

- Insert the ends of the line into the two holding slots (Fig. 31).
- Insert the ends of the line through the eyelets in the outer spool and place inner reel with spring inside the outer spool (Fig. 32). Push the inner reel and outer spool together. While holding the inner reel and outer spool, grasp the ends and pull firmly to release the line from the holding slots in the reel.

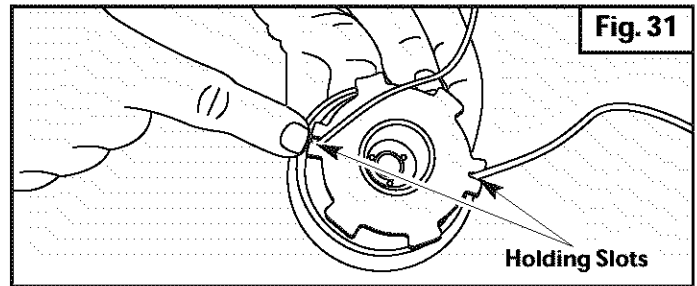

NOTE: The spring must be assembled on the inner reel before reassembling the cutting attachment.

- Hold the inner reel in place and install the bump knob by turning counterclockwise. Tighten securely.

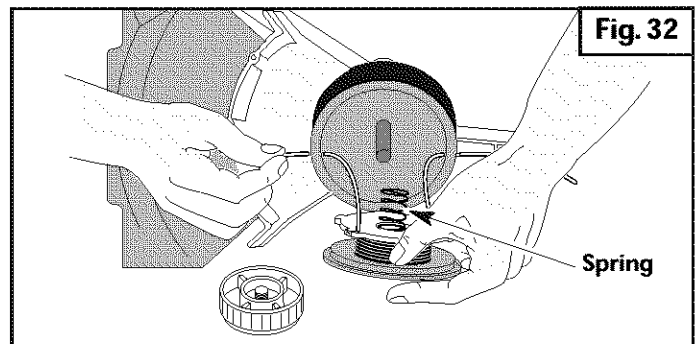

MAINTENANCE & REPAIR INSTRUCTIONS

INSTALLING A PREWOUND REEL

1. Hold the outer spool with one hand and unscrew the bump knob clockwise (Fig. 24). Inspect the bolt inside the bump knob to make sure it moves freely. Replace the bump knob if damaged.
2. Remove the old inner reel from the outer spool (Fig. 24).
3. Remove the spring from the old inner reel (Fig. 24).
4. Place the spring in the new inner reel.

NOTE: The spring must be assembled on the inner reel before reassembling the cutting attachment.

5. Insert the ends of the line through the eyelets in the outer spool (Fig. 32).
6. Place the new inner reel inside the outer spool. Push the inner reel and outer spool together. While holding the inner reel and outer spool, grasp the ends and pull firmly to release the line from the holding slots in the spool.
7. Hold the inner reel in place and install the bump knob by turning counterclockwise. Tighten securely.

Replacement Parts

See *Accessories / Replacement Parts*.

AIR FILTER MAINTENANCE

Removing the Air Filter/Muffler Cover



WARNING: To avoid serious personal injury, always turn your trimmer off and allow it to cool before you clean or service it.

1. Place the choke lever in the **PARTIAL** choke position (B).

NOTE: The choke lever must be in the **PARTIAL** choke position (B) (Fig. 33) to remove the air filter/muffler cover.

2. Remove the four (4) screws securing the air filter/muffler cover (Fig. 33). Use a flat blade or T20 Torx bit screwdriver.
3. Pull the cover from the engine. Do not force.

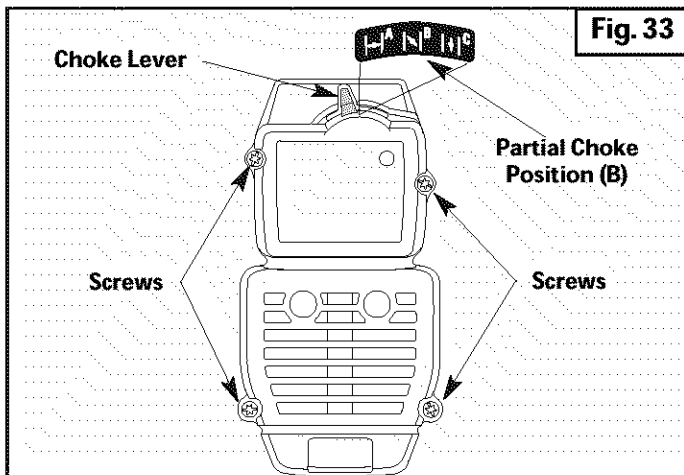

Cleaning the Air Filter

Clean and re-oil the air filter every 10 hours of operation. It is an important item to maintain. Failure to maintain the air filter will VOID the warranty.

1. Remove air filter/muffler cover. Refer to *Removing the Air Filter/Muffler Cover*.
2. Turn cover over and look inside to locate the air filter. Remove the air filter from inside the air filter/muffler cover (Fig. 34).
3. Wash the filter in detergent and water (Fig. 34). Rinse the filter thoroughly. Squeeze out excess water. Allow it to dry completely.
4. Apply enough clean SAE 30 oil to lightly coat the filter (Fig. 35).
5. Squeeze the filter to spread and remove excess oil (Fig. 35).

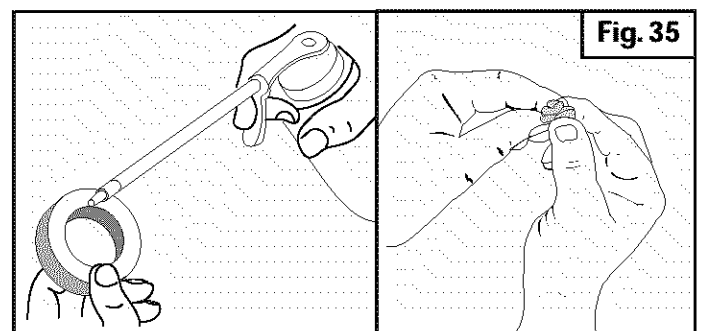
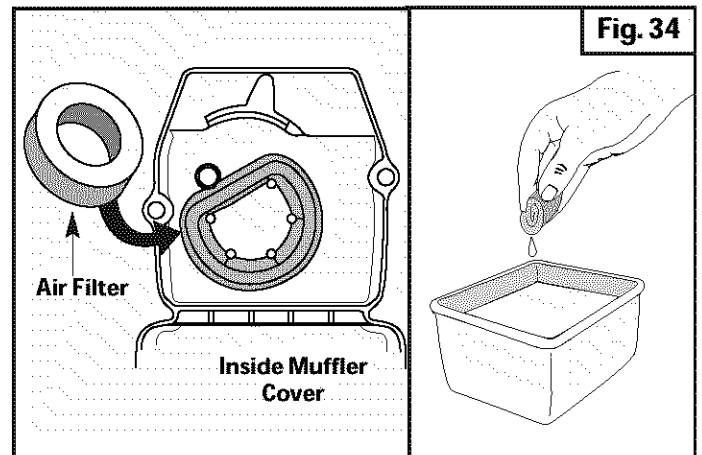

6. Replace the air filter inside the air filter/muffler cover (Fig. 34).

NOTE: Operating the unit without the air filter and air filter/muffler cover assembly will VOID the warranty.

MAINTENANCE & REPAIR INSTRUCTIONS

Reinstalling the Air Filter/Muffler Cover

1. Place the air filter/muffler cover over the back of the carburetor and muffler. Align the screw holes.
2. Insert the four (4) screws into the holes in the air filter/muffler cover (Fig. 33) and tighten.
Do not over tighten.

SPARK ARRESTOR MAINTENANCE

1. Remove air filter/muffler cover. Refer to *Removing the Air Filter/Muffler Cover*.
2. Locate muffler front and the two (2) bolts securing it to the engine (Fig. 36). Remove the two (2) bolts using a flatblade screwdriver or 5/16-inch socket or nut driver. Pull muffler off of the engine.
3. Turn muffler over to the back side and locate the exhaust gasket. Remove the muffler gasket from the muffler (Fig. 36).

NOTE: If the exhaust gasket is torn or damaged, replace it with a new gasket before reassembling muffler.

4. Using a small flatblade screwdriver, carefully pry up the spark arrestor from the recessed hole (Fig. 37). Remove the spark arrestor from the muffler.
5. Clean the spark arrestor with a wire brush. Replace it if it is damaged or if it is impossible to clean thoroughly (Fig. 37).
6. Reinstall the spark arrestor by pressing it into the recessed hole on the muffler's back side. Make sure it fits tightly against the muffler and is not raised up.
7. Place the exhaust gasket against muffler's back side. Align the gasket bolt holes with the bolt holes in the muffler. While holding exhaust gasket in place, insert the bolts into the muffler's front side (Fig. 36).
8. Place the muffler (with the exhaust gasket in place and bolts inserted), against the engine, aligning the bolt holes. Tighten the bolts to secure the muffler to the engine.

If using a torque wrench, torque to:
80-90 in.·lb. (9-10.2 N·m)

9. Reinstall the air filter/muffler cover.

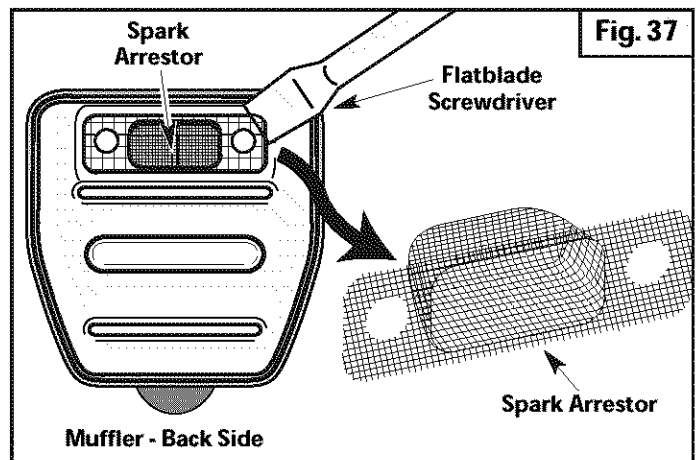
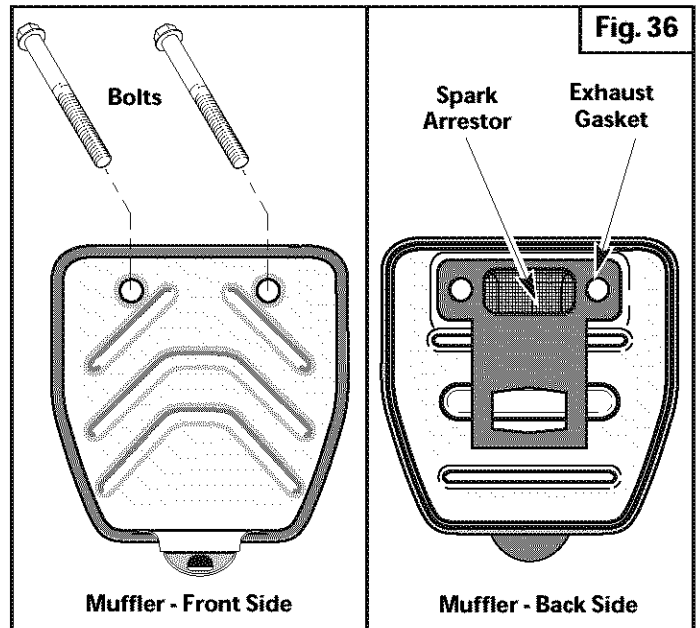

WARNING: If the muffler is not tightened securely, it could fall off causing damage to the unit and possible serious personal injury

MAINTENANCE & REPAIR INSTRUCTIONS

CARBURETOR ADJUSTMENT

The idle speed of the engine is adjustable through the air filter/muffler cover (Fig. 38).

NOTE: Careless adjustments can seriously damage your unit. An authorized service dealer should make carburetor adjustments.

Check Fuel Mixture

Old and/or improperly mixed fuel is usually the reason for improper unit performance. Drain and refill the tank with fresh, properly-mixed fuel prior to making any adjustments. Refer to *Oil and Fuel Information*.

Clean Air Filter

The condition of the air filter is important to the operation of the unit. A dirty air filter will restrict air flow and change the air/fuel mixture. This is often mistaken for an out of adjustment carburetor. Check the condition of the air filter before adjusting the idle speed screw. Refer to *Air Filter Maintenance*.

Adjust Idle Speed Screw

If, after checking the fuel mixture and cleaning the air filter, the engine still will not idle, adjust the idle speed screw as follows:

-  **WARNING:** The cutting attachment may be spinning during idle speed adjustments. Wear protective clothing and observe all safety instructions to prevent serious personal injury.
1. Start the engine and let it run at a high idle for a minute to warm up. Refer to *Starting/Stopping Instructions*.
 2. Release the throttle trigger and let the engine idle. If the engine stops, insert a small Phillips or flat blade screwdriver into the hole in the air filter/muffler cover (Fig. 38). Turn the idle speed screw in, **clockwise**, 1/8 of a turn at a time (as needed) until the engine idles smoothly.

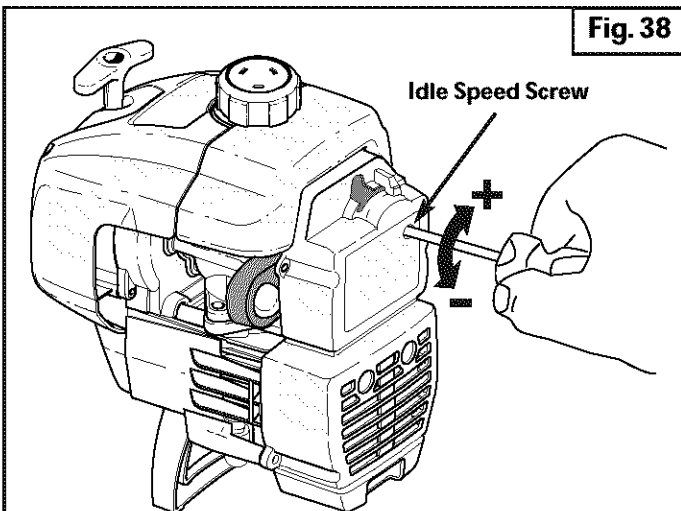

NOTE: The cutting attachment should not rotate when the engine idles.

3. If the cutting attachment rotates when the engine idles, turn the idle speed screw **counterclockwise** 1/8 of a turn at a time (as needed), to reduce idle speed.

Checking the fuel mixture, cleaning the air filter, and adjusting the idle speed should solve most engine problems. If not and all of the following are true:

- the engine will not idle
- the engine hesitates or stalls on acceleration
- there is a loss of engine power

Have the carburetor adjusted by an authorized service dealer.



WARNING: To prevent serious personal injury, make sure the cutting attachment has stopped rotating before you turn it off and set it down.

REPLACING THE SPARK PLUG

Use a Champion RDJ7Y spark plug, or equivalent. The correct air gap is **0.020 inch (0.5 mm)**. Remove the plug after every 25 hours of operation and check its condition.

1. Stop the engine and allow it to cool. Grasp the plug wire firmly and pull it from the spark plug.
2. Clean around the spark plug. Remove the spark plug from the cylinder head by turning a 5/8-inch socket counterclockwise.
3. Replace a cracked, fouled or dirty spark plug. Set the air gap at **0.020 in. (0.5 mm)** using a feeler gauge (Fig. 39).



CAUTION: Do not sand blast, scrape or clean electrodes. Grit in the engine could damage the cylinder.

4. Install a correctly-gapped spark plug in the cylinder head. Tighten by turning the 5/8-inch socket clockwise until snug.

If using a torque wrench torque to:

110-120 in.·lb. (12.3-13.5 N·m)

Do not over tighten.

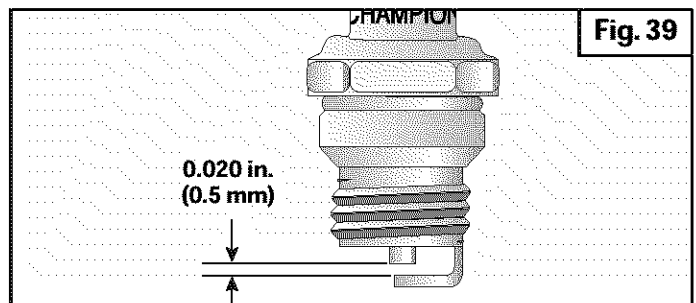

MAINTENANCE & REPAIR INSTRUCTIONS

CLEANING



WARNING: To avoid serious personal injury, always turn your trimmer off and allow it to cool before you clean or service it.

Use a small brush to clean off the outside of the unit. Do not use strong detergents. Household cleaners that contain aromatic oils such as pine and lemon, and solvents such as kerosene, can damage plastic housing or handle. Wipe off any moisture with a soft cloth.

STORAGE

- Never store a fueled unit where fumes may reach an open flame or spark.
- Allow the engine to cool before storing.
- Store the unit locked up to prevent unauthorized use or damage.
- Store the unit in a dry, well-ventilated area.
- Store the unit out of the reach of children.

LONG TERM STORAGE

If you plan on storing the unit for an extended time, use the following storage procedure:

1. Drain all fuel from the fuel tank into a container with the same 2-cycle fuel mixture. Do not use fuel that has been stored for more than 60 days. Dispose of the old fuel/oil mix in accordance to Federal, State and Local regulations.
2. Start the engine and allow it to run until it stalls. This ensures that all fuel has been drained from the carburetor.
3. Allow the engine to cool. Remove the spark plug and put 1 oz. (30 ml) of any high quality motor oil or 2-cycle oil into the cylinder. Pull the starter rope slowly to distribute the oil. Reinstall the spark plug.

NOTE: Remove the spark plug and drain all of the oil from the cylinder before attempting to start the trimmer after storage.

4. Thoroughly clean the unit and inspect it for any loose or damaged parts. Repair or replace damaged parts and tighten loose screws, nuts or bolts. The unit is ready for storage.

TRANSPORTING

- Allow the engine to cool before transporting.
- Drain fuel from unit.
- Tighten fuel cap before transporting.
- Secure the unit while transporting.

ACCESSORIES/REPLACEMENT PARTS

2-Cycle Oil	147543
Spark Plug	610311
Spark Arrestor	182747
Replacement Line	180120
Replacement Line Cartridge	147345
Inner Reel Spring	610636
Outer Spool	683301
Inner Reel	147495
Bump Knob	180814
Fuel Cap	180000
Shoulder Strap	682075

These replacement parts can be purchased from your local authorized dealer.

TROUBLESHOOTING

ENGINE WILL NOT START

CAUSE

On/Off Stop Control is in OFF position
Empty fuel tank
Primer bulb wasn't pressed enough
Engine is flooded
Old or improperly mixed fuel
Fouled spark plug
Plugged spark arrestor

ACTION

Turn On/Off Stop Control to ON
Fill fuel tank with properly mixed fuel
Press primer bulb fully and slowly 10 times
Use starting procedure with choke lever in RUN
Drain gas tank and add fresh fuel mixture
Replace or clean the spark plug
Clean or replace spark arrestor

ENGINE WILL NOT IDLE

CAUSE

Air filter is plugged
Old or improperly mixed fuel
Improper carburetor adjustment

ACTION

Replace or clean the air filter
Drain gas tank and add fresh fuel mixture
Adjust according to the *Carburetor Adjustments* section

ENGINE WILL NOT ACCELERATE

CAUSE

Old or improperly mixed fuel
Improper carburetor adjustment
Cutting attachment bound with grass
Dirty air filter
Plugged spark arrestor

ACTION

Drain gas tank and add fresh fuel mixture
Take to an authorized service dealer for an adjustment
Stop the engine and clean the cutting attachment
Clean or replace the air filter
Clean or replace spark arrestor

ENGINE LACKS POWER OR STALLS WHEN CUTTING

CAUSE

Old or improperly mixed fuel
Improper carburetor adjustment
Fouled spark plug
Plugged spark arrestor

ACTION

Drain gas tank and add fresh fuel mixture
Take to an authorized service dealer for an adjustment
Replace or clean the spark plug
Clean or replace spark arrestor

CUTTING ATTACHMENT WILL NOT ADVANCE LINE

CAUSE

Cutting attachment bound with grass
Cutting attachment out of line
Inner reel bound up
Cutting head dirty
Line welded
Line twisted when refilled
Not enough line is exposed

ACTION

Stop the engine and clean cutting attachment
Refill with new line
Replace the inner reel
Clean inner reel and outer spool
Disassemble, remove the welded section and rewind
Disassemble and rewind the line
Push the bump knob and pull out line until 4 inches (102 mm) of line is outside of the cutting attachment

CUTTING LINE ADVANCES UNCONTROLLABLY

CAUSE

Oil, cleaner or lubricant in cutting head

ACTION

Clean and thoroughly dry the cutting head

If further assistance is required, contact your authorized service dealer.

SPECIFICATIONS

ENGINE

Engine Type.....	Air-Cooled, 2-Cycle
Stroke.....	1.25 in. (31.75 mm)
Displacement.....	1.9 cu in. (31 cc)
Clutch Type.....	Centrifugal
Idle Speed RPM.....	2,800 - 4,400 rpm
Operating RPM.....	7,200+ rpm
Ignition Type.....	Electronic
Ignition Switch.....	Rocker Switch
Spark Plug Gap.....	0.020 in. (0.5 mm)
Lubrication.....	Fuel/Oil Mixture
Fuel/Oil Ratio.....	40:1
Carburetor.....	Diaphragm, All-Position
Starter.....	Auto Rewind
Muffler.....	Baffled with Guard
Throttle.....	Manual Spring Return
Fuel Tank Capacity.....	12 oz. (355 ml)

DRIVE SHAFT and CUTTING ATTACHMENT

Drive Shaft Housing.....	Steel Tube
Throttle Control.....	Finger-Tip Trigger with Lock-Out
Unit Weight (No fuel, with cutting attachment, cutting attachment shield and J-handle).....	14.75 lbs. (6.69 kg)
Cutting Mechanism.....	4-Tooth Cutting Blade, Dual String Cutting Head
Line Spool.....	Bump Line Releaser
Line Spool Diameter.....	4 inches (101.6 mm)
Trimming Line Diameter.....	0.095 inch (2.41 mm)
Cutting Path Diameter, Cutting Attachment.....	18 inches (45.7 cm)
Cutting Path Diameter, Cutting Blade.....	8 inches (204 mm)
Shoulder Harness.....	Single Quick-Snap

NOTES

NOTES

NOTES

EPA Emission Control Warranty Statement

Your Warranty Rights and Obligations

The Environmental Protection Agency and Troy-Bilt LLC are pleased to explain the emission control system warranty on your 2002 and later small off-road engine. New small off-road engines must be designed, built and equipped to meet stringent anti-smog standards. Bolens must warrant the emission control system on your small off-road engine for the periods of time listed below provided there has been no abuse, neglect or improper maintenance of your small off-road engine.

Your emission control system may include parts such as the carburetor or fuel-injected system, the ignition system, and catalytic converter. Also included may be hoses, belts, connectors and other emission-related assemblies.

Where a warrantable condition exists, Bolens will repair your small off-road engine at no cost to you including diagnosis, parts and labor.

The 2002 and later small off-road engines are warranted for two years. If any emission-related part on your engine is defective, the part will be repaired or replaced by Bolens.

Owners Warranty Responsibilities

- As the small off-road engine owner, you are responsible for the performance of the required maintenance listed in your operator's manual. Bolens recommends that you retain all receipts covering maintenance on your small off-road engine, but Bolens cannot deny warranty solely for the lack of receipts or for your failure to ensure the performance of all scheduled maintenance.
- As the small off-road engine owner, you however should be aware that Bolens may deny you warranty coverage if your small off-road engine or a part has failed due to abuse, neglect, improper maintenance or unapproved modifications.
- You are responsible for presenting your small off-road engine to a Bolens Authorized Service Center as soon as a problem exists. The warranty repairs should be completed in a reasonable amount of time, not to exceed 30 days.

If you have any questions regarding your warranty rights and responsibilities, you should call 1-800-520-5520.

Manufacturer's Warranty Coverage

- The warranty period begins on the date the engine or equipment is delivered to the retail purchaser.
- The manufacturer warrants to the initial owner and each subsequent purchaser, that the engine is free from defects in material and workmanship which cause the failure of a warranted part for a period of two years.
- Repair or replacement of warranted part will be performed at no charge to the owner at an Authorized Bolens Service Center. For the nearest location please contact Bolens at: 1-800-520-5520.
- Any warranted part which is not scheduled for replacement, as required maintenance or which is scheduled for only for regular inspection to the effect of "Repair or Replace as Necessary" is warranted for the warranty period. Any warranted part which is scheduled for replacement as required maintenance will be warranted for the period of time up to the first scheduled replacement point for that part.
- The owner will not be charged for diagnostic labor which leads to the determination that a warranted part is defective, if the diagnostic work is performed at an Authorized Bolens Service Center.
- The manufacturer is liable for damages to other engine components caused by the failure of a warranted part still under warranty.
- Failures caused by abuse, neglect or improper maintenance are not covered under warranty.
- The use of add-on or modified parts can be grounds for disallowing a warranty claim. The manufacturer is not liable to cover failures of warranted parts caused by the use of add-on or modified parts.
- In order to file a claim, go to your nearest Authorized Bolens Service Center. Warranty services or repairs will be provided at all Authorized Bolens Service Centers.
- Any manufacturer approved replacement part may be used in the performance of any warranty maintenance or repair of emission related parts and will be provided without charge to the owner. Any replacement part that is equivalent in performance or durability may be used in non-warranty maintenance or repair and will not reduce the warranty obligations of the manufacturer.
- The following components are included in the emission related warranty of the engine, air filter, carburetor, primer, fuel lines, fuel pick up/ fuel filter, ignition module, spark plug and muffler.

PARTS LIST

ENGINE PARTS - MODEL BL250 2-CYCLE GAS TRIMMER PPN 41BD250G163

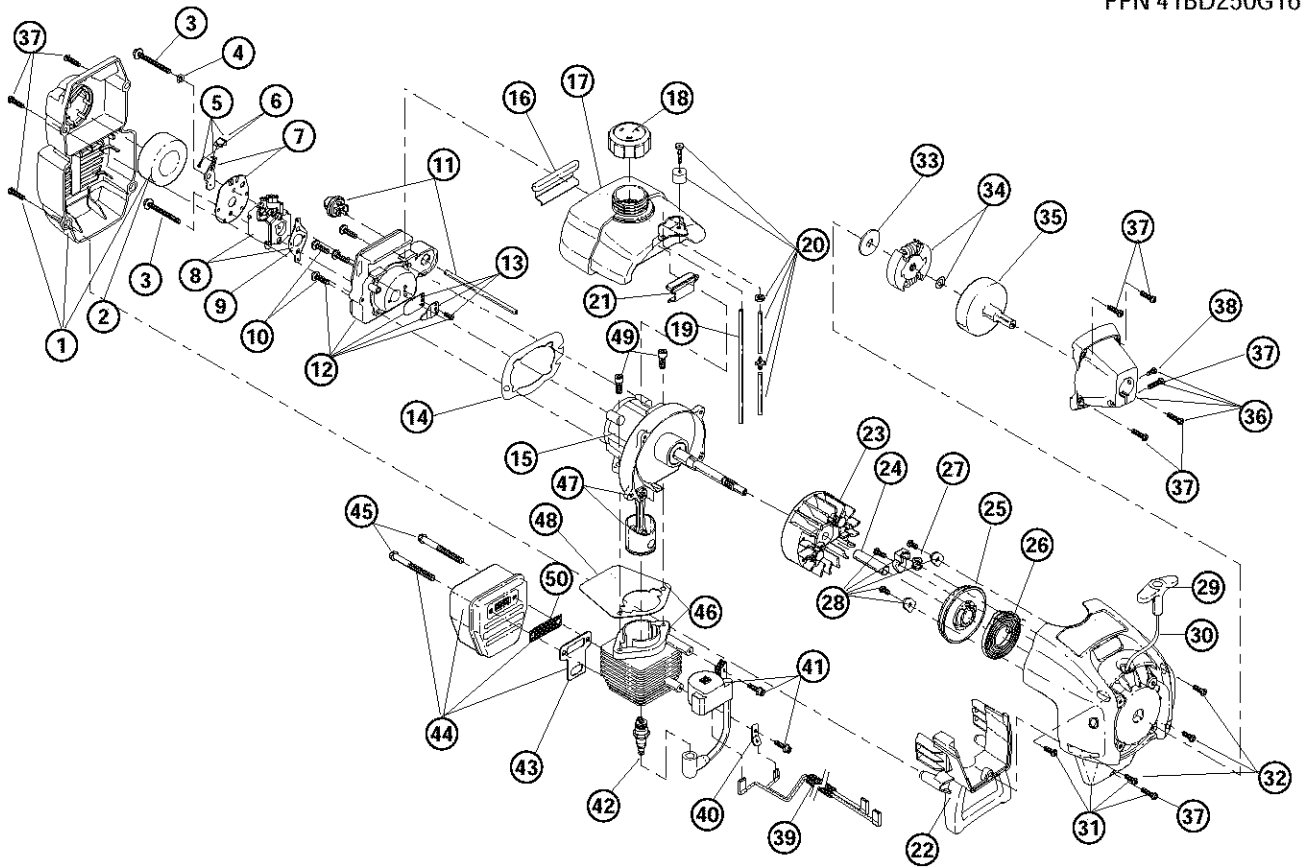

Item	Part No.	Description	Item	Part No.	Description
1	791-182059	Air Cleaner/Muffler Cover Assembly (includes 2 & 37)	30	791-613103	Rope
2	791-180350	Air Cleaner Filter	31	753-04253	Starter Housing Assembly (includes 25-29 & 31)
3	791-180351	Carburetor Mounting Screws	32	791-181862	Housing Screw
4	791-180226	Wavey Washer	33	791-182368	Clutch Washer
5	791-182160	Choke Lever Assembly (includes 6)	34	791-181445	Clutch Rotor Assembly (includes 33)
6	791-182161	Choke Knob and Screw	35	791-153592	Clutch Drum Assembly
7	791-182162	Choke Lever and Plate (includes 4 & 5)	36	791-182797	Clutch Cover Assembly
8	753-04333	Carburetor Assembly (includes 9 & 20)	37	791-181345	Cover Screw
9	791-610675	Carburetor Gasket	38	791-182519	Anti-Rotation Screw
10	791-181860	Carb Mount Screw	39	791-182798	Wire Leads and Sleeve
11	791-683974	Primer and Hose Assembly	40	791-611063	Ground Tab
12	753-1196	Carb Mount Assembly (includes 10, 13 & 14)	41	753-04337	Module Assembly (includes 40)
13	791-684451	Reed Assembly	42	791-610311	Spark Plug
14	753-1208	Carburetor Mount Gasket	43	753-04159	Exhaust Gasket
15	753-04332	Crank Case Service Assembly (includes 10)	44	791-182066	Muffler Assembly (includes 43, 45 & 50)
16	791-612134	Rear Mounting Pad	45	791-147575	Muffler Mounting Bolt Assembly
17	753-04311	Fuel Tank Assembly (includes 18-20)	46	753-04323	Cylinder Assembly (includes 50)
18	791-182612	Fuel Cap Assembly	47	753-1207	Piston and Rod Assembly
19	791-181168	Fuel Return Line	48	753-1197	Cylinder Gasket
20	791-682039	Fuel Line Assembly	49	791-182723	Cylinder Bolt
21	791-145308	Front Mounting Pad	50	791-182747	Spark Arrestor Screen
22	791-182064	Shroud Extension and Stand	*	753-04134	Engine Gasket Kit
23	791-182736	Flywheel Assembly	*	791-180090	O.E.M. Carburetor Repair Kit
24	791-181065	Spacer	*	791-180091	Gasket Diaphragm Repair Kit
25	753-04232	Recoil Pulley Assembly	*	753-1209	Piston Ring
26	791-613102	Recoil Spring	*	753-04334	Short Block Assembly (includes 10, 15, 42, 47-50)
27	791-611061	Rope Guide	*	791-181599	Clutch Springs (Qty. 2)
28	791-181441	Pulley Retainer Assembly			
29	791-181079	Pull Handle			
			*		Items Not Shown

PARTS LIST

BOOM AND TRIMMER PARTS - MODEL BL250

2-CYCLE GAS TRIMMER

PPN 41BD250G163

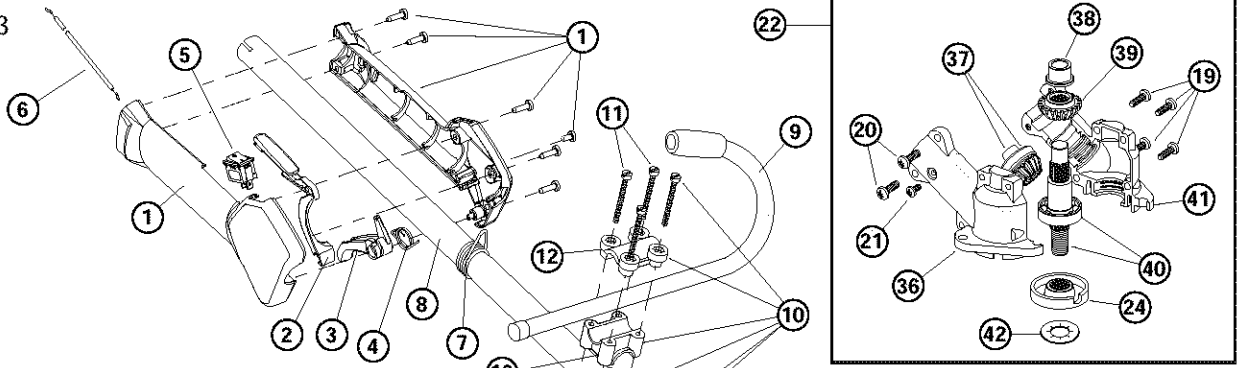

Item	Part No.	Description
1	791-00040	Throttle Housing and Trigger Assembly (includes 2-4)
2	791-00041	Throttle Trigger Lock-Out
3	791-00042	Throttle Trigger
4	791-182690	Throttle Trigger Spring
5	791-182405	Switch Assembly
6	791-182877	Throttle Cable Assembly
7	791-610327	Harness Clip
8	791-147486	Drive Shaft Housing Assembly
9	791-180286	J-Handle Assembly
10	791-683295	Handle Bracket Assembly (includes 11-16)
11	791-181811	Screw
12	791-181812	Upper Handle Clamp
13	791-181813	Middle Handle Clamp
14	791-181814	Lower Handle Clamp
15	791-181815	Nut
16	791-145569	Anti-Rotation Screw
17	791-683299	Shield and Blade Assembly (includes 18)
18	791-682061	Blade Assembly
19	791-182200	Shield Mount Screw Assembly
20	791-182195	Gearbox Mounting Hardware
21	791-145569	Anti-Rotation Screw
22	791-182193	Gearbox Assembly (includes 20, 21, 24 & 25)
23	791-147492	Blade Shield
24	791-182196	Blade Driver
25	791-147490	Retaining Washer
26	791-612483	Spool Shaft
27	791-683301	Outer Spool and Eyelet Assembly
28	791-612026	Retainer
29	791-610636	Spring
30	791-147495	Inner Reel
31	791-180814	Bump Head Knob Assembly
32	791-145873	4-Tooth Blade
33	791-683304	Guard Mount Screws
34	791-181699	Nut
35	791-181817	Flexible Drive Shaft
36	791-182192	Right Housing
37	791-182194	Pinion Gear Assembly
38	791-182199	Output Shaft Bushing
39	791-182198	Output Shaft Gear
40	791-182197	Output Shaft Assembly (includes 38 & 39)
41	791-182191	Left Housing
42	753-04348	Palnut
*	791-180014	Blade Retaining Kit (includes 25 & 34)
*	791-613226	Locking Rod Tool
*	791-682075	Shoulder Harness

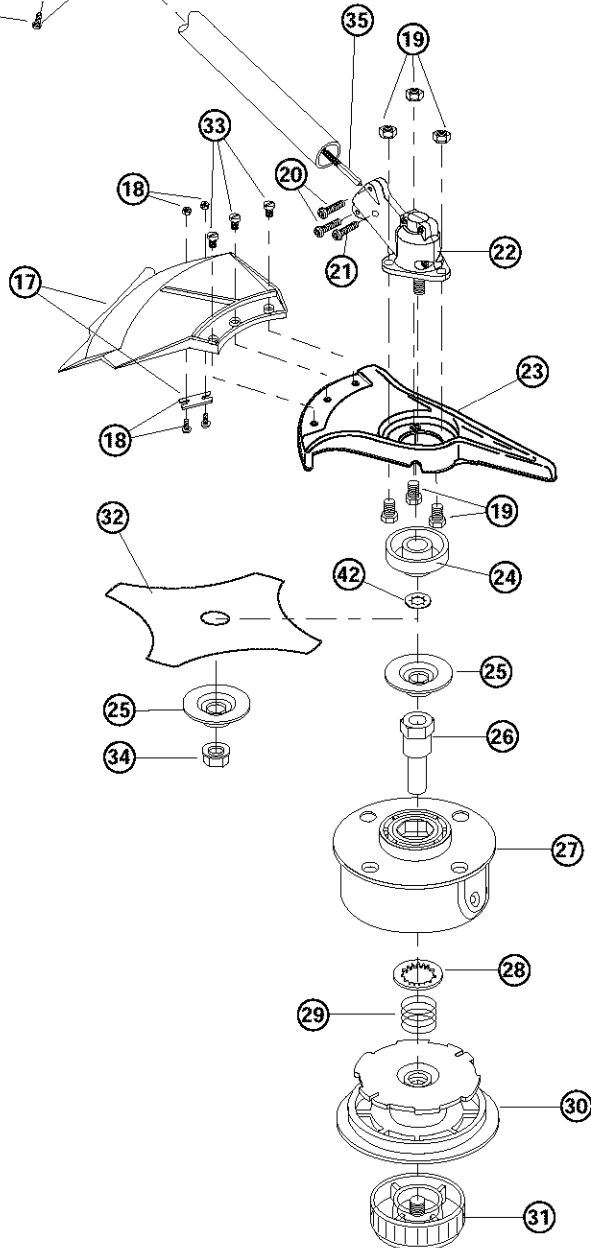

Optional Accessories

- * 791-147278B Reel and Line Assembly
- * 791-147498 Bump Head Assembly (includes 26-31)
- * Items Not Shown

MANUFACTURER'S LIMITED WARRANTY FOR:

Bolens

SINCE-1850

The limited warranty set forth below is given by Troy-Bilt LLC with respect with new merchandise purchased and used in the United States, its possessions and territories.

Troy-Bilt warrants this product against defects in material and workmanship for a period of two (2) years commencing on the date of original purchase and will, at its option, repair or replace, free of charge, any part found to be defective in material or workmanship. This limited warranty shall only apply if this product has been operated and maintained in accordance with the Operator's Manual furnished with the product, and has not been subject to misuse, abuse, commercial use, neglect, accident, improper maintenance, alteration, vandalism, theft, fire, water or damage because of other peril or natural disaster. Damage resulting from the installation or use of any accessory or attachment not approved by Troy-Bilt for use with the product(s) covered by this manual will void your warranty as to any resulting damage.

This warranty is limited to ninety (90) days from the date of original retail purchase for any Bolens product that is used for rental or commercial purposes, or any other income-producing purpose.

HOW TO OBTAIN SERVICE: Warranty service is available, WITH PROOF OF PURCHASE THROUGH YOUR LOCAL AUTHORIZED SERVICE DEALER. To locate the dealer in your area, please check for a listing in the Yellow Pages or contact the Customer Service Department of Troy-Bilt LLC by calling 1-800-520-5520 or writing to PO Box 361131, Cleveland, Ohio 44136-0019. No product returned directly to the factory will be accepted unless prior written permission has been extended by the Customer Service Department of Troy-Bilt LLC.

This limited warranty does not provide coverage in the following cases:

- A. Tune-ups - Spark Plugs, Carburetor Adjustments, Filters
- B. Wear items - Bump Knobs, Outer Spools, Cutting Line, Inner Reels, Starter Pulley, Starter Ropes, Drive Belts
- C. Troy-Bilt does not extend any warranty for products sold or exported outside of the United States of America, its possessions and territories, except those sold through Troy-Bilt's authorized channels of export distribution.

Troy-Bilt reserves the right to change or improve the design of any Bolens Product without assuming any obligation to modify any product previously manufactured.

No implied warranty, including any implied warranty of merchantability or fitness for a particular purpose, applies after the applicable period of express written warranty above as to the parts as identified. No other express warranty or guaranty, whether written or oral, except as mentioned above, given by any person or entity, including a dealer or retailer, with respect to any product shall bind Troy-Bilt LLC. During the period of the Warranty, the exclusive remedy is repair or replacement of the product as set forth above. (Some states do not allow limitations on how long an implied warranty lasts, so the above limitation may not apply to you.)

The provisions as set forth in this Warranty provide the sole and exclusive remedy arising from the sales. Troy-Bilt LLC shall not be liable for incidental or consequential loss or damages including, without limitation, expenses incurred for substitute or replacement lawn care services, for transportation or for related expenses, or for rental expenses to temporarily replace a warranted product. (Some states do not allow limitations on how long an implied warranty lasts, so the above limitation may not apply to you.)

In no event shall recovery of any kind be greater than the amount of the purchase price of the product sold. Alteration of the safety features of the product shall void this Warranty. You assume the risk and liability for loss, damage, or injury to you and your property and/or to others and their property arising out of the use or misuse or inability to use the product.

This limited warranty shall not extend to anyone other than the original purchaser, original lessee or the person for whom it was purchased as a gift.

How State Law Relates to this Warranty: This warranty gives you specific legal rights, and you may also have other rights which vary from state to state.

To locate your nearest service dealer dial 1-800-520-5520.

TROY-BILT LLC

PO Box 361131

Cleveland, OH 44136-0019 U.S.A.

**SAVE THESE INSTRUCTIONS FOR FUTURE REFERENCE
FOR QUESTIONS CALL 1-800-520-5520**