

Operating Instructions

Please read and save these instructions. Read carefully before attempting to assemble, install, operate or maintain the product described. Protect yourself and others by observing all safety information. Failure to comply with instructions could result in personal injury and/or property damage! Retain instructions for future reference.

Air Compressors

Description

Air compressor units are intended to provide compressed air to power pneumatic tools, operate spray guns and supply air for pneumatic valves and actuators. The pumps supplied with these units have oil lubricated bearings. A small amount of oil carryover is present in the compressed air stream.

Applications requiring air free of oil vapor should have the appropriate filter installed. The air compressor units are to be mounted per the instructions provided on a solid floor. Any other use of these units will void the warranty and the manufacturer will not be responsible for problems or damages resulting from such misuse. Refer to the enclosed "Replacement Parts Manual" to identify compressor as single stage or two-stage.

Safety Guidelines

This manual contains information that is very important to know and understand. This information is provided for SAFETY and to PREVENT EQUIPMENT PROBLEMS. To help recognize this information, observe the following symbols.

⚠ DANGER *Danger indicates an imminently hazardous situation which, if not avoided, will result in death or serious injury.*

⚠ WARNING *Warning indicates a potentially hazardous situation which, if not avoided, could result in death or serious injury.*

⚠ CAUTION *Caution indicates a potentially hazardous situation which, if not avoided, MAY result in minor or moderate injury.*

NOTICE *Notice indicates important informa-*

tion, that if not followed, may cause damage to equipment.

Unpacking

After unpacking the unit, inspect carefully for any damage that may have occurred during transit. Make sure to tighten fittings, bolts, etc., before putting unit into service.

⚠ WARNING *Do not operate unit if damaged during shipping, handling or use. Damage may result in bursting and cause injury or property damage.*

General Safety

Since the air compressor and other components (material pump, spray guns, filters, lubricators, hoses, etc.) used make up a high pressure pumping system, the following safety precautions must be observed at all times:

1. Read all manuals included with this product carefully. Be thoroughly familiar with the controls and the proper use of the equipment.
2. Follow all local electrical and safety codes as well as the United States National Electrical Codes (NEC) and Occupational Safety and Health Act (OSHA).
3. Only persons well acquainted with these rules of safe operation should be allowed to use the compressor.
4. Keep visitors away and NEVER allow children in the work area.
5. Wear safety glasses and use hearing protection when operating the unit.



⚠ DANGER

Breathable Air Warning

This compressor/pump is NOT equipped and should NOT be used "as is" to supply breathing quality air. For any application of air for human consumption, you must fit the air compressor/pump with suitable in-line safety and alarm equipment. This additional equipment is necessary to properly filter and purify the air to meet minimal specifications for Grade D breathing as described in Compressed Gas Association Commodity Specification G 7.1 - 1966, OSHA 29 CFR 1910. 134, and/or Canadian Standards Associations (CSA).

DISCLAIMER OF WARRANTIES

In the event the compressor is used for the purpose of breathing air application and proper in-line safety and alarm equipment is not simultaneously used, existing warranties are void, and the company disclaims any liability whatsoever for any loss, personal injury or damage.

6. Do not stand on or use the unit as a handhold.
7. Before each use, inspect compressed air system and electrical components for signs of damage, deterioration, weakness or leakage. Repair or replace defective items before using.
8. Check all fasteners at frequent intervals for proper tightness.

REMINDER: Keep your dated proof of purchase for warranty purposes! Attach it to this manual or file it for safekeeping.

Air Compressors

General Safety (Cont.)

⚠WARNING

Motors, electrical equipment and controls can cause electrical arcs that will ignite a flammable gas or vapor. Never operate or repair in or near a flammable gas or vapor. Never store flammable liquids or gases in the vicinity of the compressor.



⚠WARNING

Never operate compressor without a beltguard. This unit can start automatically without warning. Personal injury or property damage could occur from contact with moving parts.



9. Do not wear loose clothing or jewelry that will get caught in the moving parts of the unit.

⚠CAUTION

Compressor parts may be hot even if the unit is stopped.



10. Keep fingers away from a running compressor; fast moving and hot parts will cause injury and/or burns.
11. If the equipment should start to vibrate abnormally, STOP the engine/motor and check immediately for the cause. Vibration is generally an indication of trouble.
12. To reduce fire hazard, keep engine/motor exterior free of oil, solvent, or excessive grease.

⚠WARNING

An ASME code safety relief valve with a setting no higher than the Maximum Allowable Working Pressure (MAWP) of the tank MUST be installed in the air lines or in the tank for this compressor. The ASME safety valve must have sufficient flow and pressure ratings to protect the pressurized components from bursting. The flow rating can be found in the parts manual. The safety valve in the intercooler does not provide system protection.

⚠CAUTION

Maximum operating pressure is 175 psi for two-stage compressors and 135 - 150 psi for single stage compressors. Do not operate with pressure switch or pilot valves set higher than 175 psi (two-stage) or 135 - 150 psi (single stage).

13. Never attempt to adjust ASME safety valve. Keep safety valve free from paint and other accumulations.

⚠DANGER

Never attempt to repair or modify a tank! Welding, drilling or any other modification will weaken the tank resulting in damage from rupture or explosion. Always replace worn, cracked or damaged tanks.



NOTICE

Drain liquid from tank daily.

14. Tanks rust from moisture build-up, which weakens the tank. Make sure to drain tank regularly and inspect periodically for unsafe conditions such as rust formation and corrosion.
15. Fast moving air will stir up dust and debris which may be harmful. Release air slowly when draining moisture or depressurizing the compressor system.

SPRAYING PRECAUTIONS

⚠WARNING

Do not spray flammable materials in vicinity of open flame or near ignition sources including the compressor unit.



16. Do not smoke when spraying paint, insecticides, or other flammable substances.
17. Use a face mask/respirator when spraying and spray in a well ventilated area to prevent health and fire hazards.
18. Do not direct paint or other sprayed material at the compressor. Locate compressor as far away from the spraying area as possible to minimize overspray accumulation on the compressor.
19. When spraying or cleaning with solvents or toxic chemicals, follow the instructions provided by the chemical manufacturer.



Installation

⚠WARNING

Disconnect, tag and lock out power source then release all pressure from the system before attempting to install, service, relocate or perform any maintenance.



⚠CAUTION

Do not lift or move unit without appropriately rated equipment. Be sure the unit is securely attached to lifting device used. Do not lift unit by holding onto tubes or coolers. Do not use unit to lift other attached equipment.

⚠CAUTION

Never use the wood shipping skids for mounting the compressor.

Install and operate unit at least 24" from any obstructions in a clean, well ventilated area. The surrounding air temperature should not exceed 100° F. This will ensure an unobstructed flow of air to cool compressor and allow adequate space for maintenance.

⚠CAUTION

Do not locate the compressor air inlet near steam, paint spray, sandblast areas or any other source of contamination.

NOTE: If compressor operates in a hot, moist environment, supply compressor pump with clean, dry outside air. Supply air should be piped in from external sources.

TANK MOUNTING

The tank should be bolted into a flat, even, concrete floor or on a separate concrete foundation. Vibration isolators should be used between the tank leg and the floor. Model MP345800AJ isolator pads are recommended for horizontal units. Model MP345700AJ isolator pads are recommended for vertical units. When using isolator pads, **do not draw bolts tight**. Allow the pads to absorb vibrations. When isolators are used, a flexible hose or coupling should be installed between the tank and service piping.

⚠WARNING

Failure to properly install the tank can lead to cracks at the welded joints and possible bursting.



PIPING

⚠WARNING

Never use plastic (PVC) pipe for compressed air. Serious injury or death could result.

Any tube, pipe or hose connected to the unit must be able to withstand the temperature generated and retain the pressure. All pressurized components of the air system must have a pressure rating higher than or equal to the 200 psi for

Installation (Cont.)

two-stage compressors or 150 psi for single stage compressors ASME safety valve setting. Incorrect selection and installation of any tube, pipe or hose could result in bursting and injury. Connect piping system to tank using the same size fitting as the discharge port.

INSTALLING A SHUT-OFF VALVE

A shut-off valve should be installed on the discharge port of the tank to control the air flow out of the tank. The valve should be located between the tank and the piping system.

⚠WARNING *Never install a shut-off valve between the compressor pump and the tank. Personal injury and/or equipment damage may occur. Never use reducers in discharge piping.*

When creating a permanently installed system to distribute compressed air, find the total length of the system and select pipe size from the chart. Bury underground lines below the frost line and avoid pockets where condensation can gather and freeze.

Apply air pressure to the piping installa-

tion and make sure all joints are free from leaks BEFORE underground lines are covered. Before putting the compressor into service, find and repair all leaks in the piping, fittings and connections.

MINIMUM PIPE SIZE FOR COMPRESSED AIR LINE

CFM	Length Of Piping System			
	25'	50'	100'	250'
10	1/2"	1/2"	3/4"	3/4"
20	3/4	3/4	3/4	1
40	3/4	1	1	1
60	3/4	1	1	1
100	1	1	1	1 1/4

WIRING

⚠WARNING *All wiring and electrical connections must be performed by a qualified electrician. Installations must be in accordance with local and national codes.*

⚠CAUTION *Overheating, short 3 circuiting and fire damage will result from inadequate wiring.*

Wiring must be installed in accordance with National Electrical Code and local codes and standards that have been set up covering electrical apparatus and wiring. These should be consulted and local ordinances observed. Be certain that adequate wire sizes are used, and that:

1. Service is of adequate ampere rating.
2. The supply line has the same electrical characteristics (voltage, cycles and phase) as the motor.
3. The line wire is the proper size and that no other equipment is operated from the same line. The chart gives minimum recommended wire sizes for compressor installations.

MINIMUM WIRE SIZE USE 75°C COPPER WIRE

HP	Amps	Single Phase		Three Phase
		230V	208/230V	
SPL	up to 22.0	10 AWG		
5.0		8 AWG	12 AWG	14 AWG
7.5		8 AWG	10 AWG	12 AWG
10.0		N/A	8 AWG	12 AWG
15.0		N/A	6 AWG	10 AWG
25.0		N/A	3 AWG	8 AWG

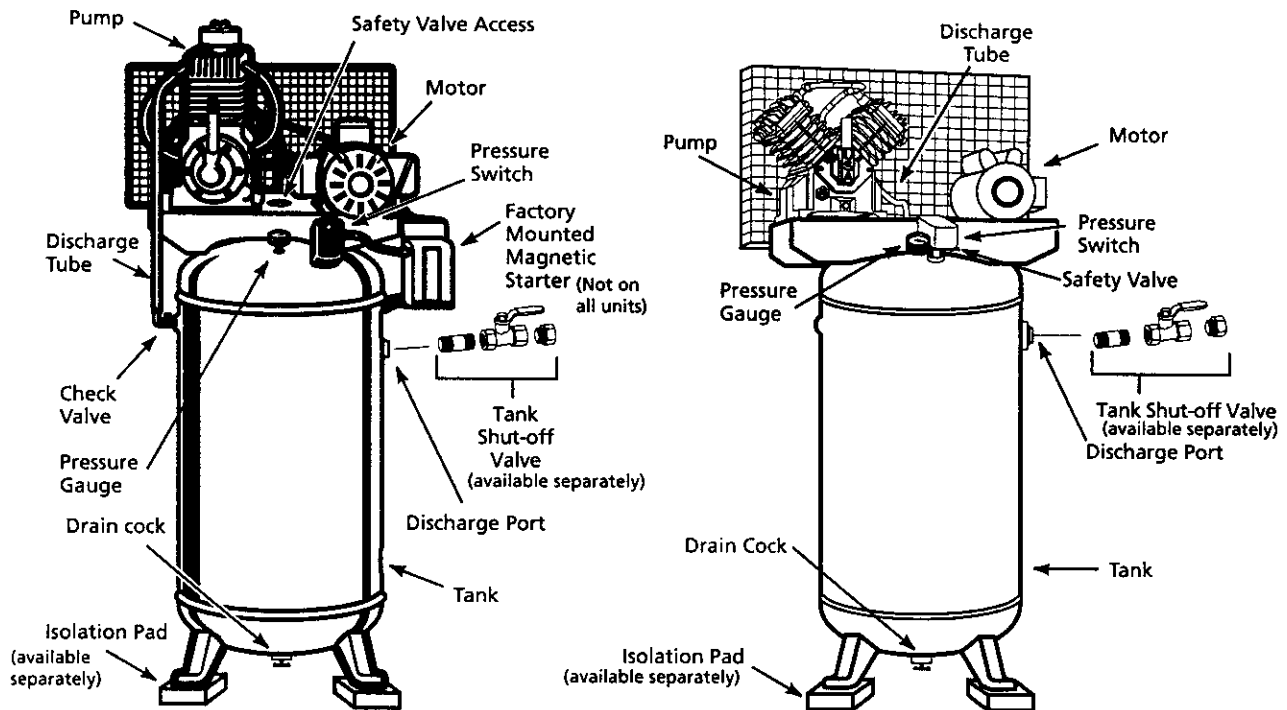

Figure 1 - Typical Vertical Unit Identification

Air Compressors

Installation (Cont.)

Recommended wire sizes may be larger than the minimum set up by local ordinances. If so, the larger size wire should be used to prevent excessive line voltage drop. The additional wire cost is very small compared with the cost of repairing or replacing a motor electrically "starved" by the use of supply wires which are too small.

GROUNDING

⚠ DANGER

Improperly grounded electrical components are shock hazards. Make sure all the components are properly grounded to prevent death or serious injury.



This product **must** be grounded. Grounding reduces the risk of electrical shock by providing an escape wire for the electric current if short circuit occurs. This product must be installed and operated with a power cord or cable that has a grounding wire.

MOTOR HOOKUP AND STARTER INSTALLATION

Branch circuit protection must be provided as specified in the United States National Electrical Code, Chapter 2, "Wiring Design and Protection." Article 210, using the applicable article "For Motors and Motor Controllers," (Article 430, Table 430-1 52).

IMPORTANT: Overload protection is required for all motors. Certain motors

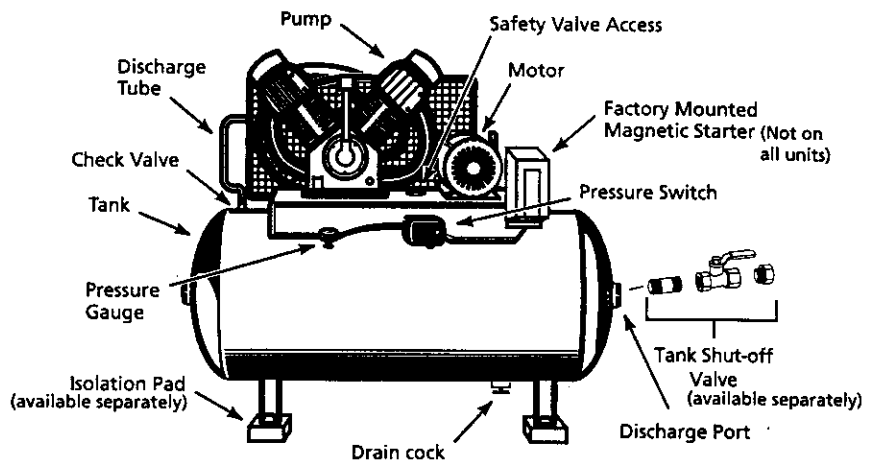

Figure 2 - Typical Horizontal Unit Identification

have this protection built-in. To determine if a motor has built-in overload protection, refer to the frame size on the motor nameplate.

Motors with frame size R56HZ, Y56Y or L143T include built-in overload protection. No additional protection is required. Use Figure 3 wiring diagram.

Motors with frame sizes 184T, 215T, 254T or 284T DO NOT have built-in overload protection. A magnetic starter is required. Use Figure 4 wiring diagram.

To change to the alternate voltage on three phase motors with 230/460 ratings:

1. Rewire motor per data plate on motor or instruction sheet.
2. Check electric rating of magnetic starter and replace thermal overload

elements or magnetic starter as required. The voltage and amperage ratings are listed on the motor nameplate.

DIRECTION OF ROTATION

NOTE: Improper rotation will result in reduced unit life.

The direction of rotation must be counterclockwise (as shown by the arrow on the flywheel) while facing the flywheel side of the pump. The motor nameplate will show wiring information for counterclockwise rotation.

The proper direction is very important. The direction of rotation of 3 phase motors can be reversed by interchanging any two motor-line leads. For single phase motors, refer to the motor nameplate.

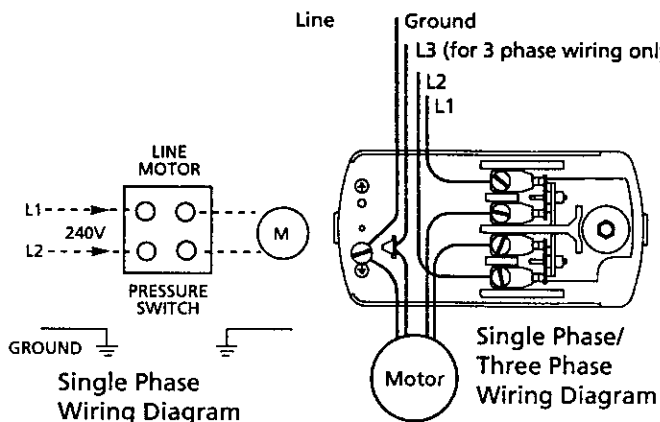

Figure 3 - For Motor Frame Sizes R56HZ, Y56Y or L143T. Refer to Motor Nameplate

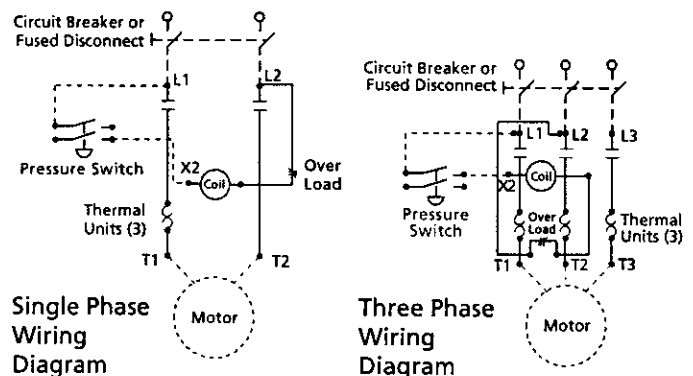

Figure 4 - For Motor Frame Sizes 184T, 215T, 254T or 284T. Refer to Motor Nameplate

Operation

IMPORTANT: Check motor rotation before operating the compressor.

All lubricated compressor pumps discharge some condensed water and oil with the compressed air. Install appropriate water/oil removal equipment and controls as necessary for the intended application.

NOTICE Failure to install appropriate water/oil removal equipment may result in damage to machinery or workpiece.

GUARDING

DANGER

The belt guard provided must be installed before operating the unit.



All moving parts must be guarded. All electrical covers must be installed before turning on the power.

LUBRICATION

CAUTION THIS UNIT CONTAINS NO OIL.

Before operating compressor. Fill to the center of the sight gauge or maximum mark on dipstick (see Figure 5).

Some residual oil may still be in the pump leaving a thin coat on the sight glass, however; there is not enough oil to operate the unit. Fill pump with single-viscosity, ISO100, non-detergent, compressor oil. Recommended ST126700AV compressor oil or Mobil 1® 5W30 or 10W30 synthetic oil may also be used. Add oil only through the oil fill plug. Pouring oil into any other orifice will cause oil to leak and spray out during operation. Fill to the center of the sight gauge or maximum mark on dipstick (see Figure 5).

CAUTION Using any other type of oil may shorten pump life and damage valves.

RECOMMENDED BREAK-IN PERIOD

The compressor should be run continuously for one hour to allow proper seating of the piston rings.

1. Open drain cock completely and run the compressor for 60 minutes (See Figure 6).

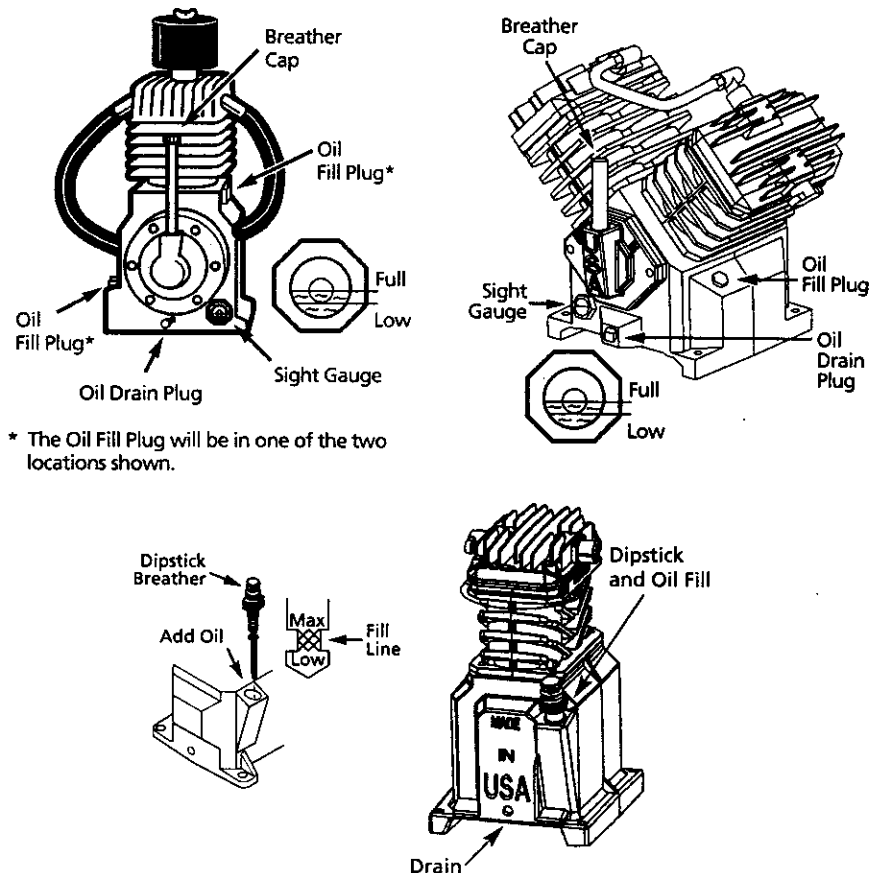

Figure 5 - Oil Fill Diagrams

2. Turn off the compressor and close drain cock. The compressor is now ready for use.

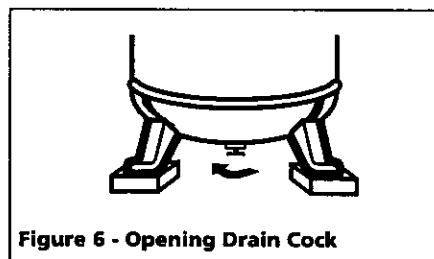

Figure 6 - Opening Drain Cock

If the compressor is run under humid conditions for short periods of time, the humidity will condense in the crankcase and cause the oil to look creamy. Oil contaminated by condensed water will not provide adequate lubrication and must be changed immediately. Using contaminated oil will damage bearings, pistons, cylinders and rings and is not covered under warranty. To avoid water condensation in the oil, periodically run the compressor with tank pressure near

150 psi for two-stage compressors or 120 psi for single stage compressors by opening the drain cock or an air valve connected to the tank or hose. Run the pump for an hour at a time at least once a week or more often if the condensation reoccurs.

IMPORTANT: Change oil after first 50 hours of operation.

PRESSURE SWITCH, START - STOP

NOTE: This compressor has a maximum operating pressure of 175 psi for two-stage compressors or 135 psi for single stage compressors. Do not alter pressure settings on control components above this limit.

The compressor unit starts and stops based on preset pressure switch settings. The pressure switch contains an unloader which is a small valve that vents air to allow the motor to start easily (See Figure 7).

Air Compressors

Operation (Cont.)

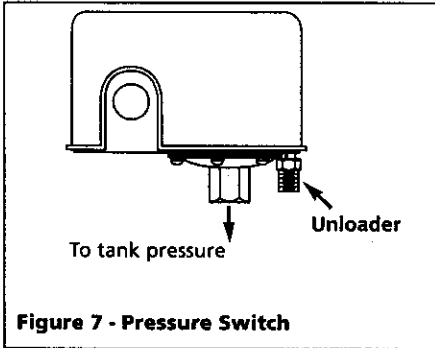

Figure 7 - Pressure Switch

CONTINUOUS RUN OPERATION

To convert to continuous run operation a separate unloading device must be installed by the user between the pump and the tank. The existing check valve must be removed.

CRANKCASE BREATHER

During severe operating conditions or initial start-up, some oil may accumulate at the crankcase breather opening. This is normal and will diminish as the pump accumulates run time and the piston rings become fully seated.

Maintenance

AWARNING

Disconnect, tag and lock out power source then release all pressure from the system before attempting to install, service, relocate or perform any maintenance.



In order to maintain efficient operation of the compressor system, check

the air filter and oil level before each use. The ASME safety valve should also be checked daily (See Figure 8). Pull ring on safety valve and allow the ring to snap back to normal position. This valve automatically releases air if the tank pressure exceeds the preset maximum. If air leaks after the ring has been released, or the valve is stuck and cannot be actuated by the ring, the ASME safety valve must be replaced.

DANGER Do not attempt to tamper with the ASME safety valve.

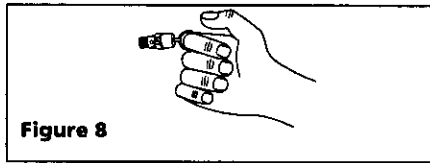

Figure 8

TANK

DANGER

Never attempt to repair or modify a tank! Welding, drilling or any other modification will weaken the tank resulting in damage from rupture or explosion. Always replace worn, cracked or damaged tanks.



NOTICE Drain liquid from tank daily.

The tank should be carefully inspected at a minimum of once a year. Look for cracks forming near the welds. If a crack is detected, remove pressure from tank immediately and replace.

COMPRESSOR LUBRICATION

See Operation. Add oil as required. The oil and oil filter should be changed every

three months or after every 500 hours of operation; whichever comes first. Only pressure lubricated pumps have an oil filter.

AIR FILTER

Never run the compressor pump without an intake air filter nor with a clogged intake air filter. Use compressed air to blow the filter clean. Do not wash or oil the element. If it cannot be blown clean, the filter must be replaced. Operating compressor with a dirty filter can cause high oil consumption and increase oil contamination in the discharge air.

INTERCOOLER (TWO-STAGE COMPRESSORS ONLY)

AWARNING Intercooler fins are sharp, always wear gloves and use care when you clean or work near the intercooler.

Weekly, check the intercooler to be sure all fittings are secure and tight. Blow all dirt, dust and other accumulations from the intercooler fins.

COMPONENTS

Turn off all power and use light air pressure to blow dust and foreign material from cylinder head, motor, fan blades, air lines, intercooler and tank on a monthly basis.

BELTS

AWARNING Lock out and tag the power then release all pressure from the tank to prevent unexpected movement of the unit.

Check belt tension every 3 months. Adjust belt tension to allow 3/8 to 1/2" deflection with normal thumb pressure. Also, align belts using a straight edge against the face of the flywheel and

MAINTENANCE SCHEDULE

Operation	Daily	Weekly	Monthly	3 Months
Check Safety Valve	●			
Drain Tank (See Figure 6)	●			
Check Oil Level	●			
Clean or Change Air Filter			●	
Check Intercooler (two-stage compressors only)		●		
Clean Unit Components			●	
Check Belt Tightness				●
Change Oil (See Figure 5)				●
Change Oil Filter (Pressure lubricated pumps only)				●

Maintenance (Cont.)

touching the rim on both sides of the face. The belts should be parallel to this straight edge (see Figure 9). Dimension A should be the same as B and C to ensure proper alignment of the belts. Slots in the bed-plate allow for sliding

the motor back and forth to adjust belt tension.

STORAGE

If compressor is to be stored for a short period of time, make sure that it is stored in a normal position and in a cool protected area.

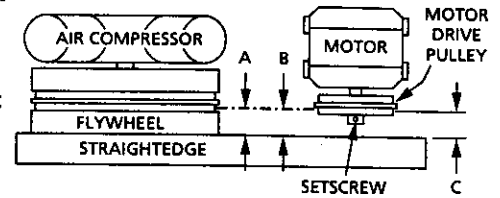

Figure 9 - Top View

Troubleshooting Chart

Symptom	Possible Cause(s)	Corrective Action
Motor hums and runs slowly or not at all	<ol style="list-style-type: none"> 1. Low voltage or no voltage 2. Shorted or open motor winding 3. Malfunctioning check valve or unloader valve 4. Malfunctioning pressure switch - contacts will not close 	<ol style="list-style-type: none"> 1. Check with voltmeter, check overload relay in magnetic starter or reset switch on motor. If overload or reset switch trips repeatedly, find and correct the cause. See next item 2. Replace motor 3. Replace check valve or unloader valve 4. Repair or replace pressure switch
Reset mechanism cuts out repeatedly or fuses blow repeatedly	<ol style="list-style-type: none"> 1. Pressure switch set too high 2. Malfunctioning check valve 3. Incorrect fuse size or magnetic starter heaters 4. Malfunctioning motor 5. Loose Wiring 	<ol style="list-style-type: none"> 1. Adjust or replace 2. Clean or replace faulty valve 3. Be sure that fuses and heaters are rated properly 4. Replace motor 5. Check all electrical connections
Excessive noise in operation	<ol style="list-style-type: none"> 1. Loose pulley, flywheel, belt, belt guard, etc 2. Lack of oil in crankcase 3. Compressor floor mounting loose 4. Malfunctioning check valve 	<ol style="list-style-type: none"> 1. Tighten 2. Check for damage to bearings, replenish oil 3. Shim to level and tighten or place on isolator pads 4. Replace check valve
Milky oil in oil reservoir	Water condensing in crankcase due to high humidity	Pipe air intake to less humid air source. Run pump continuously for one hour
Excessive oil consumption or oil in air lines	<ol style="list-style-type: none"> 1. Be sure there is a problem 2. Restricted air intake 3. Wrong oil viscosity 4. Worn piston rings 5. Oil leaks 6. Scored cylinder 	<ol style="list-style-type: none"> 1. Diagnose oil contamination problems by testing the discharge air or measuring oil consumption from the crankcase 2. Clean or replace air filter 3. Drain oil. Refill with oil of proper viscosity 4. Replace rings 5. Tighten bolts, replace gaskets or o-rings 6. Replace cylinder
Water in discharge air	<ol style="list-style-type: none"> 1. Excessive water in tank 2. Hot, humid weather 	<ol style="list-style-type: none"> 1. Drain tank 2. Purchase dryer
Air blowing out of inlet	Broken first stage inlet valve (two-stage unit) Broken inlet valve (single stage unit)	Replace valve assembly
Insufficient pressure	<ol style="list-style-type: none"> 1. Air demand too high 2. Leaks or restrictions in hoses or piping 3. Slipping belts 	<ol style="list-style-type: none"> 1. Limit air usage 2. Check for leaks or restriction in hose or piping 3. Tighten belts
Tank does not hold pressure when compressor is off and shutoff valve is closed	<ol style="list-style-type: none"> 1. Worn check valve 2. Check all connections and fittings for tightness 3. Check tank for cracks or pin holes 	<ol style="list-style-type: none"> 1. Replace check valve 2. Tighten 3. Replace tank. Never repair a damaged tank
		⚠ DANGER Do not disassemble check valve with air in tank
Excessive belt wear. (Light dust from start is normal. Worn belts separate at layers)	<ol style="list-style-type: none"> 1. Pulley out of alignment 2. Belts too tight or too loose 	<ol style="list-style-type: none"> 1. Realign motor pulley 2. Adjust tension
Tank pressure builds slowly	<ol style="list-style-type: none"> 1. Dirty air filter 2. Blown cylinder head gasket 3. Worn/broken intake/discharge valves 4. Air leaks 	<ol style="list-style-type: none"> 1. Clean or replace filter element 2. Install new gasket 3. Install new valve plate assembly 4. Tighten joints
Tank pressure builds up quickly on compressor	Excessive water in tank	Drain tank, check speed. See Performance table
ASME safety valve pops open while compressor is running	<ol style="list-style-type: none"> 1. Wrong pressure switch setting 2. Malfunctioning ASME safety valve 3. Pressure switch contacts welded 	<ol style="list-style-type: none"> 1. Adjust to lower pressure (175 psi maximum for two-stage unit or 135 psi for single stage unit) (See Operation) 2. Replace ASME safety valve 3. Replace pressure switch
Pressure switch continuously blows air out the unloader valve	Malfunctioning check valve	Replace the check valve if the unloader valve bleeds off constantly
Pressure switch unloader valve does not release air when the unit shuts off	Malfunctioning unloader valve on pressure switch	Replace the pressure switch if the unit does not hiss for a short period of time when the unit shuts off
Interstage safety valve pops off while the unit is running	<ol style="list-style-type: none"> 1. Head gasket or the gasket in the valve plate assembly blown 2. Valve not seating properly 3. Malfunctioning safety valve 	<ol style="list-style-type: none"> 1. Replace valve plate and gaskets 2. Replace valve plate and gaskets 3. Replace safety valve
Interstage safety valve pops off after the unit shuts off	Malfunctioning tank check valve	Replace the check valve

Limited Warranty

1. **DURATION:** From the date of purchase by the original purchaser as follows: Standard Duty - One Year; Serious Duty - Two Years; Extreme Duty - Three Years; Maxus Model Series - Five Years.
2. **WHO GIVES THIS WARRANTY (WARRANTOR):**
Campbell Hausfeld / Scott Fetzer Company, 100 Production Drive, Harrison, Ohio, 45030, Telephone: (800) 543-6400
3. **WHO RECEIVES THIS WARRANTY (PURCHASER):** The original purchaser (other than for purposes of resale) of the Campbell Hausfeld compressor.
4. **WHAT PRODUCTS ARE COVERED BY THIS WARRANTY:** Any Campbell Hausfeld air compressor.
5. **WHAT IS COVERED UNDER THIS WARRANTY:** Substantial defects due to material and workmanship with the exceptions noted below.
6. **WHAT IS NOT COVERED UNDER THIS WARRANTY:**
 - A. Implied warranties, including those of merchantability and FITNESS FOR A PARTICULAR PURPOSE ARE LIMITED FROM THE DATE OF ORIGINAL PURCHASE AS STATED IN THE DURATION. If this compressor is used for commercial, industrial or rental purposes, the warranty will apply for ninety (90) days from the date of purchase. Extreme Duty Contractor Compressors are not limited to a ninety (90) day warranty when used in contractor applications. Four cylinder single-stage and two-stage compressors are not limited to a ninety (90) day warranty when used in commercial or industrial applications. Some States do not allow limitations on how long an implied warranty lasts, so the above limitations may not apply to you.
 - B. ANY INCIDENTAL, INDIRECT, OR CONSEQUENTIAL LOSS, DAMAGE, OR EXPENSE THAT MAY RESULT FROM ANY DEFECT, FAILURE, OR MALFUNCTION OF THE CAMPBELL HAUSFELD PRODUCT. Some States do not allow the exclusion or limitations of incidental or consequential damages, so the above limitation or exclusion may not apply to you.
 - C. Any failure that results from an accident, purchaser's abuse, neglect or failure to operate products in accordance with instructions provided in the owner's manual(s) supplied with compressor.
 - D. Pre-delivery service, i.e. assembly, oil or lubricants, and adjustment.
 - E. Items or service that are normally required to maintain the product, i.e. lubricants, filters and gaskets, etc.
 - F. Gasoline engines and components are expressly excluded from coverage under this limited warranty. The Purchaser must comply with the warranty given by the engine manufacturer which is supplied with the product.
 - G. Additional items not covered under this warranty:
 1. All Compressors
 - a. Any component damaged in shipment or any failure caused by installing or operating unit under conditions not in accordance with installation and operation guidelines or damaged by contact with tools or surroundings.
 - b. Pump or valve failure caused by rain, excessive humidity, corrosive environments or other contaminants.
 - c. Cosmetic defects that do not interfere with compressor functionality.
 - d. Rusted tanks, including but not limited to rust due to improper drainage or corrosive environments.
 - e. Electric motors, check valves and pressure switches after the first year of ownership.
 - f. Drain cocks.
 - g. Damage due to incorrect voltage or improper wiring.
 - h. Other items not listed but considered general wear parts.
 - i. Pressure switches, air governors and safety valves modified from factory settings.
 2. Lubricated Compressors
 - a. Pump wear or valve damage caused by using oil not specified.
 - b. Pump wear or valve damage caused by any oil contamination or by failure to follow proper oil maintenance guidelines.
 3. Belt Drive / Direct Drive / Gas Driven Compressors
 - a. Belts.
 - b. Ring wear or valve damage from inadequate filter maintenance.
 - c. Manually adjusted load/unload and throttle control devices.
7. **RESPONSIBILITIES OF WARRANTOR UNDER THIS WARRANTY:** Repair or replace, at Warrantor's option, compressor or component which is defective, has malfunctioned and/or failed to conform within duration of the warranty period.
8. **RESPONSIBILITIES OF PURCHASER UNDER THIS WARRANTY:**
 - A. Provide dated proof of purchase and maintenance records.
 - B. Portable compressors or components must be delivered or shipped to the nearest Campbell Hausfeld Authorized Service Center. Freight costs, if any, must be borne by the purchaser.
 - C. Use reasonable care in the operation and maintenance of the products as described in the owner's manual(s).
9. **WHEN WARRANTOR WILL PERFORM REPAIR OR REPLACEMENT UNDER THIS WARRANTY:** Repair or replacement will be scheduled and serviced according to the normal work flow at the servicing location, and depending on the availability of replacement parts.

This Limited Warranty applies in the U.S., Canada and Mexico only and gives you specific legal rights. You may also have other rights which vary from State to State or country to country.