

Model No. 831.291030

Serial No. _____

Serial Number Decal

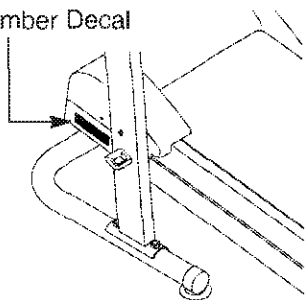

- Assembly
- Operation
- Maintenance
- Part List and Drawing

⚠ CAUTION

Read all precautions and instructions in this manual before using this equipment. Save this manual for future reference.

TREADMILL EXERCISER

User's Manual

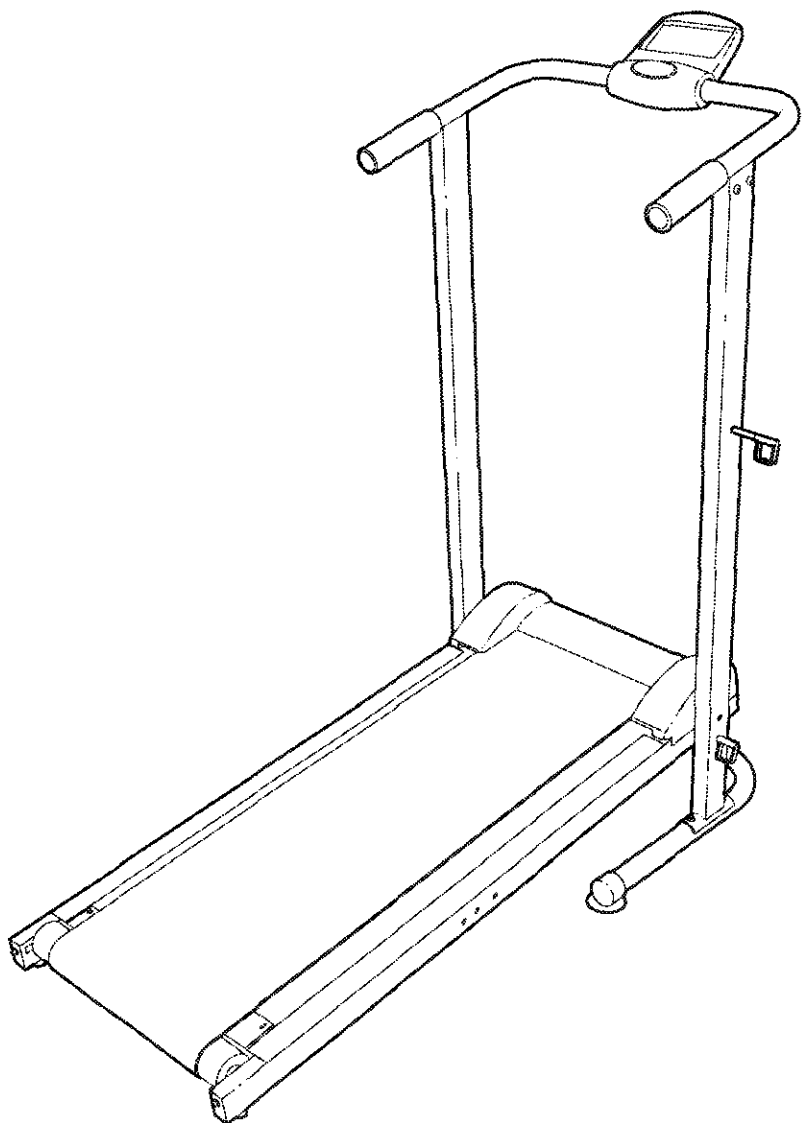

TABLE OF CONTENTS

IMPORTANT PRECAUTIONS	2
BEFORE YOU BEGIN	3
ASSEMBLY	4
TREADMILL OPERATION	6
MAINTENANCE AND TROUBLESHOOTING	8
CONDITIONING GUIDELINES	9
PART LIST	10
EXPLODED DRAWING	11
ORDERING REPLACEMENT PARTS	Back Cover
FULL 90 DAY WARRANTY	Back Cover

IMPORTANT PRECAUTIONS

▲ WARNING: To reduce the risk of serious injury, read the following important precautions before using the treadmill.

1. It is the responsibility of the owner to ensure that all users of the treadmill are adequately informed of all warnings and precautions.
2. Use the treadmill only as described.
3. This treadmill is intended for in-home use only. Do not use the treadmill in a commercial, rental, or institutional setting.
4. Place the treadmill on a level surface, with eight feet of clearance behind it. Place a mat under the treadmill to protect the floor.
5. Inspect and properly tighten all parts of the treadmill regularly; replace any worn parts immediately.
6. The roller guards must be 1/8 inch from the rear roller (see the drawing on page 3). Adjust the roller guards, if necessary.
7. Keep children under the age of 12 and pets away from the treadmill at all times.
8. The treadmill should not be used by persons weighing over 250 pounds. Never allow more than one person on the treadmill at a time.
9. Wear appropriate clothing when exercising. Do not wear loose clothing that could become caught on the treadmill.
10. Always wear athletic shoes when using the treadmill; do not use the treadmill with bare feet, wearing only stockings, or in sandals.
11. Do not use the treadmill if it is not working properly.
12. Do not place hands or feet under the treadmill while it is in use.
13. Always hold the handrail when mounting, dismounting, or exercising on the treadmill.
14. If you feel pain or dizziness while exercising, stop immediately and begin cooling down.
15. The decal shown below has been placed on the treadmill in the location shown on page 3. If the decal is missing or illegible, call toll-free 1-800-999-3756 and order a free replacement decal. Apply the decal in the location shown.

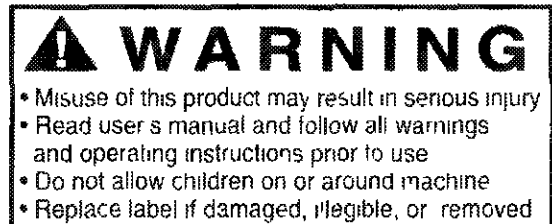

▲ WARNING: Before beginning this or any exercise program, consult your physician. This is especially important for persons over the age of 35 or persons with pre-existing health problems. Read all instructions before using this product. Sears assumes no responsibility for personal injury or property damage sustained by or through the use of this product.

BEFORE YOU BEGIN

Thank you for selecting the new WESLO® SMOOTHSTRIDER treadmill. The SMOOTHSTRIDER treadmill is designed to let you enjoy effective cardiovascular workouts in the comfort and convenience of your home. And when the SMOOTHSTRIDER treadmill is not in use, it can be folded up, requiring less than half the space of other treadmills.



For your benefit, read this manual carefully before using the treadmill. If you have questions after read-

ing this manual, call 1-800-4-MY-HOME® (1-800-469-4663). To help us assist you, please note the product model number and serial number before calling. The model number of the treadmill is 831.291030. The serial number can be found on a decal attached to the treadmill (see the front cover of this manual for the location).

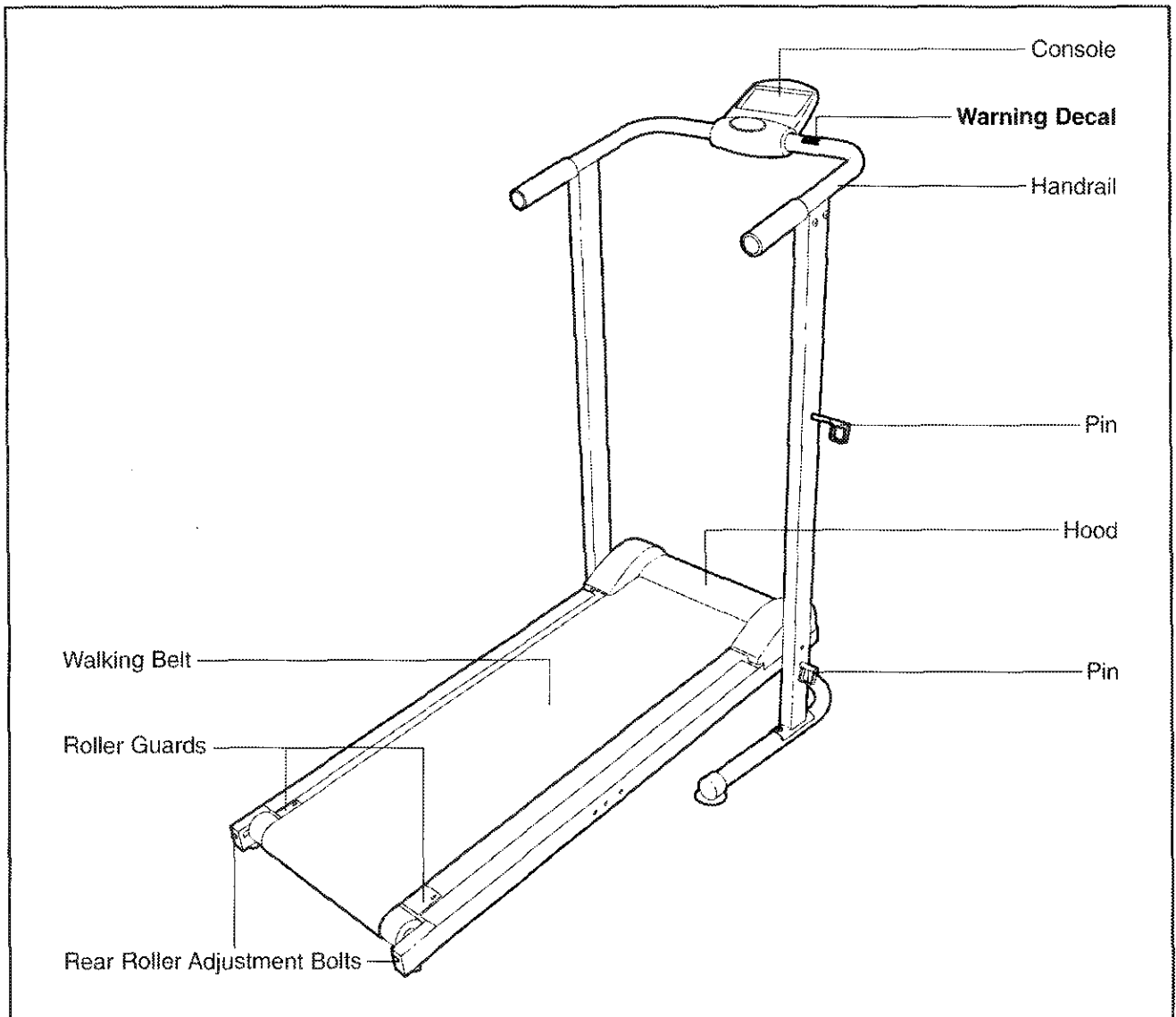
Before reading further, please review the drawing below and familiarize yourself with the labeled parts.



ASSEMBLY

The help of a second person is recommended. Set the treadmill in a cleared area and remove all packing materials. Do not dispose of the packing materials until assembly is completed. **Assembly requires only the included allen wrench  and wrench .**

1. Identify the Right Upright (36), which has a single hole in the indicated location. Hold the Right Upright against the Base (14) as shown, and orient the Right Upright so the two indicated holes are on the side shown.

Attach the Right Upright (36) to the Base (14) with two M8 x 50mm Bolts (38), two M8 Curved Washers (37), and two M8 Nylon Nuts (13) as shown.

Attach the Left Upright (35) to the Base (14) in the same way. Make sure that the Left Upright is oriented so the two indicated holes are on the side shown.

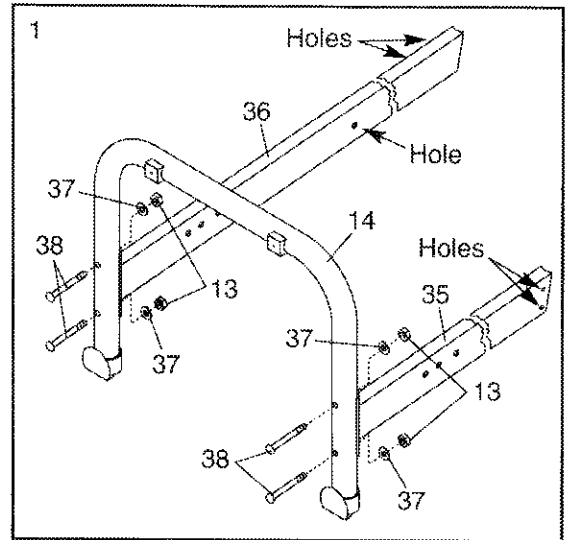

2. Raise the Left Upright (35) and the Right Upright (36) to the position shown. Feed the Reed Switch Wire (6) into the top of the Left Upright and out of the indicated hole.

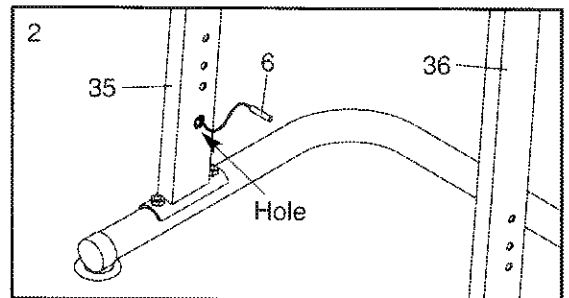

3. Attach the Hood (28) to the front of the Frame (29) with two M5 x 10mm Bolts (10).

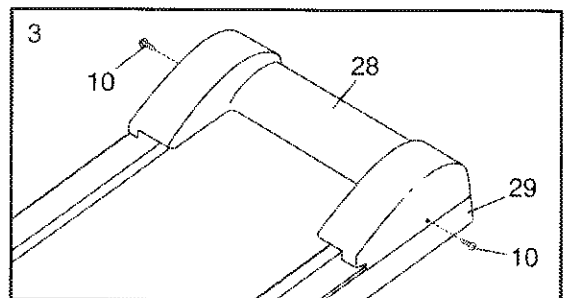

4. See drawing 4a. Hold the front of the Frame (29) between the Left Upright (35) and the Right Upright (not shown). Align the holes near the front of the Frame with one of the three sets of adjustment holes in the Uprights. Insert a Pin (4) into each Upright and each side of the Frame. **Make sure that the Pins are fully inserted at the same height.**

Look under the Frame (29) near the Left Upright (35). See drawing 4b. Locate the Clip (11) attached to the underside of the Frame. Insert the Reed Switch (6) into the Clip as shown. Next, locate the Magnet (12) on the left Flywheel (9). Turn the Flywheel until the Magnet is aligned with the Reed Switch. **Move the Reed Switch so that there is a 1/8" gap between the Reed Switch and the Magnet.** Then, tighten the M4 x 12mm Screw (3) in the Clip.

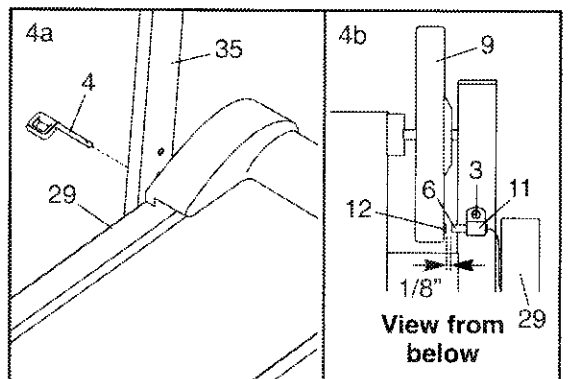

5. Hold the Handrail (5) near the Left and Right Uprights (35, 36). Connect the Handrail Wire (2) to the Reed Switch Wire (6). Insert the Wires down into the Left Upright.

Attach the Handrail (5) to the Uprights (35, 36) with four M8 x 15mm Bolts (33) and four M8 Washers (34). **Be careful not to pinch the Wires (2, 6).**

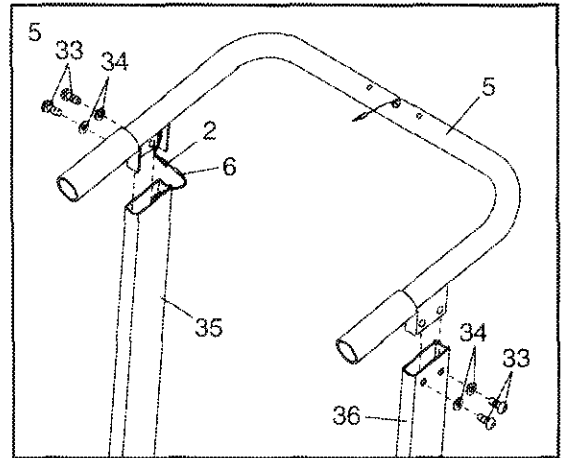

6. The Console (1) requires two “AAA” batteries. Alkaline batteries are recommended. Press the indicated tab on the Battery Cover (27) and remove the Battery Cover. Insert two batteries into the two battery clips; **make sure that the negative (–) ends of the batteries are touching the springs in the battery clips.**

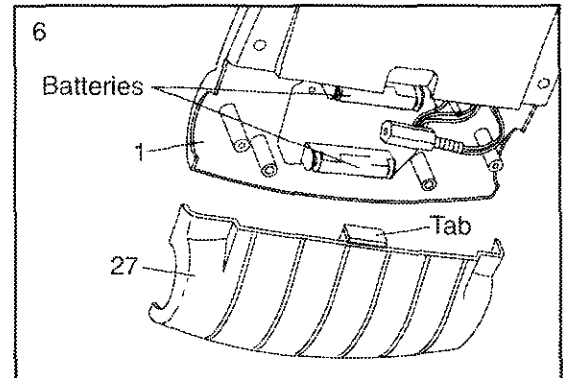

7. See drawing 7a. Hold the Console (1) near the Handrail (5). Connect the wire on the Console to the Handrail Wire (2). Attach the Console to the Handrail with two M4 x 12mm Screws (3). **Make sure that the wires are not pinched.**

See drawing 7b. Press the Battery Cover (27) back onto the Console (1).

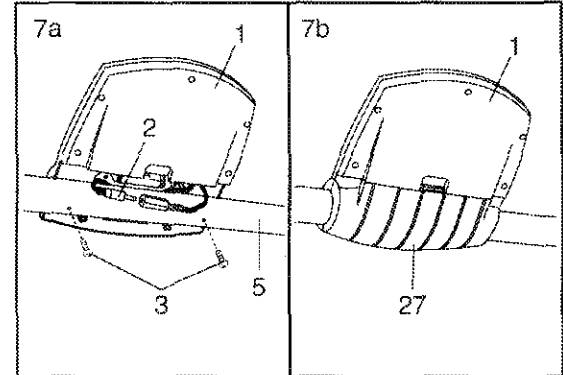

8. Remove the paper backing from the Adhesive Clip (30). Press the Adhesive Clip onto the left side of the Frame (29) in the indicated location. Press the Allen Wrench (20) into the Adhesive Clip.

Make sure that the walking belt is properly tightened (see SYMPTOM 3 on page 8).

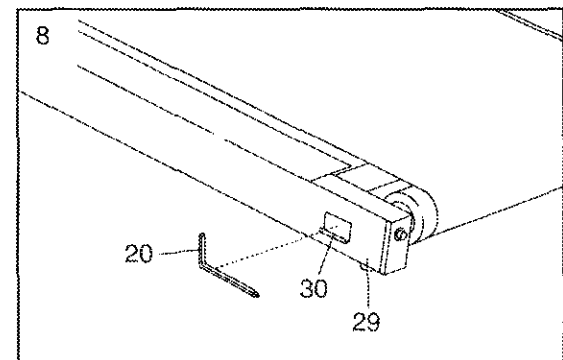

9. **Make sure that all parts are properly tightened before you use the treadmill.** To protect the floor or carpet, place a mat under the treadmill.

TREADMILL OPERATION

LUBRICATING THE WALKING PLATFORM

Before the treadmill is used, the walking platform should be lubricated. Open the included lubricant packet. Reach under one side of the walking belt as far as you can, and apply half of the lubricant to the walking platform. Then, reach under the other side of the walking belt and apply the remaining lubricant. **After you have applied the lubricant, walk on the treadmill for a few minutes to spread the lubricant.**

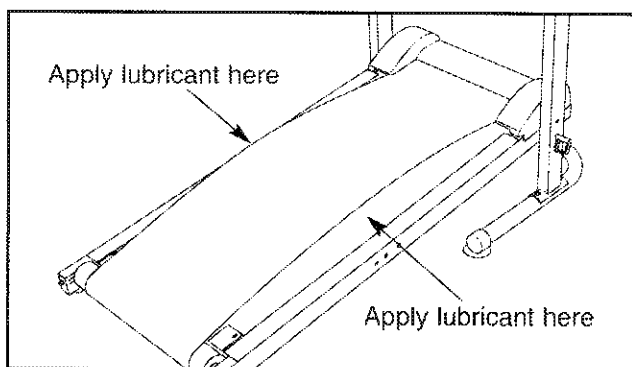

STEP-BY-STEP CONSOLE OPERATION

Before the console can be operated, batteries must be installed (see assembly step 6 on page 5). If there is a thin sheet of plastic on the console, remove the plastic.

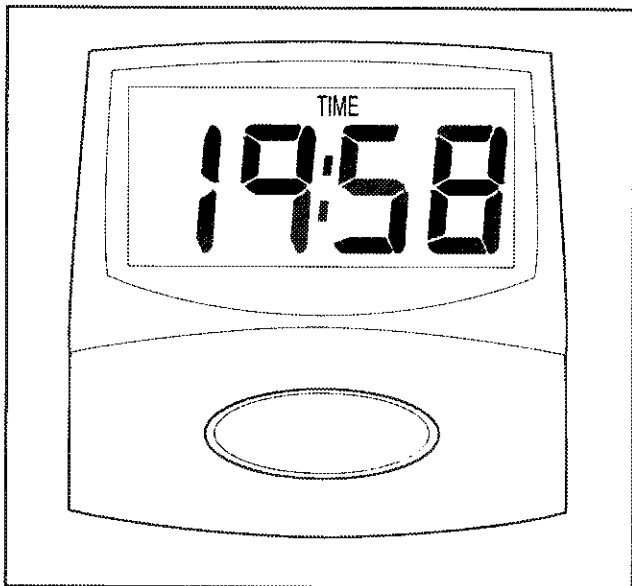

The console features six modes:

- Speed—This mode displays your speed, in miles per hour.
- Distance—This mode displays the number of miles you have walked.
- Time—This mode displays the elapsed time.
- Odometer—This mode displays the distance that the walking belt has moved since the batteries were changed.
- Calorie—This mode displays the approximate number of calories you have burned.
- Scan—This mode displays the Speed, Distance, Time, Odometer, and Calorie modes.

Follow the steps below to operate the console.

1. Turn on the power.

To turn on the power, press the console button or begin walking. Note: If batteries were just installed, the power will already be on.

2. Track your progress with the six modes.

When the power is turned on, the Scan mode will be selected and the SCAN indicator will appear. The console will display the Speed, Distance, Time, Odometer, and Calorie modes, for about six seconds each, in a repeating cycle.

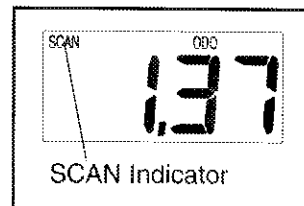

To select only the Speed, Distance, Time, Odometer, or Calorie mode, press the console button until only the SPEED, DIST, TIME, ODO, or CAL indicator appears in the display. Make sure that the SCAN indicator does not appear.

To reset all modes (except for the odometer mode), press the console button for about three seconds.

3. Turn off the power.

To turn off the power, simply wait for a few minutes. If the walking belt is not moved and the console button is not pressed for a few minutes, **the power will turn off automatically.**

INCLINE ADJUSTMENT

The incline of the treadmill can be adjusted to any of three positions. Hold the front of the Frame (29), and remove the two Pins (4). Raise or lower the Frame, align the holes in the Frame with one of the sets of holes in the Uprights (35, 36), and then re-insert the Pins. **Make sure both Pins are fully inserted at the same height.**

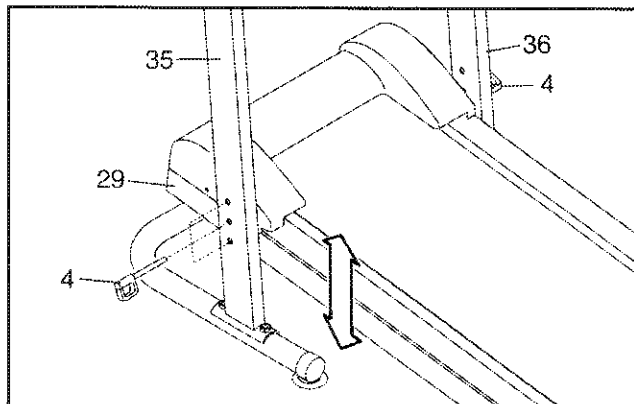

CAUTION: Make sure both Pins (4) are fully inserted at the same height.

FOLDING THE TREADMILL FOR STORAGE

When the treadmill is not in use, it can be folded to the compact storage position. **CAUTION: You must be able to safely lift 25 pounds (11 kg) to raise, lower, or move the treadmill.**

1. Hold the treadmill with your hands in the locations shown below. **CAUTION: To decrease the possibility of injury, bend your legs and keep your back straight. As you raise the treadmill, make sure to lift with your legs rather than your back.** Raise the treadmill to the vertical position.

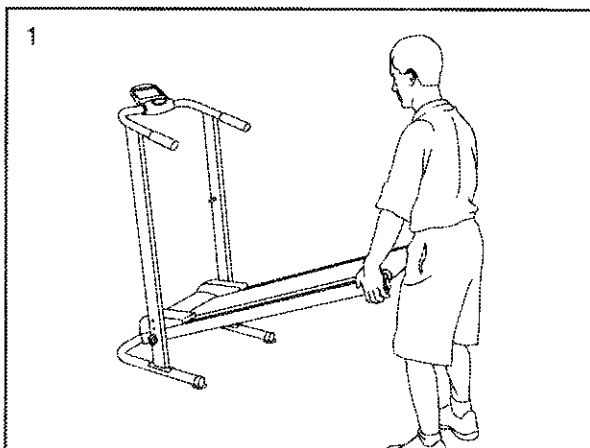

2. Hold the treadmill securely with your left hand as shown. Insert a Pin (4) into the hole in the right side of the Right Upright (36) and into the Frame (29) **as far as it will go.** Attach the Spring Clip (42) over the notch near the end of the Pin. Note: Squeezing the handles on the Spring Clip will help you to slide it onto the Pin.

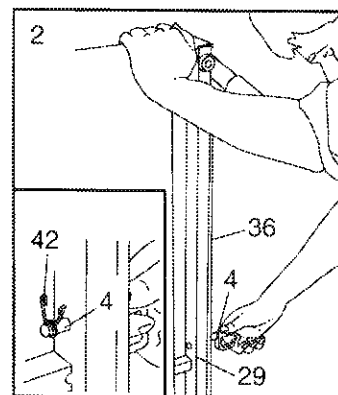

LOWERING THE TREADMILL FOR USE

1. Hold the treadmill securely with your left hand as shown in drawing 2 above. Squeeze the handles on the Spring Clip (42) and pull out the Pin (4). Pivot the treadmill down a few inches and re-insert the Pin and attach the Spring Clip.
2. Hold the treadmill firmly with both hands, and lower the treadmill to the floor. **CAUTION: To decrease the possibility of injury, bend your legs and keep your back straight.**

MAINTENANCE AND TROUBLESHOOTING

Most treadmill problems can be solved by following the simple steps below. Find the symptom that applies, and follow the steps listed. If further assistance is needed, call toll-free 1-800-4-MY-HOME® (1-800-469-4663).

1. SYMPTOM: THE CONSOLE DOES NOT FUNCTION PROPERLY

- a. Replace the batteries in the console (see assembly step 6 on page 5).
- b. Make sure that the reed switch is properly adjusted (see assembly step 4 on page 4).
- c. Make sure that the handrail wire is plugged fully into the wire on the console (see assembly step 7 on page 5).
- d. The console, like most electronics, is susceptible to static electricity build-up caused by certain types of clothing or by the operation of the treadmill. If the display is blank or gives incorrect readings, apply an anti-static spray to the handrail. Anti-static spray is available where laundry supplies are sold.

2. SYMPTOM: THE WALKING BELT DOES NOT MOVE SMOOTHLY

- a. If the walking belt is overtightened, performance may be reduced and the walking belt may be permanently damaged. Using the allen

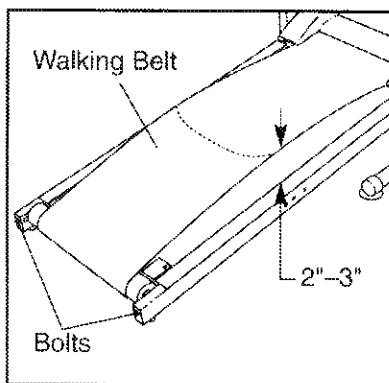

wrench, turn both rear roller adjustment bolts counterclockwise 1/4 of a turn. When the tension of the walking belt is correct, you should be able to lift each side of the walking belt 2 to 3 inches. Walk on the treadmill for a few minutes. Repeat until the walking belt is properly tightened. Be careful to keep the walking belt centered.

3. SYMPTOM: THE WALKING BELT SLIPS OR IS OFF-CENTER

- a. If the walking belt slips when walked on, use the allen wrench to turn both adjustment bolts clockwise,

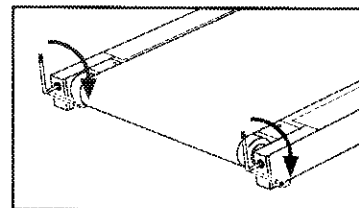

1/4 of a turn. When the walking belt is correctly tightened, you should be able to lift each side of the walking belt 2 to 3 inches. Walk on the treadmill for a few minutes. Repeat until the walking belt is properly tightened. Be careful to keep the walking belt centered.

- b. If the walking belt has shifted to the left side, use the allen wrench to turn the left adjustment bolt clockwise, and

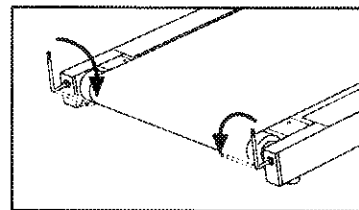

the right adjustment bolt counterclockwise, 1/4 of a turn each. Be careful not to overtighten the walking belt. Walk on the treadmill for a few minutes. Repeat until the walking belt is centered.

- c. If the walking belt has shifted to the right side, use the allen wrench to turn the left adjustment bolt counterclockwise, and

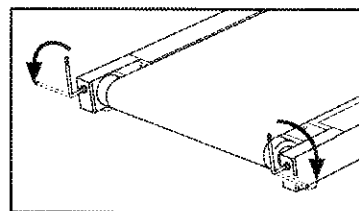

the right adjustment bolt clockwise, 1/4 of a turn each. Be careful not to overtighten the walking belt. Walk on the treadmill for a few minutes. Repeat until the walking belt is centered.

CONDITIONING GUIDELINES

The following guidelines will help you to plan your exercise program. Remember that proper nutrition and adequate rest are essential for successful results.

⚠ WARNING: Before beginning this or any exercise program, consult your physician. This is especially important for individuals over the age of 35 or individuals with pre-existing health problems.

WHY EXERCISE?

Exercise has proven essential for good health and well-being. A well-rounded exercise program helps to develop a stronger and more efficient heart, improved respiratory function, increased stamina, better weight management, increased ability to handle stress, and greater self-esteem.

EXERCISE INTENSITY

Whether your goal is to burn fat or to strengthen your cardiovascular system, the key to achieving the desired results is to exercise with the proper intensity. The proper intensity level can be found by using your heart rate as a guide. The chart below shows recommended heart rates for fat burning and aerobic exercise.

HEART RATE TRAINING ZONES							
AEROBIC	165	155	145	140	130	125	115
MAX FAT BURN	145	138	130	125	118	110	103
FAT BURN	125	120	115	110	105	95	90
Age	20	30	40	50	60	70	80

To find the proper heart rate for you, first find your age near the bottom of the chart (ages are rounded off to the nearest ten years). Next, find the three numbers above your age. The three numbers are your "training zone." The lower two numbers are recommended heart rates for fat burning; the highest number is the recommended heart rate for aerobic exercise.

Burning Fat

To burn fat effectively, you must exercise at the proper intensity level for a sustained period of time. During

the first few minutes of exercise, your body uses easily accessible *carbohydrate* calories for energy. Only after the first few minutes does your body begin to use stored *fat* calories for energy. If your goal is to burn fat, adjust the intensity of your exercise until your heart rate is between the lower two numbers in your training zone as you exercise.

Aerobic Exercise

If your goal is to strengthen your cardiovascular system, your exercise must be "aerobic." Aerobic exercise is activity that requires large amounts of oxygen for prolonged periods of time. This increases the demand on the heart to pump blood to the muscles, and on the lungs to oxygenate the blood. For effective aerobic exercise, adjust the intensity of your exercise until your heart rate is near the highest number in your training zone.

HOW TO MEASURE YOUR HEART RATE

To measure your heart rate, stop exercising and place two fingers on your wrist as shown. Take a six-second heartbeat count, and multiply the result by ten to find your heart rate.

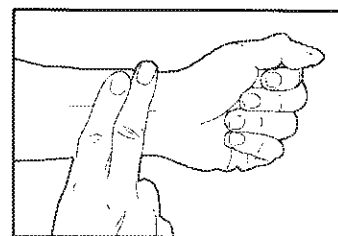

(A six-second count is used because your heart rate drops quickly when you stop exercising.) If your heart rate is too high, decrease the intensity of your exercise. If your heart rate is too low, increase the intensity of your exercise.

WORKOUT GUIDELINES

Each workout should include the following three important parts:

A warm-up, consisting of five to ten minutes of stretching and light exercise. This will increase your body temperature, heart rate, and circulation in preparation for exercise.

Training zone exercise, including 20 to 30 minutes of exercise with your heart rate in your training zone.

A cool-down, consisting of five to ten minutes of stretching. Stretching after exercise is effective for increasing flexibility and helps to offset problems caused when you stop exercising suddenly.

EXERCISE FREQUENCY

To maintain or improve your condition, plan three workouts each week, with at least one day of rest after each workout. After a few months of regular exercise, you may complete up to five workouts each week, if desired.

Instead of waiting for a convenient time to exercise, plan a specific time. The morning hours work well for many, and the self-discipline required to rise early and exercise increases productivity throughout the day. For others, exercising before dinner helps them to relax. Whatever time you choose, be consistent. The key to success is to make exercise a regular and enjoyable part of your everyday life.

PART LIST—Model No. 831.291030

R0903A

Key No.	Qty.	Description	Key No.	Qty.	Description
1	1	Console	24	2	Frame Plate
2	1	Handrail Wire	25	1	Rear Roller
3	3	M4 x 12mm Screw	26	1	Wrench
4	3	Pin	27	1	Battery Cover
5	1	Handrail	28	1	Hood
6	1	Reed Switch/Wire	29	1	Frame
7	10	M5 x 20mm Bolt	30	1	Adhesive Clip
8	2	Frame Endcap	31	2	Handrail Endcap
9	1	Front Roller/Flywheel	32	2	Handrail Foam Grip
10	4	M5 x 10mm Bolt	33	4	M8 x 15mm Bolt
11	1	Reed Switch Clip	34	4	M8 Washer
12	1	Magnet	35	1	Left Upright
13	4	M8 Nylon Nut	36	1	Right Upright
14	1	Base	37	4	M8 Curved Washer
15	2	Base Pad	38	4	M8 x 50mm Bolt
16	2	Roller Guard	39	1	Grommet
17	2	Base Endcap	40	1	Warning Decal
18	1	Walking Belt	41	2	Platform Cover
19	1	Walking Platform	42	1	Spring Clip
20	1	Allen Wrench	#	1	User's Manual
21	2	Frame Foot			
22	2	Rear Roller Adjustment Bolt			
23	2	Rear Roller Washer			

These parts are not illustrated.

Specifications are subject to change without notice. **If a part is missing, call toll-free 1-800-999-3756.** See the back cover for information about ordering replacement parts.

EXPLODED DRAWING—Model No. 831.291030

R0903A

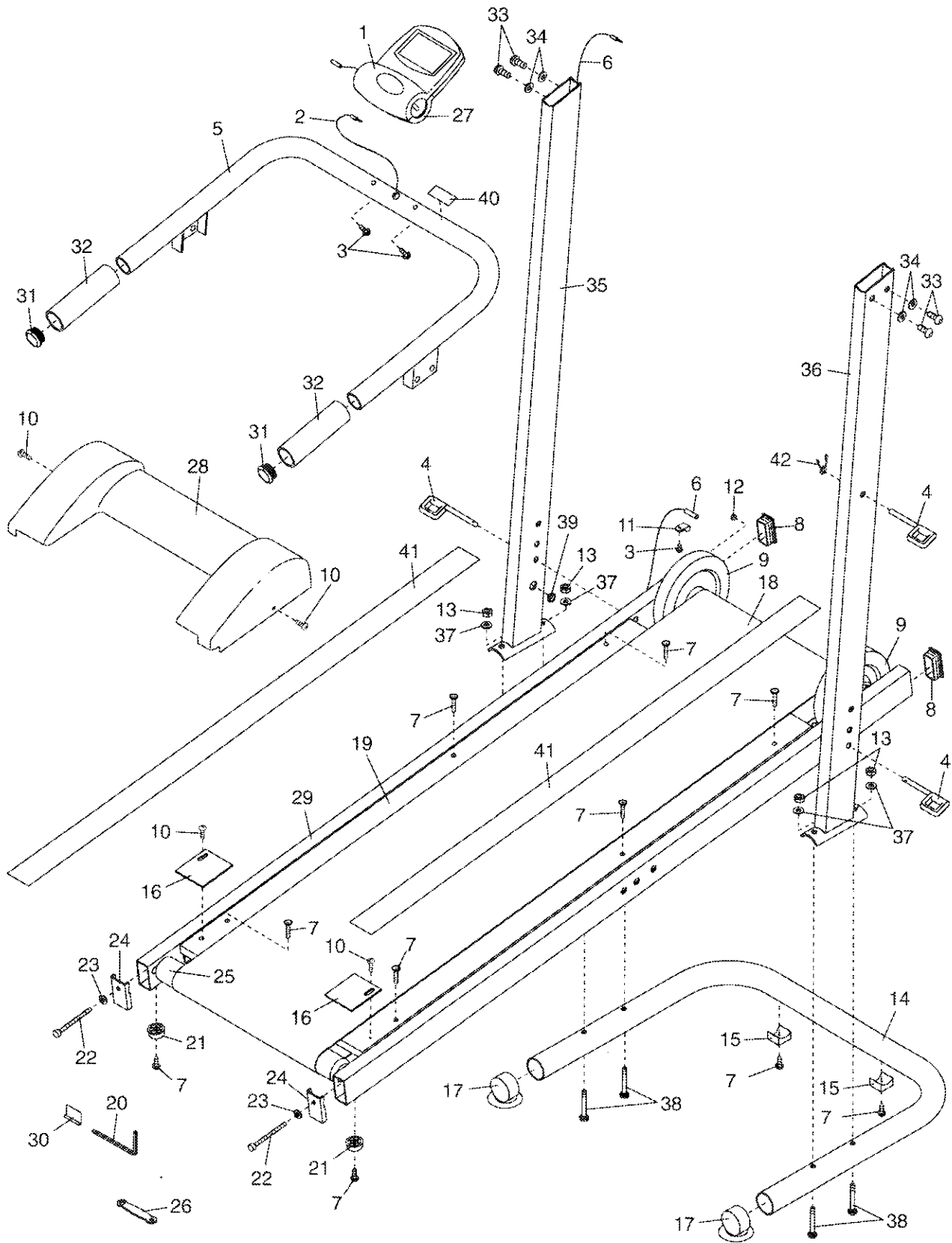

Get it fixed, at your home or ours!

Your Home

For repair – **in your home** – of **all** major brand appliances, lawn and garden equipment, or heating and cooling systems, **no matter who made it, no matter who sold it!**

For the replacement parts, accessories, and user's manuals that you need to do-it-yourself.

For Sears professional installation of home appliances and items like garage door openers and water heaters.

1-800-4-MY-HOME®

(1-800-469-4663)

www.sears.com

Anytime, day or night

(U S A and Canada)

www.sears.ca

Our Home

For repair of carry-in products like vacuums, lawn equipment, and electronics, call or go on-line for the location of your nearest **Sears Parts and Repair Center.**

1-800-488-1222 Anytime, day or night (U S A only)

www.sears.com

To purchase a protection agreement (U.S.A.) or maintenance agreement (Canada) on a product serviced by Sears:

1-800-827-6655 (U.S.A.)

1-800-361-6665 (Canada)

Para pedir servicio de reparación a domicilio, y para ordenar piezas:

1-888-SU-HOGARSM (1-888-784-6427)

SEARS

® Registered Trademark / ™ Trademark / ™ Service Mark of Sears, Roebuck and Co
® Marca Registrada / ™ Marca de Fábrica / ™ Marca de Servicio de Sears, Roebuck and Co

FULL 90 DAY WARRANTY

For 90 days from the date of purchase, if failure occurs due to defect in material or workmanship in this Sears Treadmill Exerciser, contact the nearest Sears Service Center throughout the United States and Sears will repair or replace the Treadmill Exerciser free of charge

This warranty does not apply when the Treadmill Exerciser is used commercially or for rental purposes

This warranty gives you specific legal rights, and you may also have other rights which vary from state to state

Sears, Roebuck and Co., Dept. 817WA, Hoffman Estates, IL 60179