

ENGLISH

Video Camcorder

8mm
COLOR LCD

SCL901/L906/L907

Hi8 SCL901/L906/L907

Owner's Instruction Book

Before operating the unit, please read this instruction book thoroughly, and retain it for future reference.

US PATENT 4415844

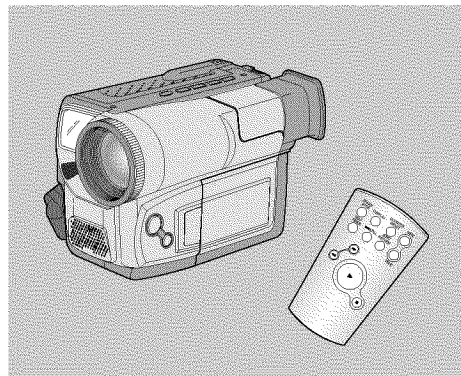



SAMSUNG

ELECTRONICS

ENGLISH

Notices and Safety Instructions

Safety Instructions

	CAUTION RISK OF ELECTRIC SHOCK DO NOT OPEN	
CAUTION: TO REDUCE THE RISK OF ELECTRIC SHOCK, DO NOT REMOVE COVER (OR BACK). NO USER SERVICEABLE PARTS INSIDE. REFER SERVICING TO QUALIFIED SERVICE PERSONNEL.		

To prevent electric shock, match wide blade of plug to wide slot and fully insert.



This symbol is intended to alert the user to the presence of uninsulated dangerous voltage within the product's enclosure that may be of sufficient magnitude to constitute a risk of fire or electric shock.



This symbol is intended to alert the user to the presence of important operating and maintenance instructions in the literature accompanying this product.

1. READ INSTRUCTIONS:

All the safety and operating instructions should be read before the CAMCORDER is operated.

2. RETAIN INSTRUCTIONS:

The safety and operating instructions should be retained for future reference.

3. HEED WARNINGS:

All warnings on the CAMCORDER and in the operating instructions should be adhered to.

4. FOLLOW INSTRUCTIONS:

All operating and maintenance instructions should be followed.

5. CLEANING:

Unplug this CAMCORDER from the wall outlet before cleaning.

Do not use liquid or aerosol cleaners.

Use a dry cloth used for dusting cabinets.

6. ATTACHMENTS:

Do not use attachments not recommended by the CAMCORDER product manufacturer as they may be hazardous.

7. WATER AND MOISTURE:

Do not use this CAMCORDER near water; for example, near a bathtub, wash bowl, kitchen sink, laundry tub, in a wet basement, near a swimming pool or lake.

8. ACCESSORIES:

Do not place this CAMCORDER on an unstable cart, stand, tripod, bracket or table. The CAMCORDER may fall, causing serious injury to a child or adult, and serious damage to the unit.

Use only with a cart, stand, tripod, bracket, or table recommended by the manufacturer or sold with the CAMCORDER. Any mounting of the unit should follow the manufacturer's instructions and should use a mounting accessory recommended by the manufacturer.

A. An appliance and cart combination should be moved with care.

Quick stops, excessive force and uneven surfaces may cause the appliance and cart combination to overturn.

PORTABLE CART WARNING
(Symbol provided by RETAC)



Notices and Safety Instructions

9. VENTILATION:

Slots and openings in the cabinet are provided for ventilation to ensure reliable operation of the CAMCORDER and to protect it from overheating. These openings must not be blocked or covered. Never place your CAMCORDER on a bed, sofa, rug, or other similar surface: on or near a radiator or heat register.

This CAMCORDER should not be placed in a built-in installation such as a bookcase or rack unless proper ventilation is provided or the manufacturer's instructions have been adhered to.

10. POWER SOURCES:

The CAMCORDER should be operated only from the type of power source indicated on the label.

If you are not sure of the type of power supply at your home, consult your appliance dealer or local power company.

A CAMCORDER is intended to be operated from battery power, or other sources, refer to the operating instructions.

11. GROUNDING OR POLARIZATION:

This CAMCORDER may be equipped with either a polarized 2-wire AC line plug (a plug having one blade wider than the other) or a 3-wire grounding type plug, a plug having a third (grounding) pin.

If you are unable to insert the plug fully into the outlet, try reversing the plug. If the plug still fails to fit, contact your electrician to replace your outlet. Do not defeat the safety purpose of the polarized plug.

12. POWER-CORD PROTECTION:

Power-supply cords should be routed so that they are not likely to be walked on or pinched by items placed upon or against them, paying particular attention to cords or plugs, convenient receptacles, and the point where they exit from the unit.

13. OUTDOOR ANTENNA GROUNDING:

If an outside antenna or cable system is connected to the CAMCORDER, be sure the antenna or cable system is grounded to provide some protection against voltage surges and built-up static charges, Section 810 of the National Electrical Code, ANSI/NFPA No. 70-1984, provides information with respect to proper grounding of the mast and supporting structure, grounding of the lead-in wire and supporting structure, grounding of the mast and supporting structure, grounding of the lead-in wire to an antenna discharge unit, size of grounding to conductors, location of antenna-discharge unit, connection to grounding electrodes and requirements for the grounding electrode.

See figure below.

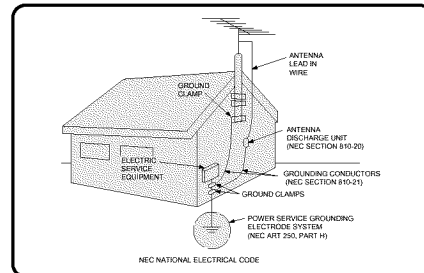

ENGLISH

Notices and Safety Instructions

14. LIGHTNING:

For added protection of this CAMCORDER during a lightning storm when it is left unattended and unused for long periods of time, unplug it from the wall outlet and disconnect the antenna or cable system.

This will prevent damage to the CAMCORDER due to lightning and power-line surges.

15. POWER LINES:

An outside antenna system should not be located in the vicinity of overhead power lines or other electric light or power circuits where it can fall into such power lines or circuits. When installing an outside antenna system, extreme care should be taken to keep from touching such power lines or circuits as contact with them might be fatal.

16. OVERLOADING:

Do not overload wall outlets and extension cords as this can result in a risk of fire or electric shock.

17. OBJECTS AND LIQUIDS:

Never push objects of any kind into this CAMCORDER through openings as they may touch dangerous voltage points or short out a part that could result in a fire or electric shock.

Never spill liquids of any kind onto the CAMCORDER. Should spillage occur, unplug unit and have it checked by a technician before use.

18. SERVICING:

Do not attempt to service this CAMCORDER yourself. Opening or removing covers may expose you to dangerous voltage or other hazards. Refer all servicing to qualified service personnel.

19. DAMAGE REQUIRING SERVICE:

Unplug this CAMCORDER from the wall outlet and refer servicing to qualified service personnel under the following conditions:

- a. When the power-supply cord or plug is damaged.
- b. If any liquid has been spilled onto, or objects have fallen into the CAMCORDER.
- c. If the CAMCORDER has been exposed to rain or water.
- d. If the CAMCORDER does not operate normally by following the operating instructions, adjust only those controls that are covered by the operating instructions. Improper adjustment of other controls may result in damage and will often require extensive work by a qualified technician to restore the CAMCORDER to its normal operation.
- e. If the CAMCORDER has been dropped or the cabinet has been damaged.
- f. When the CAMCORDER exhibits a distinct change in performance, this indicates a need for service.

20. REPLACEMENT PARTS:

When replacement parts are required, be sure the service technician has used replacement parts specified by the manufacturer and having the same characteristics as the original part.

Unauthorized substitutions may result in fire, electric shock or other hazards.

21. SAFETY CHECK:

Upon completion of any service or repairs to this CAMCORDER, ask the service technician to perform safety checks to determine that the CAMCORDER is in safe operating order.

Notices and Safety Instructions

22. To prevent damage which may result in fire or shock hazard, do not expose this appliance to rain or moisture.
23. If this power supply is used at 240V ac, a suitable plug adapter should be use.

NOTE TO CATV SYSTEM INSTALLER:

This reminder is provided to call the CATV system installer's attention to Article 820-40 of the NEC that provides guidelines for proper grounding and, in particular, specifies that the cable ground shall be connected to the grounding system of the building as close to the point of cable entry as practical.

USER INSTALLER CAUTION:

Your authority to operate this FCC certified equipment could be voided if you make changes or modifications not expressly approved by this party responsible for compliance to part 15 FCC rules.

NOTE:

"Hg LAMP(S) INSIDE THIS PRODUCT CONTAIN MERCURY AND MUST BE RECYCLED OR DISPOSED OF ACCORDING TO LOCAL, STATE OR FEDERAL LAWS"

ENGLISH**Contents****Notices and Safety Instructions****Getting to Know Your Camcorder**

Features.....	8
Descriptions	
■ Front View/Side View/Rear View	9, 10, 11
■ OSD (On Screen Display)	12
Accessories Supplied with the Camcorder.....	14
Remote Control (SCL906/L907 only).....	15
■ Self Timer Recording.....	15

Preparing

Adjusting the Hand Strap and Shoulder Strap	16
Attaching the Lens Cover	17
Lithium Battery Installation	17
Connecting the Power Source.....	18
■ To use the AC Power Adapter	18
■ To use the Battery Pack	19
Using the Battery Pack.....	20
■ Continuous Recording time table	20
■ Battery Level Display.....	21
Inserting and Ejecting a Cassette	22

Basic Recording

Making your First Recording	23
Hints for Stable Image Recording	25
■ Recording with LCD Screen	25
■ Recording with Viewfinder.....	25
Adjusting the LCD.....	26
Adjusting Focus of the VIEWFINDER	27
Playing back a tape on the LCD	28
■ Adjusting the LCD during PLAY	29
■ Controlling the Sound from the Speaker.....	29
■ Viewing a Still Picture.....	29
■ Picture Search.....	29

Advanced Recording

Zooming In and Out.....	30
Digital Zoom	31
EASY mode (for Beginners)	33
CUSTOM-Creating your own customized recording settings.....	34
DIS (Digital Image Stabilizer, SCL906/L907 only).....	35
MF/AF (Manual Focus/Auto Focus)	36
BLC.....	37

Contents (continued)

Program AE (Automatic Exposure)	38
DSE (Digital Special Effects) in CAMERA mode	40
Setting and Recording DATE/TIME	42
Selecting and Recording a Title	44
Fade In and Out	46
Snap Shot (SCL906/L907 only)	47
White Balance	48
Selecting OSD Language	49
Demonstration	50
Setting the Date/Title Color	51
Lighting Techniques	52
<i>Playing back a Tape</i>	
To watch with LCD	53
To watch with TV	53
Various Functions in PLAYER mode	55
Adjusting the LCD	56
Setting the Speaker ON/OFF	56
DSE in PLAYER mode	56
Multi Playback (Using a PAL60 System)	57
<i>USB interface (SCL907 only)</i>	
Transferring a Digital Image through a USB Connection	58
Installing USB Media 2.0 Program	59
<i>Maintenance</i>	
Cleaning and Taking care of the Camcorder	62
■ Cleaning the Viewfinder	62
■ Cleaning the LCD Panel	62
■ Cleaning the Video Heads	62
■ Storing the Camcorder	62
<i>Using Your Camcorder Abroad</i>	
63	
<i>Troubleshooting</i>	
Self Diagnosis Display	64
Checking	65
Moisture Condensation	67
<i>Specifications</i>	
68	
<i>Index</i>	
69	
<i>Warranty(SEA Users Only)</i>	
71	

ENGLISH**Notices and Safety Instructions*****Notices regarding rotation of LCD screen***

Please rotate the LCD screen carefully as illustrated.
Unintended rotation may cause damage to the inside of the hinge that connects the LCD screen to the Camcorder.

- 1) LCD screen closed.
- 2) Standard recording by using the LCD screen.
- 3) Making a recording by looking at the LCD screen from the top.
- 4) Making a recording by looking at the LCD screen from the front.
- 5) Making a recording with the LCD screen closed.

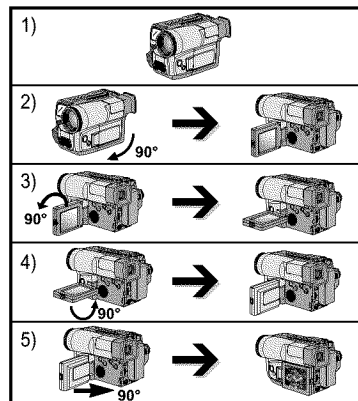
***Notices regarding the LENS***

- ❖ Do not let the LENS point toward the sun.
Direct sunlight can damage the CCD (Charge Coupled Device).

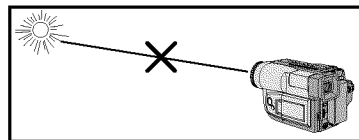

Notices and Safety Instructions

Notices regarding electronic viewfinder

- 1) Do not place the camcorder so that the viewfinder is pointing towards the sun. Direct sunlight can damage the inside of the viewfinder. Be careful when placing the camcorder under sunlight or by a window.
- 2) Do not pick up the camcorder by the viewfinder.
- 3) Unintended rotation may cause damage to the viewfinder.

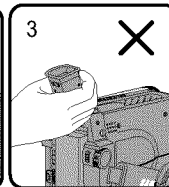
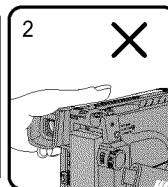
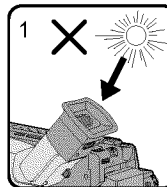

Notices regarding moisture condensation

- 1) A sudden rise in atmospheric temperature may cause condensation to form inside the camcorder.

for example:

- When you take the camcorder from cold temperature outside to warm temperature inside during the winter.
 - When you take the camcorder from cool temperature inside to hot temperature outside during the summer.
- 2) If the "DEW([])" protection feature is activated, leave the camcorder in a dry, warm room with the cassette compartment opened and the battery removed.
 - 3) If the "DEW([])" protection feature is activated unexpectedly, and you want to override it, detach, then reinstall the battery pack and lithium battery. Please make sure that the condensation has disappeared completely. (see page 67)



ENGLISH**Notices and Safety Instructions****Notices regarding the battery pack**

- ❖ Make sure that the battery pack is charged before recording outdoors.
- ❖ To preserve battery power, keep your camcorder turned off when you are not operating it.
- ❖ When your camcorder is in CAMERA mode, if it is left in STANDBY for more than 5 minutes without operation, it will automatically turn off to protect against unexpected battery discharge.
- ❖ It is a good idea to use the viewfinder instead of the LCD when recording for a long time because the LCD uses more battery power.
- ❖ Make sure that the battery pack is fitted firmly into place. Dropping the battery pack might damage it.
- ❖ When the battery reaches the end of its life, please contact your local dealer. The batteries have to be dealt with as chemical waste.

Notices regarding the Lithium battery

Warning: Keep the LITHIUM BATTERY out of the reach of children. Should the battery be swallowed, consult a doctor immediately.

- ❖ The lithium battery maintains the CLOCK function, TITLE, CUSTOM function and preset contents memory; even if the battery pack or AC power adapter is removed.
- ❖ The lithium battery for the camcorder lasts about 8~10 months under normal operation from time of installation.
- ❖ When the lithium battery becomes weak or dead, the date/time indicator flashes about 5 seconds when you set the power switch to CAMERA. When this occurs, replace the lithium battery with type CR2025. (see page 17)

WARNING:

LITHIUM BATTERY MUST BE RECYCLED OR DISPOSED OF PROPERLY.



* When the lithium battery becomes weak or dead please contact your local dealer. The batteries have to be dealt with as chemical waste.

Notices and Safety Instructions

Notices with Recording or Playback by using LCD

- 1) The LCD Screen is manufactured by using high precision technology. However, there may be some tiny specks (red, blue or green in color) that appear on the LCD Screen. These specks are normal and do not affect the recorded picture in any way.
- 2) When using the LCD Screen outdoors in direct sunlight, it may be difficult to view. If this occurs, use the viewfinder.
- 3) The LCD Screen's OSD is turned off when the LCD is placed in the forward direction.



Notices regarding the hand strap

- ❖ It is very important to adjust the hand strap for better recording. (see page 16)
- ❖ Do not insert your hand in the hand strap forcibly, the buckle may be damaged.

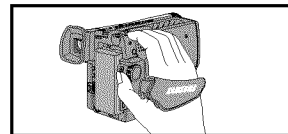

Notices regarding video head cleaning

- ❖ To ensure normal recording and clear picture, clean the video heads. When playing back the pictures, if they are noisy or hardly visible, the video heads may be dirty. If this happens, clean the video heads with a dry type cassette cleaner.
- ❖ Do not use a wet type cassette cleaner. It may damage the video heads. (see page 62)

5 minutes off timer in STANDBY mode

- ❖ To protect against tape and head-drum wear, your camcorder will automatically turn off if it is left in STANDBY mode without operation for more than 5 minutes.

ENGLISH**Getting to Know Your Camcorder****Features**

Your camcorder has many features for recording and playing back.

MULTI OSD LANGUAGE

You can select the appropriate OSD Language among English, French, Spanish.

Snap Shot (SCL906/L907 only)

The Snap Shot function lets you record an object at a standstill for a limited time in Camera mode. (see page 47)

BLC

When you record a subject with the light source behind the subject or a subject with a light background, use the BLC function. (see page 37)

DSE (Digital Special Effects)

The DSE enables you to give a creative look to your films by adding various special effects. (see page 40)

Program AE (Auto Exposure)

The Program AE enables you to adapt the shutter speed and aperture to the type of scene to be filmed. (see page 38)

DIS (SCL906/L907 only)

The DIS compensates for unstable images caused by hand shake, particularly at high magnification. (see page 35)

22x High ratio zoom lens

Zooming is a recording technique that lets you change the size of the subject in the picture. For more professional recordings, use the zoom function. (see page 30)

Digital Zoom (880x)

Zooms more than 22x are performed digitally. (see page 31)

Macro

The macro function allows you to record your subject at close range. You have to adjust the zoom fully wide for macro recording. (see page 30)

EASY

This mode enables even the beginner to easily make a recording. (see page 33)

Multi PLAYBACK (PAL60)

PAL60 is a special output signal format with which a PAL TV can be used to view a tape recorded by an NTSC recorder.

Getting to Know Your Camcorder

Front View

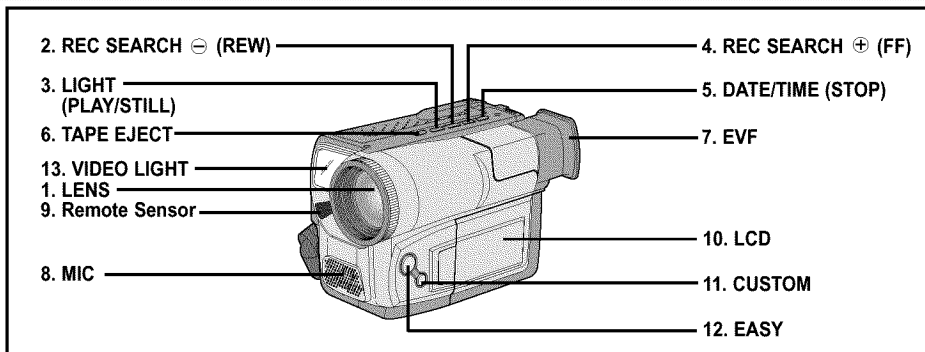

- 1. Lens** (see page 68)
- REC SEARCH \ominus (REW)**
REC SEARCH \ominus works in STANDBY mode. (see page 24)
REW works in PLAYER mode. (see page 55)
- LIGHT (PLAY/STILL)** (see page 54)
PLAY/STILL works in PLAYER mode.
LIGHT works in CAMERA mode. (SCL906/L907 only)
The built-in video light turns on when LIGHT is pressed.
It enables recording in low-light conditions.
- REC SEARCH \oplus (FF)**
REC SEARCH \oplus works in STANDBY mode. (see page 24)
FF works in PLAYER mode. (see page 55)
- DATE/TIME (STOP)**
DATE/TIME works in CAMERA mode. (see page 42)
STOP works in PLAYER mode. (see page 54)
- TAPE EJECT** (see page 22)
Use when ejecting the tape.
- EVF (Electronic Viewfinder)**
- MIC**
MIC works in CAMERA mode.
- Remote Sensor (SCL906/L907 only)**
- LCD** (see page 26)
- CUSTOM**
CUSTOM works in CAMERA mode.
- EASY**
EASY works in CAMERA mode.
- VIDEO LIGHT (SCL906/L907 only)**

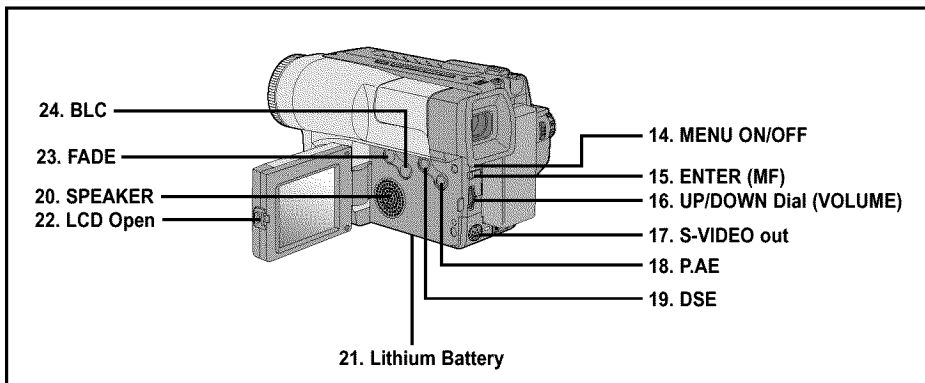
ENGLISH**Getting to Know Your Camcorder***Side View*

- 14. MENU ON/OFF (see page 26)**
MENU ON/OFF works in CAMERA and PLAYER mode.
- 15. ENTER (MF) (see page 26)**
ENTER works in MENU mode.
MF works in CAMERA mode. (see page 36)
- 16. UP/DOWN dial (VOLUME)**
UP/DOWN dial works in MENU mode. (see page 26)
VOLUME works in PLAYER mode. (see page 56)
- 17. S-VIDEO out (see page 54)**
- 18. PROGRAM AE (see page 38)**
PROGRAM AE (Auto Exposure) works in CAMERA mode.

- 19. DSE (see page 40)**
DSE works in CAMERA and PLAYER mode.
- 20. SPEAKER (see page 56)**
Speaker works in PLAYER mode.
- 21. Lithium Battery (see page 17)**
- 22. LCD open**
- 23. FADE (see page 46)**
FADE works in CAMERA mode.
- 24. BLC (see page 37)**
BLC works in CAMERA mode.

Getting to Know Your Camcorder

Rear View

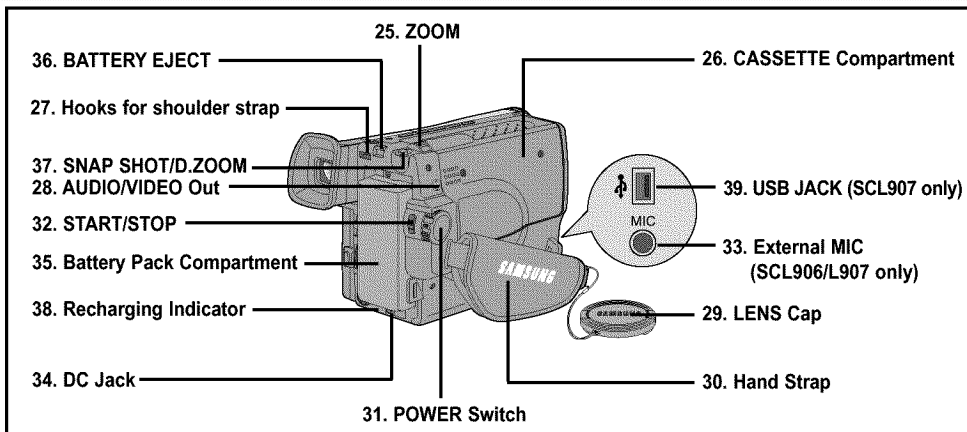

25. ZOOM (see page 30)

26. Cassette Compartment

27. Hooks for Shoulder Strap (see page 17)

28. AUDIO/VIDEO out (see page 53)

29. LENS Cap

30. Hand Strap (see page 16)

31. POWER Switch (see page 18)

- CAMERA : Select to record.
- OFF : Select to turn off the camcorder.
- PLAYER : Select to playback.

32. START/STOP (see page 23)

START/STOP works in CAMERA mode.

33. External MIC (see page 68) (SCL906/L907 only)

34. DC Jack (see page 18)

35. Battery Pack Compartment (see page 19)

36. BATTERY EJECT

37. SNAP SHOT/D.ZOOM

SNAP SHOT works in CAMERA mode.

(SCL906/L907 only, see page 47)

D.ZOOM works in CAMERA mode.

(SCL901 only, see page 32)

38. Recharging Indicator (see page 19)

39. USB Jack (SCL907 only) (see page 61)

ENGLISH**Getting to Know Your Camcorder****OSD (On Screen Display)**

- ❖ You can turn the OSD on/off by setting the Display menu on/off.
- ❖ The TITLE, DATE/TIME, EASY and CUSTOM functions can be operated even after the OSD is turned off.
- ❖ The OSD is displayed in the viewfinder and the LCD Screen.

a. Zoom position (see page 30)

Indicates zoom position.

b. DIS (SCL906/L907 only) (see page 35)

Indicates DIS is activated.

c. Battery level (see page 21)

Indicates the power left in the battery.

**d. Manual Focus (see page 36)**Indicates manual focus is on.
Auto Focus is not displayed.**e. BLC (see page 37)**

Indicates BLC is activated.

f. Program AE (see page 38)

Indicates Program AE mode is activated. (📷, 📷, 📷, 📷, 📷)

g. Self record waiting timer. (SCL906/L907 only) (see page 15)

Indicates 10 second timer.

h. Self record recording timer. (SCL906/L907 only) (see page 15)

(30 seconds or END).

i. Date (see page 42)

Indicates the date of the recording.

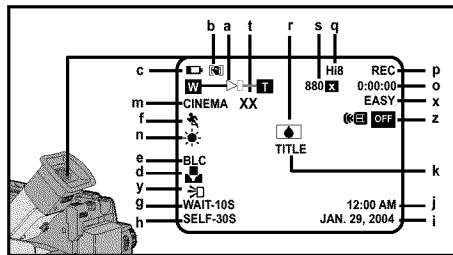
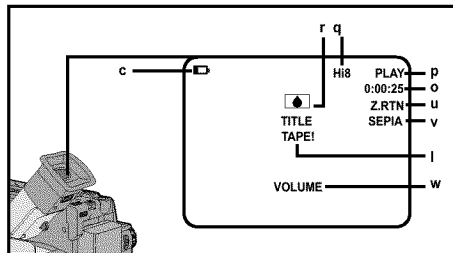
OSD in CAMERA mode**OSD in PLAYER mode**

Getting to Know Your Camcorder

OSD (On Screen Display)

- j. **Time (see page 42)**
Indicates the time you are recording.
- k. **Title (see page 44)**
Indicates the recorded title you have set. It is superimposed on the scene.
- l. **Self diagnosis (see page 64)**
(TAPE!, TAPE END!, PROTECTION!) Checks the operation of the Camcorder.
- m. **DSE (Digital Special Effect) (see page 40)**
Indicates the DSE mode is activated.
The operation modes are STROBE, SEPIA, B&W, NEG., MIRROR, ART, MOSAIC, 16:9(WIDE) and CINEMA.
- n. **White Balance mode (see page 48)**
Indicates the White Balance mode is activated.
The White Balance modes are AUTO, INDOOR (☀) and OUTDOOR (☀).
- o. **Tape counter**
Indicates amount of the tape used.
- p. **Operation mode**
Indicates the operation mode is activated.
The operation modes are STBY, REC (●), STOP, PLAY (▶), FF (▶▶), REW (◀◀), EJECT.
- q. **Hi8 (see page 54)**
Indicates you are using Hi8 tape when recording or playing back.
- r. **DEW (☐) condensation (see page 67)**
Monitors the moisture condensation.
- s. **Digital zoom (see page 31)**
Indicates digital zoom is activated.
- t. **Snap Shot (SCL906/L907 only) (see page 47)**
Indicates the time left during Snap Shot Recording.
- u. **Zero return (SCL906/L907 only) (see page 55)**
Indicates that the zero return is activated.
- v. **PB DSE (see page 56)**
Shows that the PB DSE mode is active.
- w. **VOLUME (see page 56)**
- x. **EASY & CUSTOM**
Shows when the easy or custom mode is active.
- y. **LIGHT (SCL906/L907 only)**
Shows when the Light is switched on.
- z. **Remocon (☐ OFF) (SCL906/L907 only)**
Indicates the remocon off mode is activated.

ENGLISH**Getting to Know Your Camcorder****Accessories Supplied with Camcorder**

Make sure that the following basic accessories are supplied with your camcorder.











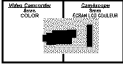

Basic Accessories

1. AC Power Adapter. (AA-E8 TYPE) (see page 18)
2. AC cord. (see page 18)
3. Battery Pack. (see page 19)
4. Audio/Video Cable. (see page 53)
5. Shoulder strap. (see page 17)
6. Instruction Book.
7. Remote Control. (see page 15) (SCL906/L907 only)
8. Lithium Battery for Remote Control. (see page 15)
(SCL906/L907 only)
Lithium Battery for Clock. (TYPE: CR2025, see page 17)
9. Software CD (SCL907 only)
10. USB Cable (SCL907 only)
11. USB AUDIO Cable (SCL907 only)
12. Lens Cover

Optional Accessory

13. S-VIDEO cable. (see page 54)

Note: Optional accessories may be included with the camcorder, depending on the country in which it is purchased.

1. AC Power Adapter (AA-E8 TYPE)  AD44-00090A	2. AC cord  AD39-00076A	3. Battery Pack  AD43-00065A
4. AUDIO/VIDEO Cable  AD39-40200A	5. Shoulder Strap  AD72-00054A	6. Instruction Book 
7. Remote Control  AD59-00062A	8. Lithium Batteries  AD43-10130H	9. Software CD  AD46-00060A
10. USB Cable  AD39-00073A	11. USB AUDIO Cable  AD39-00098A	12. Lens Cover  AD97-08362A
13. S-VIDEO cable  AC39-42001Z		

Getting to Know Your Camcorder

Remote Control (SCL906/L907 only)

Description of Buttons

1. Start/Stop (see page 23)
2. Self Timer
3. Still (see page 55)
4. WIDE (see page 30)
5. TELE (see page 30)
6. Display (see page 12)
7. ► (Play) (see page 54)
8. ►► (FF) (see page 55)
9. ◀◀ (REW) (see page 55)
10. ■ (Stop) (see page 54)
11. Counter Reset (see page 55)
12. Zero Return (see page 55)

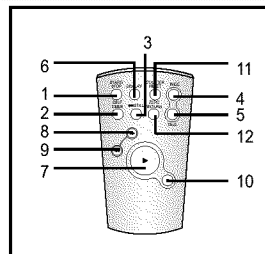

Remote Control Battery Installation

- ❖ You must insert or replace this battery when:
 - You purchase the camcorder.
 - The remote control doesn't work.
- ❖ Insert Lithium Battery, following the + and - markings.
- ❖ Be careful not to reverse the polarity of the battery.

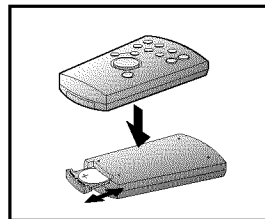

Self Timer Recording

- ❖ The Self Timer function on the remote control allows you to start and stop recording automatically.

Example: Recording yourself

- ❖ Two options are available
 - WAIT-10S/SELF-30S: wait 10 seconds, followed by 30 seconds of recording.
 - WAIT-10S/SELF-END: wait 10 seconds, followed by recording until you press the START/STOP button again.

ENGLISH**Preparing**

1. Set power switch to CAMERA mode.
2. Press Self Timer button until the appropriate indicator is displayed on the LCD:
 - WAIT-10S/SELF-30S
 - WAIT-10S/SELF-END
3. Press START/STOP button to start the timer.
 - : After waiting for 10 seconds, recording starts.
 - : If you have selected SELF-30S, recording stops automatically after 30 seconds.
 - : If you have selected SELF-END, press START/STOP again when you wish to stop recording.

Note: When recording with the timer, you can press START/STOP button again to cancel the function.

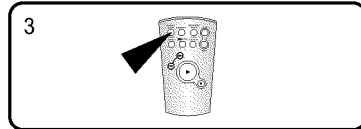
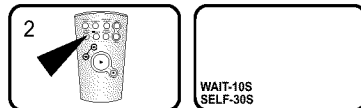
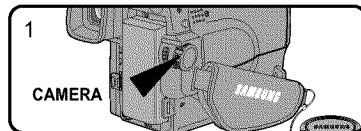
**Adjusting the Hand Strap and Shoulder Strap****Hand Strap**

- ❖ It is very important to adjust the hand strap for better recording.
- ❖ The hand strap enables you to:
 - Hold the camcorder in a stable, comfortable position.
 - Press the Zoom and the red Record button without having to change the position of your hand.

1. Pull open the Hand Strap cover and release the Hand Strap, adjust its length and stick it back onto the Hand Strap cover.
2. Close the Hand Strap cover back up again.

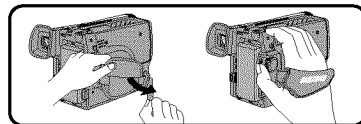
**Shoulder Strap**

- ❖ The Shoulder Strap allows you to carry your camcorder with complete safety.
1. Insert each end of the strap into the hooks on the camcorder.
 2. Put the end of each strap through the buckle, adjust the length of the strap, then pull it tight in the buckle.

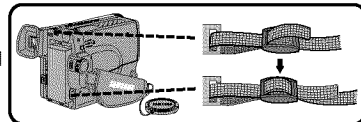

Preparing

Attaching the Lens Cover

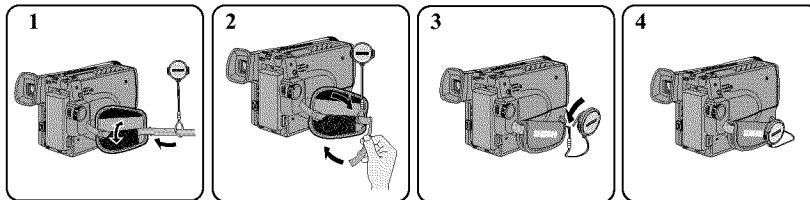

Lithium Battery Installation

- ❖ The lithium battery maintains the clock function, title and preset contents of the memory; even if the battery pack or AC power adapter is removed.
- ❖ The lithium battery for the camcorder lasts about 8~10 months under normal operation from the time of installation.
- ❖ When the lithium battery becomes weak or dead, the date/time indicator flashes for about 5 seconds when you set the power switch to CAMERA.
When this occurs, replace the lithium battery with type CR2025.

1. Take out the holder from the lithium battery compartment.
2. Insert the ⊕ side of the lithium battery toward the bottom of the holder.
3. Reinsert the holder into the lithium battery compartment.

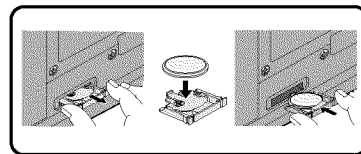

Note: If the holder is inserted in the wrong direction, it will not fit correctly.

Warning: Keep the LITHIUM BATTERY out of the reach of the children.
Should the battery be swallowed, consult a doctor immediately.

ENGLISH**Preparing****Connecting the Power Source**

- ❖ There are two ways to connect power source.
 - Using the AC Power Adapter : used for indoor recording.
 - Using the Battery Pack: used for outdoor recording.

To use the AC Power Adapter

1. Connect the AC Power Adapter to the AC cord.
2. Connect the AC cord to a wall socket.

Note: The plug and wall socket type may be different depending on regional conditions.
3. Connect the other end of the DC cable to DC jack of the camcorder.
4. To set the camcorder to the CAMERA mode.
 - a. Hold down the tab of the power switch and push the switch to CAMERA mode.
 - b. Make sure that the Lens Cap is open.
 - c. Open the LCD Screen and make sure that the image appears in the LCD Screen.
 - The LCD Screen is turned on automatically when it's opened more than 30 degrees.

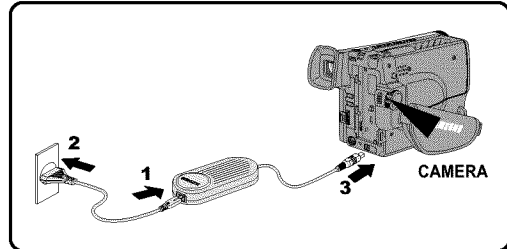

Note: If the adapter is used next to a TV or the camcorder, it may cause the TV or camcorder to emit noise. Move the adapter away from the TV, camcorder or the antenna cable.

Preparing

To use the Battery Pack

How long will the battery last for recording?

- ❖ Depends on how often you are likely to use the zoom feature during recording.

Recharging the Battery Pack

1. Attach the battery pack to the camcorder.
2. Connect the AC Power Adapter to the AC cord and connect the AC cord to a wall socket.
3. Connect the DC cable to the DC jack of the camcorder.
4. Turn off the camcorder power, and the recharging indicator will start blinking and begin recharging.
 - Blinking once a second : Indicates less than 50% has been charged.
 - Blinking twice a second : Indicates 50% ~ 75% has been recharged.
 - Blinking three times a second : Indicates 75% ~ 100% has been recharged.
 - Blinking stops and stays on : Recharging has been completed.
 - On for a second and off for a second: Indicates there is an error. Reset the battery pack and DC cable.
5. If recharging is completed, separate the camcorder, AC power adapter, and battery pack.
 - Even if the power is turned off, battery will be discharged.

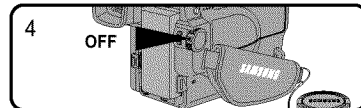
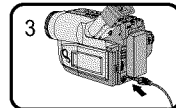
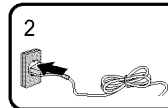
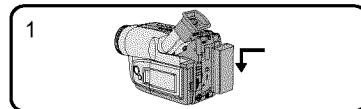

Note: Battery pack may be charged a little at the time of purchase.

ENGLISH

Preparing

Using the Battery Pack

Continuous recording time table based on model and battery type.

Battery Type	LCD ON, EVF OFF	LCD OFF, EVF ON
SB-L110A	Approximately 90 minutes	Approximately 120 minutes
SB-L160	Approximately 130 minutes	Approximately 180 minutes
SB-L320	Approximately 270 minutes	Approximately 360 minutes

- ❖ The continuous recording times given in the table are approximate. Actual recording time depends on usage.

Notes:

- ❖ The battery pack should be recharged in a room temperature that is between 0°C(32°F) and 40°C(104°F). It should never be charged in a room temperature that is below 0°C(32°F).
- ❖ The life and capacity of the battery pack will be reduced if it is used in temperatures below 0°C, even when it is fully recharged.
- ❖ The life and capacity of the battery pack will be reduced if the battery pack is left in temperatures above 40°C(104°F) for a long period, even when it is fully recharged.
- ❖ Do not put the battery pack near any heat source (fire or flames, for example).

Preparing

Battery Level Display

❖ The battery level display indicates the amount of power remaining in the battery pack.

1. Fully charged
2. 10~40% consumed
3. 40~60% consumed
4. 60~80% consumed (prepare a charged one)
5. 80~95% consumed (change the battery)
6. 100% consumed
(camcorder will turn off soon, change the battery as soon as possible)

❖ Please refer to the table on page 20 for approximate continuous recording time.

❖ The recording time is affected by environmental temperature and conditions.

The recording time becomes very short in a cold environment.

The continuous recording time in the operating instructions is measured under the condition of using a fully charged battery pack at 25°C(77°F). As the environmental temperature and conditions may be different when you actually use the camcorder, the remaining battery time may not be the same as the approximate continuous recording times given in these instructions.

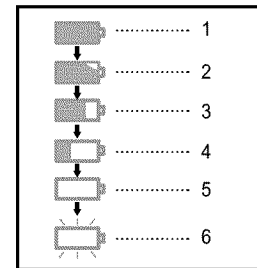

Tips for Battery Identification.

A charge mark is provided on the battery pack to help you remember whether it has been charged or not.

Two colors are provided (red and black) you may choose which one indicates charged and which indicates discharged.

Note: The charge mark does not affect the battery's charge status.

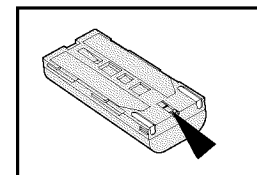

ENGLISH**Preparing*****Inserting and Ejecting a Cassette***

- ❖ There are several cassette types, depending on:
 - Color system used
 - Recording/playback time.
 - Hi8

Inserting and Ejecting a Cassette

- ❖ Check to see if the battery pack is in place or AC adapter is connected.
Make sure the A/V cable is unplugged.

1. **Press the EJECT button.**
 - The compartment opens automatically.
 - Insert the cassette with the transparent window facing outward and the protection tab toward the top.
2. **Press the PUSH mark until the compartment clicks into place.**

Note: When you have recorded a cassette that you wish to keep, you can protect it from being accidentally erased.

- a. **Recording Impossible (Protection):**
Push the red tab on the cassette to cover up the opening.
- b. **Recording possible:**
If you no longer wish to keep the recording on the cassette, push the red tab back so that it no longer covers up the opening.

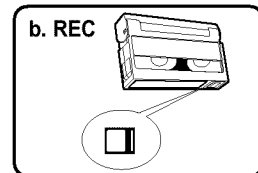
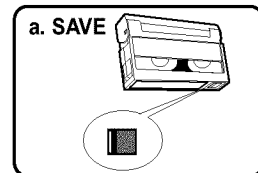
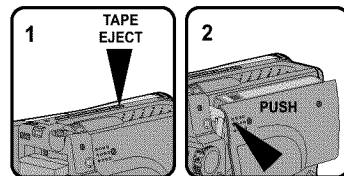

Basic Recording

Making Your First Recording

Please make these preparations before recording.

- Did you connect a power source? (Battery Pack or AC Power Adapter)

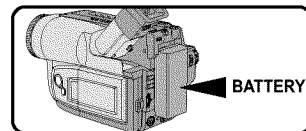

- Did you set the power switch to CAMERA position?

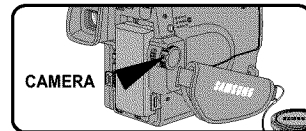

- Did you insert a cassette? (see page 22)
- Open the LCD Screen and make sure that STBY is displayed on the LCD (if the red tab of the cassette is opened, STBY will not be displayed)
- Did you open the LENS CAP?
- Make sure the image you want to record appears in the LCD monitor.
- Make sure the battery level indicates that there is enough remaining power for recording. (see page 21)
- We recommend that beginners, who are using the camcorder for the first time, switch the EASY mode on. (see page 33)

- To start recording, press the red START/STOP button.
Recording starts and REC should be displayed on the LCD.

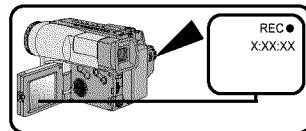

ENGLISH**Basic Recording**

- b. To stop recording, press the red START/STOP button again.
When Recording stops, STBY should be displayed on the LCD.

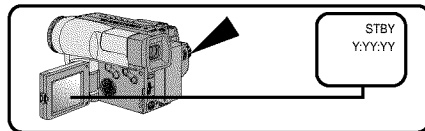

When a cassette is loaded and the camcorder is left in STANDBY mode for over 5 minutes without being used, it will turn off automatically. To use it again, push the red START/STOP button or set the power switch to OFF and then back to CAMERA. This Auto Power Off feature is designed to save battery power and to protect the Head Drum and tape.

REC SEARCH

- ❖ You can view a recorded picture with the REC SEARCH \oplus , \ominus function in STANDBY mode. REC SEARCH \ominus allows you to reverse and REC SEARCH \oplus allows you to forward, for as long as you keep pressing.
- ❖ If you press the REC SEARCH \ominus button briefly in STANDBY mode, your camcorder will play back in reverse for 3 seconds and return to the original position automatically.

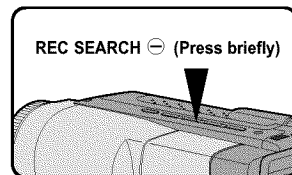
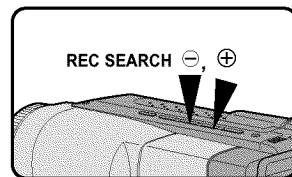

Basic Recording

Hints for Stable Image Recording

- While recording, it is very important to hold the camcorder correctly.
- For stable recording, fix the LENS COVER firmly by clipping it on the hand strap. (refer to figure)

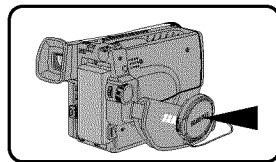

Recording with the LCD Screen

1. Hold the camcorder firmly using the hand strap. (see page 16)
2. Place your right elbow against your side.
3. Place your left hand under or next to the LCD to support and adjust it. Do not touch the built-in microphone.
4. Choose a comfortable, stable position for the shots that you are taking. You can lean against a wall or on a table for greater stability. Do not forget to breathe gently.
5. Use the LCD frame as a guide to determine the horizontal plane.
6. Whenever possible, use a tripod.



Recording with the Viewfinder

1. Hold the camcorder firmly with the hand strap. (see page 16)
2. Place your right elbow against your side.
3. Place your left hand under the camcorder to support it. Do not touch the built-in microphone.
4. Choose a comfortable, stable position for the shots. You can lean against a wall or on a table for greater stability. Do not forget to breathe gently.
5. Put your eye firmly against the eyecap.
6. Use the viewfinder frame as a guide to determine the horizontal plane.
7. Whenever possible, use a tripod.



ENGLISH**Basic Recording****Adjusting the LCD**

- ❖ Your camcorder is equipped with a 2.5 inch color Liquid Crystal Display (LCD) screen, which allows you to view recording or play-back directly.
 - ❖ Depending on the conditions in which you are using the camcorder (indoors or outdoors for example), you can adjust:
 - Brightness
 - Color
1. Make sure that the battery pack is in place.
 2. Set the power switch to CAMERA mode. (see page 18)
 3. Open the LCD Screen, then the LCD will turn on.
 4. Press the MENU ON/OFF button, the MENU list will be displayed.
 5. Turn the UP/DOWN dial to LCD ADJUST.
 6. Press ENTER.
 - The LCD ADJUST MENU will be displayed.
 7. Turn the UP/DOWN dial to adjust the LCD brightness.
 8. Press ENTER.
 - The cursor will move to the next item.

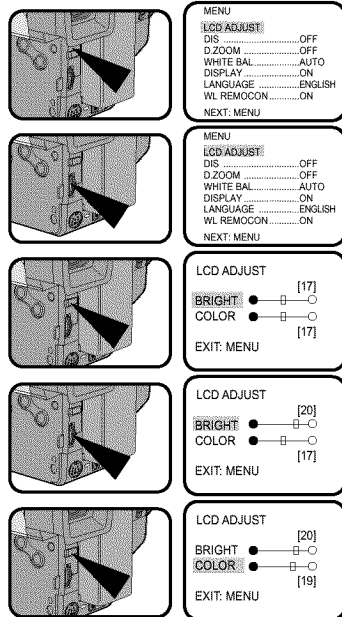

Basic Recording

9. Turn the UP/DOWN dial to adjust the LCD color setting.

10. Press ENTER.

- For further adjustment, repeat steps 7, 8, 9.

11. Press the MENU ON/OFF button to end the setting.

- Note:**
- If you do not press a button within 30 seconds, the setting will disappear.
 - The MENU ON/OFF function will not operate in EASY mode.

Adjusting Focus of the VIEWFINDER

Focus:

Use the focus adjustment knob of the VIEWFINDER to focus the picture.

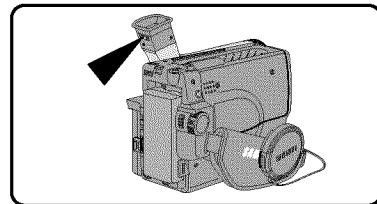

ENGLISH**Basic Recording*****Playing back a tape on the LCD***

- ❖ You can monitor the playback picture on the LCD Screen.
- ❖ Make sure that the battery pack is in place.

1. Hold down the tab of the power switch and push the switch to PLAYER mode.
2. Insert the tape you have just recorded.
3. Open the LCD Screen and make sure that STOP is displayed on the OSD. Adjust the angle of the LCD Screen and set the brightness or the color if necessary.
4. Press the ◀◀ (REW) button to rewind the tape to the beginning.
 - To stop REWIND, press the ■ (STOP) button.
 - Camcorder stops automatically after rewinding.
5. Press the ▶▶ (PLAY/STILL) button to start playback.
 - You can see the video you recorded on the LCD.
 - To stop the PLAYBACK operation, press the ■ (STOP) button.

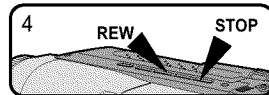
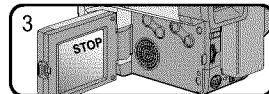
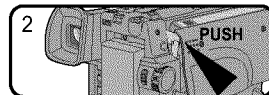

Note: You can also monitor the picture on a TV screen, after connecting the camcorder to a TV or VCR. (see page 53)

Basic Recording

Adjusting the LCD during PLAY

The LCD adjustment method in PLAYER mode is identical to step number 4 of page 26, except the power switch must be set to PLAYER.

Controlling the Sound from the Speaker

- ❖ When you use the LCD Screen while playing back, you can hear sound from the Speaker.
- ❖ Volume of the Speaker is controlled by the UP/DOWN dial tab on the camcorder.
- ❖ If you close the LCD Screen, the LCD Screen and Speaker are turned off.
- ❖ If the speaker does not work properly, check the following:
 - Is the LCD Screen closed?
 - Is the volume adjusted to a low level?
 - Is the speaker off? (see page 56)

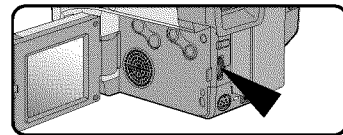

- Notes:**
- Lower the volume if vibration from the built-in speaker causes screen disturbance.
 - Volume display will automatically disappear 2 seconds after adjusting.

Viewing a Still Picture

- Press **▶||** (PLAY/STILL) button during playback.
- To resume playback, press the **▶||** (PLAY/STILL) button again.

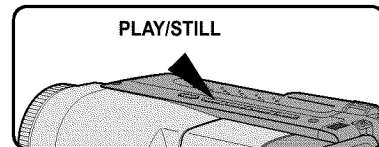

Picture Search

- Keep pressing **▶▶** (FF) or **◀◀** (REW) button during playback.
- To resume normal playback, release the button.

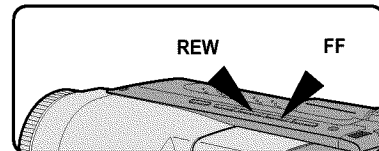

ENGLISH**Advanced Recording****Zooming In and Out**

- ❖ Zoom works in CAMERA mode only.
- ❖ Zooming is a recording technique that lets you change the size of the subject in the picture. For more professional looking recordings, do not use the zoom function too often.
- ❖ You can also choose from two zoom speeds to suit different needs :
 - Gradual zoom (9~12 seconds from TELE/WIDE to WIDE/TELE)
 - High-Speed zoom (3~6 seconds from TELE/WIDE to WIDE/TELE)
- ❖ Use these features for different shots; please note that overuse of the zoom feature can lead to unprofessional looking results and a reduction of battery pack usage time.

1. Move the zoom lever a little for a gradual zoom, move it further for a high-speed zoom.
Your zooming is monitored on the OSD.

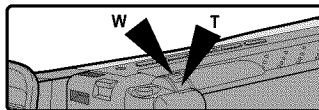

2. T (Telephoto) side:
Subject appears closer.

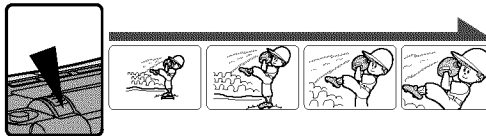

3. W (Wide angle) side:
Subject appears further away.

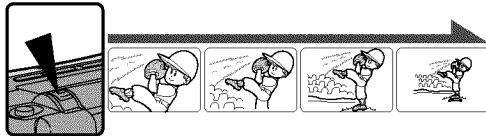
**Note: MACRO**

If you cannot obtain sharp focus in telephoto zoom, move the lever to the "W" side until the focus sharpens.
You can record a subject that is at least 1 mm away from the lens surface in the wide angle position.

Advanced Recording

Digital Zoom

- ❖ Digital Zoom works in CAMERA mode only.
- ❖ Zooms more than 22x are performed digitally.
- ❖ The picture quality deteriorates as you go towards the "T" side.
- ❖ We recommend that you use the DIS (SCL906/L907) feature with the DIGITAL ZOOM for picture stability. (see page 35)

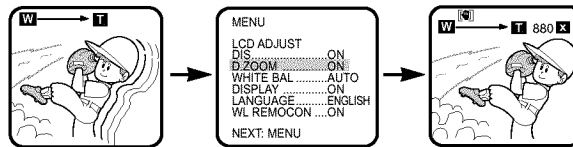

1. Set the power switch to CAMERA mode. (see page 18)
 - Open the LCD Screen and adjust the LCD Screen so as to see comfortably.
2. Make sure that the DIGITAL ZOOM feature is on. (see page 32)
3. When you move the ZOOM lever to the "T" side, the picture will be enlarged within 22x minimum to 880x maximum ZOOM. This is the DIGITAL ZOOM boundary.



- shows the digital zoom area
- shows the optical zoom area

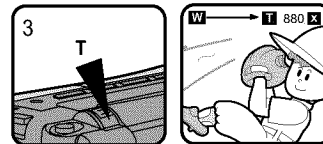

4. If you do not want to use the DIGITAL ZOOM, set the D.ZOOM function to OFF in the MENU list. (see page 32)

ENGLISH**Advanced Recording****Setting the DIGITAL ZOOM ON/OFF (SCL906/L907 only)**

❖ The DIGITAL ZOOM feature is explained on page 31.

1. Set the power switch to CAMERA mode. (see page 18)
2. Press the MENU ON/OFF button.
 - The MENU list will appear.
3. Turn the UP/DOWN dial to D. ZOOM.
4. Press ENTER.

 - The DIGITAL ZOOM setting will change.

5. Press the MENU ON/OFF button to end setting.

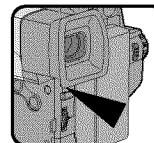

MENU
 LCD ADJUST
 DIS OFF
 D.ZOOM OFF
 WHITE BAL AUTO
 DISPLAY ON
 LANGUAGE ENGLISH
 WL REMOCON ON
 NEXT: MENU

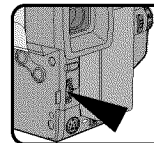

MENU
 LCD ADJUST
 DIS OFF
 D.ZOOM OFF
 WHITE BAL AUTO
 DISPLAY ON
 LANGUAGE ENGLISH
 WL REMOCON ON
 NEXT: MENU

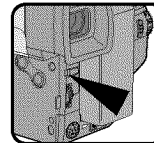

MENU
 LCD ADJUST
 DIS OFF
 D.ZOOM ON
 WHITE BAL AUTO
 DISPLAY ON
 LANGUAGE ENGLISH
 WL REMOCON ON
 NEXT: MENU

Setting the DIGITAL ZOOM ON/OFF (SCL901 only)

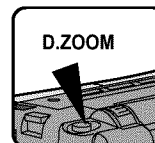

1. Set the power switch to CAMERA mode.
 - Power switch will be changed to CAMERA mode.
2. Press D. ZOOM ON/OFF button.
 - The DIGITAL ZOOM indicators will be displayed on the screen, and DIGITAL ZOOM function will operate.
3. To deactivate the DIGITAL ZOOM function, press the D.ZOOM button again.
 - The DIGITAL ZOOM indicators disappear from the screen.



Note: The D.ZOOM ON/OFF function will not operate in EASY mode.

Advanced Recording

EASY Mode (for Beginners)

- ❖ Even a beginner can easily make a recording using the EASY mode.
 - The EASY mode only operates in CAMERA mode.
1. Set the power switch to CAMERA mode (see page 18).
 2. By pressing the EASY button, all the functions of the camera will be set to off and the recording settings will be set to the following basic mode.
 - Battery level, recording mode, counter, date/time, DIS () will be displayed as the camcorder starts to run.
 - The word "EASY" will appear on the LCD at the same time. However, the Date/Time will only be seen if it has been previously set. (DIS () will be displayed on SCL906/L907 only)
 3. Press the START/STOP button to start recording.
 - Recording will begin using the basic automatic environment settings.
 4. Pressing the EASY button again turns the EASY mode off.
 - The camera will return to the settings that were set prior to the EASY mode being switched on.

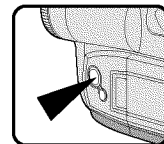
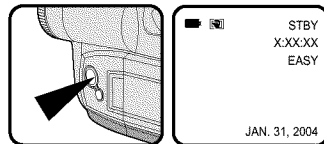

Notes:

- In the EASY mode, the MENU, MF, DSE, PAE and BLC functions are not available.
- If you want to use these functions, you must first switch the EASY mode off.
- The EASY mode settings are stored in the camera (provided a good lithium battery has been installed).

ENGLISH**Advanced Recording****CUSTOM - Creating your own customized recording settings**

- ❖ You can customize the settings and save them for future use.
 - The CUSTOM function only operates in CAMERA mode.

1. Set the power switch to CAMERA mode. (see page 18)
2. Press the MENU ON/OFF button, to bring up the MENU list.
3. Turn the UP/DOWN dial until CUSTOM SET is highlighted.
4. Press the ENTER button, the CUSTOM menu will appear.
 - Set the status of each item to what you want.
5. To exit the menu, press the MENU ON/OFF button twice.
6. By pressing the CUSTOM button, the custom settings will come up.
 - Date/Time and Title will only appear if these have been set in advance.
 - The word "CUSTOM" will be displayed on the LCD at the same time.

Example: When the CUSTOM SET is set as follows;

7. Press the START/STOP button to start recording.
 - Recording will begin using the new CUSTOM settings.
8. To switch Custom off, press the CUSTOM button once.
 - The camera will revert to the settings that were set prior to the CUSTOM mode being switched on.

Note:

- The CUSTOM settings will be stored in the camera (providing a good lithium battery has been installed).

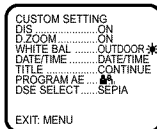
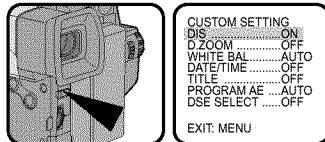
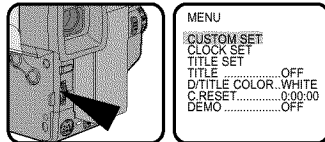
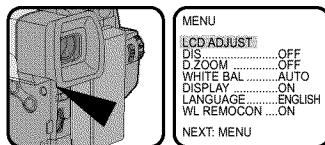

Pressing the
CUSTOM button,
displays

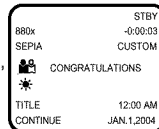

Advanced Recording

DIS (Digital Image Stabilizer, SCL906/L907 only)

- ❖ The DIS function works in CAMERA mode only.
- ❖ DIS (Digital Image Stabilizer) is a handshake compensation function that compensates for any shaking or moving of the hand holding the camcorder (within reasonable limits).
- ❖ It provides more stable pictures when:
 - Recording in the Zoom In mode
 - Recording a small object close-up
 - Recording and walking at the same time
 - Recording through the window of a vehicle

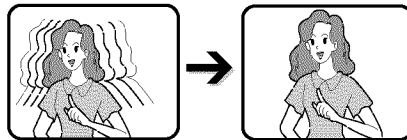

1. Set the power switch to CAMERA mode. (See page 18)
 - Open the LCD Screen and adjust it to see comfortably.
2. Press the MENU ON/OFF button.
 - The MENU list will appear.
3. Turn the UP/DOWN dial to DIS.
4. Press ENTER.
 - The DIS setting will change.
5. Press the MENU ON/OFF button to end the setting.
 - When the DIS is set, the DIS mark (DIS) will be displayed on the OSD.

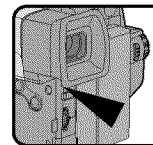

LCD ADJUST
 DIS OFF
 D.ZOOM OFF
 WHITE BAL AUTO
 DISPLAY ON
 LANGUAGE ENGLISH
 WL REMOCON ON
 NEXT: MENU

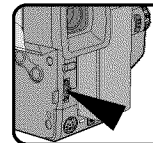

LCD ADJUST
 DIS OFF
 D.ZOOM OFF
 WHITE BAL AUTO
 DISPLAY ON
 LANGUAGE ENGLISH
 WL REMOCON ON
 NEXT: MENU

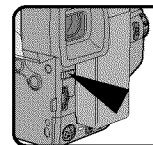

LCD ADJUST
 DIS ON
 D.ZOOM OFF
 WHITE BAL AUTO
 DISPLAY ON
 LANGUAGE ENGLISH
 WL REMOCON ON
 NEXT: MENU

- Notes:**
1. It is recommended you deactivate the handshake compensation function when using a tripod.
 2. The DIS function will not operate in the DSE mode.
 3. The MENU ON/OFF function will not operate in EASY mode.

ENGLISH**Advanced Recording****MF/AF (Manual Focus/Auto Focus)**

- ❖ The MF/AF function works in the CAMERA mode only.
- ❖ In most situations, it is better to use the Automatic Focus feature, as it enables you to concentrate on the creative side of your recording.
- ❖ Manual focusing may be necessary under certain conditions that make automatic focusing inadequate.

Auto Focusing

- ❖ The AF (Auto Focus) mode is set automatically when you switch on the Power switch.
- ❖ If you are inexperienced with camcorders, we recommend that you use the Auto Focus mode.

Manual Focusing

- ❖ In the following situations, you should obtain better results by adjusting the focus manually.
 - a. A picture containing several objects, some close to the camcorder, others further away.
 - b. A person enveloped in fog or surrounded by snow.
 - c. Very shiny or glossy surfaces like a car.
 - d. People or objects moving constantly or quickly like an athlete or crowd.
1. Set the power switch to CAMERA mode. (see page 18)
 2. Press the MF button.
 3. Zoom in the subject to be recorded by pushing the ZOOM tab to the "T" side.

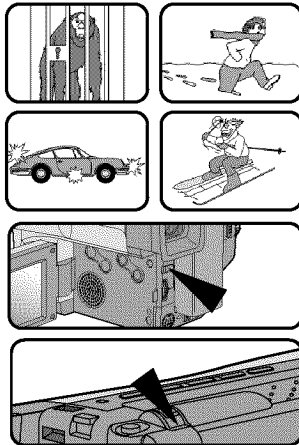

Advanced Recording

4. Turn the UP/DOWN dial up or down until the object is focused.
5. You will obtain a sharp picture after zooming out.
6. To return to AF(Auto Focus), press the MF button again.

Note: The MF function will not operate in EASY mode.

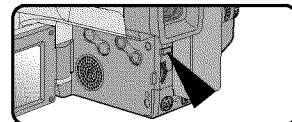
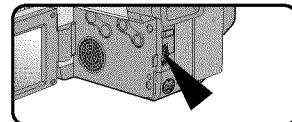

BLC

BLC works in the CAMERA mode.

Back lighting exists when the subject is darker than the background:

- The subject is placed in front of a window.
- The person to be recorded is wearing white or shiny clothes and is placed against a bright background; the person's face is too dark to distinguish their features.
- The subject is outdoors and the background is overcast.
- The light sources are too bright.
- The subject is against a snowy background.

* BLC off

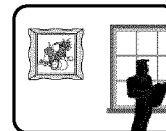

* BLC on

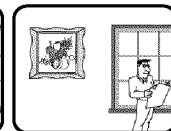

1. Set the power switch to CAMERA mode. (see page 18)
2. Press BLC button.
 - Normal - BLC - Normal
 - BLC enhances only the subject.

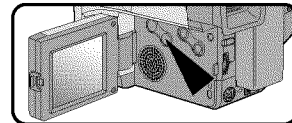

Note: BLC function will not operate in P.AE or EASY mode.

ENGLISH

Advanced Recording

PROGRAM AE (Automatic Exposure)

- ❖ The PROGRAM AE function works in the CAMERA mode only.
- ❖ The PROGRAM AE modes allow you to adjust shutter speeds and aperture to suit different recording conditions. They give you creative control over the depth of the field.
- ❖ There are 6 automatic exposure modes.
- ❖ The flicker appears when photographing from the interior fluorescent lamp lower part.

1. AUTO mode

- Auto balance between the subject and the background.
- To be used in normal conditions.
- The shutter speed automatically varies from 1/60 to 1/250 second, depending on the picture.

2. SPORTS mode ()

- For recording people or objects moving quickly; you should be able to play back the picture in slow motion on an 8 mm VCR or stop on a given image with very little blur.

3. PORTRAIT mode ()

- For focusing on the background of the subject, the background being out of focus.
The PORTRAIT mode is most effective when used outdoors.
- The shutter speed automatically varies from 1/60 to 1/1000 second, depending on the picture.

4. SPOTLIGHT mode ()

- To record correctly when there is only light on the subject and not the rest of the picture.
- The shutter speed is 1/60 second.

5. SAND/SNOW mode ()







- For recording when the people or objects are darker than the background because of reflected light from sand or snow.
- The shutter speed automatically varies from 1/60 to 1/250 second, depending on the picture.

6. HSS (High Speed Shutter) mode ()

- For recording fast-moving subjects such as the players in golf or tennis games.
- You may need to light the recording area.

Advanced Recording

Setting the PROGRAM AE(Automatic Exposure) mode

1. Set the power switch to CAMERA mode. (see page 18)
2. Press the P.AE button, the () symbol will be displayed.
3. Press the P.AE button until the appropriate symbol is displayed.
( →  →  →  → )
 ■ No Display : Auto mode.

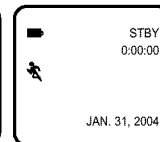
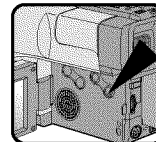

Notes:

- The screen status that is changed by the P.AE button will be recorded on the tape.
- To end the P.AE function, press the P.AE button once or several times, until the P.AE Icon is no longer displayed.
- The P.AE function will not operate in EASY or CUSTOM mode.
- The BLC function will not operate in P.AE mode.

ENGLISH**Advanced Recording*****DSE (Digital Special Effects) in CAMERA mode***

- ❖ The digital effects enable you to give a creative look to your recording by adding various special effects.
- ❖ Select the appropriate digital effect for the type of picture that you wish to record.
- ❖ There are several DSE modes. (SCL901: 8 modes, SCL906/L907: 9 modes)

1. Normal picture.
2. STROBE: This mode works by inserting a cutting effect on the image. There are 50 fields in a normal recorded picture. (SCL906/L907 only)
3. SEPIA: This mode gives the image a SEPIA effect.
4. B&W(Black & White): This mode allows the image to be recorded in black and white.
5. NEG.(Negative): This mode allows images to be recorded by reflecting the color of the image.
6. MIRROR: This mode cuts the image in half, using the mirror effect.
7. ART: Adds a paint-like effect, called solarization, to the image.
8. MOSAIC: This mode gives the image a checkered design.
9. 16:9(WIDE): This mode provides a 16:9(WIDE) television display.
10. CINEMA: This mode covers the upper/lower portion of the screen to give a movie-like effect.

- Notes:**
- DIS function will not operate in DSE mode. (SCL906/L907 only)
 - DSE function will not operate in EASY mode.

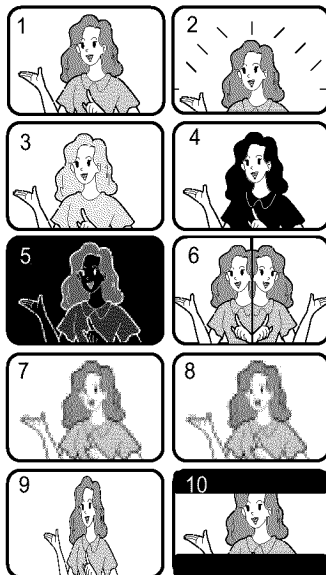

Advanced Recording

Selecting and recording DSE effects

1. Set the power switch to CAMERA mode. (see page 18)
2. Press the DSE button, STROBE or SEPIA will be displayed.
3. Keep pressing the DSE button, until the desired mode is displayed.
4. Press the START/STOP button to start recording.
5. To exit the DSE functions, press the DSE button once or several times until no DSE mode is displayed on the LCD.

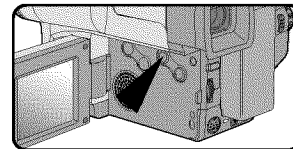

- Notes:**
- It is recommended that you set the DSE mode in STBY mode.
 - DSE functions will not operate in EASY mode.

ENGLISH**Advanced Recording****Setting and Recording the DATE/TIME**

- ❖ Setting and recording the date/time feature works in the CAMERA mode only.
- ❖ You can record the date/time on your tapes, so you will know when it was made. The date and time are recorded whenever they are displayed on the viewfinder or LCD.

Setting a DATE/TIME

- ❖ Setting the DATE/TIME is possible in STANDBY of CAMERA mode only.
1. Make sure that you have installed the LITHIUM BATTERY. (see page 17)
The LITHIUM BATTERY is needed to maintain the clock.
 2. Set the power switch to CAMERA mode. (see page 18)
 3. Press the MENU ON/OFF button, then the MENU list will appear.
 4. Turn the UP/DOWN dial until CLOCK SET is highlighted.
 5. Press ENTER.
 - CLOCK SETTING is possible when the DATE and TIME appear.
 - BLINKING indicates the possible changes for the setting.
The year will be the first to blink.
 6. Turn the UP/DOWN dial to set the desired year.

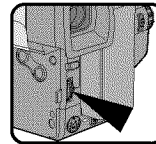
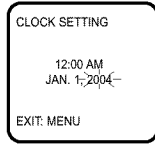
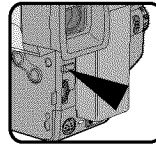
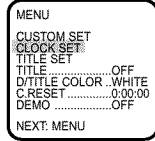
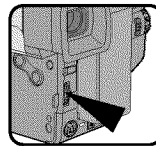
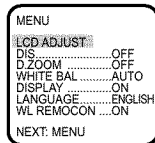
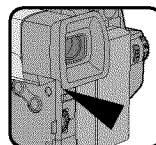

ENGLISH

Advanced Recording

7. Press ENTER.
 - The month to be reset will blink.
8. Turn the UP/DOWN dial to set the desired month.
9. Press ENTER.
 - The day to be reset will blink.
10. You can set the day, hour and minute following the same procedure used for setting the year and month.
11. Press ENTER after setting the minute and the clock setting screen will disappear. The selected date and time will then be displayed.

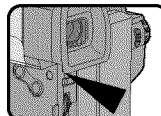

CLOCK SETTING

12:00 AM
-> JAN-1, 2005

EXIT: MENU

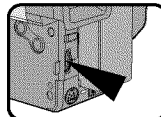

CLOCK SETTING

12:00 AM
-> FEB-1, 2005

EXIT: MENU

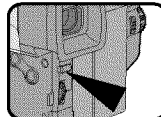

CLOCK SETTING

12:00 AM
FEB. 1, 2005

EXIT: MENU

Recording the DATE/TIME

1. Make sure that you have set the DATE/TIME.
2. Set the power switch to CAMERA mode. (see page 18)
 - Open the LCD Screen and adjust it to see comfortably.
3. Press the DATE/TIME button the required number of times.
 - To record the date only, press the DATE/TIME button once.
 - To record the date and time, press the DATE/TIME button twice.
4. Press the START/STOP button to record the DATE/TIME on your recording.

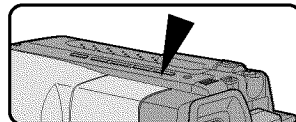

Notes:

- If your date and time settings are not maintained in the camcorder, it means the installed LITHIUM BATTERY is discharged. (see page 17)
- You cannot conceal the recorded date or time during playback.
- The DATE/TIME function will not operate in EASY or CUSTOM mode.

ENGLISH**Advanced Recording****Selecting and Recording a Title**

- ❖ Selecting and recording a TITLE is possible in the CAMERA mode only.
- ❖ The TITLE feature allows you to select a preset title stored in the camcorder's memory.
- ❖ You can also select the language of the titles.

Selecting Title-Language and Setting a Title

- ❖ Selecting a language is possible in STANDBY in CAMERA mode only.
 - ❖ The factory default language is ENGLISH.
You can change the language.
1. Make sure that you have installed the LITHIUM BATTERY or have the adapter attached. (see page 17)
 2. Set the power switch to CAMERA mode. (see page 18)
 - Open the LCD Screen and adjust it to see comfortably.
 3. Press the MENU ON/OFF button.
The MENU list will appear.
 4. Turn the UP/DOWN dial until TITLE SET is highlighted.
 5. Press ENTER.
 - A list of available languages will appear.

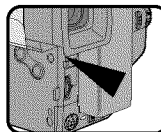

MENU
LCD ADJUST: OFF
DIS OFF
D.ZOOM OFF
WHITE BAL AUTO
DISPLAY ON
LANGUAGE ENGLISH
WL REMOCON ... ON
EXIT: MENU

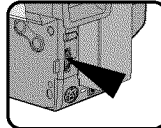

MENU
CUSTOM SET
CLOCK SET
TITLE SET
TITLE OFF
D/TITLE COLOR . WHITE
C/RESET 0:00:00
DEMO OFF
EXIT: MENU

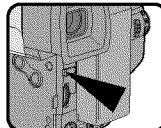

LANGUAGE SELECT
ENGLISH [HAVING FUN]
FRANÇAIS
DEUTSCH
ITALIANO
ESPAÑOL
РУССКИЙ
EXIT: MENU

ENGLISH

Advanced Recording

6. Turn the UP/DOWN dial to select the appropriate language.
 - You may select languages among ENGLISH/FRANÇAIS/DEUTSCH/ITALIANO/ESPAÑOL/РУССКИЙ.
7. Press ENTER.
 - Then, the title list will appear in the language you chose.
8. Turn UP/DOWN dial to whichever TITLE you desire.
9. Press ENTER.
 - The selected title will appear on the screen for 2 ~ 3 seconds and will disappear. At the same time, the camcorder will return to the menu mode.

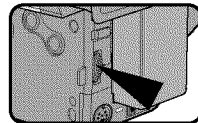

ENGLISH [HAVING FUN]
FRANÇAIS
DEUTSCH
ITALIANO
ESPAÑOL
РУССКИЙ

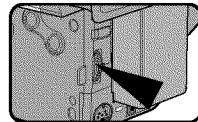

ANNIVERSARY
CONGRATULATIONS:
GRADUATION
HAPPY BIRTHDAY
HAPPY NEW YEAR
HAVING FUN

Recording a Title

Note: ■ Make sure that you have selected a TITLE.

1. Set power switch to CAMERA mode.
 - Open the LCD Screen and adjust it to see comfortably.
2. Press MENU.
3. Turn the UP/DOWN dial until TITLE.....OFF is highlighted.
4. Press ENTER to choose among OFF, AUTO-10S, and CONTINUE.
5. Press START/STOP button to record the title with your picture.
 - If you want to change recording time, select title recording time (OFF, AUTO-10S, CONTINUE) on MENU.

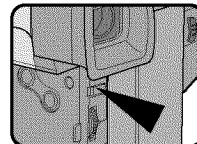

MENU
CUSTOM SET
CLOCK SET
TITLE SET
TITLECONTINUE
D/TITLE COLOR .WHITE
C.RESET0:00:00
DEMOOFF
EXIT: MENU

Notes: ■ The title moves horizontally from the right side to the left side 10 seconds after you turn on the title.
■ MENU ON/OFF function will not operate in EASY or REC mode.

ENGLISH**Advanced Recording****Fade In and Out**

- ❖ The FADE function works in CAMERA mode only.
- ❖ You can give your films a professional look by using special effects such as fading in and out at the beginning or end of a sequence.

To Start Recording

1. Before recording, hold down the FADE button.
The picture and sound gradually disappear (fade out).
2. Press the START/STOP button and at the same time release the FADE button.
Recording starts and the picture and sound gradually appear (fade in).

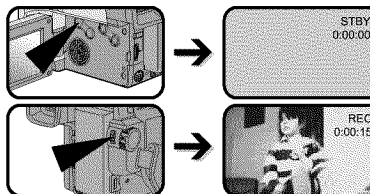
**To Stop Recording (using FADE IN / FADE OUT)**

3. When you wish to stop recording, hold down the FADE button.
The picture and sound gradually disappear (fade out).
4. When the picture has disappeared, press the START/STOP button to stop recording.

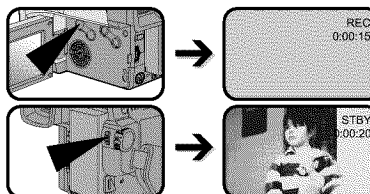

- a. **FADE OUT**
(Approx. 4 seconds)

- b. **FADE IN**
(Approx. 4 seconds)

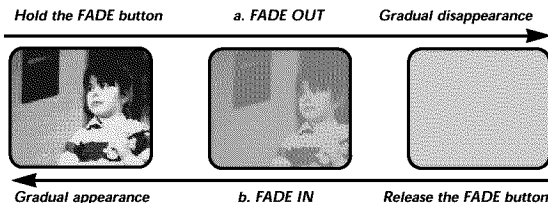

Advanced Recording

Snap Shot (SCL906/L907 only)

- ❖ With the SNAP SHOT feature, your camcorder functions like a regular film camera, allowing you to take single still pictures.
 - The SNAP SHOT function operates in the CAMERA mode.

1. Set the power switch to CAMERA mode.

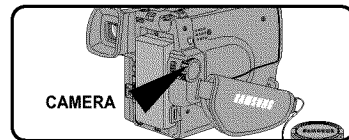

2. Point the Camera at the image you want to record and press the SNAP SHOT button.
 - At this time, be careful not to shake your camcorder because the image will be blurred.

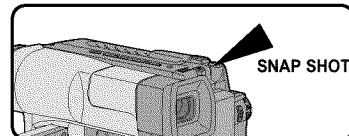

3. After the SNAP SHOT button has been pressed, your camcorder will record the still image for 6 seconds, then automatically return to STANDBY mode.
 - You can check the remaining time for SNAP SHOT recording by looking at the time displayed on the screen.
 - To stop SNAP SHOT recording, press the SNAP SHOT button again.

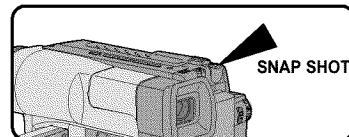

Notes:

- The SNAP SHOT is activated during shooting.
- The still image will be displayed on the display if the SNAP SHOT button is pressed in CAMERA mode.

ENGLISH**Advanced Recording****White Balance**

- ❖ WHITE BALANCE is a recording function that preserves the unique color of the object in any recording condition.
- ❖ You may select the appropriate WHITE BALANCE mode to obtain good color quality of the image.
 - AUTO: This mode is generally used to control the WHITE BALANCE automatically.
 - INDOOR (-☺-): Controls WHITE BALANCE according to the indoor ambience.
 - OUTDOOR (-☼-): Controls WHITE BALANCE according to the outdoor ambience.

Setting a White Balance Mode

1. Set the power switch to CAMERA mode.
2. Press the MENU ON/OFF button, the MENU list will be displayed.
3. Turn the UP/DOWN dial until WHITE BAL.AUTO is highlighted.
4. Press ENTER.
 - You can set it to INDOOR or OUTDOOR by pressing the ENTER button.
5. Press the MENU ON/OFF button to exit the WHITE BALANCE setting.

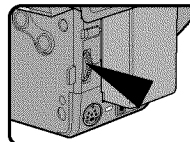

MENU
 LCD ADJUST:
 DISOFF
 D.ZOOMOFF
 WHITE BALAUTO
 DISPLAYON
 LANGUAGEENGLISH
 WL REMOCONON
 EXIT: MENU

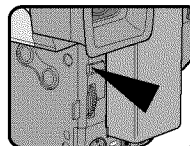

MENU
 LCD ADJUST
 DISOFF
 D.ZOOMOFF
 WHITE BALAUTO
 DISPLAYON
 LANGUAGEENGLISH
 WL REMOCONON
 EXIT: MENU

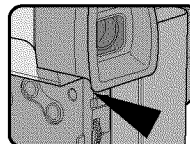

MENU
 LCD ADJUST
 DISOFF
 D.ZOOMOFF
 WHITE BALOUTDOOR-☼-
 DISPLAYON
 LANGUAGEENGLISH
 WL REMOCONON
 EXIT: MENU

Note: The MENU ON/OFF function will not operate in EASY or REC mode.

Advanced Recording

Selecting OSD Language

1. Press the MENU ON/OFF button.
 - The MENU list will appear.
2. Turn the UP/DOWN dial to LANGUAGE and press the ENTER button.
3. Turn the UP/DOWN dial to select the appropriate language.
 - You may select languages among ENGLISH/ESPAÑOL/FRAÑÇAIS.
4. Press the ENTER button.
5. To exit the menu, press the MENU ON/OFF button.
 - The OSD changes with the language which is selected.

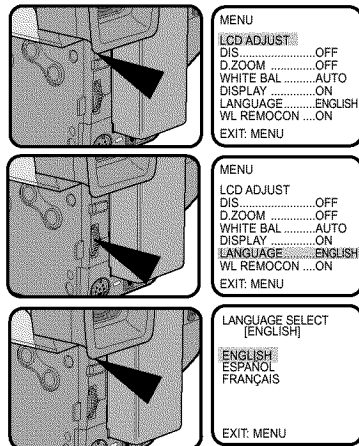

Notes:

- The factory default language is ENGLISH.
- Selecting a language is possible in CAMERA mode or VCR mode.

ENGLISH

Advanced Recording

Demonstration

- ❖ Demonstration automatically shows you the major functions that are included with your camcorder so that you may use them more easily.
- ❖ The DEMO function is only available in CAMERA mode when a tape is not in the camcorder.
- ❖ The Demonstration operates repeatedly until the POWER switch is set to OFF.

1. Set the power switch to CAMERA mode.
2. Press the MENU ON/OFF button, then the MENU list will appear.

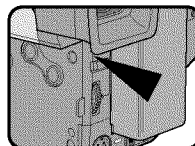

MENU
 LCD ADJUST: OFF
 DIS OFF
 D.ZOOM AUTO
 WHITE BAL ON
 DISPLAY ENGLISH
 WL REMOCON ON
 EXIT: MENU

3. Turn the UP/DOWN dial so that DEMO is highlighted.

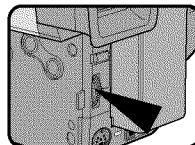

MENU
 CUSTOM SET
 CLOCK SET
 TITLE SET
 TITLE OFF
 D/TITLE COLOR ..WHITE
 C.RESET 0:00:00
 DEMO OFF
 EXIT: MENU

4. Press ENTER to select ON.
 - Demonstration will start.

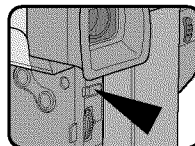

SAMSUNG

 DEMONSTRATION

5. Set the power switch to OFF to end the Demonstration.

Note: The MENU ON/OFF function will not operate in EASY or REC mode.

Advanced Recording

Setting the Date/Title Color

- Set the power switch to CAMERA mode. (see page 18)
- Press the MENU ON/OFF button.
 - The MENU list will appear.
- Turn the UP/DOWN dial to D/TITLE COLOR.....WHITE.
- Press ENTER.
 - A list of available colors will appear.
- Turn the UP/DOWN dial to select the appropriate color.
- Press ENTER.
 - Press the DATE/TIME button to choose whether the date and/or time will be displayed.
- Press the MENU ON/OFF button to end setting.
 - The Title and Date/Time will appear in the Color you chose.

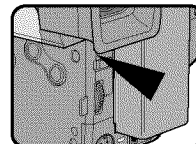

MENU
 LCD ADJUST.....OFF
 D.ZOOMOFF
 WHITE BALAUTO
 DISPLAYON
 LANGUAGE.....ENGLISH
 WL REMOCONON
 NEXT: MENU

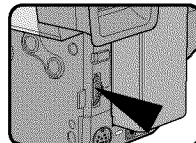

MENU
 CUSTOM SET
 CLOCK SET
 TITLE SET
 TITLEOFF
 D/TITLE COLOR..WHITE
 C.RESET0:00:00
 DEMOOFF
 EXIT: MENU

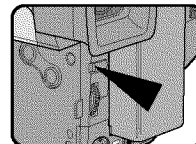

DATE/TITLE COLOR SELECT
 [WHITE]
 WHITE
 YELLOW
 CYAN
 MAGENTA
 RED
 GREEN
 BLUE
 EXIT: MENU

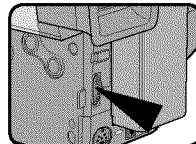

DATE/TITLE COLOR SELECT
 [YELLOW]
 WHITE
 YELLOW
 CYAN
 MAGENTA
 RED
 GREEN
 BLUE
 EXIT: MENU

ENGLISH**Advanced Recording****Lighting Techniques**

- ❖ When you use your camcorder, there are only two possible recording environments.
 - You will be recording outdoors (Normal recording or through an ND(Neutral Density) filter).
 - You will be recording indoors (Video light recommended or required).
- ❖ The single greatest influence on picture quality is the level of brightness, measured in lux.
- ❖ The following table lists a few common situations, the corresponding level of brightness and any associated recommendations.

Situations	Brightness (lux)	Recommendations
<ul style="list-style-type: none"> ◆ Snow-covered mountains or fields. ◆ Sandy beach on a hot summer's day 	100,000 100,000	ND filter recommended.
<ul style="list-style-type: none"> ◆ On a sunny day in the middle of the afternoon. ◆ On a gloomy day, an hour after the sunrise. ◆ Office with fluorescent lighting near to a window. ◆ On a sunny day, an hour before the sunset. ◆ Department store counter. 	35,000 2,000 1,000 1,000 500 to 700	Normal recording.
<ul style="list-style-type: none"> ◆ Room lit by two 30W fluorescent lights. 	300	Video light recommended.
<ul style="list-style-type: none"> ◆ Arcade at night. ◆ Candle light. 	150 to 200 10 to 15	Video light required.

After Recording

1. Eject the tape that you have recorded. (see page 22)
2. If you want to protect accidental erasure of the tape you have recorded, push the red tab on the cassette.
3. Set the POWER switch to OFF.
4. Close the LENS cover.
5. Remove the BATTERY PACK from the camcorder.

Playing back a Tape

- ❖ To view a tape that you have recorded.
- ❖ Playback function works in PLAYER mode only.
- ❖ There are two ways to see a tape;
 - To watch with LCD: recommended for outdoor use.
 - To watch with TV monitor: recommended for indoor use.

To watch with LCD

- ❖ It is practical to view a tape using the LCD Screen in a car or the outdoors. (see page 28)

To watch with TV

- ❖ It is practical to use a TV monitor to view tapes indoors.
- ❖ To play a tape back, the TV must feature a compatible color system. (see page 63)

Connecting to a TV which has an Audio and Video input jack

- ❖ Use the Audio/Video cable supplied with your camcorder.
 - The yellow plug: Video
 - The white plug: Audio(L)-Mono

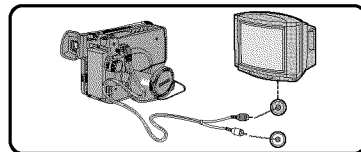

Connecting to a TV which has no Audio and Video input jack

- ❖ You can connect your camcorder to a TV through a VCR.
 - Set the input selector on the VCR to LINE.
 - The yellow plug: Video
 - The white plug: Audio(L)-Mono

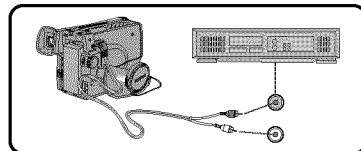

Note: To view the cassette on the television screen, select the channel reserved for your VCR on the television.
(Refer to your VCR or television instruction book)

ENGLISH**Playing back a Tape****Notes:**

- SCL901/L906/L907 feature a monaural audio system. If your TV or VCR features a stereo audio system, connect the audio cable to input "L" of your TV or VCR.
- You can use an S-VIDEO cable to obtain better quality of pictures if you have a S-VIDEO connector on your TV.
- While playing back on a TV screen, close the LCD panel. Otherwise, picture distortion may occur.

Playback

1. Use the TV/VIDEO button to select VIDEO on your TV.
2. Connect power source (battery or AC Power Adapter) to the camcorder. Set the power switch to PLAYER mode.
3. Insert a tape you want to see.
 - Make sure that STOP is displayed.
4. Press the ►|| (PLAY/STILL) button.
 - The picture you recorded appears on the TV after 2 to 3 seconds.
 - Press ■ (STOP) to stop playing.
 - If the tape reaches its end during playback, the tape will rewind automatically.

**Notes:**

- Vibration from the built-in speaker can cause picture distortion.
- It is best to turn the built-in speaker off when your camcorder is connected to the TV.
- The system (Hi8/8mm) is selected automatically, depending on the tape format.
- This camcorder does not support LP recording and playback.

Playing back a Tape

Various Functions in **PLAYER** mode

To view a **STILL** picture (Playback pause)

- Press ►|| (PLAY/STILL) button during playback.
- To resume playback, press ►|| (PLAY/STILL) button again.

Note: Your camcorder will automatically stop if it is left for more than 5 minutes in STILL mode without operation in order to prevent tape and head-drum wear.

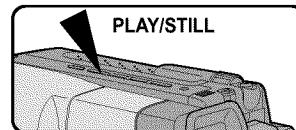

To locate a scene (picture search)

- Press ►► (FF) or ◀◀ (REW) buttons during playback. To resume normal playback, release the buttons.

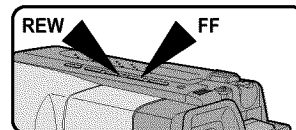

Zero **RETURN** (SCL906/L907 only)

- ❖ The ZERO RETURN function works in **PLAYER STOP** mode.
 - ❖ You can Fast Forward or Rewind to 0:00:00 automatically.
1. Set the power switch to **PLAYER** mode.
 - Make sure that **STOP** is displayed.
 2. Press the ZERO RETURN button.
 - Z.RTN is displayed.
 - FF or REW works automatically.

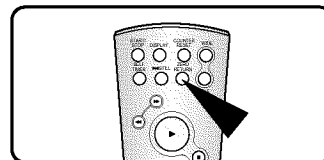

Notes:

- The ZERO RETURN button does not work when the TAPE COUNTER reads 0:00:00.
- Set the COUNTER RESET to "C.RESET 0:00:00" in MENU mode at the start of the cassette or the required sequence. When you wish to find this point on the tape again, press Z.RETURN button when playback is stopped.

ENGLISH**Playing back a Tape****Adjusting the LCD**

- ❖ The LCD control in PLAYER mode is identical to step 3 of the page 26, except the power switch must be set to PLAYER mode.

Setting the Speaker ON/OFF

- ❖ The speaker is turned ON/OFF by opening/closing the LCD.
 - ❖ The speaker ON/OFF setting operates when the LCD is opened. When it is set to OFF, the speaker won't turn on even after opening the LCD.
1. Set the power switch to PLAYER mode.
 2. Press the MENU ON/OFF button, then the MENU list will appear.
 3. Turn the UP/DOWN dial to SPEAKER.
 4. Press ENTER to choose ON or OFF.
 5. Press the MENU ON/OFF button again to end the SPEAKER setting.

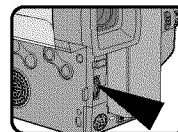

```

MENU
LCD ADJUST
SPEAKER .....ON
DISPLAY .....ON
PAL CONV. ....OFF
WL.REMOCON ...ON
C.RESET .....0:00:00
LANGUAGE.....ENGLISH
EXIT: MENU
  
```

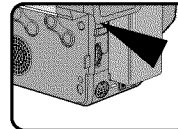

```

MENU
LCD ADJUST
SPEAKER .....OFF
DISPLAY .....ON
PAL CONV. ....OFF
WL.REMOCON ...ON
C.RESET .....0:00:00
LANGUAGE.....ENGLISH
EXIT: MENU
  
```

Volume control

- ❖ Speaker volume can be controlled by turning the UP/DOWN dial during playback.

Note: When the MENU list is on, volume will not be changed.

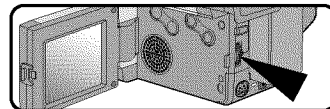
**DSE in PLAYER mode**

- ❖ The procedure for using DSE in PLAYER mode is the same as the procedure for using DSE in CAMERA mode, except that the power switch must be set to PLAYER instead of CAMERA. Please refer to pages 40 and 41.
- Note:** The STROBE, NEG., MIRROR, MOSAIC, CINEMA and 16:9(WIDE) effects will not operate when your camcorder is in PLAYER mode.
- ❖ Pressing the DSE button will scroll through the available settings. Stop at the one you require.

Playing back a Tape

Multi Playback (using a PAL60 System)

- ❖ This Camcorder can convert an NTSC tape recorded in the SP mode to the "PAL60" format, allowing you to view it on a PAL TV which has Vertical sync adjustment circuitry for 60Hz.
 - "PAL60" is a special output signal format with which a PAL TV can be used to view a tape recorded by an NTSC recorder.
1. Set power switch to PLAYER mode.
 2. Insert an NTSC tape you want to see.
 3. Press MENU ON/OFF button, then the MENU list will appear.
 4. Turn the UP/DOWN dial to "PAL CONV.OFF".
 5. Press ENTER, then it will change to "PAL CONV.PAL60".
 - Now you can see the picture by pressing the PLAY button.
 6. Press MENU ON/OFF button to end setting.

- Notes:**
1. This Camcorder can not record using the "PAL60" system.
 2. When an NTSC tape is being played back, the picture on the monitor screen shrinks in the Vertical direction.
 3. If the signal recorded on the tape is in bad condition, the PAL60 playback system may malfunction.
 4. A PAL recorded tape can not be normally played back when "PAL60" is set or displayed.

ENGLISH**USB interface (SCL907 only)*****Transferring a Digital Image through a USB Connection***

- ❖ You can easily transfer a still image from a camera, tape, memory to a PC without additional add-on cards via a USB connection.
- ❖ If you transfer data to a PC, you need to install the software (Driver, Editing software) supplied with the camcorder.

System Requirements

- CPU : Intel® Pentium II™ processor compatible or better
- Operating system : Windows® 98/98SE/ME/2000/XP
- RAM : 64 MB or more
- CD-ROM: 4x CD-ROM drive
- VIDEO : 65,000-color or better video display card
- Available USB port
- Hard Disc : 4GB (8GB recommended)

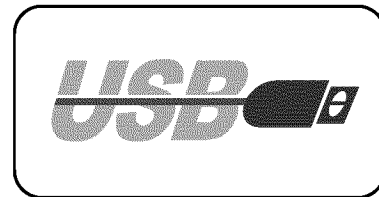
**Notes:**

- Intel® Pentium II™ is a trademark of the Intel Corporation.
- Windows® is a registered trademark of the Microsoft® Corporation.
- All other brands and names are property of their respective owners.

USB interface (SCL907 only)

Installing USB Media 2.0 Program

- ❖ Do not connect the camcorder to PC before installing the program.
- ❖ If another camera or scanner is connected, please disconnect it in advance.
- ❖ This explanation is based on Windows® 98SE OS.

How to install the program

1. The install program automatically operates when the CD is inserted into CD-ROM.



Note:

If the program installed does not operate, double click Install.exe in CD-ROM Drive.

2. Click  to install the program.
3. Follow the installation instructions.

ENGLISH**USB interface (SCL907 only)**

4. The window below displays the folder to install the program.
 - The program is installed in the following folder.
C:\Programfiles\Samsung\USB Media 2.0
 - Click  to change the folder.
5. Connect the camcorder to PC.
6. PC finds the new hardware and installs the driver automatically.
7. If the driver is installed, the installation is completed.
8. Execute USB Media 2.0 player on the Windows wall paper.

Note:

- USB Media 2.0 User's Manual is included on the accompanying CD in Adobe's Portable Document Format (PDF). The user's manual can be viewed using Acrobat Reader software, which is also included on the CD. (The Acrobat Reader is a freeware product of Adobe Systems, Inc.)

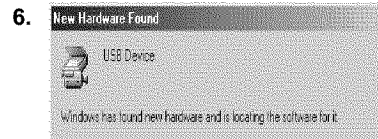
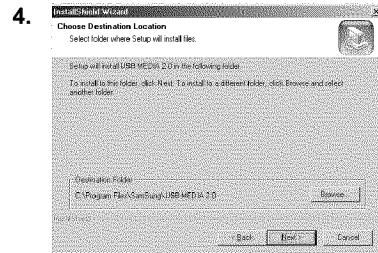

USB interface (SCL907 only)

Connecting to a PC

1. Connect a USB cable to the USB port on the PC.
2. Connect the other end of the USB cable into the proper terminal on the camcorder. (USB jack)
3. Connect the audio cable to the Line input jack of the PC.
If the PC has no Line input jack, connect the audio cable to the MIC input jack.
This connection, however, may produce noise depending on the PC.

Notes:

- If you disconnect the USB cable from the PC or the camcorder while transferring, the data transmission will stop and the data may be damaged.
- If you connect the USB cable to a PC via a USB HUB or simultaneously connect the USB cable along with other USB devices, the camcorder may not work properly.
 - If this occurs, remove the other USB devices from the PC and reconnect the camcorder.

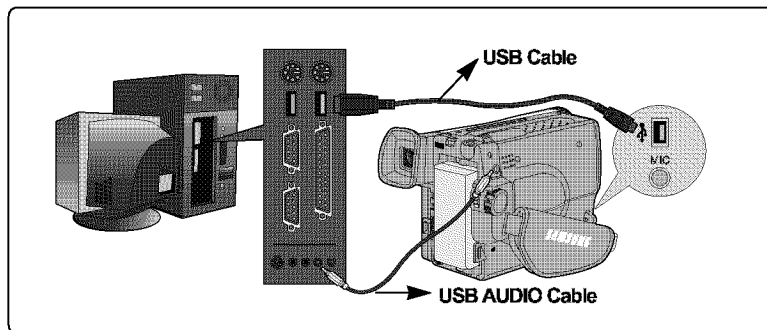

ENGLISH**Maintenance****Cleaning and Taking care of the Camcorder****Cleaning the Viewfinder**◆ **Releasing the Eyecap**

1. Pull the VIEWFINDER up and then turn the screw counter-clockwise.
2. Pull the EYECAP out.
3. Clean the EYECAP and the VIEWFINDER screen with a soft cloth and cotton swab or a blower.

◆ **Reattaching the Eyecap**

4. Put the EYECAP on the VIEWFINDER.
5. Put the screw back on.

Cleaning the LCD Panel

Open the LCD Screen and wipe it gently with a soft cloth. Be careful not to damage the panel.

Cleaning the Video Heads

- ❖ To ensure normal recording and clear pictures, clean the video heads.
- ❖ When the playback pictures are noisy or hardly visible, the video heads may be dirty.

- a. Normal Picture
- b,c. Noisy Picture

If this happens, clean the video heads with a dry type cassette cleaner.

1. Set the power switch to PLAYER mode.
2. Insert the cleaning tape.
3. Press the **▶||** (PLAY/STILL) button.
4. Press the **■** (STOP) button after about 30 seconds. Check the quality of the picture using a video cassette. If it is still bad, repeat the operation. If the problem continues, contact your local authorized service center.

Storing the Camcorder

1. You must detach the BATTERY PACK from the camcorder when storing.
2. Keep the camcorder in a ventilated, dry and warm place.
3. Do not keep the camcorder in a place where the temperature often changes, such as in a car.
4. Keep the camcorder in a stable place.

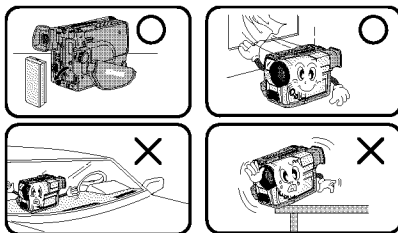
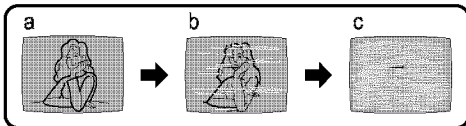
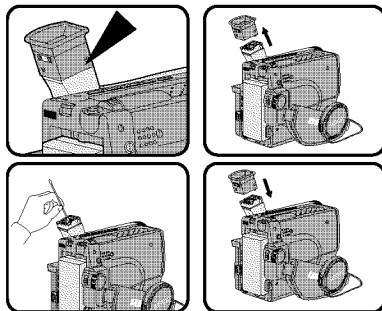

Using Your Camcorder Abroad

Using Your Camcorder Abroad

- ❖ Each country or area has its own electric and TV color system.
- ❖ Before using your camcorder abroad, check the following:

Power sources

- You can use your camcorder in any country or area that uses 100V to 240V, 50/60 Hz.
- Use a commercially available AC plug adapter, if necessary, depending on the power used.

Color system

- You can view your recording on the LCD or viewfinder.
However, to view a recording on a television or to make a copy to a video cassette recorder, the television or VCR must be NTSC: SCL901/L906/L907 - compatible and have the appropriate audio/video jacks.

❖ PAL-compatible area

Australia, Austria, Belgium, Bulgaria, China, CIS, Czech Republic, Denmark, Egypt, Finland, France, Germany, Greece, Great Britain, Holland, Hong Kong, Hungary, India, Iran, Iraq, Kuwait, Libya, Malaysia, Mauritius, Rumania, Saudi Arabia, Singapore, Slovak Republic, Spain, Sweden, Switzerland, Syria, Thailand, Tunisia, etc.

❖ NTSC-compatible area



Bahamas, Canada, Central America, Japan, Mexico, Philippines, Korea, Taiwan, United States, etc.

Note: You can make recordings with your camcorder anywhere in the world.

ENGLISH**Troubleshooting****Troubleshooting**

- ❖ Before contacting a service center, perform the following simple checks. They might save you the time and expense of an unnecessary call.

Self Diagnosis Display

Display	Blinking	Inform that...	Action
	slow	the battery pack is almost discharged	Change it to a charged one.
	fast	the battery pack is fully discharged.	Change it to a charged battery.
TAPE END!	slow	the tape has almost reached its end.	Prepare a new one.
TAPE END!	no	the tape reached its end	Change to a new one.
TAPE!	slow	there is no tape in the camcorder.	Insert a tape.
PROTECTION!	slow	the tape is protected from recording.	If you want to record, release the protection tab.
D.EMG C.EMG R.EMG L.EMG	slow	the camcorder has some mechanical fault.	1. Eject the tape. 2. Set to OFF 3. Detach the battery. 4. Reattach the battery. * Please contact your local service center if the problem continues.
	slow	moisture condensation has formed in the camcorder.	see page 67.

Troubleshooting

Checking

- ❖ If you run into any problem using the camcorder, use the following table to troubleshoot the problem.
- ❖ If these instructions do not allow you to solve the problem, take a note of:
 - The model and serial number marked on the bottom of the camcorder.
 - Your warranty, if applicable.
- ❖ Then contact your nearest Samsung authorized service center.

Symptom	Explanation/Solution
You cannot switch the camcorder on.	<ul style="list-style-type: none"> ◆ Check the battery pack (see page 19) or the AC power adapter. (see page 18)
Start/Stop does not operate while shooting.	<ul style="list-style-type: none"> ◆ Check the POWER, set it to CAMERA. ◆ You have reached the end of the cassette. ◆ Check the record protection tab on the cassette. (see page 22)
The camcorder goes off automatically.	<ul style="list-style-type: none"> ◆ You have left the camcorder set to STANDBY for more than 5 minutes without using it. (see page 24) ◆ The battery pack is fully used up. (see page 21)
The battery pack is quickly exhausted.	<ul style="list-style-type: none"> ◆ The atmospheric temperature is too low. (see page 21) ◆ The battery pack has not been charged fully. (see page 19) ◆ The battery pack is completely dead, and cannot be recharged. Use another battery pack.
You cannot eject the cassette from the compartment.	<ul style="list-style-type: none"> ◆ The battery pack is fully used up. ◆ A mechanical fault might have occurred. (see page 64)
The DATE/TIME indicator flashes more than 2 times when you set the camcorder to CAMERA.	<ul style="list-style-type: none"> ◆ The lithium battery is not installed or is fully used up. (see page 17)
The playback picture is poor.	<ul style="list-style-type: none"> ◆ The video heads might be dirty. (see page 62)
You cannot operate any functions on the camcorder.	<ul style="list-style-type: none"> ◆ A mechanical fault might have occurred. (see page 64)

ENGLISH**Troubleshooting**

Symptom	Explanation/Solution
A vertical stripe appears when you record a bright subject against a dark background (candle flame, for example).	◆ The contrast between the subject and the background is too great for the camcorder to operate normally. Make the background bright to reduce the contrast or use the BLC function while you are recording. (see page 37)
The image quality on the LCD is poor.	◆ The use of VIEWFINDER is recommended when recording under sunlight. (see page 7) ◆ Adjust the LCD. (see page 26)
The image in the viewfinder is blurred.	◆ The viewfinder lens has not been adjusted. Turn the viewfinder focus ring until the screen comes into sharp focus. (see page 27)
The tape does not move when you press the Play, Fast Forward or Rewind buttons.	◆ Set the POWER switch to PLAYER. ◆ You have reached the beginning or end of the cassette.
The picture does not appear in the viewfinder.	◆ The LCD Screen is opened.
There is no sound from the SPEAKER when playing back the tape.	◆ Make sure the SPEAKER is ON. (see page 56)
The Date/Time or Title disappeared even though you had it set.	◆ The lithium battery is not installed or is fully used up. (see page 17)

Troubleshooting

Moisture Condensation

- ❖ If the camcorder is brought directly from a cold place to a warm place, moisture may condense inside the camcorder, on the surface of the tape, or on the lens. In this condition, the tape may stick to the head drum and be damaged or the unit may not operate correctly.

To prevent possible damage under these circumstances, the camcorder has a built-in moisture sensor.

- ❖ If there is moisture inside the camcorder, "DEW()" is displayed. If this happens, none of the functions except cassette ejection will work. Open the cassette compartment and remove the battery for at least two hours in a warm dry room.
- ❖ Please follow this procedure when the DEW protection feature is unexpectedly activated and you want to override it: (Please make sure that the condensation has disappeared completely.)

1. Take the battery pack out.
2. Take the lithium battery out.
3. Put the lithium battery back.
4. Put the battery pack back.

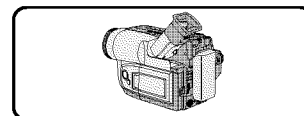
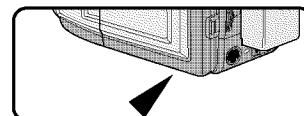
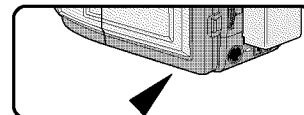
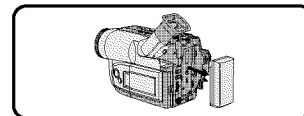
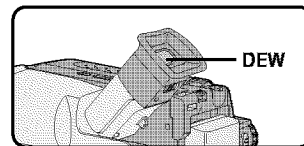

ENGLISH**Specifications**

❖ The design and technical specifications may be changed without notice.

System	SCL901/L906/L907
Recording system	Video: 2 rotary heads Helical scanning FM Audio: FM monaural system
Video signal	NTSC color, EIA standard
Usable cassette	Hi8 or 8mm
Tape speed	SP: 14.345 mm/sec
Speed mode	Record: SP only Playback: SP only
Recording time	P6-120: 120 min.
FF or REW time	P6-120: approx. 6.5 min.
Image device	CCD (Charge Coupled Device)
Optical zoom ratio	22x
Focal length: f	3.6~79.2 mm
F	1.6
Filter diameter	46 mm
Focus system	Inner
Macro	Auto wide macro
Min. Illumination	0.3 lux (visible)
LCD Screen	
Size/Picture cell	2.5 inch/112k
Method	TFT
Connectors	
Video out	Mini jack, 1 Vp-p, 75 ohms, Unbalanced
Audio out	Mini jack, 7.7 dBs, imp.: less than 820 ohms
External mic	Monaural ø3.5 (SCL906/L907)
General	
Power requirement	DC 8.4 V (1.5 A)
Power consumption	4.8 W
*Recording, LCD ON	
Built-in mic	Condenser mic, omni-directional
Built-in speaker	Dynamic, 0.5 W standard
Operating temperature	0°C to 40°C (32°F to 104°F)
Dimension (WxHxD)	101x104x169 mm (3.98x4.09x6.65 inches)
Weight	790 g (1.47lbs)

Index

- A -		- E -	
ABROAD	63	EASY	33
AC POWER ADAPTER	18	EJECT	22
ADJUSTING	26	ENTER	26
AF	36	EXTERNAL MIC	68
AUDIO	53		
AUTO FOCUSING	36	- F -	
AUTO MODE	38	FADE IN	46
AUTO POWER OFF	24	FADE OUT	46
		FAR	36
- B -		FF (FAST FORWARD)	55
BATTERY	19	FILTER DIAMETER	68
BATTERY LEVEL	21	FOCAL LENGTH	68
BATTERY PACK	19		
BLC	37	- H -	
BRIGHTNESS	26	HAND STRAP	16
		Hi8	54
- C -			
CAMERA	18	- L -	
CASSETTE	22	LCD	26
CASSETTE HOLDER	11	LENS	9
CLEANING	62	LITHIUM BATTERY	17
COLOR	26	LOCK	18
CONTENTS	2		
COUNTER	55	- M -	
CUSTOM	34	MIRROR	40
		MOISTURE	64
- D -		MOSAIC	40
DATE	42	MULTY PLAYBACK	57
DATE/TIME	42		
DC CABLE	18	- N -	
DEMO	50	ND FILTER	52
DEW	67	NEAR	36
DIGITAL ZOOM	31	NEG	40
DIMENSIONS	68	NTSC	63
DIS	35		
DISPLAY	12		
DSE	40		

ENGLISH**Index**

- O -	
OPERATION MODE	13
OSD	12
- P -	
PLAY	54
PLAYER	54
PORTRAIT MODE	38
POWER CONSUMPTION	68
POWER REQUIREMENT	68
POWER SWITCH	18
PROGRAM AE	38
- R -	
RECHARGING	19
REC SEARCH	24
REMOTE CONTROL	15
REW (REWIND)	55
- S -	
SAFETY INSTRUCTIONS	4
SAND/SNOW MODE	38
SELF-30S	15
SELF-END	15
SELF DIAGNOSIS	64
SELF RECORD	15
SELF TIMER	15
SEPIA	40
SHOULDER STRAP	17
SNAP SHOT	47
SPEAKER	56
SPECIFICATIONS	68
SPORTS MODE	38
SPOTLIGHT MODE	38
- T -	
STANDBY	18
START/STOP	23
STILL	55
STOP	54
STROBE	40
SYSTEM	68
S-VIDEO	54
- V -	
TAPE COUNTER	13
TAPE EJECT	22
TAPE END	64
TIME	42
TITLE	44
TV MONITOR	53
- V -	
VIDEO	53
VIDEO HEAD	62
VOLUME	56
- W -	
WAIT-10S	15
WEIGHT	68
WHITE BALANCE	48
- Z -	
ZERO RETURN	55
ZOOM	30

Warranty (SEA Users Only)

SAMSUNG LIMITED WARRANTY

SAMSUNG Electronics America Inc. (SEA), warrants that this product is free from defective material and workmanship.

SEA further warrants that if product fails to operate properly within the specified warranty period and the failure is due to improper workmanship or defective material, SEA will repair or replace the product at it's option.

All warranty repairs must be performed by a SEA authorized service center. The name and address of the location nearest you can be obtained by calling toll free: 1-800 SAMSUNG (1-800-726-7864).

Labor

90 days carry-in

Parts

1 year

On carry-in models, transportation to and from the service center is the customer's responsibility.

The original dated sales receipt must be retained by the customer and is the only acceptable proof of purchase. It must be presented to the authorized service center.

EXCLUSIONS (WHAT IS NOT COVERED)

This warranty does not cover damage due to accident, fire, flood and/or other acts of God; misuse, incorrect line voltage, improper installation, improper or unauthorized repairs, commercial use, or damage that occurs in shipping.

Exterior and interior finish, lamps, and glass are not covered under this warranty.

Customer adjustments which are explained in the instruction manual are not covered under the terms of this warranty. This warranty will automatically be voided for any unit found with a missing or altered serial number. This warranty is valid only on products purchased in the United States and Puerto Rico.

Some States do not allow the exclusions or limitations of incidental or consequential damages, or allow limitations on how long an implied warranty lasts, so the above limitations or exclusions may not apply to you. This warranty gives you specific legal rights, and you may also have other rights which vary from State to State.

ENGLISH

THIS CAMCORDER IS MANUFACTURED BY:



**SERVICE DIVISION
400 Valley Road, Suite 201, Mt. Arlington N.J. 07856
Tel: 1-800-SAMSUNG
(1-800-726-7864)**

***Samsung Electronics' Internet Home Page**
<http://www.samsungusa.com>

AD68-00732M