

PRO-FORM 545s

HeartRateControl

Model No. 831.294251

Serial No. _____

Write the serial number in the space above for future reference.

Serial Number Decal

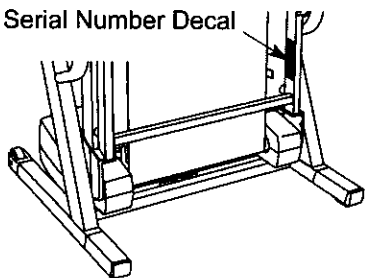

TREADMILL EXERCISER

User's Manual

- Assembly
- Operation
- Maintenance
- Part List and Drawing

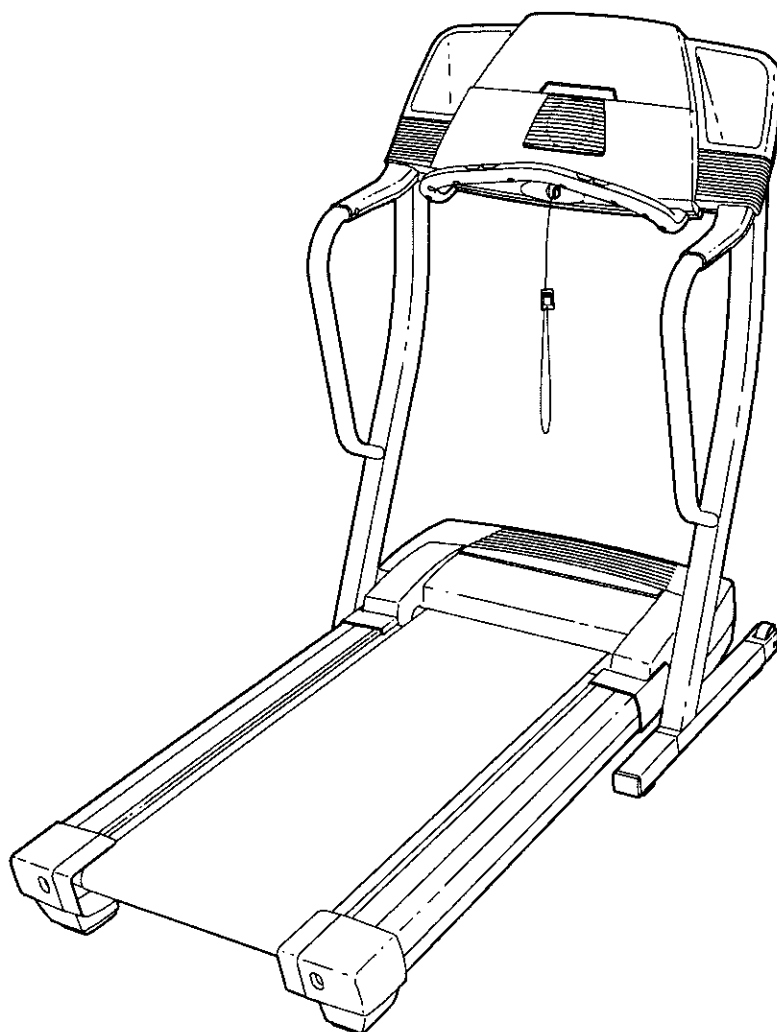

CAUTION

Read all precautions and instructions in this manual before using this equipment. Save this manual for future reference.

Sears, Roebuck and Co., Hoffman Estates, IL 60179

PRO-FORM[®] 545s

HeartRateControl

TABLE OF CONTENTS

IMPORTANT PRECAUTIONS	3
BEFORE YOU BEGIN	5
ASSEMBLY	6
TREADMILL OPERATION	10
HOW TO FOLD AND MOVE THE TREADMILL	24
TROUBLESHOOTING	26
EXERCISE GUIDELINES	28
PART LIST	30
HOW TO ORDER REPLACEMENT PARTS	Back Cover
FULL 90 DAY WARRANTY	Back Cover

Note: An EXPLODED DRAWING is attached in the center of this manual.

IMPORTANT PRECAUTIONS

⚠ WARNING: To reduce the risk of burns, fire, electric shock, or injury to persons, read the following important precautions and information before operating the treadmill.

1. It is the responsibility of the owner to ensure that all users of this treadmill are adequately informed of all warnings and precautions.
2. Use the treadmill only as described in this manual.
3. Place the treadmill on a level surface, with at least eight feet of clearance behind it and two feet on each side. Do not place the treadmill on any surface that blocks air openings. To protect the floor or carpet from damage, place a mat under the treadmill.
4. Keep the treadmill indoors, away from moisture and dust. Do not put the treadmill in a garage or covered patio, or near water.
5. Do not operate the treadmill where aerosol products are used or oxygen is administered.
6. Keep children under the age of 12 and pets away from the treadmill at all times.
7. The treadmill should not be used by persons weighing more than 250 pounds. Never allow more than one person on the treadmill at a time.
8. Wear appropriate exercise clothes when using the treadmill. Do not wear loose clothes that could become caught in the treadmill. Athletic support clothes are recommended for both men and women. *Always wear athletic shoes. Never use the treadmill with bare feet, wearing only stockings, or in sandals.*
9. When connecting the power cord (see page 10), plug the power cord into a surge suppressor (not included) and plug the surge suppressor into a grounded circuit capable of carrying 15 or more amps. No other appliance should be on the same circuit. Do not use an extension cord.
10. Use only a single-outlet surge suppressor that meets all of the specifications described on page 10. To purchase a surge suppressor, see your local Sears or call 1-800-366-7278 and order part number 146148.
11. Failure to use a properly functioning surge suppressor could result in damage to the control system of the treadmill. If the control system is damaged, the walking belt may change speed or stop unexpectedly, which may result in a fall and serious injury.
12. Keep the power cord and the surge suppressor away from heated surfaces.
13. Never move the walking belt while the power is turned off. Do not operate the treadmill if the power cord or plug is damaged, or if the treadmill is not working properly. (See **BEFORE YOU BEGIN** on page 5 if the treadmill is not working properly.)
14. Never start the treadmill while you are standing on the walking belt. Always hold the handrails while using the treadmill.
15. The treadmill is capable of high speeds. Adjust the speed in small increments to avoid sudden jumps in speed.
16. The pulse sensor is not a medical device. Various factors, including the user's movement, may affect the accuracy of heart rate readings. The pulse sensor is intended only as an exercise aid in determining heart rate trends in general.
17. Never leave the treadmill unattended while it is running. Always remove the key, unplug the power cord, and move the reset/off circuit breaker to the off position when the treadmill is not in use. (See the drawing on page 5 for the location of the circuit breaker.)
18. Do not attempt to raise, lower, or move the treadmill until it is properly assembled. (See **ASSEMBLY** on page 6, and **HOW TO FOLD AND MOVE THE TREADMILL** on page 24.) You must be able to safely lift 45 pounds (20 kg) to raise, lower, or move the treadmill.
19. When folding or moving the treadmill, make sure that the storage latch is fully closed.

20. When using iFIT.com CDs and videos, an electronic "chirping" sound will alert you when the speed and/or incline of the treadmill is about to change. Always listen for the "chirp" and be prepared for speed and/or incline changes. In some instances, the speed and/or incline may change before the personal trainer describes the change.

21. When using iFIT.com CDs and videos, you can manually override the speed and incline settings at any time by pressing the speed and incline buttons. However, when the next "chirp" is heard, the speed and/or incline will change to the next settings of the CD or video program.

22. Always remove iFIT.com CDs and videos from your CD player or VCR when you are not using them.

23. Inspect and properly tighten all parts of the treadmill every three months.

24. Never drop or insert any object into any opening.

25. **DANGER:** Always unplug the power cord immediately after use, before cleaning the treadmill, and before performing the maintenance and adjustment procedures described in this manual. Never remove the motor hood unless instructed to do so by an authorized service representative. Servicing other than the procedures in this manual should be performed by an authorized service representative only.

26. The treadmill is intended for in-home use only. Do not use the treadmill in any commercial, rental, or institutional setting.

WARNING: Before beginning this or any exercise program, consult your physician. This is especially important for persons over the age of 35 or persons with pre-existing health problems. Read all instructions before using. Sears assumes no responsibility for personal injury or property damage sustained by or through the use of this product.

SAVE THESE INSTRUCTIONS

The decals shown have been placed on your treadmill. If a decal is missing, or if it is not legible, please call toll-free 1-800-999-3756 and order a free replacement decal. Apply the decal in the location shown. Note: The decals are not shown at actual size.

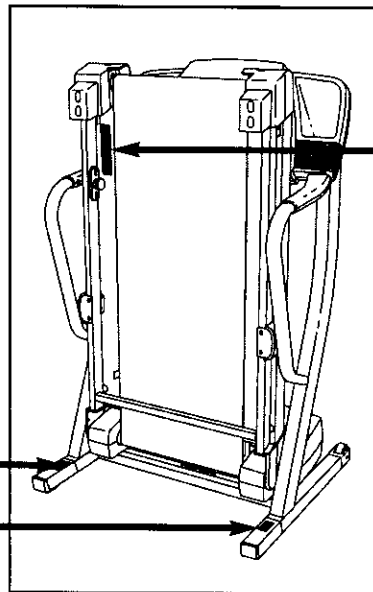

WARNING

Protect yourself and others from risk of serious injury. Read the user's manual and :

-  •Stand only on the side rails when starting or stopping treadmill.
- Change speed in small increments.
- Hold handrails to prevent falling, and always wear the safety clip while operating treadmill.
- Stop if you feel faint, dizzy, or short of breath.
- Fully engage storage latch before treadmill is moved or stored.
- Reduce incline to its lowest level before folding treadmill into storage position.

-  •Never allow children on or around treadmill.
- Remove key when not in use.

-  •Keep clothing, fingers, and hair away from moving belt.
- Never try to adjust or fix the belt while it is moving.
- Always wear athletic shoes while operating treadmill.

BEFORE YOU BEGIN

Thank you for selecting the revolutionary PROFORM® 545s treadmill. The PROFORM 545s treadmill combines advanced technology with innovative design to help you get the most from your exercise program in the convenience and privacy of your home. And when you're not exercising, the unique PROFORM 545s treadmill can be folded up, requiring less than half the floor space of other treadmills.

For your benefit, read this manual carefully before

using the treadmill. If you have questions after reading this manual, call 1-800-4-MY-HOME® (1-800-469-4663). To help us assist you, please note the product model number and serial number before calling. The model number of the treadmill is 831.294251. The serial number can be found on a decal attached to the treadmill (see the front cover of this manual for the location).

Before reading further, please review the drawing below and familiarize yourself with the labeled parts.

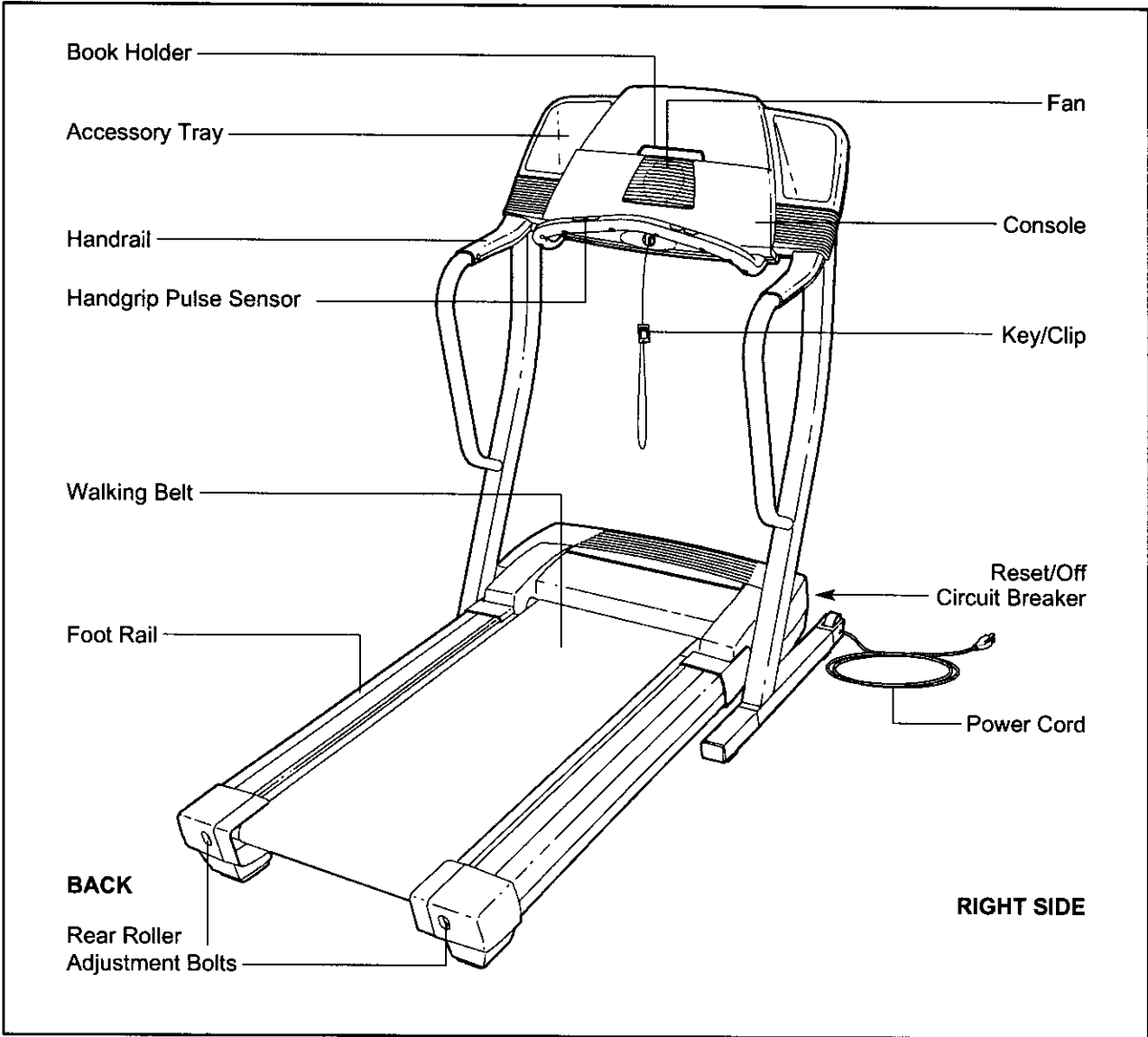

ASSEMBLY

Assembly requires two persons. Set the treadmill in a cleared area and remove all packing materials. Do not dispose of the packing materials until assembly is completed. Note: The underside of the treadmill walking belt is coated with high-performance lubricant. During shipping, a small amount of lubricant may be transferred to the top of the walking belt or the shipping carton. This is a normal condition and does not affect treadmill performance. If there is lubricant on top of the walking belt, simply wipe off the lubricant with a soft cloth and a mild, non-abrasive cleaner.

Assembly requires the included allen wrenches  and your own phillips screwdriver , and wire cutters .

For help identifying assembly hardware, see the drawings below. Note: The assembly hardware and other small parts are packaged in separate part bags. If a part is not found in the part bags, check to see if the part has been preattached. If a part is missing, call toll-free 1-800-999-3756.

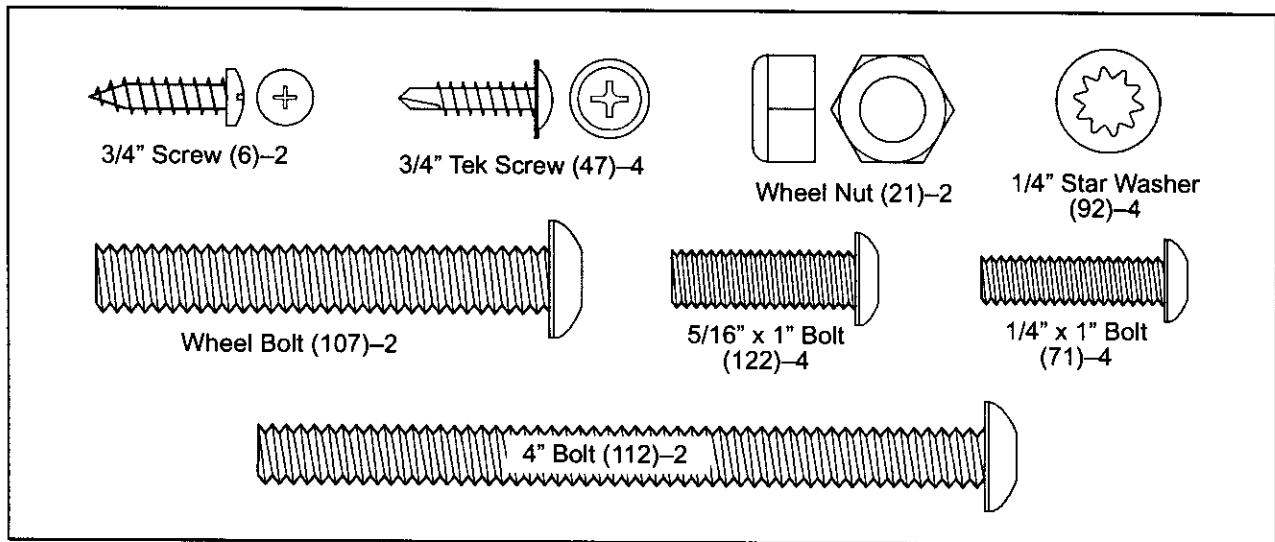

1. With the help of a second person, carefully raise the Uprights (109) to the position shown.

Insert one of the Extension Legs (128) into the treadmill as shown. Make sure that the Extension Leg is turned so the Base Pad (100) is beneath it. Note: It may be helpful to tip the Uprights (109) forward as you insert the Extension Leg.

Insert the other Extension Leg (not shown) in the same way.

Attach a Wheel (108) to each Wheel Housing (106) (only one is shown) with a Wheel Bolt (107) and a Wheel Nut (21). **Make sure that the Wheel Bolts are inserted from the sides shown. Do not overtighten the Wheel Bolts.**

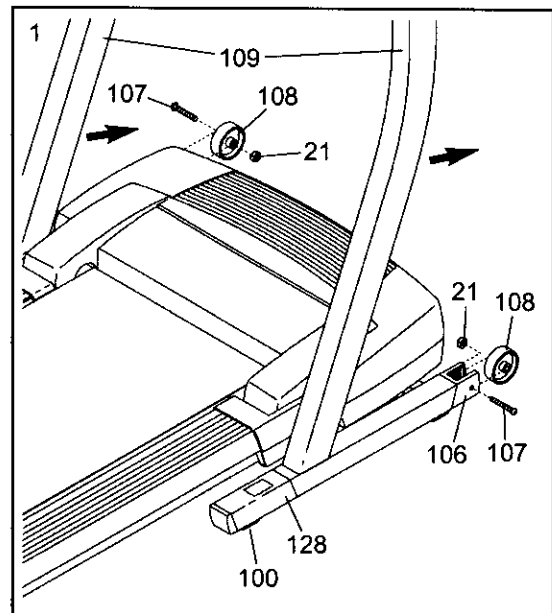

2. Remove the plastic ties and the wood brace from the Uprights (109).

Identify the left handrail, which has a hole in the indicated location, and the right handrail. Hold the right handrail near the right Upright (109), and insert the Wire Harness (83) into the large hole in the right handrail and out of the upper end as shown.

Next, hold the right handrail against the right Upright (109), and hand tighten a 4" Bolt (112) into the right Upright and the lower end of the right handrail. Tighten two 5/16" x 1" Bolts (122) into the upper end of the right handrail and the right Upright. **Be careful not to drop the Bolts into the handrail. Firmly tighten all three Bolts.**

Attach the left handrail as described above. Note: There is not a wire harness in the left Upright (109).

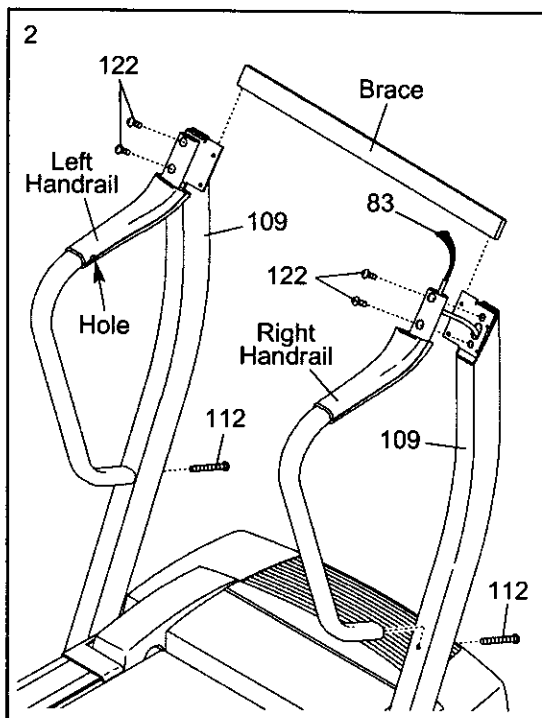

3. With the help of another person, hold the console assembly near the right Upright (109) and the left Upright (not shown).

Connect the Wire Harness (83) to the wire harness in the console assembly. **Make sure to connect the connectors properly (see the inset drawing); the connectors should slide together easily and snap into place.** If the connectors do not slide together easily and snap into place, turn one connector and try to connect them again. **IF THE CONNECTORS ARE NOT CONNECTED PROPERLY, THE CONSOLE MAY BE DAMAGED WHEN THE POWER IS TURNED ON.** Insert the excess wire harnesses back into the right handrail.

Set the console assembly on the right Upright (109) and the Left Upright (not shown). Thread two 1/4" x 1" Bolts (71) with 1/4" Star Washers (92) into each side of the console assembly. **After you have started all four Bolts, tighten them.**

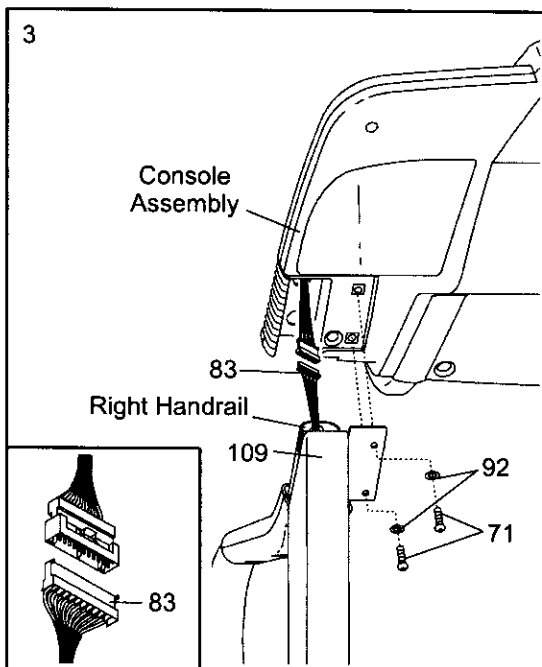

4. With the help of a second person, carefully tip the Uprights (109) down to the position shown. **Make sure that the Extension Legs (128) remain in the Uprights.**

Attach each Extension Leg (128) with two 3/4" Tek Screws (47) and a Round Base Pad (67) as shown. Note: Attach the lower Tek Screw (without the Round Base Pad) first.

With the help of a second person, carefully raise the Uprights (109) so the Base Pads (100) are resting on the floor.

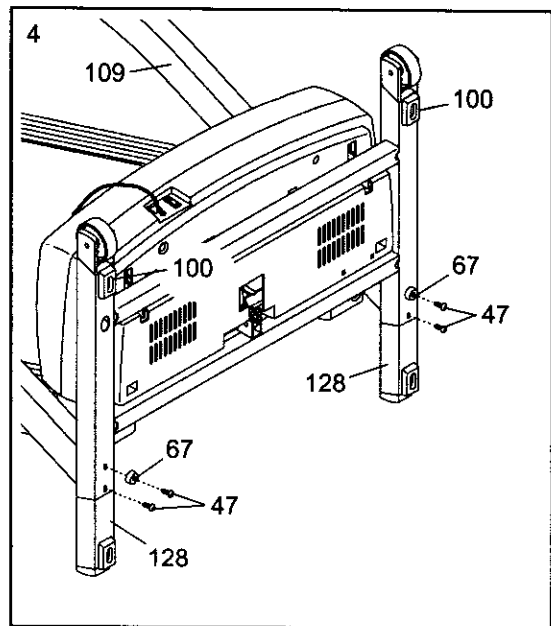

5. Remove the knob from the pin. Make sure that the collar and the spring are on the pin as shown. Insert the pin into the Latch Housing (75) and tighten the knob back onto the pin.

Raise the Frame (54) to the vertical position. While another person holds the Frame, hold the Latch Housing (75) against the inside of the Frame. Thread two 3/4" Screws (6) several turns into the Latch Housing and the Frame.

Align the pin with the hole in the Left Handgrip (76) by sliding the Latch Housing (75) up or down. **Make sure that the pin can be inserted fully into the hole.** Hold the Latch Housing in place and tighten the two 3/4" Screws (6). **Be careful not to overtighten the Screws.**

Pull the knob to the right and carefully lower the Frame (54) to the floor. Press the Latch Cover (12) into the left side of the Frame. See the inset drawing. Make sure that the notch in the Latch Cover is positioned over the Foot Rail (2) as shown.

Note: Over a period of use, the Latch Housing (75) may need to be adjusted again to align the pin with the hole in the Left Handgrip (76).

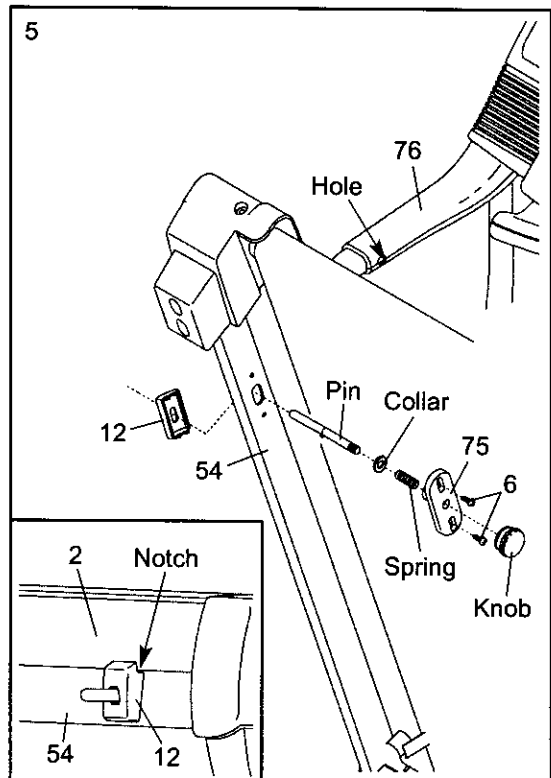

6. **Make sure that all parts are properly tightened before you use the treadmill.** Note: Extra hardware may be included. Keep the included allen wrenches in a secure place. The large allen wrench is used to adjust the walking belt (see page 27). To protect the floor or carpet, place a mat under the treadmill.

If you purchase the optional chest pulse sensor (see page 23), follow the steps below to install the receiver and the short jumper wire included with the chest pulse sensor.

1. **Make sure that the power cord is unplugged.** Remove the indicated 3/4" Screw (6) and the Access Door (94) from the back of the Console Back (95).
2. Connect the wire on the receiver (A) to the indicated wire extending from the Console Back (95). Remove the paper from the adhesive pad on the back of the receiver. **Hold the receiver so the small cylinder is near the lower edge of the receiver and is facing the Console Back as shown.** Firmly press the receiver onto the indicated corner of the Access Door (94). Note: If there are two screws included with the chest pulse sensor and two plastic posts on the inside of the Access Door, attach the receiver to the plastic posts on the Access Door with the two screws.

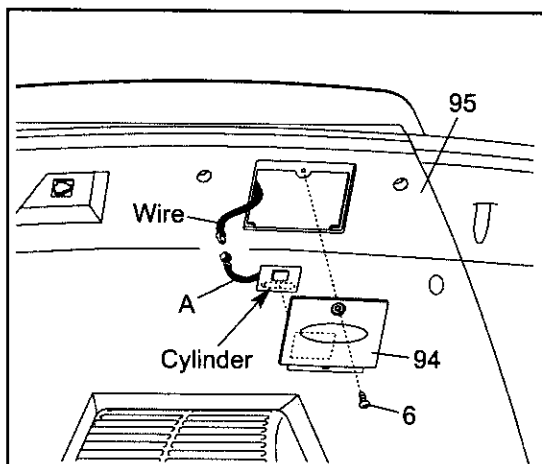

3. **Make sure that no wires are pinched.** Reattach the Access Door (94) with the 3/4" Screw (6). The other wires included with the receiver may be discarded.

TREADMILL OPERATION

THE PERFORMANT LUBE™ WALKING BELT

Your treadmill features a walking belt coated with PERFORMANT LUBE™, a high-performance lubricant. **IMPORTANT:** Never apply silicone spray or other substances to the walking belt or the walking platform. Such substances will deteriorate the walking belt and cause excessive wear.

HOW TO PLUG IN THE POWER CORD

⚠ DANGER: Improper connection of the equipment-grounding conductor can result in an increased risk of electric shock. Check with a qualified electrician or service man if you are in doubt as to whether the product is properly grounded. Do not modify the plug provided with the product—if it will not fit the outlet, have a proper outlet installed by a qualified electrician.

Your treadmill, like any other type of sophisticated electronic equipment, can be seriously damaged by sudden voltage changes in your home's power. Voltage surges, spikes, and noise interference can result from weather conditions or from other appliances being turned on or off. **To decrease the possibility of your treadmill being damaged, always use a surge suppressor with your treadmill (see drawing 1 at the right).** To purchase a surge suppressor, see your local Sears or call 1-800-366-7278 and order part number 146148.

Use only a single-outlet surge suppressor that is UL 1449 listed as a transient voltage surge suppressor (TVSS). The surge suppressor must have a UL suppressed voltage rating of 400 volts or less and a minimum surge dissipation of 450 joules. The surge suppressor must be electrically rated for 120 volts AC and 15 amps. There must be a monitoring light on the surge suppressor to indicate whether it is functioning properly. Failure to use a properly functioning surge suppressor could result in damage to the control system of the treadmill. If the control system is damaged, the walking belt may change speed or stop unexpectedly, which may result in a fall and serious injury.

This product must be grounded. If it should malfunction or break down, grounding provides a path of least resistance for electric current to reduce the risk of electric shock. This product is equipped with a cord having

an equipment-grounding conductor and a grounding plug. **Plug the power cord into a surge suppressor, and plug the surge suppressor into an appropriate outlet that is properly installed and grounded in accordance with all local codes and ordinances. Important: The treadmill is not compatible with GFCI-equipped outlets.**

This product is for use on a nominal 120-volt circuit, and has a grounding plug that looks like the plug illustrated in drawing 1 below. A temporary adapter that looks like the adapter illustrated in drawing 2 may be used to connect the surge suppressor to a 2-pole receptacle as shown in drawing 2 if a properly grounded outlet is not available.

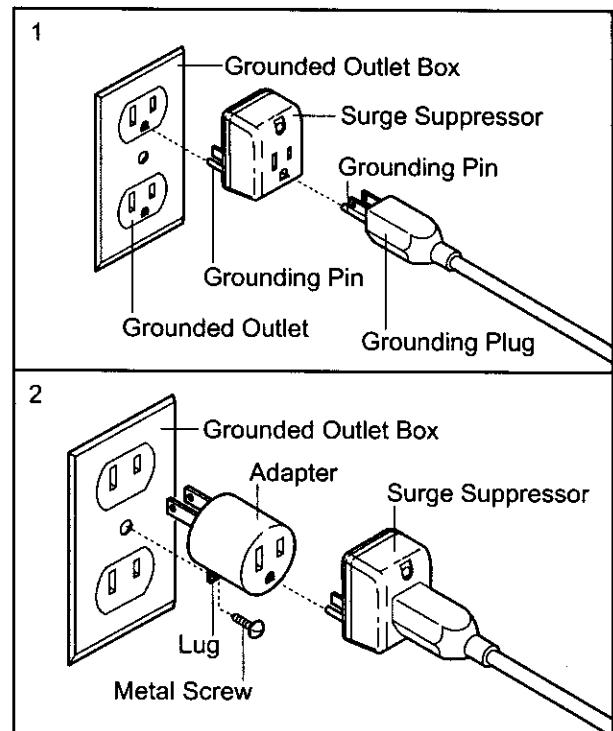

The temporary adapter should be used only until a properly grounded outlet (drawing 1) can be installed by a qualified electrician.

The green-colored rigid ear, lug, or the like extending from the adapter must be connected to a permanent ground such as a properly grounded outlet box cover. Whenever the adapter is used it must be held in place by a metal screw. **Some 2-pole receptacle outlet box covers are not grounded. Contact a qualified electrician to determine if the outlet box cover is grounded before using an adapter.**

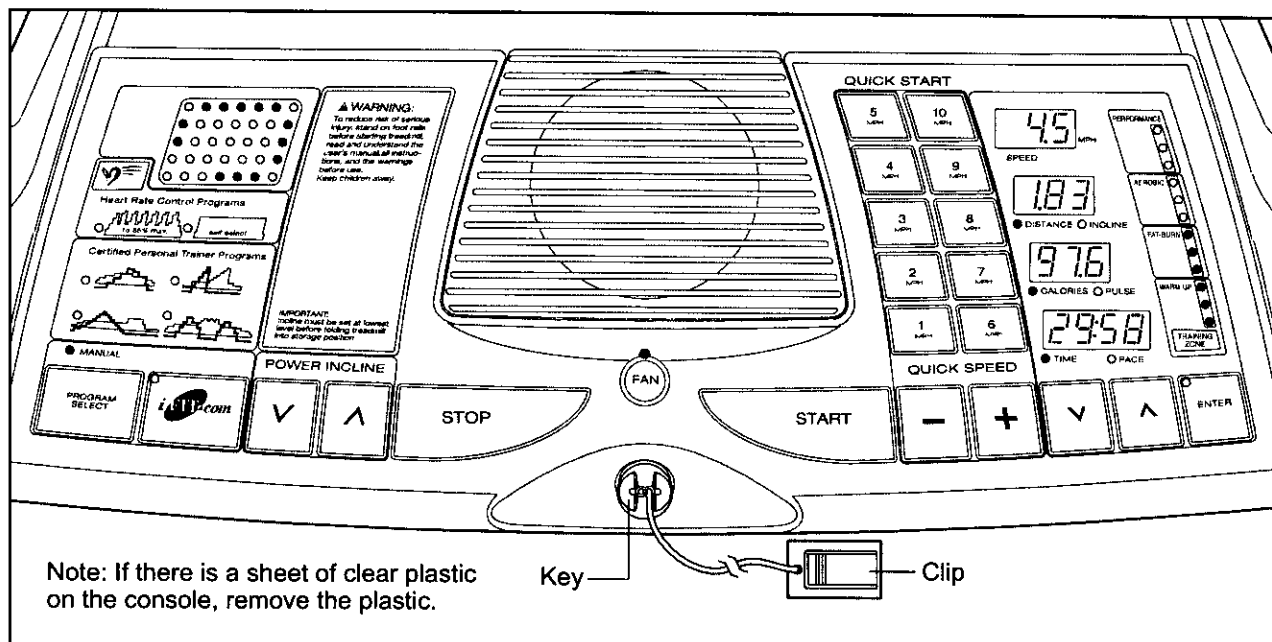

FEATURES OF THE CONSOLE

The treadmill console offers an impressive array of features that help you get the most from your workouts.

When the manual mode of the console is selected, the speed and incline of the treadmill can be changed with the touch of a button. As you exercise, the console will display instant exercise feedback. You can even measure your heart rate using the handgrip pulse sensor or the optional chest pulse sensor (see page 23).

In addition, the console offers four preset programs. Each program automatically controls the speed and incline of the treadmill as it guides you through an effective workout. Two heart rate programs are also offered. Each program automatically adjusts the speed and incline of the treadmill to keep your heart rate near a target heart rate while you exercise.

The console also features iFIT.com interactive technology. Having iFIT.com technology is like having a personal trainer in your home. Using the included audio

cable, you can connect the treadmill to your home stereo, portable stereo, computer, or VCR and play special iFIT.com CD and video programs (iFIT.com CDs and videocassettes are available separately). iFIT.com CD and video programs automatically control the speed and incline of the treadmill as a personal trainer guides you through every step of your workout. High-energy music provides added motivation. **To purchase iFIT.com CDs or videocassettes, call toll-free 1-800-735-0768.**

With the treadmill connected to your computer, you can also go to our Web site at www.iFIT.com and access programs directly from the internet. Additional options are soon to be available. **See www.iFIT.com for more information.**

To use the manual mode of the console, follow the steps beginning on page 12. To use a preset program, see page 14. To use a heart rate program, see page 16. To use an iFIT.com CD or video program, see page 20. To use iFIT.com programs directly from our Web site, see page 22.

HOW TO TURN ON THE POWER

1 Plug in the power cord (see page 10).

2 Locate the reset/off circuit breaker near the power cord. Make sure that the circuit breaker is in the reset position.

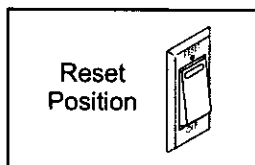

3 Stand on the foot rails of the treadmill. Find the clip attached to the key (see the drawing on page 11) and slide the clip onto the waistband of your clothes. Next, route the cord attached to the clip **under the handgrip pulse sensor**, and insert the key into the console. After a moment, the displays and various indicators will light. **Test the clip by carefully taking a few steps backward until the key is pulled from the console. If the key is not pulled from the console, adjust the position of the clip.**

HOW TO USE THE MANUAL MODE

1 Insert the key fully into the console.

See HOW TO TURN ON THE POWER above.

2 Select the manual mode.

When the key is inserted, the manual mode will be selected and the Manual indicator will light. If a program has been

selected, press the Program Select button repeatedly to reselect the manual mode.

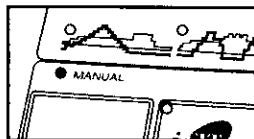

3 Press the Start button or the Speed increase button to start the walking belt.

A moment after the button is pressed, the walking belt will begin to move at 1 mph. Hold the handrails and begin

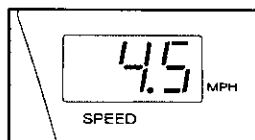

walking. As you exercise, change the speed of the walking belt as desired by pressing the Speed increase and decrease buttons. Each time a button is pressed, the speed setting will change by 0.1 mph; if a button is held down, the speed setting will change in increments of 0.5 mph. To change the speed setting quickly, press the Quick Start buttons.

To stop the walking belt, press the Stop button. The Time/Pace display will begin to flash. To restart the walking belt, press the Start button or the Speed increase button.

Note: The first time the treadmill is used, observe the alignment of the walking belt, and align the walking belt if necessary (see page 27).

4 Change the incline of the treadmill as desired.

To change the incline of the treadmill, press the Incline buttons. Each time a button is pressed, the incline will change by 0.5%. Note: After the buttons are pressed, it may take a moment for the treadmill to reach the selected incline setting.

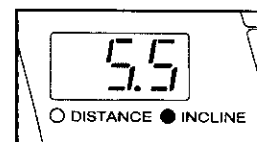

5 Follow your progress with the matrix, the training zone bar, and the displays.

The matrix—When the manual mode or the iFIT.com mode is selected, the matrix will display a 1/4-mile track. As you exercise, the indicators around the track will light in succession until the entire track is lit. The track will then darken and the indicators will again begin to light in succession.

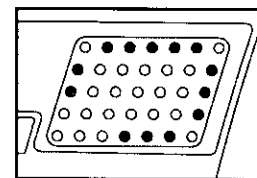

The training zone bar—The training zone bar shows the approximate intensity level of your exercise. For example, if three to six indicators in the bar are lit, the bar shows that your pace is ideal for fat burning.

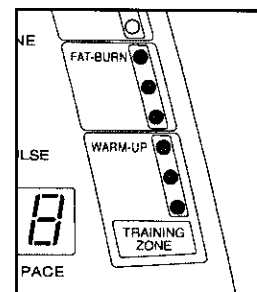

Speed display—This display shows the speed of the walking belt.



Note: The console can display speed and distance in either miles or kilometers. To find which unit of measurement is selected, press the Stop button while inserting the key into the console. An "E" for English miles or an "M" for metric kilometers will appear in the display. Press the Speed increase button to change the unit of measurement. When the desired unit of measurement is selected, remove the key and then reinsert it.

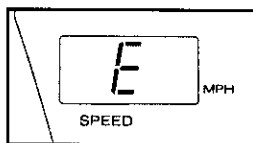

Note: For simplicity, all instructions in this manual refer to miles.

Distance/Incline display—This display shows the distance that you have walked or run and the incline level of the treadmill. The display will change from one number to the other every few seconds. Note: Each time the incline changes, the display will show the incline setting for several seconds.

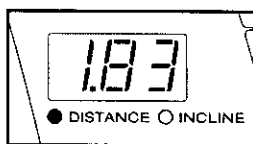

Calories/Pulse display—This display shows the approximate number of calories you have burned. The display will also show your heart rate when you use the handgrip pulse sensor or the chest pulse sensor. The display will change from one number to the other every few seconds.

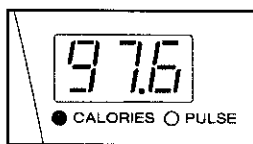

Time/Pace display—When the manual mode or the iFIT.com mode is selected, this display will show the elapsed time and your current pace (pace is measured in *minutes per mile*). The display will change from one number to the other every few seconds. When a program is selected (except for the Self Select heart rate program), the display will show the time *remaining* in the program rather than the elapsed time.

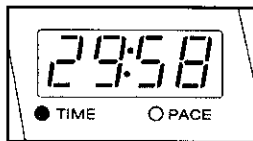

To reset the displays, press the Stop button, remove the key, and then reinsert the key.

6 Measure your heart rate if desired.

To use the handgrip pulse sensor, first make sure that your hands are clean. Next, **stand on the foot rails** and hold the pulse bar with your palms on the metal contacts.

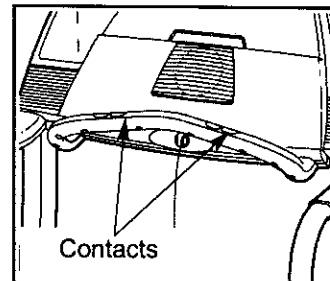

Avoid moving your hands. When your pulse is detected, two dashes (--) will appear in the Calories/Pulse display, and then your heart rate will be shown. **For the most accurate heart rate reading, continue to hold the contacts for about 15 seconds.**

Note: The pulse bar is intended to be used only for heart rate measurement. **Do not use the pulse bar as a handlebar. Always hold the handrails for support when you are not measuring your heart rate.**

7 Turn on the fan if desired.

To turn on the fan, press the Fan button. To turn on the fan at high speed, press the button a second time. To turn off the fan, press the button a third time. Note: A few minutes after the walking belt is stopped, the fan will automatically turn off.

8 When you are finished exercising, remove the key from the console.

Step onto the foot rails, press the Stop button, and **adjust the incline of the treadmill to the lowest setting. The incline must be at the lowest setting when the treadmill is folded to the storage position or the treadmill will be damaged.** Next, remove the key from the console and put it in a secure place. **Note: If the displays and various indicators on the console remain lit after the key is removed, the console is in the "demo" mode. See page 23 and turn off the demo mode.**

When you are finished using the treadmill, switch the reset/off circuit breaker to the off position and unplug the power cord.

HOW TO USE PRESET PROGRAMS

1 Insert the key fully into the console.

See HOW TO TURN ON THE POWER on page 12.

2 Select one of the preset programs.

When the key is inserted, the manual mode will be selected. To select a personal trainer program, press the Program Select button repeatedly until one of the four personal trainer program indicators lights.

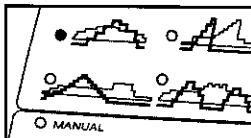

The diagrams beside the personal trainer program indicators show how the speed and incline of the treadmill will change during the programs. When a program is selected, the Speed display will flash the maximum speed setting of the program for a few seconds, and the Distance/Incline display will flash the maximum Incline setting. The Time/Pace display will show how long the program will last.

The matrix will show the first four speed settings of the program.

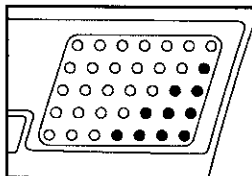

3 Press the Start button or the Speed increase button to start the program.

A moment after the button is pressed, the treadmill will automatically adjust to the first speed and incline settings of the program. Hold the handrails and begin walking.

Each program is divided into several time segments of different lengths. One speed setting and one incline setting are programmed for each segment. Note: The same speed setting and/or incline setting may be programmed for two or more consecutive segments.

The speed setting for the first segment is shown in the flashing Current Segment column of the matrix. (The incline settings are not shown in the matrix.) The speed settings for the next four segments are shown in the columns to the right.

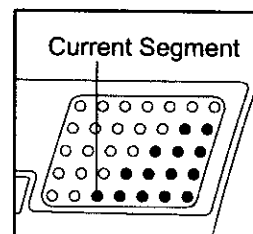

When only three seconds remain in the first segment of the program, both the Current Segment column and the column to the right will flash and a series of tones will sound. If the speed and/or incline of the treadmill is about to change, the Speed display and/or the Distance/Incline display will flash to alert you. When the first segment ends, *all speed settings will move one column to the left.* The speed setting for the second segment will then be shown in the flashing Current Segment column and the treadmill will automatically adjust to the speed and incline settings for the second segment. Note: If all of the indicators in the Current Segment column are lit after the speed settings have moved to the left, *the speed settings may move downward* so that only the highest indicators appear in the matrix. If some of the indicators in the Current Segment column are not lit when the speed settings move to the left again, the speed settings will move back up.

The program will continue in this way until the speed setting for the last segment is shown in the Current Segment column and the last segment ends. The walking belt will then slow to a stop.

If the speed or incline setting is too high or too low at any time during the program, you can manually override the setting by pressing the Speed or Incline buttons. Every few times a Speed button is pressed, an additional indicator will light or darken in the Current Segment column. (If any of the columns to the right of the Current Segment column have the same number of lit indicators as the Current Segment column, an additional indicator may light or darken in those columns as well.) **Note: When the next segment of the program begins, the treadmill will automatically adjust to the speed and incline settings for the next segment.**

To stop the program at any time, press the Stop button. The Time/Pace display will begin to flash. To restart the program, press the Start button or the Speed increase button. The walking belt will begin to move at 1 mph. When the next segment of the program begins, the treadmill will automatically adjust to the speed and incline settings for the next segment.

4 Follow your progress with the displays.

See step 5 on page 12.

5 Measure your heart rate if desired.

See step 6 on page 13.

6 Turn on the fan if desired.

See step 7 on page 13.

7 When you are finished exercising, remove the key from the console.

When the program ends, **make sure that the incline of the treadmill is at the lowest setting.** Next, remove the key from the console and put it in a secure place. **Note: If the displays and various indicators on the console remain lit after the key is removed, the console is in the "demo" mode. See page 23 and turn off the demo mode.**

When you are finished using the treadmill, switch the reset/off circuit breaker to the off position and unplug the power cord.

HOW TO USE HEART RATE PROGRAMS

CAUTION: If you have heart problems, or if you are over 60 years of age and have been inactive, do not use the heart rate programs. If you are taking medication regularly, consult your physician to find whether the medication will affect your exercise heart rate.

1 Put on the optional chest pulse sensor.

You must wear the optional chest pulse sensor (see page 23) to use a heart rate program. See the instructions included with the chest pulse sensor.

2 Insert the key fully into the console.

See HOW TO TURN ON THE POWER on page 12.

3 Select a heart rate program.

When the key is inserted, the manual mode will be selected. To select a heart rate program, press the Program Select button repeatedly until one of the two heart rate program indicators lights.

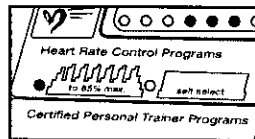

The diagrams beside the heart rate program indicators show how the target heart rate will change during the programs. During the 85% Max program, your heart rate will reach approximately 85% of your *estimated maximum heart rate*; during the Self Select program, your heart rate will remain near a level that you select. Note: Your estimated maximum heart rate is determined by subtracting your age from 220. For example, if you are 30 years old, your estimated maximum heart rate is 190 beats per minute ($220 - 30 = 190$).

During heart rate programs, the matrix will show a moving graphic that represents your heart rate. Each time a heartbeat is detected, an additional peak will appear.

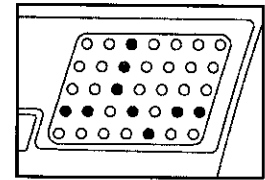

4 Enter your age.

When a heart rate program is selected, the word "AGE" and the current age setting will flash in the Calories/Pulse display. If you have already entered your age, simply press the Enter button. If you have not entered your age, press the increase and decrease buttons beside the Enter button to enter your age. Then, press the Enter button.



5 Enter a maximum speed.

After you have entered your age, the letters "SPd" and the maximum speed setting of the program will flash in the Speed display. If desired, press the increase and decrease buttons beside the Enter button to adjust the maximum speed setting. When the desired setting is shown, press the Enter button.

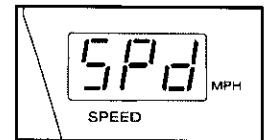

If the 85% Max program is selected, go to step 7. If the Self Select program is selected, go to step 6.

6 Enter a target heart rate.

The letters "PLS" and the target heart rate setting for the program will flash in the Calories/Pulse display. If desired, press the increase and decrease buttons beside the Enter button to adjust the target heart rate setting. When the desired setting is shown, press the Enter button.

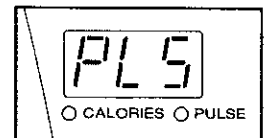

7 Press the Start button or the Speed increase button to start the program.

A moment after the button is pressed, the treadmill will automatically adjust to the first speed and incline settings of the program. Hold the handrails and begin walking.

Each heart rate program is divided into several time segments of different lengths. One target heart rate is programmed for each segment. Note: If the Self Select program is selected, the same target heart rate is programmed for all segments.

During each segment, the console will regularly compare your heart rate to the current target heart rate. If your heart rate is too far below or above the target heart rate, the speed of the treadmill will automatically increase or decrease to bring your heart rate closer to the target heart rate. If the speed reaches the maximum speed setting of the program (see step 5 on page 16) and your heart rate is still too far below the current target heart rate, the incline of the treadmill will also increase to bring your heart rate closer to the target heart rate.

During the last three seconds of each segment, a series of tones will sound and the Speed display and the Distance/Incline display will flash.

The program will continue until the last segment ends. The walking belt will then slow to a stop.

If the speed or incline setting is too high or too low at any time during the program, you can adjust the setting with the Speed or Incline buttons. However, each time the console compares your heart rate to the current target heart rate, the speed and/or incline of the treadmill may automatically change to bring your heart rate closer to the target heart rate.

If your pulse is not detected during the program, the letters "PLS" will flash in the Calories/Pulse display and the speed and incline of the treadmill may automatically decrease until your pulse is detected. If this occurs, see the instructions included with the optional chest pulse sensor.

To stop the program at any time, press the Stop button. Heart rate programs cannot be stopped temporarily and then restarted. To use a heart rate program again, reselect the program and start it at the beginning.

8 Follow your progress with the displays.

See step 5 on page 12.

9 Turn on the fan if desired.

See step 7 on page 13.

10 When you are finished exercising, remove the key from the console.

See step 7 on page 15.

HOW TO CONNECT THE TREADMILL TO YOUR CD PLAYER, VCR, OR COMPUTER

To use iFIT.com CDs, the treadmill must be connected to your portable CD player, portable stereo, home stereo, or computer with CD player. See pages 18 and 19 for connecting instructions. To use iFIT.com video-cassettes, the treadmill must be connected to your VCR. See page 20 for connecting instructions. To use iFIT.com programs directly from our internet site, the treadmill must be connected to your home computer. See page 19 for connecting instructions.

HOW TO CONNECT YOUR PORTABLE CD PLAYER

Note: If your CD player has separate LINE OUT and PHONES jacks, see instruction A below. If your CD player has only one jack, see instruction B.

- A. Plug one end of the audio cable into the jack on the front of the treadmill near the power cord. Plug the other end of the cable into the LINE OUT jack on your CD player. Plug your headphones into the PHONES jack.

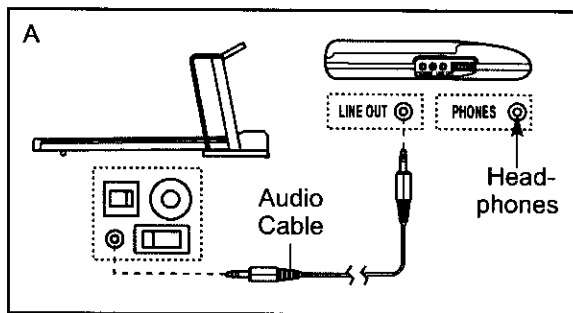

- B. Plug one end of the audio cable into the jack on the front of the treadmill near the power cord. Plug the other end of the cable into a 3.5mm Y-adapter (available at electronics stores). Plug the Y-adapter into the PHONES jack on your CD player. Plug your headphones into the other side of the Y-adapter.

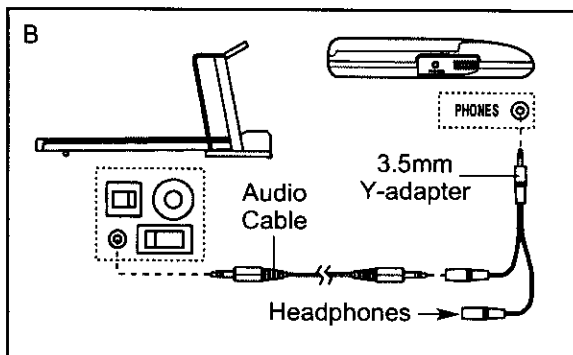

HOW TO CONNECT YOUR PORTABLE STEREO

Note: If your stereo has an RCA-type AUDIO OUT jack, see instruction A below. If your stereo has a 3.5mm LINE OUT jack, see instruction B. If your stereo has only a PHONES jack, see instruction C.

- A. Plug one end of the audio cable into the jack on the front of the treadmill near the power cord. Plug the other end of the cable into the included adapter. Plug the adapter into an AUDIO OUT jack on your stereo.

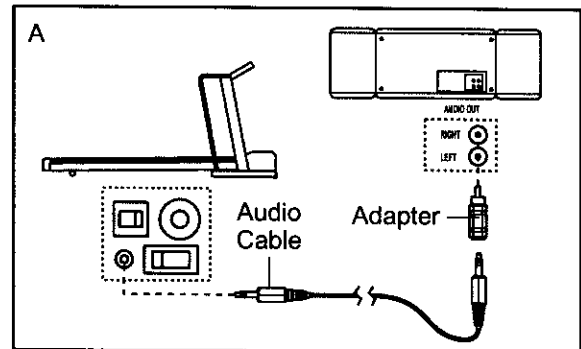

- B. Plug one end of the audio cable into the jack on the front of the treadmill near the power cord. Plug the other end of the cable into the LINE OUT jack on your stereo.

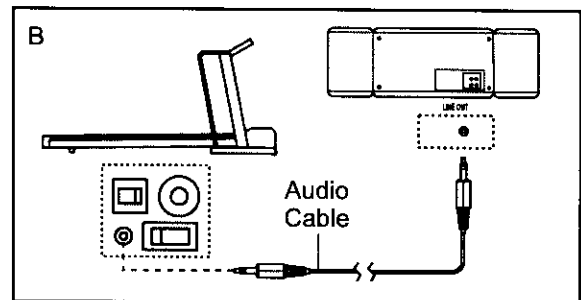

- C. Plug one end of the audio cable into the jack on the front of the treadmill near the power cord. Plug the other end of the cable into a 3.5mm Y-adapter (available at electronics stores). Plug the Y-adapter into the PHONES jack on your stereo. Plug your headphones into the other side of the Y-adapter.

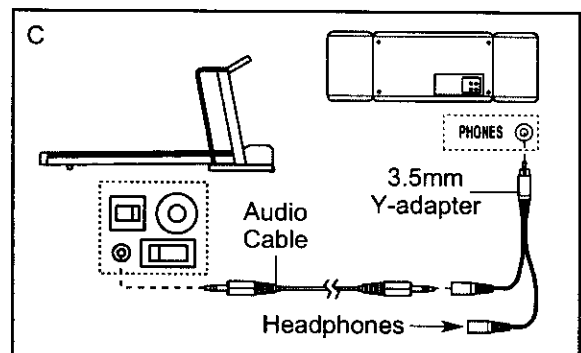

HOW TO CONNECT YOUR HOME STEREO

Note: If your stereo has an unused LINE OUT jack, see instruction A below. If the LINE OUT jack is being used, see instruction B.

- A. Plug one end of the audio cable into the jack on the front of the treadmill near the power cord. Plug the other end of the cable into the included adapter. Plug the adapter into the LINE OUT jack on your stereo.

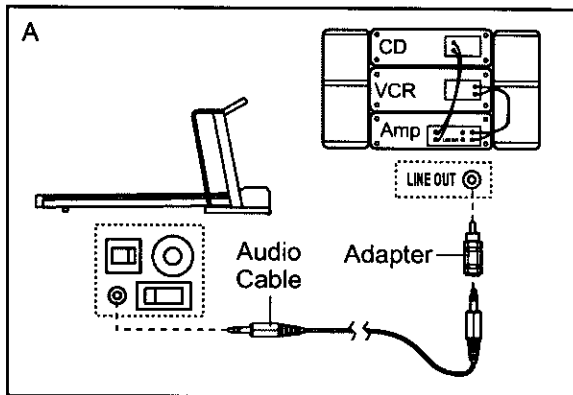

- B. Plug one end of the audio cable into the jack on the front of the treadmill near the power cord. Plug the other end of the cable into the included adapter. Plug the adapter into an RCA Y-adapter (available at electronics stores). Next, remove the wire that is currently plugged into the LINE OUT jack on your stereo and plug the wire into the unused side of the Y-adapter. Plug the Y-adapter into the LINE OUT jack on your stereo.

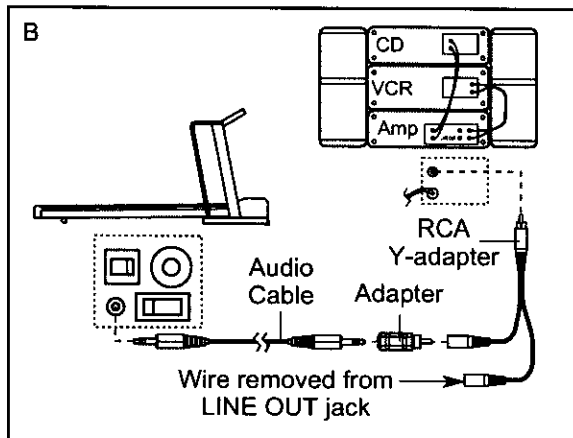

HOW TO CONNECT YOUR COMPUTER

Note: If your computer has a 3.5mm LINE OUT jack, see instruction A. If your computer has only a PHONES jack, see instruction B.

- A. Plug one end of the audio cable into the jack on the front of the treadmill near the power cord. Plug the other end of the cable into the LINE OUT jack on your computer.

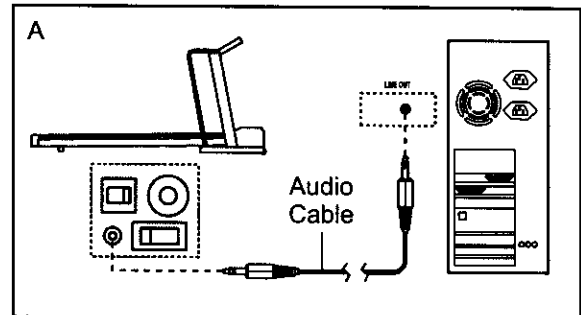

- B. Plug one end of the audio cable into the jack on the front of the treadmill near the power cord. Plug the other end of the cable into a 3.5mm Y-adapter (available at electronics stores). Plug the Y-adapter into the PHONES jack on your computer. Plug your headphones or speakers into the other side of the Y-adapter.

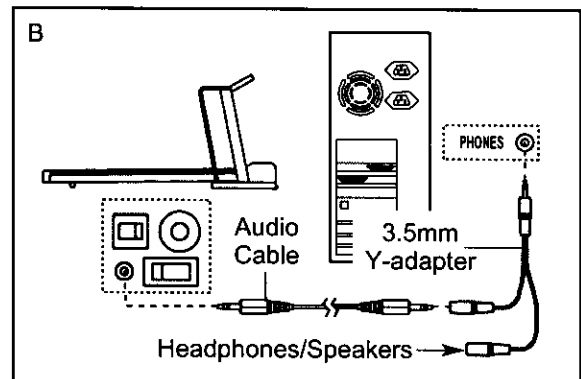

HOW TO CONNECT YOUR VCR

Note: If your VCR has an unused AUDIO OUT jack, see instruction A below. If the AUDIO OUT jack is being used, see instruction B. If you have a TV with a built-in VCR, see instruction B. If your VCR is connected to your home stereo, see **HOW TO CONNECT YOUR HOME STEREO** on page 19.

- A. Plug one end of the audio cable into the jack on the front of the treadmill near the power cord. Plug the other end of the cable into the included adapter. Plug the adapter into the AUDIO OUT jack on your VCR.

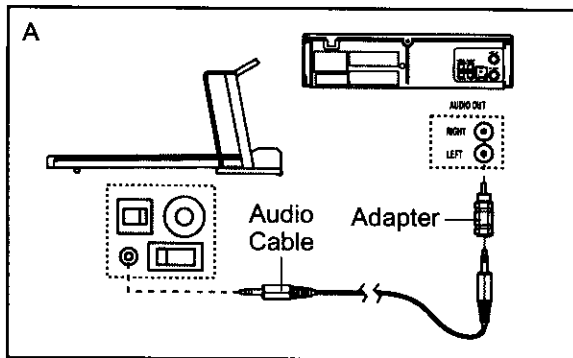

- B. Plug one end of the audio cable into the jack on the front of the treadmill near the power cord. Plug the other end of the cable into the included adapter. Plug the adapter into an RCA Y-adapter (available at electronics stores). Next, remove the wire that is currently plugged into the AUDIO OUT jack on your VCR and plug the wire into the unused side of the Y-adapter. Plug the Y-adapter into the AUDIO OUT jack on your VCR.

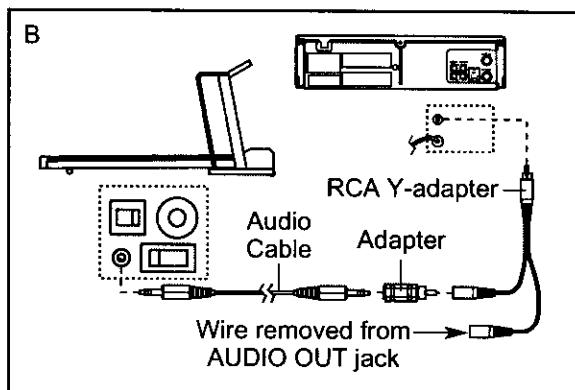

HOW TO USE iFIT.COM CD AND VIDEO PROGRAMS

To use iFIT.com CDs or videocassettes, the treadmill must be connected to your portable CD player, portable stereo, home stereo, computer with CD player, or VCR. See **HOW TO CONNECT THE TREADMILL TO YOUR CD PLAYER, VCR, OR COMPUTER** on pages 18 to 20. **Note:** To purchase iFIT.com CDs or videocassettes, call toll-free 1-800-735-0768.

Follow the steps below to use an iFIT.com CD or video program.

1 Insert the key into the console.

See **HOW TO TURN ON THE POWER** on page 12.

2 Select the iFIT.com mode.

When the key is inserted, the manual mode will be selected. To use iFIT.com CDs or videocassettes, press the iFIT.com button. The indicator on the button will light.

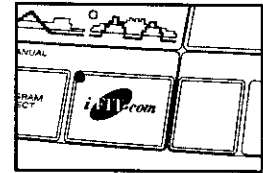

3 Insert the iFIT.com CD or videocassette.

If you are using an iFIT.com CD, insert the CD into your CD player. If you are using an iFIT.com videocassette, insert the videocassette into your VCR.

4 Press the PLAY button on your CD player or VCR.

A moment after the button is pressed, your personal trainer will begin guiding you through your workout. Simply follow your personal trainer's instructions. **Note:** If the Time/Pace display is flashing, press the Start button or the Speed increase button on the console. The treadmill will not respond to a CD or video program while the Time/Pace display is flashing.

During the CD or video program, an electronic "chirping" sound will alert you when the speed and/or incline of the treadmill is about to change. **CAUTION: Always listen for the "chirp" and be prepared for speed and/or incline changes. In some instances, the speed and/or incline may change before the personal trainer describes the change.**

If the speed or incline settings are too high or too low, you can manually override the settings at any time by pressing the Speed or Incline buttons on the console. However, **when the next “chirp” is heard, the speed and/or incline will change to the next settings of the CD or video program.**

To stop the walking belt at any time, press the Stop button on the console. The Time/Pace display will begin to flash. To restart the program, press the Start button or the Speed increase button. After a moment, the walking belt will begin to move at 1 mph. **When the next “chirp” is heard, the speed and incline will change to the next settings of the CD or video program.**

When the CD or video program is completed, the walking belt will stop and the Time/Pace display will begin to flash. Note: To use another CD or video program, press the Stop button or remove the key and go to step 1 on page 20.

Note: If the speed or incline of the treadmill does not change when a “chirp” is heard:

- **Make sure that the iFIT.com indicator is lit and that the Time/Pace display is not flashing. If the Time/Pace display is flashing, press the Start button or the Speed increase button on the console.**
- **Adjust the volume of your CD player or VCR. If the volume is too high or too low, the console may not detect the program signals.**

- **Make sure that the audio cable is properly connected, that it is fully plugged in, and that it is not wrapped around a power cord.**

- **If you are using your portable CD player and the CD skips, set the CD player on the floor or another flat surface instead of on the console.**

5 Follow your progress with the matrix, the training zone bar, and the displays.

See step 5 on page 12.

6 Measure your heart rate if desired.

See step 6 on page 13.

7 Turn on the fan if desired.

See step 7 on page 13.

8 When you are finished exercising, remove the key from the console.

See step 7 on page 15.

CAUTION: Always remove iFIT.com CDs and videocassettes from your CD player and VCR when you are finished using them.

HOW TO USE PROGRAMS DIRECTLY FROM OUR WEB SITE

To use programs from our Web site, the treadmill must be connected to your home computer. See HOW TO CONNECT YOUR COMPUTER on page 19. In addition, you must have an internet connection and an internet service provider. A list of specific system requirements is found on our Web site.

Follow the steps below to use a program from our Web site.

1 Insert the key into the console.

See HOW TO TURN ON THE POWER on page 12.

2 Select the iFIT.com mode.

When the key is inserted, the manual mode will be selected. To use a program from our Web site, press the iFIT.com button. The indicator on the button will light.

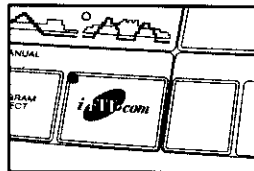

3 Go to your computer and start an internet connection.

4 Start your web browser, if necessary, and go to our Web site at www.iFIT.com.

5 Follow the desired links on our Web site to select a program.

Read and follow the on-line instructions for using a program.

6 Follow the on-line instructions to start the program.

When you start the program, an on-screen countdown will begin.

7 Return to the treadmill and stand on the foot pads. Find the clip attached to the key and slide the clip onto the waistband of your clothes.

When the on-screen countdown ends, the program will begin and the walking belt will begin to move.

Hold the handrails, step onto the walking belt, and begin walking. During the program, an electronic “chirping” sound will alert you when the speed and/or incline of the treadmill is about to change. **CAUTION: Always listen for the “chirp” and be prepared for speed and/or incline changes.**

If the speed or incline settings are too high or too low, you can manually override the settings at any time by pressing the Speed or Incline buttons on the console. **However, when the next “chirp” is heard, the speed and/or incline will change to the next settings of the program.**

To stop the walking belt at any time, press the Stop button on the console. The Time/Pace display will begin to flash. To restart the program, press the Start button or the Speed increase button. After a moment, the walking belt will begin to move at 1 mph. **When the next “chirp” is heard, the speed and incline will change to the next settings of the program.**

When the program is completed, the walking belt will stop and the Time/Pace display will begin to flash. Note: To use another program, press the Stop button and go to step 5.

Note: If the speed or incline of the treadmill does not change when a “chirp” is heard, make sure that the iFIT.com indicator is lit and that the Time/Pace display is not flashing. In addition, make sure that the audio cable is properly connected, that it is fully plugged in, and that it is not wrapped around a power cord.

8 Follow your progress with the matrix, the training zone bar, and the displays.

See step 5 on page 12.

9 When you are finished exercising, remove the key from the console.

See step 7 on page 15.

THE INFORMATION MODE/DEMO MODE

The console features an information mode that keeps track of total number of miles that the walking belt has moved and the total number of hours that the treadmill has been used. The information mode also allows you to switch the console from miles to kilometers. In addition, the information mode allows you to turn on and turn off the demo mode.

To select the information mode, hold down the Stop button while inserting the key into the console. When the information mode is selected, the following information will be shown:

An "E" for English miles or an "M" for metric kilometers will appear in the Speed display. Press the Speed increase button to change the unit of measurement.

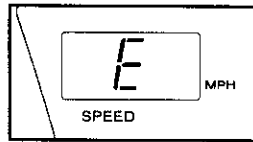

The Distance/Incline display will show the total number of miles (or kilometers) that the walking belt has moved.

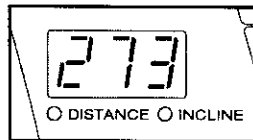

The Time/Pace display will show the total number of hours the treadmill has been used.

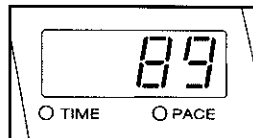

IMPORTANT: The Calories/Pulse display should be blank. If a "d" appears in the display, the console is in the "demo" mode. This mode is intended to be used only when a treadmill is displayed in a store. When the console is in the demo mode, the power cord can be plugged in, the key can be removed from the console, and the displays and indicators on the console will automatically light in a preset sequence, although the buttons on the console will not operate. **If a "d" appears in the Calories/Pulse display when the information mode is selected, press the Speed decrease button so the display is blank.**

To exit the information mode, remove the key from the console.

THE OPTIONAL CHEST PULSE SENSOR

An optional chest pulse sensor adds even more features to the console. The chest pulse sensor provides hands-free operation and allows the console's heart rate programs to be used. **To purchase the optional chest pulse sensor, call toll-free 1-800-734-2377.**

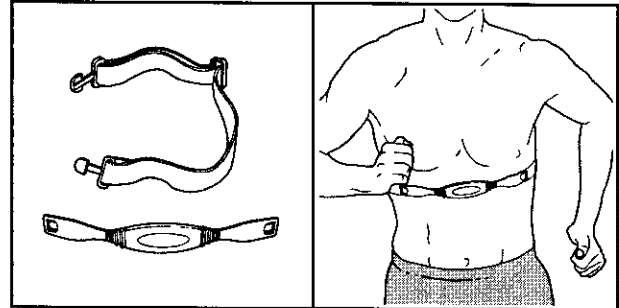

HOW TO FOLD AND MOVE THE TREADMILL

HOW TO FOLD THE TREADMILL FOR STORAGE

Before folding the treadmill, adjust the incline to the lowest position. If this is not done, the treadmill may be permanently damaged. Next, unplug the power cord. **CAUTION:** You must be able to safely lift 45 pounds (20 kg) to raise, lower, or move the treadmill.

1. Hold the treadmill in the locations shown at the right. To decrease the possibility of injury, bend your legs and keep your back straight. As you raise the treadmill, make sure to lift with your legs rather than your back. Raise the treadmill about halfway to the vertical position.

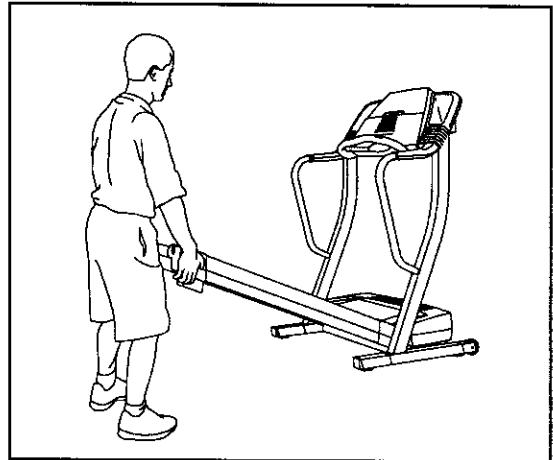

2. Hold the treadmill frame firmly with your left hand. Using your right hand, pull the latch knob to the right and hold it. Raise the treadmill until the pin on the latch knob is aligned with the hole in the left handgrip. Then, release the latch knob. **Make sure that the latch knob is fully released so that the pin is fully inserted into the hole in the left handgrip.** Note: After a period of use, the latch housing may need to be adjusted to align the pin with the hole in the left handgrip (see assembly step 5 on page 8).

To protect the floor or carpet from damage, place a mat under the treadmill. Keep the treadmill out of direct sunlight. Do not leave the treadmill in the storage position in temperatures above 85° Fahrenheit.

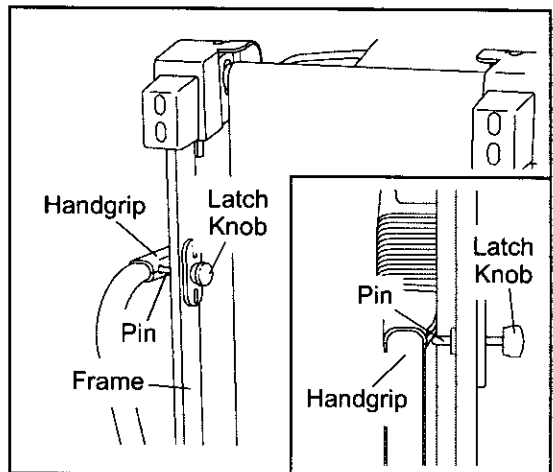

HOW TO MOVE THE TREADMILL

Before moving the treadmill, convert the treadmill to the storage position as described above. **Make sure that the pin on the latch knob is fully inserted into the hole in the left handgrip.**

1. Hold the treadmill and place one foot on the base.
2. Tilt the treadmill back until it rolls freely on the wheels. Carefully move the treadmill to the desired location. **To reduce the risk of injury, use extreme caution while moving the treadmill. Do not attempt to move the treadmill over an uneven surface.**
3. Place one foot on the wheel, and carefully lower the treadmill until the base is resting in the storage position.

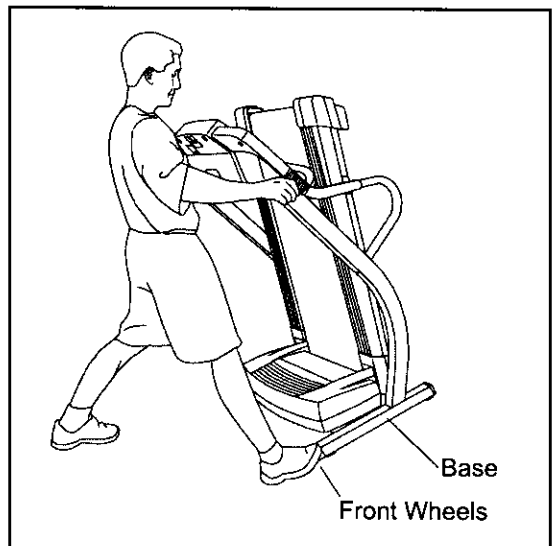

HOW TO LOWER THE TREADMILL FOR USE

1. Hold the treadmill frame firmly with your left hand. Pull the latch knob to the right. Pivot the treadmill down until the pin on the latch knob is below the handgrip. Slowly release the latch knob.

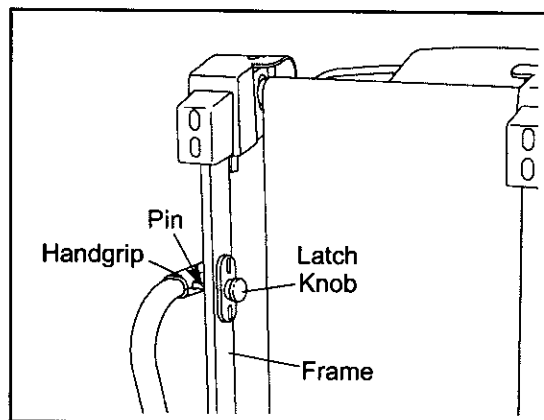

2. Hold the treadmill firmly with both hands, and lower the treadmill to the floor. **To decrease the possibility of injury, bend your legs and keep your back straight.**

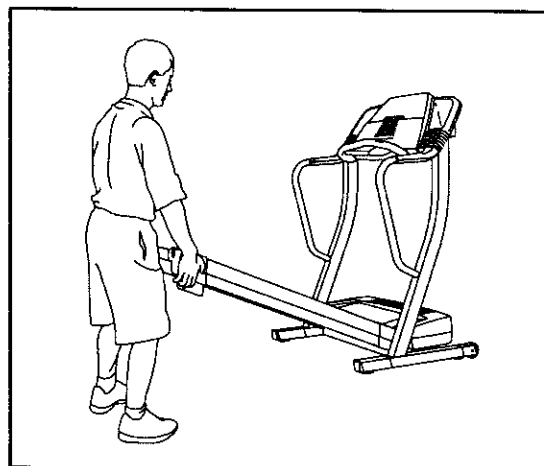

TROUBLESHOOTING

Most treadmill problems can be solved by following the simple steps below. Find the symptom that applies, and follow the steps listed. If further assistance is needed, call toll-free 1-800-4-MY-HOME® (1-800-469-4663).

PROBLEM: The power does not turn on

SOLUTION: a. Make sure that the power cord is plugged into a surge suppressor, and that the surge suppressor is plugged into a properly grounded outlet (see page 10). Use only a single-outlet surge suppressor that meets all of the specifications described on page 10. Important: The treadmill is not compatible with GFCI-equipped outlets.

b. Make sure that the key is fully inserted into the console.

c. Check the reset/off circuit breaker located on the frame near the power cord. If the breaker protrudes as shown, the circuit breaker has tripped. To reset the circuit breaker, wait for five minutes and then press the breaker back in.

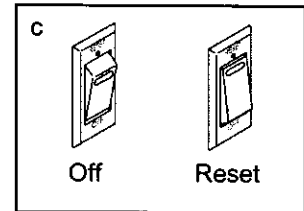

PROBLEM: The power turns off during use

SOLUTION: a. Check the reset/off circuit breaker located on the treadmill frame near the power cord (see 1. c. above). If the circuit breaker has tripped, wait for five minutes and then press the switch back in.

b. Make sure that the power cord is plugged in. If the power cord is plugged in, unplug it, wait for five minutes, and then plug it back in.

c. Remove the key from the console and then reinsert it.

d. If the treadmill still will not run, please call toll-free 1-800-4-MY-HOME® (1-800-469-4663).

PROBLEM: The displays of the console do not function properly

SOLUTION: a. Remove the key from the console and **UNPLUG THE POWER CORD**. With the help of another person, carefully tip the Base (109) down as shown. Remove the two 3/4" Screws (6) and the two 3/4" Tek Screws (47). (Note: Your treadmill may not have 3/4" Tek Screws.) A phillips screwdriver with at least a 5" shaft is required.

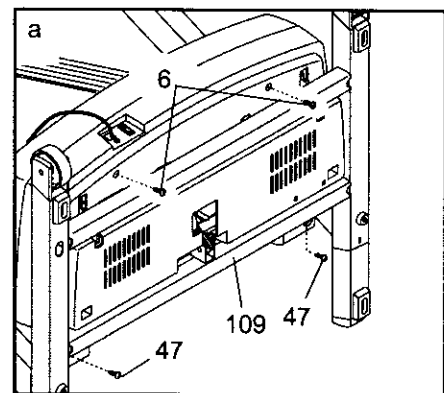

With the help of another person, carefully raise the Uprights (69) as shown. Carefully pivot the Hood (39) off.

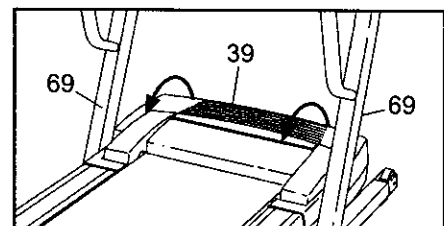

Locate the Reed Switch (24) and the Magnet (18) on the left side of the Pulley (120). Turn the Pulley until the Magnet is aligned with the Reed Switch. **Make sure that the gap between the Magnet and the Reed Switch is about 1/8".** If necessary, loosen the Screw (25), move the Reed Switch slightly, and then retighten the Screw. Reattach the Hood (not shown). Make sure that the Screws are returned to the correct holes (see drawing A). Run on the treadmill for a few minutes to check for a correct speed reading.

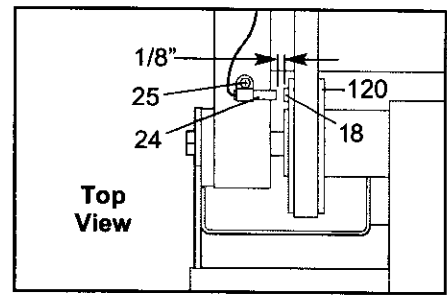

PROBLEM: The walking belt slows when walked on

SOLUTION: a. Use only a single-outlet surge suppressor that meets all of the specifications described on page 10.

b. If the walking belt is overtightened, treadmill performance may decrease and the walking belt may be permanently damaged. Remove the key and **UNPLUG THE POWER CORD**. Using the included allen wrench, turn both rear roller adjustment bolts counterclockwise 1/4 of a turn. When the walking belt is properly tightened, you should be able to lift the edges of the walking belt 3 to 4 inches off the walking platform. Be careful to keep the walking belt centered. Plug in the power cord, insert the key, and run the treadmill for a few minutes. Repeat until the walking belt is properly tightened.

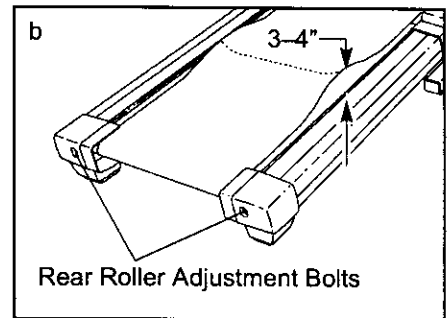

c. If the walking belt still slows when walked on, please call toll-free 1-800-4-MY-HOME® (1-800-469-4663).

PROBLEM: The walking belt is off-center or slips when walked on

SOLUTION: a. If the walking belt is off-center, first remove the key and **UNPLUG THE POWER CORD**. If the walking belt has shifted to the left, use the allen wrench to turn the left rear roller bolt clockwise 1/2 of a turn; if the walking belt has shifted to the right, turn the left bolt counterclockwise 1/2 of a turn. Be careful not to overtighten the walking belt. Plug in the power cord, insert the key, and run the treadmill for a few minutes. Repeat until the walking belt is centered.

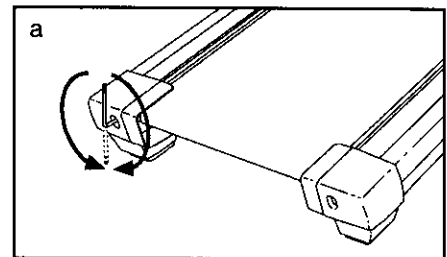

b. If the walking belt slips when walked on, first remove the key and **UNPLUG THE POWER CORD**. Using the allen wrench, turn both rear roller bolts clockwise 1/4 of a turn. When the walking belt is correctly tightened, you should be able to lift each side of the walking belt 3 to 4 inches off the walking platform. Be careful to keep the walking belt centered. Plug in the power cord, insert the key, and walk on the treadmill for a few minutes. Repeat until the walking belt is properly tightened.

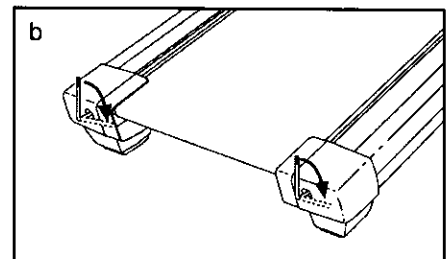

EXERCISE GUIDELINES

⚠ WARNING: Before beginning this or any exercise program, consult your physician. This is especially important for individuals over the age of 35 or individuals with pre-existing health problems.

The pulse sensor is not a medical device. Various factors, including the user's movement, may affect the accuracy of heart rate readings. The pulse sensor is intended only as an exercise aid in determining heart rate trends in general.

The following guidelines will help you to plan your exercise program. For more detailed exercise information, obtain a reputable book or consult your physician.

EXERCISE INTENSITY

Whether your goal is to burn fat or to strengthen your cardiovascular system, the key to achieving the desired results is to exercise with the proper intensity. The proper intensity level can be found by using your heart rate as a guide. The chart below shows recommended heart rates for fat burning and aerobic exercise.

HEART RATE TRAINING ZONES							
AEROBIC	165	155	145	140	130	125	115
MAX FAT BURN	145	138	130	125	118	110	103
FAT BURN	125	120	115	110	105	95	90
Age	20	30	40	50	60	70	80

To find the proper heart rate for you, first find your age near the bottom of the chart (ages are rounded off to the nearest ten years). Next, find the three numbers above your age. The three numbers define your "training zone." The lower two numbers are recommended heart rates for fat burning; the highest number is the recommended heart rate for aerobic exercise.

To measure your heart rate during exercise, use the handgrip pulse sensor.

Fat Burning

To burn fat effectively, you must exercise at a relatively low intensity level for a sustained period of time. During the first few minutes of exercise, your body uses easily accessible *carbohydrate calories* for en-

ergy. Only after the first few minutes does your body begin to use stored *fat calories* for energy. If your goal is to burn fat, adjust the speed or incline of the treadmill until your heart rate is near the lowest number in your training zone.

For maximum fat burning, adjust the speed or incline of the treadmill until your heart rate is near the middle number in your training zone.

Aerobic Exercise

If your goal is to strengthen your cardiovascular system, your exercise must be "aerobic." Aerobic exercise is activity that requires large amounts of oxygen for prolonged periods of time. This increases the demand on the heart to pump blood to the muscles, and on the lungs to oxygenate the blood. For aerobic exercise, adjust the speed or incline of the treadmill until your heart rate is near the highest number in your training zone.

WORKOUT GUIDELINES

Each workout should include the following three parts:

A Warm-up—Start each workout with 5 to 10 minutes of stretching and light exercise. A proper warm-up increases your body temperature, heart rate and circulation in preparation for exercise.

Training Zone Exercise—After warming up, increase the intensity of your exercise until your pulse is in your training zone for 20 to 60 minutes. (During the first few weeks of your exercise program, do not keep your pulse in your training zone for longer than 20 minutes.) Breathe regularly and deeply as you exercise—never hold your breath.

A Cool-down—Finish each workout with 5 to 10 minutes of stretching to cool down. This will increase the flexibility of your muscles and will help prevent post-exercise problems.

EXERCISE FREQUENCY

To maintain or improve your condition, complete three workouts each week, with at least one day of rest between workouts. After a few months, you may complete up to five workouts each week if desired. The key to success is to make exercise a regular and enjoyable part of your everyday life.

SUGGESTED STRETCHES

The correct form for several basic stretches is shown at the right. Move slowly as you stretch—never bounce.

1. Toe Touch Stretch

Stand with your knees bent slightly and slowly bend forward from your hips. Allow your back and shoulders to relax as you reach down toward your toes as far as possible. Hold for 15 counts, then relax. Repeat 3 times. Stretches: Hamstrings, back of knees and back.

2. Hamstring Stretch

Sit with one leg extended. Bring the sole of the opposite foot toward you and rest it against the inner thigh of your extended leg. Reach toward your toes as far as possible. Hold for 15 counts, then relax. Repeat 3 times for each leg. Stretches: Hamstrings, lower back and groin.

3. Calf/Achilles Stretch

With one leg in front of the other, reach forward and place your hands against a wall. Keep your back leg straight and your back foot flat on the floor. Bend your front leg, lean forward and move your hips toward the wall. Hold for 15 counts, then relax. Repeat 3 times for each leg. To cause further stretching of the achilles tendons, bend your back leg as well. Stretches: Calves, achilles tendons and ankles.

4. Quadriceps Stretch

With one hand against a wall for balance, reach back and grasp one foot with your other hand. Bring your heel as close to your buttocks as possible. Hold for 15 counts, then relax. Repeat 3 times for each leg. Stretches: Quadriceps and hip muscles.

5. Inner Thigh Stretch

Sit with the soles of your feet together and your knees outward. Pull your feet toward your groin area as far as possible. Hold for 15 counts, then relax. Repeat 3 times. Stretches: Quadriceps and hip muscles.

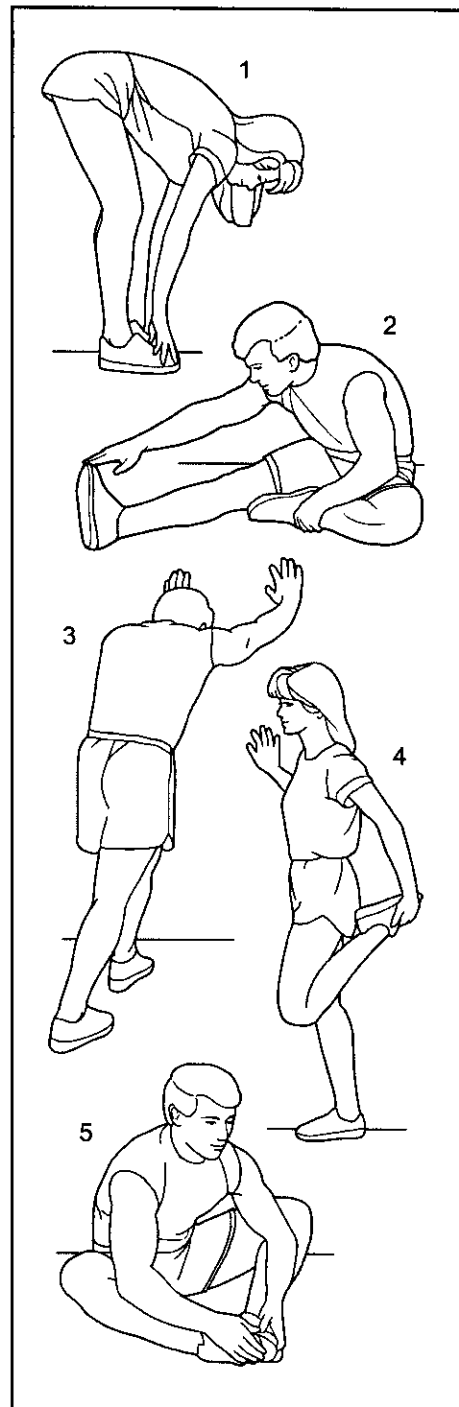

PART LIST—Model No. 831.294251

R1103A

To locate the parts listed below, refer to the EXPLODED DRAWING attached in the center of this manual.

Key No.	Qty.	Description	Key No.	Qty.	Description
1	2	Foot Rail Cover	50	1	Filter Wire
2	1	Left Foot Rail	51	1	Right Front Endcap
3	1	Left Front Endcap	52	1	Walking Belt
4	2	Belt Guide	53	1	Walking Platform
5	4	Belt Guide Screw	54	1	Frame
6	56	3/4" Screw	55	2	Platform Nut
7	1	Console Frame	56	1	Right Foot Rail
8	4	Cage Nut	57	1	Rear Roller
9	1	Incline Wire	58	1	Right Rear Foot
10	1	Warning Decal	59	1	Allen Wrench
11	2	Rear Platform Bolt	60	2	Rear Roller Adj. Bolt
12	1	Latch Cover	61	2	Rear Roller Washer
13	1	Pulse Bar Plate (Left)	62	1	Right Rear Endcap
14	1	Pulse Bar Plate (Right)	63	1	Photo Switch
15	2	Isolator	64	1	Left Rear Endcap
16	4	Platform Screw	65	2	Small Endcap Screw
17	2	Platform Pivot Bolt	66	1	Incline Motor
18	1	Magnet	67	2	Round Base Pad
19	2	Caution Decal	68	4	Pulse Bar Screw
20	1	Motor Pivot Bolt	69	2	Isolator Plate
21	7	Wheel Nut	70	1	Right Cup Holder (Bottom)
22	2	Frame Spacer	71	4	1/4" x 1" Bolt
23	1	Reed Switch Clip	72	1	Right Cup Holder (Top)
24	1	Reed Switch	73	1	Left Cup Holder (Bottom)
25	1	Reed Switch Screw	74*	1	Latch Assembly
26	1	Lift Frame	75	1	Latch Housing
27	1	Motor Tension Nut	76	1	Left Cup Holder (Top)
28	1	Motor	77	1	iFIT.com Wire
29	1	Pulley/Flywheel/Fan	78	1	Jack
30	1	Motor Belt	79	1	Book Holder
31*	1	Motor Assembly	80	4	Fan Housing Screw
32	1	Motor Tension Bolt	81	4	Isolator Plate Screw
33	5	Motor Tension Washer/ Lift Pivot Washer	82	2	Spring Bolt
34	1	Motor Star Washer	83	1	Wire Harness
35	2	Motor Bracket Bolt	84	2	Platform Spring
36	7	Small Screw	85	1	Console Base
37	1	Ground Wire	86	4	Fan Screw
38	1	Transformer	87	1	Fan
39	1	Hood	88	1	Console
40	1	Controller	89	1	Fan Housing
41	1	Power Cord	90	2	Isolator Screw
42	1	iFIT.com Wire Nut	91	1	Key/Clip
43	1	iFIT.com Wire	92	4	1/4" Star Washer
44	1	Power Cord Grommet	93	2	Isolator Cap
45	2	Static Decal	94	1	Access Door
46	1	Reset/Off Switch	95	1	Console Back
47	11	3/4" Tek Screw	96	1	Tie Holder
48	1	Belly Pan	97	1	Releasable Tie
49	1	Photo Switch Wire	98	8	Plastic Tie
			99	2	Base Endcap

Key No.	Qty.	Description	Key No.	Qty.	Description
100	4	Base Pad	125	1	Left Handgrip Bottom
101	2	Clevis Pin	126	1	Right Handgrip Top
102	3	Hairpin Cotter	127	1	Right Handgrip Bottom
103	2	Rear Roller Star Washer	128	2	Extension Leg
104	1	Decal Plate	129	1	Incline Stop Bracket
105	1	Outlet Plate	130	4	U-Nut
106	2	Wheel Housing	131	1	Left Rear Endcap
107	2	Wheel Bolt	132	1	Power Bracket Screw
108	2	Wheel	133	1	Photo Switch Washer
109	1	Upright	134	1	Photo Switch Nut
110	1	Pulse Bar	135	1	Lift Motor Pin
111	1	Incline Motor Bolt	136	4	Front Endcap Screw
112	2	4" Bolt	#	1	6" Blue Wire, 2 F
113	1	Cap Decal	#	1	4" Blue Wire, 2 F
114	1	1/2" Ground Screw	#	1	4" Blue Wire, M/F
115	1	5/16" Allen Wrench	#	1	4" Black Wire, M/F
116	1	iFIT.com Cable	#	1	4" Red Wire, M/F
117	1	Motor Bracket	#	1	12" Green Wire, F/Ring
118	2	Front Endcap Washer	#	1	8" Green Wire, 2 Ring
119	1	Front Roller Adj. Bolt	#	1	User's Manual
120	1	Front Roller/Pulley			
121	1	Optic Disk			
122	4	5/16" x 1" Bolt			
123	2	Handrail			
124	1	Left Handgrip Top			

*Includes all parts shown in the box

These parts are not illustrated

If a part is missing, call toll-free 1-800-999-3756.

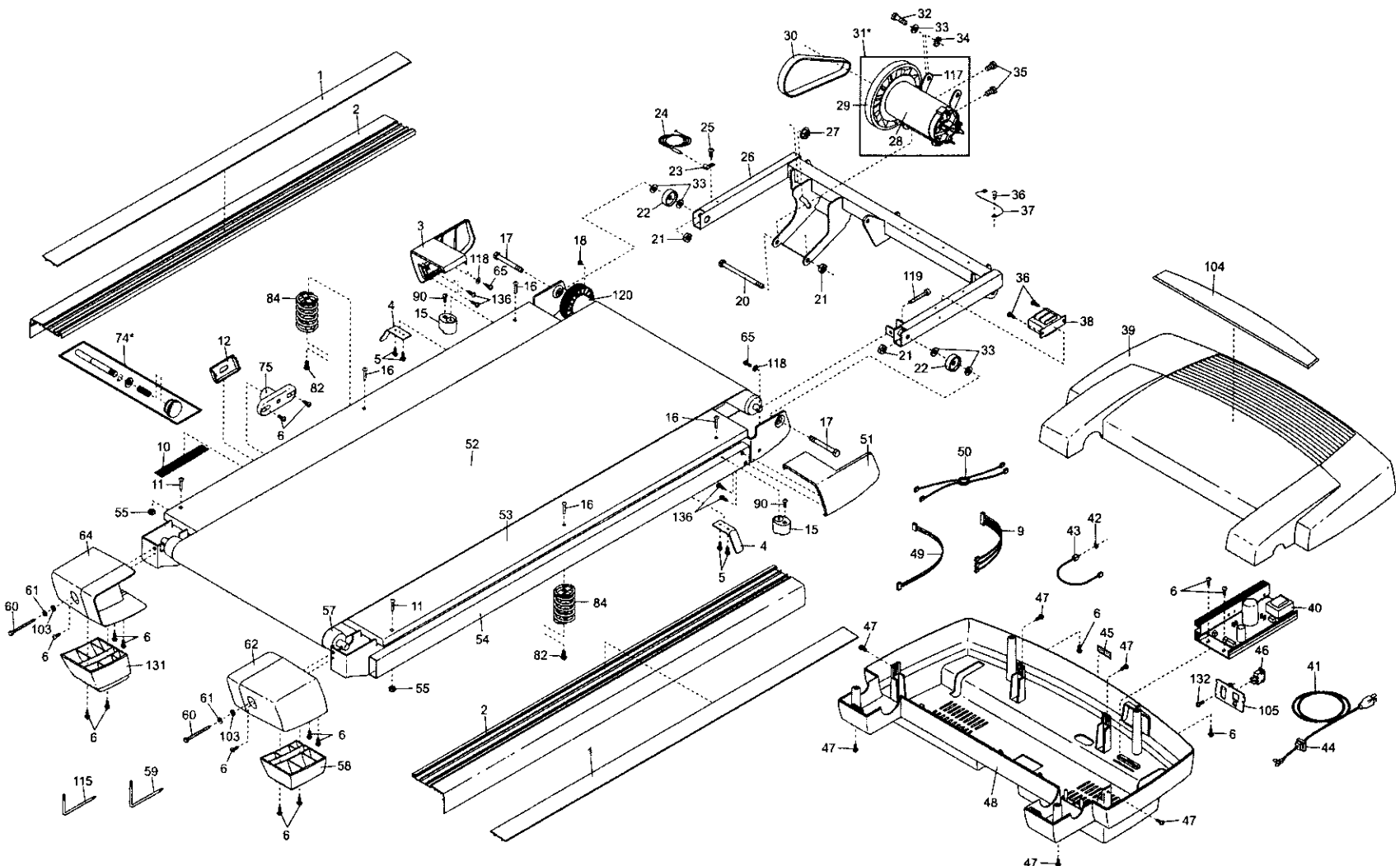

EXPLODED DRAWING—Model No. 831.294251

R1103A

EXPLODED DRAWING—Model No. 831.294251

R1103A

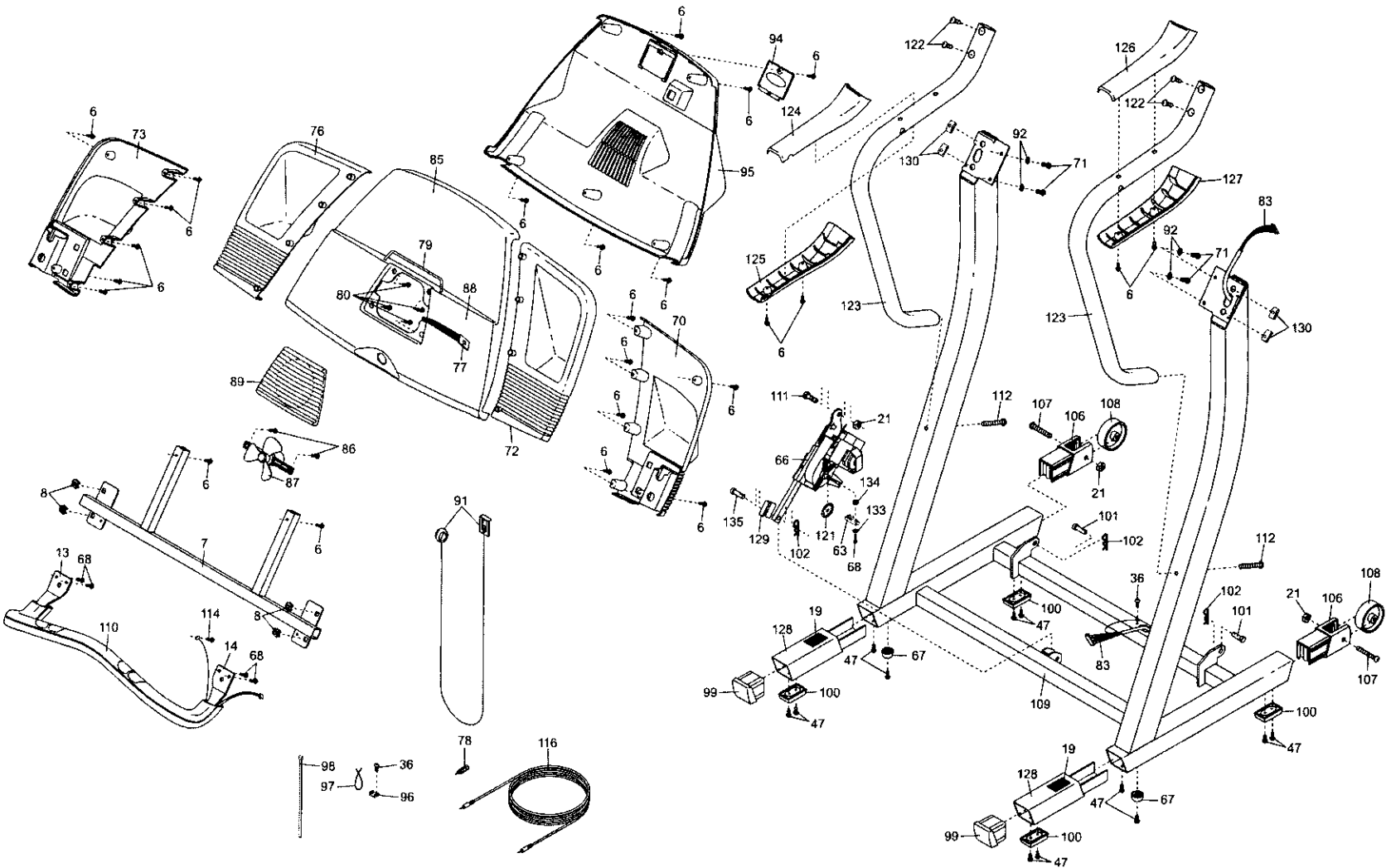

Get it fixed, at your home or ours!

Your Home

For repair – **in your home** – of **all** major brand appliances, lawn and garden equipment, or heating and cooling systems, **no matter who made it, no matter who sold it!**

For the replacement parts, accessories, and user's manuals that you need to do-it-yourself.

For Sears professional installation of home appliances and items like garage door openers and water heaters.

1-800-4-MY-HOME®

(1-800-469-4663)

www.sears.com

Anytime, day or night

(U.S.A. and Canada)

www.sears.ca

Our Home

For repair of carry-in products like vacuums, lawn equipment, and electronics, call or go on-line for the location of your nearest **Sears Parts and Repair Center.**

1-800-488-1222 Anytime, day or night (U.S.A. only)

www.sears.com

To purchase a protection agreement (U.S.A.) or maintenance agreement (Canada) on a product serviced by Sears:

1-800-827-6655 (U.S.A.)

1-800-361-6665 (Canada)

Para pedir servicio de reparación a domicilio, y para ordenar piezas:

1-888-SU-HOGARSM (1-888-784-6427)

SEARS

® Registered Trademark / ™ Trademark / SM Service Mark of Sears, Roebuck and Co.
© Marca Registrada / ™ Marca de Fábrica / SM Marca de Servicio de Sears, Roebuck and Co.

FULL 90 DAY WARRANTY

For 90 days from the date of purchase, if failure occurs due to defect in material or workmanship in this Sears Treadmill Exerciser, contact the nearest Sears Service Center throughout the United States and Sears will repair or replace the Treadmill Exerciser, free of charge.

This warranty does not apply when the Treadmill Exerciser is used commercially or for rental purposes.

This warranty gives you specific legal rights, and you may also have other rights which vary from state to state.

Sears, Roebuck and Co., Dept. 817WA, Hoffman Estates, IL 60179