

Operator's manual Rider 155

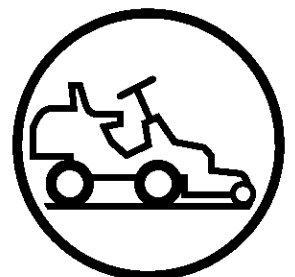

**Please read these instructions carefully and make sure
you understand them before using the machine.**

English

CONTENTS

Operator's Manual for Rider 155

Safety rules for USA	2	Adjusting the brake	25
Introduction	4	Adjusting the throttle wire	26
Driving and transport on public roads	4	Service of air filter	27
Towing	4	Battery	28
Intended use	4	Ignition System	28
Serial number	5	Inspection of the safety system	29
Explanation of symbols	6	Main fuse	30
Placards	7	Checking the tyre pressure	30
Safety instructions	8	Checking the engine's cooling air intake	30
General Use	8	Fitting the cutting unit	31
Driving on Slopes	10	Removing the cutting unit	32
Children	11	Checking and adjustment of cutting unit's ground pressure	33
Maintenance	11	Checking the parallelism of the cutting unit ...	34
Transport	12	Adjusting the parallelism of the cutting unit ...	34
Presentation	14	Replacing the cutting unit belt	35
Location of the controls	14	Service position for cutting unit	36
Throttle/Choke lever	15	Checking the blades	39
Speed limiter	15	Replacing the break-pin	40
Parking brake	15	Removal of BioClip plug	40
Cutting unit	16	Lubrication	41
Lift lever for cutting unit	16	Checking the engine's oil level	41
Lever for adjustment of cutting height	17	Changing the oil	41
Seat	17	Change of oil filter	42
Fuelling	17	Checking the transmission's oil level	42
Driving	18	Lubricating the belt adjuster	42
Before starting	18	General lubrication	42
Starting the engine	18	Trouble shooting schedule	43
Driving the machine	20	Storage	44
Cutting tips	21	Winter storage	44
Stopping the engine	22	Cover	44
Release lever	22	Service	44
Maintenance	23	Technical data	45
Maintenance schedule	23	Service journal	46
Removal of the machine hoods	24		
Checking and adjusting the steering wires	25		

IMPORTANT INFORMATION

Read carefully through the Operator's manual so that you know how to use and maintain the Rider before you use it.

For service measures other than those described in this manual, please contact an authorised dealer that provides parts and service.



1. Safety rules for USA



These instructions are for your safety. Read them carefully.

Safe operation practices for ride-on mowers

IMPORTANT!

This cutting machine is capable of amputating hands and feet and throwing objects. Failure to observe the following safety instructions could result in serious injury or death.

I. General operation

1. Read, understand and follow all instructions in the manual and on the machine before starting.
2. Only allow responsible adults, who are familiar with the instructions, to operate the machine.
3. Clear the area of objects such as rocks, toys, wire, etc., which could be picked up and thrown by the blade.
4. Be sure the area is clear of other people before mowing. Stop the machine if anyone enters the area.
5. Never carry passengers.
6. Do not mow in reverse unless absolutely necessary. Always look down and behind before and while backing.
7. Be aware of the mower discharge direction and do not point it at anyone. Do not operate the mower without either the entire grass catcher or the guard in place.
8. Slow down before turning.
9. Never leave a running machine unattended. Always turn off blades, set parking brake, stop engine and remove keys before dismounting.
10. Turn off blades when not mowing.
11. Stop engine before removing grass catcher or unclogging chute.
12. Mow only in daylight or good artificial light.
13. Do not operate the machine while under the influence of alcohol or drugs.
14. Watch for traffic when operating near or crossing roadways.
15. Use extra care when loading or unloading the machine into a trailer or truck.

II. Slope operation

Slopes are a major factor related to loss-of-control and tip-over accidents, which can result in severe injury or death. *All slopes require extra caution. If you cannot back up the slope or if you feel uneasy on it, do not mow it.*

DO

Mow up and down slopes, not across. Remove obstacles such as rocks, tree limbs, etc. Watch for holes, ruts or bumps. Uneven terrain could overturn the machine. *Tall grass can hide obstacles.*

Use slow speed. Choose a low gear so that you will not have to stop or shift while on the slope. Follow the manufacturer's recommendations for wheel weights or counterweights to improve stability. Use extra care with grass catchers or other attachments. These can change the stability of the machine. Keep all movement on the slopes *slow* and *gradual*. Do not make sudden changes in speed or direction. Avoid starting or stopping on a slope. If tires lose traction, disengage the blades and proceed slowly *straight* down the slope.

DO NOT

Do not turn on slopes unless necessary and then, turn slowly and gradually downhill, if possible.
Do not mow near drop-offs, ditches or embankments. The mower could suddenly turn over if a wheel is over the edge of a cliff or ditch, or if an edge caves in.
Do not mow on wet grass. Reduced traction could cause sliding.
Do not try to stabilize the machine by putting your foot on the ground.
Do not use grass catcher on steep slopes.

III. Children

Tragic accidents can occur if the operator is not alert to the presence of children. Children are often attracted to the machine and the mowing activity. *Never* assume that children will remain where you last saw them.

1. Keep children out of the mowing area and under the watchful care of another responsible adult.
2. Be alert and turn machine off if children enter the area.
3. Before and when backing, look behind and *down* for small children.
4. Never carry children. They may fall off and be seriously injured or interfere with safe machine operation.
5. Never allow children to operate the machine.
6. Use extra care when approaching blind corners, shrubs, trees or other objects that may obscure vision.



1. Safety rules for USA



IV. Service

1. Use extra care in handling gasoline and other fuels. They are flammable and vapours are explosive.
 - a) Use only an approved container.
 - b) Never remove gas cap or add fuel with the engine running. Allow engine to cool before refuelling. Do not smoke.
 - c) Never refuel the machine indoors.
 - d) Never store the machine or fuel container inside where there is an open flame, such as in a water heater.
2. Never run a machine inside a closed area.
3. Keep nuts and bolts, especially blade attachment bolts, tight and keep equipment in good condition.
4. Never tamper with safety devices. Check their proper operation regularly.
5. Keep machine free of grass, leaves or other debris build-up. Clean up oil or fuel spillage. Allow machine to cool before storing.
6. Stop and inspect the equipment if you strike an object. Repair, if necessary, before restarting.
7. Never make adjustments or repairs with the engine running.
8. Grass catcher components are subject to wear, damage and deterioration, which could expose moving parts or allow objects to be thrown. Frequently check components and replace with manufacturer's recommended parts, when necessary.
9. Mower blades are sharp and can cut. Wrap the blade(s) or wear gloves and use extra caution when servicing them.
10. Check brake operation frequently. Adjust and service as required.



Danger, keep hands and feet away

Travel and transport on public roads

Check the relevant road traffic regulations before driving the machine on a public road. If transporting the machine on another vehicle always use approved securing devices and make sure that the machine is securely held.

Towing

If your machine has a hydrostatic transmission you should only tow it very short distances at low speed if absolutely necessary, otherwise the transmission may be damaged.

Intended use

This machine is designed solely for cutting grass on conventional lawns and other cleared and leveled ground without obstacles, as rocks, stumps etc., and, in conjunction with accessories supplied by the manufacturer even for other special tasks for which instructions are delivered with the accessory. Use in any other way is considered as contrary to the intended use. Compliance with and strict adherence to the conditions of operation, service and repair as specified by the manufacturer also constitute essential elements of the intended use.

This machine should be operated, serviced and repaired only by persons who are familiar with its particular characteristics and who are acquainted with the relevant safety procedures.

Accident prevention regulations, all other generally recognised regulations on safety and occupational medicine, and all road traffic regulations must be observed at all times.

Any arbitrary modifications carried out to this machine may relieve the manufacturer of liability for any resulting damage or injury.

Safe operation practices for Ride-On Mowers

Before starting cutting operations, train different driving operations on an open ground without people nearby until you feel familiar with handling the equipment. This is particularly important if you have no or little prior experience of driving a vehicle.

Data indicates that operators, age 60 years and above, are involved in a large percentage of riding mower-related injuries. These operators should evaluate their ability to operate the riding mower safely in order to protect themselves and others from serious injury.

Never carry children, even with the blades off. They may fall off and be seriously injured or interfere with safe machine operation.

INTRODUCTION

Dear customer

Thank you for choosing a Husqvarna Rider. Husqvarna Riders are built to a unique design with a frontmounted cutting unit and a patented rear-wheel steering system. Riders are designed for maximum efficiency even in small or confined areas. Collected controls and a hydrostatic transmission controlled by pedals also contribute to the machine's performance.

We hope you will find this operator's manual very useful. By following its instructions (on operation, service, maintenance, etc.) you will significantly extend the life of the machine and even its second-hand value.

When you sell your Rider, make sure you pass on the operator's manual to the new owner.

Travel and transport on public roads

Check the relevant road traffic regulations before driving the machine on a public road. If transporting the machine on another vehicle always use approved securing devices and make sure that the machine is securely held.

Towing

Your machine is equipped with a hydrostatic transmission and, if necessary, you should only tow the machine over short distances and at a low speed, otherwise there is a risk of damaging the transmission.

Intended use

This machine is designed solely for cutting grass on conventional lawns and other cleared and leveled ground without obstacles, as rocks, stumps etc., and, in conjunction with accessories supplied by the manufacturer even for other special tasks for which instructions are delivered with the accessory. Use in any other way is considered as contrary to the intended use. Compliance with and strict adherence to the conditions of operation, service and repair as specified by the manufacturer also constitute essential elements of the intended use.

This machine should be operated, serviced and repaired only by persons who are familiar with its particular characteristics and who are acquainted with the relevant safety procedures.

Accident prevention regulations, all other generally recognised regulations on safety and occupational medicine, and all road traffic regulations must be observed at all times.

Any arbitrary modifications carried out to this machine may relieve the manufacturer of liability for any resulting damage or injury

INTRODUCTION

Good service

Husqvarna products are sold all over the world and only through servicing dealers. This is to ensure that you, the customer, get the best support and service.

When you need spare parts or advice on service issues, warranty terms, etc., contact:

This Operator's Manual belongs to machine with serial number:	Engine	Transmission

Serial number

The serial number can be found on the printed plate attached to the front, left-hand side under the seat. Stated on the plate, from the top are:

- The machine's type designation.
- The manufacturer's type number.
- The machine's serial number.

State the type designation and serial number when ordering spare parts.

The engine identification numbers appear on a decal affixed to the engine shrouding. The text states:

- Model no.
- Spec no.
- Serial no.

Please state these when ordering spare parts. Include letter suffixes, if there are any.

The transmission's serial number is stated on the barcode decal located on the front of the housing on the left-hand drive axle:

- Type designation is stated above the barcode and starts with the letter "K".
- The serial number is stated above the barcode and has the prefix "s/n".
- The manufacturer's type number is stated under the barcode and has the prefix "p/n".

State the type designation and serial number when ordering spare parts.

EXPLANATION OF SYMBOLS

These symbols are on the machine and in the operator's manual.
Study them carefully so that you know what they mean.



Read the operator's manual

R

Reverse

N

Neutral



Fast



Slow



Engine off

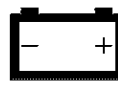

Battery



Choke



Fuel



Oil level



Cutting height



Backwards



Forwards



Ignition

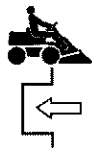

Hydrostatic free wheel



Use hearing protection



Parking brake



Brake



Warning



Never use the machine if persons, especially children, or animals, are in the vicinity.



Never carry passengers on the machine or equipment.



Warning!
Risk that the machine can tip over



Never drive across a slope



Keep hands and feet away from moving parts.



Drive very slowly without the cutting unit.

STARTING INSTRUCTION

- READ OPERATOR'S MANUAL.
- CHECK ENGINE OIL LEVEL.
- ENGAGE PARKING BRAKE AND LIFT CUTTING DECK IN TRANSPORT POSITION.
- IF ENGINE IS COLD USE CHOKE.
- START THE ENGINE.
- RELEASE PARKING BRAKE BEFORE DRIVING.

INSTRUCTIONS DE DEMARRAGE

- LIRE LE GUIDE DE CONDUITE.
- VÉRIFIEZ LE NIVEAU D'HUILE MOTEUR.
- SERREZ LE FREIN DE PARKING ET METTRE LE CARTER DE COUPE EN POSITION HAUT.
- SI LE MOTEUR EST FROID, UTILISEZ LE STARTER.
- ACTIONNEZ LE DÉMARREUR.
- DESSERREZ LE FREIN DE PARKING



Speed limiter pedal forwards

Neutral

Speed limiter pedal reverse



Switch off the engine and take off the ignition cable before repairs or maintenance

EXPLANATION OF SYMBOLS

Placards

KOHLER engines
 KOHLER CO. KOHLER, WISCONSIN USA
 REFER TO OWNER'S MANUAL FOR SAFETY, MAINTENANCE SPECS AND ADJUSTMENTS. FOR SALES AND SERVICE IN US/CANADA, CALL:
 1-800-544-2444

MODEL NO.
 SPEC NO.
 SERIAL NO.

KOHLER COMMAND
15.5 HP

- Overhead Valve
- Cast Iron Cylinder Liner
- Automotive Type Oil Filter
- Hydraulic Valve Lifters
- Full Pressure Lubrication

Husqvarna

NOTE!
 REMOVE DEBRIS FROM THE FOAM COVER DAILY OR BEFORE STARTING THE ENGINE TO PREVENT ENGINE OVERHEATING.

WARNING



Hot parts can cause severe burns.
 Do not touch.
 See Owner's Manual

Explosive fuel can cause fires and severe burns.
 Stop Engine before filling fuel tank.
 See Owner's Manual.

ENGINE MAINTENANCE INFORMATION

AIR CLEANER
 PRECLEANER-CHECK DAILY
 PAPER ELEMENT-INSPECT WEEKLY. REPLACE OR CLEAN. TAP LIGHTLY TO REMOVE DIRT. INSPECT MORE OFTEN IN DUSTY CONDITIONS.

DIL-OIL FILTER
 CHECK ENGINE OIL LEVEL DAILY BY SETTING DIPSTICK ONTO TUBE.
 OIL CHANGE - 100 HOURS/ONCE A SEASON.
 SUMMER-USE SAE 10W30
 WINTER-USE SAE 5W30
 OIL FILTER CHANGE-200 HOURS/ EVERY OTHER OIL CHANGE.

FOR PERSONAL SAFETY WARNINGS AND DETAILED MAINTENANCE INFORMATION, SEE THE ENGINE OWNER'S MANUAL. SALES SERVICE INFORMATION US CANADA CALL 1-800-544-2444
12 113 04 (5-85)

WARNING



Carbon Monoxide can cause severe nausea, fainting, or death. Do not use indoors without Kohler Emission System and adequate ventilation.

WARNING



Do not operate engine with cover removed.
 See Owner's Manual.

CAUTION



Electrical Shock can cause injury.
 Do not touch wires while engine is running.

WARNING



Accidental Starts can cause severe injury or death.
 Disconnect and ground spark plug lead(s) before servicing.

AVOID SERIOUS INJURY OR DEATH.

- GO UP AND DOWN SLOPES, NOT ACROSS.
- AVOID SUDDEN TURNS.
- IF MACHINE STOPS GOING UPHILL, STOP BLADE AND BACK DOWN SLOWLY.
- DO NOT MOW WHEN CHILDREN OR OTHERS ARE AROUND.
- NEVER CARRY CHILDREN EVEN WHEN BLADES OFF.
- LOOK DOWN AND BEHIND BEFORE AND WHILE BACKING.
- KEEP SAFETY DEVICES (GUARDS, SHIELDS, AND SWITCHES) IN PLACE AND WORKING.
- REMOVE OBJECTS THAT COULD BE THROWN BY THE BLADE.

READ OPERATOR'S MANUAL.

DANGER DE BLESSURES GRAVES OU MORTELLES.

- NE JAMAIS TRAVERSER UNE PENTE. SE DÉPLACER DANS LA LIGNE DE LA PENTE.
- ÉVITER LES VIRAGES BRUSQUES.
- EN FAISANT DES MANÈVRES DE MONTÉE, ARRÊTER LES LAMES ET REVENIR EN ARRIÈRE LENTEMENT.
- NE PAS PORTER DE ENFANTS NI D'AUTRES PERSONNES.
- NE JAMAIS TRANSPORTER D'ENFANTS NI DES ANIMAUX AVEC LES LAMES ARRÊTÉES.
- REGARDER VERS LE BAS ET EN ARRIÈRE AVANT ET PENDANT LA MARCHÉ ARRÊTÉ.
- GARDER TOUS LES DISPOSITIFS DE SÉCURITÉ (PROTECTEURS, VOILES DE PROTECTION ET CONTACTEURS) EN PLACE ET À ASSURER DE LEUR BON FONCTIONNEMENT.
- METTRE DE CÔTÉ TOUT OBJET POSSANT ÊTRE PROJÉTÉ PAR LES LAMES.

LIRE LE MANUEL DU PROPRIÉTAIRE. 10044009

8009-442

SAFETY INSTRUCTIONS

Safety instructions

These instructions are for your safety. Read them carefully.



WARNING!

The inserted symbol means that important safety instructions need to be observed. It applies to your safety.

General use

- Read all the instructions in this operator's manual and on the machine before you start it. Ensure you understand them and then observe them.
- Learn how to use the machine and its controls safely and learn to how to stop quickly. Also learn to recognize the safety decals.
- Only allow the machine to be used by adults who are familiar with its use.
- Make sure nobody else is in the vicinity of the machine when you start the engine, engage the drive or drive off.
- Make sure animals and people maintain a safe distance from the machine.
- Stop the machine if any one enters the working area.
- Clear the area of objects such as stones, toys, wires, etc. that may become caught in the blades and be thrown out.
- Look out for the ejector and do not direct it towards anyone.
- Stop the engine and prevent the engine from being started until you have cleaned the cutting unit or outlet channel.
- Remember the operator is responsible for danger or accidents.
- Never carry passengers. The machine is only intended to be used by one person.
- Always look downwards and backwards before and while reversing. Keep watch for both large and small obstacles.
- Slow before cornering.
- Switch off the blades when you are not mowing.

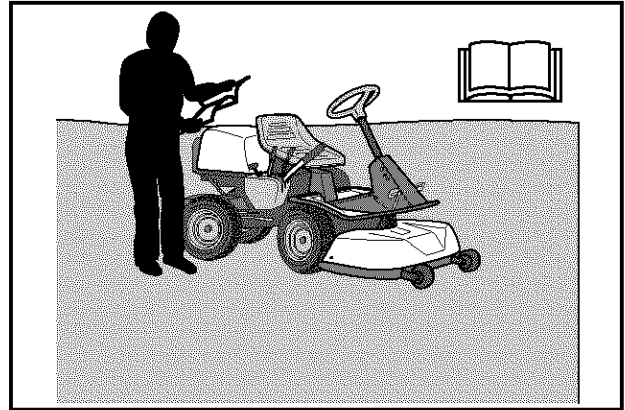

8010-047

Read the operator's manual before starting the machine.

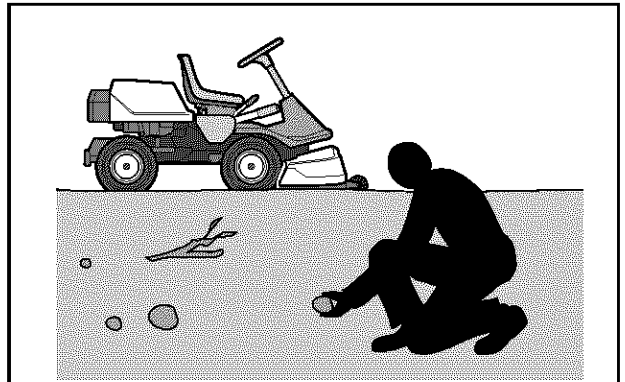

6003-002

Clear the area of objects before mowing.

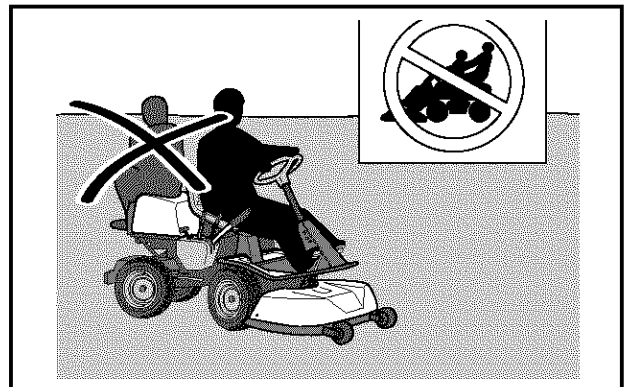

8010-052

Never carry passengers.



WARNING!

This machine can sever hands and feet as well as throw objects. Failure to observe the safety instructions can result in serious injuries.

SAFETY INSTRUCTIONS

- Take care when rounding a fixed object, so that the blades do not hit it. Never run the machine over foreign objects.
- Only use the machine in daylight or in other well-lit conditions. Keep the machine at a safe distance from holes or other irregularities in the ground. Pay attention to other possible risks.
- Never use the machine if you are tired, if you have consumed alcohol, or if you are taking other drugs or medication that can affect your vision, judgment or co-ordination.
- Keep an eye on the traffic when working close to a road or when crossing it.
- Never leave the machine unsupervised with the engine running. Always stop the blades, apply the parking brake, stop the engine and remove the keys before leaving the machine.
- Never allow children or other persons not trained in the use of the machine to use or service it. Local laws may regulate the age of the user.

 **WARNING!**
Engine exhaust, some of its constituents and certain vehicle components contain or emit chemicals considered to cause cancer, birth defects or other reproductive impairment. The engine emits carbon monoxide, which is a colourless, poisonous gas. Do not use the machine in enclosed spaces.

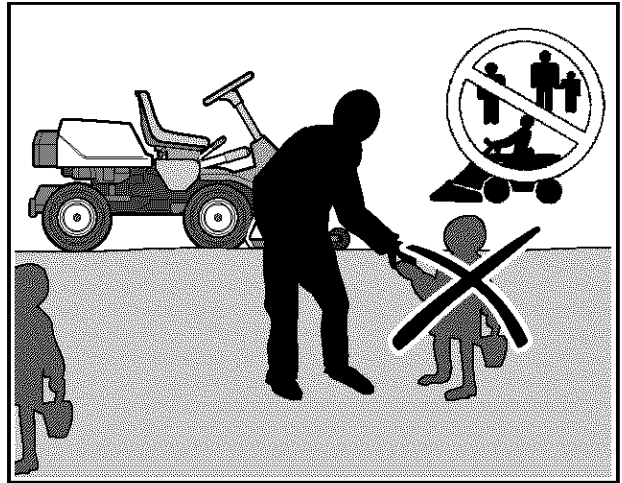

6003-006

Keep children away from the area to be mowed.



WARNING!

You must use approved personal protective equipment whenever you use the machine. Personal protective equipment cannot eliminate the risk of injury but it will reduce the degree of injury if an accident does happen. Ask your dealer for help in choosing the right equipment.

- Make sure that you have first aid equipment close at hand when using the machine.
- Never use the machine when barefoot. Always wear protective shoes or protective boots, preferably with steel toes.
- Wear approved protective glasses or full-face visor during assembly and when operating.
- Never wear loose fitting clothes that can catch in moving parts.
- Use ear protectors to eliminate the risk for impairment of hearing.

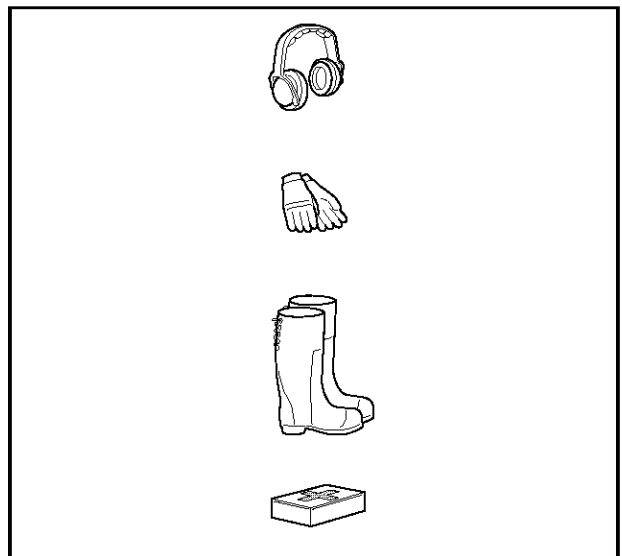

8011-292

Personal protective equipment.

SAFETY INSTRUCTIONS

Driving on slopes

Driving on slopes is one of the operations where the risk of the driver losing control of the machine or of it overturning is the greatest; this can result in serious injury or death. All slopes demand extra care. If you cannot reverse up a slope or if you feel unsure, do not mow it.

Proceed as follows:

- Remove obstacles such as stones, branches, etc.
- Mow upwards and downwards, not sideways.
- Do not use the machine on ground that slopes more than 15°.
- Avoid starting or stopping on a slope. If the tyres start to slip, stop the blades and drive slowly down the slope.
- Always drive smoothly and slowly on slopes.
- Do not make any sudden changes in speed or direction.
- Avoid unnecessary turns on slopes, if necessary, turn slowly and gradually downwards if possible.
- Watch out for and avoid driving over furrows, holes and bumps. It is easier for the machine to overturn on uneven ground. Tall grass can hide obstacles.
- Drive slowly. Do not turn the wheel sharply. The machine engine-brakes better in low gear.
- Take extra care if any attachments are fitted that can change the stability of the machine.
- Do not mow too close to edges, ditches or banks. The machine can suddenly overturn if one wheel comes over the edge of a steep slope or a ditch, or if an edge gives way.
- Do not mow wet grass. It is slippery, and tyres can lose their grip so that the machine skids.
- Do not try to stabilize the machine by putting your foot on the ground.
- When cleaning the chassis the machine must never be driven close to an edge or ditch.
- Follow the manufacturer's recommendations regarding wheel weights or counterbalance weights to increase stability.

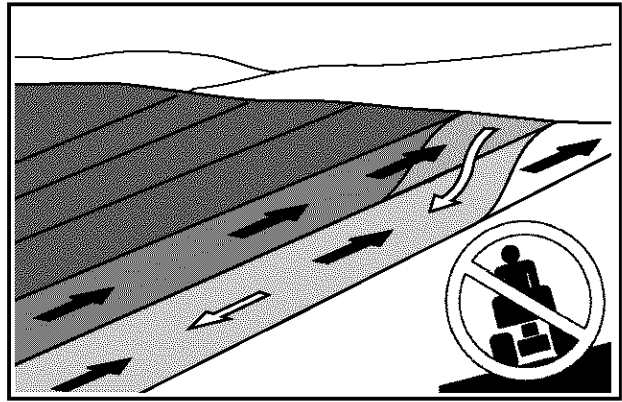

Mow upwards and downwards on slopes, not sideways.

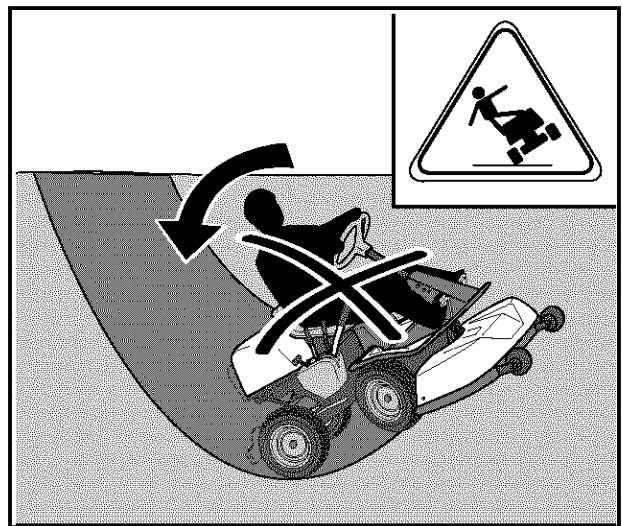

Be especially careful when driving on slopes.

SAFETY INSTRUCTIONS

Children

- Serious accidents may occur if you fail to be on your guard for children in the vicinity of the machine. Children are often attracted to the machine and mowing. Never assume that children will remain where you last saw them.
- Keep children away from the area to be mowed and under close supervision by another adult.
- Keep an eye out and shut off the machine if children enter the work area.
- Before and during reversing procedures, look behind you and down for small children.
- Never allow children to ride along. They can fall off and seriously injure themselves or be in the way for safe manoeuvring of the machine.
- Never allow children to operate the machine.
- Be particularly careful near corners, bushes, trees or other objects that block your view.

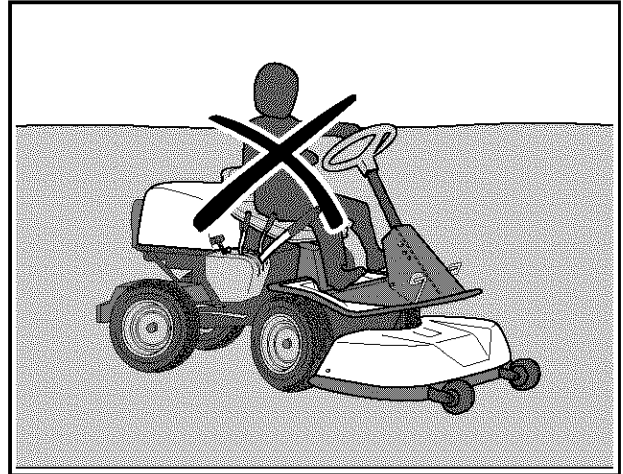

8010-057

Never allow children to operate the machine.

Maintenance

- Stop the engine. Prevent starting by removing the ignition cable from the spark plug or remove the ignition key before making any adjustments or carrying out maintenance.
- Never fill the fuel tank indoors.
- Petrol and petrol fumes are poisonous and extremely flammable. Be especially careful when handling petrol, as carelessness can result in personal injury or fire.
- Only store fuel in containers approved for the purpose.
- Never remove the fuel cap and fill the petrol tank while the engine is running.
- Allow the engine to cool before refuelling. Do not smoke. Do not fill petrol in the vicinity of sparks or naked flames.
- Electrical shock can cause injury. Do not touch wires while engine is running or cranked around. Do not test ignition system using your finger.
- Pay attention to the risk of environmental influence when handling oil, oil filter, fuel and battery. Observe the local waste regulations.



8010-058

Never fill the fuel tank indoors.

SAFETY INSTRUCTIONS

- If leaks arise in the fuel system, the engine must not be started until the problem has been resolved.
- Store the machine and fuel in such a way that there is no risk that leaking fuel or fumes can cause any damage.
- Check the fuel level before each use and leave space for the fuel to expand, because the heat from the engine and the sun may otherwise cause the fuel to expand and overflow.
- Avoid overfilling. If you spill petrol on the machine, wipe up the spill and wait until it has evaporated before starting the engine. If you spill petrol on your clothing, change your clothing.
- Allow the machine to cool before performing any actions in the engine compartment.
- Be especially careful when handling battery acid. Acid on the skin can cause serious corrosive injuries. In the event of spillage on the skin wash immediately with water.
- Acid in the eyes can cause blindness, contact a doctor immediately.
- Take care with battery maintenance. Explosive gases form in the battery. Never perform maintenance on the battery while smoking or in the vicinity of open flames or sparks. This can cause the battery to explode and cause serious injuries.
- Make sure all nuts and bolts are tightened correctly and that the equipment is in good condition.
- Do not modify safety equipment. Check regularly to be sure it works properly. The machine must not be driven if protective plates, protective covers, safety switches or other protective devices are not fitted or are defective.
- Do not change the setting of governors and avoid running the engine at excessively high revs. If you run too fast, you risk damaging the machine components.
- Observe the risk of injury caused by moving or hot parts if the engine is started with the engine cover opened or the protective covers removed.



WARNING!
The engine and the exhaust system become very hot during operation.
Risk of burn injuries if touched.



WARNING!
The battery contains lead and lead pollutants, chemicals that are considered to cause cancer, birth defects or other reproductive impairment. Wash your hands after touching the battery.

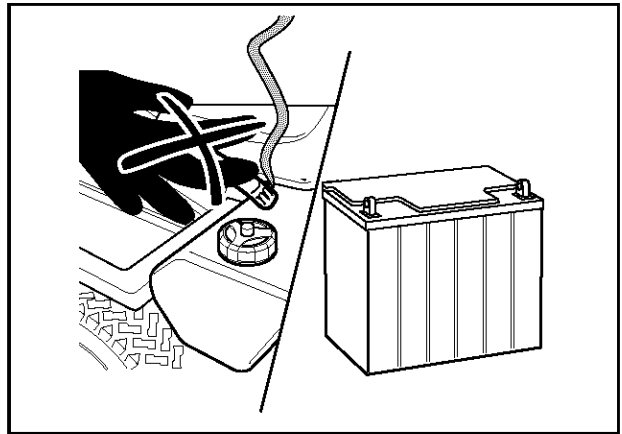

Do not smoke when carrying out maintenance.

8009-441

SAFETY INSTRUCTIONS

- Never use the machine indoors or in spaces lacking proper ventilation. Exhaust fumes contain carbon monoxide, an odourless, poisonous and highly dangerous gas.
- Stop and inspect the equipment if you run over or into anything. If necessary, make repairs before starting.
- Never make adjustments with the engine running.
- The machine is tested and approved only with the equipment originally provided or recommended by the manufacturer.
- The blades are sharp and can cause cuts. Wrap the blades or wear protective gloves when handling them.
- Check regularly that the parking brake works. Adjust and maintain as required.
- The mulching function should only be used where better quality mowing is required and in known areas.
- Reduce the risk of fire by removing grass, leaves and other debris that may have fastened on the machine. Allow the machine to cool before putting it in storage.

Transport

- The machine is heavy and can cause serious crush injuries. Be especially careful when it is loaded in or out of a car or on and off of a trailer.
- Use an approved trailer to transport the machine. Activate the parking brake and secure the machine using approved fasteners, such as tension belts, chains or ropes when transporting.
- Check and observe local road traffic regulations before transporting or driving the machine on roads.

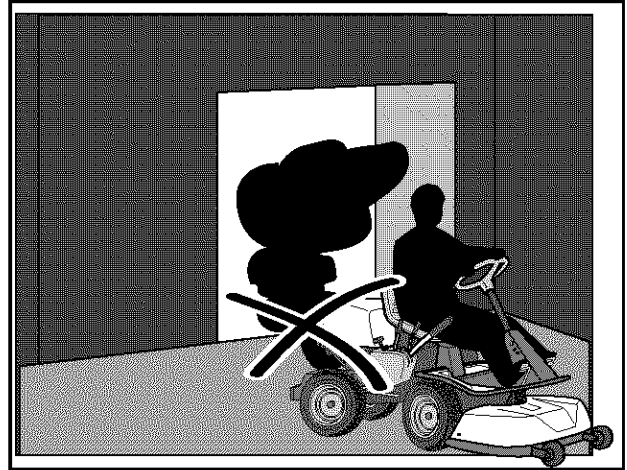

Never run the machine in an enclosed area.

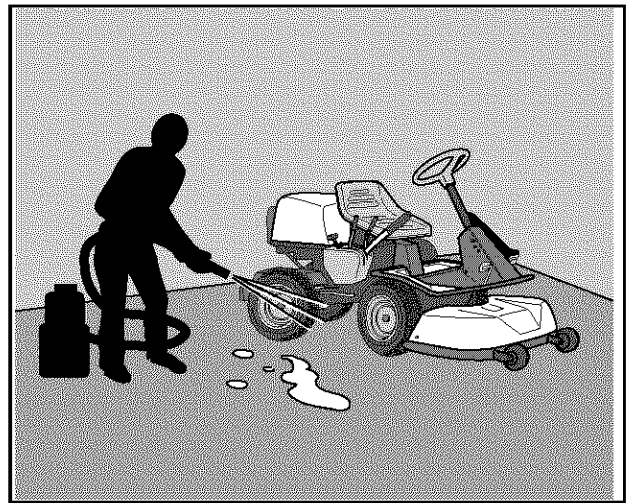

Regularly clean grass, leaves and other debris from the machine.

IMPORTANT INFORMATION

The parking brake is not sufficient to lock the machine during transport. Ensure you secure the machine firmly to the transporting vehicle. Reverse the machine on to the transporting vehicle to prevent it from overturning.

PRESENTATION

Presentation

Congratulations on your choice of a top quality product which you will enjoy for many years.

These instructions describe the Rider 155. This rider mower is equipped with a 15.5 horsepower Kohler engine.

The power transmission from the engine is handled by a hydrostatic gearbox, which allows variable variation of the speed by using the pedals.

There is one pedal for driving forwards and one pedal for reversing.

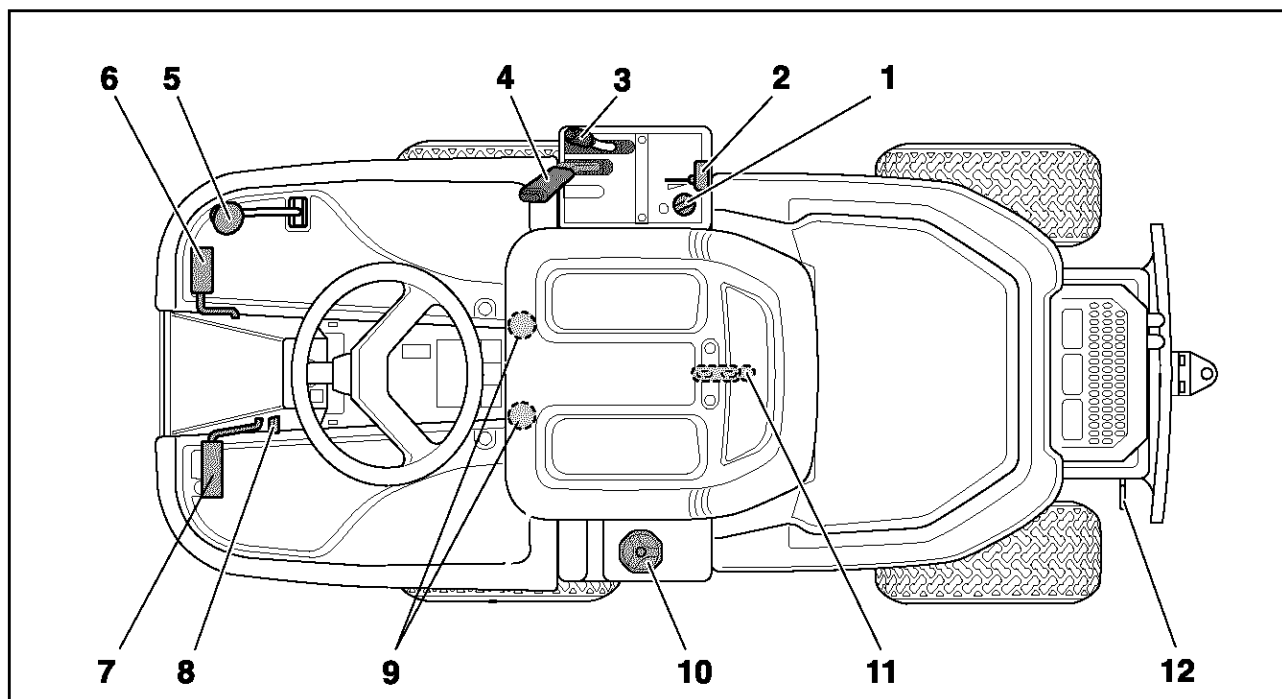
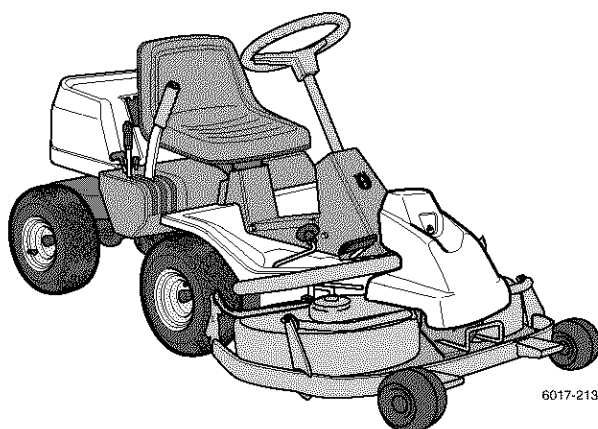

8009-114

Location of the controls

- | | |
|---------------------------------------|--------------------------------------|
| 1. Ignition lock | 7. Parking brake |
| 2. Throttle/Choke lever | 8. Lock button for parking brake |
| 3. Adjustment of cutting height | 9. Knobs for adjusting seat |
| 4. Lifting lever, cutting unit | 10. Fuel tank cap |
| 5. Speed limiter for reversing | 11. Main lock (under seat) |
| 6. Speed limiter for driving forwards | 12. Lever for disengagement of drive |

PRESENTATION

Throttle and Choke lever

The engine speed is adjusted with the throttle control, and thereby also the rotation speed of the blades.

The control is also used to activate the choke function. When the choke is used the engine receives a richer mixture of fuel and air, which simplifies cold start.

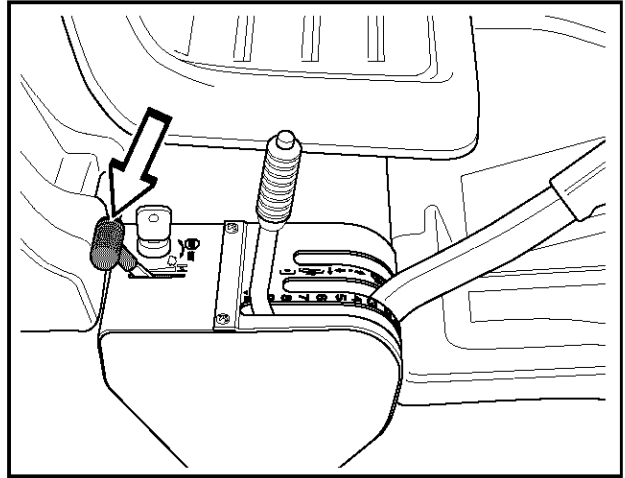

6004-004H

Speed limiter

The speed of the machine is steplessly regulated with two pedals. Pedal (1) is used to drive forwards and pedal (2) for reversing.

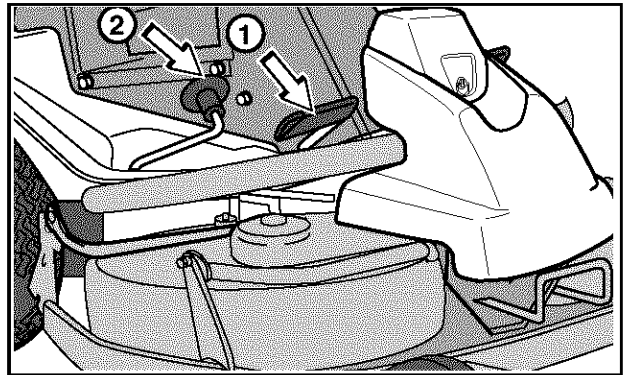
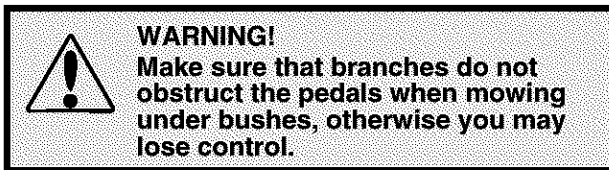

6017-214A

Parking brake

The parking brake is applied as follows:

1. Press down the brake pedal.
2. Press in the lock button on the steering column.
3. Release up the brake pedal while holding the button pressed.

The lock on the parking brake automatically disconnects when the brake pedal is pressed.

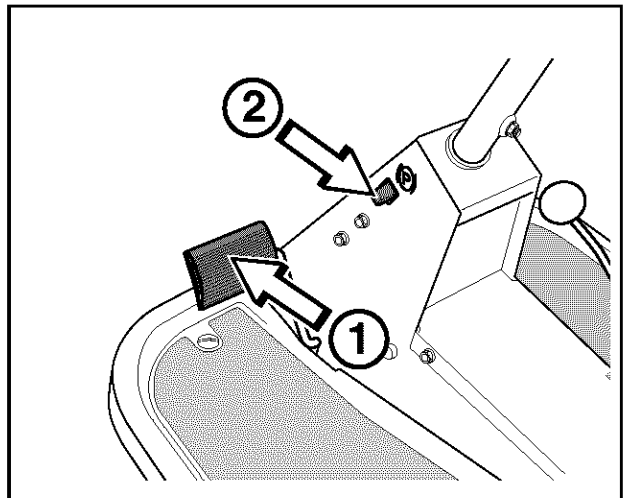

6017-011

PRESENTATION

Cutting unit

The Rider 155 is equipped with cutting unit.

- Combi - 1030 mm/41"

The combi deck functions as a mulching deck when a BioClip plug is mounted. Otherwise, the deck will function as a rear ejection deck.

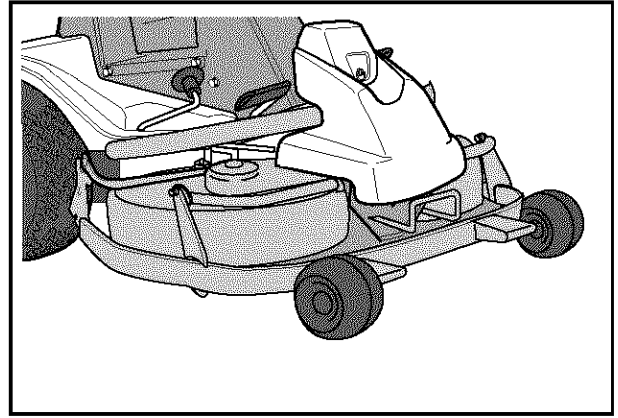

6017-214

Lift lever for cutting unit

The lift lever is used to set the cutting unit in transport or cutting position.

If the lever is pulled back the unit will lift up and the blades will automatically stop rotating (transport position).

If the lock button is pressed and the lever is moved forward the unit will be lowered and the blades will automatically start rotating (cutting position).

The lever can also be used to temporarily regulate the cutting height, e.g. for a small mound in the lawn.

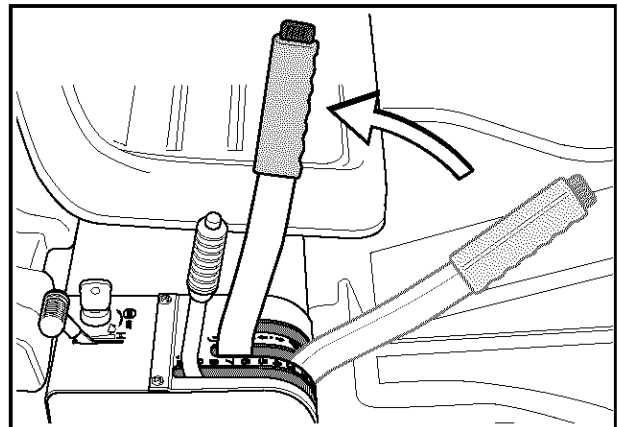

6004-011H

Lifting of the cutting unit (transport position)

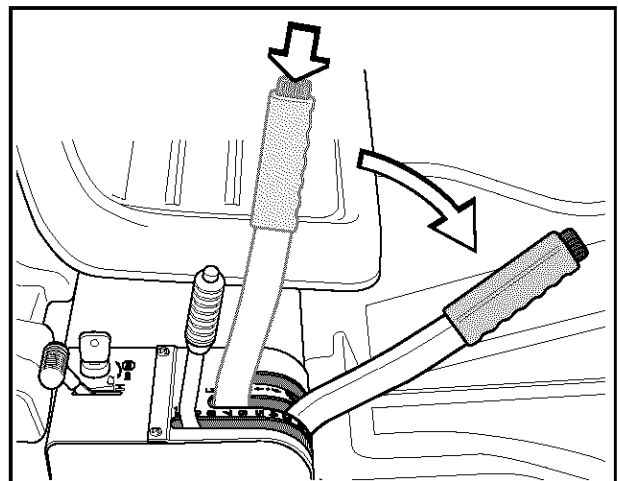

6004-012H

Lowering of the cutting unit (cutting position)

PRESENTATION

Lever for adjustment of cutting height

With this lever the cutting height can be adjusted to 9 different positions.

Combi 103 unit,

45-95 mm
(1 3/4" - 3 3/4")

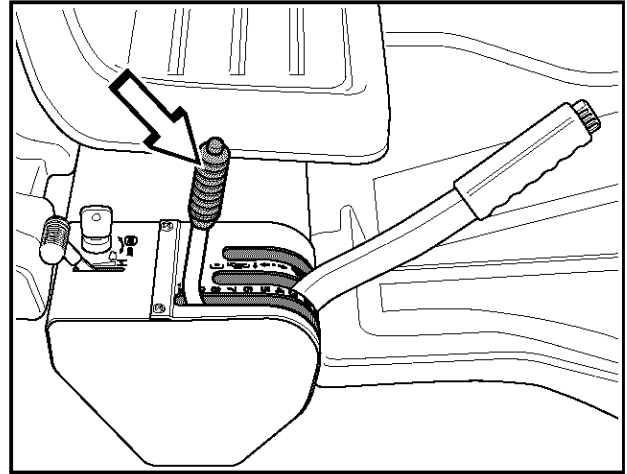

6004-013H

Seat

The seat has a jointed attachment on the front edge and can be tipped forward.

The seat can also be adjusted lengthways.

Release the knobs under the seat and adjust it forwards or backwards to the required position.

Lock the setting with the knobs.

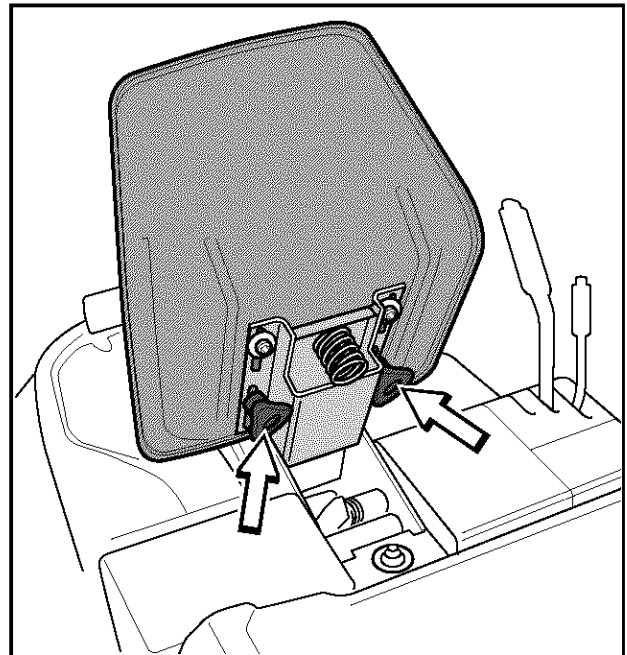

6004-014H

Fuelling

The engine should be run on 87 octane (or higher) unleaded petrol/gasoline (no added oil).

Gasohol or MTBE mix, see "Technical Data".

No other fuel is approved by Kohler Engines.

Do not fill the tank completely, leave an expansion area of at least 2.5 cm (1").

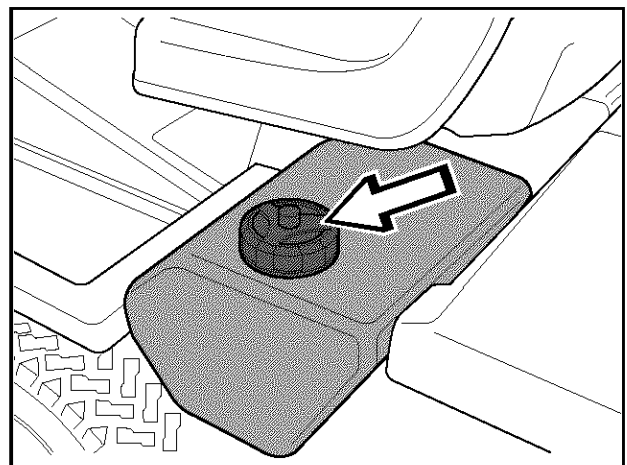

6004-015



WARNING!
Petrol/gasoline is highly flammable. Observe care and fill up with fuel outdoors (see safety instructions).

DRIVING

IMPORTANT INFORMATION

The air intake grille in the engine cover behind the driver's seat must not be blocked by, for example, clothing, leaves, grass or dirt.

Impaired cooling of the engine. Risk of major engine damage.

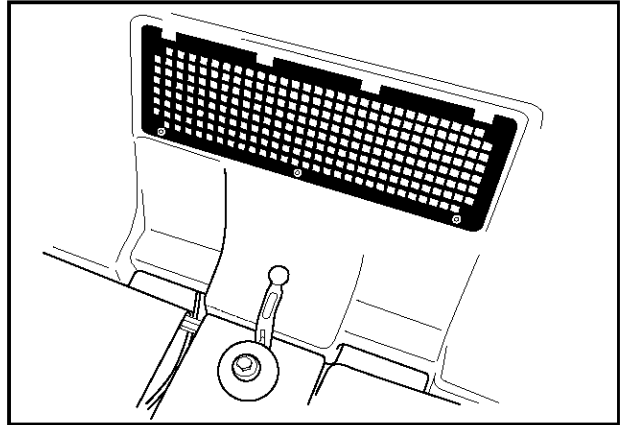

8009-431

Before starting

- Read the safety instructions and information on the location and function of the controls before starting.
- Conduct daily maintenance before starting (see "Maintenance Schedule").

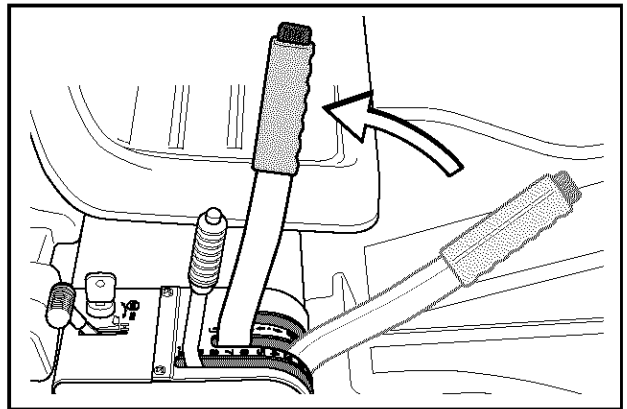

6007-001H

Starting the engine

1. Lift up the cutting unit by pulling the lever backwards to locked position (transport position).
2. Apply the parking brake. This is done as follows:
 - Press down the brake pedal (1).
 - Press in the lock button on the steering column (2).
 - Release the brake pedal while the button is held pressed.

The parking brake lock disconnects automatically when the brake pedal is pressed down.

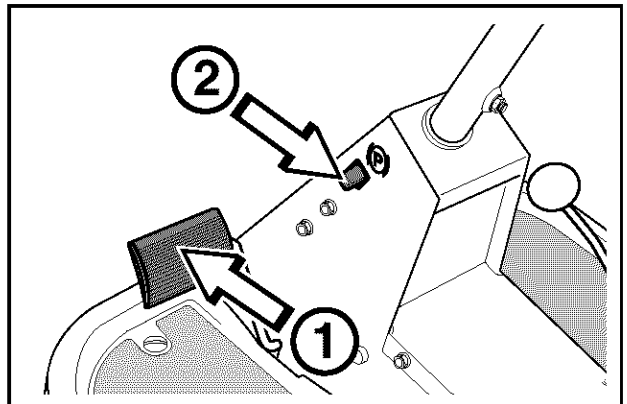

6017-011

Cold engine:

3. Push the throttle control to position 3 (choke position). In this position the engine receives a richer mixture so that the engine starts more easily.

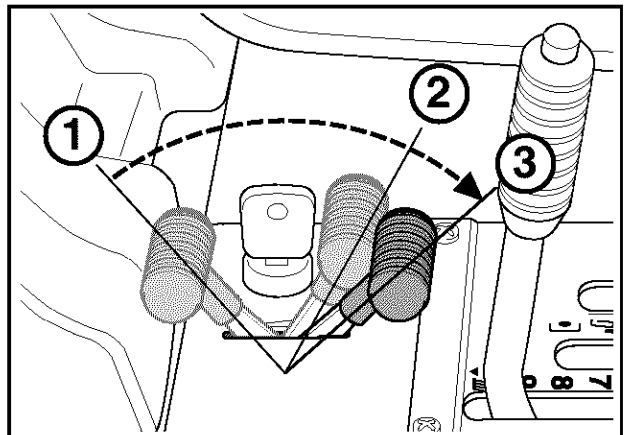

6007-004H

DRIVING

Warm engine:

4. Set the throttle control midway between position 1 and 2.

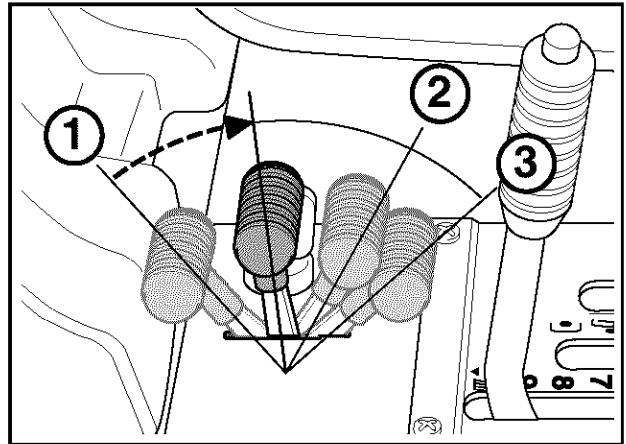

6007-005H

5. Turn the ignition key to start position.

IMPORTANT INFORMATION

Do not run the starter for more than about 10 seconds at a time. If the engine does not start, wait about 60 seconds before trying again.

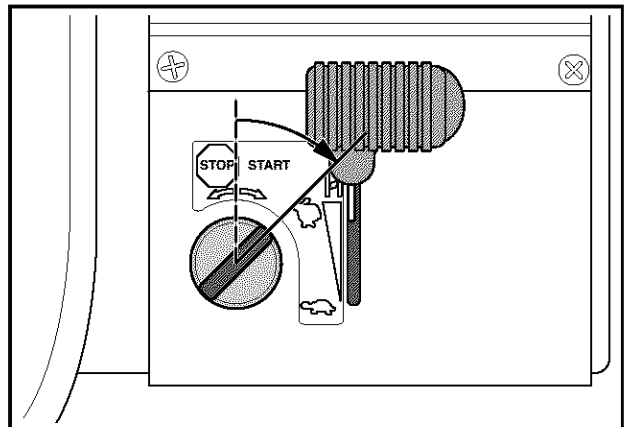

6007-006

6. When the engine has started release the ignition key to neutral position.

Push the throttle control to the required speed.
For cutting 3/4 to full throttle.



WARNING!
Never run the engine indoors, in enclosed or poorly ventilated areas. The exhaust fumes contain toxic carbon monoxide.

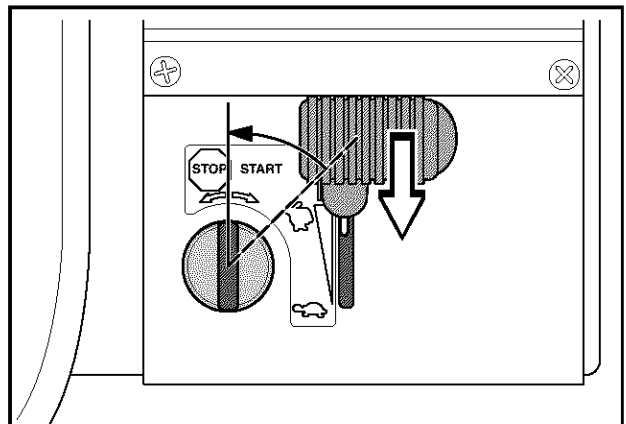

6007-007

DRIVING

Driving the machine

1. Release the parking brake by pressing down the brake pedal.

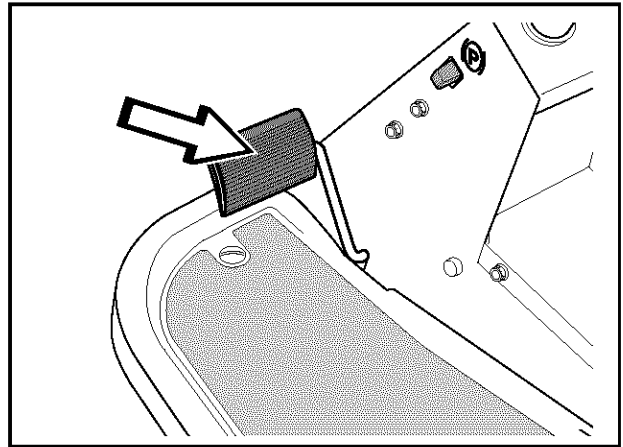

6017-012

2. Carefully press down one of the pedals until the correct speed is reached.

To drive forwards: press down pedal (1).
To reverse: press down pedal (2).

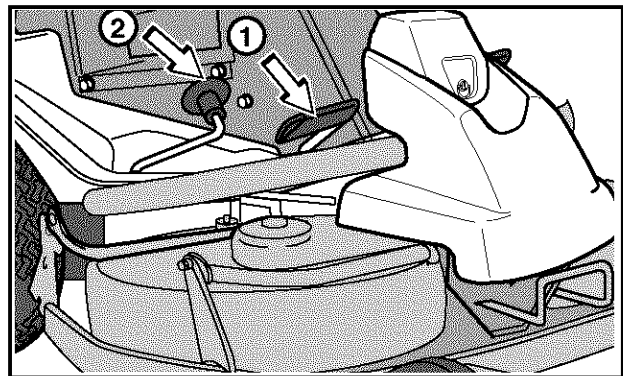

6017-214A

3. Select the required cutting height (1-9) with the cutting height lever.

To obtain a uniform cutting height it is important that the tyre pressures are equal on both front wheels 60 kPa/8.5 PSI.

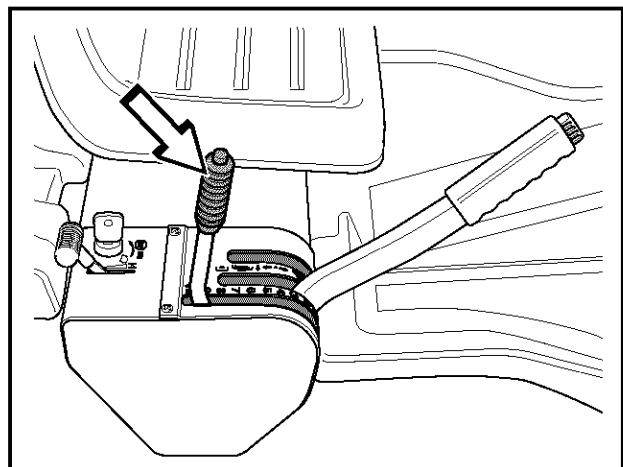

6007-008H

DRIVING

4. Push in the lock button on the lift lever and lower down the cutting unit.

IMPORTANT INFORMATION

The service-life of the drive belts increases considerably if the engine is run at low speed when engaging the blades. For this reason do not increase the throttle until the cutting unit has been lowered to the cutting position.

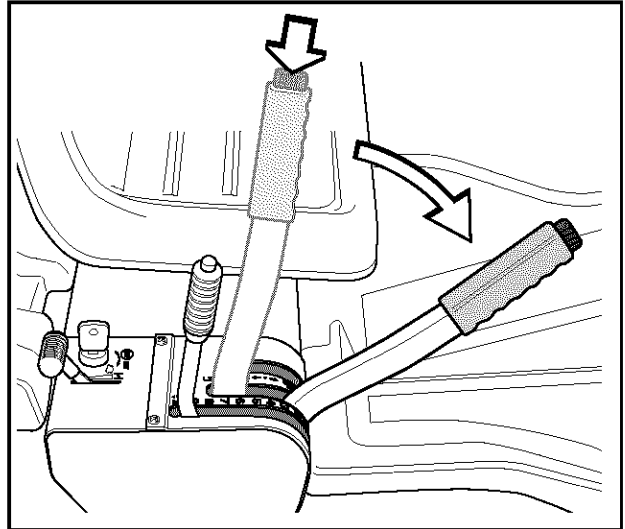

6007-009H



WARNING!

Clear the lawn from stones and other object which can be thrown out by the blades.

Cutting tips

- Localise and mark stones and other fixed objects to avoid collision.
- Start with a high cutting height and reduce down until the required cutting result are obtained.
- The cutting results are best with a high engine speed (fast rotating blades) and low driving speed (slow moving machine). If the grass is not too high and thick, the driving speed can be increased without noticeably depreciating the mowing result.
- The best lawns are achieved if the grass is cut often. Mowing becomes more uniform and the grass cuttings become more evenly distributed over the surface. The total time consumption is not greater since it is possible to select a higher driving speed without inferior mowing results.
- Avoid mowing a wet lawn. The mowing results are inferior since the wheels sink down into the soft lawn.
- Wash down the underside of the cutting unit with water after use. Do not use a high pressure jet. Put the cutting unit in the service position while doing this.
- If you use the mulching function it is important to mow the grass regularly.

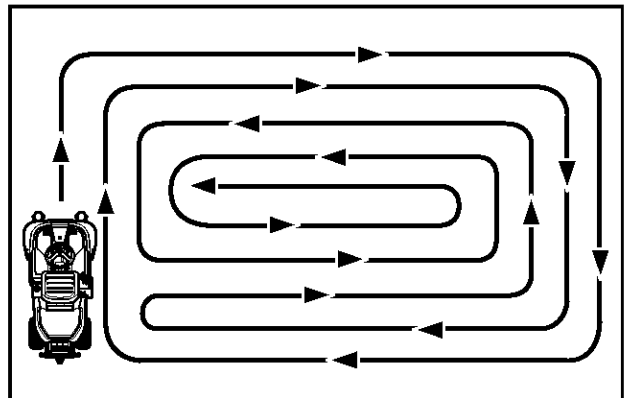

6007-212

Mowing pattern

DRIVING



WARNING!
Never drive the machine on ground with a slope of more than 15°. Mow slopes upwards and downwards, never across. Avoid sudden changes in direction.

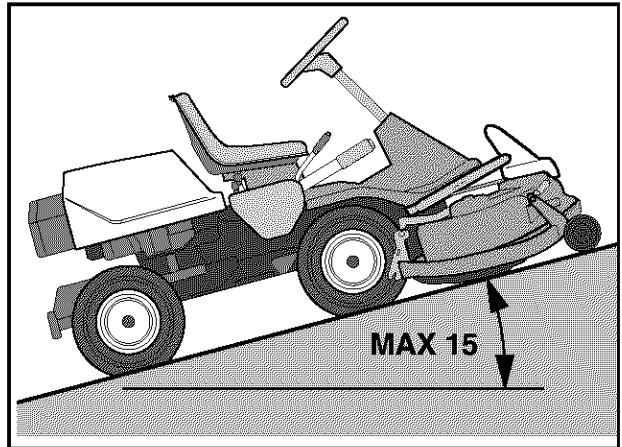

6017-002

Stopping the engine

Preferably allow the engine to idle for a minute (always min 15 sec) to obtain normal working temperature before stopping it, if it has been working hard.

1. Lift up the cutting unit by pulling the lever back to the end position.

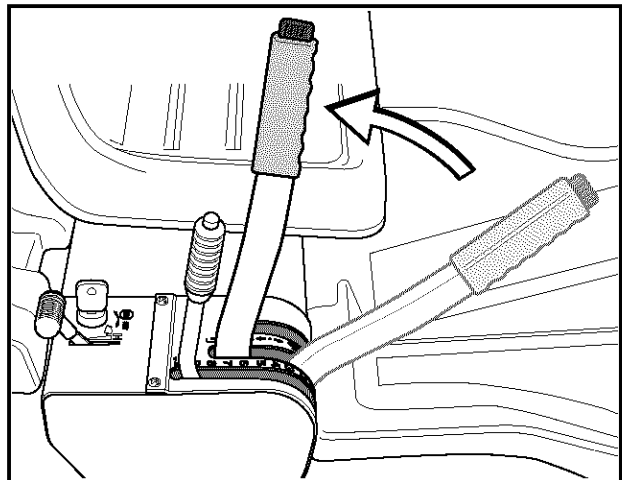

6007-014H

2. Pull back the throttle control and turn the ignition key to the STOP position.
3. When the Rider is at a standstill, press down the parking brake and push in the locking button.

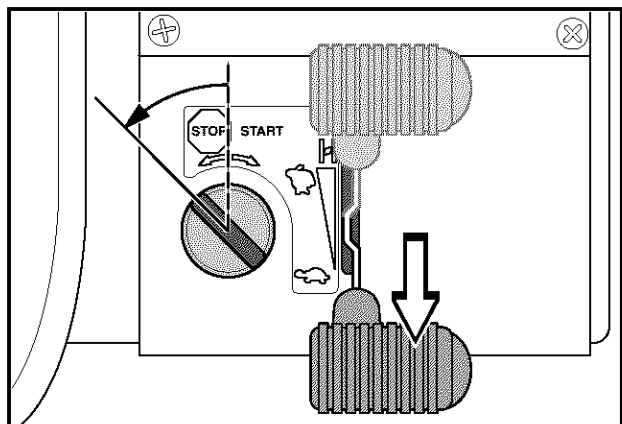

6007-015

Release lever

The release control must be pulled out in order for the Rider to be moved when the engine is shutoff.

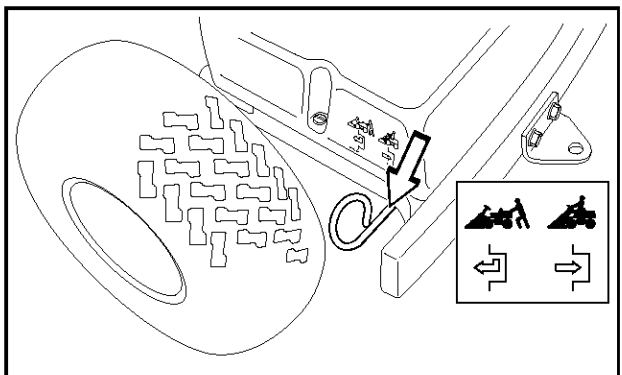

6007-217H

MAINTENANCE

Maintenance schedule

The following is a list of the maintenance which should be conducted on the machine. For the items which are not described in these instructions go to an authorised service workshop.

Maintenance	Page	Daily maintenance before start	Maintenance interval in hours			
			25	50	100	200
Check the engine's oil level	41	●				
Check the engine's cooling air inlet	30	●				
Check the steering wires	25	●				
Check the safety system	29	●				
Check screws and nuts	–	○				
Check for fuel and oil leakage	–	○				
Clean around the silencer	–	○				
Clean the air filter's prefilter ²⁾	27		●			
Check the cutting unit	33		●			
Check the tyre pressures 60 kPa/8.5 PSI	30		●			
Lubricating the belt adjuster ³⁾	42		●			
Lubricate joints and shafts ³⁾	42		●			
Check the V-belts	–		○			
Check the hydrostat's cooling fins	–		○			
Check the transmission's oil level	42			●		
Adjust the brakes	25			●		
Check and adjust the throttle wire	26			●		
Change the engine oil ¹⁾	41			● ¹⁾	● ¹⁾	
Clean the engine's and hydrostat's cooling flanges ^{2,4)}	–				○	
Replace the air filter's paper filter ²⁾	27				●	
Replace the fuel filter	26				●	
Clean or replace the spark plug	28					●
Replace the oil filter	42					●

¹⁾First change after 5 hours. Replace after every 50 hours with heavy loads or high temperatures. ²⁾During dusty conditions cleaning and replacement should be more frequent. ³⁾For daily use of the machine lubrication should be conducted twice a week. ⁴⁾Conducted by authorised service workshop.

● = Described in these instructions.

○ = Not described in these instructions.



WARNING!

No service procedures must be conducted on the engine or cutting unit unless:

- The engine is switched off.
- The ignition key is removed.
- The ignition cable is removed from the plug.
- The parking brake is applied.
- The cutting unit is disengaged.

MAINTENANCE

Removal of the machine hoods

Engine hood

The engine is accessible for servicing when the engine hood is lifted up.

Tilt the seat forward, release the rubber strap under the seat, and tilt the hood backwards.

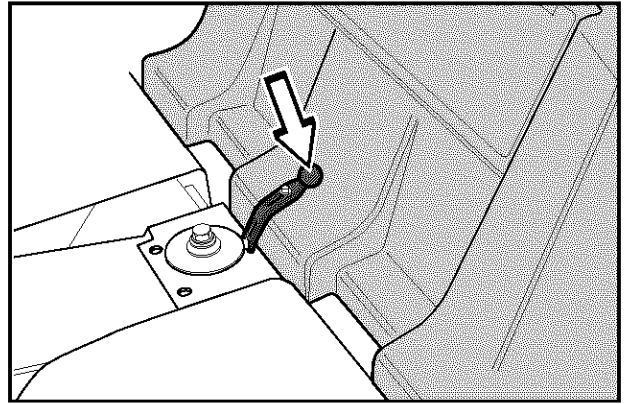

6008-001

Front hood

Release the clip on the front hood and lift off the hood.

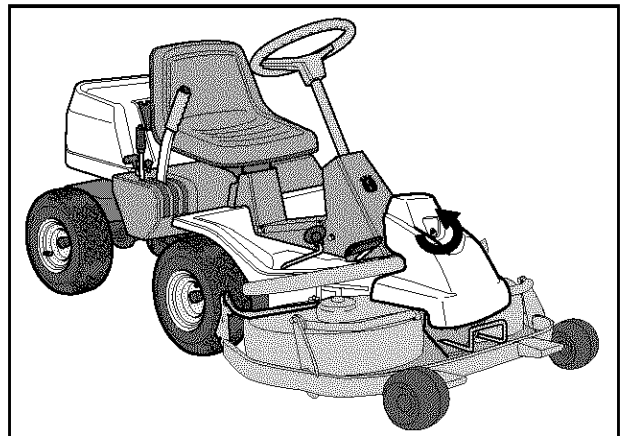

6017-215

Right-hand fender

Remove the knob (1), the screws (2 and 3) and lift off the fender.

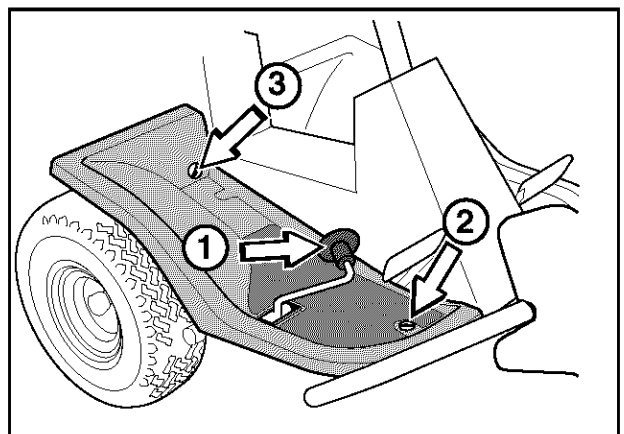

6017-003

Left-hand fender

Release the screws in the fender (2) and lift off the fender.

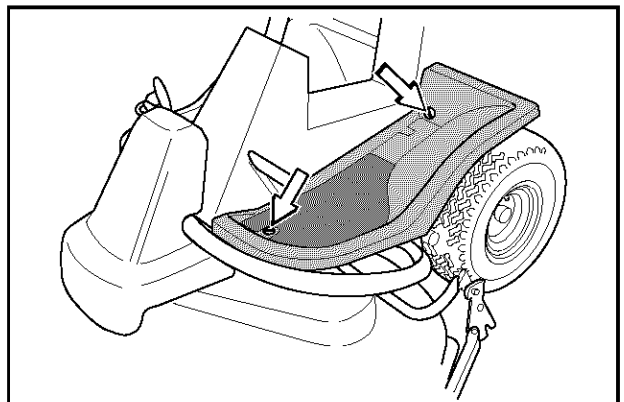

6017-013

MAINTENANCE

Checking and adjustment of the steering wires

The steering is controlled by means of wires.

These can in time become slack, which implies that the adjustment of the steering becomes altered.

Check and adjust the steering as follows:

1. Dismantle the frame-plate by releasing the screws (two on each side).
2. Check the tension of the steering wires by pushing them together as shown in the diagram. It should be possible to push them together so that the distance between them is half as much, without using unnecessary force.

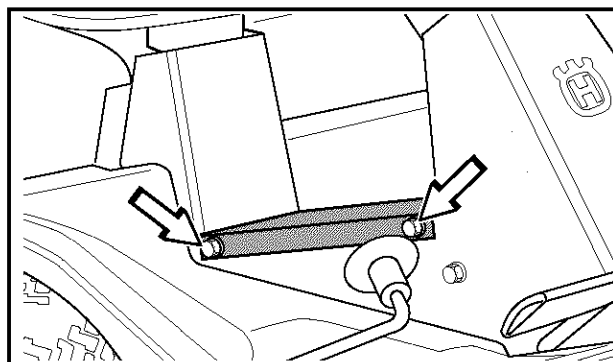

6008-008H

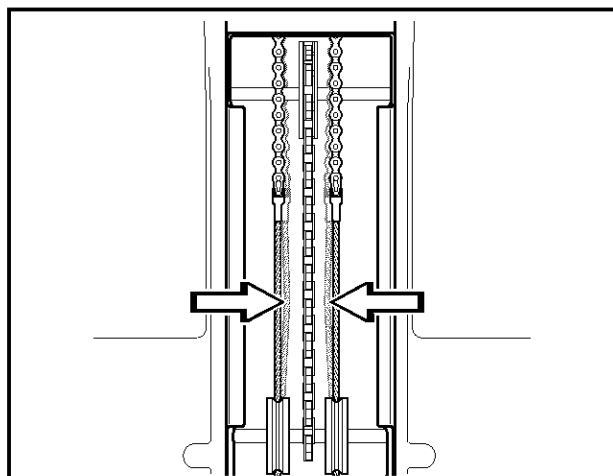

6008-009

3. If necessary, the wires can be adjusted by tightening the adjuster nuts on each side of the steering collar. Do not tension the wires too much, they should only be *tightened* against the steering collar.

Support the wire so it does not twist.

If you only tension one side the steering wheel's centre position may change.

Check the wire tension as set out in point 2 after you have made the adjustment.

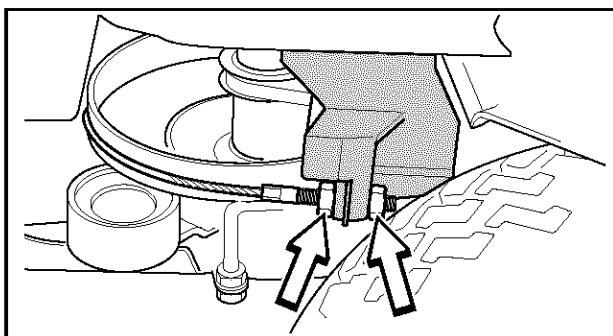

6008-010

Adjusting the brake

The brake is adjusted as follows:

1. Release the lock nuts (1).
2. Tension the wire with the adjusting screw (2) until all the play in the wire is taken up.
3. Tighten the lock nuts (1).
4. The brakes should be checked again after the adjustment has been made.

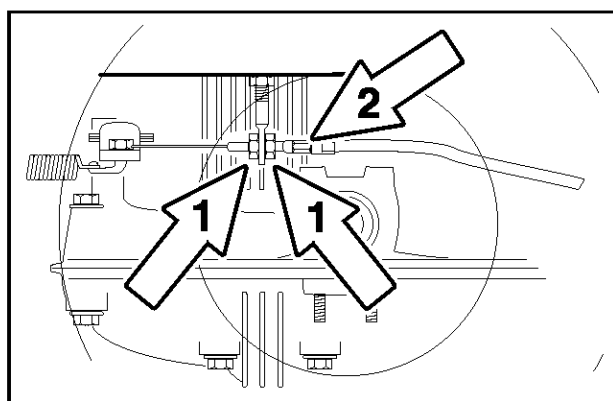

6008-239H



WARNING!
Poorly adjusted brakes can result in reduced braking power.

MAINTENANCE

Adjusting the throttle wire

If the engine does not respond as it should do when the throttle lever is moved or if the top speed is not reached, the throttle wire may need adjusting.

1. Loosen the clamping screw (by the arrow), and slide the throttle to the choke position.
2. Pull the throttle wire's casing as far as possible upwards and check that the choke is fully actuated.
3. Tighten the clamping screw.
4. Pull back the throttle to the full throttle position and check that the choke is no longer actuated. Adjust by the screw if required.

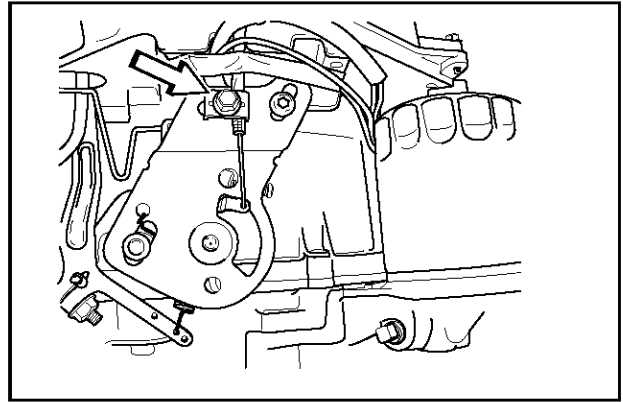

8009-455

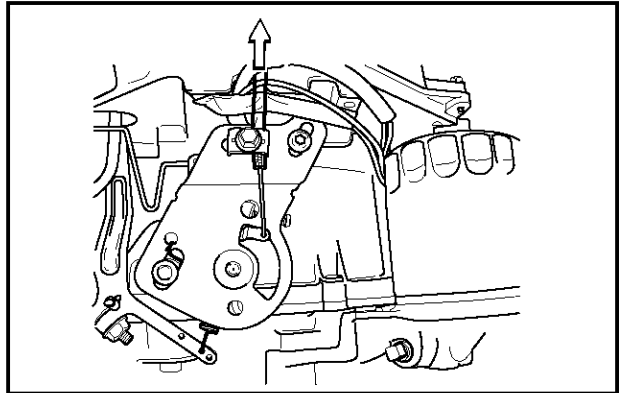

8009-469

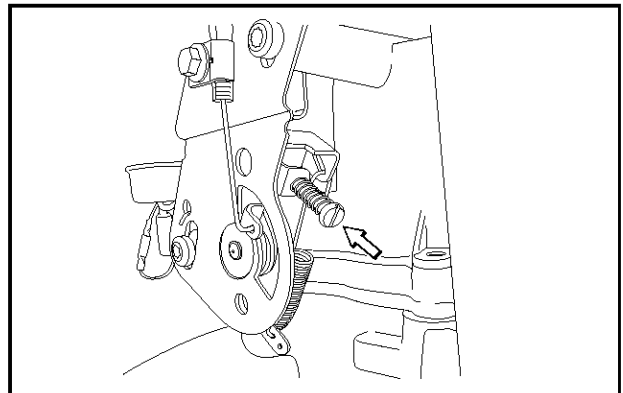

8009-456

Replacement of the fuel filter

Replace the pipe fitted fuel filter every 100 running hours (once per season) or more frequently if it is clogged.

Replace the filter as follows:

1. Fold open the engine cover.
2. Move the hose clips away from the filter. Use a pair of flat pliers.
3. Pull off the filter from the hose ends.
4. Press in the new filter on the hose ends. If necessary soap solution can be applied on the filter ends to simplify fitting.
5. Push the hose clips back on the filter.

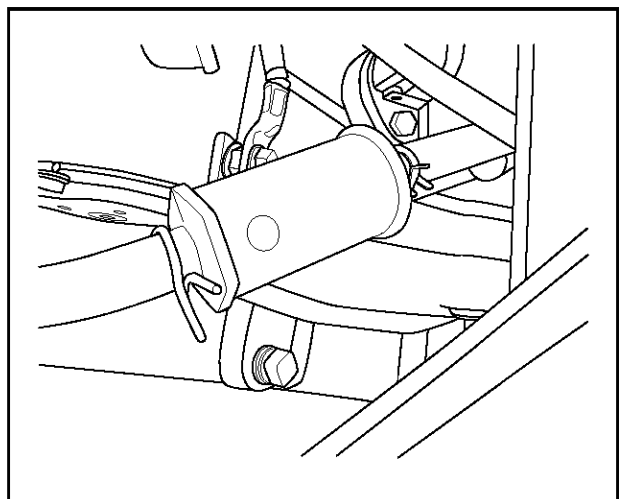

8009-457

MAINTENANCE

Service of the air filter

If the engine seems to lack power or goes irregularly the reason may be that the air filter is clogged.

It is therefore important to service the air filter at regular intervals (see "Maintenance schedule" for correct service interval).

1. Fold open the engine cover.
2. Unscrew the wing nut (A) on top of the air filter and remove the cover.
3. Carefully remove the precleaner. Wash and reoil the precleaner every 25 hours of operation. Wash the precleaner in warm water with detergent. Rinse precleaner with clear warm water. Squeeze water out (do not wring to avoid tearing). Allow to dry before lightly oiling with fresh engine oil and installing it over the paper filter.
4. Replace the paper filter every 100 hours or if it is clogged with dirt. Unscrew the wing nut (B) and remove the paper filter.

IMPORTANT INFORMATION

Never use compressed air to clean the air filters.

Paper filter should not be oiled or washed. It should be assembled dry.

5. The paper filter may be carefully tapped on a hard surface to remove dust. Do not try to wash or blow it with compressed air.
6. Insert the paper filter and check that it is correctly sealed to its seat. Tighten the paper filter wing nut and install the precleaner over the paper filter.
7. Fit the air filter cover and tighten its wing nut.

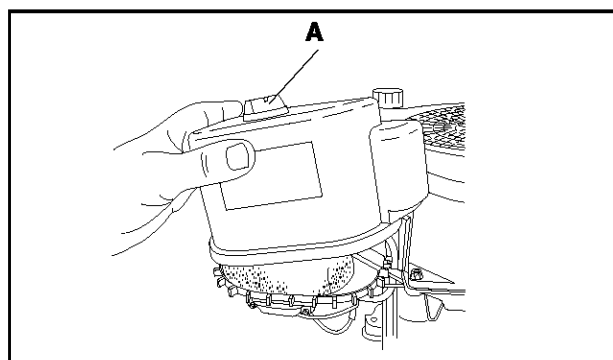

8009-458

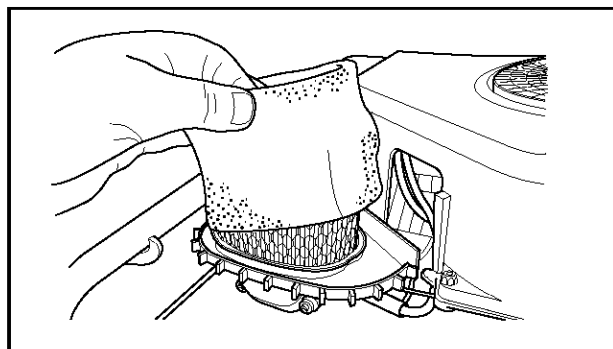

8009-459

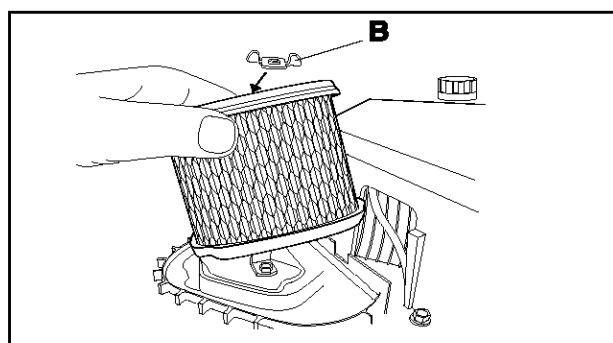

8009-460

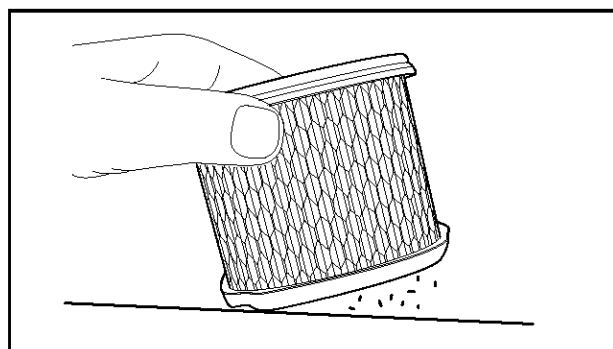

8009-461

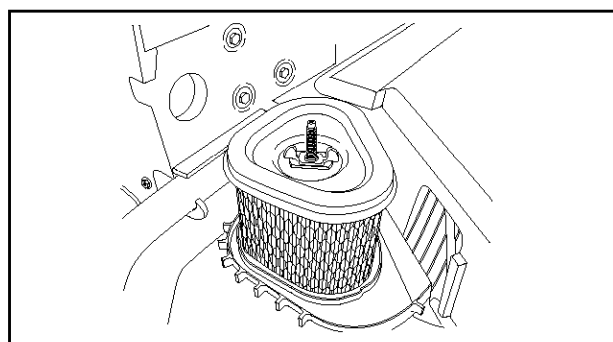

8009-462

MAINTENANCE

Battery

The battery is maintenance free. Check cables and connections for abrasion and oxidation.



WARNING!

Procedures on contact with acid

External: Rinse well with plenty of water.

Internal: Drink large quantities of water or milk. Contact a doctor as soon as possible.

Eyes: Rinse well with plenty of water. Contact a doctor as soon as possible.

Batteries emit explosive gas. Sparks, flames and cigarettes must absolutely not be brought into the vicinity of the battery.

Ignition system

The engine is equipped with an electronic ignition system. Only the spark plug requires maintenance.

For recommended spark plug, see chapter "Technical data".

IMPORTANT INFORMATION

Fitting the wrong spark plug type can damage the engine.

1. Remove the ignition cable shoe and clean around the spark plug.
2. Remove the spark plug with a 5/8" (16 mm) spark plug socket wrench.
3. Check the spark plug. Replace the spark plug if the electrodes are burned or if the insulation is cracked or damaged. Clean the spark plug with a steel brush if it is to be reused.
4. Measure the electrode gap with a gapping tool. The gap should be 1.02 mm/0.040". Adjust as necessary by bending the side electrode.
5. Reinsert the spark plug, turning by hand to avoid damaging the threads.
6. After the spark plug is seated, tighten it with 38-43 Nm (28-32 lbft).
7. Replace the ignition cable shoe.

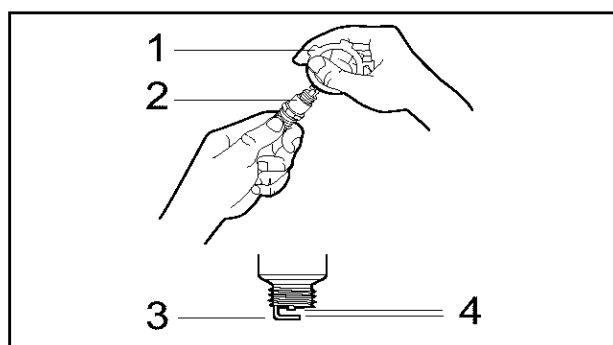

8009-468

1. Wire gauge
2. Spark plug
3. Side electrode
4. Gap

IMPORTANT INFORMATION

Inadequately tightened spark plugs can cause overheating and damage the engine. Tightening the spark plug too much can damage the threads in the cylinder head.

MAINTENANCE

Inspecting the safety system

The Rider is equipped with a safety system that prevents starting or driving under the following conditions:

The engine should only be possible to start when the cutting unit is in its raised position and the hydrostat pedals are in the neutral position.

The driver does not need to be seated in the driver's seat.

Make daily inspections to ensure that the safety system works by attempting to start the engine when one of the conditions is not met. Change the conditions and try again.

Check that the engine stops if you temporarily move out off the driver's seat while the cutting unit is lowered or the hydrostat pedals are not in the neutral position.

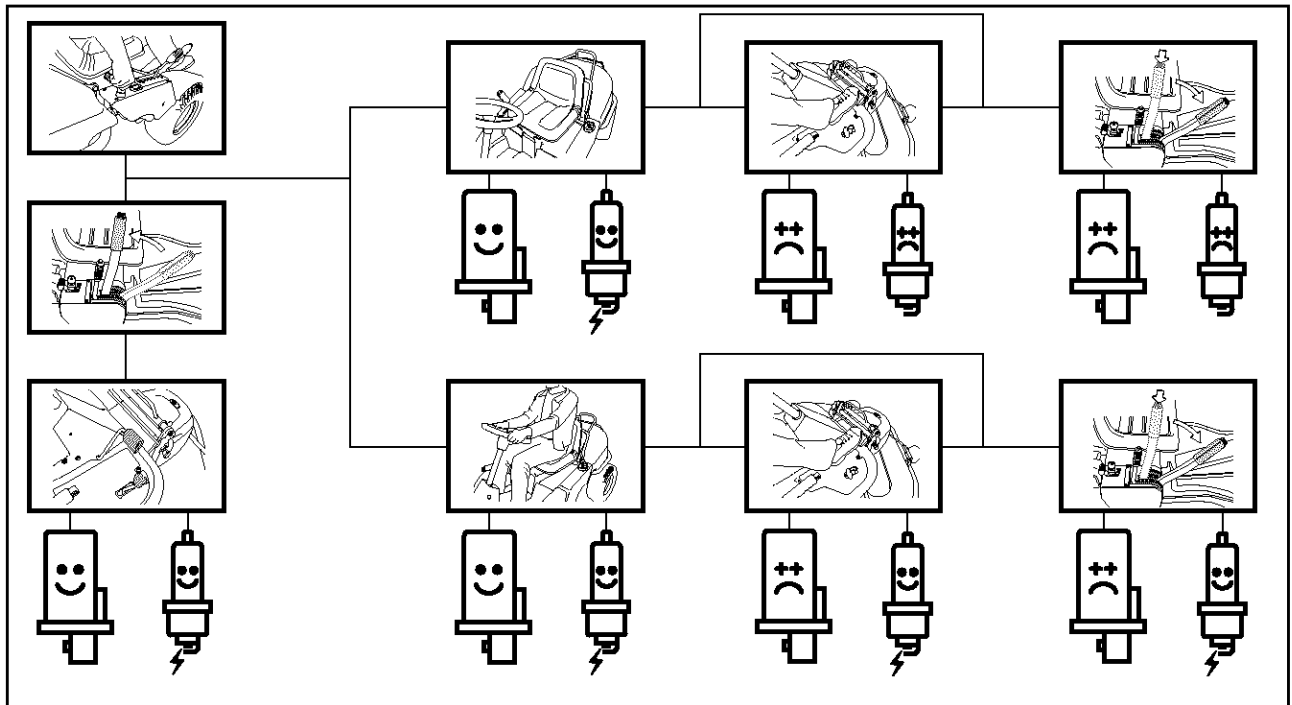
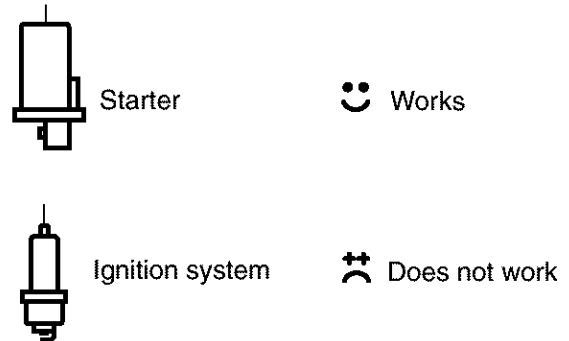

MAINTENANCE

Main fuse

The fuse is located in a loose holder under the battery case cover, in front of the battery.

Type: Flat-blade U-link, 15 A.

Do not use any other type of fuse when replacing. A blown fuse indicates that the U-link has burnt off.

Pull the fuse out of the holder when replacing.

The fuse is used to protect the electrical system. If it blows again shortly after replacing this is due to a short circuit, which must be rectified before the machine is used again.

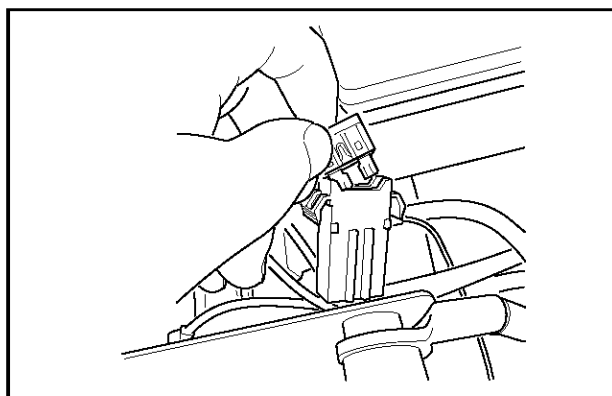

8009-370

Checking the tyre pressure

The tyre pressure should be 60 kPa (0.6 kp/cm²/8.5 PSI) all round.

To improve driving, the pressure on the rear tyres can be reduced to 40 kPa (0.4 kp/cm²/5.6 PSI).

The maximum tyre pressure is 100 kPa (1.0 kp/cm²/14 PSI).

IMPORTANT INFORMATION

Different tyre pressures on the front tyres will result in the blades cutting the grass at different heights.

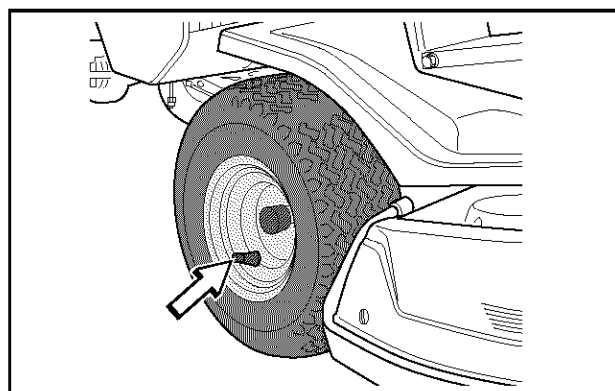

8008-030

Check the engine's cooling air intake

Clean the air intake grille in the engine cover behind the driver's seat.

Fold open the engine cover.

Check that the cooling intake is free from leaves, grass and dirt.

Check the air duct, located on the inside of the engine cover, ensure it is clean and does not rub against the cooling air intake.

If the cooling intake is blocked this will interfere with the cooling of the engine, which can damage the engine.

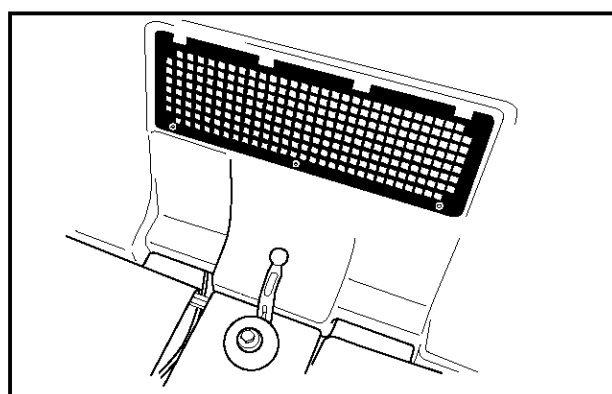

Air intake grille

8009-431



WARNING!
The cooling air intake rotates when the engine is running. Mind your fingers.

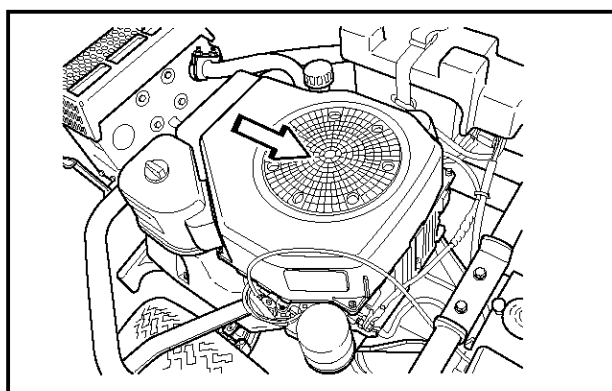

Cooling air intake

8009-470

MAINTENANCE

Fitting the cutting unit

1. Place the Rider on a flat surface and apply the parking brake. Check that the lever for setting the cutting height is in the lowest position.

Make sure the support wheels are fitted to the cutting unit (1).

2. Grasp the handle at the front or hold the frame of the cutting unit (2) and slide the unit underneath the rider mower.

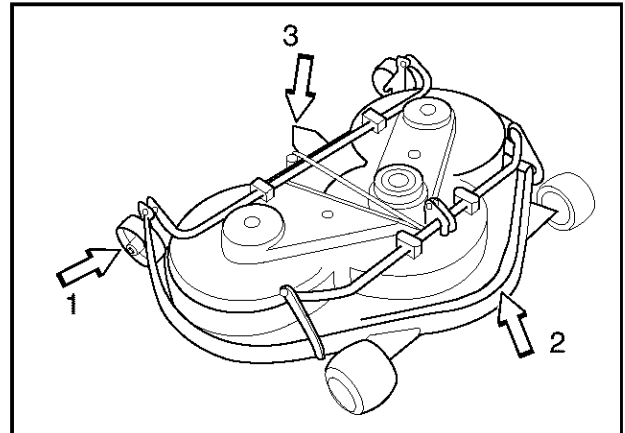

6017-159

Make sure that the tongue (3) on the cutting unit engages correctly.

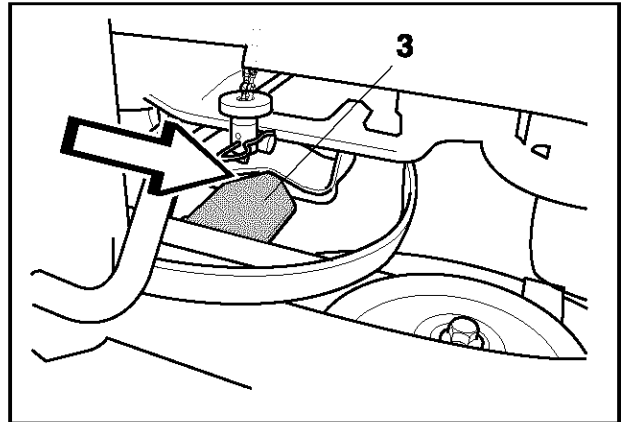

8009-438

3. Insert the bolt and secure it with a locking pin.

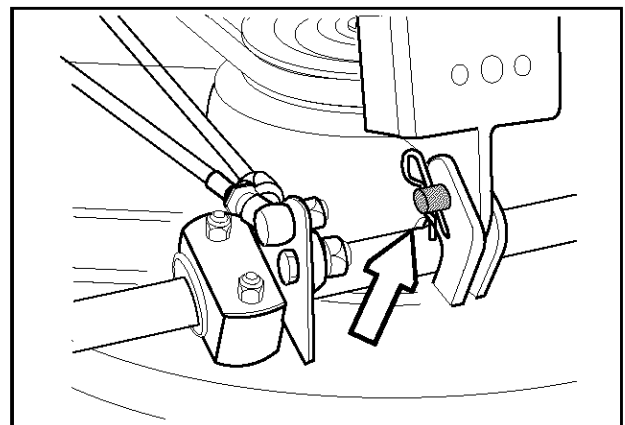
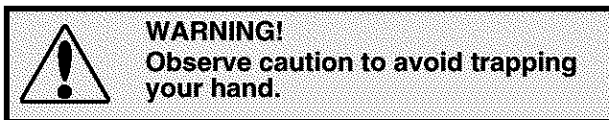

6017-128

4. Press down the frame and insert the pin. Fit the drive belt around the drive wheels of the cutting unit.
5. Hook up the height adjustment strut.



6017-160

MAINTENANCE

6. Move the support wheels to their parking position.
7. Fit the front cover.



WARNING!
Wear protective glasses when installing or removing the cutting unit. The collet spring which tensions up the belt can go off and cause personal injury.

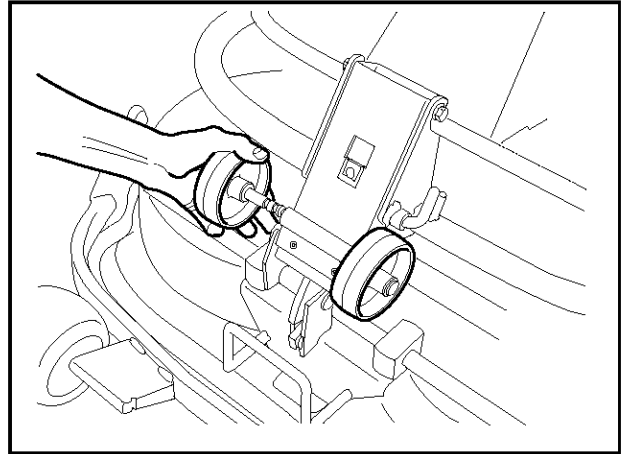

8009-439

8. Secure the collet spring.

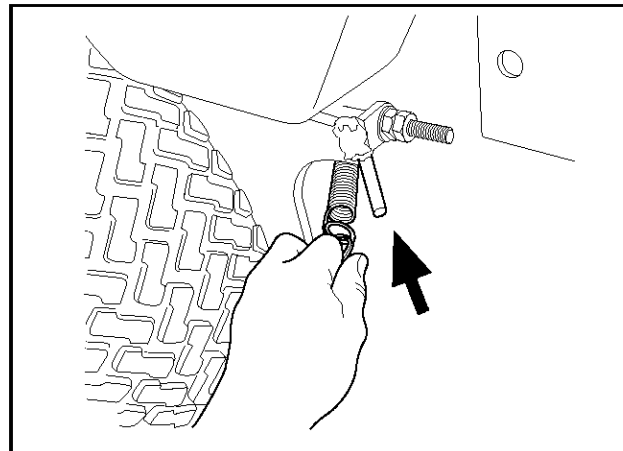

8009-440

Removing the cutting unit

1. Carry out points 1-9 to put the cutting unit in the service position, see "Service position for the cutting unit".
2. Remove the bolt (3) and lift off the cutting unit.

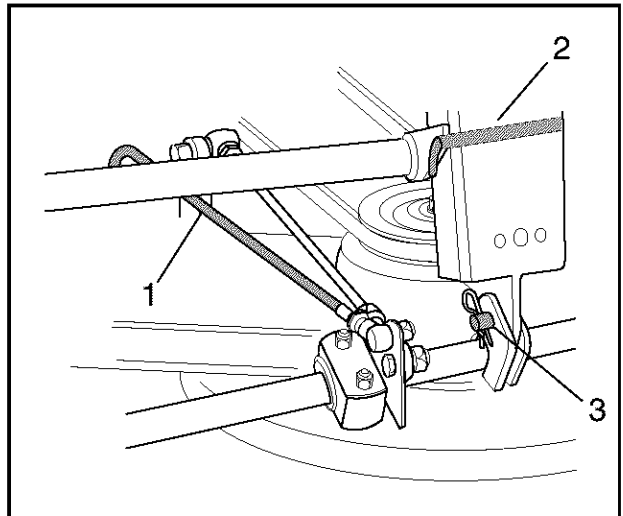

6017-021

MAINTENANCE

Checking and adjustment of the cutting unit's ground pressure

To achieve the best cutting results the cutting unit should follow the underlying surface without pressing too hard against it.

The pressure is adjusted with a screw on each side of the machine.

1. Check the air pressure in the tyres 60 kPa (0.6 kp/cm²/8.5 PSI).
2. Place the Rider on a flat surface.
3. Put the lifting lever in the mowing position.
4. Place a set of bathroom scales under the cutting unit's frame (front edge) so that it rests on the scales. If necessary a block can be placed between the frame and scales so that the support wheels do not bear any weight.

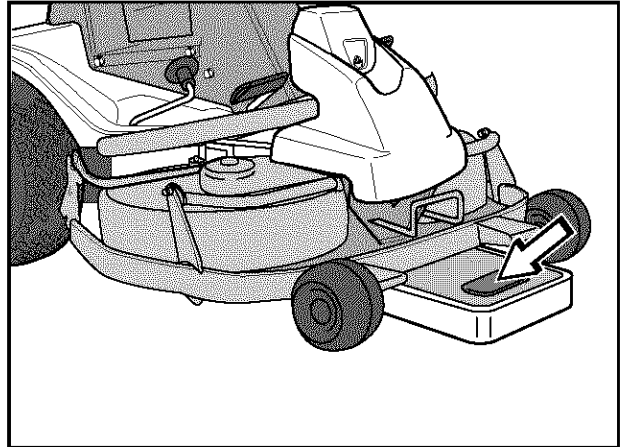

6017-216

5. Adjust the unit's ground pressure by screwing in or out the adjusting screws located behind the front wheels on both sides.

The ground pressure should be between 12 and 15 kg (26.5-33 lb).

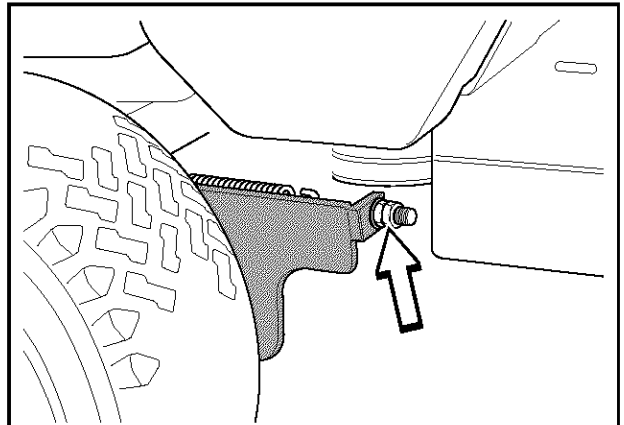

6008-019

MAINTENANCE

Checking the cutting unit's parallelism

Check the parallelism of the cutting unit as follows:

1. Check the air pressure in the tyres 60 kPa (0.6 kp/cm²/8.5 PSI).
2. Place the machine on a level surface.
3. Put the lifting lever in the mowing position.
4. Measure the distance between the ground and the front and rear edges of the cutting unit hood. The cutting unit should slope forwards slightly so that the rear edge is 2-4 mm (1/8") higher than the front edge.

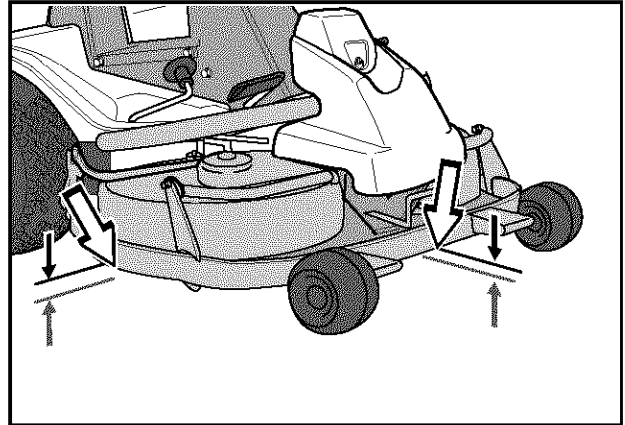

6017-217

Adjusting the parallelism of the cutting unit

1. Remove the front hood and right-hand fender.
2. Undo the nuts on the lift strut.
3. Screw out (extend) the stay to raise the rear edge of the cover.
Screw in (shorten) the stay to lower the rear edge of the cover.
4. Tighten the nuts after adjustment.
5. On completion of the adjustment the unit's parallelism should be re-checked.
6. Fit the right-hand fender and the front hood.

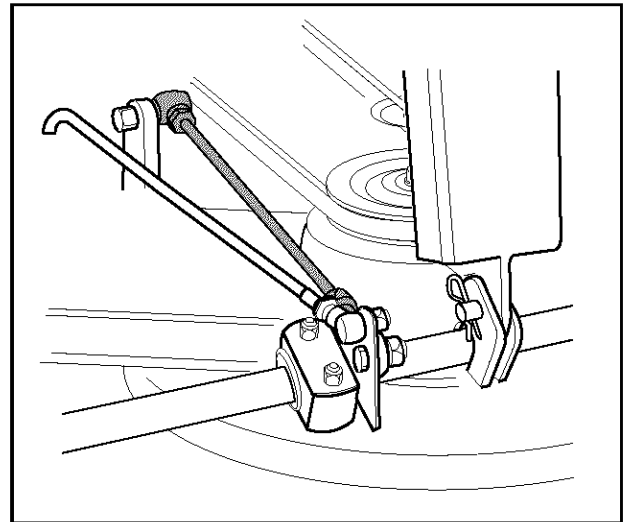

6017-018

MAINTENANCE

Replacing the cutting unit belt

1. Remove the cutting unit.
2. Remove the front bolt from the parallel strut and tip the strut backwards. Push the height adjustment strut forwards.

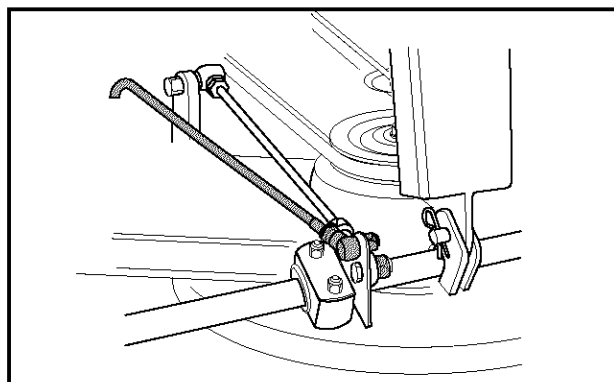

3. Loosen the two bolts holding the protective hood and then lift off the hood.

Useful hint: Mark the positions of the blades on the respective pulley using a felt-tip pen.



WARNING!
Wear gloves to protect your hands when working with the blades.

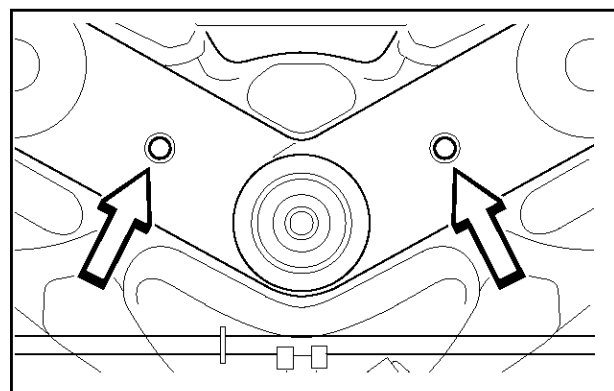

4. Loosen the three bolts 1/2 - 1 turn. Press the sides of the belt together to give maximum slack and tighten one of the bolts. Replace the belt and tighten as shown (see decal on cover). Set the blades at 90° to each other and loosen the bolt again. The spring ensures the correct belt tension. Check the positions of the blades again and adjust if necessary by repositioning the belt on the teeth. Tighten the three bolts to 45 Nm/32 lbf.

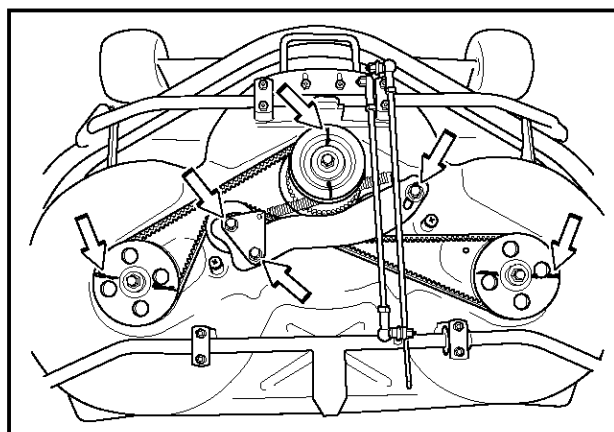

IMPORTANT INFORMATION

The blades on a Combi 103 unit should be set at 90 degrees to each other. In all other cases the blades can collide and cause serious damage to the cutting unit.

5. Fit the protective cover over the belts and replace the parallelism arm.

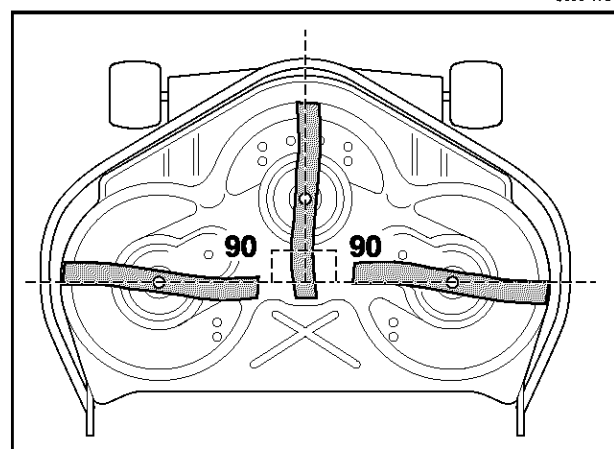

MAINTENANCE

Service position for cutting unit

The cutting head can be placed in the service position to provide easy access for cleaning, repairs and servicing. In the service position the cutting unit is raised and locked in the vertical position.

Placing in service position

1. Position the machine on flat ground. Apply the parking brake (A).
Adjust the cutting unit to the lowest cutting height and lower the cutting unit (B).

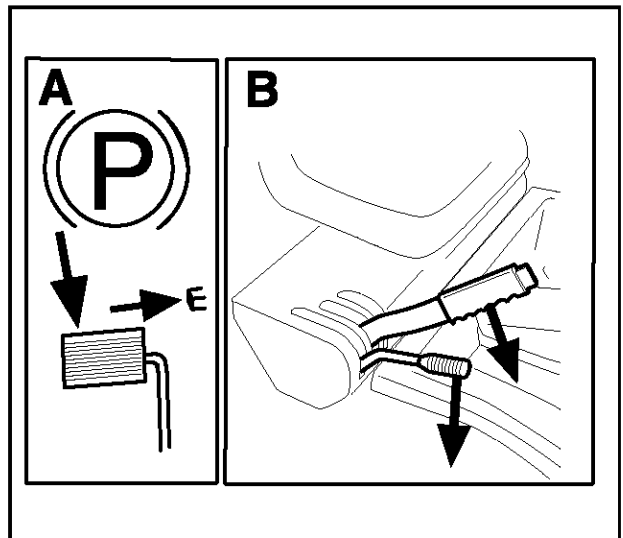

8009-437

2. Remove the front hood by removing the pin.
(There are complete instructions on using the service position inside the front hood).

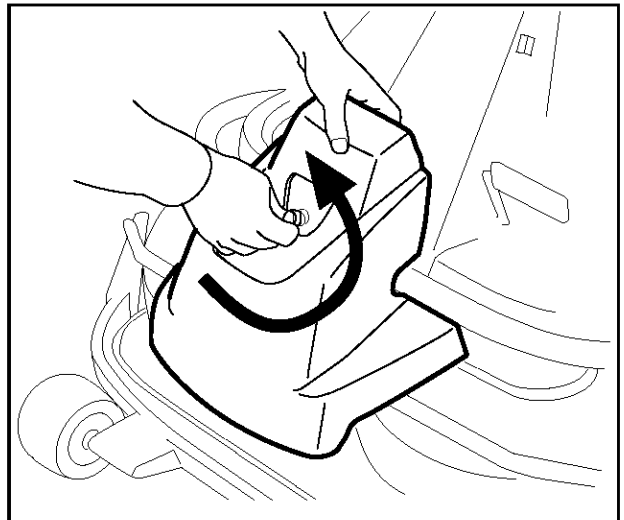

6017-219

3. Remove the two support wheels from under the front hood.

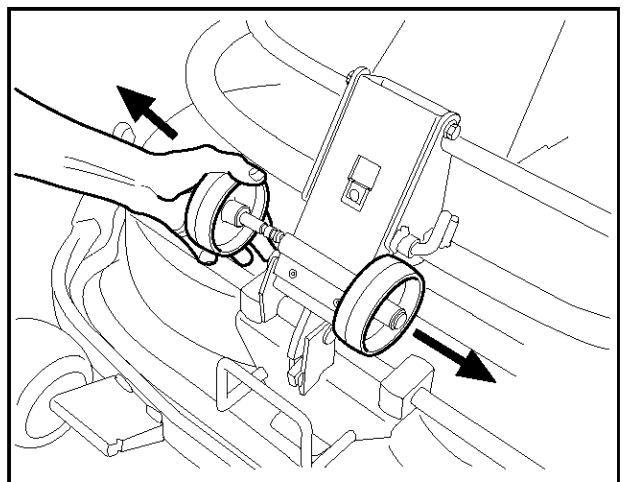

6017-220

MAINTENANCE

4. Fit the support wheels on either side of the rear of the cutting unit.



WARNING!
Wear protective glasses when dismantling the cutting unit. The spring which tensions up the belt can go off and cause personal injury.

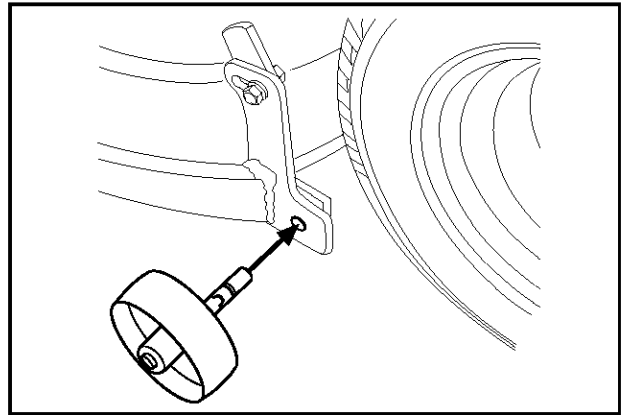

6017-221

5. Disengage the spring for the drive belt tensioning wheel.

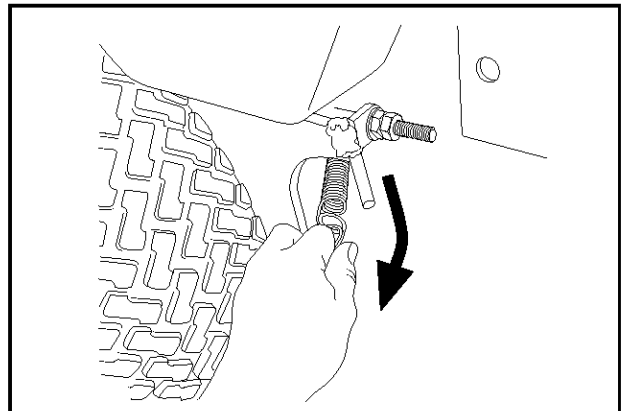

6017-222

6. Place a foot on the front edge of the cutting unit near the wheel and raise the front edge of the unit to make it easier to remove the lift strut.

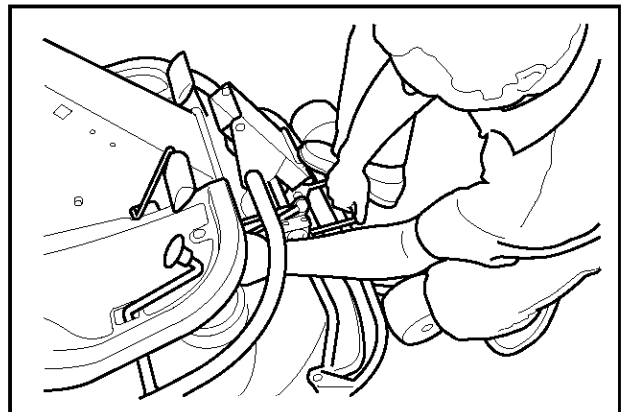

8009-122

7. Engage the strut in the holder.

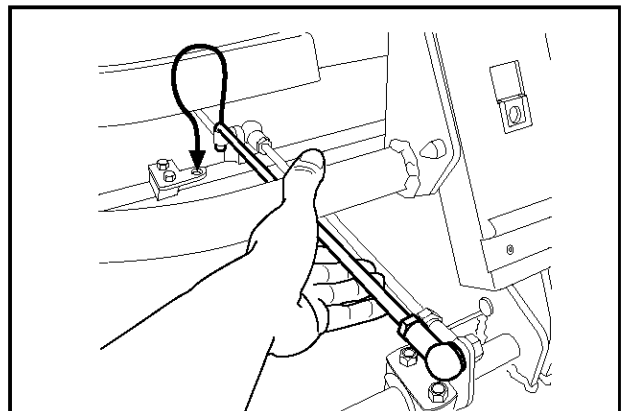

6017-223

MAINTENANCE



8. Lift off the drive belt (1). Then pull out the pin (2).

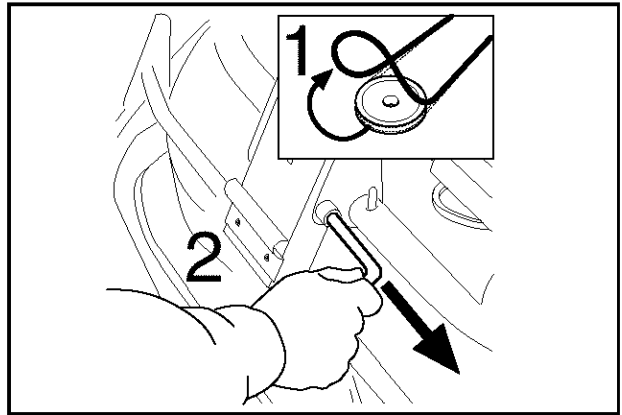

9. Pull the frame forwards and refit the pin.

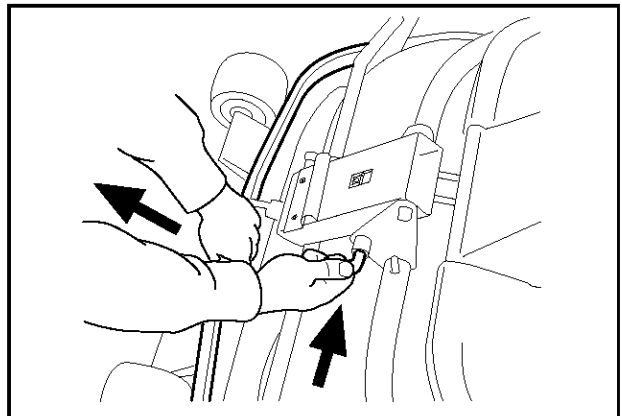

10. Grasp the front edge of the cutting unit, pull out and raise into the service position.

If the cylindrical bolt, which is now holding the cutting unit is removed, the cutting unit can be lifted off.

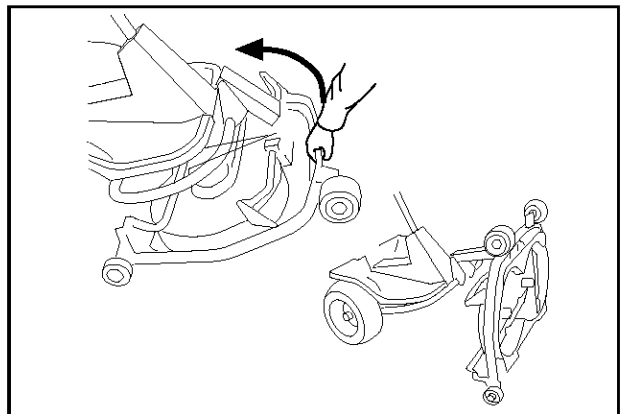

Restoring from service position

To leave the service position, reverse the procedures set out in "Placing in the service position". Make sure that the cutting unit's "lug" (3) enters the loop correctly on the underside of the machine, see diagram.

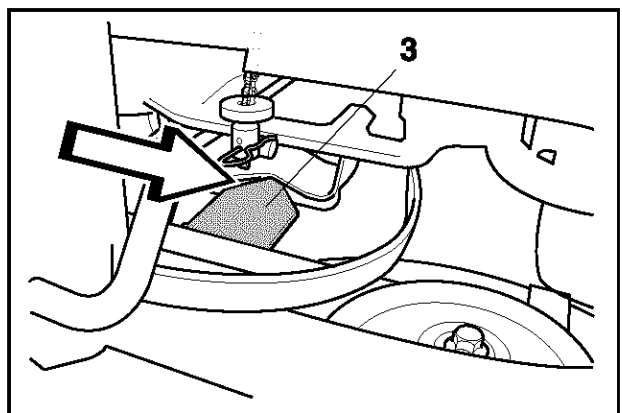

MAINTENANCE

Checking the blades

To achieve the best mowing results it is important that the blades are undamaged and well-sharpened.

Check that the blades' attachment screws are tight.

IMPORTANT INFORMATION

Replacing or sharpening the blades should be conducted by an authorised service workshop.

The blades should be balanced after sharpening.

Damaged blades should be replaced when hitting obstacles that result in a breakdown. Let the servicing dealer judge whether the blade can be repaired/ground or must be discarded.

IMPORTANT INFORMATION

Combi unit 103 should always have the blades in the relative position shown in the diagrams with an angle of 90° between the blades. Otherwise the blades can go against each other and damage the unit.

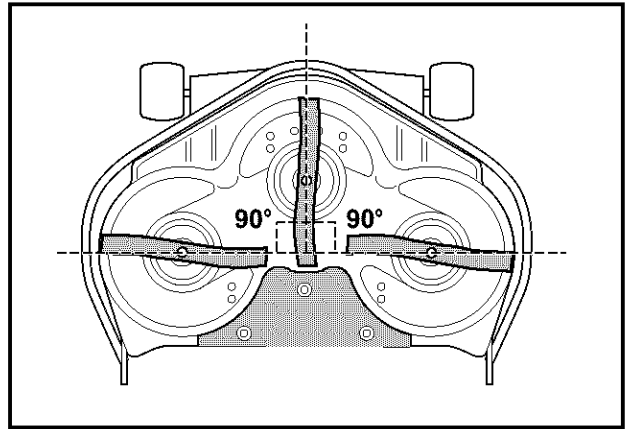

Combi 103

8009-432

MAINTENANCE

Replacing the break-pin

The blades are fitted with a break-pin to protect the Combi unit and its drive when colliding with obstacles. A domed, spring friction washer is fitted to each blade bolt. The washer must always be replaced with a new washer if the blade bolt is loosened. Otherwise the break-pin can break causing the blades to collide.

Only use original spare parts. A set containing a blade, break-pin and friction washer can be purchased from your dealer.

1. Put the cutting unit in the service position, see "Service position for the cutting unit\Placing in the service position".
2. Remove the blade (2A) by removing the blade bolt with washer and friction washer (2B).
3. Remove the remains of the broken break-pin (3).
4. Make sure the contact surfaces (4) on the blade and the blade mounting are metallic clean. Clean if necessary.
5. Fit **one** new break-pin (5) in the blade mounting.
6. Fit the blade (6), make sure it is fitted as illustrated.
7. Fit a **new** friction washer (7) with the concave face turned towards the blade.
8. Fit the blade bolt with washer (8). Tightening torque 45-50 Nm (4.5-5 kpm/32-36 lbft).

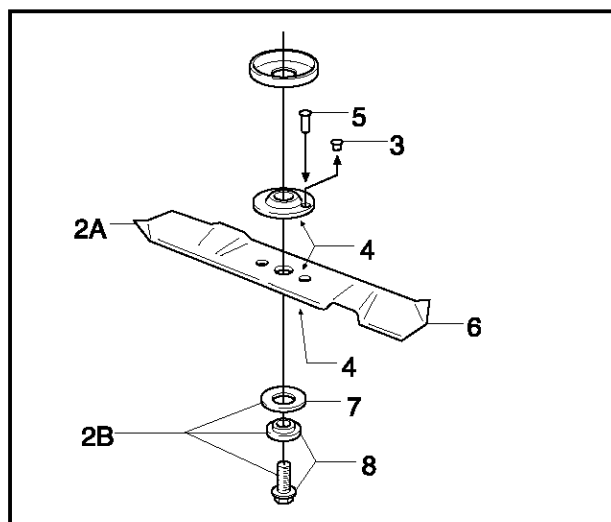

8009-137a

Removal of BioClip plug (Combi)

To change a Combi unit from BioClip function to cutting unit with rear ejection, remove the BioClip plug located under the unit with three screws.

1. Put the unit in the service position, see "Placing in the service position".
2. Remove the three screws holding the BioClip plug, and remove the plug.
3. Tip: Fit three full-thread screws M8x15 mm in the screw holes to protect the threads.
4. Replace the unit in normal position.

Fit the BioClip plug in the reverse order.

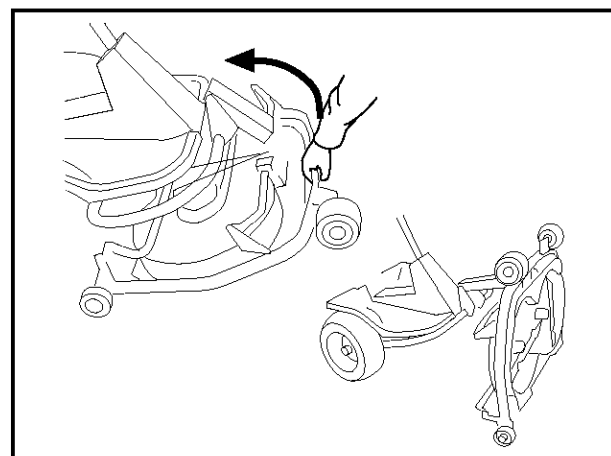

6017-227

Service position

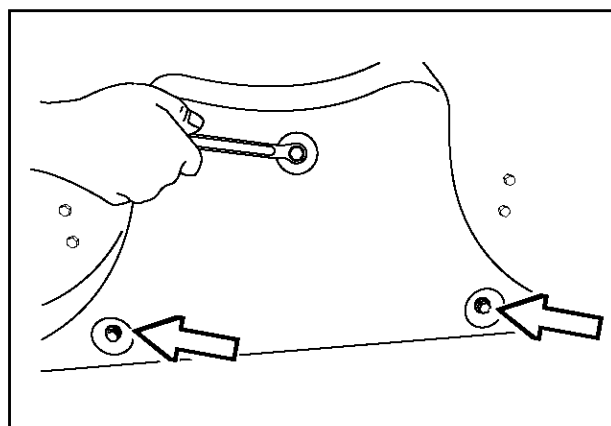

8009-289

Removal of BioClip plug

LUBRICATION

Check the engine's oil level

Check the oil level in the engine when the Rider stands horizontal with the engine switched off.

Fold open the engine cover.

Release the dip stick and pull out. Wipe off the oil and insert again.

The dip stick **must not be screwed down**.

Now release the dip stick again and pull out. Check the oil level.

The oil level should lie between the markings on dip stick. If the level approaches the "ADD" mark, top up with oil to the "FULL" mark.

The oil is filled in the same hole for the dip stick.

Fill the oil slowly. Tighten the dipstick correctly before starting the engine. Start and run the engine at idling speed for approx. 30 seconds. Turn off the engine. Wait 30 seconds and check oil level. If necessary fill so that the oil comes up to the "FULL" mark on the dipstick.

Use engine oil class SG or SH, 10W/30 above freezing point or 5W/30 below freezing point.

Do not mix different types of oil.

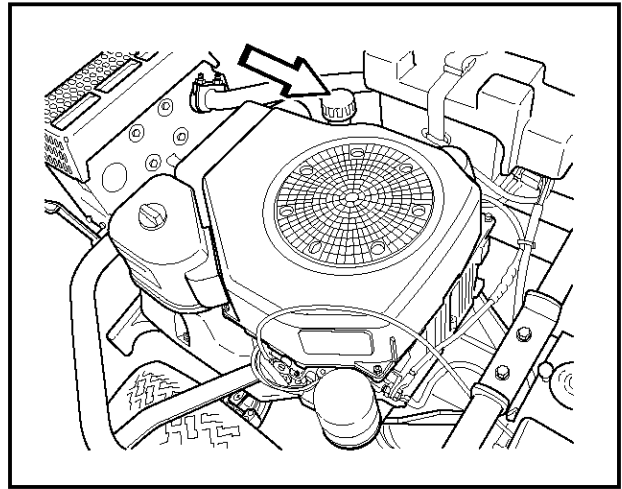

8009-471

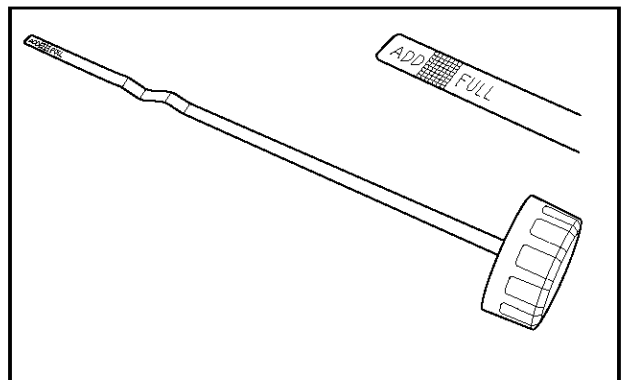

8009-464

Changing the oil

The oil should be changed for the first time after 5 hours of running time. Thereafter, it should be changed every 100 hours of running time.

With heavy loads or high temperatures replace the oil after every 50 hours.



WARNING!
Engine oil can be very hot if it is drained off directly after the engine is stopped. Therefore allow the engine to cool down first.

1. Place a receptacle under the engine oil drain plugs (A), located on the right-hand side of the engine.
2. Remove the dip stick and two drain plugs (A).
3. Let the oil run out into the receptacle.
4. Fit the drain plugs and tighten.
5. Fill up with oil to the "FULL" mark on the dip stick. The oil is filled in the same hole for the dip stick.
See "Check the engine's oil level" above for filling instructions. The engine holds 1.9 litres (1.8 USqt) of oil.
6. Run the engine warm and then check that there is no leakage from the drain plugs.

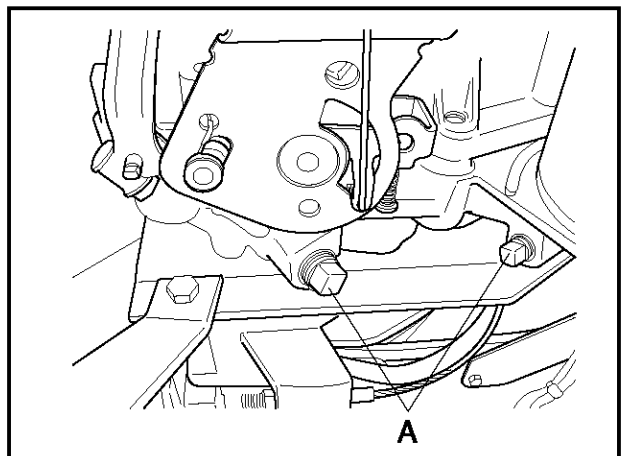

8009-465

IMPORTANT INFORMATION

Used engine oil and oil filters are hazardous to health and environment and must in accordance with the law not be poured out on the ground or in the nature, and must be handed in to a workshop or other designated station for treatment. Avoid skin contact, wash with soap and water in the event of spillage.

LUBRICATION

Change of oil filter

Replace oil filter every 200 operating hours. Drain oil first using the plug on the filter base. Remove the old filter using an oil filter tool. Lightly coat rubber gasket with new oil, then install filter by turning it to the right until hand tight. Tighten the filter an additional 1/2 turn. Check that the drain plug is reinstalled before starting the engine.

Start engine and check for leakage.

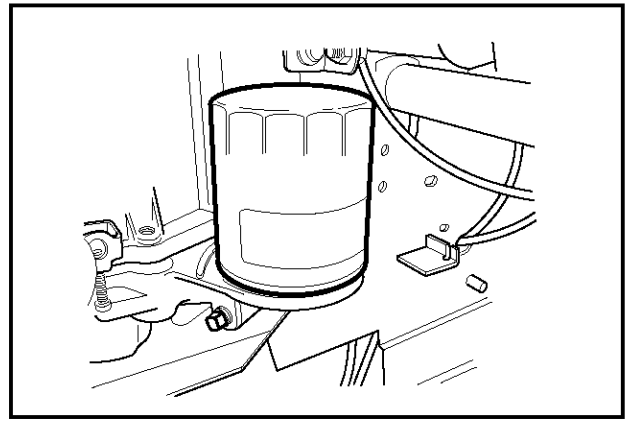

Check the transmission's oil level

1. Remove the transmission cover. Loosen both screws (one on each side) and lift off the transmission cover.
2. Check that there is oil in the transmission's oil tank. Fill if necessary with engine oil SAE 10W/30 (class SF-CC).

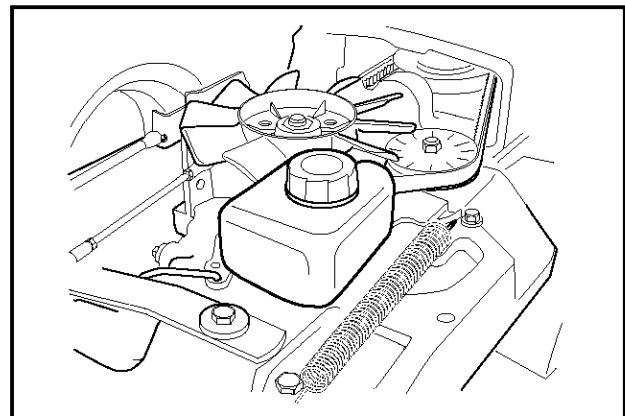
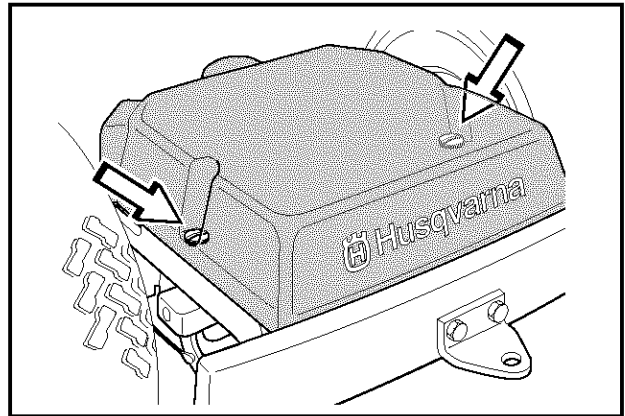

Lubricating the belt adjuster

The belt adjuster should be lubricated regularly using good quality molybdenum disulphide grease*.

1 nipple from the right-hand side under the engine's lower belt pulley, until grease is forced out.

With daily use lubrication should be conducted twice a week.

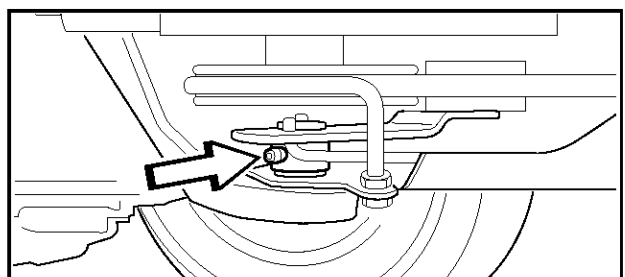

General lubrication

All joints and bearings are lubricated on manufacture with molybdenum sulphide grease. Re-grease with same type of grease*. Lubricate the steering and control wires with engine oil.

The machine should be lubricated regularly, and twice a week when used daily.

* Grease from well-known brand names (petrol companies, etc.) usually maintains a good quality. The most important property is that the grease provides good protection against corrosion.

TROUBLE SHOOTING SCHEDULE

Problem	Procedure
Engine will not start.	<ul style="list-style-type: none">• Fuel tank empty.• Spark plug defective.• Spark plug connection defective.• Dirt in carburettor or fuel pipe.
Starter does not pull round engine.	<ul style="list-style-type: none">• Battery flat.• Bad contact between cable and battery terminal.• Lift lever for cutting unit in wrong position.• Main fuse blown. The fuse is placed in front of the battery, under the battery cover.• Ignition lock faulty.• Gear shift/hydrostat pedal not in neutral.• Hydrostat pedals not in the neutral position.• Faulty starter or starter circuit
Engine does not run smoothly.	<ul style="list-style-type: none">• Spark plug defective.• Carburettor incorrectly set.• Air filter clogged.• Fuel tank vent blocked.• Ignition setting defective.• Dirt in carburettor or fuel pipe.• Choking or incorrectly adjusted throttle cable.
Engine seems to have no power.	<ul style="list-style-type: none">• Air filter clogged.• Spark plug defective.• Dirt in carburettor or fuel pipe.• Carburettor incorrectly set.• Choking or incorrectly adjusted throttle cable
Engine overheats.	<ul style="list-style-type: none">• Engine overloaded.• Air intake or cooling flanges blocked.• Fan damaged.• Too little or no oil in engine.• Ignition defective.• Spark plug defective.
Battery does not charge.	<ul style="list-style-type: none">• One or more cells faulty.• Bad contact between battery terminals and cables.
Machine vibrates.	<ul style="list-style-type: none">• Blades are loose.• Engine is loose.• Imbalance on one or more blades, resulting from damage or inferior balancing after sharpening.
Uneven mowing.	<ul style="list-style-type: none">• Blades blunt.• Cutting unit skew.• Long or wet grass.• Grass blockage under hood.• Different tyre pressures on right and left sides.• Over-speeding.• Drive belts slipping.• The blade has a broken break-pin.

STORAGE

Winter storage

At the end of the season the machine should immediately be put in order for storage, also if it is going to stand idle for more than 30 days. Fuel which is left to stand for long periods (30 days or more) can leave tacky deposits which can block the carburettor and interfere with the engine.

Fuel stabiliser is an acceptable alternative to avoid tacky deposits during storage. Add stabiliser to the fuel in the tank or the storage container. Always use the mixing ratios indicated by the manufacturer. Run the engine for at least 10 minutes after adding the stabiliser so that it will reach the carburettor. Do not empty the fuel tank and carburettor if stabiliser has been added.



WARNING!

Never place an engine with fuel in the tank indoors or in poorly ventilated areas where petrol fumes can come into contact with naked flames, sparks or pilot flames in boilers, hot water heaters, or drying cabinets, etc. It is highly inflammable and negligent usage can cause severe person injury and material damage. Drain off the fuel in an approved container outdoors and well clear of naked flames. Never use petrol for cleaning purposes. Use degreasing agents and hot water instead.

To put the machine in order for storage follow these instructions:

1. Carefully clean the machine, especially under the cutting unit. Touch-up paint damage to avoid rust.
2. Inspect the machine for worn or damaged parts and tighten loose screws and nuts.
3. Change the oil, and take care of the waste oil.
4. Empty the fuel tank. Start the engine and run it until the carburettor is emptied of fuel.
5. Remove the spark plug and pour about a tablespoon of engine oil in the cylinder. Turn over the engine so that the oil is evenly distributed and then refit the spark plug.
6. Grease all grease nipples, joints and axles.
7. Remove the battery. Clean it, charge it, and store it in a cool place.
8. Store the machine in a clean and dry place and cover it over for extra protection.

Cover

There is a cover to protect your machine during storage or transport. Contact your dealer for a demonstration.

Service

When ordering spare parts state the purchase year, model, type, and serial number.

Always use genuine parts.

Annual inspection or trimming by an authorised service workshop is a good way of getting the best out of your machine the next season.

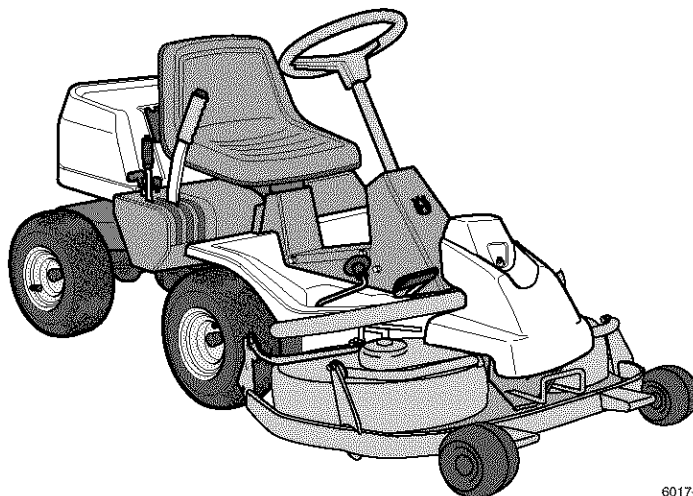

6017-213

TECHNICAL DATA

Dimensions

Length incl. cutting unit	2200 mm/7.22 ft
Width incl. cutting unit	1110 mm/3.64 ft
Height	1060 mm/3.52 ft
Weight	282 kg/622 lb including Combi 103 unit
Wheel base	855 mm/2.8 ft
Track	Front 715 mm/2.34 ft, rear 625 mm/2.05 ft
Tyre size	16 x 6.50 x 8
Tyre pressure, front & rear	60 kPa (0.6 kp/cm ² /8.5 PSI)
Max. gradient	15°

Rider 155

Engine

Manufacture	Kohler Engines model CV15
Power	11.4/15.5 kW/h.p.
Displacement	426 cm ³ /26 cuin
Fuel	Min. 87 octane unleaded (Research min 90 octane) (Gasohol < 10% etyl alcohol or MTBE < 15% by volume)
Tank volume	7 litres/7.4 USqt
Oil	SAE 10W/30 (SAE 5W/30 below freezing point) class SG or SH
Oil volume	1.9 litres/1.8 USqt
Start	Electric starter

Noise emissions and cutting width

Measured noise level	100 dB(A)
Guaranteed noise level	100 dB(A)
Cutting width	1030 mm/41"

Electrical system

Type	12 V, negative ground
Battery	12 V 24 Ah, maintenance free
Spark plug	Champion RC12YC electrode gap = 1.02 mm/0.040"

Transmission

Manufacture	Tuff Torq K46
Oil	SAE 10W/30, class SF-CC

Cutting unit

Type	3-blade unit with Combi function
Cutting width	1030 mm/41"
Cutting heights	9 positions, 45-95 mm/1 3/4"-3 3/4"
Blade diameter	410 mm/16 1/4"

When this product is worn out or no longer used it should be returned to the dealer or other appropriate body for recycling.

We reserve the right to change technical specifications without prior notice.

Note that no legal claims are valid on the basis of information in this manual.

Use only genuine parts for repairs. The warranty is not valid if non genuine parts are used.

114 01 35-95



2002W39