

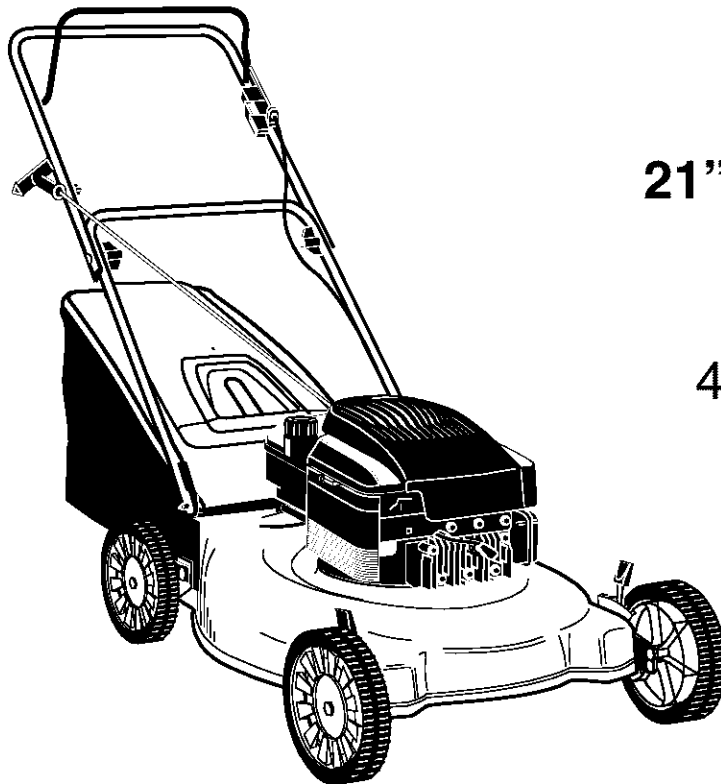

# Operator's Manual



## 21" Rear Discharge Push Mower

Model Series  
410 through 429

**IMPORTANT:** Read safety rules and instructions carefully before operating equipment.

**Warning:** This unit is equipped with an internal combustion engine and should not be used on or near any unimproved forest-covered, brush-covered or grass-covered land unless the engine's exhaust system is equipped with a spark arrester meeting applicable local or state laws (if any). If a spark arrester is used, it should be maintained in effective working order by the operator. In the State of California the above is required by law (Section 4442 of the California Public Resources Code). Other states may have similar laws. Federal laws apply on federal lands. A spark arrester for the muffler is available through your nearest engine authorized service dealer or contact the service department, P.O. Box 368022 Cleveland, Ohio 44136-9722.

**MTD PRODUCTS INC. P.O. BOX 368022 CLEVELAND, OHIO 44136-9722**

PRINTED IN U.S.A.

FORM NO. 770-10110A  
(9/99)

## TABLE OF CONTENTS

Content	Page
Important Safe Operation Practices .....	3
Slope Gauge .....	6
Assembling Your Lawn Mower.....	7
Know Your Lawn Mower .....	10
Operating Your Lawn Mower .....	11
Making Adjustments .....	12
Maintaining Your Lawn Mower.....	14
Off-Season Storage .....	15
Troubleshooting.....	16
Shroud Chart .....	17
Parts List.....	18

## FINDING MODEL NUMBER

This Operator's Manual is an important part of your new lawn mower. It will help you assemble, prepare and maintain the unit for best performance. Please read and understand what it says.



**Before you start assembling your new equipment**, please locate the model plate on the equipment and copy the information from it in the space provided below. The information on the model plate is very important if you need help from our Customer Support Department or an authorized dealer.

- You can locate the model number by standing at the operating position and looking down at the rear of the deck. A sample model plate is explained below. For future reference, please copy the model number and the serial number of the equipment in the space below.

_____	_____
(Model Number)	(Serial Number)
	
MTD PRODUCTS INC CLEVELAND, OHIO 44136	

Copy the model number here: \_\_\_\_\_

Copy the serial number here: \_\_\_\_\_

## CALLING CUSTOMER SUPPORT

If you have difficulty assembling this product or have any questions regarding the controls, operation or maintenance of this unit, please call the Customer Support Department.



Call **1- (330) 220-4MTD (4683)** or **1- (800)-800-7310** to reach a Customer Support representative. Please have your unit's model number and serial number ready when you call. See previous section to locate this information. You will be asked to enter the serial number in order to process your call .

---

## SECTION 1: IMPORTANT SAFE OPERATION PRACTICES



This symbol points out important safety instructions which, if not followed, could endanger the personal safety and/or property of yourself and others. Read and follow all instructions in this manual before attempting to operate your lawn mower. Failure to comply with these instructions may result in personal injury. When you see this symbol, heed its warning.

**DANGER:** Your lawn mower was built to be operated according to the rules for safe operation in this manual. As with any type of power equipment, carelessness or error on the part of the operator can result in serious injury. This lawn mower is capable of amputating hands and feet and throwing objects. Failure to observe the following safety instructions could result in serious injury or death.



**WARNING:** The Engine Exhaust from this product contains chemicals known to the State of California to cause cancer, birth defects or other reproductive harm.

### General Operation

- Read this operator's manual carefully in its entirety before attempting to assemble this machine. Read, understand, and follow all instructions on the machine and in the manual(s) before operation. Be completely familiar with the controls and the proper use of this machine before operating it. Keep this manual in a safe place for future and regular reference and for ordering replacement parts.
- Your rotary mower is a precision piece of power equipment, not a plaything. Therefore, exercise extreme caution at all times. Your unit has been designed to perform one job: to mow grass. Do not use it for any other purpose.
- Never allow children under 14 years old to operate a power mower. Children 14 years old and over should only operate mower under close parental supervision. Only responsible individuals who are familiar with these rules of safe operation should be allowed to use your mower.
- Keep the area of operation clear of all persons, particularly small children and pets. Stop engine when they are in the vicinity of your mower to help prevent blade contact or thrown object injury. Although the area of operation should be completely cleared of foreign objects, an object may have been overlooked and could be accidentally thrown by the mower in any direction and cause serious personal injury to the operator or any others allowed in the area.
- Wear sturdy, rough-soled work shoes and close-fitting slacks and shirts. Shirts and pants that cover the arms and legs and steel-toed shoes are recommended. Do not wear loose fitting clothes or jewelry. They can be caught in moving parts. Never operate a unit in bare feet, sandals, slippery or light weight (e.g. canvas) shoes.
- Always wear safety glasses or safety goggles during operation or while performing an adjustment or repair, to protect eyes from foreign objects that may be thrown from the machine in any direction.
- Thoroughly inspect the area where the equipment is to be used. Remove all stones, sticks, wire, bones, toys and other foreign objects which could be picked up and thrown by the mower in any direction and cause serious personal injury to the operator or any others allowed in the area. Plan your mowing pattern to avoid discharge of material toward roads, sidewalks, bystanders and the like. To help avoid a thrown objects injury, keep children, bystanders and helpers at least 75 feet from the mower while it is in operation.
- Do not put hands or feet near or under rotating parts. Keep clear of discharge opening at all times as the rotating blade can cause injury.
- Many injuries occur as a result of the mower being pulled over the foot during a fall. Do not hang on to the mower if you are falling; release the handle immediately.
- Never pull the mower toward you while you are walking. If you must back the mower away from a wall or obstruction first look down and behind, and then follow these steps:
  - a. Step back from the mower to fully extend your arms.
  - b. Be sure you are well balanced with sure footing.
  - c. Pull the mower back slowly, no more than half way toward you.
  - d. Repeat these steps as needed.
- Do not operate the mower while under the influence of alcohol or drugs.
- Do not engage the self-propelled mechanism on units so equipped while starting engine.
- The blade control handle is a safety device. Never attempt to bypass its operation. Doing so makes the safety device inoperative and may result in personal injury through contact with the rotating blade. The blade control handle must operate easily in both directions and automatically return to the disengaged position when released.
- Never operate the mower in wet grass. Always be sure of your footing. A slip and fall can cause

serious personal injury. Keep a firm hold on the handle and walk, never run. If you feel you are losing your footing, **RELEASE THE BLADE CONTROL HANDLE IMMEDIATELY** and the blade will stop rotating within three seconds.

- Mow only in daylight or good artificial light.
- Stop the blade when crossing gravel drives, walks or roads.
- If the equipment should start to vibrate abnormally, stop the engine and check immediately for the cause. Vibration is generally a warning of trouble.
- Shut the engine off and wait until the blade comes to a complete stop before removing the grass catcher or unclogging the chute. The cutting blade continues to rotate for a few seconds after the engine is shut off. Never place any part of the body in the blade area until you are sure the blade has stopped rotating.
- Never operate mower without proper guards, grass catcher, plates or other safety protective devices in place.
- Muffler and engine become hot and can cause a burn. Do not touch.
- Only use accessories approved for this machine by the manufacturer. Read, understand, and follow all instructions provided with the approved accessory.
- If situations occur which are not covered in this manual, use care and good judgment. Contact your dealer for assistance. Telephone 1-800-800-7310 for the name of your nearest dealer.
- Do not adjust the throttle control while the engine is still running.

## Slope Operation

- For your safety, use the slope gauge included as part of this manual to measure slopes before operating this unit on a sloped or hilly area. If the slope is greater than 15 degrees as shown on the slope gauge, do not operate this unit on that area or serious injury could result.

### Do:

- Mow across the face of slopes; never up and down. Exercise extreme caution when changing direction on slopes.
- Watch for holes, ruts, hidden objects, or bumps. Tall grass can hide obstacles.
- Always be sure of your footing. A slip and fall can cause serious personal injury. If you feel you are losing your balance release the blade control handle immediately and the blade will stop in less than 3 seconds.

### Do Not:

- Do not mow near drop-offs, ditches or embankments. The operator could lose footing or balance.
- Do not mow slopes greater than 15 degrees as shown on the slope gauge.

- Do not mow on wet grass. Reduced footing could cause slipping.

## Children

- Tragic accidents can occur if the operator is not alert to the presence of children. Children are often attracted to the mower and the mowing activity. Never assume that children will remain where you last saw them.
- Keep children out of the mowing area and under the watchful care of a responsible adult other than the operator.
- Be alert and turn mower off if a child enters the area.
- Before and while moving backwards, look behind and down for small children or other objects.
- Never allow children under age 14 to operate the mower. Children 14 years of age and above should read and understand the operation instructions and safety rules in this manual.
- Use extreme care when approaching blind corners, shrubs, trees, or other objects that may obscure your vision of a child or hazard.

## Service

- Use extreme care in handling gasoline and other fuels. They are extremely flammable and the vapors are explosive.
- Use only an approved gasoline container.
- Never remove gas cap or add fuel while the engine is running. Allow engine to cool at least two minutes before refueling.
- Replace gasoline cap securely and wipe off any spilled gasoline before starting the engine as it may cause a fire or explosion.
- Extinguish all cigarettes, cigars, pipes and other sources of ignition.
- Never refuel machine indoors because flammable vapors will accumulate in the area.
- Never store the machine or fuel container inside where there is an open flame or spark such as a gas water heater, space heater, or furnace.
- Never run an engine inside a closed area.
- To reduce fire hazard, keep mower free of grass, leaves, or other debris build-up. Clean up oil or fuel spillage. Allow mower to cool at least 5 minutes before storing.
- Before cleaning, repairing, or inspecting, make certain the blade and all moving parts have stopped. Disconnect the spark plug wire, and keep the wire away from the spark plug to prevent accidental starting.
- Check the blade and engine mounting bolts at frequent intervals for proper tightness. Also, visually inspect blade for damage (e.g., bent, cracked or worn). Replace with blade which meets original equipment specifications listed in this manual.

- Keep all nuts, bolts, and screws tight to be sure the equipment is in safe working condition.
- Never tamper with safety devices. Check their proper operation regularly.
- After striking a foreign object, stop the engine, remove the wire from the spark plug, and thoroughly inspect the mower for any damage. Repair the damage before starting and operating the mower.
- Never attempt to make a wheel or cutting height adjustment while the engine is running.
- Grass catcher components are subject to wear, damage and deterioration, which could expose

moving parts or allow objects to be thrown. For safety protection, frequently check components and replace with manufacturer's recommended parts, when necessary.

- Mower blades are sharp and can cut. Wrap the blade(s) or wear gloves, and use extra caution when servicing them.
- Do not change the engine governor setting or overspeed the engine. Excessive engine speeds are dangerous.
- Restrict the use of this power machine to persons who read, understand and follow the warnings and instructions in this manual and on the machine.

**SECTION 2: SLOPE GAUGE**

USE THIS PAGE AS A GUIDE TO DETERMINE SLOPES WHERE YOU MAY NOT OPERATE SAFELY.

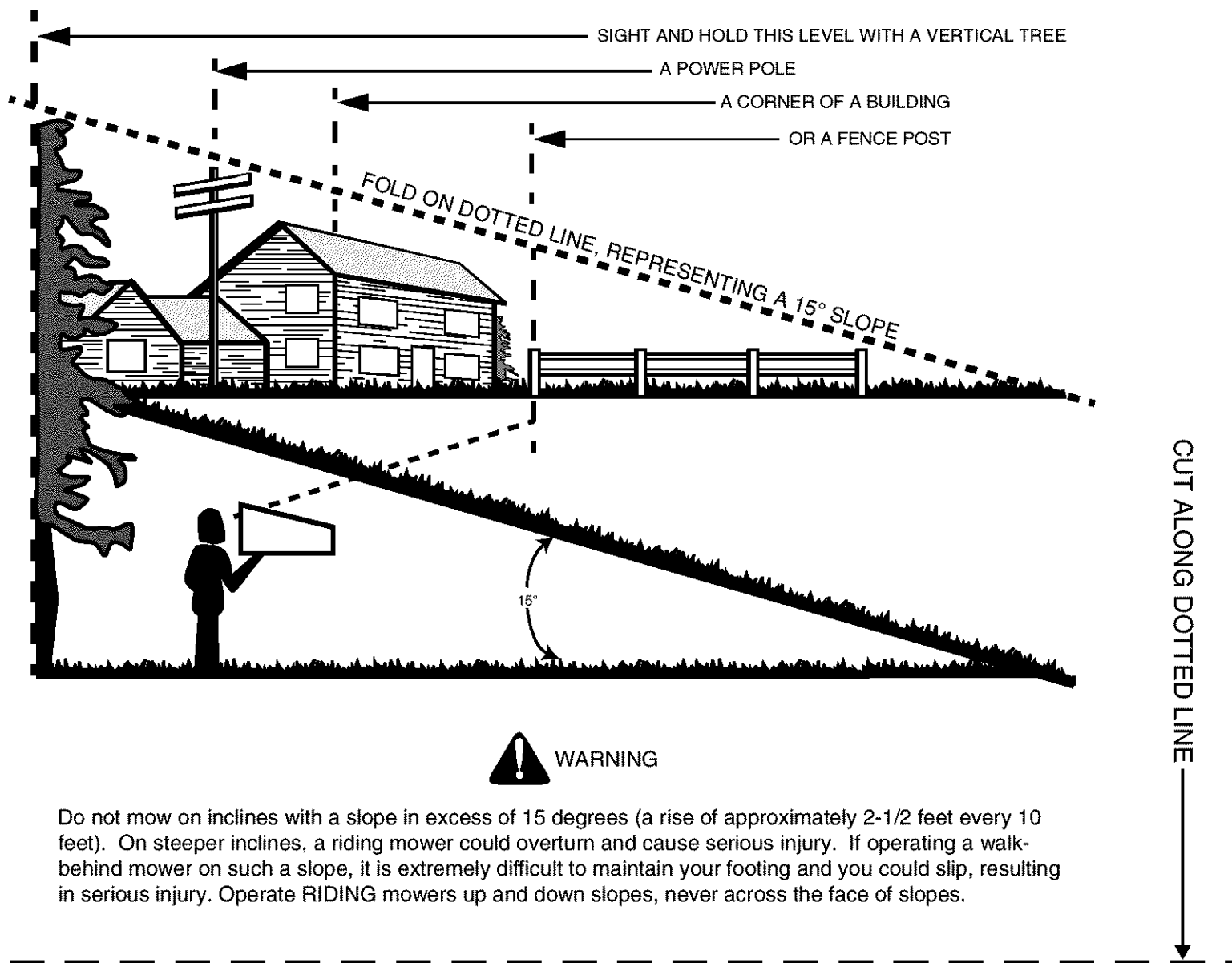

9

 **WARNING**

Do not mow on inclines with a slope in excess of 15 degrees (a rise of approximately 2-1/2 feet every 10 feet). On steeper inclines, a riding mower could overturn and cause serious injury. If operating a walk-behind mower on such a slope, it is extremely difficult to maintain your footing and you could slip, resulting in serious injury. Operate RIDING mowers up and down slopes, never across the face of slopes.

## SECTION 3: ASSEMBLING YOUR LAWN MOWER

### Unpacking

- Remove staples, break glue on top flaps, or cut tape at carton end and peel along top flap to open carton.
- Remove loose parts if included with unit (i.e., owner's manual, etc.).
- Cut along corners and lay carton down flat.
- Remove packing material.
- Roll or slide unit out of carton. Check carton thoroughly for loose parts.

### Tools Required

1. Pair of Pliers
  2. Phillips Screwdriver †
  3. 7/16" or Adjustable Wrench †
- † Hardtop grass bags only

**NOTE:** This operator's manual covers various models of lawn mowers. Follow only those instructions which pertain to your unit.

### Disconnect Spark Plug Wire

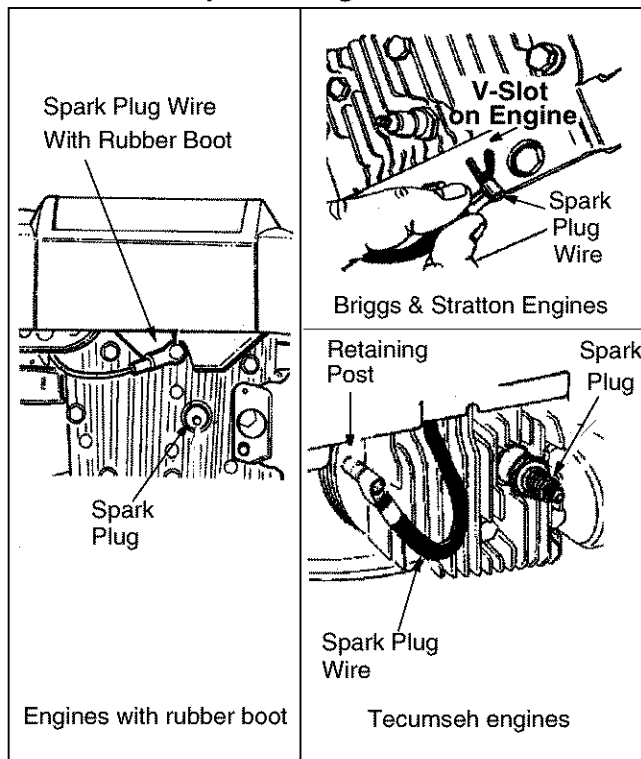

Figure 1

- Before setting up your lawn mower, disconnect the spark plug wire from the spark plug, and ground it against the engine. See Figure 1 .

- In the case of lawn mowers where engine is equipped with a rubber boot, attach rubber boot to a bolt on the engine to ground. See Figure 1.

### Assembling Handle

**NOTE:** Reference to right or left hand side of the mower is observed from the operating position.

- Remove any packing material which may be between the upper and lower handles for shipping purposes.
- Pull up and back on the upper handle to raise the handle into the operating position. Make certain the lower handle is seated securely into the handle mounting brackets.

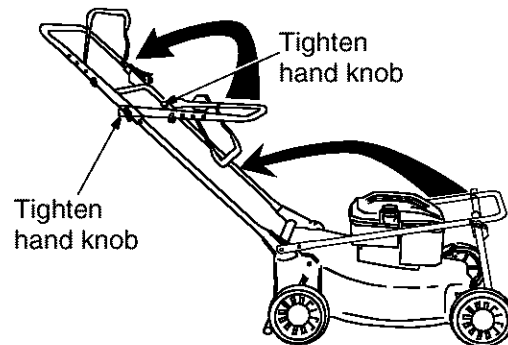

Figure 2

- Tighten the hand knobs on each side of the handle (carriage bolts must be seated properly into the handle). See Figure 2.

**NOTE:** Your mower is shipped with the handle in the higher height position. If you wish to lower the height of the handle, refer to the Adjustment Section at this time.

- Using a pair of pliers, squeeze one leg of the lower handle against the handle mounting bracket. Remove the hairpin clips from the outer hole in the weld pins on the handle mounting brackets. Insert the hairpin clip into the inner hole on the weld pin. See Figure 3. Repeat on other side.

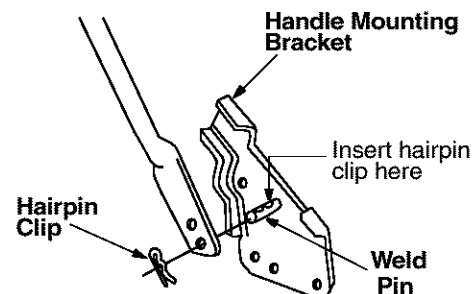

Figure 3

- The rope guide is attached to the right side of upper handle. Loosen the wing nut which secures the rope guide.
- With the spark plug wire disconnected and grounded, hold the blade control handle against the upper handle, and pull the starter rope out of the engine. Release the blade control handle. Slip the starter rope into the rope guide. Tighten the wing nut. See Figure 4.
- Make certain all nuts and bolts are tightened securely.

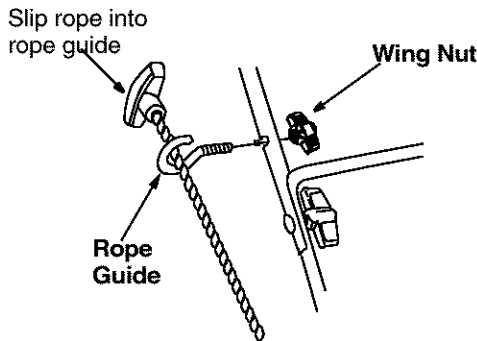

Figure 4

## Assembling Grass Catcher

**NOTE:** Make certain bag is turned right side out before assembling (warning label will be on the outside).

### A. Soft Grass Bag

Parts for Soft Grass Bag:

1. Front Frame
2. Rear Frame
3. Bag

Assemble soft grass bag as follows:

- Join the rear frame and front frame assembly as shown in Figure 5A.
- Place bag over frame (black plastic side is the bottom of bag). Slip the openings in the side of the plastic channel on bag over the hooks on the grass catcher frame.
- Secure bag to frame by working the plastic channels on bag over frame as shown in Figure 5B. All of the plastic channels except center top of bag attach from the outside of bag. Center top of bag attaches from the inside of bag.

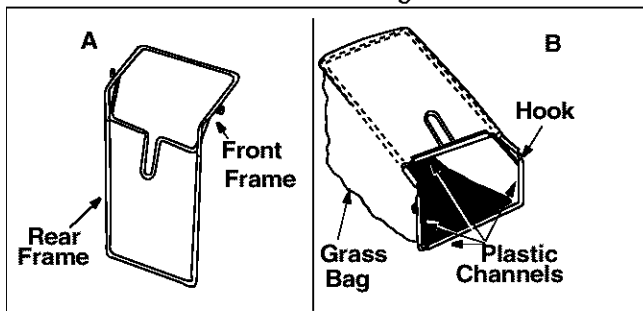

Figure 5

### B. Hardtop Grass Bag

Parts for Hardtop Grass Bag:

1. Front Frame
2. Rear Frame (packed inside hardtop cover)
3. Bag
4. Hardtop Cover
5. Mounting Bracket
6. Phillips Screw
7. Hex Lock Nut

Assemble hardtop grass bag as follows:

- Insert one end of the rear frame into the slit in the cloth channel on the edge of the grass bag (slits are approximately 6 inches from the end of the bag). See Figure 6A. Feed all the material on one side of the frame before working it around frame. Make certain the other end of rear frame comes out of the slit in the other side. See Figure 6B.

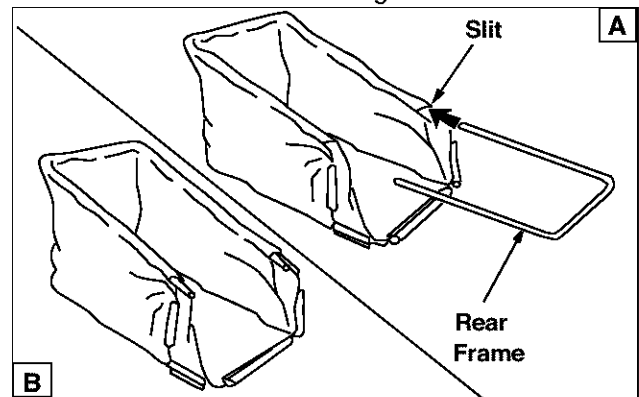

Figure 6

- Slide the front frame assembly into the rear frame as shown in Figure 7. Push the front frame in so that the cross piece on the front frame contacts the rear frame.

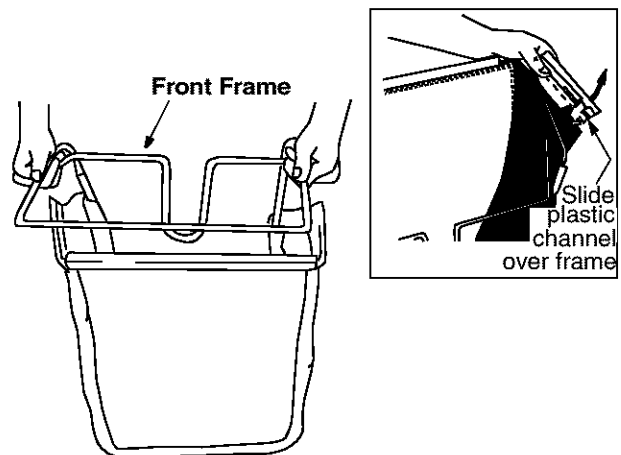

Figure 7

- Slip the openings of the plastic channel on bag over the grass catcher frame. See Figure 7 inset. Secure front of bag to front frame by working the five plastic channels on bottom, sides and top of bag over frame.



- Hold the bag and frame so the bag hangs from the frame (is not bunched around the frame). Slide the handle of the grass catcher frame through the slot in the hardtop cover as shown in Figure 8.

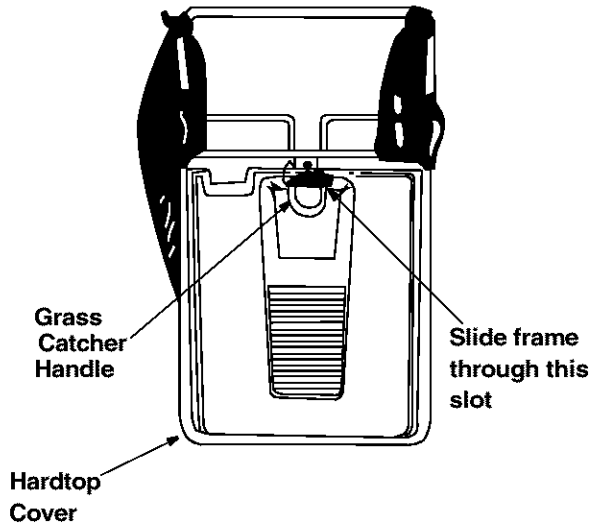

Figure 8

- Press the rear frame into the two tabs at the back of the hardtop cover and the cross bar on the front frame into the channel on the front of the hardtop cover.

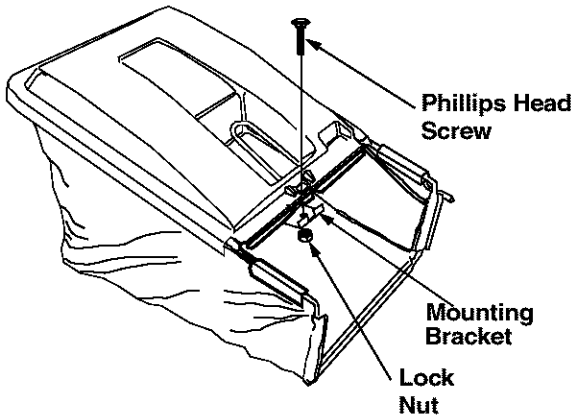

Figure 9

- Place the mounting bracket under the front of the handle, with the tabs on the bracket facing up. Insert phillips head screw down through the hardtop cover and mounting bracket. Secure with hex lock nut. See Figure 9.

## Attaching Grass Catcher To Mower

**NOTE:** Make certain cables are routed to the outside of the handle so they are not in the way when attaching the grass catcher.

- If your mower is equipped with a mulching baffle, it is in place on the mower. To remove the mulching

baffle, lift the rear discharge door on the mower. Remove the mulching baffle. See Figure 10 inset.

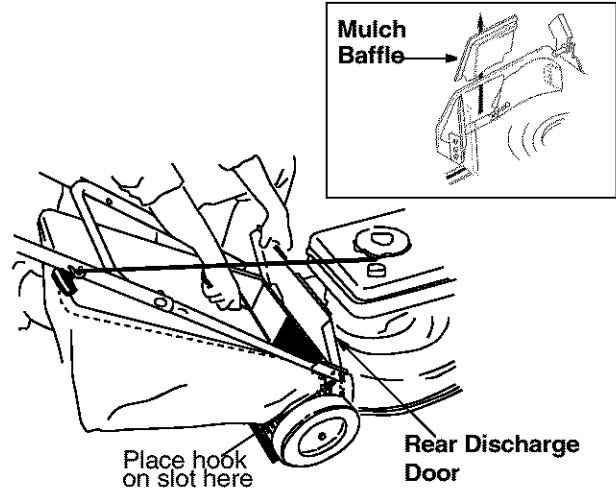

Figure 10

- **To attach the grass catcher:** Lift the rear discharge door on the mower. Place the hooks on the grass catcher into the slots in the handle bracket assemblies. Release the rear discharge door. See Figure 10.
- **To remove the grass catcher:** Lift the rear discharge door on the mower as shown in Figure 10. Lift the grass catcher up, out of the slots in the handle bracket assemblies. Release the rear discharge door.



**WARNING:** Never operate the mower unless the hooks on the grass catcher are firmly seated in the slots on the handle bracket assemblies, and the rear discharge door rests firmly against the top of the grass catcher.

## Assembling Chute Deflector

(Optional equipment)

If your mower is equipped with the optional chute deflector, assemble as follows.

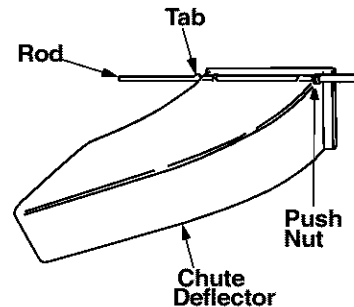

Figure 11

- Slide the rod into the upper edge of the chute deflector so the tab on the rod is toward the left side of the chute deflector. When assembled correctly,

the rod will extend further to the left side. See Figure 11.

- Slide the push nut onto the right side of the rod to secure.

## Attaching Chute Deflector To Mower

- **To attach chute deflector:** Lift the rear discharge door on the mower. Place the ends of the rod into the slots in the handle bracket assemblies. See Figure 12. Release the rear discharge door.
- **To remove chute deflector:** Lift the rear discharge door on the mower. Lift the chute deflector up and out of the slots in the handle bracket assemblies. Release the rear discharge door. See Figure 12.

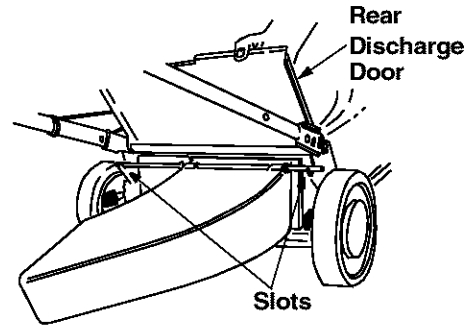

Figure 12

**IMPORTANT:** This unit is shipped without gasoline or oil in the engine. Be certain to service engine with gasoline and oil before operating your mower.

## SECTION 4: KNOW YOUR LAWN MOWER

Compare the illustrations in Figure 13 with your lawn mower to familiarize yourself with the location of various controls and adjustments. The operation of any lawn mower can result in foreign objects being thrown into the operator's eyes, causing severe eye damage. Always wear safety glasses while operating the mower, or while performing any adjustments or repairs on it.

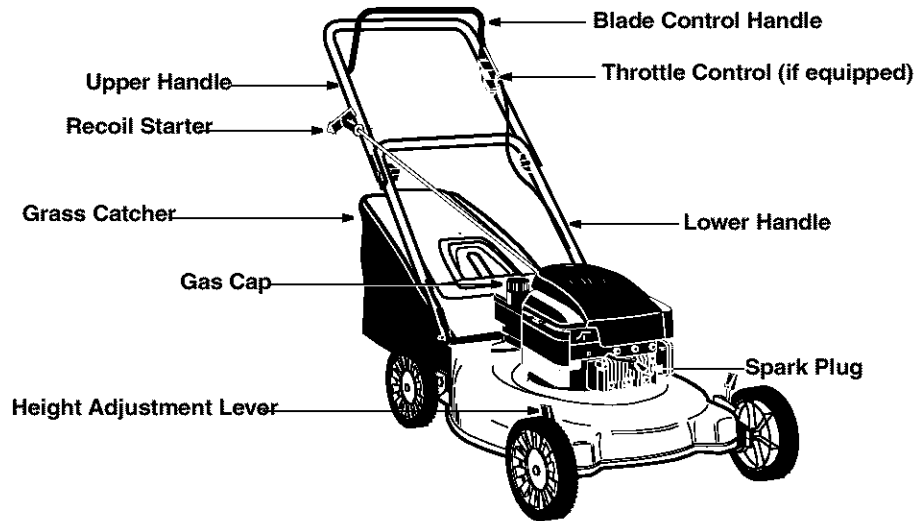

Figure 13

### Blade Control Handle



**WARNING:** This control mechanism is a safety device. Never attempt to bypass its operations.

The blade will be rotating whenever the engine is running. Keep your hands and feet away from a rotating blade.

The blade control handle is located on the upper handle of the mower. The blade control handle must be depressed in order to operate the unit. Release the blade control handle to stop the engine and blade.

### Throttle Control

Your lawn mower may be equipped with one of three types of throttle controls described below. Follow instructions which pertain to your unit.

1. The throttle control is located on the left side of the upper handle. It is used to regulate engine speed.
2. The throttle control is located on the engine. It is used to regulate the engine speed.
3. Your mower engine is equipped with a constant speed throttle, which is set at full throttle for best performance.



**WARNING:** The throttle control cannot be used to stop the engine. If your mower's throttle control is located on the engine, do not adjust the throttle control while the engine is running.

### Recoil Starter

The recoil starter handle is attached to the handle and is used to start the engine.

### Height Adjustment Lever

The height adjustment lever is located on each wheel and adjusts the cutting height. All four levers have to be put at the same level for uniform cutting height.

---

## SECTION 5: OPERATING YOUR LAWN MOWER



**WARNING:** Keep hands and feet away from the chute area on cutting deck. Refer to warning label on the unit.

The operation of any lawn mower can result in foreign objects being thrown into the eyes, which can result in severe eye damage. Always wear safety glasses or eye shields. We recommend wide vision safety mask for over spectacles or standard safety glasses.

### Gas And Oil Fill-Up

- Service the engine with gasoline and oil as instructed in the separate engine manual packed with your mower. Read instructions carefully.



**WARNING:** Never fill fuel tank indoors, with engine running or until the engine has been allowed to cool for at least two minutes after running.

### Before Starting

- Attach spark plug wire to spark plug. If your unit is equipped with a rubber boot over the end of the spark plug wire, make certain the metal cap on the end of the spark plug wire (inside the rubber boot) is fastened securely over the metal tip on the spark plug.

### To Start Engine And Engage Blade

- If engine is equipped with a throttle control lever, move the lever all the way forward to the FAST (rabbit) position.
- If engine is equipped with a primer, prime engine as instructed in the separate engine manual packed with your unit.
- Standing behind the unit, depress the blade control handle and hold it against the upper handle.
- Grasp starter handle and pull rope out slowly until engine reaches start of compression cycle (rope will pull slightly harder at this point). Let the rope rewind slowly.

- Pull rope with a rapid, continuous, full arm stroke. Keep a firm grip on starter handle. Return it slowly to the rope guide.
- After engine starts, move throttle control lever (if so equipped) to desired engine speed. Your mower is designed to operate at full throttle. Engines with fixed throttles operate at full throttle too.

### To Stop Engine And Blade

- If engine is equipped with throttle control lever on the handle, move the lever to the SLOW position.
- Release the blade control handle to stop the engine and blade.



**WARNING:** The blade continues to rotate for a few seconds after the engine has been shut off.

- Disconnect the spark plug wire and ground it against the engine to prevent accidental starting while equipment is unattended.

**NOTE:** For shipping purposes your mower is set with the wheels in a low cutting height position. For best results, raise the cutting position until it is determined which height is best for your lawn. See cutting height adjustment section on this page.

### Using Rotary Mower



**WARNING:** Never operate your unit without either the rear deflector or entire grass catcher assembly in place.

- Be sure that lawn is clear of stones, sticks, wire, or other objects which could damage lawn mower or engine. Such objects could be accidentally thrown by the mower in any direction and cause serious personal injury to the operator and others.
- For best results, do not cut wet grass because it tends to stick to the underside of the mower, preventing proper discharge of grass clippings, and could cause you to slip and fall. New grass, thick grass or wet grass may require a narrower cut. Blade speed should be adjusted to the condition of the lawn.

- For a healthy lawn, never cut more than one-third of the total length of the grass at any one cutting. Lawn should be cut in the fall as long as there is growth.
- This mower is designed to be operated at full throttle to give you the best cut and do the most effective job of bagging the cut grass.



**WARNING:** If you strike a foreign object, stop the engine. Remove wire from spark plug, thoroughly inspect the mower for any damage, and repair the damage before restarting and operating the mower. Extensive vibration of the mower during operation is an indication of damage. The unit should be promptly inspected and repaired.

## Using Mulcher

(If equipped)

- For effective mulching, do not cut wet grass because it tends to stick to the underside of the deck, preventing proper mulching of grass clippings.
- New or thick grass may require a narrower cut. The ground speed should be adjusted to the condition of the lawn. If mowing has been delayed and the grass has been allowed to grow in excess of 4", mulching is not recommended. Mow using the grass bag to reduce the grass height to 3-1/4" maximum before mulching.

## SECTION 6: MAKING ADJUSTMENTS



**WARNING:** Do not at any time make any adjustment to lawn mower without first stopping engine and disconnecting spark plug wire.

### Cutting Height

An adjusting plate and thumb lever at each wheel position provides cutting height adjustment. Each adjusting plate has nine height positions.

- Simply depress the lever towards wheel and move it to any of the nine positions for the desired cutting height. See Figure 14. All four levers on the four wheels must be placed in the same relative position for uniform cutting height.

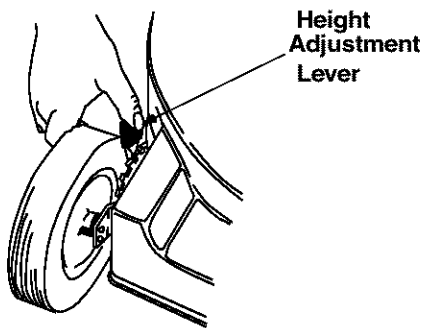

Figure 14

### Handle Height

Your mower is shipped with the handle in the higher height position. To lower the handle height, proceed as follows.

- Remove the starter rope from the rope guide.

- Remove the upper handle by removing the hand knobs and carriage bolts. Lay the upper handle out of the way, being careful not to bend or kink the cables.
- Remove the hairpin clips from the weld pins on the handle brackets. Press outward on the legs of the lower handle, and remove it from the mower.

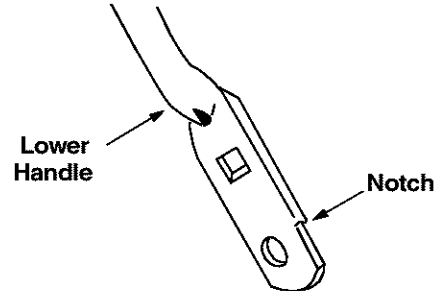

Figure 15

- Turn the lower handle around so the notches on the bottom of the lower handle are facing forward as shown in Figure 15. Reassemble, placing the bottom holes in the handle over the weld pins in the handle mounting bracket.
- Reassemble the upper handle.
- Place the hairpin clips in the inner holes in the weld pins and attach the starter rope as instructed earlier on page 7.

### Carburetor

Minor carburetor adjustments may be required to compensate for differences in fuel, temperature, altitude and load. To adjust carburetor, refer to the separate engine manual packed with your mower.

**NOTE:** A dirty air cleaner will cause an engine to run rough. Be certain air cleaner is clean and attached to the carburetor before adjusting carburetor.



**WARNING:** If any adjustments are made to the engine while the engine is running (e.g. carburetor), keep clear of all moving parts. Be careful of heated surfaces and muffler.

## Throttle Control

If your lawn mower is equipped with an adjustable throttle control on the handle (refer to the first category of throttle controls described on page 10 of this manual), adjust it following instructions below.

- Adjust the throttle control only if it is out of adjustment, or if it has been replaced.
- Remove the screw shown in Figure 16. Remove the cable clamp from the cable.

**NOTE:** If you have a Tecumseh engine, simply loosen the screw shown in Figure 16 so the cable will move freely beneath the clamp. It is not necessary to remove the screw and clamp completely.

- Push the throttle control lever on the handle all the way forward as far as it will go, then back it off **one "click."** Make certain the throttle control lever remains in this position.
- Push the control lever on the engine as far toward the **rear** of the engine as it will go. Secure the cable in this position with the cable clamp and screw.

### Briggs & Stratton Engines

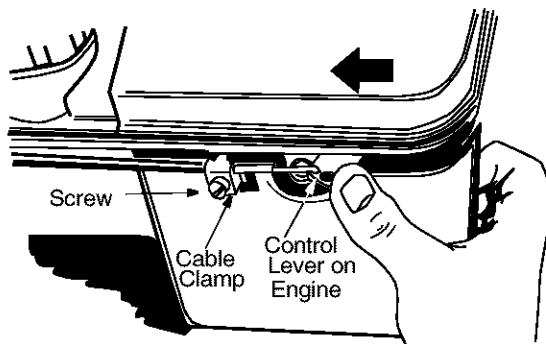

Quantum Models

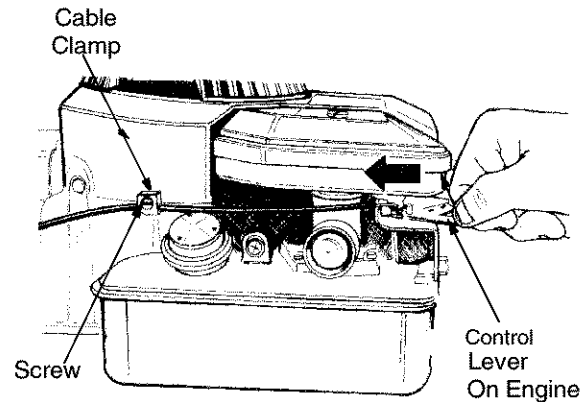

Sprint & Classic Models

### Tecumseh Engines

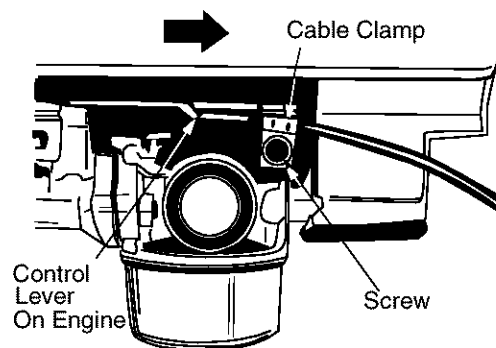

Figure 16

## SECTION 7: MAINTAINING YOUR LAWN MOWER



**WARNING:** Be sure to disconnect and ground the spark plug wire before performing any repairs or maintenance.

### Lubrication

#### Blade Control

Lubricate the pivot points on the blade control handle and the brake cable at least once a season with light oil. See Figure 17. The blade control must operate freely in both directions.

#### Rear Discharge Door

The torsion springs and pivot points should be lubricated periodically with light oil to prevent any rust or binding. Door must work freely.

#### Wheels:

The wheels require no lubrication. However, if the wheels are removed for any reason, lubricate the surface of the axle bolt and the inner surface of the wheel with light oil. Engine oil may also be used.

#### Engine

Follow engine manual for lubrication instructions.

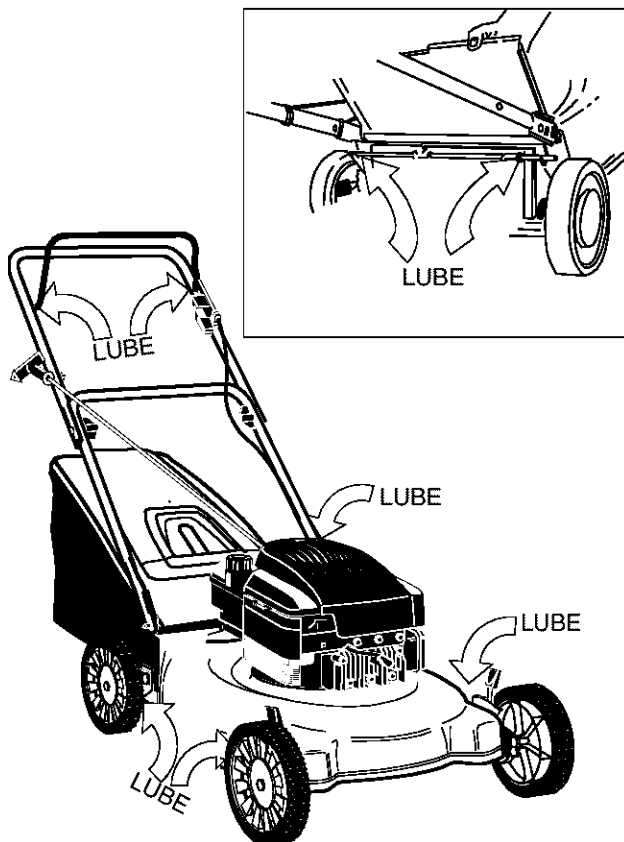

Figure 17

### Maintaining the Blade

- Periodically inspect the blade adapter for cracks, especially if you strike a foreign object. Replace when necessary.



**WARNING:** When removing the cutting blade for sharpening or replacement, protect hands by using heavy gloves or a rag to grasp the cutting blade.

- Remove the bolt and bell support which hold the blade and adapter to the engine crankshaft. See Figure 18. Remove the blade and adapter from the crankshaft.
- When sharpening the blade, follow the original angle of grind as a guide. It is extremely important that each cutting edge receive an equal amount of grinding to prevent an unbalanced blade. An unbalanced blade will cause excessive vibration when rotating at high speeds, and may cause damage to the mower and/or personal injury.
- The blade can be tested by balancing it on a round shaft screwdriver. Remove metal from the heavy side until it balances evenly. It is recommended that the blade always be removed from the adapter for the best test of balance.
- Before reassembling the blade and the blade adapter to the unit, lubricate the engine crankshaft and the inner surface of the blade adapter with light oil (or engine oil). Lubricating the bolt holes, bolts and inner surface of the nuts is also recommended.

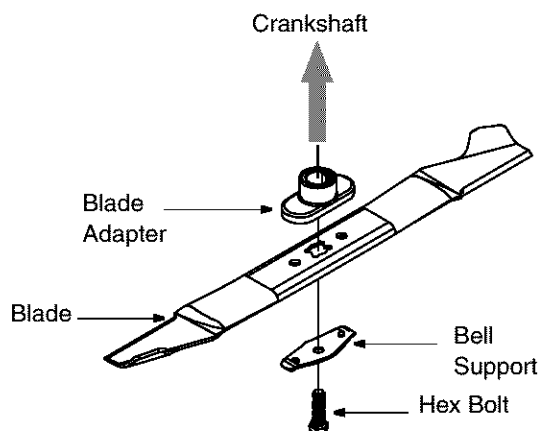

Figure 18

- Install the blade adapter on the crankshaft with the "star" away from the engine. Place the blade with the side marked bottom (or with part number) facing away from the adapter. Align the blade bell support over the blade with the tabs in the holes of the blade and insert the hex bolt. Tighten the hex bolt to the torque listed here.

### Blade Mounting Torque:

Center Bolt: 450 in. lbs. min., 600 in. lbs. max.

- To ensure safe operation of your unit, all nuts and bolts must be checked periodically for correct tightness.

## Maintaining the Deck

**NOTE:** *We do not recommend the use of pressure washers or garden hose to clean your unit. These may cause damage to electric components spindles, pulleys, bearings or the engine. The use of water will shorten life of the mower and reduce its serviceability.*

- Clean the underside of the mower deck after each use to prevent a buildup of grass clippings, leaves, dirt or other matter. If this debris is allowed to accumulate, it will result in rust and corrosion, and may cause an uneven discharge of grass clippings during the next cutting. Tilt the mower and scrape clean with a suitable tool.



**WARNING: Remember to disconnect the spark plug wire before tilting the mower.**

## Engine

Refer to the separate engine manual for engine maintenance instructions.

- Maintain engine oil level as instructed in the engine manual.

- Service air cleaner every 25 hours under normal conditions. Clean every few hours under extremely dusty conditions. Poor engine performance and flooding usually indicates that the air cleaner should be serviced. To service the air cleaner, refer to the engine manual.
- Clean spark plug and reset the gap once a season. Spark plug replacement is recommended at the start of each mowing season. Check engine manual for correct plug type and gap specifications.
- Clean engine regularly with a cloth or brush. Keep the cooling system (blower housing area) clean to permit proper air circulation which is essential to engine performance and life. Make sure to remove all grass, dirt and combustible debris from muffler area.

## Replacing Rear Flap

The rear flap is attached to the back of the mower deck, and is designed to minimize the possibility of objects being thrown from the rear of the mower toward the operator. If the rear flap becomes damaged, replace as follows:

- To remove the old rear flap, cut off the flat end of the wire rod which secures it to the deck using a pair of side-cutters. Attach the new rear flap using the new rod provided with the rear flap, bending the ends of the rod over to secure.

---

## SECTION 8: OFF-SEASON STORAGE

If the lawn mower is not going to be used for 30 days or longer, prepare the unit for storage. Follow the steps below for proper storage of the mower.

- Clean and lubricate mower thoroughly as described in the lubrication instructions.
- Refer to engine manual for correct engine storage instructions.
- Coat mower's cutting blade with chassis grease to prevent rusting.

- Store mower in a dry, clean area. Do not store next to corrosive materials, such as fertilizer.

**NOTE:** *When storing any type of power equipment in an unventilated or metal storage shed, care should be taken to rust-proof the equipment. Using a light oil or silicone, coat the equipment, especially cables and all moving parts.*

## SECTION 9: TROUBLE SHOOTING GUIDE

Trouble	Possible Cause(s)	Corrective Actions
Engine fails to start	<ol style="list-style-type: none"> <li>1. Blade control handle disengaged.</li> <li>2. Spark plug wire disconnected.</li> <li>3. Dirty aircleaner.</li> <li>4. Primer button not depressed.</li> <li>5. Throttle control lever (if so equipped) not in correct starting position .</li> <li>6. Fuel tank empty or stale fuel.</li> <li>7. Blocked fuel line</li> <li>8. Faulty spark plug.</li> <li>9. Engine flooded.</li> </ol>	<ol style="list-style-type: none"> <li>1. Engage blade control handle.</li> <li>2. Connect wire to spark plug.</li> <li>3. Refer to the engine manual packed with your unit.</li> <li>4. Refer to the engine manual packed with your unit.</li> <li>5. Move throttle lever to FAST or START position.</li> <li>6. Fill tank with clean fresh gasoline. Fuel will not last over thirty days unless a fuel stabilizer is used.</li> <li>7. Clean fuel line.</li> <li>8. Clean, adjust gap or replace.</li> <li>9. Refer to the engine manual packed with your unit.</li> </ol>
Engine runs erratic	<ol style="list-style-type: none"> <li>1. Unit running in START position.</li> <li>2. Spark plug wire loose.</li> <li>3. Blocked fuel line (if so equipped) or stale fuel.</li> <li>4. Vent in gas cap plugged.</li> <li>5. Water or dirt in fuel system.</li> <li>6. Dirty air cleaner.</li> <li>7. Carburetor out of adjustment.</li> </ol>	<ol style="list-style-type: none"> <li>1. Move throttle lever to FAST position.</li> <li>2. Connect and tighten spark plug wire. Check spark plug for fouling.</li> <li>3. Clean fuel line; fill tank with clean, fresh gasoline. Fuel will not last over thirty days unless a fuel stabilizer is added.</li> <li>4. Clear vent or threads or replace.</li> <li>5. Drain fuel tank. Refill with fresh fuel.</li> <li>6. Refer to the engine manual packed with your unit.</li> <li>7. Refer to the engine manual packed with your unit.</li> </ol>
Engine overheats	<ol style="list-style-type: none"> <li>1. Engine oil level low.</li> <li>2. Dirty aircleaner.</li> <li>3. Air flow restricted.</li> <li>4. Carburetor not adjusted properly.</li> </ol>	<ol style="list-style-type: none"> <li>1. Fill crankcase with proper oil.</li> <li>2. Refer to the engine manual packed with your unit.</li> <li>3. Stop engine and disconnect spark plug wire. Remove blower housing and clean.</li> <li>4. Refer to the engine manual packed with your unit or see an authorized service dealer.</li> </ol>
Occasional skip (hesitates) at high speed	<ol style="list-style-type: none"> <li>1. Spark plug gap too close.</li> <li>2. Carburetor idle mixture adjustment improperly set.</li> </ol>	<ol style="list-style-type: none"> <li>1. Adjust gap to .030".</li> <li>2. Refer to the engine manual packed with your unit.</li> </ol>
Idles poorly	<ol style="list-style-type: none"> <li>1. Spark plug fouled, faulty or gap too wide.</li> <li>2. Carburetor improperly adjusted.</li> <li>3. Dirty air cleaner.</li> </ol>	<ol style="list-style-type: none"> <li>1. Reset gap to .030" or replace spark plug.</li> <li>2. Refer to the engine manual packed with your unit.</li> <li>3. Refer to the engine manual packed with your unit.</li> </ol>
Excessive vibration	<ol style="list-style-type: none"> <li>1. Cutting blade loose or unbalanced.</li> <li>2. Bent cutting blade.</li> </ol>	<ol style="list-style-type: none"> <li>1. Tighten blade and adapter. Balance blade.</li> <li>2. See an authorized service dealer.</li> </ol>
Mower will not mulch grass	<ol style="list-style-type: none"> <li>1. Engine speed too low.</li> <li>2. Wet grass.</li> <li>3. Excessively high grass.</li> </ol>	<ol style="list-style-type: none"> <li>1. Set throttle between 3/4 and full throttle.</li> <li>2. Do not mow when grass is wet; wait until later to cut.</li> <li>3. Mow once at a high cutting height, then mow again at desired height or make a narrower cutting swath (1/2 width).</li> </ol>
Uneven cut	<ol style="list-style-type: none"> <li>1. Wheels not positioned correctly.</li> <li>2. Dull blade.</li> </ol>	<ol style="list-style-type: none"> <li>1. Place all four wheels in same height position.</li> <li>2. Sharpen or replace blade.</li> </ol>



**NOTE:** For repairs beyond the minor adjustments above, contact your local authorized service dealer or call Customer Service at 1(330) 220-4MTD or 1(800)800-7310.

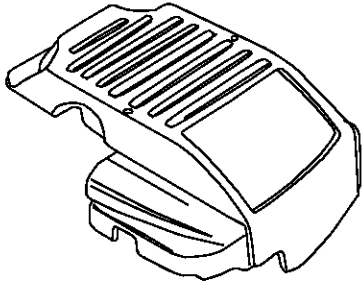
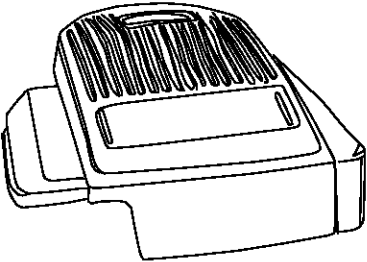
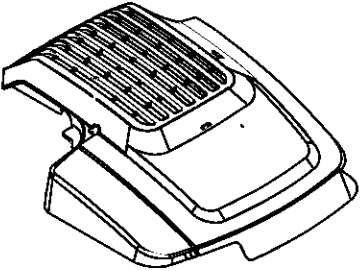
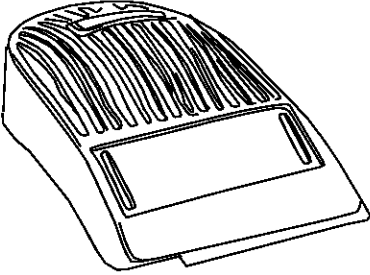
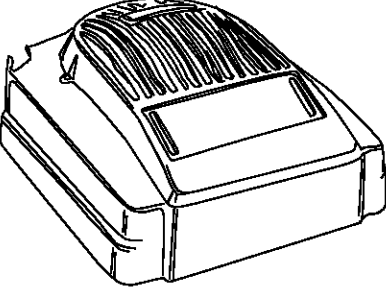
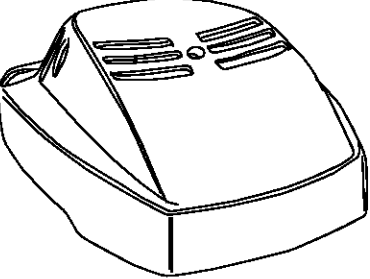
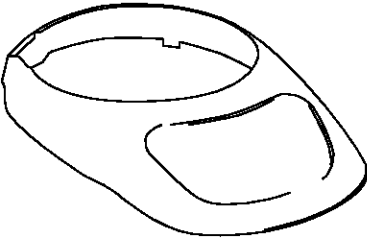
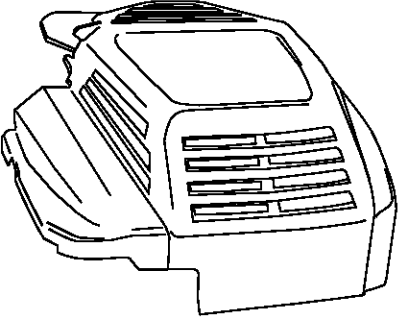
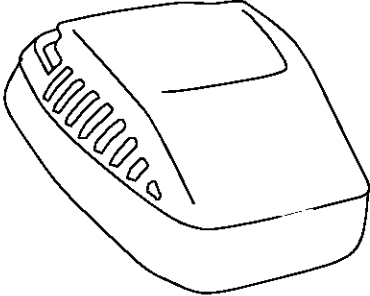

# SECTION 10: SHROUD CHART

 <table border="1" data-bbox="191 562 542 709"> <thead> <tr> <th>Shroud</th> <th>Color</th> </tr> </thead> <tbody> <tr> <td>751B281439</td> <td>Dark Red</td> </tr> <tr> <td>751B281440</td> <td>Black</td> </tr> <tr> <td>751B281443</td> <td>Bright Red</td> </tr> </tbody> </table> <p>Hardware: 710-1256</p>	Shroud	Color	751B281439	Dark Red	751B281440	Black	751B281443	Bright Red	 <table border="1" data-bbox="607 562 958 709"> <thead> <tr> <th>Shroud</th> <th>Color</th> </tr> </thead> <tbody> <tr> <td>731-1395A</td> <td>Red</td> </tr> <tr> <td>731-1396A</td> <td>Black</td> </tr> <tr> <td>731-1397A</td> <td>Grey</td> </tr> </tbody> </table> <p>Hardware: 710-1256</p>	Shroud	Color	731-1395A	Red	731-1396A	Black	731-1397A	Grey	 <table border="1" data-bbox="1052 562 1403 709"> <thead> <tr> <th>Shroud</th> <th>Color</th> </tr> </thead> <tbody> <tr> <td>731-1402A</td> <td>Yellow</td> </tr> <tr> <td>731-1694</td> <td>Black</td> </tr> <tr> <td>731-1695</td> <td>Silver</td> </tr> <tr> <td>731-1934A</td> <td>Charcoal</td> </tr> </tbody> </table> <p>Hardware: 710-1256</p>	Shroud	Color	731-1402A	Yellow	731-1694	Black	731-1695	Silver	731-1934A	Charcoal
Shroud	Color																											
751B281439	Dark Red																											
751B281440	Black																											
751B281443	Bright Red																											
Shroud	Color																											
731-1395A	Red																											
731-1396A	Black																											
731-1397A	Grey																											
Shroud	Color																											
731-1402A	Yellow																											
731-1694	Black																											
731-1695	Silver																											
731-1934A	Charcoal																											
 <table border="1" data-bbox="198 1129 542 1205"> <thead> <tr> <th>Shroud</th> <th>Color</th> </tr> </thead> <tbody> <tr> <td>731-1585B</td> <td>Black</td> </tr> </tbody> </table> <p>Hardware: 710-1274</p>	Shroud	Color	731-1585B	Black	 <table border="1" data-bbox="613 1129 958 1243"> <thead> <tr> <th>Shroud</th> <th>Color</th> </tr> </thead> <tbody> <tr> <td>731-1586B</td> <td>Black</td> </tr> <tr> <td>731-1612A</td> <td>Red</td> </tr> </tbody> </table> <p>Hardware: 7510042823</p>	Shroud	Color	731-1586B	Black	731-1612A	Red	 <table border="1" data-bbox="1052 1129 1403 1205"> <thead> <tr> <th>Shroud</th> <th>Color</th> </tr> </thead> <tbody> <tr> <td>7510143208</td> <td>Black</td> </tr> </tbody> </table> <p>Hardware: 7510042823</p>	Shroud	Color	7510143208	Black												
Shroud	Color																											
731-1585B	Black																											
Shroud	Color																											
731-1586B	Black																											
731-1612A	Red																											
Shroud	Color																											
7510143208	Black																											
 <table border="1" data-bbox="181 1667 542 1814"> <thead> <tr> <th>Shroud</th> <th>Color</th> </tr> </thead> <tbody> <tr> <td>7511681311</td> <td>Black</td> </tr> <tr> <td>7511681911</td> <td>Red</td> </tr> <tr> <td>7511682011</td> <td>Grey</td> </tr> </tbody> </table>	Shroud	Color	7511681311	Black	7511681911	Red	7511682011	Grey	 <table border="1" data-bbox="607 1667 958 1743"> <thead> <tr> <th>Shroud</th> <th>Color</th> </tr> </thead> <tbody> <tr> <td>751B281451</td> <td>Dark Red</td> </tr> </tbody> </table> <p>Hardware: 710-1256</p>	Shroud	Color	751B281451	Dark Red	 <table border="1" data-bbox="1052 1667 1403 1780"> <thead> <tr> <th>Shroud</th> <th>Color</th> </tr> </thead> <tbody> <tr> <td>751B281476</td> <td>Black</td> </tr> <tr> <td>751B281777</td> <td>Yellow</td> </tr> </tbody> </table> <p>Hardware: 710-1237</p>	Shroud	Color	751B281476	Black	751B281777	Yellow								
Shroud	Color																											
7511681311	Black																											
7511681911	Red																											
7511682011	Grey																											
Shroud	Color																											
751B281451	Dark Red																											
Shroud	Color																											
751B281476	Black																											
751B281777	Yellow																											

# SECTION 11: PARTS LIST FOR MODEL SERIES 410 THROUGH 429

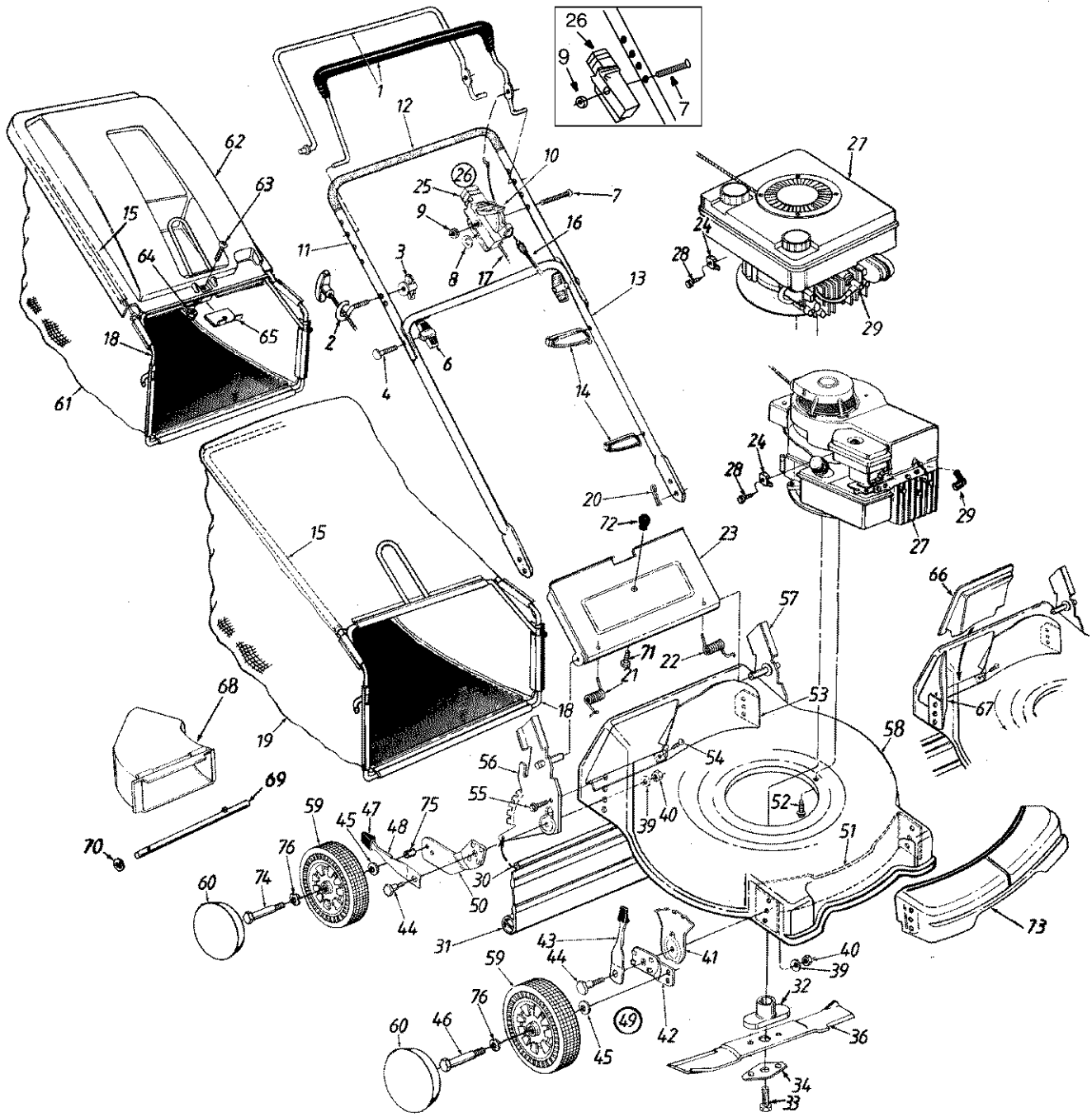

# Model Series 410 Through 429

Ref no.	Part no.	Description	Ref no.	Part no.	Description
1	747-0824	Control Handle (Std.)	39	736-0356	Bell-Wash. .39" I.D. x 1.38"
	647-0004	Control Handle Ass'y. (Deluxe)	40	712-0798	Hex Nut 3/8-16 Thd.
2	710-1205	Rope Guide	41	15261A	Height Adj. Plate
3	720-0279	Handle Knob 1/4-20 Thd.	42	15262B	Pivot Bar
4	710-1174	Curved Hd. Bolt 5/16-18 x 2" Lg	43	14832	Spring Lever Ass'y. w/Knob
6	720-0314	Hand Knob	44	738-0507B	Shld. Bolt .5" Dia. x .357"
7	710-0605	Oval C-Sunk Mach. Scr.†	45	736-0105	Bell-Wash. .38" I.D. x .88" O.D.
	710-1270	Oval C-Sunk Mach. Scr.	46	738-0102	Axle Bolt
8	736-0501	Spring Washer .66" I.D.†	47	720-0190	Spring Lever Knob
9	712-0324	Hex L-Nut 1/4-20 Thd.	48	732-0417A	Spring Lever
10	746-0876	Throttle Lever †	49	14578	Height Adj. Assembly Comp. - R.H.
11	749-0705	Upper Handle		14579	Height Adj. Assembly Comp. -L.H. (not shown)
12	720-0295	Foam Grip (Optional)			
13	749-0928	Lower Handle	50	14765	Pivot Bar R.H.
14	726-0240	Cable Tie		14766	Pivot Bar L.H. (not shown)
15	764-0310	Rear Catcher Frame	51	782-5002	Front Baffle
16	746-0550	Control Cable-39"	52	710-0654A	Hex L-Wash. Hd. Scr. 3/8-16 x 1"
	746-0555	Control Cable-55"	53	782-5003	Rear Baffle
	746-0551	Control Cable-43"	54	710-1017	Torx Mach. AB-Tap Scr. 1/4 x 62"
17	746-0843	Throttle Control Wire - 55"	55	710-0896	Wash.Scr. 1/4 -14 x .625
18	764-0311	Front Catcher Frame	56	682-0516A	Handle Bracket Assembly - R.H.
19	764-0309	Grass Bag	57	682-0515A	Handle Bracket Assembly - L.H.
	764-0476A	Grass Bag w/Logo	58	782-0310A	21" R.D. Deck
20	714-0104	Int. Cotter Pin 5/16" Dia.	59	(See Chart)	Wheel Assy. Comp.
21	732-0678	Door Spring - R.H.	60	731-0981A	Hub Cap - Gray , Rad. Spoke†
22	732-0677	Door Spring - L.H.		720-0249	Hub Cap - Gray, Euro †
23	782-7000	Rear Discharge Door	61	764-0433	Grass Bag
24	751B213146	Cable Clamp (B&S) †	62	731-1322A	Hard Top Cover
	7510007775	Casing Clamp (Tec.) †		731-1876	Hard Top Cover w/Logo
25	646-0875	Throttle Body †	63	710-0286	Pan Hd. Mach. Scr. 1/4-20 x .5" Lg.
26	811-00185	Throttle Box Comp. (Incl. Ref. 7, 8, 9, 10, 25)†	64	712-0324	Hex Nylon L-Nut 1/4-20 Thd.
	746-0883	Housing, E.R.S. w/o Throttle	65	782-9011	Mounting Bracket
27	—	Engine	66	782-5007A	Mulching Baffle Plug †
28	710-1237	Hex Wash. Hd. Scr. #10-32 x .62" Lg. (B&S) †	67	782-5004	Mulching Baffle - R.R. †
			68	731-1405	Deflector †
29	735-0639	Spark Plug Boot †	69	711-0996	Rod †
30	732-0700	Wire Rod	70	726-0201	Push Speed Nut †
31	731-1236	Rear Flap	71	710-0192	Truss Scr. #10-24 x .38" Lg.
32	753-0588	Blade Adapter Kit (Incl. Ref. 33, 34)	72	720-0275	Knob
33	710-1044	Hex Bolt 3/8-24 x 1.5" Lg.	73	731-1506	Deck: Front Cover †
34	736-0524A	Blade Bell Support	74	738-0213	Rear Axle Bolt †
36	742-0741	21" Mulching Blade	75	738-0102	Axle Bolt
	742-0641	21" Blade	76	750-0535	Spacer †
				736-0504	Wave Washer †

† If equipped

## Wheel Chart

Type of Wheel	Part No.	Tread	Color
Wheels w/o bearings	734-1781, Slot Hub	Bar Tread	Grey
Wheels w/o bearings	734-1841, Aero	Bar Tread	Grey
Wheels w/o bearings	734-1987, Spok	Bar Tread	Grey
Wheels w/o bearings	634-0020, Disc Hub	Bar Tread	Grey
Wheels w/ bearings (Bearing part no. 741-0484)	734-1819	Link Tread	Grey

# MANUFACTURER'S LIMITED WARRANTY FOR:



The limited warranty set forth below is given by MTD PRODUCTS INC ("MTD") with respect to new merchandise purchased and used in the United States, its possessions and territories.

MTD warrants this product against defects in material and workmanship for a period of two (2) years commencing on the date of original purchase and will, at its option, repair or replace, free of charge, any part found to be defective in material or workmanship. This limited warranty shall only apply if this product has been operated and maintained in accordance with the Operator's Manual furnished with the product, and has not been subject to misuse, abuse, commercial use, neglect, accident, improper maintenance, alteration, vandalism, theft, fire, water or damage because of other peril or natural disaster. Damage resulting from the installation or use of any accessory or attachment not approved by MTD Products Inc. for use with the product(s) covered by this manual will void your warranty as to any resulting damages.

Normal wear parts or components thereof are subject to separate terms as follows: All normal wear part or component failures will be covered on the product for a period of 90 days regardless of cause. After 90 days, but within the two year period, normal wear part failures will be covered ONLY IF caused by defects in material or workmanship of OTHER component parts. Normal wear parts and components include, but are not limited to, belts, blades, blade adapters, grass bags, rider deck wheels, seats, snow thrower skid shoes, shave plates and tires. Batteries are covered by a 90-day limited replacement warranty.

**HOW TO OBTAIN SERVICE:** Warranty service is available, WITH PROOF OF PURCHASE THROUGH YOUR LOCAL AUTHORIZED SERVICE DEALER. To locate the dealer in your area, please check for a listing in the Yellow Pages or contact the Customer Service Department of MTD PRODUCTS INC by calling 1-800-800-7310 or writing to P.O. Box 368022, Cleveland, Ohio 44136-9722.

**This limited warranty does not provide coverage in the following cases:**

- a. The engine or component parts thereof. These items carry a separate manufacturer's warranty. Please refer to the applicable manufacturer's warranty on these items.
- b. Log splitter pumps, valves and cylinders have a separate one year warranty.

c. Routine maintenance items such as lubricants, filters, blade sharpening and tune-ups, or adjustments such as brake adjustments, clutch adjustments or deck adjustments; and normal deterioration of the exterior finish due to use or exposure.

d. MTD does not extend any warranty for products sold or exported outside of the United States of America, its possessions and territories, except those sold through MTD's authorized channels of export distribution.

**No implied warranty, including any implied warranty of merchantability or fitness for a particular purpose, applies after the applicable period of express written warranty above as to the parts as identified. No other express warranty or guaranty, whether written or oral, except as mentioned above, given by any person or entity, including a dealer or retailer, with respect to any product shall bind MTD. During the period of the Warranty, the exclusive remedy is repair or replacement of the product as set forth above. (Some states do not allow limitations on how long an implied warranty lasts, so the above limitation may not apply to you.)**

**The provisions as set forth in this Warranty provide the sole and exclusive remedy arising from the sales. MTD shall not be liable for incidental or consequential loss or damages including, without limitation, expenses incurred for substitute or replacement lawn care services, for transportation or for related expenses, or for rental expenses to temporarily replace a warranted product. (Some states do not allow the exclusion or limitation of incidental or consequential damages, so the above exclusion or limitation may not apply to you.)**

In no event shall recovery of any kind be greater than the amount of the purchase price of the product sold. Alteration of the safety features of the product shall void this Warranty. You assume the risk and liability for loss, damage, or injury to you and your property and/or to others and their property arising out of the use or misuse or inability to use the product.

This limited warranty shall not extend to anyone other than the original purchaser, original lessee or the person for whom it was purchased as a gift.

**How State Law Relates to this Warranty:** This limited warranty gives you specific legal rights, and you may also have other rights which vary from state to state.