

Operator's Manual

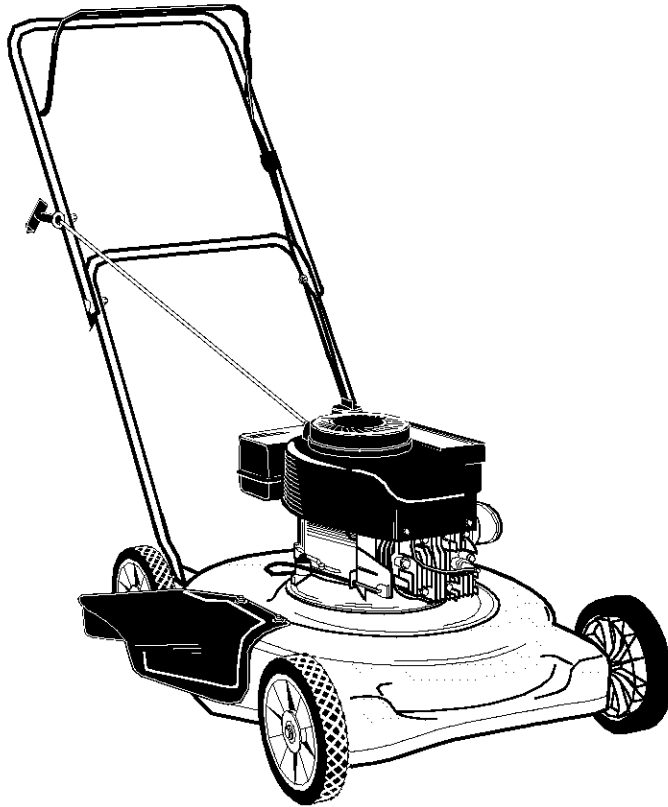

20" Rotary Lawn Mower

Model Series
020

IMPORTANT: Read safety rules and instructions carefully before operating equipment.

Warning: This unit is equipped with an internal combustion engine and should not be used on or near any unimproved forest-covered, brush-covered or grass-covered land unless the engine's exhaust system is equipped with a spark arrester meeting applicable local or state laws (if any). If a spark arrester is used, it should be maintained in effective working order by the operator. In the State of California the above is required by law (Section 4442 of the California Public Resources Code). Other states may have similar laws. Federal laws apply on federal lands. A spark arrester for the muffler is available through your nearest engine authorized service dealer or contact the service department, P.O. Box 368022 Cleveland, Ohio 44136-9722.

MTD PRODUCTS INC. P.O. BOX 368022 CLEVELAND, OHIO 44136-9722, U.S.A.

PRINTED IN U.S.A.

FORM NO. 770-10419
(4/2000)

TABLE OF CONTENTS

Content	Page
Important Safe Operation Practices.....	3
Slope Gauge.....	6
Hardware Pack	7
Assembling Your Lawn Mower.....	7
Know Your Lawn Mower	10
Operating Your Lawn Mower	10
Making Adjustments	11
Maintaining Your Lawn Mower.....	11
Off-Season Storage	13
Troubleshooting.....	13
Parts List.....	14

FINDING MODEL NUMBER

This Operator's Manual is an important part of your new lawn mower. It will help you assemble, prepare and maintain the unit for best performance. Please read and understand what it says.



Before you start assembling your new equipment, please locate the model plate on the equipment and copy the information from it in the space provided below. The information on the model plate is very important if you need help from our Customer Support Department or an authorized dealer.

- You can locate the model number by standing at the operating position and looking down at the rear of the mower deck. A sample model plate is explained below. For future reference, please copy the model number and the serial number of the equipment in the space below.



Copy the model number here: _____

Copy the serial number here: _____

CALLING CUSTOMER SUPPORT

If you have difficulty assembling this product or have any questions regarding the controls, operation or maintenance of this unit, please call the customer support department.



Call 1- (330) 220-4MTD (4683) or 1- (800)-800-7310 to reach a Customer Support representative. Please have your unit's model number and serial number ready when you call. See previous section to locate this information. You will be asked to enter the serial number in order to process your call .

For more details about proper lawn care, visit our website at www.mtdproducts.com/machines/tips

SECTION 1: IMPORTANT SAFE OPERATION PRACTICES



WARNING: This symbol points out important safety instructions which, if not followed, could endanger the personal safety and/or property of yourself and others. Read and follow all instructions in this manual before attempting to operate this machine. Failure to comply with these instructions may result in personal injury. When you see this symbol—HEED ITS WARNING.



WARNING: The Engine Exhaust from this product contains chemicals known to the State of California to cause cancer, birth defects or other reproductive harm.



DANGER: This machine was built to be operated according to the rules for safe operation in this manual. As with any type of power equipment, carelessness or error on the part of the operator can result in serious injury. This machine is capable of amputating hands and feet and throwing objects. Failure to observe the following safety instructions could result in serious injury or death.

General Operation

1. Read this operator's manual carefully in its entirety before attempting to assemble this machine. Read, understand, and follow all instructions on the machine and in the manual(s) before operation. Be completely familiar with the controls and the proper use of this machine before operating it. Keep this manual in a safe place for future and regular reference and for ordering replacement parts.
2. This machine is a precision piece of power equipment, not a plaything. Therefore, exercise extreme caution at all times. Your unit has been designed to perform one job: to mow grass. Do not use it for any other purpose.
3. Never allow children under 14 years old to operate this machine. Children 14 years old and over should read and understand the operation instructions and safety rules in this manual and should be trained and supervised by a parent. Only responsible individuals who are familiar with these rules of safe operation should be allowed to use this machine.
4. Thoroughly inspect the area where the equipment is to be used. Remove all stones, sticks, wire, bones, toys and other foreign objects which could be tripped over or picked up and thrown by the blade. Thrown objects can cause serious personal injury. Plan your mowing pattern to avoid discharge of material toward roads, sidewalks, bystanders and the like. Also, avoid discharging material against a wall or obstruction which may cause discharged material to ricochet back toward the operator.
5. To help avoid blade contact or a thrown object injury, keep children, bystanders and helpers at least 75 feet from the mower while it is in operation. Stop mower if anyone enters the area.
6. Always wear safety glasses or safety goggles during operation and while performing an adjustment or repair to protect your eyes. Thrown objects which ricochet can cause serious injury to the eyes.
7. Wear sturdy, rough-soled work shoes and close-fitting slacks and shirts. Shirts and pants that cover the arms and legs and steel-toed shoes are recommended. Never operate this machine in bare feet, sandals, slippery or light weight (e.g. canvas) shoes.
8. Do not put hands or feet near rotating parts or under the cutting deck. Contact with the blade can amputate hands and feet.
9. A missing or damaged discharge cover can cause blade contact or thrown object injuries.
10. Many injuries occur as a result of the mower being pulled over the foot during a fall caused by slipping or tripping. Do not hold on to the mower if you are falling; release the handle immediately.
11. Never pull the mower back toward you while you are walking. If you must back the mower away from a wall or obstruction first look down and behind to avoid tripping and then follow these steps:
 - a. Step back from the mower to fully extend your arms.
 - b. Be sure you are well balanced with sure footing.
 - c. Pull the mower back slowly, no more than half way toward you.
 - d. Repeat these steps as needed.
5. Do not operate the mower while under the influence of alcohol or drugs.
6. Do not engage the self-propelled mechanism on units so equipped while starting engine.
7. The blade control handle is a safety device. Never attempt to bypass its operation. Doing so makes the safety device inoperative and may result in personal injury through contact with the rotating blade. The blade control handle must operate easily in both directions and automatically return to the disengaged position when released.
8. Never operate the mower in wet grass. Always be sure of your footing. A slip and fall can cause serious personal injury. If you feel you are losing your footing, release the blade control handle immediately and the blade will stop rotating within three seconds.
9. Mow only in daylight or in good artificial light. Walk, never run.
10. Stop the blade when crossing gravel drives, walks or roads.
11. If the equipment should start to vibrate abnormally, stop the engine and check immediately for the cause. Vibration is generally a warning of trouble.
12. Shut the engine off and wait until the blade comes to a complete stop before removing the grass catcher or unclogging the chute. The cutting blade continues to rotate for a few seconds after the engine is shut off. Never place any part of the body in the blade area until you are sure the blade has stopped rotating.
13. Never operate mower without proper trail shield,

discharge cover, grass catcher, blade control handle or other safety protective devices in place and working. Never operate mower with damaged safety devices. Failure to do so, can result in personal injury.

14. Muffler and engine become hot and can cause a burn. Do not touch.
15. Only use parts and accessories made for this machine by the manufacturer. Failure to do so, can result in personal injury.
16. If situations occur which are not covered in this manual, use care and good judgment. Contact your dealer for assistance. Telephone 1-800-800-7310 for the name of your nearest dealer.

Slope Operation

Slopes are a major factor related to slip and fall accidents which can result in severe injury. Operation on slopes requires extra caution. If you feel uneasy on a slope, do not mow it. For your safety, use the slope gauge included as part of this manual to measure slopes before operating this unit on a sloped or hilly area. If the slope is greater than 15 degrees, do not mow it.

Do:

1. Mow across the face of slopes; never up and down. Exercise extreme caution when changing direction on slopes.
2. Watch for holes, ruts, rocks, hidden objects, or bumps which can cause you to slip or trip. Tall grass can hide obstacles.
3. Always be sure of your footing. A slip and fall can cause serious personal injury. If you feel you are losing your balance, release the blade control handle immediately, and the blade will stop rotating within 3 seconds.

Do Not:

1. Do not mow near drop-offs, ditches or embankments, you could lose your footing or balance.
2. Do not mow slopes greater than 15 degrees as shown on the slope gauge.
3. Do not mow on wet grass. Unstable footing could cause slipping.

Children

Tragic accidents can occur if the operator is not alert to the presence of children. Children are often attracted to the mower and the mowing activity. They do not understand the dangers. Never assume that children will remain where you last saw them.

1. Keep children out of the mowing area and under the watchful care of a responsible adult other than the operator.
2. Be alert and turn mower off if a child enters the area.
3. Before and while moving backwards, look behind and down for small children.
4. Use extreme care when approaching blind corners, doorways, shrubs, trees, or other objects that may obscure your vision of a child who may run into the mower.
5. Keep children away from hot or running engines. They can suffer burns from a hot muffler.

6. Never allow children under 14 years old to operate a power mower. Children 14 years old and over should read and understand the operation instructions and safety rules in this manual and should be trained and supervised by a parent.

Service

Safe Handling Of Gasoline:

1. To avoid personal injury or property damage use extreme care in handling gasoline. Gasoline is extremely flammable and the vapors are explosive. Serious personal injury can occur when gasoline is spilled on yourself or your clothes which can ignite.
2. Wash your skin and change clothes immediately.
3. Use only an approved gasoline container.
4. Never fill containers inside a vehicle or on a truck or trailer bed with a plastic liner. Always place containers on the ground away from your vehicle before filling.
5. When practical, remove gas-powered equipment from the truck or trailer and refuel it on the ground. If this is not possible, then refuel such equipment on a trailer with a portable container, rather than from a gasoline dispenser nozzle.
6. Keep the nozzle in contact with the rim of the fuel tank or container opening at all times until fueling is complete. Do not use a nozzle lock-open device.
7. Extinguish all cigarettes, cigars, pipes and other sources of ignition.
8. Never fuel machine indoors because flammable vapors will accumulate in the area.
9. Never remove gas cap or add fuel while the engine is hot or running. Allow engine to cool at least two minutes before refueling.
10. Never over fill fuel tank. Fill tank to no more than ½ inch below bottom of filler neck to provide space for fuel expansion.
11. Replace gasoline cap and tighten securely.
12. If gasoline is spilled, wipe it off the engine and equipment. Move unit to another area. Wait 5 minutes before starting the engine.
13. Never store the machine or fuel container inside where there is an open flame, spark or pilot light as on a water heater, space heater, furnace, clothes dryer or other gas appliances.
14. To reduce fire hazard, keep mower free of grass, leaves, or other debris build-up. Clean up oil or fuel spillage and remove any fuel soaked debris.
15. Allow a mower to cool at least 5 minutes before storing.

General Service:

1. Never run an engine indoors or in a poorly ventilated area. Engine exhaust contains carbon monoxide, an odorless and deadly gas.
2. Before cleaning, repairing, or inspecting, make certain the blade and all moving parts have stopped. Disconnect the spark plug wire and ground against the engine to prevent unintended starting.
3. Check the blade and engine mounting bolts at frequent intervals for proper tightness. Also, visually inspect blade for damage (e.g., bent, cracked, worn) Replace blade with the original equipment manufacture's (O.E.M.) blade

only, listed in this manual. "Use of parts which do not meet the original equipment specifications may lead to improper performance and compromise safety!"

4. Mower blades are sharp and can cut. Wrap the blade or wear gloves, and use extra caution when servicing them.
5. Keep all nuts, bolts, and screws tight to be sure the equipment is in safe working condition.
6. Never tamper with safety devices. Check their proper operation regularly.
7. After striking a foreign object, stop the engine, disconnect the spark plug wire and ground against the engine. Thoroughly inspect the mower for any damage. Repair the damage before starting and operating the mower.
8. Never attempt to make a wheel or cutting height adjustment while the engine is running.
9. Grass catcher components, discharge cover, and trail

shield are subject to wear and damage which could expose moving parts or allow objects to be thrown. For safety protection, frequently check components and replace immediately with original equipment manufacturer's (O.E.M.) parts only, listed in this manual. "Use of parts which do not meet the original equipment specifications may lead to improper performance and compromise safety!"

10. Do not change the engine governor setting or overspeed the engine. The governor controls the maximum safe operating speed of the engine.
11. Maintain or replace safety and instruction labels, as necessary.
12. Observe proper disposal laws and regulations. Improper disposal of fluids and materials can harm the environment.

Your Responsibility

- Restrict the use of this power machine to persons who read, understand and follow the warnings and instructions in this manual and on the machine.

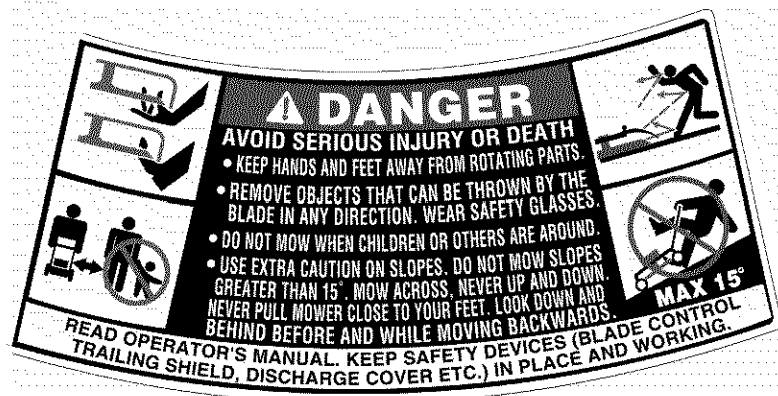

SECTION 2: SLOPE GAUGE

Use this page as a guide to determine slopes where you may not operate the lawn mower safely.

USE THIS PAGE AS A GUIDE TO DETERMINE SLOPES WHERE YOU MAY NOT OPERATE SAFELY.

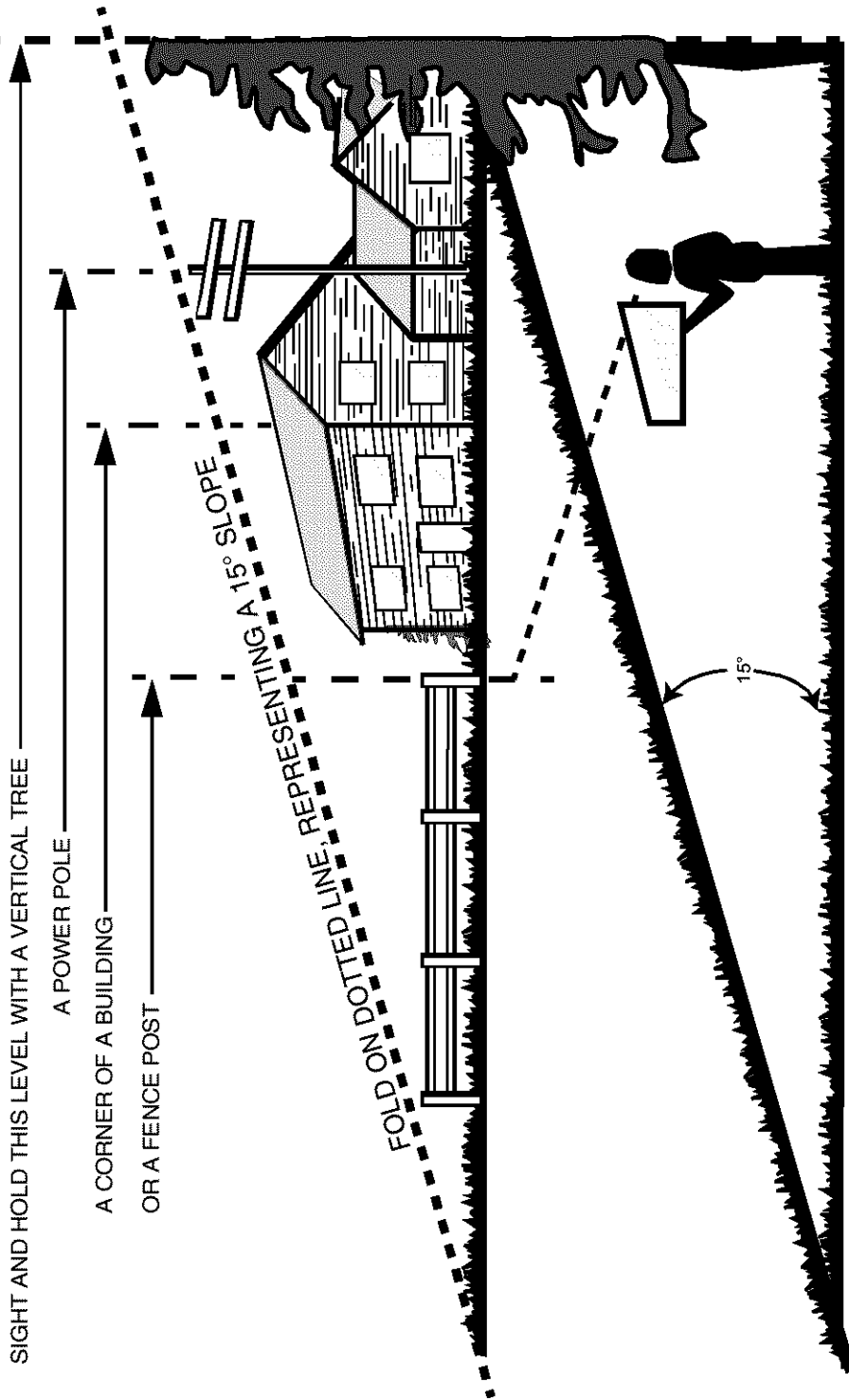

Do not mow on inclines with a slope in excess of 15 degrees (a rise of approximately 2-1/2 feet every 10 feet). A riding mower could overturn and cause serious injury. If operating a walk-behind mower on such a slope, it is extremely difficult to maintain your footing and you could slip, resulting in serious injury. Operate RIDING mowers up and down slopes, never across the face of slopes. Operate WALK-BEHIND mowers across the face of slopes, never up and down slopes.

SECTION 3: HARDWARE PACK

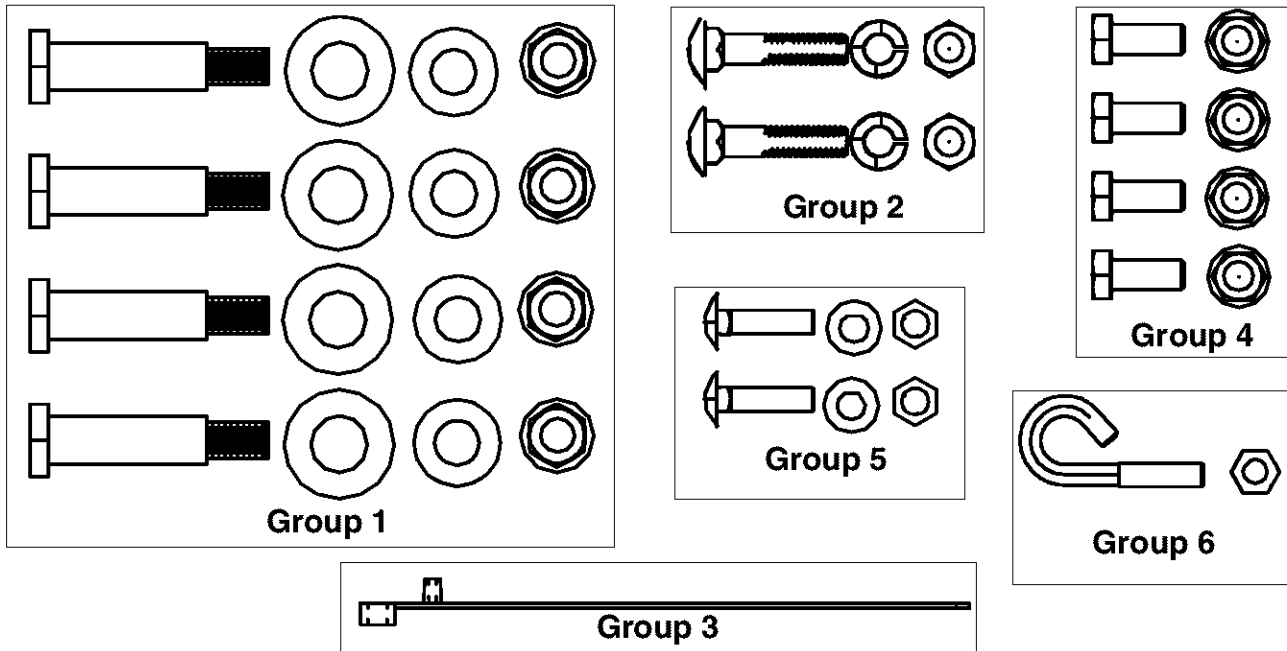

SECTION 4: ASSEMBLING YOUR LAWN MOWER

NOTE: This operator's manual covers various models of mowers. Follow only those instructions which pertain to your unit.

To Remove Unit From Carton

- Remove staples, break glue on top flaps, or cut tape at carton end and peel along top flap to open carton.
- Remove loose parts, if included with unit.
- Cut along corners and lay carton down flat.
- Remove packing material. Roll or slide unit out of carton. Check carton thoroughly for loose parts.

Tools Required

A set of adjustable wrenches or individual wrenches of the following sizes: 7/16", 1/2", 9/16", 3/4".

NOTE: Reference to right or left hand side of the mower is observed from the operating position.

Disconnect Spark Plug Wire



WARNING: Disconnect the spark plug wire and ground it against the engine to prevent unintended starting.

NOTE: On engines with a rubber boot, attach rubber boot to a bolt on the engine to ground

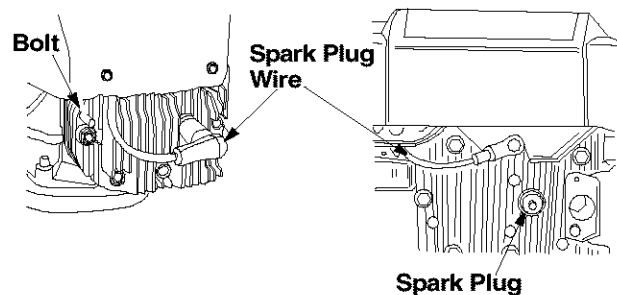

Figure 1

IMPORTANT: This unit is shipped without gasoline or oil in the engine. Do not start the engine before filling up gasoline and oil.

IMPORTANT: Before starting to assemble the unit, identify the items of the hardware pack according to the groups in Section 3 on this page. These same groups are referred to in the subsequent assembly instructions.

Attaching Lower Handle

- Lift the rear of the deck and place it on a block securely.
- Place the lower handle (pointed end will face down) over the deck and align the holes on the deck with the corresponding holes on the handle.

- Install the hex bolts and flange nuts from group 4 of the hardware pack. Using two 1/2" wrenches, tighten securely. See Figure 2.

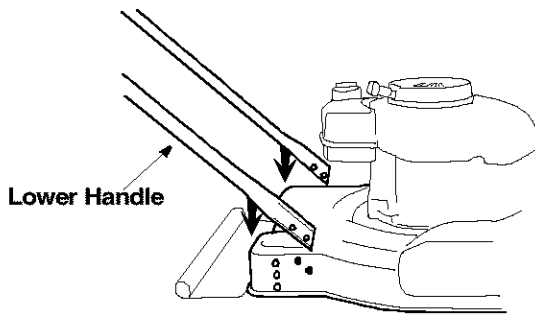

Figure 2

Attaching Upper Handle

- Place the upper handle in position over the lower handle keeping the blade control handle facing up.
- Secure the upper handle to the lower handle using the carriage bolts, lock washers and hex nuts from group 2 of the hardware pack. Make sure that the carriage bolt heads go on the outside of the handle. See Figure 3.

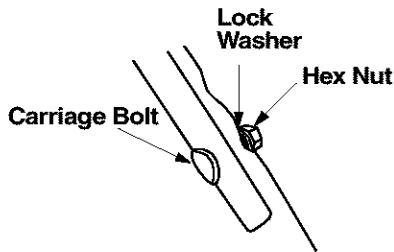

Figure 3

Attaching Brake Cable

NOTE: The brake cable is attached to the engine from the factory. You will have to attach the free end of the cable to the upper handle.

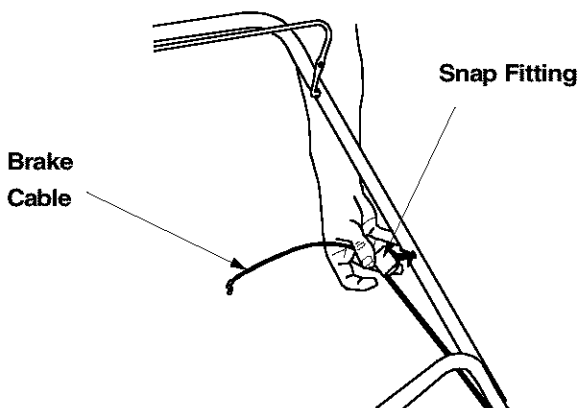

Figure 4

- Route the cable under the lower handle.
- On the opposite end of the cable housing is a snap fitting. The shaft inside the snap fitting fits in the second hole on the upper handle. Press the snap fitting in place as shown in Figure 4. Make sure that the blade control handle is on top of the upper handle.

Attaching Blade Control Handle

NOTE: If the blade control handle got displaced either during shipping and handling or during assembly of other two handles, reassemble it now. If the blade control handle is firmly secured in place, you may proceed to the next assembly.



WARNING: The blade control handle is a safety device. Never attempt to bypass its operations.

- To reattach the blade control handle to the upper handle, first identify the proper holes in the upper handle. This can be done by placing the blade control handle flat against the upper handle. The ends of the blade control handle will approximate the hole positions.
- Insert the curved end of the blade control handle into the right hole. See Figure 5.
- Squeeze the handle in, and insert the straight end of the blade control handle into the left hole of the upper handle.
- Squeeze the blade control handle against the upper handle to check for proper assembly.

NOTE: The hole in the blade control handle must be on the left side and the control handle must touch the upper handle when squeezed.

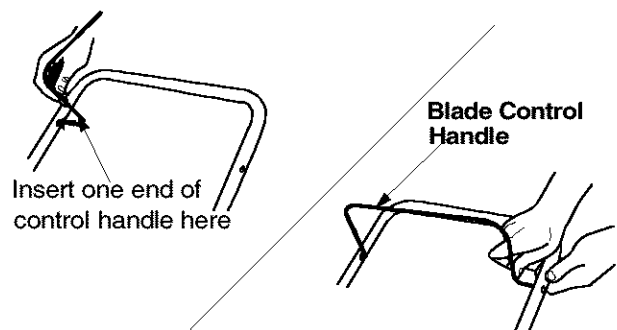

Figure 5

Attaching Z Fitting

- Hold the cable end near the left side of the upper handle and hook the "Z" end of the brake cable into the blade control handle from the inside to the outside. See Figure 6.

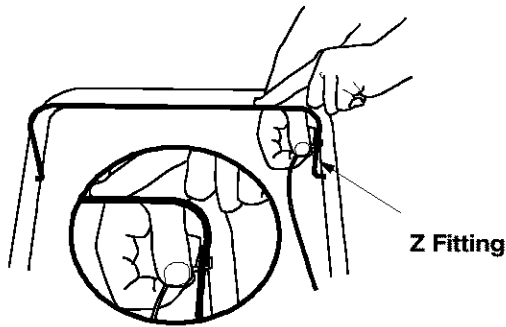

Figure 6

Securing Brake Cable



WARNING: The cable must be routed properly to avoid contact with all sharp edges and hot surfaces. Such contacts damage the cable and render the controls inoperative.

- Secure the cable to the lower left handle near the base of the unit with a cable tie from group 3 of the hardware pack. Trim off extra length of the cable tie. See Figure 7.

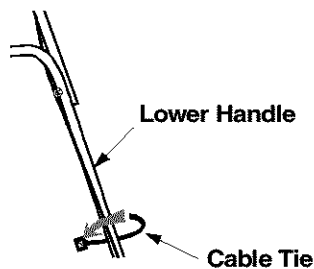

Figure 7

Attaching Wheels

NOTE: The holes provide three cutting heights for your mower. Use the same hole location for all four wheels when assembling. For example, if wheels are to be assembled in the lowest cutting position, use the highest hole on the deck.

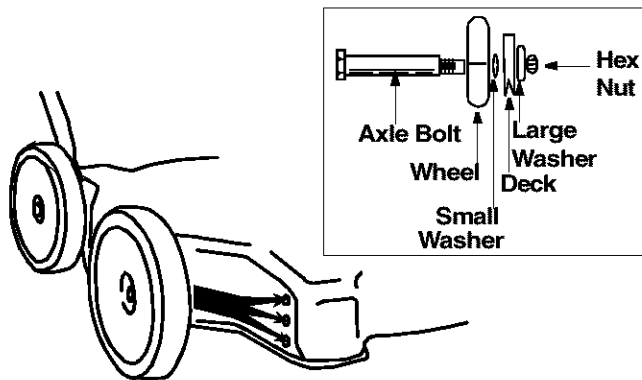

Figure 8

- Block the mower securely.
- Using hardware from group 1 of the hardware pack, place axle bolt through the wheel with the hub side of the wheel facing the deck. See Figure 8.
- Place the small bell washer on the axle bolt with the crown side towards the wheel. See Figure 8.
- Secure the wheel to the deck with the large bell washer and the nut.
- Repeat on other sides.
- Remove blocks and put the mower on ground.

Attaching Chute Deflector

- Align the holes on the chute deflector with the corresponding holes on the deck.
- Using group 5 from hardware pack, place carriage bolts from underside of the deck and up through the chute deflector. See Figure 9.
- Secure each bolt with a washer and lock nut.

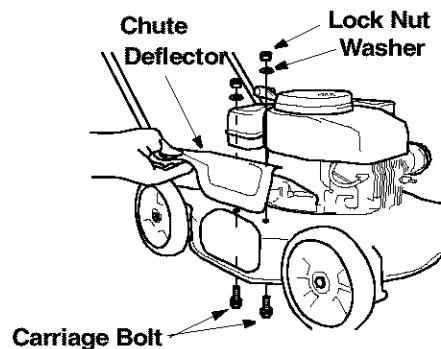

Figure 9

Attaching Starter Rope

- Loosely attach the rope guide (from group 6 of the hardware pack) to the upper handle and thread the lock nut (also in group 6) only a few turns. Do not tighten. Make sure that the rope guide is to the outside of the upper handle. See Figure 10.
- The starter rope is attached to the engine. With the spark plug wire disconnected and grounded, depress the blade control handle and pull the rope out of the engine.
- Slip the starter rope through the gap between the rope guide and the handle. Tighten hex lock nut.

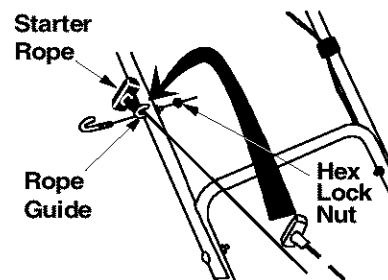

Figure 10

Know Your Lawn Mower

Compare the illustration in with your lawn mower to familiarize yourself with the location of various controls and adjustments.

Throttle Control

The mower engine is equipped with a constant speed throttle, which is set at full throttle for best performance.

Blade Control Handle

The blade control handle is located on the upper handle of the mower. The blade control handle must be depressed in order to operate the unit. Release the blade control handle to stop the engine and the blade.



WARNING: This control mechanism is a safety device. Never attempt to bypass its operations.

Recoil Starter

The recoil starter handle is attached to the handle and is used to start the engine.

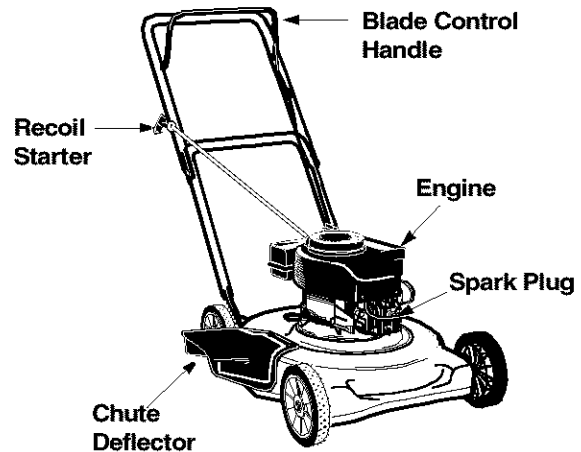

Figure 11

SECTION 5: OPERATING YOUR LAWN MOWER



WARNING: Keep hands and feet away from the chute area on cutting deck. The blade will be rotating whenever the engine is running.

NOTE: For best results, raise the cutting position until you can determine which height is best for your lawn. Refer to instructions for height adjustment on page 11.

Gas and Oil Fill-Up

Service the engine with gasoline and oil as instructed in the separate engine manual packed with your mower. Follow instructions carefully.



WARNING: Never fill fuel tank indoors, with engine running or until the engine has been allowed to cool for at least two minutes after running.

Before Starting

- Attach spark plug wire to spark plug. If unit is equipped with a rubber boot over the spark plug wire, ensure that the metal cap on the end of the spark plug wire (inside the rubber boot) is fastened securely over the metal tip on the spark plug.

To Start Engine and Engage Blade

- If engine is equipped with a primer, prime engine as instructed in the separate engine manual packed with your unit.

- Standing behind the unit, depress the blade control handle and hold it against the upper handle. See Figure 12.

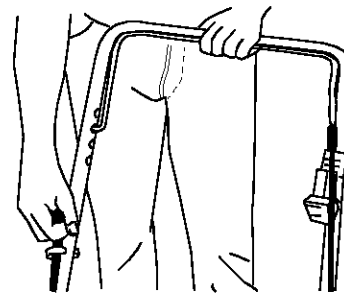

Figure 12

- Grasp starter handle and pull rope out slowly until engine reaches start of compression cycle (rope will pull slightly harder at this point). Let the rope rewind slowly. Pull rope with a rapid, continuous, full arm stroke. Keep a firm grip on starter handle. Return it slowly to the rope guide.

To Stop Engine and Blade

- Release blade control handle to stop engine and blade. Keep away from the moving blade.



WARNING: The blade continues to rotate for a few seconds after engine is shut off.

- Disconnect the spark plug wire and ground it against the engine to prevent accidental starting while equipment is unattended.

Using Your Lawn Mower



WARNING: Never operate your unit without either the rear deflector or entire grass catcher assembly in place.

- Make sure that lawn is clear of stones, sticks, wire, or other objects which could damage lawn mower and/or cause personal injury.
- For best results, do not cut wet grass. New grass or thick grass requires a narrower cut. Blade speed and cutting height should be adjusted to the condition of the lawn.

- For a healthy lawn, never cut more than one-third of the total length of the grass at any one cutting.
- This mower is designed to operate at full throttle.



WARNING: If you strike a foreign object, stop the engine. Remove wire from spark plug, thoroughly inspect the mower for any damage, and repair the damage before restarting and operating the mower. Extensive vibration of the mower during operation is an indication of damage. The unit should be promptly inspected and repaired.

SECTION 6: MAKING ADJUSTMENTS



WARNING: Do not at any time make any adjustment to lawn mower without first stopping engine and disconnecting spark plug wire.

Cutting Height

You can adjust the cutting height of the mower according to your convenience.

- Remove the axle bolts and related hardware from the wheels.
- Reattach the wheels with axle bolts at another hole. Remember to attach all wheels at the same relative position to ensure even cut. Refer to instructions for attaching the wheels in the assembly section of this manual. For higher cutting height, use lower hole on the deck and for lower cutting height, use the upper hole.

Throttle Control

Your lawn mower engine is equipped with a fixed throttle control that does not need adjustment.

Carburetor



WARNING: If any adjustments are made to the engine while the engine is running (e.g. carburetor), keep clear of all moving parts. Be careful of heated surfaces and muffler.

Minor carburetor adjustments may be required to compensate for differences in fuel, temperature, altitude and load. To adjust carburetor, refer to the separate engine manual packed with your mower.

NOTE: A dirty air cleaner will cause an engine to run rough. Be certain air cleaner is clean and attached to the carburetor before adjusting carburetor.

SECTION 7: MAINTAINING YOUR LAWN MOWER

Deck Care

NOTE: We do not recommend the use of pressure washers or garden hose to clean your unit. These may cause damage to electric components spindles, pulleys, bearings or the engine. The use of water will shorten life of the mower and reduce its serviceability.

- The underside of the mower deck should be cleaned after each use to prevent build-up of grass clippings, leaves, dirt or other matter. If this debris is allowed to accumulate, it will invite rust and corrosion, and may cause an uneven discharge of grass clippings at the next cutting.

- The deck may be cleaned by tilting the mower and scraping clean with a suitable tool (make certain the spark plug wire is disconnected).

Lubrication

(Refer to Lubrication Chart in Figure 13.)



Always stop engine and disconnect spark plug wire before cleaning, lubricating or doing any kind of work on lawn mower.

Blade Control

- Lubricate the pivot points on the blade control handle and the brake cable at least once a season with light oil. The blade control must operate freely in both directions.

Wheels

- The wheels require no lubrication. However, if the wheels are removed for any reason, lubricate the surface of the axle bolt and the inner surface of the wheel with light oil. Engine oil may also be used.

When tipping the unit, empty the fuel tank and keep engine spark plug side up.

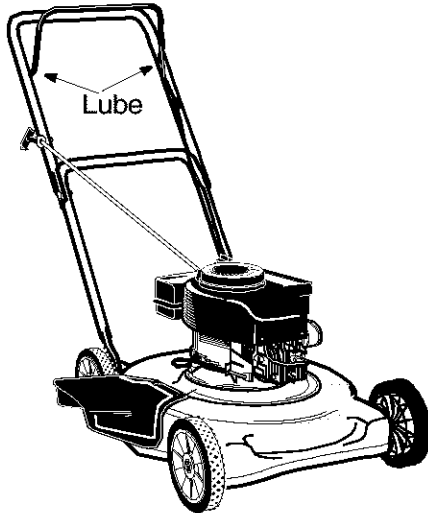

Figure 13 : Lubrication Chart

Blade Care

- Periodically inspect the blade adapter for cracks, especially if you strike a foreign object. Replace when necessary.



WARNING: When removing the cutting blade for sharpening or replacement, protect hands by using heavy gloves or a rag to grasp the cutting blade.

To remove blade

- Remove the bolt and blade support or bell washer which hold the blade and adapter to the engine crankshaft. See Figure 14. Remove the blade and adapter from the crankshaft.

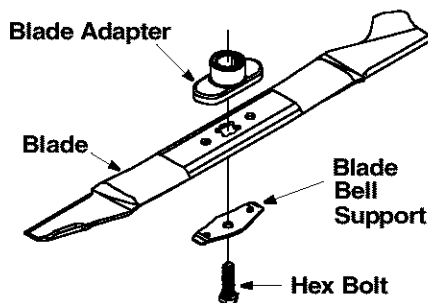

Figure 14

To balance blade

- When sharpening the blade, follow original angle of grind as a guide. It is extremely important to grind off all edges equally to keep the blade balanced.

NOTE: An unbalanced blade will cause excessive vibration when rotating at high speeds and may cause damage to the mower and/or personal injury.

- Test the blade by balancing it on a round shaft screwdriver. See Figure 15.
- Remove metal from the heavy side until it balances evenly. Always remove blade from the adapter for the best test of balance.

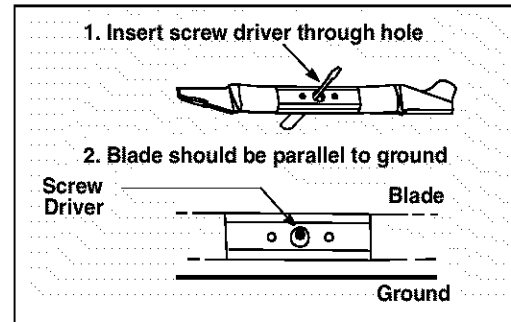

Figure 15

To reassemble blade

- Lubricate the engine crankshaft and the inner surface of the blade adapter with light oil (or engine oil). Also lubricate the bolt holes, bolts and inner surface of the nuts.
- Install the blade adapter on the crankshaft with the "star" away from the engine. Refer to Figure 14.
- Place the blade with the side marked bottom (or with part number) facing away from the adapter.
- Align the blade bell support over the blade with the tabs in the holes of the blade and insert the hex bolt. Tighten the hex bolt to the torque listed in the "Blade Mounting Torque" section below.

Blade Mounting Torque

Center Bolt: 450 in. lbs. min., 600 in. lbs. max.

IMPORTANT: To ensure safe operation, all nuts and bolts must be checked periodically for correct tightness.

Replacing Rear Flap

- To remove rear flap, compress the hinge clips and remove from the slots in rear of deck.
- Attach new rear flap by placing new spring clips in the slots on the flap. Then compress the spring clips and reinsert in slots in rear of deck.

Engine

- Follow engine manual for instruction and schedule of maintenance and lubrication.

SECTION 8: OFF-SEASON STORAGE

The following steps should be taken to prepare lawn mower for storage.

- Clean and lubricate mower thoroughly as described in the lubrication instructions.
- Refer to engine manual for correct engine storage instructions.
- Coat mower's cutting blade with chassis grease to prevent rusting.

- Store mower in a dry, clean area. Do not store next to corrosive materials, such as fertilizer.

NOTE: *When storing any type of power equipment in an unventilated or metal storage shed, care should be taken to rust-proof the equipment. Using a light oil or silicone, coat the equipment, especially cables and all moving parts.*

SECTION 9: TROUBLE SHOOTING GUIDE

Trouble	Possible Cause(s)	Corrective Actions
Engine fails to start	<ol style="list-style-type: none"> 1. Blade control handle disengaged. 2. Spark plug wire disconnected. 3. Dirty aircleaner. 4. Primer button not depressed. 5. Fuel tank empty or stale fuel. 6. Blocked fuel line. 7. Faulty spark plug. 8. Engine flooded. 	<ol style="list-style-type: none"> 1. Engage blade control handle. 2. Connect wire to spark plug. 3. Refer to the engine manual packed with your unit. 4. Refer to the engine manual packed with your unit. 5. Clean fuel line. 6. Clean, adjust gap or replace. 7. Refer to the engine manual. 8. Wait for a while and crank the engine.
Engine runs erratic	<ol style="list-style-type: none"> 1. Blocked fuel line or stale fuel. 2. Carburetor out of adjustment. 	<ol style="list-style-type: none"> 1. Clean fuel line; fill tank with clean, fresh gasoline. 2. Refer to the engine manual packed with your unit.
Engine overheats	<ol style="list-style-type: none"> 1. Engine oil level low. 2. Dirty air cleaner. 3. Air flow restricted. 4. Carburetor not adjusted properly. 	<ol style="list-style-type: none"> 1. Fill crankcase with proper oil. 2. Refer to the engine manual packed with your unit. 3. Stop engine and disconnect spark plug wire. Remove blower housing and clean. 4. Refer to the engine manual.
Occasional skip (hesitates) at high speed	<ol style="list-style-type: none"> 1. Spark plug gap too close. 2. Carburetor idle mixture adjustment improperly set. 	<ol style="list-style-type: none"> 1. Adjust gap to .030". 2. Refer to the engine manual packed with your unit.
Idles poorly	<ol style="list-style-type: none"> 1. Spark plug fouled, faulty or gap too wide. 2. Carburetor not adjusted. 	<ol style="list-style-type: none"> 1. Reset gap to .030" or replace spark plug. 2. Refer to the engine manual.
Excessive vibration	<ol style="list-style-type: none"> 1. Cutting blade loose or unbalanced. 2. Bent cutting blade. 	<ol style="list-style-type: none"> 1. Tighten blade and adapter. Balance blade. 2. See an authorized service dealer.
Mower will not mulch grass	<ol style="list-style-type: none"> 1. Wet grass. 2. Excessively high grass. 	<ol style="list-style-type: none"> 1. Wait until later to cut. 2. Mow once at a high cutting height, then mow again at desired height.
Uneven cut	<ol style="list-style-type: none"> 1. Wheels positioned incorrectly. 2. Dull blade. 	<ol style="list-style-type: none"> 1. Place all four wheels in same height position. 2. Sharpen or replace blade.



NOTE: *For repairs beyond those listed above, contact your local authorized service representative.*

SECTION 10: PARTS LIST FOR MODEL SERIES 020

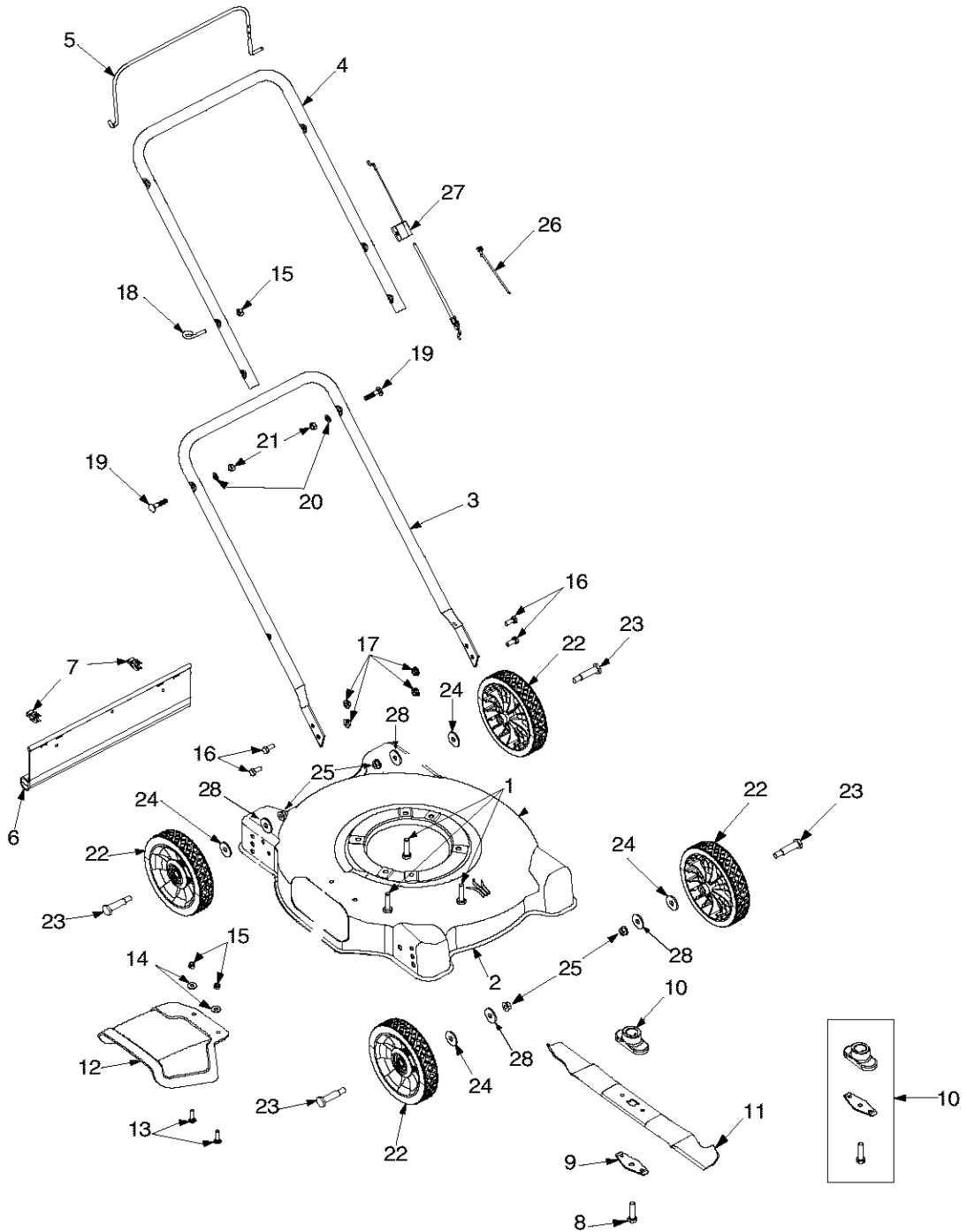

Model Series 020

Ref. No.	Part No.	Description
1.	710-0654A	Hex Ind. Washer Screw 3/8-16 x 1.0
2.	782-0048	Cutting Deck: 20"
3.	749-1077	Lower Handle
4.	749-1076	Upper Handle
5.	747-0976A	Control Handle (Bail)
6.	731-0872A	Rear Flap
7.	17098	Hinge Clip
8.	710-1044	Screw 3/8-24 x 1.5" Group 8
9.	936-0524A	Blade Bell Support
10.	753-0588	Blade Adapter Kit
11.	742-0640	Cutting Blade
12.	731-0064	Discharge Chute
13.	710-0932	Carriage Screw 1/4-20 x 1.0"
14.	736-0173	Flat Washer
15.	712-0324	Lock Nut 1/4-20
16.	710-3008	Hex Bolt 5/16-18
17.	712-3004A	Lock Nut 5/16-18
18.	710-1205	Eye Bolt
19.	710-0262	Carriage Bolt 5/16-18 x 1.5"
20.	736-0119	Lock Washer
21.	712-0267	Nut 5/16-18
22.	734-1779	Wheel
23.	738-0533	Shoulder Screw .498 x 1.635
24.	736-0105	Bell Washer
25.	712-0798	Flange Lock Nut
26.	726-0240	Cable Tie
27.	746-0946	Control Cable (48.25" lg.)
	746-0957	Control Cable (37.25" lg.)
28.	736-0331	Bell Washer

MANUFACTURER'S LIMITED WARRANTY

The limited warranty set forth below is given by MTD PRODUCTS INC ("MTD") with respect to new merchandise purchased and used in the United States, its possessions and territories.

MTD warrants this product against defects in material and workmanship for a period of one (1) year commencing on the date of original purchase and will, at its option, repair or replace, free of charge, any part found to be defective in material or workmanship. This limited warranty shall only apply if this product has been operated and maintained in accordance with the Operator's Manual furnished with the product, and has not been subject to misuse, abuse, commercial use, neglect, accident, improper maintenance, alteration, vandalism, theft, fire, water or damage because of other peril or natural disaster. Damage resulting from the installation or use of any accessory or attachment not approved by MTD Products Inc. for use with the product(s) covered by this manual will void your warranty as to any resulting damages.

Normal wear parts or components thereof are subject to separate terms as follows: All normal wear part or component failures will be covered on the product for a period of 90 days regardless of cause. After 90 days, but within the one-year period, normal wear part failures will be covered ONLY IF caused by defects in material or workmanship of OTHER component parts. Normal wear parts and components include, but are not limited to, belts, blades, blade adapters, grass bags, rider deck wheels, seats, snow thrower skid shoes, shave plates and tires. Batteries are covered by a 90-day limited replacement warranty.

HOW TO OBTAIN SERVICE: Warranty service is available, WITH PROOF OF PURCHASE THROUGH YOUR LOCAL AUTHORIZED SERVICE DEALER. To locate the dealer in your area, please check for a listing in the Yellow Pages or contact the Customer Service Department of MTD PRODUCTS INC by calling 1-800-800-7310 or writing to P.O. Box 368022, Cleveland, Ohio 44136-9722.

This limited warranty does not provide coverage in the following cases:

- a. The engine or component parts thereof. These items carry a separate manufacturer's warranty. Please refer to the applicable manufacturer's warranty on these items.
- b. Log splitter pumps, valves and cylinders have a separate one year warranty.

- c. Routine maintenance items such as lubricants, filters, blade sharpening and tune-ups, or adjustments such as brake adjustments, clutch adjustments or deck adjustments; and normal deterioration of the exterior finish due to use or exposure.
- d. MTD does not extend any warranty for products sold or exported outside of the United States of America, its possessions and territories, except those sold through MTD's authorized channels of export distribution.

No implied warranty, including any implied warranty of merchantability or fitness for a particular purpose, applies after the applicable period of express written warranty above as to the parts as identified. No other express warranty or guaranty, whether written or oral, except as mentioned above, given by any person or entity, including a dealer or retailer, with respect to any product shall bind MTD. During the period of the Warranty, the exclusive remedy is repair or replacement of the product as set forth above. (Some states do not allow limitations on how long an implied warranty lasts, so the above limitation may not apply to you.)

The provisions as set forth in this Warranty provide the sole and exclusive remedy arising from the sales. MTD shall not be liable for incidental or consequential loss or damages including, without limitation, expenses incurred for substitute or replacement lawn care services, for transportation or for related expenses, or for rental expenses to temporarily replace a warranted product. (Some states do not allow the exclusion or limitation of incidental or consequential damages, so the above exclusion or limitation may not apply to you.)

In no event shall recovery of any kind be greater than the amount of the purchase price of the product sold. Alteration of the safety features of the product shall void this Warranty. You assume the risk and liability for loss, damage, or injury to you and your property and/or to others and their property arising out of the use or misuse or inability to use the product.

This limited warranty shall not extend to anyone other than the original purchaser, original lessee or the person for whom it was purchased as a gift.

How State Law Relates to this Warranty: This limited warranty gives you specific legal rights, and you may also have other rights which vary from state to state.