

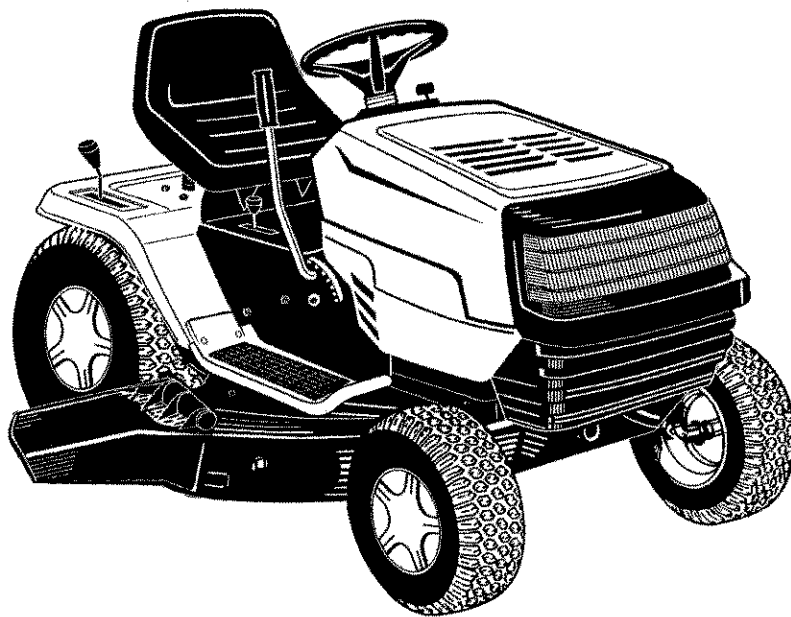

# OPERATOR'S MANUAL



**Hydrostatic Lawn  
Tractor  
Model Series  
690 - 699**

## **IMPORTANT: READ SAFETY RULES AND INSTRUCTIONS CAREFULLY**

**Warning:** This unit is equipped with an internal combustion engine and should not be used on or near any unimproved forest-covered, brush-covered or grass-covered land unless the engine's exhaust system is equipped with a spark arrester meeting applicable local or state laws (if any). If a spark arrester is used, it should be maintained in effective working order by the operator. In the State of California the above is required by law (Section 4442 of the California Public Resources Code). Other states may have similar laws. Federal laws apply on federal lands. A spark arrester for the muffler is available through your nearest engine authorized service dealer or contact the service department, P.O. Box 368022 Cleveland, Ohio 44136-9722.

**MTD PRODUCTS INC. P.O. BOX 368022 CLEVELAND, OHIO 44136-9722**

## TABLE OF CONTENTS

Content	Page
Important Safe Operation Practices.....	3
Slope Gauge.....	7
Assembling Your Lawn Tractor.....	8
Know Your Lawn Tractor.....	12
Operating Your Lawn Tractor.....	14
Making Adjustments.....	15
Maintaining Your Lawn Tractor.....	17
Optional Equipment.....	22
Troubleshooting.....	23

## FINDING MODEL NUMBER

This Operator's Manual is an important part of your new lawn tractor. It will help you assemble, prepare and maintain the unit for best performance. Please read and understand what it says.



**Before you start assembling your new equipment**, please locate the model plate on the equipment and copy the information from it in the space provided below. The information on the model plate is very important if you need help from our Customer Support Department or an authorized dealer.

- You can locate the model number by pivoting the seat forward and looking under it at the seat pivot bracket. A sample model plate is explained below. For future reference, please copy the model number and the serial number of the equipment in the space below.

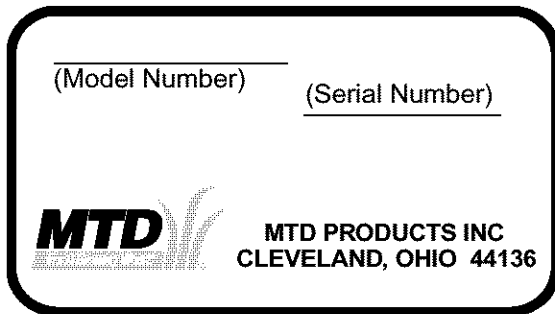

Copy the model number here: \_\_\_\_\_

Copy the serial number here: \_\_\_\_\_

## CALLING CUSTOMER SUPPORT

If you have difficulty assembling this product or have any questions regarding the controls, operation or maintenance of this unit, please call the Customer Support Department.



Call **1- (330) 220-4MTD (4683)** or **1- (800)-800-7310** to reach a Customer Support representative. Please have your unit's model number and serial number ready when you call. See previous section to locate this information. You will be asked to enter the serial number in order to process your call.

For more details about your unit, visit our website at [www.mtdproducts.com](http://www.mtdproducts.com)

---

## SECTION 1: IMPORTANT SAFE OPERATION PRACTICES



**WARNING:** This symbol points out important safety instructions which, if not followed, could endanger the personal safety and/or property of yourself and others. Read and follow all instructions in this manual before attempting to operate this machine. Failure to comply with these instructions may result in personal injury. When you see this symbol—heed its warning.



**DANGER:** This machine was built to be operated according to the rules for safe operation in this manual. As with any type of power equipment, carelessness or error on the part of the operator can result in serious injury. This machine is capable of amputating hands and feet and throwing objects. Failure to observe the following safety instructions could result in serious injury or death.



**WARNING:** Engine exhaust, some of its constituents, and certain vehicle components contain or emit chemicals known to the State of California to cause cancer and birth defects or other reproductive harm.

### GENERAL OPERATION

1. Read, understand, and follow all instructions on the machine and in the manual(s) before attempting to assemble and operate. Keep this manual in a safe place for future and regular reference and for ordering replacement parts.
2. Be familiar with all controls and their proper operation. Know how to stop the machine and disengage them quickly.
3. Never allow children under 14 years old to operate this machine. Children 14 years old and over should read and understand the operation instructions and safety rules in this manual and should be trained and supervised by a parent.
4. Never allow adults to operate this machine without proper instruction.
5. To help avoid blade contact or a thrown object injury, keep bystanders, helpers, children and pets at least 75 feet from the machine while it is in operation. Stop machine if anyone enters the area.
6. Thoroughly inspect the area where the equipment is to be used. Remove all stones, sticks, wire, bones, toys, and other foreign objects which could be picked up and thrown by the blade(s). Thrown objects can cause serious personal injury.
7. Plan your mowing pattern to avoid discharge of material toward roads, sidewalks, bystanders and the like. Also, avoid discharging material against a wall or obstruction which may cause discharged material to ricochet back toward the operator.
8. Always wear safety glasses or safety goggles during operation and while performing an adjustment or repair to protect your eyes. Thrown objects which ricochet can cause serious injury to the eyes.
9. Wear sturdy, rough-soled work shoes and close-fitting slacks and shirts. Loose fitting clothes and jewelry can be caught in movable parts. Never operate this machine in bare feet or sandals.
10. Be aware of the mower and attachment discharge direction and do not point it at anyone. Do not operate the mower without the discharge cover or entire grass catcher in its proper place.
11. Do not put hands or feet near rotating parts or under the cutting deck. Contact with the blade(s) can amputate hands and feet.
12. A missing or damaged discharge cover can cause blade contact or thrown object injuries.
13. Stop the blade(s) when crossing gravel drives, walks, or roads and while not cutting grass.
14. Watch for traffic when operating near or crossing roadways. This machine is not intended for use on any public roadway.
15. Do not operate the machine while under the influence of alcohol or drugs.
16. Mow only in daylight or good artificial light.
17. Never carry passengers.
18. Disengage blade(s) before shifting into reverse. Back up slowly. Always look down and behind before and while backing to avoid a back-over accident.
19. Slow down before turning. Operate the machine smoothly. Avoid erratic operation and excessive speed.
20. Disengage blade(s), place control lever in neutral, set parking brake, stop engine and wait until the blade(s) come to a complete stop before removing grass catcher, emptying grass, unclogging chute, removing any grass or debris, or making any adjustments.
21. Never leave a running machine unattended. Always turn off blade(s), set parking brake, stop engine and remove key before dismounting.
22. Use extra care when loading or unloading the machine into a trailer or truck. This unit should not be driven up or down ramp(s), because the unit could tip over, causing serious personal injury. The unit must be pushed manually on ramp(s) to load or unload properly.
23. Muffler and engine become hot and can cause a burn. Do not touch.
24. Check overhead clearances carefully before driving under low hanging tree branches, wires, door

openings etc., where the operator may be struck or pulled from the unit, which could result in serious injury.

25. Depress the brake pedal completely and place the control lever in neutral before attempting to start engine.
26. Your machine is designed to cut normal residential grass of a height no more than 10". Do not attempt to mow through unusually tall, dry grass (e.g., pasture) or piles of dry leaves. Dry grass or leaves may contact the engine exhaust and/or build up on the mower deck presenting a potential fire hazard.
27. Use only accessories and attachments approved for this machine by the machine manufacturer. Read, understand and follow all instructions provided with the approved accessory or attachment.
28. Data indicates that operators, age 60 years and above, are involved in a large percentage of riding mower-related injuries. These operators should evaluate their ability to operate the riding mower safely enough to protect themselves and others from serious injury.
29. If situations occur which are not covered in this manual, use care and good judgment. Contact an authorized service dealer for assistance.

## **SLOPE OPERATION**

Slopes are a major factor related to loss of control and tip-over accidents which can result in severe injury or death. All slopes require extra caution. If you cannot back up the slope or if you feel uneasy on it, do not mow it.

For your safety, use the slope gauge included as part of this manual to measure slopes before operating this unit on a sloped or hilly area. If the slope is greater than 15 degrees as shown on the slope gauge, do not operate this unit on that area or serious injury could result.

### **DO:**

1. Mow up and down slopes, not across. Exercise extreme caution when changing direction on slopes.
2. Watch for holes, ruts, bumps, rocks, or other hidden objects. Uneven terrain could overturn the machine. Tall grass can hide obstacles.
3. Use slow speed. Choose a low enough speed setting so that you will not have to stop or shift while on the slope. Tires may lose traction on slopes even though the brakes are functioning properly. Always keep machine in gear when going down slopes to take advantage of engine braking action.
4. Follow the manufacturer's recommendations for wheel weights or counterweights to improve stability.
5. Use extra care with grass catchers or other

attachments. These can change the stability of the machine.

6. Keep all movement on the slopes slow and gradual. Do not make sudden changes in speed or direction. Rapid engagement or braking could cause the front of the machine to lift and rapidly flip over backwards which could cause serious injury.
7. Avoid starting or stopping on a slope. If tires lose traction, disengage the blade(s) and proceed slowly straight down the slope.

### **DO NOT:**

1. Do not turn on slopes unless necessary; then, turn slowly and gradually downhill, if possible.
2. Do not mow near drop-offs, ditches or embankments. The mower could suddenly turn over if a wheel is over the edge of a cliff, ditch, or if an edge caves in.
3. Do not try to stabilize the machine by putting your foot on the ground.
4. Do not use a grass catcher on steep slopes.
5. Do not mow on wet grass. Reduced traction could cause sliding.
6. Do not shift to neutral and coast downhill. Over-speeding may cause the operator to lose control of the machine resulting in serious injury or death.
7. Do not tow heavy pull behind attachments (e.g. loaded dump cart, lawn roller, etc.) on slopes greater than 5 degrees. When going down hill, the extra weight tends to push the tractor and may cause you to lose control. (e.g. tractor may speed up, braking and steering ability are reduced, attachment may jack-knife and cause tractor to overturn).

### **CHILDREN**

1. Tragic accidents can occur if the operator is not alert to the presence of children. Children are often attracted to the machine and the mowing activity. They do not understand the dangers. Never assume that children will remain where you last saw them.
  - a. Keep children out of the mowing area and in watchful care of a responsible adult other than the operator.
  - b. Be alert and turn machine off if a child enters the area.
  - c. Before and while backing, look behind and down for small children.
  - d. Never carry children, even with the blade(s) shut off. They may fall off and be seriously injured or interfere with safe machine operation.
  - e. Use extreme care when approaching blind corners, doorways, shrubs, trees or other objects that may block your vision of a child who may run into the machine.

- f. Disengage the cutting blade(s) before shifting in reverse. The “No-Cut-In Reverse” feature is a reminder not to cut in reverse and to help avoid back over accidents. Do not defeat it.
  - g. Keep children away from hot or running engines. They can suffer burns from a hot muffler.
  - h. Remove key when machine is unattended to prevent unauthorized operation.
9. Never allow children under 14 years old to operate the machine. Children 14 years old and over should read and understand the operation instructions and safety rules in this manual and should be trained and supervised by a parent.

## TOWING

1. Tow only with a machine that has a hitch designed for towing. Do not attach towed equipment except at the hitch point.
2. Follow the manufacturers recommendation for weight limits for towed equipment and towing on slopes.
3. Never allow children or others in or on towed equipment.
4. On slopes, the weight of the towed equipment may cause loss of traction and loss of control.
5. Travel slowly and allow extra distance to stop.
6. Do not shift to neutral and coast downhill.

## SERVICE

### SAFE HANDLING OF GASOLINE:

1. **To avoid personal injury or property damage** use extreme care in handling gasoline. Gasoline is extremely flammable and the vapors are explosive. Serious personal injury can occur when gasoline is spilled on yourself or your clothes which can ignite. Wash your skin and change clothes immediately.
  - a. Use only an approved gasoline container.
  - b. Never fill containers inside a vehicle or on a truck or trailer bed with a plastic liner. Always place containers on the ground away from your vehicle before filling.
  - c. When practical, remove gas-powered equipment from the truck or trailer and refuel it on the ground. If this is not possible, then refuel such equipment on a trailer with a portable container, rather than from a gasoline dispenser nozzle.
  - d. Keep the nozzle in contact with the rim of the fuel tank or container opening at all times until fueling is complete. Do not use a nozzle lock-open device.
  - e. Extinguish all cigarettes, cigars, pipes and other sources of ignition.
  - f. Never fuel machine indoors.
  - g. Never remove gas cap or add fuel while the

- engine is hot or running. Allow engine to cool at least two minutes before refueling.
- h. Never over fill fuel tank. Fill tank to no more than ½ inch below bottom of filler neck to allow space for fuel expansion.
- i. Replace gasoline cap and tighten securely.
- j. If gasoline is spilled, wipe it off the engine and equipment. Move unit to another area. Wait 5 minutes before starting the engine.
- k. To reduce fire hazards, keep machine free of grass, leaves, or other debris build-up. Clean up oil or fuel spillage and remove any fuel soaked debris.
- l. Never store the machine or fuel container inside where there is an open flame, spark or pilot light as on a water heater, space heater, furnace, clothes dryer or other gas appliances.
- m. Allow a machine to cool at least 5 minutes before storing.

### GENERAL SERVICE:

1. Never run an engine indoors or in a poorly ventilated area. Engine exhaust contains carbon monoxide, an odorless, and deadly gas.
2. Before cleaning, repairing, or inspecting, make certain the blade(s) and all moving parts have stopped. Disconnect the spark plug wire and ground against the engine to prevent unintended starting.
3. Periodically check to make sure the blades come to complete stop within approximately (5) five seconds after operating the blade disengagement control. If the blades do not stop within the this time frame, your unit should be serviced professionally by an authorized service dealer.
4. Check brake operation frequently as it is subjected to wear during normal operation. Adjust and service as required.
5. Check the blade(s) and engine mounting bolts at frequent intervals for proper tightness. Also, visually inspect blade(s) for damage (e.g., excessive wear, bent, cracked). Replace the blade(s) with the original equipment manufacturer’s (O.E.M.) blade(s) only, listed in this manual. “Use of parts which do not meet the original equipment specifications may lead to improper performance and compromise safety!”
6. Mower blades are sharp. Wrap the blade or wear gloves, and use extra caution when servicing them.
7. Keep all nuts, bolts, and screws tight to be sure the equipment is in safe working condition.
8. Never tamper with the safety interlock system or other safety devices. Check their proper operation regularly.
9. After striking a foreign object, stop the engine, disconnect the spark plug wire(s) and ground against the engine. Thoroughly inspect the

machine for any damage. Repair the damage before starting and operating.

10. Never attempt to make adjustments or repairs to the machine while the engine is running.
11. Grass catcher components and the discharge cover are subject to wear and damage which could expose moving parts or allow objects to be thrown. For safety protection, frequently check components and replace immediately with original equipment manufacturer's (O.E.M.) parts only, listed in this

manual. "Use of parts which do not meet the original equipment specifications may lead to improper performance and compromise safety!"

12. Do not change the engine governor settings or over-speed the engine. The governor controls the maximum safe operating speed of the engine.
13. Maintain or replace safety and instruction labels, as necessary.
14. Observe proper disposal laws and regulations for gas, oil, etc. to protect the environment.



**WARNING: YOUR RESPONSIBILITY** Restrict the use of this power machine to persons who read, understand and follow the warnings and instructions in this manual and on the machine.

**NOTE:** Not all safety labels shown may apply to your lawn tractor.

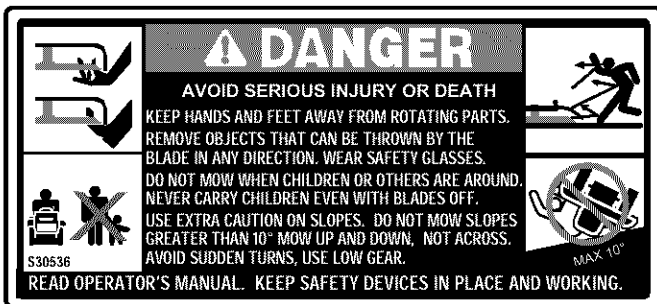

Label shape may vary by tractor model. Label contents do not vary.

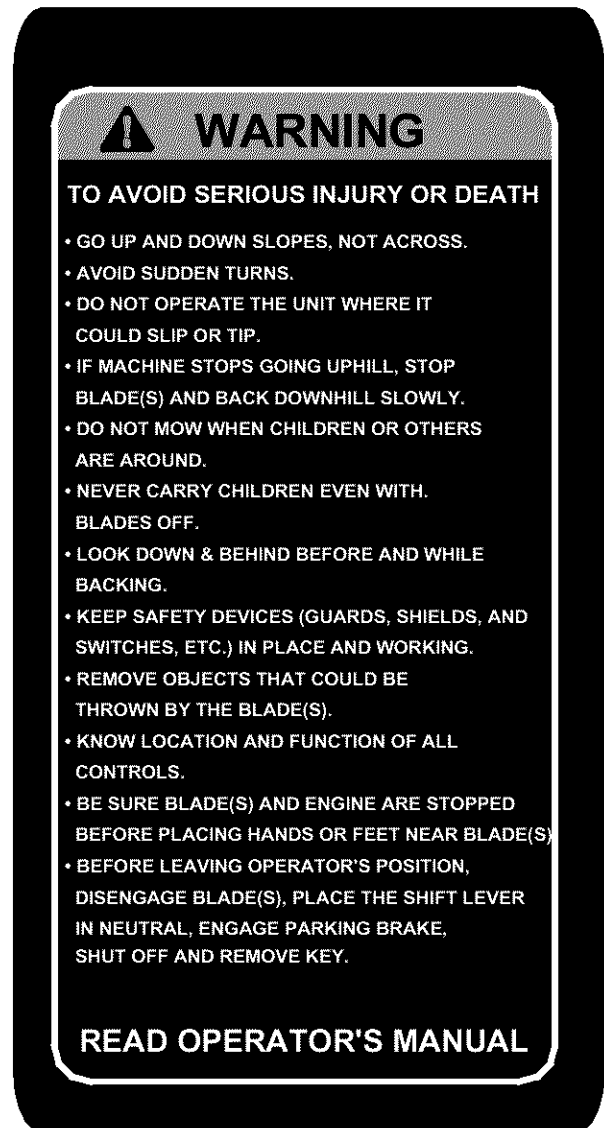

SECTION 2: SLOPE GAUGE

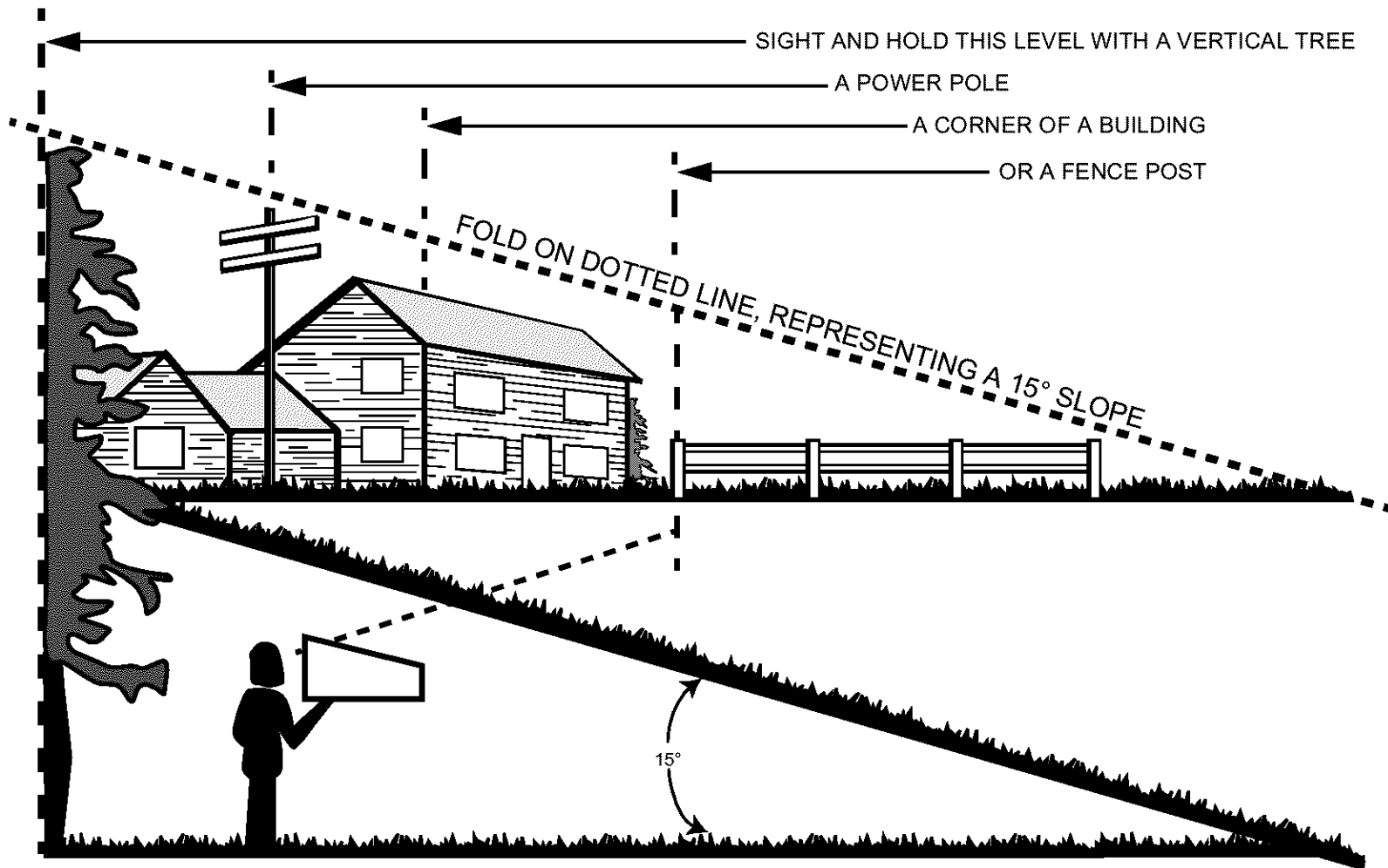

WARNING

Do not mow on inclines with a slope in excess of 15 degrees (a rise of approximately 2-1/2 feet every 10 feet). A riding mower could overturn and cause serious injury. If operating a walk-behind mower on such a slope, it is extremely difficult to maintain your footing and you could slip, resulting in serious injury. Operate RIDING mowers up and down slopes, never across the face of slopes.

## SECTION 3: ASSEMBLING YOUR LAWN TRACTOR

**NOTE:** This manual covers various models of hydrostatic tractors within the 690 series. Please use instructions pertaining only to your tractor.

### Unpacking

- Remove all screws from top of the crate using 1/4" hex head socket or a flat blade screwdriver.
- To remove ends, grasp top board on the end, and pull towards you in downward motion. (A hammer may be helpful). Set panel aside to avoid tire damage. Repeat procedure on other sides.
- Remove and discard plastic bag which covers unit.
- Loose parts (may include the owner's guide, steering wheel, optional oil drain sleeve or hose, battery fluid, chute deflector, optional mulching plug, etc.) are on the seat or in a box wrapped in plastic. Carefully cut and remove the plastic wrap. Remove the loose parts.
- Make sure that parking brake and hydrostatic transmission relief valve are released and unit is in neutral. See page 12-12 for the location of the parking brake release and the hydrostatic relief valve.
- Raise the deck and push the unit off the skid.

**NOTE:** Reference to right or left side of the unit is observed from the operating position on the driver's seat, facing forward.

### Tools Required

1. Socket wrench 1/4" or flat blade screwdriver
  2. Adjustable or socket wrench 1/2" \*
  3. Adjustable or socket wrench 9/16"
  4. Pair of adjustable or socket wrenches 7/16"
- If your tractor steering wheel cap is square, you must use a socket wrench to install the steering wheel.

### Handling Battery



**WARNING:** The battery contains sulfuric acid. This battery acid must be handled with great care as contact with it can burn and blister skin. Wear protective clothing (goggles, rubber gloves and apron) when working with it. Keep batteries out of the reach of children.

**IMPORTANT:** Should battery acid accidentally splatter into the eyes or onto the face, rinse the affected area immediately with clean, cold water. Refer to the antidotes mentioned below. If there is any further discomfort, seek prompt medical attention.

### Antidote

Use the following antidotes if you come in contact with the battery acid.

External - Flush with water.

Internal - Drink large quantities of water or milk. Follow with milk of magnesia, beaten eggs or vegetable oil. Call physician immediately.

Eyes - Flush with cool water for at least 15 minutes, then get prompt medical attention.

If **acid spills on clothing**, first dilute it with clean water, then neutralize with a solution of ammonia/ water or baking soda/water.

**IMPORTANT:** Since battery acid is corrosive, do not pour it into any sink or drain. Before discarding empty electrolyte containers, rinse with a neutralizing solution.



**WARNING:** To avoid sparks, **NEVER** connect or disconnect charger clips to battery while charger is turned on.

Keep all lighted materials (cigarettes, matches, lighters) away from the battery as the hydrogen gas generated during charging can be combustible.

As a further precaution, only charge the battery in a well-ventilated area. Make certain venting path of battery drain tube (if equipped) is always open.

### Identifying Battery Type

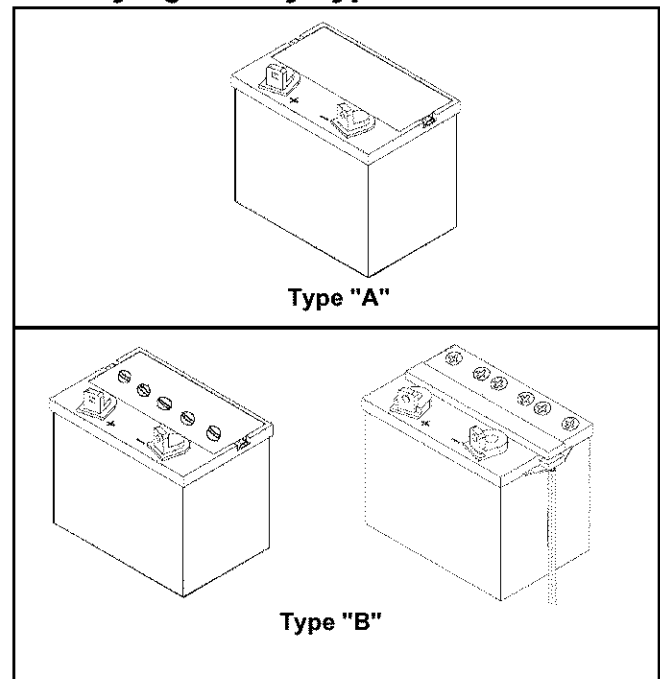

Figure 1



- Compare the battery in your lawn tractor (located under the seat) with the illustration above. Type “A” batteries are activated and are ready to use. Type “B” batteries must be filled with battery fluid (acid) and charged before they are put into service. Follow instructions which apply to the battery in your lawn tractor only.

## Activating & Charging Battery

(Type “B” Battery Only)



**WARNING:** Do not activate battery (i.e. fill with battery acid) until battery is actually placed in service. Read warnings about battery usage in the previous page before activating the battery.

- Pivot the seat pivot bracket forward. Unhook the strap which secures the battery (hook is on rear frame, under the fender). Disconnect the positive cable from the positive terminal. Save the hardware for reassembly.
- Remove the battery from the lawn tractor, paying attention to how the battery is placed in the unit, and how the drain tube (attached to the battery) is routed.
- Activate the battery as instructed in the “Quick Start” brochure included with the battery fluid. Read instructions carefully.

**NOTE:** You can continue to assemble the lawn tractor while the battery is standing for 30 minutes after acid fill-up, and later while you are charging the battery.

**IMPORTANT:** To obtain maximum life from the battery, charge it prior to initial use.

- Battery P/N 725-1705D: Charge at 2-3 amps for one hour.
- Battery P/N 725-1707D, 725-0453G, and 725-1750: Charge at 6 amps for one hour.
- Charge battery after the 30-minute standing period.

**NOTE:** If you charge the battery at a lower AMP rate, use a hydrometer to make sure the battery is completely charged. The hydrometer should read 1.260 minimum at an electrolyte temperature of 60-110°F.



**WARNING:** Do not charge the tractor battery at more than 6 amps.

## Attaching Steering Wheel

- The hardware for attaching the steering wheel has been packed inside the steering wheel. Carefully pry off the steering wheel cap and remove the hardware.
- Remove the steering bellow from the lift lever on the right side of the tractor.

- Place the steering bellow over the steering shaft extending through the dash. See Figure 2.

**NOTE:** If the openings on each end of the steering bellow are of two sizes, the smaller end goes down against the dash of the lawn tractor.

- With the wheels pointing straight, place the steering wheel over the steering shaft, positioning the steering wheel as desired.
- Place the washer with the cupped side down over the steering shaft. Secure with hex lock bolt. See Figure 2.

**NOTE:** If your tractor steering wheel cap is square, you *must* use a socket wrench.

- Place the steering wheel cap over the center of the steering wheel and press it with your hand.

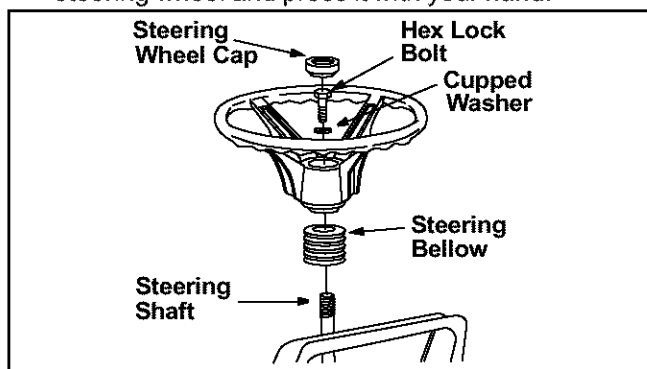

Figure 2

## Attaching Seat

**NOTE:** Your tractor is equipped with one of the following types of seats. Identify the seat type from the illustrations below, and follow instructions pertaining to your tractor.

### Manual Adjustment Seat

- Remove the four screws from the seat and remove the packing straps from two of the bolts. Turn the seat around and place it in position against the seat pivot bracket, lining up the slotted holes in the pivot bracket with the holes in the seat. Select desired position for the seat, and secure with the four screws removed earlier. See Figure 3.

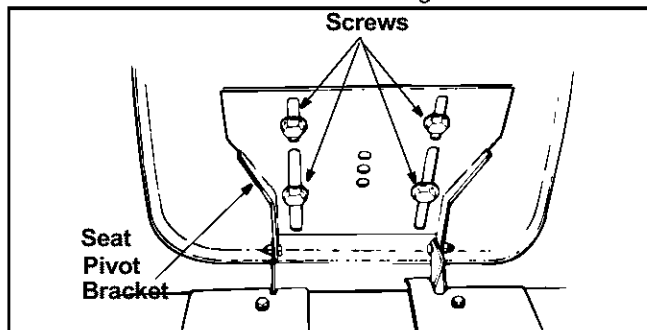

Figure 3

**NOTE:** The seat may have been shipped in a box. Remove the four screws from the bottom of seat and place seat in position against the seat pivot bracket. Follow the directions above to attach the seat.

### Quick Adjustment Seat

- Remove the two bolts from the bottom of the seat and remove the packing straps. Replace the bolts. Line up plastic seat spacers with the slots in seat pivot bracket. Slide seat in until front seat spacer engages the seat stop. To adjust the seat refer to the Adjustment Section. See Figure 4.

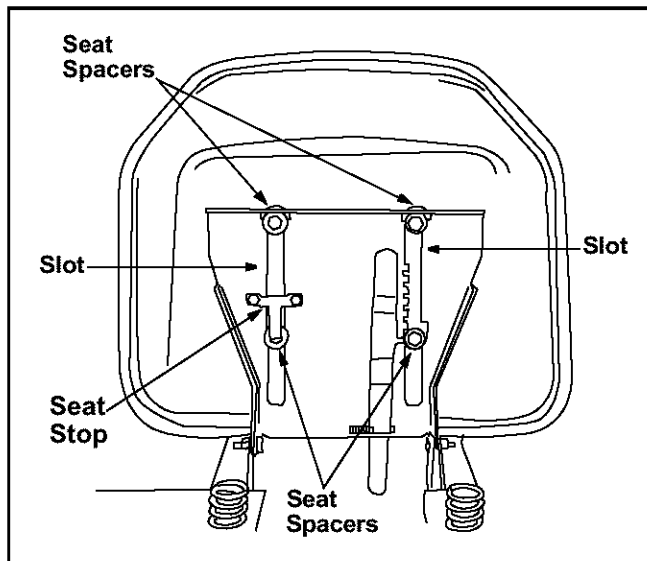

Figure 4

**NOTE:** If the seat was shipped in a box, line up plastic seat spacers with the slots in seat pivot bracket and slide seat in until front seat spacer engages seat stop.



**WARNING:** Before operating your unit, stand behind quick adjustment seat and pull back on seat, making sure seat is engaged in seat stop.

### Removing Shipping Brace



**WARNING:** The shipping brace, used for packaging purposes only, must be removed and discarded before operating your riding mower.



**WARNING:** Make sure the riding mower's engine is off, remove the ignition key, and set the parking brake before removing the shipping brace.

- Locate the shipping brace and accompanying warning tag on the right side of the mower, between the discharge chute and the cutting deck. See Figure 5.
- While holding the discharge chute with your left hand, remove the shipping brace with your right

hand by grasping it between your thumb and index finger and rotating it clockwise.

- Carefully allow the discharge chute to pivot downward.
- Discard the shipping brace and accompanying warning tag.

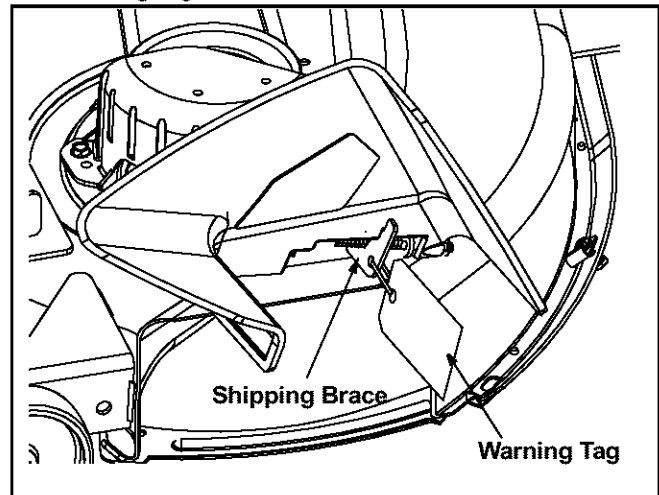

Figure 5

### Installing The Mulching Plug (If Equipped)

**NOTE:** Your mulching plug may already be installed on the deck.

Some lawn tractors come equipped with a mulch kit which incorporates special blades, already standard on all tractor, in a process of recirculating grass clippings repeatedly beneath the cutting deck. The ultra-fine clippings are then forced back into the lawn where they act as a natural fertilizer. Observe the following recommendations for the best results when mulching.

**NOTE:** The mulch kit is installed on models equipped with a 38" or 42-inch deck. It is packed separately (with an instruction sheet) in the crate on models equipped with a 46-inch deck.

- Never attempt to mulch if the lawn is damp. Wet grass tends to stick to the underside of the cutting deck preventing proper mulching of the clippings.
- Do NOT attempt to mulch more than 1/3 the total height of the grass or approximately 1-1/2 inches. Doing so will cause the clippings to clump up beneath the deck and not be mulched effectively.
- Maintain a slow ground speed to allow the grass clippings more time to effectively be mulched.
- Always position the throttle control lever in the FAST (rabbit) position and allow it to remain there while mowing. Failing to keep the engine at full throttle places strain on the tractor's engine and does not allow the blades to properly mulch grass.

**NOTE:** It is not necessary to remove the discharge chute to operate the mower with the mulch kit installed.

To operate the cutting deck without mulching, simply remove the mulch plug by unthreading the plastic wing nut which fastens it to the cutting deck. This will allow the clippings to discharge out the side. See Figure 6.

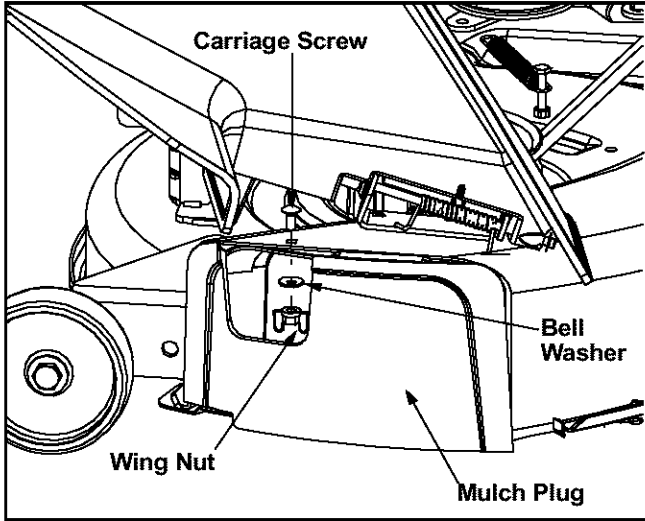

Figure 6

## Tire Pressure

- The tires on your unit may be over-inflated for shipping purposes. Reduce the tire pressure before operating the unit. Recommended operating tire pressure is approximately 10 p.s.i. Check sidewall of tire for maximum p.s.i.



**WARNING:** Maximum tire pressure under any circumstances is 30 p.s.i. Equal tire pressure should be maintained on all tires.

## Leveling the Deck

- With unit on hard, level surface, place the blades in a straight line, and measure the distance from the outside edge of the blade tips to the ground. If the distance varies, adjustment is needed.
- Remove the hairpin clip and flat washer from the bottom of the adjustable lift link on the left side of the deck. Locate the hairpin clip and the flat washer on the inside of the lift link.

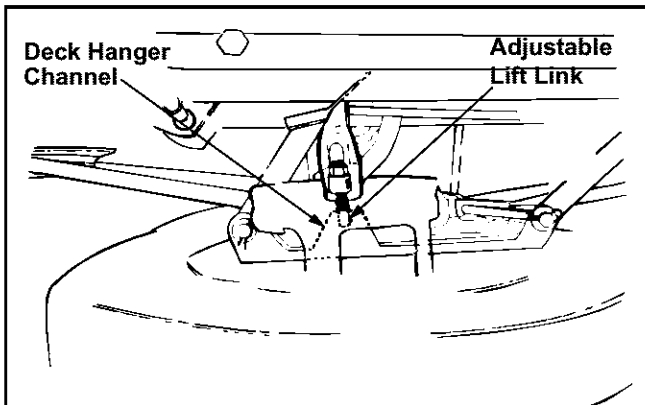

Figure 7

- Pull the adjustable lift link out of the deck hanger channel. Turn the adjustable lift link up or down as necessary to level the deck. Usually only one or two turns are needed. See Figure 7.
- Insert the end of the adjustable lift link into the hole in the deck hanger channel. Recheck the adjustment. Readjust if necessary.
- When the deck is levelled, secure end of adjustable lift link with flat washer and hairpin clip.

## Installing Battery

### Type A Battery

**NOTE:** If the battery is put into service after the expiration of the date shown on top of the battery, charge it for a minimum one hour at 6-10 amps.

- Lift the seat and remove the plastic cover from the negative terminal.
- Remove the hex bolt and nut from the negative (black) cable. Attach negative cable to the negative terminal with this bolt and nut.

### Type B Battery

- Lift the seat. Make sure both the negative (black) cable and the positive (red) cable are routed up through the battery compartment. See Figure 8.
- Replace the battery in the battery compartment as it was before. Make sure that the positive terminal is toward the front of the unit.

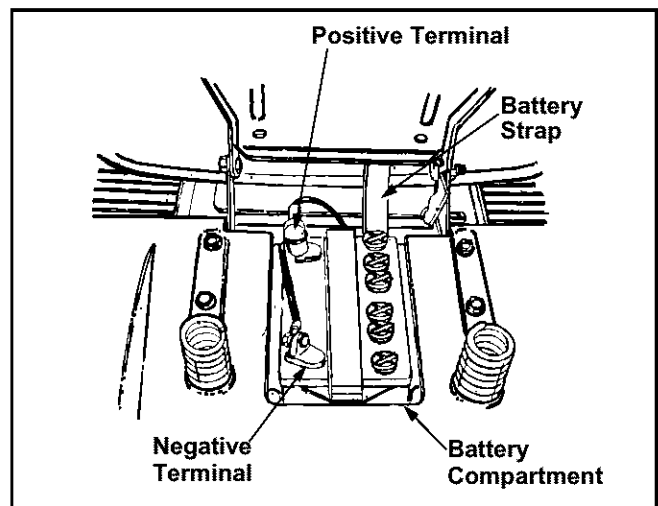

Figure 8

- Attach the positive (red) cable to the positive terminal of the battery. Secure with hex bolt and nut previously removed. Slide rubber boot down over the positive terminal.
- Remove the hex bolt and nut from the negative (black) cable. Attach negative cable to the negative terminal with this bolt and nut.
- Secure battery by hooking battery strap into slot in rear frame, under the fender. See Figure 9.

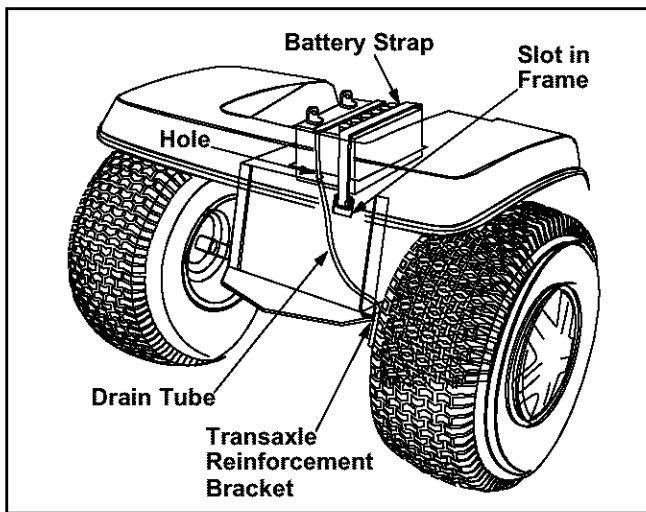

Figure 9

- Insert the drain tube down through the hole in the battery compartment and the hole in the transaxle reinforcement bracket located on the **right** side of the unit. See Figure 9. Be certain drain tube is routed away from the wheel rim.
- Trim excess end of drain tube if necessary (about 4" should extend past the bracket or cable tie).

## SECTION 4: KNOW YOUR LAWN TRACTOR

### Ignition Switch

The ignition switch is located on the dashboard. Start the engine by turning the key to the START position. When the engine is running, leave the key in the ON position. To stop the engine, turn the key to the OFF position. See Figure 10.



**WARNING:** Remove the key from the tractor, when the tractor is not in use, to prevent accidental starting.

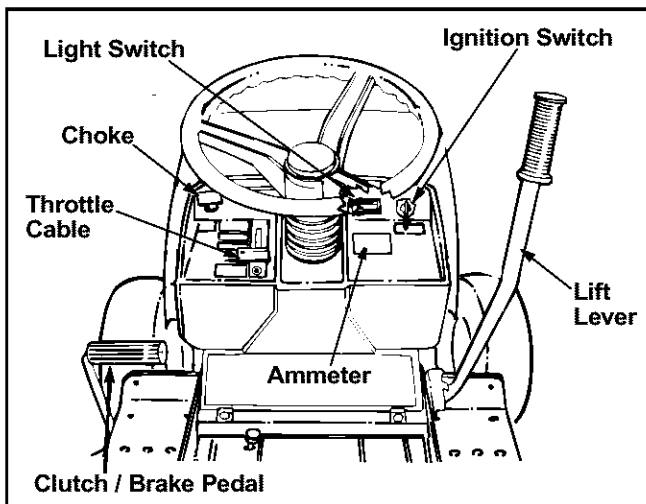

Figure 10

### Choke Control

The choke control is located on the dashboard and is operated manually. Details for the choke operation are covered in the separate engine manual packed with your unit. See Figure 10.

### Throttle Control

The throttle control is located on the dashboard and is

used to regulate the engine speed. To get maximum efficiency in cutting grass, the throttle should be in the FAST position when operating the tractor.

### Clutch-Brake Pedal

The clutch-brake pedal is located on the left side of the tractor. Depressing the pedal returns the drive unit to neutral (N) and applies the brake. The clutch-brake pedal must be depressed to start the engine.

### Hydrostatic Control Lever

The hydrostatic control lever is located on top of the fender on the right side of the tractor. This single control lever, connected to the hydrostatic transmission, controls both the speed and direction of the tractor. Infinite speed control is achieved by moving the control lever forward or backward. The farther forward or backward you move the control lever, the faster you will travel. Pulling the control lever into neutral (N) area will stop the tractor. See Figure 11.

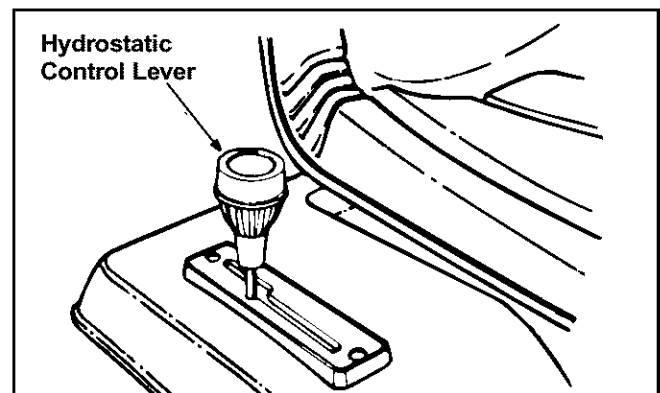

Figure 11

### Parking Brake

To set the parking brake, depress the clutch-brake pedal, pull up the parking brake knob and release the

clutch-brake pedal. It will stay in the raised position. To release the parking brake, depress and release the clutch-brake pedal while pushing down on the parking brake knob. The parking brake must be set if the operator leaves the seat with the engine running. See Figure 12.

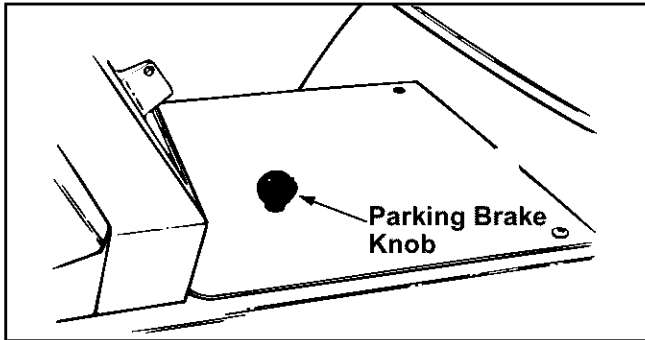

Figure 12

### Relief Valve

A hydrostatic relief valve is provided so the unit can be moved without the engine running. The lever which operates the relief valve is located in the of the tractor between the wheels. See Figure 13.

To operate the relief valve, place the hydrostatic control lever in neutral and release the parking brake. Move the lever from the lock position into the slot to relieve the hydraulic pump. Make sure to release the lever to the lock position before operating the engine.

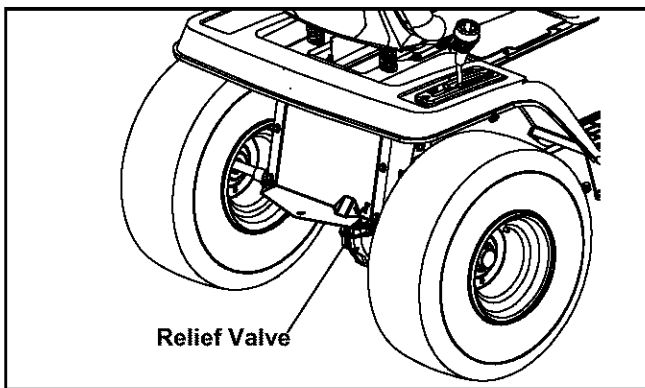

Figure 13

### Lift Lever

The lift lever is used to raise and lower the cutting deck and to engage and disengage the blades. Pulling it all the way back and locking it disengages the blades. See Figure 14.

**NOTE:** The lift lever *must* be in the **BLADES STOP** position when starting the engine, when shifting into reverse and if the operator leaves the seat.

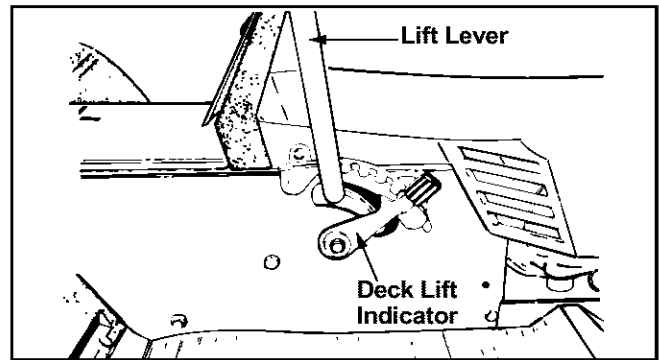

Figure 14

## Optional Features

**NOTE:** The controls listed below are optional features and many tractor models may not be equipped with one or more of these. Please use information pertinent to your lawn tractor.

### Indicator Lights

If your unit is equipped with indicator lights, two or three indicator lights are located in the dash panel. If a light illuminates when attempting to start the unit, proceed as follows.

Clutch: Depress the clutch pedal.

PTO: Place lift lever in the Blades Stop position.

Oil (Vanguard Twin and Intek Twin Engines Only).

Check the crankcase oil level and add oil as required.

### Deck Lift Indicator

The deck lift indicator (if so equipped) marks the position being used for the lift lever. Select the lift lever position desired, press the indicator lever outward, move it to the position immediately below the lift lever and release the indicator lever.

### Light Switch

The head lamps are operated by pushing the light switch located on the dashboard. The head lamps will only operate when the engine is running.

### Ammeter

The ammeter registers the rate of battery charge or discharge. While the engine starts, the ammeter will register on the discharging side. It should register on the opposite side (charging) when the engine is running fast and the battery is not yet completely charged. With a fully charged battery or with the engine idling, the ammeter will not show a charge.

## SECTION 5: OPERATING YOUR LAWN TRACTOR



**WARNING:** Go up and down slopes, not across. Avoid sudden turns. Do not operate the unit where it could slip or tip over. If the tractor stops while going uphill, stop the blade(s) and reverse down the hill slowly.

Do not mow when children or others are around. Never carry children. Look down and behind the tractor before and while backing. Keep the pathway of the tractor free of obstructions.

Keep safety devices like guards, shields and switches in place and fully functional.

Make sure that the blade(s) and the engine have stopped completely before you put hands or feet near the blade(s).

### Gas And Oil Fill-Up

- Check the oil level and add if necessary. Service the engine with gasoline as instructed in the separate engine manual packed with your tractor. Read instructions carefully.

**IMPORTANT:** Your tractor is shipped with oil; however you **must** check the oil level always before operating. Be careful not to overfill.

### Starting Engine

**IMPORTANT:** This unit is equipped with a **safety interlock system** for your protection. The purpose of the safety interlock system is to prevent the engine from cranking or starting unless the clutch-brake pedal is depressed and the lift lever is in the BLADES STOP position. In addition, the lift lever must be in the BLADES STOP position when the unit is put into reverse or the engine will shut off. If the operator leaves the seat with the lift lever engaged and/or without setting the parking brake, the engine will shut off.



**WARNING:** Do not operate the tractor if the interlock system is malfunctioning because it is a safety device, designed for protection.

- Place the lift lever in the BLADES STOP position.
- Depress clutch-brake pedal and set parking brake.
- Place the hydrostatic control lever in the NEUTRAL (N) position.
- Set the throttle control in the FAST position.
- Pull out the choke control (a warm engine may not require choking).

- Turn the ignition key to the right to the START position. After the engine starts, release the key. It will return to the ON position.

**NOTE:** Protect the starter's life by using short starting cycles of several seconds. Cranking more than 15 seconds per minute can damage the starter motor.

- Push choke knob gradually. Move the throttle control to desired engine speed.

### Stopping Engine

- Turn the ignition key to the left to the OFF position. Remove the key to prevent accidental starting.

**IMPORTANT:** If you strike a foreign object, stop the engine. Remove wire from spark plug, thoroughly inspect the unit for any damage, and repair the damage before restarting and operating the mower.



**WARNING:** Before leaving the operator's position, disengage blade(s), place shift lever in neutral, engage brake lock, shut off engine and remove key.

### Operating Lawn Tractor

- Move throttle control to full throttle to prevent strain on the engine and to operate the cutting blades.
- Depress the clutch-brake pedal while pushing down on the parking brake knob so the parking brake is released, and then release the clutch-brake pedal.
- Place the hydrostatic control lever in either the FORWARD or the REVERSE position. The farther forward you move the lever, the faster you will travel. Look to the rear before reversing.
- To stop the lawn tractor, pull the hydrostatic control lever into NEUTRAL (N) or depress the clutch-brake pedal.
- Be sure that the lawn is clear of stones, sticks, wire, or other objects which could damage lawn tractor or engine. For best results and to insure more even grass distribution, do not mow when the lawn is excessively wet.
- **Before leaving the operator's position for any reason,** disengage the blades, place the hydrostatic control lever in neutral, engage the parking brake, shut engine off and remove the key.
- Follow the same procedure when stopping the unit to empty a grass bag. This procedure will also eliminate "browning" of the grass, which is caused by exposure to hot exhaust gases from engine.

## Setting Cutting Height

- Select the position for the lift lever which gives the desired cutting height. Move the deck lift indicator (if so equipped) so that the lift lever can be returned to the same position after it is raised.
- Move the deck wheels (if so equipped) to the hole location so the wheels are 1/4 inch above the ground. All wheels must be placed in the same relative position.

## Grass Collector

Grass Collector Model OEM-190-063 is available as optional equipment for lawn tractors with 38" and 42" decks. Grass Collector Model OEM-190-103 is available for lawn tractors with 46" decks.

**NOTE:** Under normal usage bag material is subject to wear and should be checked periodically. Be sure to use only factory authorized replacement bag.



**WARNING:** The mower should not be operated without the entire grass catcher or chute deflector firmly installed in place.

## SECTION 6: MAKING ADJUSTMENTS



**WARNING:** Disconnect spark plug wires and ground against the engine before performing any adjustments, repairs or maintenance.

### Manual Adjustment Seat

- To adjust the position of the seat, loosen the four screws on the bottom of the seat. Slide the seat forward or backward as desired. Retighten the four screws. Refer to Figure 3.

### Quick Adjustment Seat

- To adjust the position of the seat, move the seat adjustment lever (located under the seat) to the left and slide the seat forward or backwards. Make sure seat is locked into one of the six positions before operating the lawn tractor. See Figure 15.

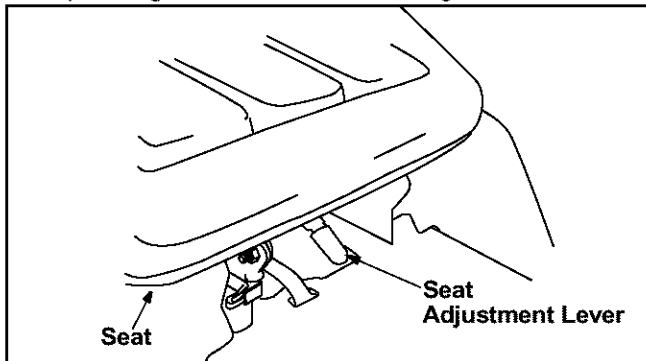

Figure 15

### Hydrostatic Neutral Control

The hydrostatic transmission control is in correct adjustment when the tractor does not move with the engine running, the clutch engaged and the hydrostatic control lever in the neutral position. If adjustment is necessary, follow these steps:

- Raise both rear wheels off the ground by placing blocks under the rear frame.

- Remove the transmission panel by removing the parking brake knob and truss machine screws.
- Loosen the hex jam nut on the speed selector adjusting rod. See Figure 16.
- Loosen the hex nut on the scissor mounting bracket. See Figure 16.

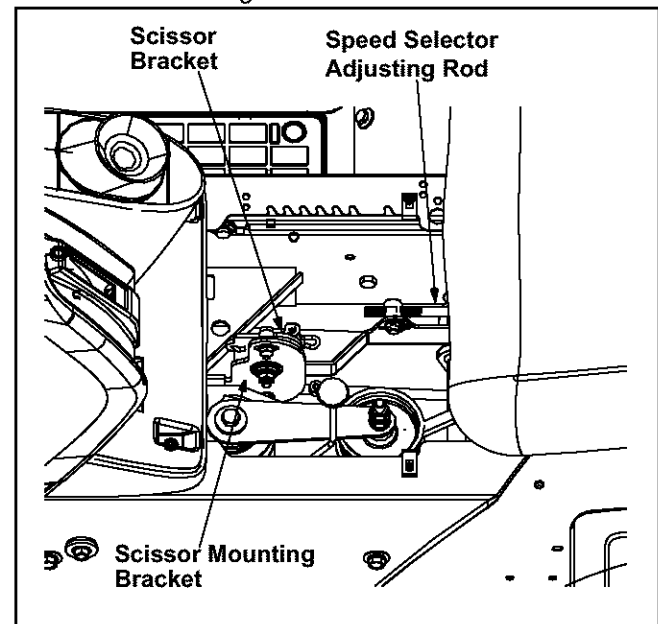

Figure 16

- Start the engine and run at full throttle.
- Move hydrostatic control lever until you find neutral. At this position, rear wheels will not rotate in either direction.
- Depress the clutch-brake pedal until the scissor brackets come together.
- Shut off the engine.
- Tighten hex nut on the scissor mounting bracket.
- Thread the speed selector rod in or out of the ferrule until the hydrostatic control lever lines up in neutral position on the speed control index bracket.
- Tighten hex jam nut against the ferrule.

- Replace the transmission panel and parking brake knob.
- Remove the blocks from under the frame and test the operation of the tractor.

## Deck Leveling

If the tractor is cutting grass unevenly, level the deck following instructions in the Assembly Section.

## Cutting Deck Engagement

The cutting deck engagement may be adjusted to ensure that deck is disengaged when lift lever is in BLADES STOP position. Correct adjustment as follows.

- With the engine off, place the lift lever in the highest cutting position (first position).
- Remove the cotter pin and flat washer which secure the disengagement rod to the stabilizer shaft assembly. See Figure 17.

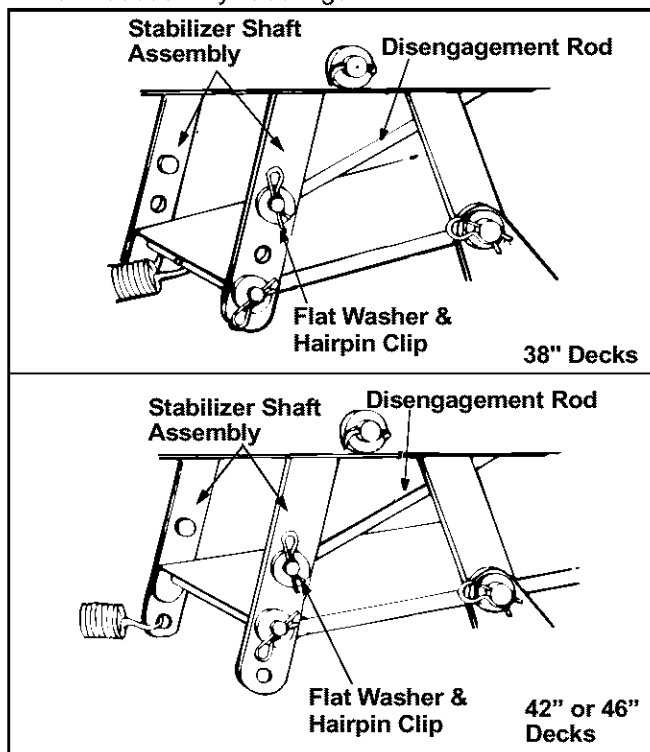

Figure 17

- Shorten the rod by threading it in, until the ferrule is against the back of the slot in the lift shaft assembly, and the rod lines up with the hole in the stabilizer shaft.
- For more belt tension, the disengagement rod must be lengthened. To decrease belt tension the disengagement rod must be shortened.
- Check the adjustment by placing the lift lever in the BLADES STOP position. The deck should move up and forward, allowing the belt to become loose. Start and test for disengagement. Repeat procedure as necessary.

## Brake Adjustment



**WARNING:** Do not have the engine running when you adjust the brake.

The brake is located by the right rear wheel inside the frame. The brake has been set at the factory to the proper clearance. During normal operation of this machine, the brakes are subject to wear and will require periodic examination and adjustment.

- To adjust the brake, adjust the nut so the brake starts to engage when the brake lever is 1/4" to 5/16" away from the axle housing. See Figure 18.

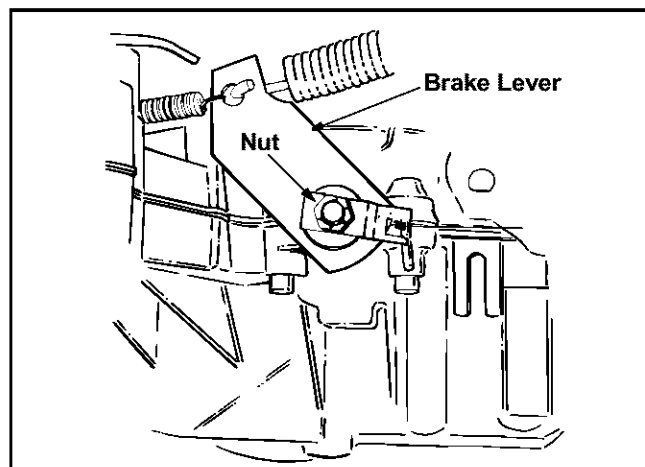

Figure 18

## Wheel Adjustment

(Units with Adjustable Tie Rod)

The caster (forward slant of the king pin) and the camber (tilt of the wheels out at the top) require no adjustment. Automotive steering principles have been used to determine the caster and camber on the tractor. The front wheels should toe-in between 1/16- 5/16 inch. To adjust the toe-in, follow these steps.

- Remove the hex nut and the lock washer, and drop the end of the tie rod from the axle bracket. See Figure 19.
- Loosen the hex jam nut on tie rod.
- Adjust the tie rod assembly for correct toe-in. Dimension B should be approximately 1/16"-5/16" less than Dimension A. See Figure 19.
- To increase Dimension "B," screw tie rod into tie rod end. To decrease Dimension "B," unscrew tie rod from tie rod end. Reassemble tie rod. Check dimensions. Readjust if necessary.



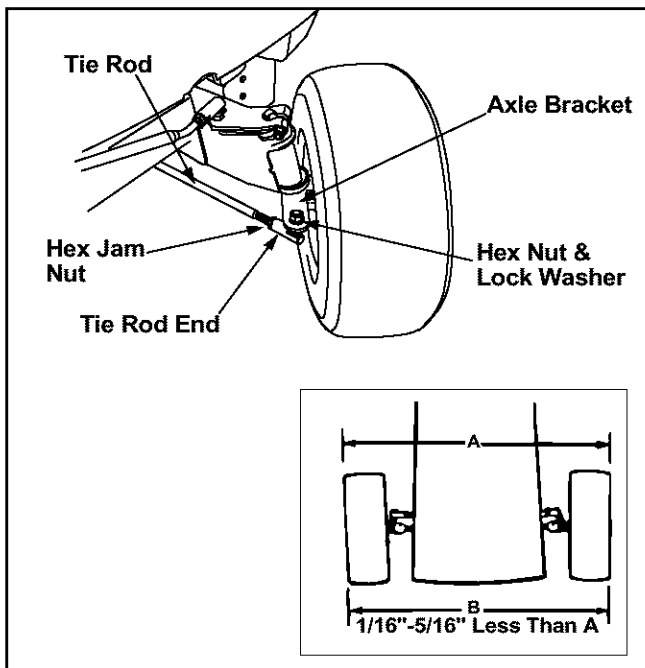

Figure 19

## Carburetor



**WARNING:** If any adjustments are made to the engine while the engine is running (e.g. carburetor), disengage all clutches and blades. Keep clear of all moving parts. Be careful of heated surfaces and muffler.

Minor carburetor adjustments may be required to compensate for differences in fuel, temperature, altitude and load. Refer to separate engine manual for carburetor adjustment information.

**NOTE:** A dirty air cleaner will cause an engine to run rough. Be certain air cleaner is clean and attached to the carburetor before adjusting carburetor.

## SECTION 7: MAINTAINING YOUR LAWN TRACTOR

### Battery Care

#### Type "A" Battery

Type "A" batteries are maintenance-free.

#### Type "B" Battery

- Check fluid level inside each cell of the battery every two weeks and before and after charging. Always keep level between maximum and minimum fill level.
- Add only distilled water. Never add additional acid or any other chemicals to the battery after initial activation.

**NOTE:** After operating the lawn tractor for a long period of time, check the fluid level in the battery as it can overheat and lose fluid.

- The engine is equipped with an alternator which charges battery when tractor is operated. Under normal conditions, the battery only needs to be charged before, during and after off-season storage.
- **To charge the battery:**  
Battery P/N 725-1705D—Charge at 2-3 amps for one hour. Battery P/N 725-1707D, 725-0453G, and 725-1750—Charge at 6 amps for one hour.



**WARNING:** When removing or installing the battery, follow these instructions to prevent the screwdriver from shorting against the frame.

- **Removing the Battery:** Disconnect negative cable first, then positive cable.
- **Installing the Battery:** Connect positive cable first, then negative cable.

#### Jump Starting

- First, connect end of one jumper cable to the positive terminal of the good battery, then the other end to the positive terminal of the dead battery.
- Connect the other jumper cable to the negative terminal of the good battery, then to the frame of the unit with the dead battery.



**WARNING:** Failure to use this procedure could cause sparking, and the gas in either battery could explode.

#### Cleaning Battery

- Clean the battery by removing it from the unit and washing with a baking soda and water solution. If necessary, scrape the battery terminals with a wire brush to remove deposits. Coat terminals and exposed wiring with grease or petroleum jelly to prevent corrosion.

#### Battery Failures

Some common causes for battery failure are: incorrect initial activation, lack of water, adding chemicals other than water after initial activation, undercharging, overcharging, corroded connections, freezing. These failures do not constitute warranty.

## Lubrication



**WARNING:** Always stop engine and disconnect spark plug wire before cleaning, lubricating or doing any kind of work on lawn tractor.

### Pivot Points

- Lubricate all pivot points with light oil once a season.

### Ball Joints

- The ball joints and drag link ends are permanently lubricated and do not need periodic lubrication.

### Hydrostatic Transmission

The hydrostatic transmission is filled at the factory and does not require checking. If repairs are needed, contact your local service dealer. The hydrostatic transmission contains approximately 2.5 quarts of SAE 20W50 oil.

### Steering Gears

- Lubricate teeth of steering gears with automotive multi-purpose grease after every 25 hours of operation or once a season. See Figure 20.

### Steering Shaft

- Lubricate steering shaft at least once a season with light oil. See Figure 20.

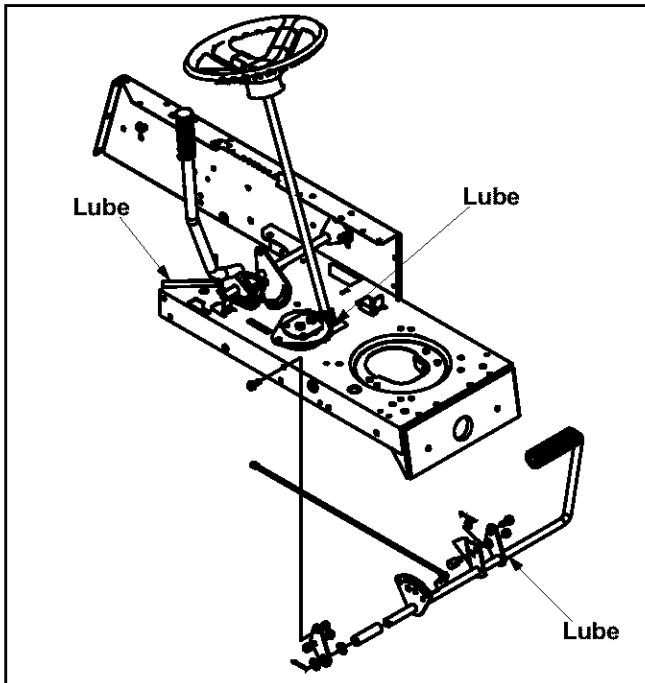

Figure 20

### Linkage

- Once a season lubricate all the pivot points on the clutch, brake and lift linkage with SAE 30 engine oil.
- The front wheels may be provided with optional grease fittings. The rear wheels must be removed

from the axle for lubrication. Lubricate at least once a season with automotive multi-purpose grease.

## Cutting Blades

### Removing Blade



**WARNING:** Be sure to disconnect and ground the spark plug wire(s) and remove ignition key before working on the cutting blade to prevent accidental engine starting. Protect hands by using heavy gloves or a rag to grasp the cutting blades.

- Remove the hex flange nut which holds the blade to the blade spindle. See Figure 21.
- Remove the blade from the spindle.

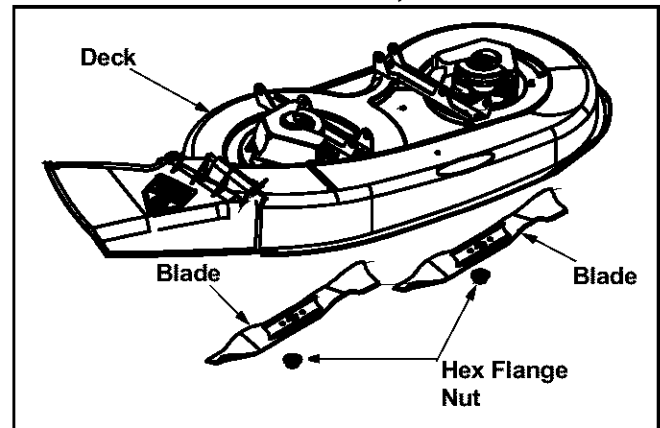

Figure 21

### Sharpening Blade

- Remove the cutting blades by following the directions in the preceding section.
- When sharpening the blades, follow the original angle of grind as a guide. It is extremely important that each cutting edge receives an equal amount of grinding to prevent an unbalanced blade. An unbalanced blade will cause excessive vibration when rotating at high speeds, may damage the tractor and/or could break, causing personal injury.

### Balancing Blade

- The blade can be tested for balance by balancing it on a round shaft screwdriver. Remove metal from the heavy side until it balances evenly.

### Reassembly

- When replacing blades, be sure to install the blade with the side of the blade marked "Bottom" (or with part number) facing the ground when the tractor is in the operating position. Carefully align "star" on blade with "star" on spindle. Secure with flange nut.

### Blade Mounting Torque

Hex Flange Nut: 840 in. lb. min., 1080 in. lb. max.

- All nuts and bolts must be checked periodically for correct tightness.

## Belt Replacement



**WARNING:** Disconnect the spark plug wire(s) and ground it against the engine. Block the wheels of the unit.

**NOTE:** Figure 22 and Figure 26 are shown with the unit tipped up for clarity. It is not necessary to tip the unit to remove the belts. However, for convenience, if you decide to tip it, remove the battery from the unit first.

- To prevent gasoline leakage, drain the gasoline, or remove the fuel tank cap. Place a thin piece of plastic over the neck of the fuel tank and screw on the cap. Be certain to remove the plastic when finished changing the belts. Block unit securely.

### Deck Belt (38" and 42" Decks)

- Place the lift lever in the engaged (all the way forward) position.
- Disconnect the spring which is attached to a bracket on the transaxle, inside the right rear wheel. Use a spring puller or other suitable tool.

**NOTE:** When reassembling, make certain belt keeper pins are assembled in the same locations from which they were removed. See Figure 22.

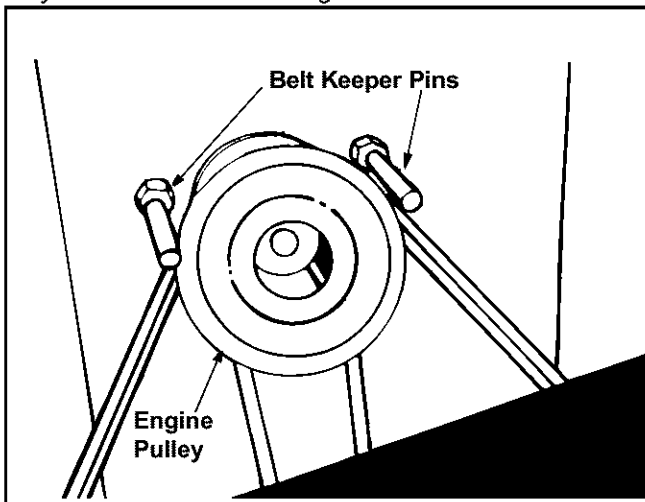

Figure 22

- Place the lift lever in the BLADES STOP position.
- Remove the belt keeper pins from the lower frame.
- Unhook the deck belt from the engine pulley.
- Place the lift lever in the engaged (all the way forward) position.
- Disconnect the stabilizer plate from the stabilizer shaft assembly by removing the hairpin clips and flat washers and sliding out the rod.
- Disconnect the six deck links by removing the hairpin clips and flat washers.
- Place the lift lever in the BLADES STOP position.
- Slide the deck from beneath the lawn tractor.
- Remove the belt guards at each deck pulley by removing the self-tapping screws. See Figure 23.

- Remove and replace the belt, reassemble following the instructions in reverse order.

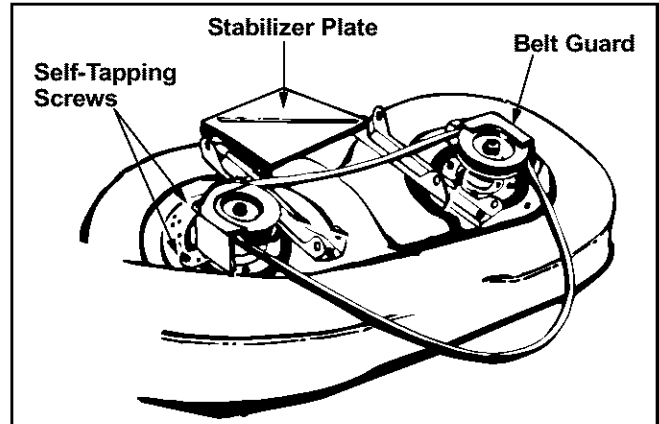

Figure 23

### Deck Belts (46" Deck)

- Place the lift lever all the way forward.
- Disconnect the spring which is attached to a bracket on the transaxle inside the right rear wheel. Use a spring puller or other suitable tool.

**NOTE:** When reassembling, make certain belt keeper pins are assembled in the same locations from which they were removed. See Figure 22.

- Place the lift lever in the BLADES STOP position.
- Remove the belt keeper pins from the lower frame. Refer to Figure 22.
- Unhook the deck belt from the engine pulley.
- Place the lift lever in the engaged (all the way forward) position.

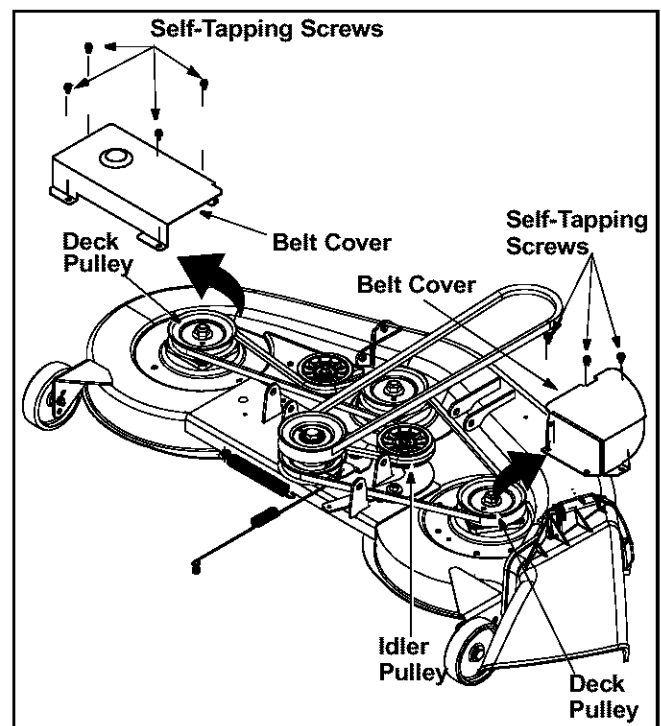

Figure 24

- Disconnect the stabilizer plate from the stabilizer shaft assembly by removing the hairpin clips and the flat washers and sliding out the rod. Refer to Figure 17.
- Disconnect the six deck links by removing the hairpin clips and flat washers.
- Place the lift lever in the BLADES STOP position.
- Slide the deck from beneath the lawn tractor.
- Remove the top deck drive belt by lifting up on the stabilizer plate, and slipping belt off the pulley.
- Remove the belt cover at the two outside deck pulleys, by removing the self-tapping screws. See Figure 24.
- Release the tension on the spring loaded idler by pushing the idler toward the rear of the deck.
- Remove the belt from around the idler pulleys, and remove from the three deck pulleys. See Figure 24.
- Reassemble new belts, following instructions in reverse order.

### Drive Belt

- Depress the clutch pedal and set the parking brake.
- Remove the deck from the lawn tractor.
- Raise and block the front wheels of the lawn tractor so you can work under it.
- Remove the transmission panel by removing the parking brake knob and truss machine screws.
- Raise the seat. Disconnect the battery cables. Remove the battery from the unit.
- Disconnect the idler pulley spring which is attached to a bracket on the frame, inside the left rear wheel. Use a spring puller or other suitable tool. See Figure 25.

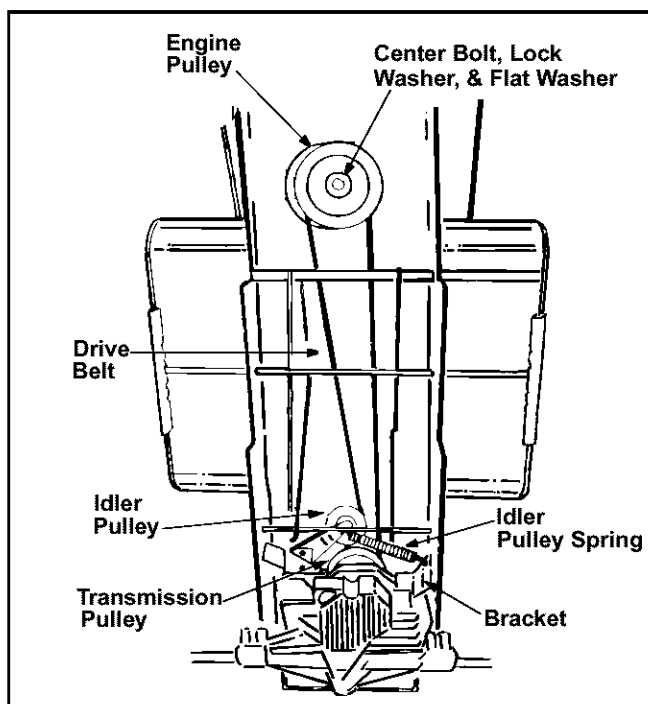

Figure 25

- Remove the three self-tapping screws from the cooling fan. Remove the fan.
- Remove the center bolt, lock washer and flat washer, and let the engine pulley drop down so the belt is past the belt guards. See Figure 25.
- Roll the belt off of top sheave of engine pulley, onto the pulley hub.
- Remove the belt from the transmission pulley and engine pulley, and remove from the unit.
- Reassemble using a new belt, following instructions in reverse order.

## Hydrostatic Transmission Cooling

The hydrostatic transmission is cooled by the oil, fan and fins. If the hydrostatic transmission runs hot, check to see if the fan is in operating condition, the oil level is correct and the fins are clean.

**NOTE:** *DO NOT use high pressure water spray or steam to clean the hydrostatic transmission.*



**WARNING:** Disconnect spark plug wire and ground against engine before performing any adjustments, repairs or maintenance work on the tractor.

## Fuel Filter

- Your unit is equipped with a replaceable in-line fuel filter. Replace filter whenever contamination or discoloration is noticed. Order replacement filter through your authorized engine service dealer.

## Cleaning Engine & Deck

- Any fuel or oil spilled on the machine should be wiped off promptly. Grass, leaves, and other dirt must not be left to accumulate around the cooling fins of the engine or on any part of the machine.
- Clean the underside of the deck after each mowing.

## Engine

- Refer to the separate engine manual for engine maintenance instructions.
- Service **air cleaner** every 10 hours under normal conditions. Clean every few hours under extremely dusty conditions. To service the air cleaner, refer to the separate engine manual packed with your unit.
- The **spark plug(s)** should be cleaned and the gap reset once a season. Spark plug replacement is recommended at the start of each mowing season; check engine manual for correct plug type and gap specifications.
- Maintain **engine oil** as instructed in the separate engine manual packed with your unit. Read and follow instructions carefully.

## Oil Drain Sleeve (If equipped)

- Your lawn tractor may have a plastic oil drain sleeve packed with the loose parts for your convenience in draining oil from the crankcase. To drain the oil, snap small end of oil drain sleeve onto oil sump. Remove drain plug and drain oil into a suitable container. See Figure 26.

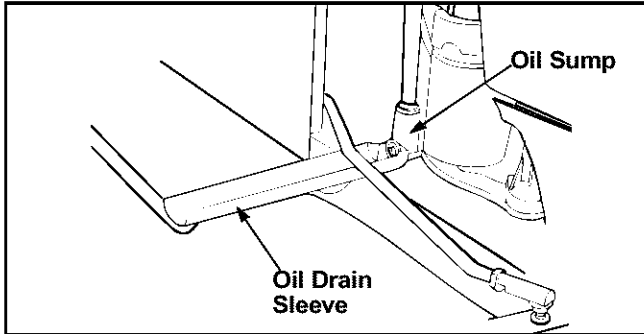

Figure 26

## Oil Drain Valve (If equipped)

- Your lawn tractor may have a valve installed on the engine for draining oil from the crankcase. To drain the oil, insert the 12" hose (shipped loose with your unit) over the end of the valve. Place the other end in a suitable container. Push in black cap, rotate counter-clockwise and pull valve open. When oil is completely drained, push top of valve in and rotate clockwise to close. See Figure 27.

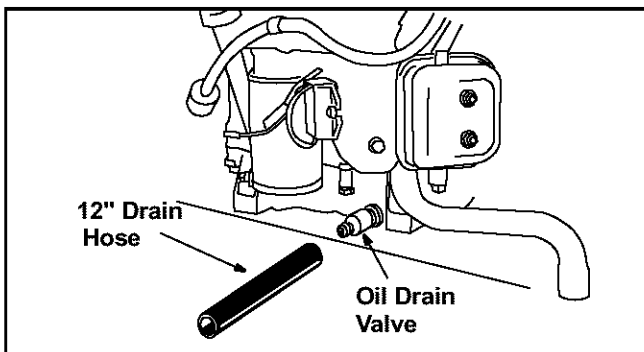

Figure 27

## Tire Pressure

Recommended operating tire pressure is approximately 10 p.s.i. Maximum tire pressure under any circumstance is 30 p.s.i. Equal tire pressure should be maintained on all tires.

- When installing a tire to the rim, be certain rim is clean and free of rust. Lubricate both the tire and rim generously. Never inflate to over 30 p.s.i. to seat beads.



**WARNING:** Excessive pressure (over 30 p.s.i.) when seating beads may cause tire/rim assembly to burst with force sufficient to cause serious injury.

## OFF-SEASON STORAGE

If the tractor will remain unused for more than 30 days, prepare it for storage as follows.

- Clean the engine and the entire unit thoroughly.
- Lubricate all pivot and linkage points. Wipe the tractor with an oiled rag to protect the surfaces.
- Refer to the engine manual for correct engine storage instructions. The engine must be completely drained of fuel to prevent gum deposits from forming on essential carburetor parts, fuel lines and fuel tanks.
- If your tractor is equipped with the B type battery, charge it fully. The battery loses some of its charge each day when the unit is not used. NEVER store battery without a full charge. Recharge battery before returning to service or every two months, whichever occurs first.
- When storing unit for extended periods, disconnect battery cables. Removing battery from unit is recommended.
- Store unit in a clean, dry area. Do not store next to corrosive materials, such as fertilizer.

**NOTE:** When storing any type of power equipment in an unventilated or metal storage shed, care should be taken to rustproof the equipment. Using a light oil or silicone, coat the equipment, especially any chains, springs, bearings and cables.

---

## SECTION 8: OPTIONAL EQUIPMENT

Description	Model No.
40" Two Stage Snow Thrower	OEM-190-621
42" Dozer Blade	OEM-190-620
Mulch Kit for 38"/42" Deck	OEM-190-112
Mulch Kit for 46" Deck	OEM-190-118
Twin Bag Grass Collector for 38"/42" Side Discharge Decks	OEM-190-063
Twin Bag Grass Collector for 46" Side Discharge Decks	OEM-190-103
Front Counterweight	OEM-190-745
Tire Chains—	
18 x 8.5	OEM-190-754
18 x 9.5	OEM-190-657
20 x 8	OEM-190-658
20 x 10	OEM-190-915
31 Lb. Wheel Weights	OEM-190-215
Gang Reel (Set of three)	45-0195*
38" Lawn Sweeper	45-0222*
Heavy Duty Dump Cart	45-0171*
Tine De-Thatcher	45-0186*

**NOTE:** *These lawn tractors are not designed for ground-engaging equipment (tillers, plows, etc).*

\*Available through your local dealer or from Agri-Fab Inc., 303 W. Raymond Street, Sullivan, Illinois 61951.

## SECTION 9: TROUBLE SHOOTING GUIDE

Trouble	Possible Cause(s)	Corrective Action
Engine will not crank	<ol style="list-style-type: none"> <li>Safety switch button not depressed.</li> <li>Battery installed incorrectly.</li> <li>Battery is dead or weak.</li> <li>Blown fuse or circuit breaker.</li> <li>Engine ground wire loose.</li> </ol>	<ol style="list-style-type: none"> <li>There are two switches in the starting circuit of your unit: the clutch pedal switch and the deck lift lever switch. Make certain the actuator is fully depressing the buttons on each switch.</li> <li>The battery must be installed with negative terminal attached to black ground wire. Negative terminal is identified at the post by "NEG", "N" or "-". The positive terminal, identified by "POS", "P" or "+", must be attached to the big red wire which goes to the solenoid. All batteries are to be fully charged before installing. Refer to "Quick Start" battery guide that came with the operator's manual.</li> <li>Check fluid level in battery. If fluid is low, fill to just below split rings with water. Charge with 6 AMP charger until fully charged.</li> <li>Refer to operator's manual for fuse box location. Replace fuse with automotive type fuse. Fuses seldom fail without a reason. The problem must be corrected. Check for loose connections in the fuse holder. Replace fuse holder if necessary. A dead short may be in the cranking or charging circuit where the insulation may have rubbed through and exposed the bare wire. Replace the wire or repair with electrician's tape if the wire strands have not been damaged.</li> </ol> <p><b>NOTE:</b> Note: Look for a wire pinched between body panels, burned by the exhaust pipe or muffler or rubbed against a moving part.</p> <ol style="list-style-type: none"> <li>Engine should have a black ground wire running from engine to frame or mounting bolt.</li> </ol>
Engine cranks but will not start	<ol style="list-style-type: none"> <li>Throttle or choke not in starting position.</li> <li>No fuel to the carburetor.</li> <li>No spark to spark plug. Spark plug lead disconnected.</li> <li>Faulty spark plug.</li> <li>Dirty air cleaner.</li> </ol>	<ol style="list-style-type: none"> <li>Check operator's manual for correct position for throttle control and choke for starting.</li> <li> <ol style="list-style-type: none"> <li>Gasoline tank empty. Fill.</li> <li>Fuel line or in-line fuel filter plugged. Remove and clean fuel line. Replace filter.</li> </ol> </li> <li>Connect lead. Hold spark plug lead away from engine block about 1/8". Crank engine. There should be a spark. If not, have engine repaired at authorized engine service dealer.</li> <li>To test, remove spark plug. Attach spark plug lead to spark plug. Ground the spark plug body against the engine block. Crank the engine. The spark plug should fire at the electrode. Replace if it does not.</li> <li>If the air cleaner is dirty, the engine may not start. Refer to the engine manual packed with your unit.</li> </ol>
Excessive vibration	<ol style="list-style-type: none"> <li>Bent or damaged blade.</li> </ol>	<ol style="list-style-type: none"> <li>Stop engine immediately. Check all pulleys, blade adapters, keys and bolts for tightness and spindle damage. Tighten or replace any damaged parts.</li> </ol>
Mower will not discharge grass and/or leaves uncut strips	<ol style="list-style-type: none"> <li>Engine speed low.</li> <li>Cutting height set too low.</li> <li>Blades short or dull.</li> </ol>	<ol style="list-style-type: none"> <li>Throttle must be set at full throttle.</li> <li>Use lower ground speed. The slower your ground speed, the better the quality of cut.</li> <li>Raise deck. Sharpen or replace blades (uncut strip problem only).</li> </ol>

**NOTE:** If the above steps fail to correct the problem, contact your local authorized service dealer for repair.

# MANUFACTURER'S LIMITED WARRANTY FOR:



The limited warranty set forth below is given by MTD PRODUCTS INC ("MTD") with respect to new merchandise purchased and used in the United States, its possessions and territories.

MTD warrants this product against defects in material and workmanship for a period of two (2) years commencing on the date of original purchase and will, at its option, repair or replace, free of charge, any part found to be defective in material or workmanship. This limited warranty shall only apply if this product has been operated and maintained in accordance with the Operator's Manual furnished with the product, and has not been subject to misuse, abuse, commercial use, neglect, accident, improper maintenance, alteration, vandalism, theft, fire, water or damage because of other peril or natural disaster. Damage resulting from the installation or use of any accessory or attachment not approved by MTD Products Inc. for use with the product(s) covered by this manual will void your warranty as to any resulting damages.

Normal wear parts or components thereof are subject to separate terms as follows: All normal wear part or component failures will be covered on the product for a period of 90 days regardless of cause. After 90 days, but within the two year period, normal wear part failures will be covered ONLY IF caused by defects in material or workmanship of OTHER component parts. Normal wear parts and components include, but are not limited to, belts, blades, blade adapters, grass bags, rider deck wheels, seats, snow thrower skid shoes, shave plates and tires. Batteries are covered by a 90-day limited replacement warranty.

**HOW TO OBTAIN SERVICE:** Warranty service is available, WITH PROOF OF PURCHASE THROUGH YOUR LOCAL AUTHORIZED SERVICE DEALER. To locate the dealer in your area, please check for a listing in the Yellow Pages or contact the Customer Service Department of MTD PRODUCTS INC by calling 1-800-800-7310 or writing to P.O. Box 368022, Cleveland, Ohio 44136-9722.

**This limited warranty does not provide coverage in the following cases:**

- a. The engine or component parts thereof. These items carry a separate manufacturer's warranty. Please refer to the applicable manufacturer's warranty on these items.
- b. Log splitter pumps, valves and cylinders have a separate one year warranty.

- c. Routine maintenance items such as lubricants, filters, blade sharpening and tune-ups, or adjustments such as brake adjustments, clutch adjustments or deck adjustments; and normal deterioration of the exterior finish due to use or exposure.
- d. MTD does not extend any warranty for products sold or exported outside of the United States of America, its possessions and territories, except those sold through MTD's authorized channels of export distribution.

**No implied warranty, including any implied warranty of merchantability or fitness for a particular purpose, applies after the applicable period of express written warranty above as to the parts as identified. No other express warranty or guaranty, whether written or oral, except as mentioned above, given by any person or entity, including a dealer or retailer, with respect to any product shall bind MTD. During the period of the Warranty, the exclusive remedy is repair or replacement of the product as set forth above.** (Some states do not allow limitations on how long an implied warranty lasts, so the above limitation may not apply to you.)

**The provisions as set forth in this Warranty provide the sole and exclusive remedy arising from the sales. MTD shall not be liable for incidental or consequential loss or damages including, without limitation, expenses incurred for substitute or replacement lawn care services, for transportation or for related expenses, or for rental expenses to temporarily replace a warranted product.** (Some states do not allow the exclusion or limitation of incidental or consequential damages, so the above exclusion or limitation may not apply to you.)

In no event shall recovery of any kind be greater than the amount of the purchase price of the product sold. Alteration of the safety features of the product shall void this Warranty. You assume the risk and liability for loss, damage, or injury to you and your property and/or to others and their property arising out of the use or misuse or inability to use the product.

This limited warranty shall not extend to anyone other than the original purchaser, original lessee or the person for whom it was purchased as a gift.

**How State Law Relates to this Warranty:** This limited warranty gives you specific legal rights, and you may also have other rights which vary from state to state.