

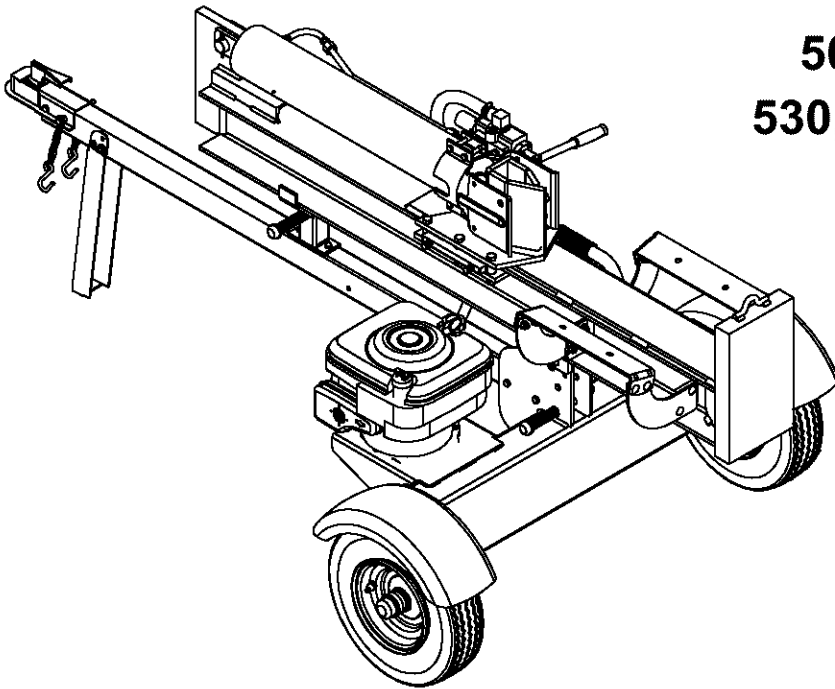

OPERATOR'S MANUAL

**Log Splitter
Vertical Shaft
Assembled
Model Series**

**500, 501, 510, 511
530, 550, 560, and 561**



IMPORTANT: READ SAFETY RULES AND INSTRUCTIONS CAREFULLY

Warning: This unit is equipped with an internal combustion engine and should not be used on or near any unimproved forest-covered, brush-covered or grass-covered land unless the engine's exhaust system is equipped with a spark arrester meeting applicable local or state laws (if any). If a spark arrester is used, it should be maintained in effective working order by the operator. In the State of California the above is required by law (Section 4442 of the California Public Resources Code). Other states may have similar laws. Federal laws apply on federal lands. A spark arrester for the muffler is available through your nearest engine authorized service dealer or contact the service department, P.O. Box 368022 Cleveland, Ohio 44136-9722.

MTD PRODUCTS INC. P.O. BOX 368022 CLEVELAND, OHIO 44136-9722

SECTION 1: IMPORTANT SAFE OPERATION PRACTICES



WARNING: This symbol points out important safety instructions which, if not followed, could endanger the personal safety and/or property of yourself and others. Read and follow all instructions in this manual before attempting to operate this machine. Failure to comply with these instructions may result in personal injury. When you see this symbol - **heed its warning.**

WARNING: Engine Exhaust, some of its constituents, and certain vehicle components contain or emit chemicals known to State of California to cause cancer and birth defects or other reproductive harm.

DANGER: This machine was built to be operated according to the rules for safe operation in this manual. As with any type of power equipment, carelessness or error on the part of the operator can result in serious injury. This machine is capable of amputating hands and feet and throwing objects. Failure to observe the following safety instructions could result in serious injury or death.

TRAINING

1. Read, understand, and follow all instructions on the machine and in the manual(s) before attempting to assemble and operate. Keep this manual in a safe place for future and regular reference and for ordering replacement parts.
2. Be familiar with all controls and their proper operation. Know how to stop the machine and disengage them quickly.
3. Never allow children under 14 years old to operate this machine. Children 14 years old and over should read and understand the operation instructions and safety rules in this manual and should be trained and supervised by a parent.
4. Never allow adults to operate this machine without proper instruction.
5. Many accidents occur when more than one person operates the machine. If a helper is assisting in loading logs, never activate the control until the helper is a minimum of 10 feet from the machine.
6. Keep bystanders, helpers, pets, and children at least 20 feet from the machine while it is in operation.
7. Never allow anyone to ride on this machine.
8. Never transport cargo on this machine.
9. Hydraulic log splitters develop high fluid pressures during operation. Fluid escaping through a pin hole opening can penetrate your skin and cause blood poisoning, gangrene, or death. Give attention to the following instructions at all times:
 - a. Do not check for leaks with your hand.
 - b. Do not operate machine with frayed, kinked, cracked, or damaged hoses, fitting, or tubing.
 - c. Stop the engine and relieve hydraulic system pressure before changing or adjusting fittings, hoses, tubing, or other system components.
 - d. Do not adjust the pressure settings of the pump or valve.
10. Leaks can be detected by passing cardboard or wood, while wearing protective gloves and safety glasses, over the suspected area. Look for discoloration of cardboard or wood.
11. If injured by escaping fluid, see a doctor immediately. Serious infection or reaction can develop if proper medical treatment is not administered immediately.
12. Keep the operator zone and adjacent area clear for safe, secure footing.
13. If your machine is equipped with an internal combustion engine and it is intended for use near any unimproved forest, brush, or grass covered land, the engine exhaust should be equipped with a spark arrester. Make sure you comply with applicable local, state, and federal codes. Take appropriate firefighting equipment with you.
14. This machine should be used for splitting wood only, do not use it for any other purpose.
15. Follow the instructions in the manual(s) provided with any attachment(s) for this machine.

PREPARATION

1. Always wear safety shoes or heavy boots.
2. Always wear safety glasses or safety goggles during operating this machine.
3. Never wear jewelry or loose clothing that might become entangled in moving or rotating parts of the machine.
4. Make sure this machine is on level surface before operating.
5. Always block the machine as required to prevent unintended movement, and lock in either the horizontal or vertical position.
6. Always operate this machine from the operator zone(s) specified in the manual.
7. Logs should be cut with square ends prior to splitting.
8. Use your log splitter in daylight or under good artificial light.

9. To avoid personal injury or property damage use extreme care in handling gasoline. Gasoline is extremely flammable and the vapors are explosive. Serious personal injury can occur when gasoline is spilled on yourself or your clothes which can ignite. Wash your skin and change immediately.
 - a. Use only an approved gasoline container.
 - b. Extinguish all cigarettes, cigars, pipes, and other sources of ignition.
 - c. Never fuel machine indoors.
 - d. Never remove gas cap or add fuel while the engine is hot or running.
 - e. Allow engine to cool at least two minutes before refueling.
 - f. Never overfill the fuel tank. Fill tank to no more than 1/2 inch below bottom of filler neck to provide space for fuel expansion.
 - g. Replace gasoline cap and tighten securely.
 - h. If gasoline is spilled, wipe it off the engine and equipment. move machine to another area. Wait 5 minutes before starting the engine.
 - i. Never store the machine or fuel container inside where there is an open flame, spark or pilot light as on a water heater, space heater, furnace, clothes dryer or other gas appliances.
 - j. Allow machine to cool at least 5 minutes before storing.
10. For logs which are not cut square, the least square end and the longest portion of the log should be placed toward the beam and wedge, and the square end placed toward the end plate.
11. When splitting in the vertical position, stabilize the log before moving the control. Split as follows:
 - a. Place log on the end plate and turn until it leans against the beam and is stable.
 - b. When splitting extra large or uneven logs, the log must be stabilized with wooden shims or split wood between the log and the end plate or ground.
12. Always keep fingers away from any cracks that open in the log while splitting. They can quickly close and pinch or amputate your fingers.
13. Keep your work area clean. Immediately remove split wood around the machine so that you do not stumble over it.
14. Never move this machine while the engine is running.
15. This machine should not be towed on any street, highway or public road without checking the existing federal, state, or local vehicle requirements. Any licensing or modifications such as taillights, etc., needed to comply, is the sole responsibility of the purchaser. If a "Statement of Origin" is required in your state, see your local dealer.
16. See the towing section in this manual for proper towing instructions once all federal, local, or state requirements are met.

OPERATION

1. Before starting this machine, review the "Safety Instructions". Failure to follow these rules may result in serious injury to the operator or bystanders.
2. Never leave this machine unattended with the engine running.
3. Do not operate machine while under the influence of alcohol, drugs, or medication.
4. Never allow anyone to operate this machine without proper instruction.
5. Always operate this machine with all safety equipment in place and working. Make sure all controls are properly adjusted for safe operation.
6. Do not change the engine governor settings or overspeed the engine. The governor controls the maximum safe operating speed of the engine.
7. When loading a log, always place your hands on the sides of the log, not on the ends, and never use your foot to help stabilize a log. Failure to do so, may result in crushed or amputated fingers, toes, hand, or foot.
8. Use only your hand to operate the controls.
9. Never attempt to split more than one log at a time unless the ram has fully extended and a second log is needed to complete the separation of the first log.

MAINTENANCE AND STORAGE

1. Stop the engine, disconnect the spark plug and ground it against the engine before cleaning, or inspecting the machine.
2. Stop the engine and relieve hydraulic system pressure before repairing or adjusting fittings, hoses, tubing, or other system components.
3. To prevent fires, clean debris and chaff from the engine and muffler areas. If the engine is equipped with a spark arrester muffler, clean and inspect it regularly according to manufacturers instructions. Replace if damaged.
4. Periodically check that all nuts and bolts, hose clamps, and hydraulic fittings are tight to be sure equipment is in safe working condition.
5. Check all safety guards and shields to be sure they are in the proper position. Never operate with safety guards, shields, or other protective features removed.
6. The pressure relief valve is preset at the factory. Do not adjust the valve.
7. Never attempt to move this machine over hilly or uneven terrain without a tow vehicle or adequate help.

8. For your safety, replace all damaged or worn parts immediately with original equipment manufacturer's (O.E.M.) parts only. "Use of parts which do not meet the original equipment specifications may lead to improper performance and compromise safety!"

9. Do not alter this machine in any manner, alterations such as attaching a rope or extension to the control lever, or adding to the width or height of the wedge may result in personal injury.



WARNING: - YOUR RESPONSIBILITY: Restrict the use of this power machine to persons who read, understand and follow the warnings and instructions in this manual and on the machine.

NOTE: Not all safety labels shown may apply to your log splitters.

WARNING - TO AVOID INJURY AND/OR PROPERTY DAMAGE

MOVING LOG SPLITTER BY HAND:

- Lock beam in horizontal position.
- Lock jack stand in down position.
- Do not attempt to move log splitter up or down a slope by hand

S30230

TOWING LOG SPLITTER:

- Lock beam in horizontal position.
- Attach coupler to Class I or higher hitch with 1-7/8" ball. Latch securely.
- Raise jack stand and latch securely in full up position.
- Attach safety chains to tow vehicle.
- Do not tow faster than 45 mph. High speed may cause loss of control.
- Check local, state and federal requirements before towing on any public road.

VERTICAL

OPERATOR'S INSTRUCTIONS

1. Place log splitter on flat dry solid ground.
2. Lock in either the Horizontal or Vertical position.
3. Set the engine throttle at maximum speed.
4. Place the log against the end plate.
5. Stabilize the log when needed on the sides. NEVER on the end between the log and the splitting wedge.
6. Only one adult should stabilize the log and operate the control.
7. Move the control handle in the splitting direction.
8. Release the control handle to stop the wedge movement.
9. Move the control handle opposite the splitting direction to return the wedge.

READ OPERATOR'S MANUAL

HORIZONTAL POSITION

LOCK

DANGER

AVOID SERIOUS INJURY OR DEATH

- KEEP HANDS AWAY FROM WEDGE, END PLATE, PARTLY SPLIT WOOD AND MOVING PARTS.
- NEVER LIE ON ITS SIDES AND ON ENDS.
- ONLY ONE OPERATOR PERMITTED. ADULT WHO LOADS AND HOLDS LOG MUST BE THE ONE WHO OPERATES CONTROL HANDLE. KEEP BYSTANDERS, HELPERS AND CHILDREN AT LEAST 10 FEET AWAY.
- HIGH PRESSURE FLUID CAN ESCAPE THROUGH A PIN HOLE LEAK AND CAUSE SERIOUS INJURY BY BURSTING THE SKIN AND CAUSING BLOOD POISONING. NEVER CHECK FOR LEAKS WITH YOUR HANDS.
- STABILIZE THE LOG SPLITTER ON LEVEL SURFACE. LOCK IT IN VERTICAL OR HORIZONTAL POSITION.
- NEVER OPERATE UNDER THE INFLUENCE OF ALCOHOL OR DRUGS.
- DO NOT REPAIR A HOT OR RUNNING ENGINE.

SECTION 2: ASSEMBLING YOUR LOG SPLITTER

IMPORTANT: This unit is shipped without gasoline or oil in the engine. Be certain to service engine with gasoline and oil as instructed in the separate engine manual before operating your machine.

NOTE: Reference to right or left hand side of the log splitter is observed from the operating position.

Removing Unit From Carton

- Pry the top, sides, and ends off crate.
- Set panels aside to avoid tire punctures or personal injury.
- Remove and discard plastic bag that covers unit.
- Remove wheels and loose parts if included with unit (i.e., operator's manual, etc.)



WARNING: Use extreme caution unpacking this machine. Some components are very heavy and will require additional people or mechanical handling equipment.



WARNING: Disconnect the spark plug wire and ground against the engine to prevent unintended starting.

NOTE: Do not remove the banding from around the tank until the log splitter is assembled.

- Remove the two bolts, lock washers, and hex nuts that secure the tongue assembly to the beam assembly.
- Unlock the two beam locks by pulling out on the beam locks and pivoting them down. Remove the tongue assembly. See Figure 1.
- Place the end of the tongue assembly in between the brackets on the wheel and reservoir tank assembly. Secure with hardware previously removed.

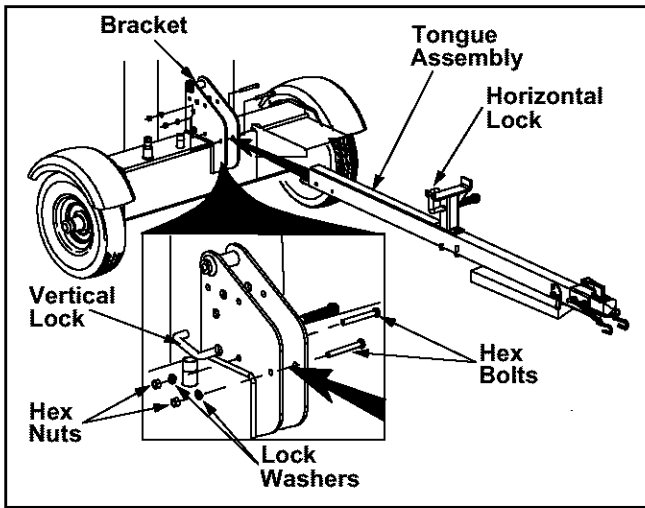

Figure 1

- Remove the spring clip and clevis pin from the jack stand. Pivot the jack stand to the operating position and secure with spring clip and clevis pin. See Figure 2.

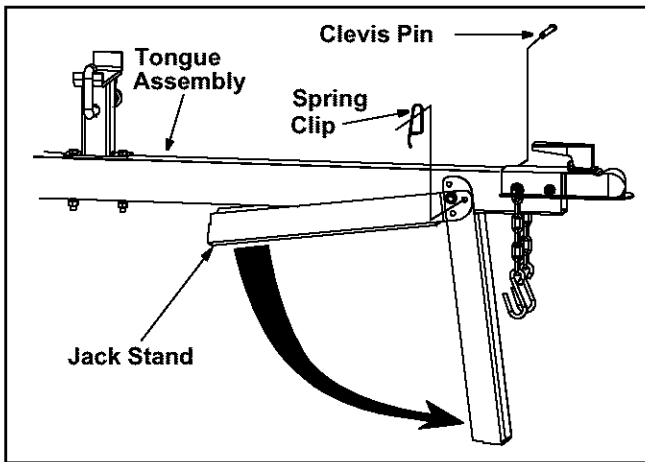

Figure 2

- Cut the two straps from around the reservoir tank assembly.
- Remove the lag screw and washer which secures the beam assembly to the bottom of the crate.
- Lower the beam assembly to its horizontal position. Make certain the beam is locked securely with the horizontal beam lock. See Figure 3.
- Pull the log splitter off the pallet.

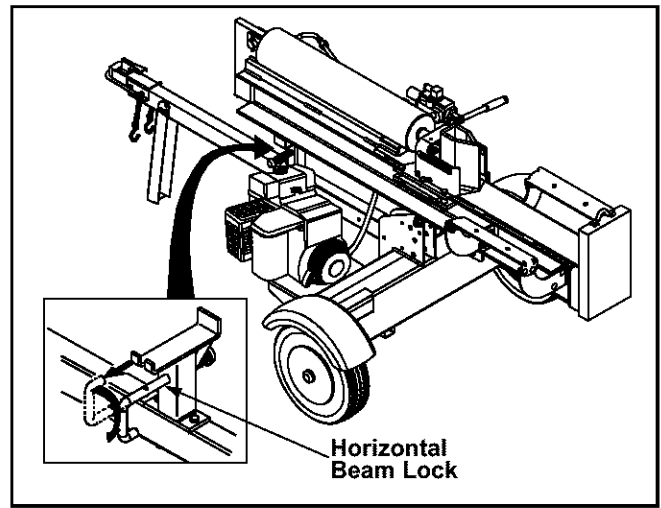

Figure 3

Preparing The Log Splitter

- Lubricate the beam area where the splitting wedge will slide with engine oil (DO NOT USE GREASE).
- Remove reservoir vent plug. See Figure 4.

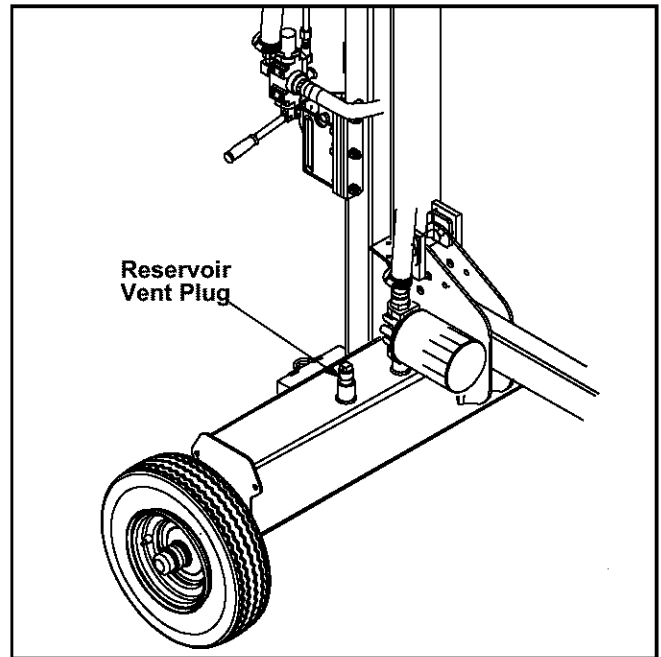

Figure 4

- Fill the reservoir tank to the within 3" to 3 1/2" from the top of fill tube with Dexron III automatic transmission fluid or 10W AW hydraulic fluid. See Figure 5.
- Check fluid level using a scale and do not overfill. Replace vent plug securely.

NOTE: The reservoir tank has a capacity of approximately 4 gallons.

- If not already, disconnect the spark plug wire and prime the pump, by pulling the recoil starter to turn the engine over approximately 10 times.

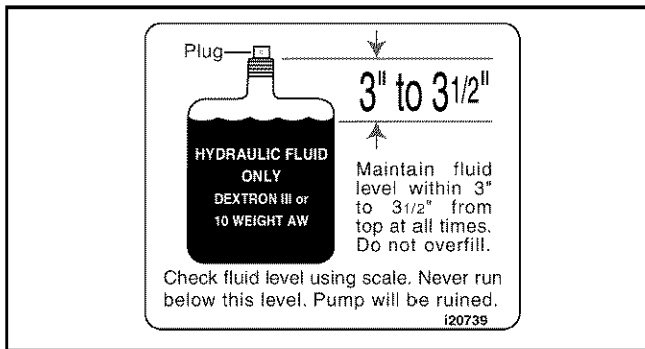

Figure 5

- Reconnect the spark plug wire.
- Start engine according to Starting the Engine in the OPERATION section.
- Use the control handle to engage the wedge to the farthest extended position and then retract the wedge.

- Refill tank to within 3" to 3 1/2" from the top of the fill tube.
- Extend and retract the wedge 12 complete cycles to remove trapped air in the system (system is "self-bleeding").
- Refill the reservoir to within 3" to 3 1/2" from the top of the fill tube. Much of the original fluid has been drawn into the cylinder and hoses. Make certain to refill the reservoir to prevent extreme damage to the hydraulic pump. Failure to refill the tank will void your warranty.

NOTE: Some fluid may overflow from the vent plug as the system builds heat and the fluid expands and seeks a balanced level.

IMPORTANT: Do not operate the log splitter without the proper amount of transmission fluid in the reservoir tank.

NOTE: Not all log splitters come equipped with a log tray.

SECTION 3: KNOW YOUR LOG SPLITTER

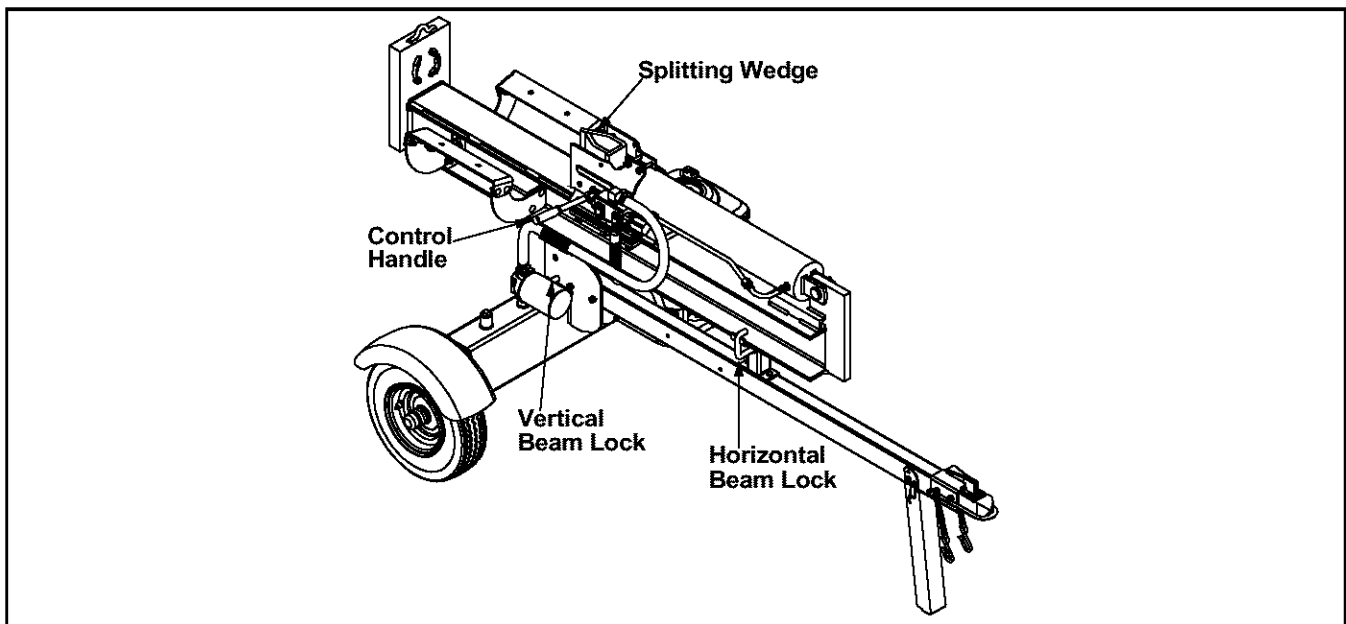

Figure 6



WARNING: Be familiar with all controls and their proper operation. Know how to stop the machine and disengage them quickly.

Control Handle

The control handle has three positions. See Figure 6.

Splitting: Push the control handle forward or down. Splitting wedge moves toward the end plate.

Neutral: Control handle will return to neutral position when handle is released. Splitting wedges stops in place.

Disengage: When pulling the control handle up or back, the splitting wedge moves toward the cylinder. The control handle will lock in the disengaged position. It will return to neutral automatically when the disengage stroke is complete.

Beam Locks

There are two beam locks one for each operating position. See Figure 6.

Vertical: The vertical beam lock is located next to the oil filter.

Horizontal: The horizontal beam lock is part of the beam support latch bracket.

Starter Handle

The starter handle is located on the engine. Pull the starter handle to start engine.

Engine Controls

See the separate engine manual for the location and function of the controls on the engine.

Stopping Engine

- Move throttle control lever to STOP or OFF position.
- Disconnect spark plug wire and ground against the engine to prevent unintended starting.

SECTION 4: OPERATING YOUR LOG SPLITTER



WARNING: Read, understand, and follow all instructions and warnings on the machine and in this manual before operating.



WARNING: Wear leather work gloves, safety shoes, and safety glasses when operating log splitter. Ensure safe footing.

Gas And Oil Fill-Up

Service the engine with gasoline and oil as instructed in the separate engine manual packed with your chipper shredder vacuum. Read instructions carefully.



WARNING: Use extreme care when handling gasoline. Gasoline is extremely flammable and the vapors are explosive. Never fuel machine indoors or while the engine is hot or running. Extinguish cigarettes, cigars, pipes, and other sources of ignition.

Starting Engine

- Attach spark plug wire to spark plug. Make certain the metal cap on the end of the spark plug is fastened securely over the metal tip on the spark plug.
- **Engines with choke lever:**
Move choke lever on engine to CHOKE position. (A warm engine may not require choking).
- **Engines with primer:**
Prime engine as instructed in separate engine manual.
- The throttle control lever is located on the engine. Move engine throttle control lever to FAST or START position.
- Grasp starter handle and pull rope out slowly until engine reaches start of compression cycle (rope will pull slightly harder at this point).
- Pull rope with a rapid, continuous, full arm stroke. Keep a firm grip on starter handle. Let rope rewind slowly.

- Repeat the previous steps until engine fires. When engine starts, move choke control (if equipped) gradually to RUN position.
- If weather is cold, run wedge up or down beam 6 to 8 times to circulate the hydraulic fluid.



WARNING: When starting a warm engine, muffle, engine, and surrounding areas become hot and can cause a burn. Do not touch.

Always:

- Use clean fluid and check fluid level regularly.
- Use Dexron III Automatic Transmission Fluid or 10W AW hydraulic fluid.
- Use a filter (clean or replace regularly)
- Use a breather cap on fluid reservoir.
- Keep end of reservoir return tube below fluid level.
- Make certain pump is mounted and aligned properly.
- Use a flexible "spider" type coupling between engine and pump drive shafts.
- Keep hoses clear and unblocked.
- Bleed air out of hoses before operating.
- Flush and clean hydraulic system before starting after any malfunction or servicing.
- Use "pipe dope" on all hydraulic fittings.
- Allow time for warm-up before splitting wood.
- Prime the pump before initial start-up by turning over the engine with spark plug disconnected.
- Split wood with the grain (lengthwise) only.

Never:

- Use when fluid is below 20° F or above 150° F.
- Use a solid engine /pump coupling.
- Operate through relief valve for more than several seconds.
- Attempt to adjust unloading or relief valve settings without pressure gauges.
- Operate with air in hydraulic system.
- Use teflon tape on hydraulic fittings.
- Attempt to cut wood across the grain.

Using The Log Splitter

- Place the log splitter on level, dry, and solid ground.
- Place the beam in either the horizontal or vertical position and lock in place with the appropriate locking rod.
- Block the front and back of both wheels.
- Place the log against the end plate and only split wood in the direction of the grain.
- When necessary to stabilize the log, place your hand only on sides of log. **NEVER place hand on the end between the log and splitting wedge.**
- Only one adult should stabilize the log and operate the control handle, so the operator has full control over stabilizing the log and movement of the splitting wedge.

Control Handle Positions

- Move control handle FORWARD or DOWN to split wood.
- Release the control handle to stop the wedge movement.
- Move control handle BACK or UP to return the wedge.

Vertical Position

- Pull the horizontal beam lock out and pivot it down to release the beam. Pivot the beam to the vertical position.
- To lock the beam in the vertical position, pull out on the vertical beam lock and pivot it to secure the beam. See Figure 7.
- Stand in front of the log splitter to operate the control handle and to stabilize the log.

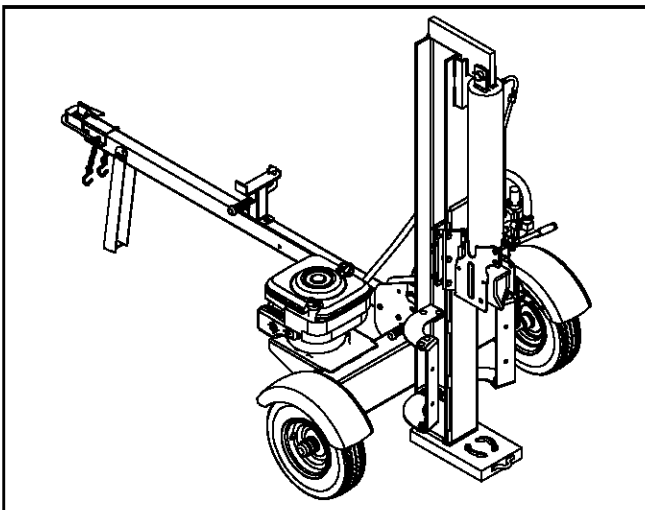

Figure 7

Horizontal Position

- Pull the vertical beam lock out and pivot it down. Pivot the beam to the horizontal position.
- To lock the beam in the horizontal position, pull out on the horizontal beam lock and pivot it to secure the beam. See Figure 8.
- Stand behind the reservoir tank to operate the control handle and to stabilize the log.

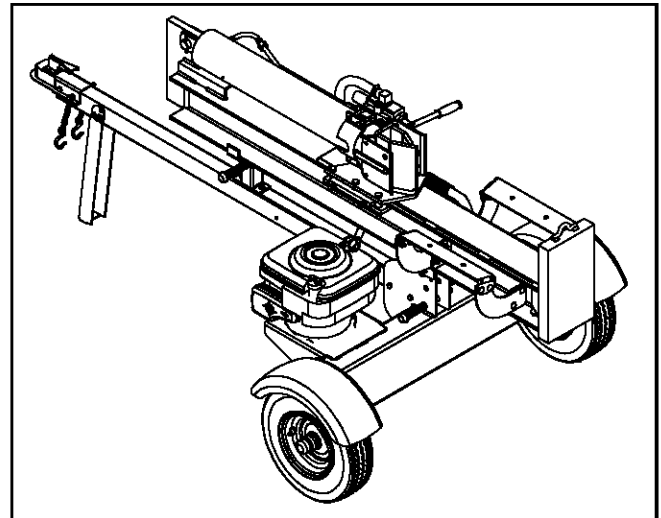

Figure 8

Transporting The Log Splitter

- Lower the beam to its horizontal position. Make certain the beam is locked securely with the horizontal beam lock.
- Remove the spring clip and clevis pin from jack stand. Support the tongue and pivot the jack stand up against the tongue. Secure with the spring clip and clevis pin previously removed.
- Attach the hitch to a towing vehicle, making certain to latch securely.
- Connect the safety chains to the towing vehicle.
- Plug in the taillights as instructed in the taillight kit manual included with your log splitter.

SECTION 5: ADJUSTING YOUR LOG SPLITTER



WARNING: Do not at any time make any adjustments without first stopping engine, disconnecting spark plug wire, and grounding it against the engine.

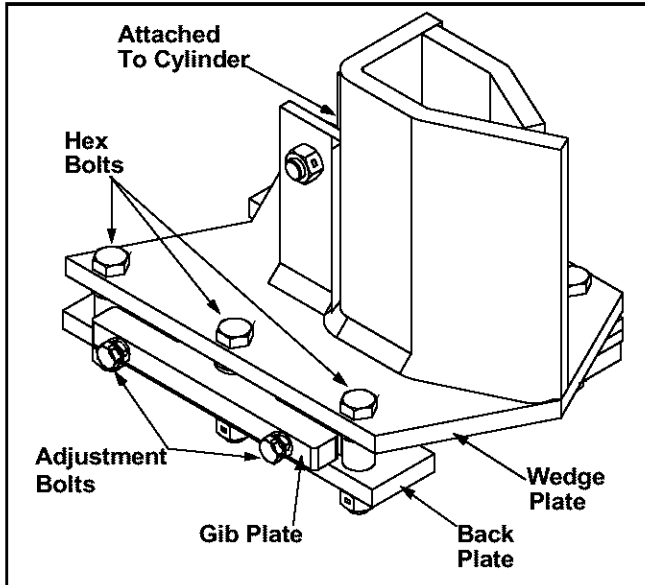

Figure 9

Wedge Plate Adjustment

As normal wear occurs, adjust the bolts on the side of the wedge plate to eliminate the excess space between the wedge plate and beam. See Figure 9.

- Loosen the jam nuts on the two adjustment bolts on the side of the gib plate. Turn the adjustment bolts in until snug and then back them off slowly until the wedge assembly will slide on the beam.
- Tighten the jam nuts securely against the gib plate to hold the adjustment bolts in this position.

Gib Plate Adjustment

Periodically remove and replace the “gibs” (spacers) between the wedge plate and the back plate. See Figure 9.

NOTE: The gibs may be rotated and/or turned over for even wear.

- Remove the center bolt on top of the wedge plate. Slide the gib plate out.
- Remove and replace the gibs.
- Reassemble the gib plate, making certain flat washers are in place under the gib plate.
- Readjust the bolts on the side of the wedge plate.

SECTION 6: MAINTAINING YOUR LOG SPLITTER



WARNING: Before cleaning, lubricating, repairing, or inspecting, disengage the control lever and stop engine. Disconnect the spark plug wire and ground it against the engine to prevent unintended starting.

Reservoir Fluid

Check the hydraulic fluid level in the log splitter reservoir tank before each use. Maintain fluid level within 3” to 3 1/2” from top at all times. Change the hydraulic fluid in the reservoir every 100 hours of operation. Disconnect the suction hose from the bottom of the reservoir tank and drain the fluid into a suitable container. Refill using only Dexron III automatic transmission fluid or 10W AW hydraulic fluid.

Be aware of the environment when disposing of used petroleum products. Please dispose of used hydraulic fluid and engine oil at approved recycling centers.



WARNING: Use extreme caution when working with kerosene, it is flammable fluid. Extinguish cigarettes, cigars, pipes, and other sources of ignition.

Hydraulic Filter

Change the hydraulic filter every 50 hours of operation. Use only a 10 micron hydraulic filter. Order part number 723-0405.

Beam And Splitting Wedge

Lubricate both sides of the beam (where it comes into contact with the splitting wedge) before each use with engine oil. The wedge plate on the log splitter is designed so the gibs on the side of the wedge plate can be removed and rotated and/or turned over for even wear. Make certain to readjust the adjustment bolts so wedge moves freely, but no excess space exists between the wedge plate and beam.

Hose Clamps

Check the hose clamps on the suction hose (attached to side of the pump) for proper tightness before each use. Check the hose clamps on the return hose at least once a season.

Engine

Refer to the separate engine manual for all engine maintenance instructions.

Flexible Pump Coupler

The flexible pump coupler is a nylon “spider” insert, located between the pump and engine shaft. Over a period of time, the coupler will harden and deteriorate.

Replacement is needed if you detect vibration or noise coming from the area between the engine and the pump. If the coupler fails completely, you will experience a loss of power.

IMPORTANT: Never hit the engine shaft in any manner, as a blow will cause permanent damage to the engine.

When replacing the flexible pump coupler, proceed as follows:

- Remove three nuts and lock washers that secure the pump to the coupling shield. Two nuts are at the bottom corners and one is in the top center.
- Remove the pump.
- Rotate the engine by pulling starter handle until engine coupling half set screw is at bottom. Loosen set screw using allen wrench and slide coupling half off of engine shaft.
- Loosen set screw on pump coupling half and remove coupling half.
- Slide new engine coupling half onto the engine shaft until the end of the shaft is flush with the inner portion of the coupling half. (There must be space between end of the engine support bracket and coupling half). Tighten set screw.
- Install pump coupling half and key on pump shaft. Rotate coupling half until set screw faces down. Do not tighten set screw.
- Install nylon “spider” onto engine coupling half.
- Align pump coupling half with nylon “spider” by rotating engine using starter handle. Slide coupling half into place while guiding three mounting bolts through holes in pump support bracket.
- Secure with nuts and washers removed earlier.

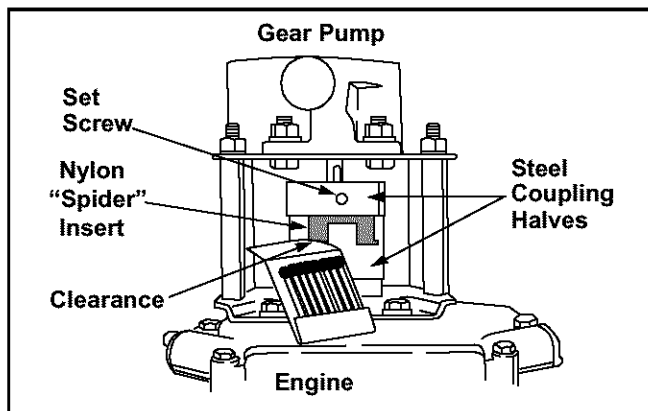

Figure 10

- Set .010" to .060" clearance between the nylon “spider” and the engine coupling half by sliding a matchbook cover between the nylon “spider” and the engine coupling half and moving pump coupling half as needed. Secure pump coupling half with set screw. See Figure 10.

NOTE: Make certain proper clearance is obtained before tightening set screw.

- Reattach spark plug wire to spark plug.

Tires

See sidewall of tire for recommended pressure.

Maximum tire pressure under any circumstances is 30 p.s.i. Equal tire pressure should be maintained on all tires.



WARNING: Excessive pressure (over 30 p.s.i.) when seating beads may cause tire/rim assembly to burst with force sufficient to cause serious injury.

Storing Your Log Splitter

- Clean the unit thoroughly.
- Wipe equipment with an oiled rag to prevent rust.
- Refer to engine manual for correct engine storage instructions.
- Store unit in a clean, dry area. Do not store next to corrosive materials such as fertilizer.



WARNING: Never store the machine or fuel container indoors where there is an open flame, spark, or pilot light such as on water heater, furnace, clothes dryer, or other gas appliance.



WARNING: Drain fuel into an approved container outdoors, away from an open flame. Allow engine to cool. Extinguish cigarettes, cigars, pipes, and other sources of ignition prior to draining fuel. Fuel left in engine for extended periods deteriorates and will cause starting problems.

SECTION 7: CONDITIONS THAT WILL VOID WARRANTY

- Failure to maintain proper fluid level in reservoir will cause permanent damage to pump by allowing air to be drawn into pump. Fluid will become foamy.
- Changing the relief valve setting or pressure adjustment of control valve without proper knowledge and instruction from the factory will void your warranty. A very minor adjustment could destroy the structural and safety limits for which the unit was designed. The system will produce more power than the structure will withstand. Higher pressure could cause the hoses to burst, cylinder to rupture, and intense fluid releases, which could result in serious personal injury.
- Disassembling the pump will void your warranty. If replacement is necessary, merely disconnect and replace. Do not attempt to adjust pump settings, as they are adjusted by the manufacturer at the factory.
- Use of incorrect hydraulic fluid will void your warranty. Use only Dexron III automatic transmission fluid or 10W AW hydraulic fluid.
- The flexible pump coupler must be inspected regularly. Allowing the coupler to deteriorate will void your warranty. Deterioration of spider insert and prolonged use after its deterioration will destroy pump bearings, engine bearings and the coupler hubs.
- Improper beam lubrication will cause premature wear and looseness. Lubricate the beam regularly. Lack of lubrication will void your warranty.
- Improper adjustment of splitting wedge will void your warranty. If wedge is too loose, cylinder beam and wedge wear will result. Allowing the wedge to loosen and be used under operating stress will cause damage which will not be covered under warranty. If wedge is too tight, severe beam damage will result which will not be covered under warranty.
- Do not overheat the hydraulic system. Excessive heat will destroy the hydraulic system with hardened O-rings and excessive friction.
- Do not attempt to start in temperatures under 20°F without pre-heating fluid in reservoir. Excessively cold fluid can not circulate and draw into pump.
- Repair any leaks in hydraulic system immediately. Unattended leaks will cause air to enter system and/or decrease fluid level in reservoir, causing damage to the hydraulic system which will not be covered by warranty.

SECTION 8: TROUBLESHOOTING

| Problem | Cause | Remedy |
|-----------------------|---|---|
| Engine fails to start | <ol style="list-style-type: none"> 1. Spark plug wire disconnected. 2. Fuel tank empty or stale fuel. 3. Throttle control lever not in correct starting position. (If Equipped) 4. Choke not in CHOKE position. (If Equipped) 5. Blocked fuel line. 6. Faulty spark plug. | <ol style="list-style-type: none"> 1. Connect wire to spark plug. 2. Fill tank with clean, fresh gasoline. 3. Move throttle lever to FAST position. 4. Move choke to CHOKE position. 5. Clean fuel line. 6. Clean, adjust gap, or replace. |
| Engine runs erratic | <ol style="list-style-type: none"> 1. Spark plug wire loose. 2. Unit running on CHOKE. (If Equipped) 3. Blocked fuel line or stale fuel. 4. Water or dirt in fuel system. 5. Dirty air cleaner. 6. Carburetor out of adjustment. | <ol style="list-style-type: none"> 1. Connect and tighten spark plug wire. 2. Move choke lever to OFF position. 3. Clean fuel line; fill tank with clean, fresh gasoline 4. Drain fuel tank. Refill with fresh fuel. 5. Clean or replace air cleaner. 6. See authorized service dealer. |
| Engine overheats | <ol style="list-style-type: none"> 1. Engine oil level low. 2. Dirty air cleaner. 3. Carburetor not adjusted properly. | <ol style="list-style-type: none"> 1. Fill crankcase with proper oil. 2. Clean or replace air cleaner. 3. See authorized service dealer. |

NOTE: For repairs beyond the minor adjustments listed above, contact your nearest authorized service dealer.

SECTION 9: HYDRAULIC TROUBLESHOOTING

| Problem | Cause | Remedy |
|---|--|--|
| Cylinder rod will not move | <ol style="list-style-type: none"> 1. Broken drive shaft. 2. Shipping plugs left in hydraulic hoses. 3. Set screws in coupling not adjusted properly. 4. Loose shaft coupling. 5. Gear sections damaged. 6. Damaged relief valve. 7. Hydraulic lines blocked. 8. Incorrect oil level. 9. Damaged directional valve. 10. Blocked directional valve. | <ol style="list-style-type: none"> 1. See authorized service dealer. 2. Disconnect hydraulic hoses, remove shipping plugs, reconnect hoses. 3. See operator's manual for correct adjustment. 4. Correct engine/pump alignment as necessary. 5. See authorized service dealer. 6. See authorized service dealer. 7. Flush and clean hydraulic system. 8. Check oil level. 9. See authorized service dealer. 10. Flush and clean hydraulic system. |
| Slow cylinder shaft speed while extending and retracting. | <ol style="list-style-type: none"> 1. Gear sections damaged. 2. Excessive pump inlet vacuum. 3. Slow engine speed. 4. Damaged relief valve. 5. Incorrect oil level. 6. Contaminated oil. 7. Directional valve leaking internally. 8. Internally damaged cylinder. | <ol style="list-style-type: none"> 1. See authorized service dealer. 2. Make certain pump inlet hoses are clear and unblocked-use short, large diameter inlet hoses. 3. See authorized service dealer. 4. See authorized service dealer. 5. Check oil level. 6. Drain oil, clean reservoir, and refill. 7. See authorized service dealer. 8. See authorized service dealer. |
| Leaking cylinder | <ol style="list-style-type: none"> 1. Broken seals. 2. Scored cylinder. | <ol style="list-style-type: none"> 1. See authorized service dealer. 2. See authorized service dealer. |
| Engine runs but wood will not split or wood splits too slowly | <ol style="list-style-type: none"> 1. Small gear section damaged. 2. Pump check valve leaking. 3. Excessive pump inlet vacuum. 4. Incorrect oil level. 5. Contaminated oil. 6. Directional valve leaking internally. 7. Overloaded cylinder. 8. Internally damaged cylinder. | <ol style="list-style-type: none"> 1. See authorized service dealer. 2. See authorized service dealer. 3. Make certain pump inlet hoses are clear and unblocked. 4. Check oil level. 5. Drain oil, clean reservoir, and refill. 6. See authorized service dealer. 7. Do not attempt to split wood against the grain. 8. See authorized service dealer. |
| Engine stalls during splitting | <ol style="list-style-type: none"> 1. Low horsepower/weak engine. 2. Overloaded cylinder. | <ol style="list-style-type: none"> 1. See authorized service dealer. 2. Do not attempt to split wood against the grain or see authorized service dealer. |
| Engine will not turn or stalls under low load conditions | <ol style="list-style-type: none"> 1. Engine/pump misalignment. 2. Frozen or seized pump. 3. Low horsepower/weak engine. 4. Hydraulic lines blocked. 5. Blocked directional valve. | <ol style="list-style-type: none"> 1. Correct alignment as necessary. 2. See authorized service dealer. 3. See authorized service dealer. 4. Flush and clean hydraulic system. 5. Flush and clean hydraulic system. |
| Leaking pump shaft seal | <ol style="list-style-type: none"> 1. Broken drive shaft. 2. Engine/pump misalignment. 3. Gear sections damaged. 4. Poorly positioned shaft seal. 5. Plugged oil breather. | <ol style="list-style-type: none"> 1. See authorized service dealer. 2. Correct alignment as necessary. 3. See authorized service dealer. 4. See authorized service dealer. 5. Make certain reservoir is properly vented. |

Model Series 500, 510, 511, 530, 550, 560, and 561

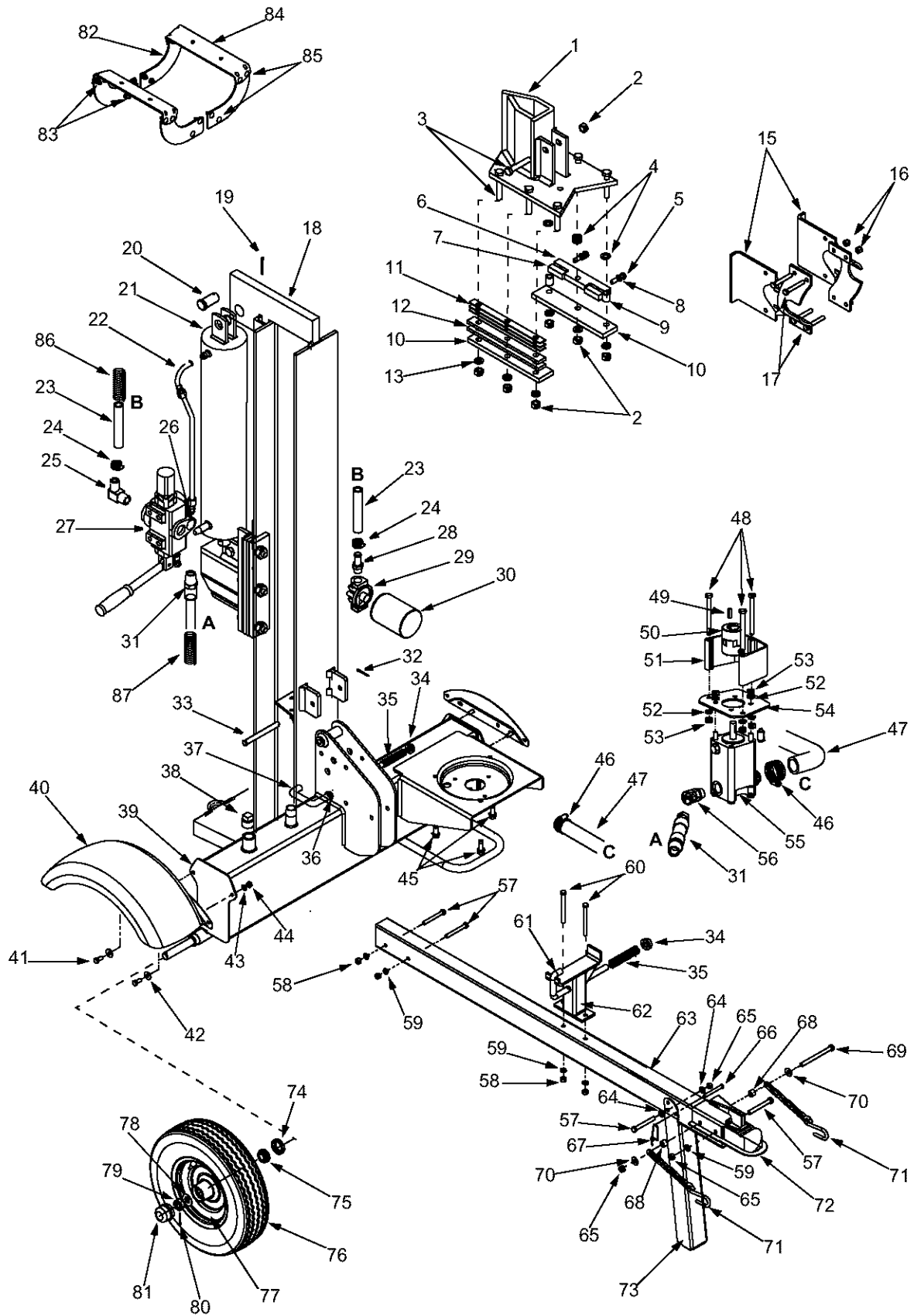

Model Series 500, 501, 510, 511, 530, 550, 560, and 561

| Ref. No. | Part No. | Part Description | Ref. No. | Part No. | Part Description |
|----------|-----------|-------------------------------|----------|-----------|-------------------------------|
| 1. | 781-0323B | Wedge Assembly | 42. | 736-0159 | Washer 5/16 † |
| 2. | 712-0239 | Lock Nut 1/2-20 | 43. | 736-0119 | Lock Washer 5/16 † |
| 3. | 710-1018 | Hex Cap Screw 1/2-20 x 2.75 | 44. | 712-0123 | Hex Nut 5/16-24 † |
| 4. | 736-0192 | Flat Washer .531 ID x .93 OD | 45. | 710-0654A | Hex Washer Screw 3/8-16 x 1.0 |
| 5. | 710-0459A | Hex Cap Screw 3/8-24 x 1.5 | 46. | 726-0174 | Hose Clamp |
| 6. | 781-0356 | Floating Gib Plate | 47. | 735-0256 | Suction Hose |
| 7. | 781-0351 | Adjustable Gib | 48. | 710-1338 | Hex Screw 5/16-24 x 3.25 |
| 8. | 712-0711 | Hex Jam Nut 3/8-24 | 49. | 714-0122 | Square Key 3/16" x .75 |
| 9. | 750-0743 | Spacer | 50. | 718-0686 | Flexible Coupling |
| | 750-0750 | Spacer † | 51. | 719-0353 | Coupling Shield |
| 10. | 781-0537 | Back Bracket | 52. | 736-0119 | Lock Washer 5/16" ID |
| 11. | 781-0352A | Adjustable Gib Shim | 53. | 712-0123 | Hex Nut 5/16-24 |
| 12. | 781-0350A | Fixed Gib | 54. | 781-0097 | Rear Coupling Support Bracket |
| 13. | 736-0921 | Lock Washer 1/2 | 55. | 718-0683 | Gear Pump (11gpm) |
| 14. | 712-0239 | Lock Nut 1/2-20 | 56. | 737-0329 | 45 Degree Elbow |
| 15. | 781-0168A | Stripper Side | 57. | 710-0521 | Hex Bolt 3/8-16 x 3" |
| 16. | 712-0130 | Lock Nut 3/8-16 | 58. | 712-0798 | Hex Nut 3/8-16 |
| 17. | 710-0859 | Hex Cap Screw 3/8-16 x 2.5 | 59. | 736-0169 | L-Washer 3/8" |
| 18. | 681-0102 | Beam Assembly | 60. | 710-0411 | Hex Bolt 3/8-16 x 4" |
| | 681-0093 | Beam Assembly (w/o Tray) | 62. | 681-0110 | Support Beam Assembly |
| | 681-0127 | Beam Assembly † | 63. | 781-0680A | Tube |
| | 681-0126 | Beam Assembly (w/o Tray) | 64. | 736-0185 | Flat Washer 3/8 |
| 19. | 714-0211 | Cotter Pin | 65. | 712-0375 | Hex Lock Nut 3/8-16 |
| 20. | 711-1135 | Clevis Pin | 66. | 711-0813 | Clevis Pin 5/16 x 2.5" |
| 21. | 718-0306 | Hydraulic Cylinder | 67. | 732-0194 | Spring Pin |
| 22. | 727-0471 | Hydraulic Tube | 68. | 750-0497 | Spacer 3/8" ID x .625" OD |
| 23. | 727-0443 | Return Hose 3/4" ID x 44" Lg. | 69. | 710-0944 | Hex Bolt 3/8-16 x 4" |
| 24. | 726-0132 | Hose Clamp 5/8" | 70. | 736-0262 | Flat Washer 3/8" ID x .87" OD |
| 25. | 737-0153 | Return Elbow | 71. | 713-0433 | Chain |
| 26. | 737-0192 | 90 Degree Solid Adapter | 72. | 727-0311 | Hitch Coupler |
| 27. | 718-0481 | Control Valve | 73. | 781-0162 | Jack Stand |
| 28. | 727-0235 | 3/4" Hose Adapter | 74. | 721-0168 | Bearing Seal |
| 29. | 737-0316 | Filter Housing | 75. | 741-0987 | Bearing Cone |
| 30. | 723-0405 | Oil Filter | 76. | 634-0186 | Wheel Assembly |
| 31. | 727-0502 | High Pressure Hydraulic Hose | 77. | 634-0180 | Rim Assembly |
| 32. | 714-0470 | Cotter Pin | 78. | 736-0351 | Flat Washer .76" ID x 1.5" OD |
| 33. | 738-0805 | Hinge Pin 1/2 x 4.8" | 79. | 712-0359 | Slotted Nut 3/4-16 |
| 34. | 726-0214 | Push Cap | 80. | 714-0162 | Cotter Pin 5/32" x 1-1/4" |
| 35. | 732-0583 | Compression Spring 4" | 81. | 734-0873 | Hub Cap |
| 36. | 736-0116 | Flat Washer .635 ID x .93 OD | 82. | 781-0686 | Log Tray Bracket |
| 37. | 781-0690 | Locking Rod | 83. | 712-0431 | Flanged Lock Nut 3/8-16 |
| 38. | 737-0236 | Pipe Plug | 84. | 781-0682 | Log Tray |
| 39. | 681-0176 | Frame Assembly 4.0 Gal | 85. | 710-3097 | Carriage Bolt 3/8-16 x 1.0 |
| 40. | 681-0138 | Fender Assembly † | 86. | 781-0526 | Hose Guard † |
| 41. | 710-0157 | Hex Cap Screw 5/16-24 x .75 † | 87. | 781-0538 | Hose Guard † |

† Models 530, 550, 560, and 561

Note: Not all log splitters come equipped with a log tray.

MANUFACTURER'S LIMITED WARRANTY FOR:



The limited warranty set forth below is given by MTD PRODUCTS INC ("MTD") with respect to new merchandise purchased and used in the United States, its possessions and territories.

MTD warrants this product against defects in material and workmanship for a period of two (2) years commencing on the date of original purchase and will, at its option, repair or replace, free of charge, any part found to be defective in material or workmanship. This limited warranty shall only apply if this product has been operated and maintained in accordance with the Operator's Manual furnished with the product, and has not been subject to misuse, abuse, commercial use, neglect, accident, improper maintenance, alteration, vandalism, theft, fire, water or damage because of other peril or natural disaster. Damage resulting from the installation or use of any accessory or attachment not approved by MTD Products Inc. for use with the product(s) covered by this manual will void your warranty as to any resulting damages.

Normal wear parts or components thereof are subject to separate terms as follows: All normal wear part or component failures will be covered on the product for a period of 90 days regardless of cause. After 90 days, but within the two year period, normal wear part failures will be covered ONLY IF caused by defects in material or workmanship of OTHER component parts. Normal wear parts and components include, but are not limited to, belts, blades, blade adapters, grass bags, rider deck wheels, seats, snow thrower skid shoes, shave plates and tires. Batteries are covered by a 90-day limited replacement warranty.

HOW TO OBTAIN SERVICE: Warranty service is available, WITH PROOF OF PURCHASE THROUGH YOUR LOCAL AUTHORIZED SERVICE DEALER. To locate the dealer in your area, please check for a listing in the Yellow Pages or contact the Customer Service Department of MTD PRODUCTS INC by calling 1-800-800-7310 or writing to P.O. Box 368022, Cleveland, Ohio 44136-9722.

This limited warranty does not provide coverage in the following cases:

- a. The engine or component parts thereof. These items carry a separate manufacturer's warranty. Please refer to the applicable manufacturer's warranty on these items.
- b. Log splitter pumps, valves and cylinders have a separate one year warranty.

- c. Routine maintenance items such as lubricants, filters, blade sharpening and tune-ups, or adjustments such as brake adjustments, clutch adjustments or deck adjustments; and normal deterioration of the exterior finish due to use or exposure.
- d. MTD does not extend any warranty for products sold or exported outside of the United States of America, its possessions and territories, except those sold through MAD's authorized channels of export distribution.

No implied warranty, including any implied warranty of merchantability or fitness for a particular purpose, applies after the applicable period of express written warranty above as to the parts as identified. No other express warranty or guaranty, whether written or oral, except as mentioned above, given by any person or entity, including a dealer or retailer, with respect to any product shall bind MTD. During the period of the Warranty, the exclusive remedy is repair or replacement of the product as set forth above. (Some states do not allow limitations on how long an implied warranty lasts, so the above limitation may not apply to you.)

The provisions as set forth in this Warranty provide the sole and exclusive remedy arising from the sales. MTD shall not be liable for incidental or consequential loss or damages including, without limitation, expenses incurred for substitute or replacement lawn care services, for transportation or for related expenses, or for rental expenses to temporarily replace a warranted product. (Some states do not allow the exclusion or limitation of incidental or consequential damages, so the above exclusion or limitation may not apply to you.)

In no event shall recovery of any kind be greater than the amount of the purchase price of the product sold. Alteration of the safety features of the product shall void this Warranty. You assume the risk and liability for loss, damage, or injury to you and your property and/or to others and their property arising out of the use or misuse or inability to use the product.

This limited warranty shall not extend to anyone other than the original purchaser, original lessee or the person for whom it was purchased as a gift.

How State Law Relates to this Warranty: This limited warranty gives you specific legal rights, and you may also have other rights which vary from state to state.