

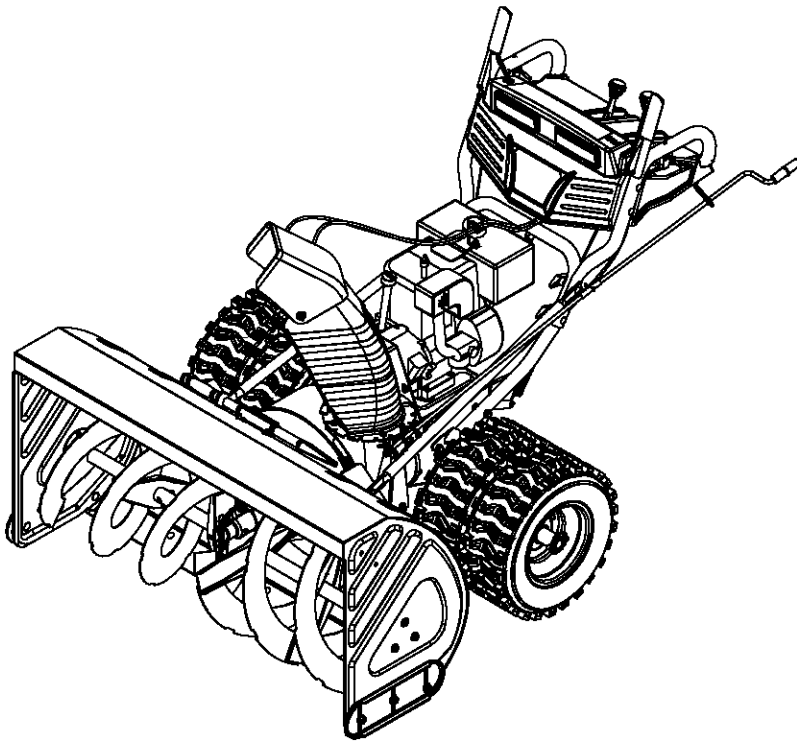

Operator's Manual

Snow Thrower Model
13045—Polar Blast



IMPORTANT: READ SAFETY RULES AND INSTRUCTIONS CAREFULLY

WARNING: This unit is equipped with an internal combustion engine and should not be used on or near any unimproved forest-covered, brush-covered or grass-covered land unless the engine's exhaust system is equipped with a spark arrester meeting applicable local or state laws (if any). If a spark arrester is used, it should be maintained in effective working order by the operator. In the State of California the above is required by law (Section 4442 of the California Public Resources Code). Other states may have similar laws. Federal laws apply on federal lands. A spark arrester for the muffler is available through your nearest engine authorized service dealer or contact the service department, P.O. Box 361131 Cleveland, Ohio 44136-0019.

TROY-BILT LLC, P.O. BOX 361131 CLEVELAND, OHIO 44136-0019

TABLE OF CONTENTS

Content	Page
Important Safe Operation Practices	3
Loose Parts & Hardware Pack.....	5
Assembling Your Snow Thrower	7
Know Your Snow Thrower.....	10
Operating Your Snow Thrower	11
Making Adjustments.....	13
Maintaining Your Snow Thrower	14
Service	15
Off-Season Storage.....	17
Troubleshooting	18
Parts List	19

FINDING MODEL NUMBER

This Operator's Manual is an important part of your new snow thrower. It will help you assemble, prepare and maintain the unit for best performance. Please read and understand what it says.



Before you start assembling your new equipment, please locate the model plate on the equipment and copy the information from it in the space provided below. The information on the model plate is very important if you need help from our Customer Support Department or an authorized dealer.

You can locate the model number by standing behind the unit in the operating position and looking down at the rear frame below the engine. A sample model plate is explained below. For future reference, please copy the model number and the serial number of the equipment in the space below.

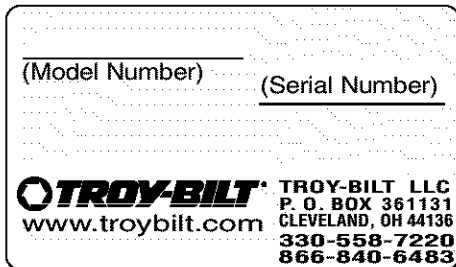

Copy the model number here: _____

Copy the serial number here: _____

ENGINE INFORMATION

The engine manufacturer is responsible for all engine-related issues with regard to performance, power-rating, specifications, warranty and service. Please refer to the engine manufacturer's Owner's/Operator's Manual packed separately with your unit for more information.

CALLING CUSTOMER SUPPORT

Please do NOT return the unit to the retailer from which it was purchased, without first contacting Customer Support.

Should you have difficulty assembling this product or have any questions regarding the controls, operation or maintenance of this unit, please call the Customer Support Department.



Call **1-(330) 558-7220** or **1-(866) 840-6483** to reach a Customer Support representative. Please have your unit's model number and serial number ready when you call. See previous section to locate this information. You will be asked to enter the serial number in order to process your call.

For more details about your unit, visit our website at www.troybilt.com

SECTION 1: IMPORTANT SAFE OPERATION PRACTICES



This symbol points out important safety instructions, which if not followed, could endanger the personal safety and/or property of yourself and others. Read and follow all instructions in this manual before attempting to operate this machine. Failure to comply with these instructions may result in personal injury. When you see this symbol—**heed its warning.**



WARNING: Engine Exhaust, some of its constituents, and certain vehicle components contain or emit chemicals known to the State of California to cause cancer, birth defects or other reproductive harm.



DANGER: This machine was built to be operated according to the rules for safe operation in this manual. As with any type of power equipment, carelessness or error on the part of the operator can result in serious injury. This machine is capable of amputating hands and feet and throwing objects. Failure to observe the following safety instructions could result in serious injury or death.

TRAINING

1. Read, understand, and follow all instructions on the machine and in the manual(s) before attempting to assemble and operate. Keep this manual in a safe place for future and regular reference and for ordering replacement parts.
2. Be familiar with all controls and their proper operation. Know how to stop the machine and disengage them quickly.
3. Never allow children under 14 years old to operate this machine. Children 14 years old and over should read and understand the operation instructions and safety rules in this manual and should be trained and supervised by a parent.
4. Never allow adults to operate this machine without proper instruction.
5. Thrown objects can cause serious personal injury. Plan your snow-throwing pattern to avoid discharge of material toward roads, bystanders and the like.
6. Keep bystanders, helpers, pets and children at least 75 feet from the machine while it is in operation. Stop machine if anyone enters the area.
7. Exercise caution to avoid slipping or falling, especially when operating in reverse.
6. Disengage all clutch levers before starting the engine.
7. Never attempt to make any adjustments while engine is running, except where specifically recommended in the operator's manual.
8. Let engine and machine adjust to outdoor temperature before starting to clear snow.
9. To avoid personal injury or property damage use extreme care in handling gasoline. Gasoline is extremely flammable and the vapors are explosive. Serious personal injury can occur when gasoline is spilled on yourself or your clothes, which can ignite. Wash your skin and change clothes immediately.
 - a. Use only an approved gasoline container.
 - b. Extinguish all cigarettes, cigars, pipes and other sources of ignition.
 - c. Never fuel machine indoors.
 - d. Never remove gas cap or add fuel while the engine is hot or running.
 - e. Allow engine to cool at least two minutes before refueling.
 - f. Never over fill fuel tank. Fill tank to no more than 1/2 inch below bottom of filler neck to provide space for fuel expansion.
 - g. Replace gasoline cap and tighten securely.
 - h. If gasoline is spilled, wipe it off the engine and equipment. Move machine to another area. Wait 5 minutes before starting the engine.
 - i. Never store the machine or fuel container inside where there is an open flame, spark or pilot light (e.g. furnace, water heater, space heater, clothes dryer etc.).
 - j. Allow machine to cool at least 5 minutes before storing.

PREPARATION

1. Thoroughly inspect the area where the equipment is to be used. Remove all doormats, newspapers, sleds, boards, wires and other foreign objects, which could be tripped over or thrown by the auger/impeller.
2. Always wear safety glasses or eye shields during operation and while performing an adjustment or repair to protect your eyes. Thrown objects which ricochet can cause serious injury to the eyes.
3. Do not operate without wearing adequate winter outer garments. Do not wear jewelry, long scarves or other loose clothing, which could become entangled in moving parts. Wear footwear which will improve footing on slippery surfaces.
4. Use a grounded three-wire extension cord and receptacle for all units with electric start engines.
5. Adjust collector housing height to clear gravel or crushed rock surfaces.

OPERATION

1. Do not put hands or feet near rotating parts, in the auger/impeller housing or discharge chute. Contact with the rotating parts can amputate hands and feet.
2. The auger/impeller clutch lever is a safety device. Never bypass its operation. Doing so makes the machine unsafe and may cause personal injury.
3. The clutch levers must operate easily in both directions and automatically return to the disengaged position when released.

4. Never operate with a missing or damaged discharge chute. Keep all safety devices in place and working.
5. Never run an engine indoors or in a poorly ventilated area. Engine exhaust contains carbon monoxide, an odorless and deadly gas.
6. Do not operate machine while under the influence of alcohol or drugs.
7. Muffler and engine become hot and can cause a burn. Do not touch.
8. Exercise extreme caution when operating on or crossing gravel surfaces. Stay alert for hidden hazards or traffic.
9. Exercise caution when changing direction and while operating on slopes.
10. Plan your snow-throwing pattern to avoid discharge towards windows, walls, cars etc. Thus, avoiding possible property damage or personal injury caused by a ricochet.
11. Never direct discharge at children, bystanders and pets or allow anyone in front of the machine.
12. Do not overload machine capacity by attempting to clear snow at too fast of a rate.
13. Never operate this machine without good visibility or light. Always be sure of your footing and keep a firm hold on the handles. Walk, never run.
14. Disengage power to the auger/impeller when transporting or not in use.
15. Never operate machine at high transport speeds on slippery surfaces. Look down and behind and use care when in reverse.
16. If the machine should start to vibrate abnormally, stop the engine, disconnect the spark plug wire and ground it against the engine. Inspect thoroughly for damage. Repair any damage before starting and operating.
17. Disengage all clutch levers and stop engine before you leave the operating position (behind the handles). Wait until the auger/impeller comes to a complete stop before unclogging the discharge chute, making any adjustments, or inspections.
18. Never put your hand in the discharge or collector openings. Always use the clean-out tool provided to unclog the discharge opening. Do not unclog discharge chute while engine is running. Shut off engine and remain behind handles until all moving parts have stopped before unclogging.
19. Use only attachments and accessories approved by the manufacturer (e.g. wheel weights, tire chains, cabs etc.).
20. If situations occur which are not covered in this manual, use care and good judgment.

Contact your dealer or telephone **1 (866) 840-6483** for assistance and the name of your nearest servicing dealer.

MAINTENANCE AND STORAGE

1. Never tamper with safety devices. Check their proper operation regularly. Refer to the maintenance and adjustment sections of this manual.
2. Before cleaning, repairing or inspecting machine disengage all clutch levers and stop engine. Wait until the auger/impeller come to a complete stop. Disconnect the spark plug wire and ground against the engine to prevent unintended starting.
3. Check bolts and screws for proper tightness at frequent intervals to keep the machine in safe working condition. Also, visually inspect machine for any damage.
4. Do not change the engine governor setting or over-speed the engine. The governor controls the maximum safe operating speed of the engine.
5. Snow thrower shave plates and skid shoes are subject to wear and damage. For your safety protection, frequently check all components and replace with original equipment manufacturer's (OEM) parts only. "Use of parts which do not meet the original equipment specifications may lead to improper performance and compromise safety!"
6. Check clutch controls periodically to verify they engage and disengage properly and adjust, if necessary. Refer to the adjustment section in this operator's manual for instructions.
7. Maintain or replace safety and instruction labels, as necessary.
8. Observe proper disposal laws and regulations for gas, oil, etc. to protect the environment.
9. Prior to storing, run machine a few minutes to clear snow from machine and prevent freeze up of auger/impeller.
10. Never store the machine or fuel container inside where there is an open flame, spark or pilot light such as a water heater, furnace, clothes dryer etc.
11. Always refer to the operator's manual for proper instructions on off-season storage.

WARNING — YOUR RESPONSIBILITY:

Restrict the use of this power machine to persons who read, understand and follow the warnings and instructions in this manual and on the machine. The safety labels are shown below for your reference.

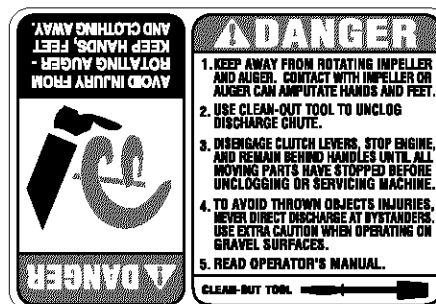

SECTION 2: ASSEMBLING YOUR SNOW THROWER

NOTE: All references to right or left side of the snow thrower are determined from behind the unit in the operating position. The "operator's position" is defined as standing directly behind the snow thrower, facing the handle panel.

Loose Parts

- The augers are secured to the auger shaft with two shear bolts and hex lock nuts. If you hit a foreign object or ice jam, the snow thrower is designed so that the bolts may shear. Two replacement shear bolts and nuts are provided for your convenience. Store in a safe place until needed. See Figure 1.

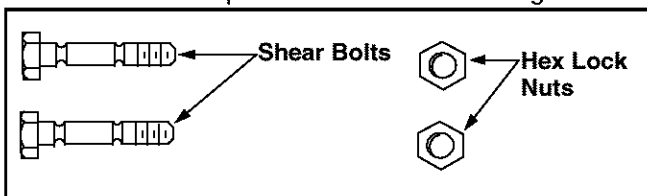

Figure 1

IMPORTANT: NEVER replace the auger shear bolts with standard hex bolts. Any damage to the auger gearbox or other components from standard hex bolts will not be covered by your snow thrower's warranty.

Assembling Handle



WARNING: Disconnect the spark plug wire and ground it against the engine to prevent unintended starting.

IMPORTANT: Make any adjustments, as instructed on Page 10, before operating your snow thrower. Failure to follow these instructions may cause damage to the snow thrower.

- Remove the **lower** plastic wing nut, cupped washer and carriage bolt from each side of the lower handle. See Figure 2.

NOTE: Before proceeding, look at the lower rear of the snow thrower frame to be sure the spring (found at the end of each cable) is attached to its actuator bracket. See Figure 3.

- Pivot the upper handle assembly forward until it locks over the lower handle. See Figure 2.
- Secure the upper handle and lower handle with the two plastic wing nuts, bell washers and carriage bolts previously removed from the lower hole.
- Firmly tighten all four wing nuts to secure the upper handle to the lower handles.

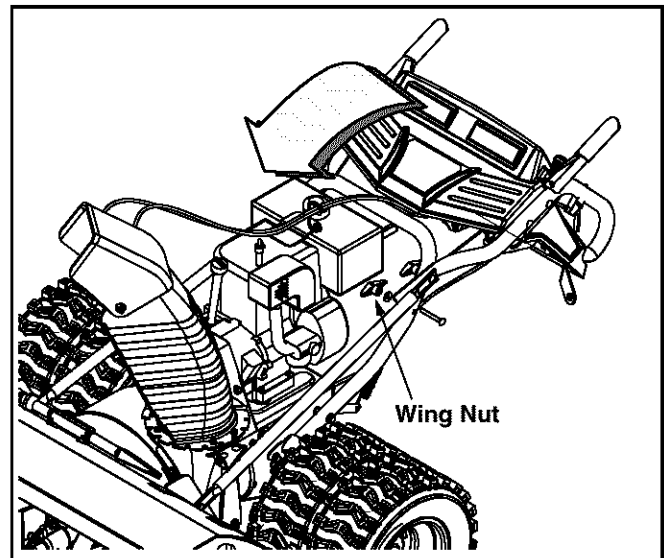

Figure 2

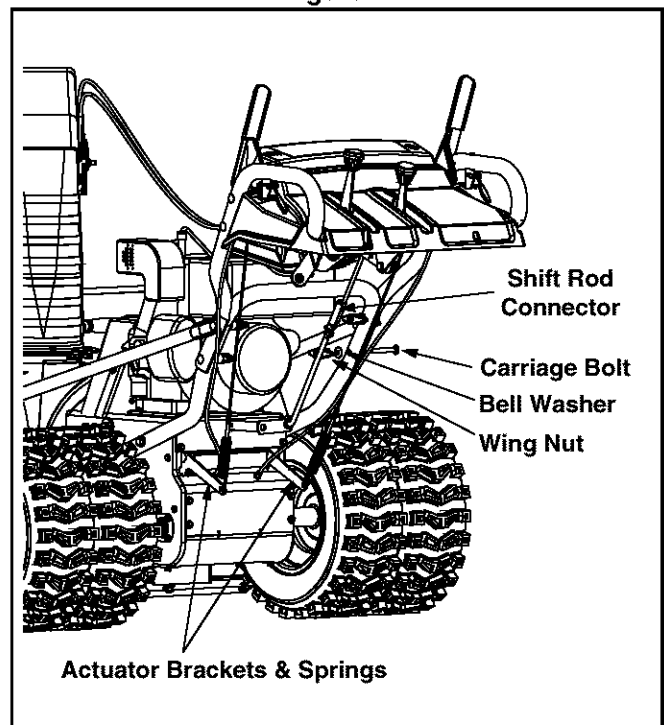

Figure 3

- Slide the shift rod connector down over the end of the lower shift rod. Tap the connector until it **locks** over the lower shift rod. See Figure 3.

NOTE: If the connector is not properly assembled, the shift rod will pivot and you will not be able to change speeds or change directions.

Attaching Chute Directional Control

- Remove the hairpin clip from the upper rod and slide the upper rod through the bracket and into the lower rod. See Figure 4.
- Align the two holes on both chute cranks and insert the hairpin clip removed earlier, through these holes. See Figure 4.

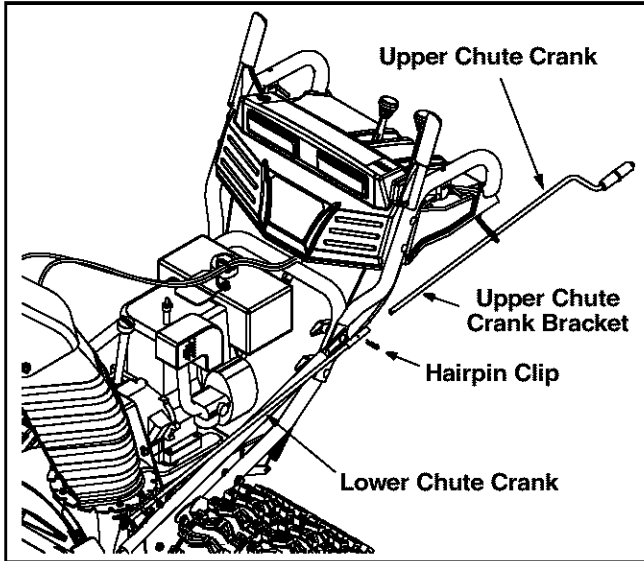

Figure 4

Routing Chute Tilt Cables

- If not already routed, slip the cables that run from beneath the handle panel to the discharge chute through the cable guide located on top of the engine housing. See Figure 5.

Connecting Alternator Lead

- Unwrap the headlight wire which is attached to the headlights, beneath the handle panel. Wind the wire around the lower right handle until excess slack is removed. See Figure 6.

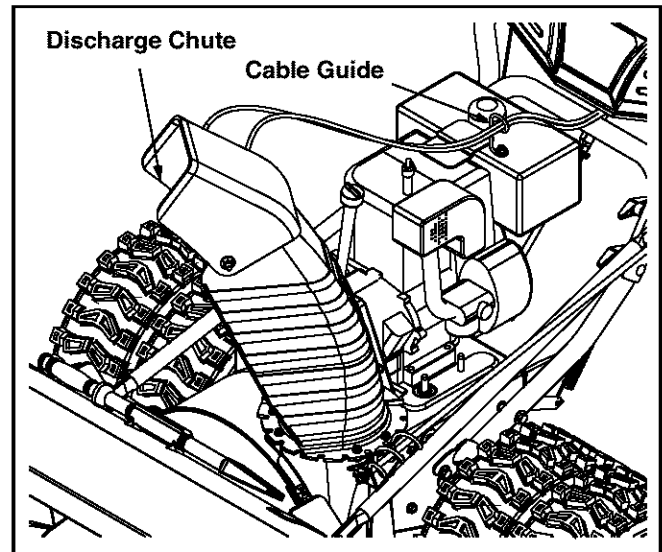

Figure 5

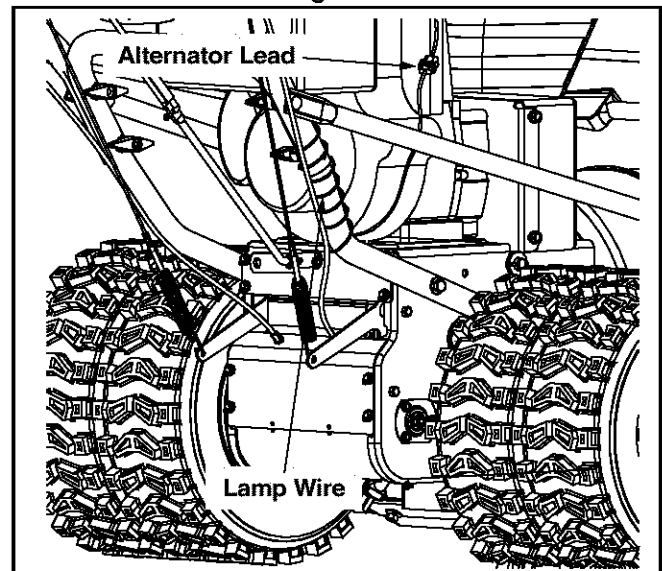

Figure 6

- Plug the wire from the headlight into the alternator lead located on the right side of the engine, beneath the fuel tank. See Figure 6.

SECTION 3: KNOW YOUR SNOW THROWER



WARNING: Read, understand, and follow all instructions and warnings on the machine and in this manual before operating.

Chute Tilt Control

The distance snow is thrown can be changed by adjusting the angle of the chute assembly. Move the chute tilt control forward to decrease the distance, toward the rear to increase. See Figure 7.

Throttle Control

The throttle control is located on the engine. It regulates the speed of the engine. See Figure 7.

Discharge Chute

The angle of the discharge chute controls the distance that the snow is thrown. Tilt the discharge chute up for greater distance; tilt down for less distance.

Skid Shoes

The space between the shave plate and the ground can be adjusted by positioning the skid shoes. Refer to **Skid Shoe Adjustment** on page 12.

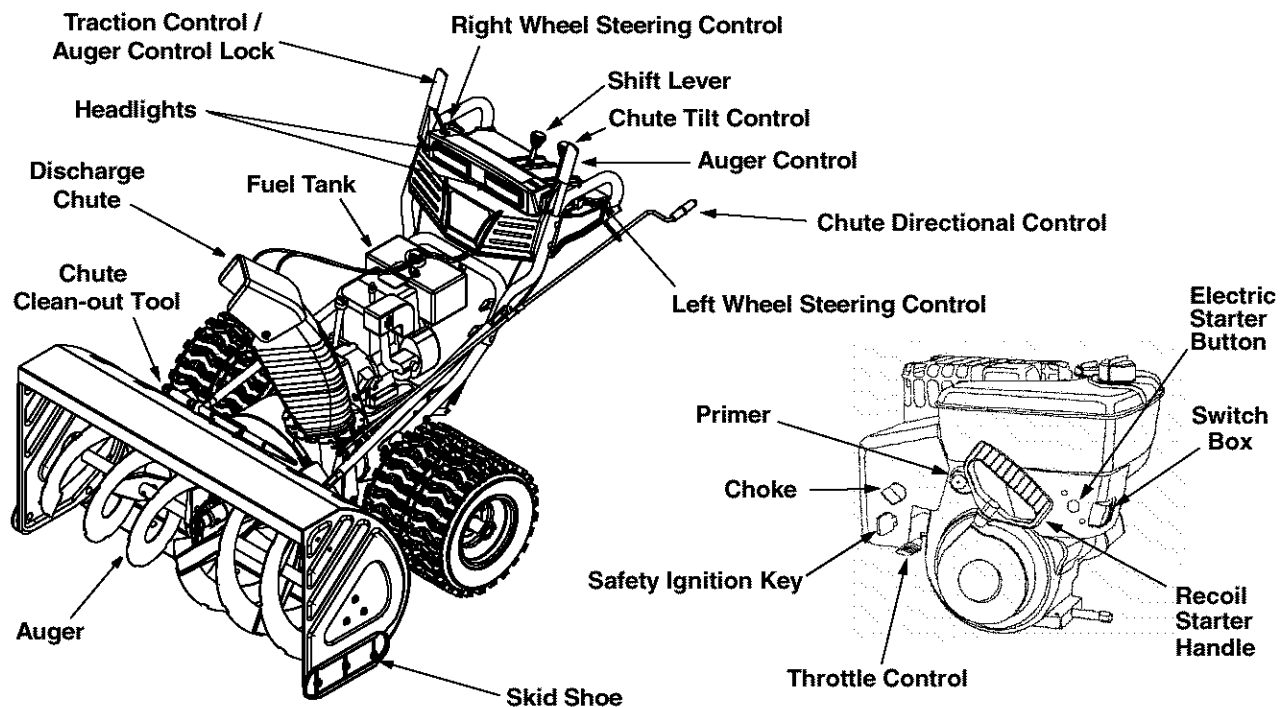

Figure 7

Safety Ignition Key

The ignition key must be inserted in the switch in order for the engine to start. Remove the ignition key when the snow thrower is not in use.

NOTE: Do NOT “turn” the ignition key in an attempt to start the engine.

Shift Lever

The shift lever is located in the center of the handle panel and is used to determine ground speed and direction of travel. It can be moved into any of eight positions. See Figure 7.

IMPORTANT: Always release traction the control before changing speeds.

Forward

Your snow thrower has six forward (F) speeds. Position number one (1) is the slowest and position number six (6) is the fastest.

Reverse

Your snow thrower has two reverse (R) speeds. R1 is the slower, while R2 is the faster of the two.

Traction Control / Auger Control Lock

The traction control is located on the right handle. Squeeze the traction control to engage the wheel drive. Release to stop. See Figure 7.

This same lever also locks the auger control lock, so you can operate the chute crank without interrupting the snow throwing process. If the auger control is engaged simultaneously with the traction control, the operator

can release the auger control (on the left handle) and the augers will remain engaged. Release the traction control to stop both the augers and wheel drive (the auger control must also be released).

IMPORTANT: ALWAYS release the traction control before moving the shift lever. Failure to do so will result in premature wear to the drive system’s friction wheel.

Auger Control

The auger control is located on the left handle. Squeeze the auger control to engage the augers. Release to stop the snow throwing action. The traction control must also be released in order to stop the auger.

IMPORTANT: Refer to **Auger Control Test** on page 9 prior to operating your snow thrower. Read and follow all instructions carefully and perform all adjustments to verify your snow thrower is operating safely and properly.

Chute Directional Control

The chute directional control is located on left hand side of the snow thrower. To change the direction which snow is thrown, rotate chute directional control as follows:

- Clockwise to discharge to the left.
- Counterclockwise to discharge to the right.

Headlights

When properly connected, both headlights illuminate whenever the engine is running.

Chute Clean-out Tool



WARNING: Never use your hand to clear a clogged discharge chute. Shut off engine and remain behind handles until all moving parts have stopped before unclogging.

This item is fastened with a cable tie to the rear of the Auger Housing at the factory. Cut the cable tie before operating the snow thrower.

The chute clean-out tool (see Figure 7) is designed to clear a clogged discharge chute. Refer to page 10 for detailed instructions on how to properly use the chute clean-out tool.

Wheel Steering Controls

The left and right wheel steering controls are located on the underside of the handles and are used to assist in steering the snow thrower.

- Squeeze the right wheel steering control when turning right; squeeze the left control when turning left.
- Operate the snow thrower in open areas until becoming familiar with these controls.

SECTION 4: OPERATING YOUR SNOW THROWER

Before Starting



WARNING: Read, understand, and follow all instructions and warnings on the machine and in this manual before operating.

Gas And Oil Fill-up

Service the engine with gasoline and oil as instructed in the separate engine manual packed with your snow thrower. **Read instructions carefully.**



WARNING: Use extreme care when handling gasoline. Gasoline is extremely flammable and the vapors are explosive. Never fuel machine indoors or while the engine is hot or running. Extinguish cigarettes, cigars, pipes and other sources of ignition.

- A plastic cap is provided inside the fuel fill opening on the fuel tank. Remove and discard this cap before filling up the tank. Use the separate fuel tank cap to close after fill-up.

To Start Engine

NOTE: If unit shows any sign of motion (drive or augers) with the clutch grips disengaged, shut engine off immediately. Readjust as instructed on page 9—Auger Control Test) and page 10—Traction Control and Shift Lever.

- Attach spark plug wire to spark plug. Make certain the metal loop on end of the spark plug wire (inside the boot) is fastened securely over the metal tip on the spark plug.

- Make certain the auger and drive clutch levers are in the disengaged (released) position.
- Move throttle control up to FAST position. Insert ignition key into slot. See NOTE:. Be certain it snaps into place. **Do not turn key.**

NOTE: Engine will not start unless ignition key is inserted into ignition slot in carburetor cover.

Electric Starter

- Determine that your house wiring is a three-wire grounded system. Ask a licensed electrician if you are not certain.



WARNING: The electric starter is equipped with a grounded three-wire power cord and plug and is designed to operate on 120 volt AC household current. It must be used with a properly grounded three-prong receptacle at all times to avoid the possibility of electric shock. Follow all instructions carefully prior to operating the electric starter.

- If your house wiring system is not a three-wire grounded system, do not use this electric starter under any conditions.
- If your home electrical system is grounded, but a three-hole receptacle is not available, one should be installed by a licensed electrician before using the electric starter.
- If you have a grounded three-prong receptacle, proceed as follows:
- Rotate choke knob to OFF position and do NOT prime engine.
- Connect power cord to switch box on engine. Plug the other end of power cord into a three-hole, grounded 120 volt AC receptacle.
- Push the electric starter button (Refer to NOTE:) to crank engine. As you crank the engine, move choke knob to FULL choke position.

- When engine starts, release starter button, and move choke gradually to OFF. If engine falters, move choke immediately to FULL and then gradually to OFF.
- When disconnecting the power cord, always unplug from the three-prong receptacle first and then from the snow thrower.

Recoil Starter

- Rotate choke knob to FULL choke position (cold engine start). If engine is warm, place choke in OFF position instead of FULL.
- Push primer button two or three times. If engine is warm, push primer button once only.

NOTE: Always cover vent hole in primer button when pushing. Additional priming may be necessary for first start if temperature is below 15°F.

- Grasp starter handle and pull rope out slowly, until it pulls slightly harder. Let rope rewind slowly.
- Pull starter handle rapidly. Do not allow handle to snap back. Allow it to rewind slowly while keeping a firm hold on the starter handle.
- Repeat the previous steps until engine starts.

To Stop Engine

- Run engine for a few minutes before stopping to help dry off any moisture on the engine.
- To help prevent possible freeze-up of starter, proceed as follows.

Electric Starter:

- Connect power cord to switch box on engine, then to 120 volt AC receptacle. With the engine running, push starter button and spin the starter for several seconds. The unusual sound made by spinning the starter will not harm engine or starter. Disconnect the power cord from receptacle first, and then from switch box.

Recoil Starter

- With engine running, pull starter rope with a rapid, continuous full arm stroke three or four times. Pulling the starter rope will produce a loud clattering sound, which is not harmful to the engine or starter.
- Move throttle control to “stop” or “off” position.
- Remove ignition key. Do not turn key. Disconnect the spark plug wire from the spark plug to prevent accidental starting while equipment is unattended.

Wipe all snow and moisture from the carburetor cover in the area of the control levers. Also, move control levers back and forth several times.

To Engage Augers

- To engage augers and start throwing snow, squeeze the auger control against the left handle. Release to stop the augers.

Auger Control Test

IMPORTANT: Perform the following test before operating the snow thrower for the first time and at the start of each winter season.

Check the adjustment of the auger control as follows:

- When the auger control is released and in the disengaged “up” position, the cable should have very little slack, but should NOT be tight.



WARNING: Do not over-tighten the cable. Over-tightening may prevent the auger from disengaging and compromise the safety of the snow thrower.

- In a well-ventilated area, start the snow thrower engine as instructed earlier in this section under the heading **Starting Engine**. Make sure the throttle is set in the FAST position.
- While standing in the operator’s position (behind the snow thrower) engage the auger.
- Allow the auger to remain engaged for approximately ten (10) seconds before releasing the auger control. Repeat this several times.
- With the engine running in the FAST position and the auger control lever in the disengaged “up” position, walk to the front of the machine.
- Confirm that the auger has completely stopped rotating and shows NO signs of motion.

IMPORTANT: If the auger shows ANY signs of rotating, immediately return to the operator’s position and shut off the engine. Wait for all moving parts to stop before readjusting the auger control cable.

- To readjust the control cable, unhook the spring (found on the end of the auger cable) from the auger actuator bracket. See Figure 8.

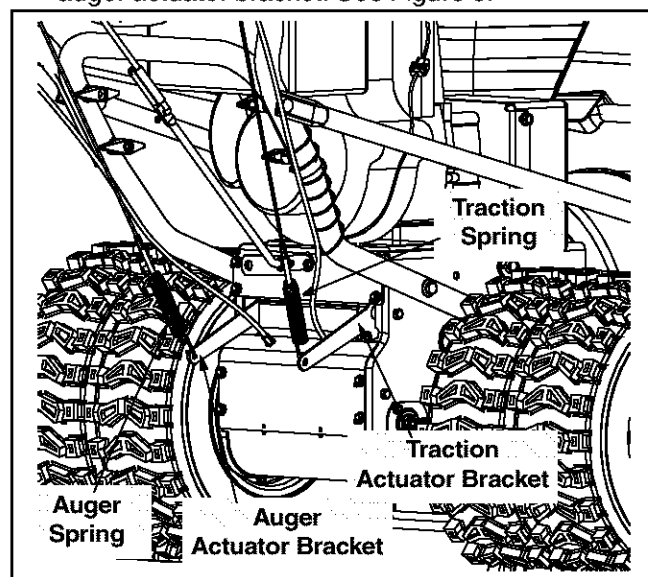

Figure 8

- Push the cable coupler through the end of the spring to expose the lock nut. See Figure 9.

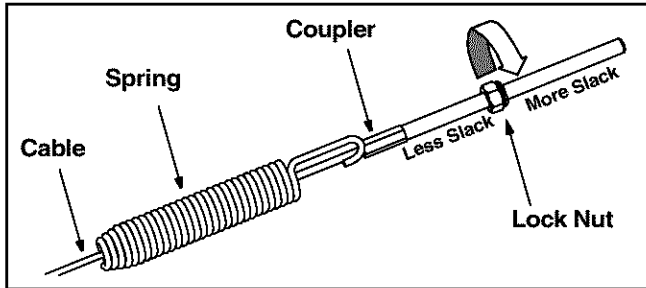

Figure 9

- Thread the lock nut outward (down the coupler) three full turns to provide more slack in the cable and reattach the spring to the bracket.
- Repeat Auger Control Test to verify proper adjustment has been achieved. Repeat the previous steps to provide more slack in the cable, if necessary.

To Engage Wheel Drive

- With the engine running near top speed, move the shift lever into one of the six FORWARD positions or two REVERSE positions. Select a speed appropriate for the snow conditions.

NOTE: Use slower speeds in heavy conditions and until you are familiar and comfortable with the operation of the snow thrower.

- Squeeze the traction control against the right handle and the snow thrower will move. Release it and the drive motion will stop.

IMPORTANT: NEVER move the shift lever without first releasing the traction control. Doing so will cause premature wear to the drive system's friction wheel.

Wheel Steering Controls

The left and right wheel steering controls are located on the underside of the handles.

- With the traction control engaged, squeeze the right wheel steering control to assist in turning right; squeeze the left control to assist in turning left.

Chute Clean-out Tool

The chute clean-out tool is conveniently fastened to the rear of the auger housing with a mounting clip (Refer to NOTE:). If the discharge chute becomes clogged during operation, proceed as follows to safely clean the chute and chute opening:

1. Release both the Auger Control Lever and the Traction/Auger Control Lock Lever.
2. Stop the engine by removing the ignition key.
3. Remove the clean-out tool from the clip which secures it to the rear of the auger housing.
4. Use the shovel-shaped end of the clean-out tool to remove any snow and ice in the discharge chute.



WARNING: Never use your hand to clear a clogged discharge chute. Shut off engine and remain behind handles until all moving parts have stopped before unclogging.

5. Refasten the clean-out tool to the mounting clip on the rear of the auger housing, re-start the engine.
6. While standing in the operator's position (behind the snow thrower), engage the auger clutch lever for a few seconds to clear any remaining snow or ice from the discharge chute before continuing to clear snow.

Operating Tips



WARNING: The temperature of the muffler and the surrounding areas may exceed 150°F. Avoid these areas.

- Allow the engine to warm up for a few minutes. The engine will not develop full power until it reaches operating temperature.
- For the most efficient snow removal, remove snow immediately after it falls.
- Discharge the snow downwind whenever possible.
- Slightly overlap each previous path.
- Set the skid shoes 1/4" below the shave plate for normal usage. The skid shoes may be adjusted upward (to lower the shave plate) for hard-packed snow. Adjust downward (to raise the shave plate) when using on gravel or crushed rock.

SECTION 5: MAKING ADJUSTMENTS



WARNING: NEVER attempt to clean chute or make any adjustments while engine is running.

Traction Control and Shift Lever

To check the adjustment of the traction control and shift lever, proceed as follows:

- Move the shift lever into sixth (6) position.
- With the traction control released, push the snow thrower forward, then pull it back. The machine should move freely.
- Engage the traction control and attempt to move the machine both forward and back, resistance should be felt.

- Move the shift lever into the fast reverse (R2) position and repeat the previous two steps.
- If you experienced resistance rolling the unit, either when repositioning the shift lever from 6 to R2 or when attempting to move the machine with the traction control released, adjust the traction control immediately. To adjust, proceed as follows:

- To readjust the control cable, unhook the traction spring (found on the end of the traction control cable) from the traction actuator bracket. See Figure 8.
- Push the cable coupler through the end of the spring to expose the lock nut. See Figure 9.
- Thread the lock nut outward (down the coupler) three full turns to provide more slack in the cable and reattach the spring to the bracket.
- Check the adjustment of the traction control as instructed earlier. Repeat the previous steps to provide more slack in the cable, in necessary.

If you are uncertain that you have reached the correct adjustment, proceed as follows:



WARNING: Drain the gasoline out of your snow thrower's engine, and place a piece of plastic film under the gas cap to avoid spillage before beginning the job.

- Tip the snow thrower forward, allowing it to rest on the auger housing.
- Remove the frame cover underneath the snow thrower by removing six self-tapping screws.
- With the traction control released, make sure there is clearance between the friction wheel and the drive plate in all positions of the shift lever.
- With the traction control lever engaged, make sure the friction wheel solidly contacts the drive plate. See Figure 10.

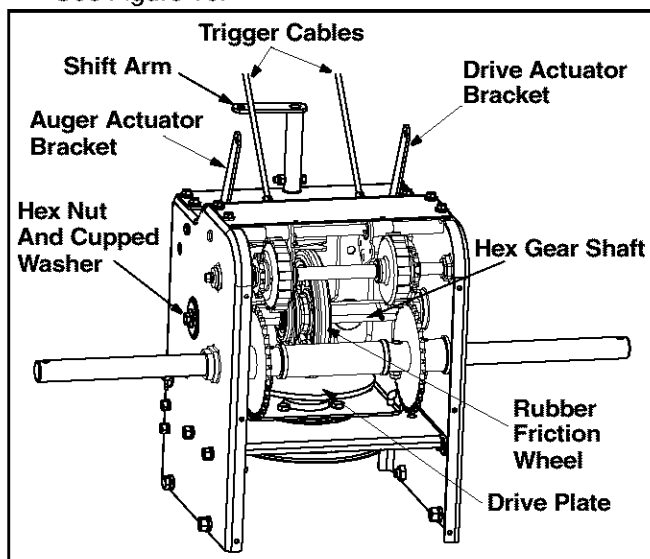

Figure 10

If adjustment is necessary, adjust traction control as instructed below:

- Thread the lock nut outward (down the coupler) to provide more slack in the cable or thread the lock nut inward (up the coupler) to provide less slack in the cable. Refer to Figure 9
- Reattach the spring to the bracket.
- Reassemble the frame cover.

NOTE: If you placed plastic film under the gas cap, be certain to remove it before operating the snow thrower.

Shift Rod

If your snow thrower is not achieving its full range of speeds, the shift rod is in need of adjustment. To adjust the shift rod, proceed as follows:

- Remove the hairpin clip and flat washer from the shift handle under the handle panel.
- Place shift lever in sixth (6) position (fastest forward speed).
- Push shift arm assembly down as far as it will go.
- Rotate the ferrule up or down on the shift rod as necessary until the ferrule lines up with the upper hole in the shift lever. See Figure 11.

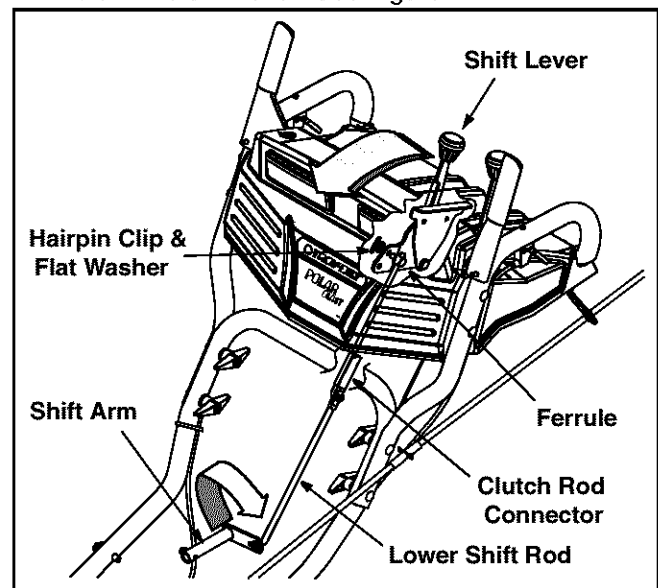

Figure 11

- Insert ferrule from the left side of the snow thrower into the upper hole.
- Reinstall the hairpin clip and the washer.

NOTE: Make certain to check for correct adjustment of the shift rod as instructed on page 10—**Traction Control and Shift Lever** before operating the snow thrower.

Auger Control

Refer to **Auger Control Test** on page 9 to adjust the auger control. Make certain to check for correct adjustment as instructed before operating the snow thrower.

Tire Pressure (Pneumatic Tires)

The tires are overinflated for shipping purposes.

- Check the tire pressure before operating the snow thrower. Refer to the tire side wall for tire manufacturer's recommended psi and deflate (or inflate) the tires as necessary.

NOTE: If the tire pressure is not equal on both sides, the unit may pull to one side or the other.



WARNING: Maximum tire pressure under any circumstance is 30 psi. Equal tire pressure should be maintained at all times. Excessive pressure (over 30 psi) when seating beads may cause tire/rim assembly to burst with force sufficient to cause serious injury

Skid Shoe Adjustment

The space between the shave plate and the ground can be adjusted by raising or lowering the skid shoes.

For close snow removal, as when using on a smooth concrete or asphalt driveway, place the skid shoes in the low position. Use the middle or high position when the area to be cleared is uneven. When operating on gravel, always put skid shoes in the high position. See Figure 12.

Adjust skid shoes as follows:

- Loosen, but do not remove, the three hex nuts which fasten the skid shoe to the auger housing.
- Raise or lower the skid shoe to desired position.
- Retighten the hex nuts loosened earlier.
- Repeat on the other side of the snow thrower.

NOTE: Make certain the bottom surface of skid shoe is flat against the ground to avoid uneven wear .

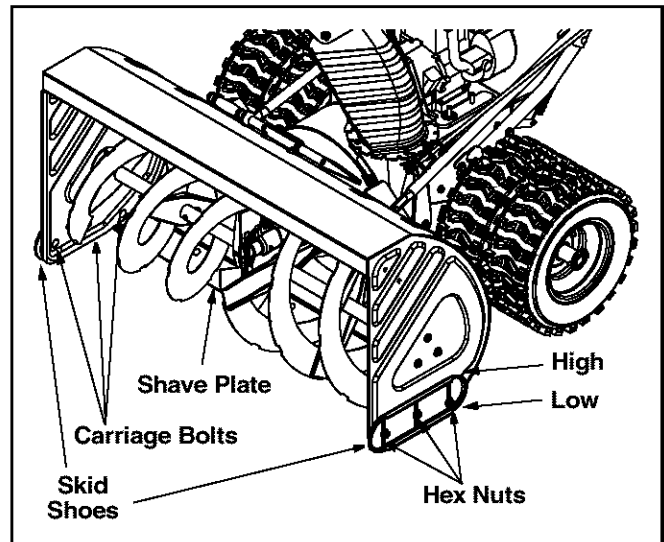

Figure 12

Chute Assembly

The distance snow is thrown can be adjusted by adjusting the angle of the chute assembly. Refer to **Chute Tilt Control** on page 6.

The remote chute control cables have been pre-adjusted at the factory. Move the remote chute lever on the control panel back and forward to adjust angle of the chute assembly.

SECTION 6: MAINTAINING YOUR SNOW THROWER



WARNING: Before lubricating, repairing, or inspecting, disengage all clutch levers and stop engine. Wait until all moving parts have come to a complete stop. Disconnect the spark plug wire and ground it against the engine to prevent unintended starting.

General Recommendations

- Always observe safety rules when performing any maintenance.
- The warranty on this snow thrower does not cover items that have been subjected to operator abuse or negligence.
- Some adjustments will have to be made periodically to maintain your unit properly.
- All adjustments in the service and adjustments sections of this manual should be checked at least once each season.

- Follow the maintenance schedule given below.
- Periodically check all fasteners and hardware to make sure these are tight.

Check V-Belts

Follow the instructions below to check the condition of the drive belts every 50 hours of operation.

- Remove the plastic belt cover on the front of the engine by removing the three self-tapping screws.
- Visually inspect for frayed, cracked, or excessively worn out belts.
- Replace belts as necessary as outlined in **SERVICING YOUR SNOW THROWER**.

Lubrication

Auger Shaft

- At least once a season, remove the shear bolts from the auger shaft and spray lubricant inside the shaft. See Figure 13.
- Grease fittings can be found at either end of the auger shaft. Lubricate with a grease gun once a season. See Figure 13.

Gear Case

The auger gear case is equipped with a grease fitting. Lubricate with Shell Alvania lead-free grease once a season (order part number 737-0168). See Figure 13.

IMPORTANT: To relieve pressure, always remove the vent plug before lubricating the gear case. Failure to do so could result in damage to the gear case seals.

Discharge Chute

The base of the discharge chute and the spirals on the chute crank should be lubricated at least every 25 hours of use. Apply the lubricant under the base of the chute and where the spirals contact the discharge chute. See Figure 14.

Drive and Shifting Mechanism

At least once a season or after every 25 hours of operation, remove rear cover. Lubricate any chains, sprockets, gears, bearings, shafts, and the shifting mechanism at least once a season. Use engine oil or a spray lubricant. Avoid getting oil on rubber friction wheel and aluminum drive plate. Refer to Figure 10.

Gear Shaft

Lubricate the gear shaft with 6-in-1 grease (part number 737-0170) at least once a season, or after every 25 hours of operation. Refer to Figure 10.

IMPORTANT: Be careful not to allow grease to get on the drive plate or rubber friction wheel.

Traction Control / Auger Control Lock

The cams on the ends of the control rods which interlock the traction drive and auger drive clutches must be lubricated at least once a season or every 25 hours of operation using a multi-purpose automotive grease. The cams can be accessed beneath the handle panel. See Figure 15.

Engine

Refer to the separate engine manual packed with your unit for all engine lubrication instructions.

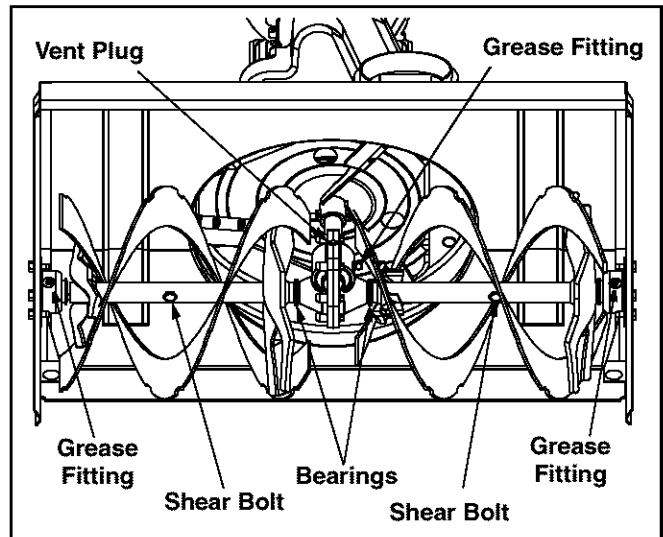

Figure 13

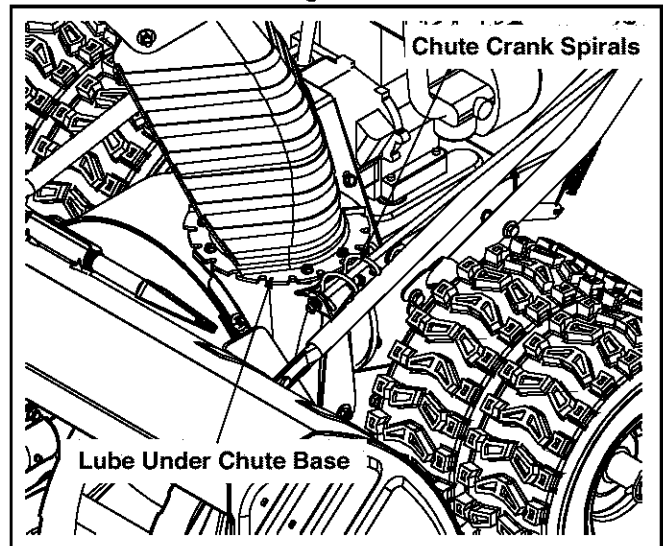

Figure 14

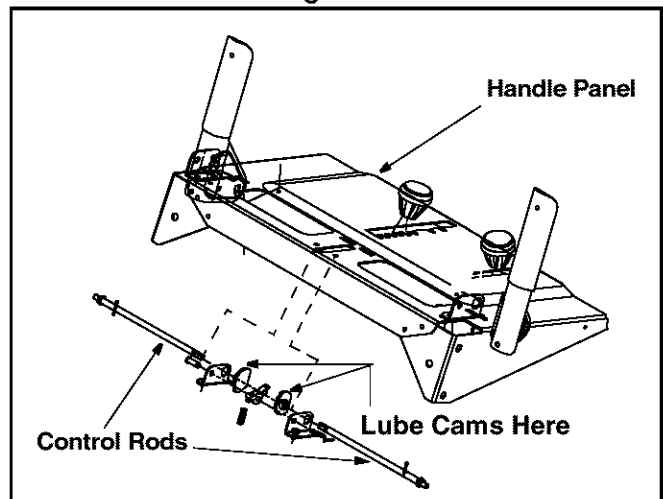

Figure 15

Check Friction Wheel Rubber

Follow the instructions below to check the condition of the friction wheel rubber every 25 hours of operation.

- Remove the six self-tapping screws from the frame cover underneath the snow thrower.
- Visually inspect the friction wheel rubber for excessive wear, cracks, or loose fit on the friction wheel drive hub.

- Also engage the traction control and check if the friction wheel is making contact with the friction plate.
- If it does not make contact, adjust the traction drive cable following instructions and recheck the friction wheel.
- Replace friction wheel rubber if necessary. Refer to instructions in Service Section.

SECTION 7: SERVICING YOUR SNOW THROWER



WARNING: Before servicing, repairing, or inspecting, disengage all clutch levers and stop engine. Wait until all moving parts have come to a complete stop. Disconnect spark plug wire and ground it against the engine to prevent unintended starting.

Augers

The augers are secured to the spiral shaft with two shear bolts and hex lock nuts. If you hit a foreign object or ice jam, the snow thrower is designed so that the bolts may shear. See Figure 16.

If the augers do not turn, check if the bolts have sheared. Two replacement shear bolts and hex lock nuts have been provided with the snow thrower. Refer to **Loose Parts** on page 5.

IMPORTANT: NEVER replace the auger shear bolts with standard hex bolts. Any damage to the auger gearbox or other components, as a result of doing so, will NOT be covered by your snow thrower's warranty.

Shave Plate and Skid Shoes

The shave plate and skid shoes on the bottom of the snow thrower are subject to wear. They should be checked periodically and replaced when necessary.

NOTE: *The skid shoes on this machine have two wear edges. When one side wears out, they can be rotated 180° to use the other edge.*

- Remove the six carriage bolts (three per side), bell washers and hex nuts which secure the skid shoes to the snow thrower on either side. See Figure 12.
- Reassemble new skid shoes with the hardware removed earlier (cupped side of bell washer against the skid shoes). Make certain the skid shoes are adjusted to be level. Refer to Figure 12.
- To remove the shave plate, remove the carriage bolts, bell washers and hex nuts which secure the shave plate to the snow thrower housing. See Figure 16.

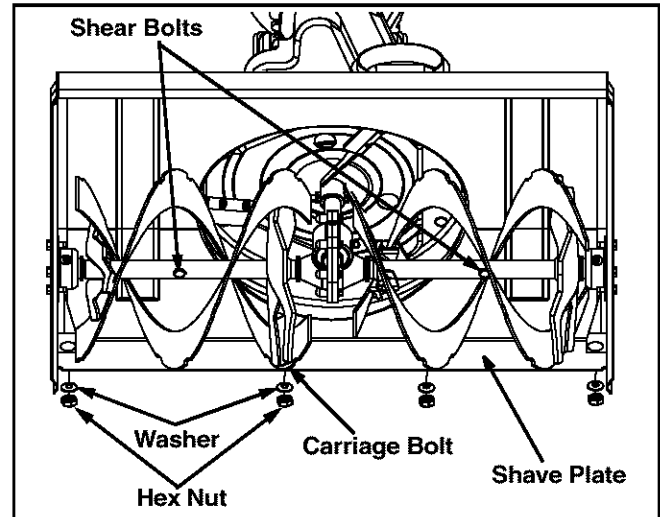

Figure 16

- Reassemble the new shave plate, making sure heads of carriage bolts are to the inside of the housing.

Replacing Belts

To remove and replace either the auger belt or the drive belt, follow the steps below and then proceed to the specific steps listed under respective sub-headings.

- Disconnect the chute crank assembly at the discharge chute end by removing the hairpin clip and the two flat washers.
- Remove the plastic belt cover, located near the engine, by removing the three self-tapping screws and flat washers that secure it. See Figure 17.
- Remove the large shoulder bolt and washer on the left hand side of the engine pulley. See Figure 18.

Auger Belt

- Remove the cotter pin and washer from the ferrule in order to disconnect the auger idler rod from the brake bracket assembly. See Figure 19.
- Slip the auger control belt (the front belt) off the engine pulley.

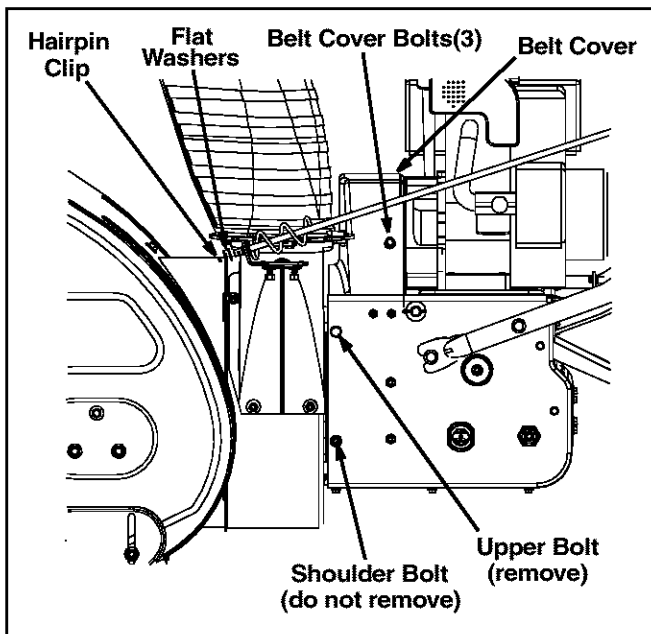

Figure 17

- Pull the brake bracket assembly towards the cable guide roller and unhook the auger cable “Z” fitting.
- Remove the upper bolts and lock washers which secure the auger housing assembly to the frame assembly using a 9/16” wrench.
- Separate the auger housing from the frame assembly by tilting the housing forward and pulling up the handles.
- Using a 1/2” wrench, remove the hex screw and bell washer from the center of the pulley on the auger housing. Lift the brake bracket assembly out of the pulley groove and remove the pulley. Be careful not to lose the key. See Figure 20.
- Remove and replace auger belt inside belt keepers.
- Reassemble pulley to auger housing with hex screw and bell washer (cupped side toward the pulley). Make sure key is in place on shaft and brake puck is seated in the pulley groove.
- Reassemble the belt cover and chute directional control.

Proper Adjustment: With the auger clutch lever in the disengaged position the top surface of the new belt should be even with the outside diameter of the pulley.

- To adjust, disconnect ferrule from brake bracket assembly and thread ferrule in (towards idler) to increase tension on belt, and out to decrease tension.

NOTE: The brake puck must always be firmly seated in the pulley groove when the auger control is in the disengaged position.

Drive Belt

- Unhook the extension spring from the belt cover plate. See Figure 21.
- Remove drive belt from the engine pulley and bottom drive pulley. Refer to Figure 21

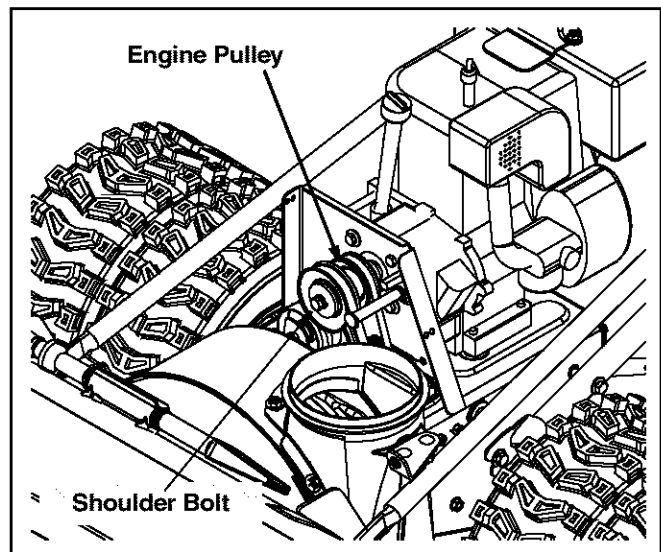

Figure 18

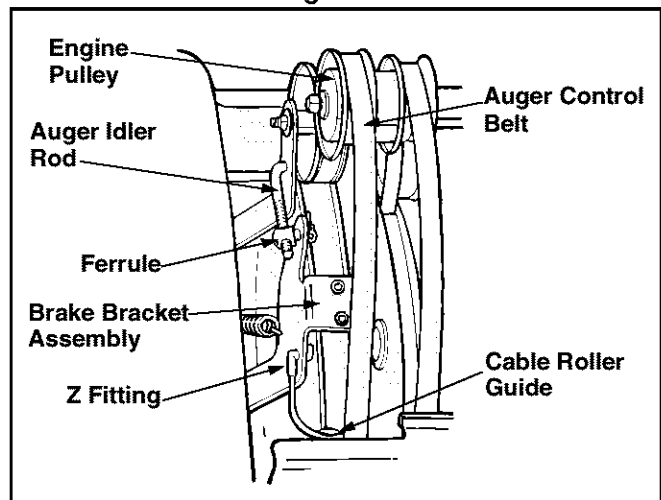

Figure 19

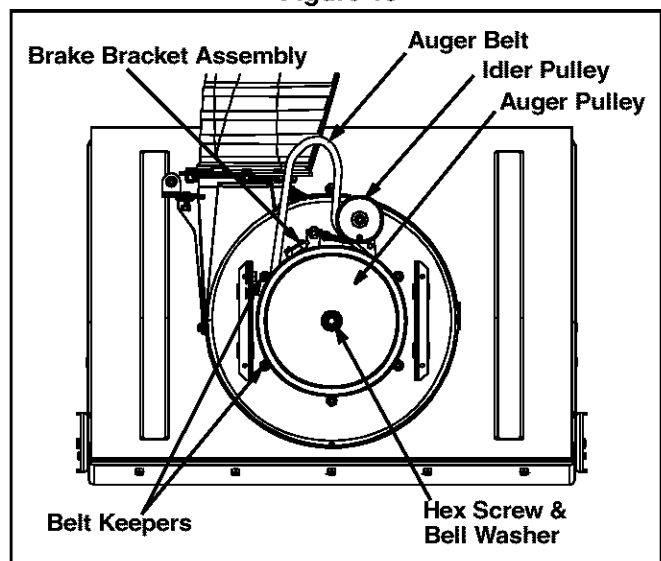

Figure 20

- Replace belt and reassemble in reverse order.

- Reassemble the two halves of the unit hooking the lower portion of the auger housing over the stationary shoulder bolts in the frame assembly.

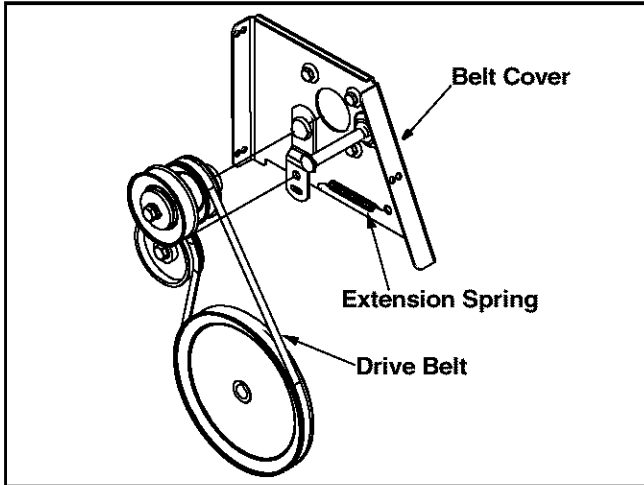

Figure 21

- Secure the two halves with the two bolts and lock washers removed earlier. Refer to Figure 18.
- Attach the "Z" fitting of the cable into the brake bracket assembly. Refer to Figure 19.
- Slip the auger control belt over engine pulley.
- Insert ferrule on auger idler rod into bracket assembly and secure with flat washer and cotter pin. Reassemble the large shoulder bolt and lock washer as shown in Figure 18.
- Reassemble belt cover and chute crank.

Changing Friction Wheel Rubber

The rubber on the friction wheel is subject to wear and should be checked after the first 25 hours of operation, and periodically thereafter. Replace the friction wheel rubber if any signs of wear or cracking are found.

- Drain the gasoline from the snow thrower, or place a piece of plastic under the gas cap.
- Tip the snow thrower up and forward, so that it rests on the housing.
- Remove six screws from the frame cover underneath the snow thrower.
- Remove the left wheel from the axle.
- Using a 7/8" wrench, hold the hex shaft and remove the hex bolts and bell washer and bearing from left side of the frame. See Figure 22.
- Holding the friction wheel assembly, slide the hex shaft out of the left side of the unit. The spacer on the right side of the hex shaft will fall and the sprocket should remain hanging loose in the chain.
- Lift the friction wheel assembly out between the axle shaft and the drive shaft assemblies.
- Remove the four screws which secure the friction wheel rubber between the friction wheel plates. See Figure 22.
- Discard the old friction wheel rubber.

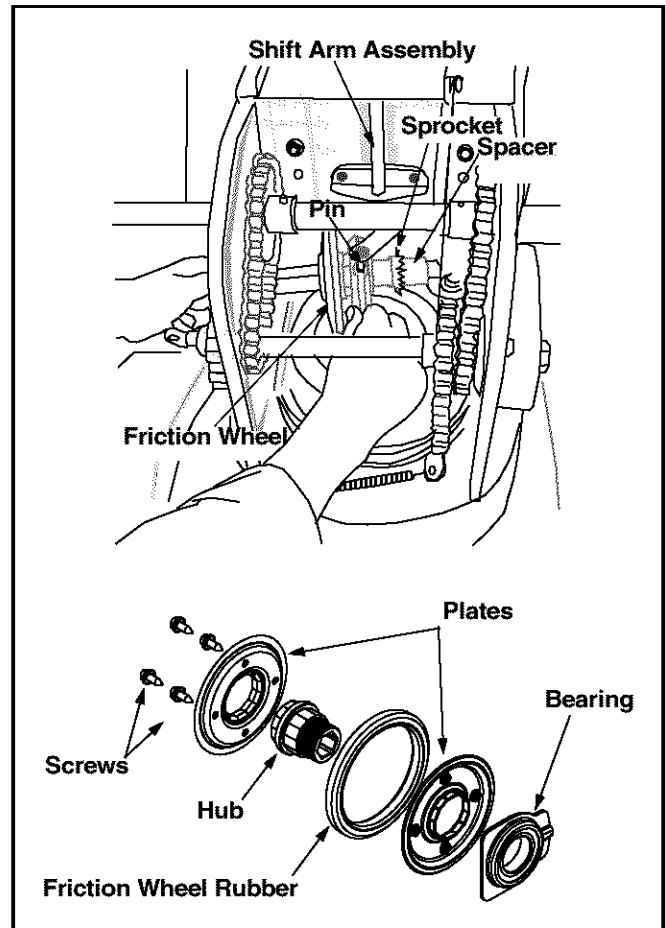

Figure 22

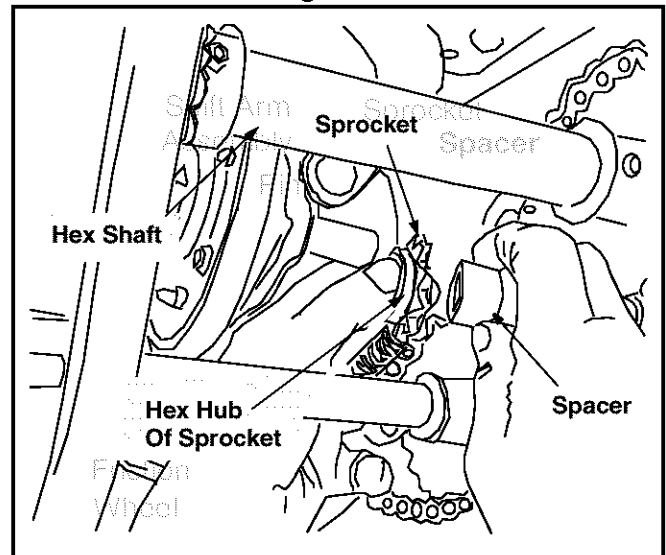

Figure 23

- Reassemble the new friction wheel rubber to the friction wheel assembly, tightening the four screws in rotation and with equal force.
- Insert the pin from the shift arm assembly into the friction wheel assembly and hold assembly in position. See Figure 23.
- Slide the hex shaft through the left side of the housing and through the friction wheel assembly.

- Insert the hex shaft through the sprocket and the spacer. Make certain that the chain engages both the large and the small sprocket.

NOTE: If the sprocket fell from the snow thrower while removing the hex shaft, place the sprocket on the hex shaft. Position the hex hub of the sprocket toward the friction wheel when sliding the sprocket on to the hex shaft. See Figure 23.

- Secure with the bell washer and hex bolt removed earlier.
- Secure the frame cover with six self-tapping screws. Put the snow thrower down to its normal operating position.

NOTE: If you placed plastic film under the gas cap, be certain to remove it.

Off-season Storage



WARNING: Never store engine with fuel in tank indoors or in poorly ventilated areas, where fuel fumes may reach an open flame, spark or pilot light as on a furnace, water heater, clothes dryer or other gas appliance.

- If unit is to be stored over 30 days, prepare engine for storage as instructed in the engine manual.
- Remove all debris from the exterior of equipment.
- Follow lubrication recommendations on page 13.
- Always store the snow thrower in a clean, dry area.

NOTE: When storing any type of power equipment in an unventilated or metal storage shed, care should be taken to rust proof the equipment. Using a light oil or silicone, coat the equipment, especially any chains, springs, bearings and cables.

SECTION 8: TROUBLESHOOTING

Problem	Cause	Remedy
Engine fails to start.	<ol style="list-style-type: none"> 1. Fuel tank empty, or stale fuel. 2. Blocked fuel line. 3. Choke not in ON position 4. Faulty spark plug. 5. Safety key not in ignition switch on engine. 6. Spark plug wire disconnected. 7. Primer button not being used properly. 	<ol style="list-style-type: none"> 1. Fill tank with fresh gasoline. 2. Clean the fuel line. 3. Move switch to ON position 4. Clean, adjust gap or replace. 5. Insert the key fully into the switch. 6. Connect spark plug wire. 7. Refer to the engine manual.
Engine runs erratic.	<ol style="list-style-type: none"> 1. Unit running on CHOKE. 2. Blocked fuel line or stale fuel. 3. Water or dirt in fuel system. 4. Carburetor out of adjustment. 	<ol style="list-style-type: none"> 1. Move choke lever to OFF position. 2. Clean fuel line and fill tank with clean, fresh gasoline. 3. Drain fuel tank and carburetor. Refill with fresh fuel. 4. Refer to the engine manual.
Loss of power.	<ol style="list-style-type: none"> 1. Spark plug wire loose. 2. Gas cap vent hole plugged. 3. Exhaust port plugged. 	<ol style="list-style-type: none"> 1. Connect and tighten spark plug wire. 2. Remove ice and snow from gas cap. Be certain vent hole is clear. 3. Refer to the engine manual.
Engine overheats.	<ol style="list-style-type: none"> 1. Carburetor not adjusted properly. 	<ol style="list-style-type: none"> 1. Refer to the engine manual or have the carburetor adjusted by an authorized engine service dealer.
Excessive vibration.	<ol style="list-style-type: none"> 1. Loose parts or damaged auger. 	<ol style="list-style-type: none"> 1. Stop engine immediately and disconnect spark plug wire. Tighten all bolts and nuts. If vibration continues, have unit serviced by an authorized service dealer.
Unit fails to propel itself.	<ol style="list-style-type: none"> 1. Traction control cable in need of adjustment. 2. Drive belt loose or damaged. 	<ol style="list-style-type: none"> 1. Adjust traction control cable. Refer to Adjustments. 2. Replace drive belt.
Unit fails to discharge snow.	<ol style="list-style-type: none"> 1. Discharge chute clogged. 2. Foreign object lodged in auger. 3. Auger control cable in need of adjustment. 4. Auger belt loose or damaged. 5. Shear bolt(s) sheared. 	<ol style="list-style-type: none"> 1. Stop engine immediately and disconnect spark plug wire. Clean discharge chute and inside of auger housing. 2. Stop engine immediately and disconnect spark plug wire. Remove object from auger. 3. Refer to Auger Control Test on Page 9. 4. Refer to Adjustments. 5. Replace shear bolt(s).

NOTE: For repairs beyond the minor adjustments listed above, contact an authorized Troy-Bilt service dealer.

SECTION 9: MODEL 13045 PARTS LIST

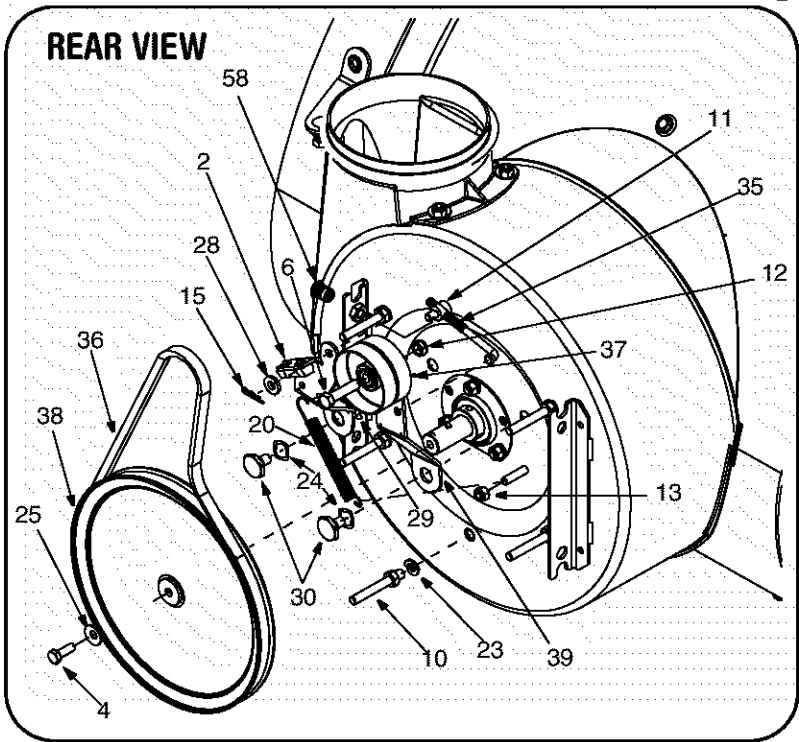
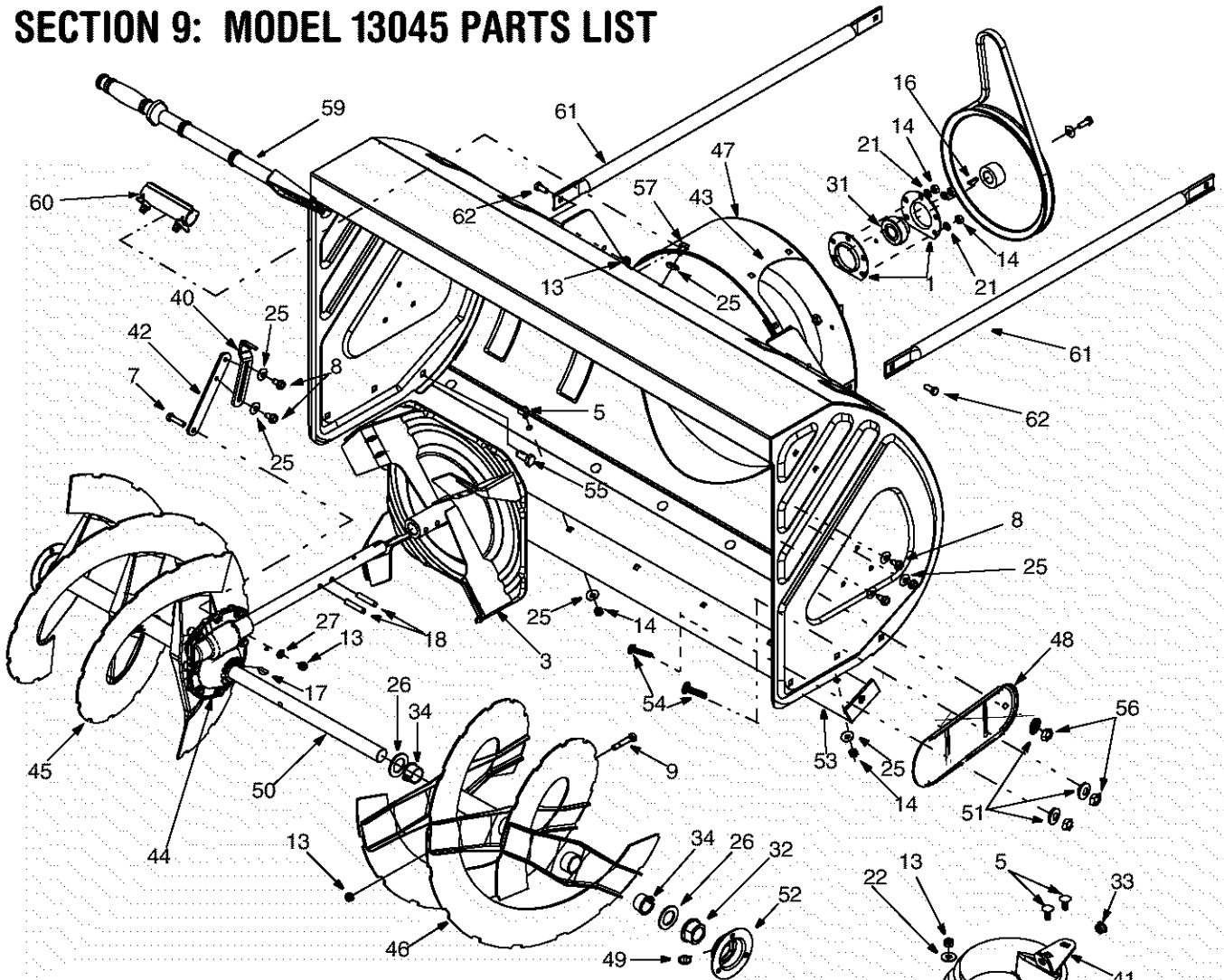

Model 13045

Ref. No.	Part No.	Part Description	Ref. No.	Part No.	Part Description
1.	05244A	Bearing Housing	33.	741-0475	Plastic Bushing
2.	618-0281A	Bracket Assembly, Auger Break	34.	741-0494	Flange Bushing
3.	684-0090A	Impeller Assembly, 16"	35.	747-0980	Idler Rod, Auger
4.	710-0371	Hex Lock Bolt 5/16-18 x .875"	36.	754-0222A	V-Belt
5.	710-0451	Carriage Bolt 5/16-18 x .750"	37.	756-0178	Flat Idler
6.	710-0459A	Hex Screw, Special 3/8-24 x 1.5"	38.	756-0243	Pulley
7.	710-0528	Hex Screw 5/16-18 x 1.25"	39.	784-0385A	Idler Bracket, Auger
8.	710-0604A	Self-Tapp. Screw 5/16-18 x .625"	40.	784-5076	Support Bracket
9.	710-0891	Shear Bolt 5/16-18 x 1.75"	41.	784-5123	Chute Crank Bracket
10.	711-0640	Stud	42.	784-5710	Support Plate
11.	711-0677	Ferrule	43.	784-5711	Chute Bracket
12.	712-0116	Jam Nut 3/8-24	44.	618-0436	Gear Assembly
13.	712-0429	Hex Lock Nut 5/16-18	45.	684-0072	Spiral Assembly RH
14.	712-3010	Hex Nut 5/16-18	46.	684-0073	Spiral Assembly LH
15.	714-0104	Hairpin Clip	47.	684-04008	Auger Housing Assembly, 45"
16.	714-0126	Key	48.	784-5697	Slide Shoe
17.	714-0135	Key	49.	737-3000	Lube Fitting
18.	715-0118	Spiral Pin	50.	738-0492	Spiral Axle
19.	731-1696	Chute Adapter	51.	736-0105	Bell Washer
20.	732-0858	Extension Spring	52.	784-0315	Bearing Housing
21.	736-0119	Lock Washer	53.	784-5696B	Shave Plate, 45"
22.	736-0159	5/16 Washer	54.	710-0389	Carriage Screw
23.	736-0169	Lock Washer	55.	710-3168	Carriage Bolt
24.	736-0174	Wave Washer	56.	712-0798	Hex Nut 3/8-16
25.	736-0242	Beleville Washer	57.	710-1260A	Screw, 5/16-18 x .75
26.	736-0250	Flat Washer	58.	712-0717	Insert Nut, 3/8-16
27.	736-0271	Spring Washer	59.	731-2643	Chute Clean-out Tool
28.	736-3008	Flat Washer	60.	731-2635	Mount, Chute Clean-out Tool
30.	738-0281	Shoulder Screw	61.	748-1117	Support Tube
31.	741-04024	Self-Aligning Bearing	62.	710-3008	Screw, 5/16-18 x .75"
32.	741-0192	Flange Bearing w/ Flats			

Model 13045

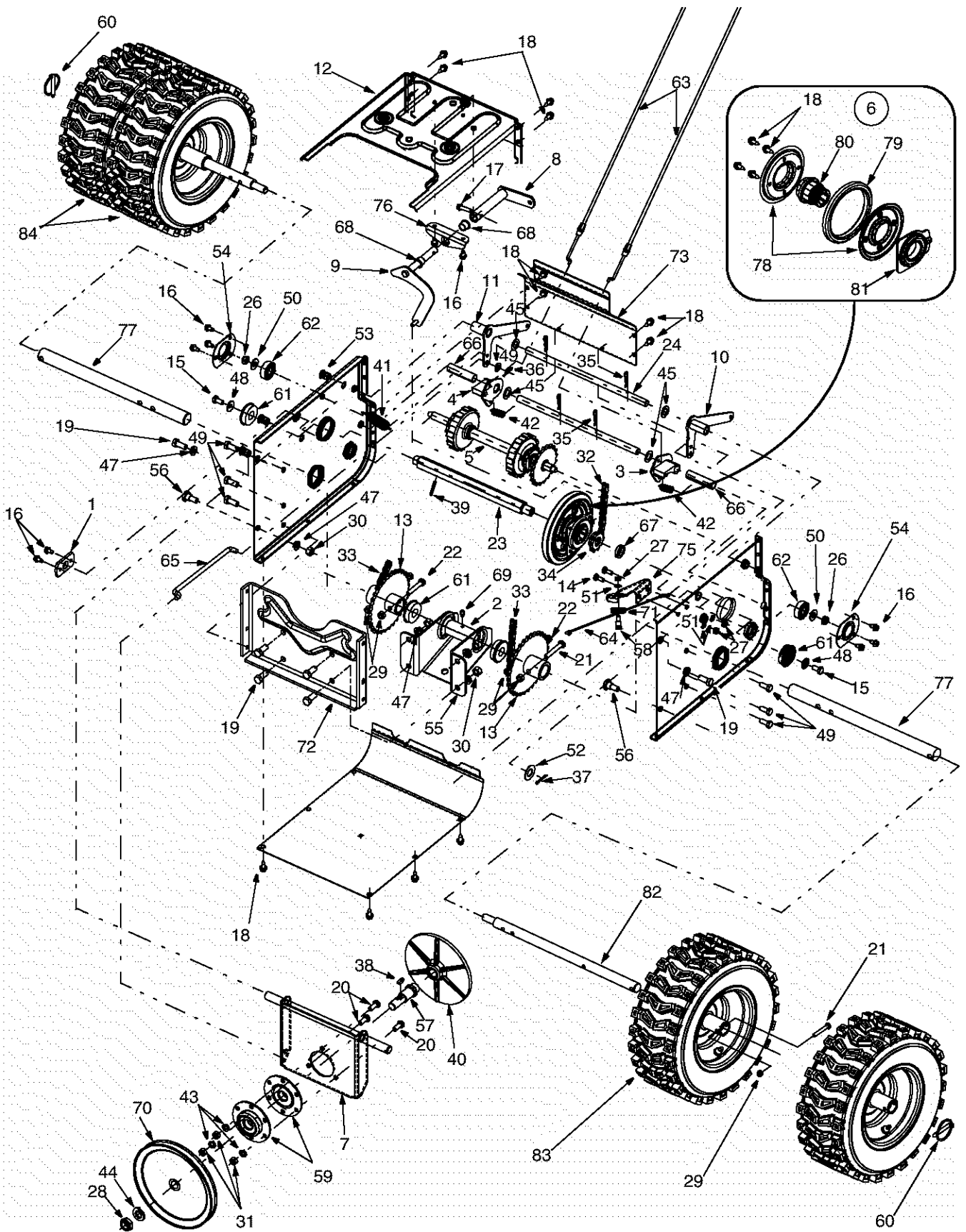

Model 13045

Ref. No.	Part No.	Part Description	Ref. No.	Part No.	Part Description
1.	05523	Pivot Support Bracket	46.	736-0163	Flat Washer
2.	750-1302A	Spacer, .6725 x 1.125 x 2.485	47.	736-0217	Lock Washer
3.	618-0279	Dogg Assembly LH	48.	736-0242	Bell Washer
4.	618-0280	Dogg Assembly RH	49.	710-0604A	Self-tapping Screw, 5/16-18 x .625
5.	618-0282B	Shaft Assembly	50.	736-0300	Flat Washer
6.	618-0296A	Friction Wheel Assembly	51.	736-0329	Lock Washer
7.	684-0162	Support Bracket Assembly	52.	736-0623	Flat Washer
8.	684-0161	Shift Arm Assembly	53.	712-0717	Nut Insert, 3/8-16
9.	684-0117	Shift Rod Assembly	54.	784-0404	Bearing Retainer Bracket
10.	684-0118	Auger Actuator Bracket Assy.	55.	784-0407	Axle Bearing Support Bracket
11.	684-0119	Drive Actuator Bracket Assy.	56.	738-0143	Shoulder Screw
12.	684-0120	Frame Assembly	57.	738-0279	Spindle, Drive Plate
13.	684-0122	Sprocket Assembly	58.	738-0924	Shoulder Screw 1/4-28 x .375"
14.	710-0195	Hex Screw, 1/4-28 x .625"	59.	741-0163A	Bearing Housing Assembly
15.	710-0538	Hex Screw, 5/16-18 x .625"	60.	714-0151A	Click Pin
16.	710-0599	Self-tapping Screw, 1/4-20 x .5	61.	741-0563	Ball Bearing
17.	710-0788	Self-tapping Screw, 1/4-20 x 1"	62.	741-0747	Ball Bearing
18.	710-1652	Self-tapping Screw, 1/4-20 x .625"	63.	746-0949A	Steer Cable
19.	710-3001	Hex Screw 3/8-16 x .880"	64.	746-0951	Auger Idler Cable
20.	710-3008	Hex Screw 5/16-18 x .75"	65.	747-0973	Drive Clutch Rod
21.	710-3103	Hex Screw 5/16-18 x 2"	66.	750-0903	Split Spacer
22.	710-3180	Hex Screw 5/16-18 x 1.75"	67.	750-0997	Spacer
23.	711-1191	Hex Shaft, Drive	68.	741-0748	Flange Bearing
24.	711-1193	Actuator Shaft	69.	737-3000	Lube Fitting, 3/16
25.	711-1194	Actuator Drive Shaft	70.	756-0344	Drive Pulley
26.	712-0116	Lock Nut	71.	756-0625	Roller Cable
27.	712-0138	Hex Nut 1/4-28	72.	784-0406	Frame Support Bracket
28.	712-0221	Jam Lock Nut	73.	784-0379	Frame Cover, Upper
29.	712-0429	Hex Lock Nut	74.	784-0380	Frame Cover, Lower
30.	712-0798	Hex Nut 3/8-16	75.	784-0384	Auger Cable Bracket
31.	712-3010	Hex Nut 5/16-18	76.	784-0403	Shift Bracket
32.	713-0284	Chain	77.	738-0975	Wheel Axle
33.	713-0286	Chain	78.	784-5617A	Friction Plate
34.	713-0413	Sprocket	79.	735-0243B	Friction Wheel Rubber
35.	714-0101	Hairpin Clip	80.	718-0301A	Friction Wheel Hub
36.	714-0104	Hairpin Clip	81.	618-0063A	Friction Wheel Bearing
37.	714-0115	Cotter Pin	82.	738-1166A	Wheel Axle
38.	714-0388	Key	83.	634-0225-662	Wheel Assembly, LH*
39.	715-0249	Roll Pin	—	734-2031	X-Trac Tire Only
40.	717-0302	Drive Plate	—	734-1124	Rim Only
41.	732-0121	Extension Spring	—	734-0255	Air Valve Only
42.	732-0209	Extension Spring	84.	634-0226-662	Wheel Assembly, RH*
43.	736-0119	Lock Washer 5/16	—	734-2031	X-Trac Tire Only
44.	736-0158	Lock Washer 5/8	—	734-1124	Rim Only
45.	736-0160	Flat Washer	—	734-0255	Air Valve Only

*Note: Two wheel assemblies are found on both the left-hand & right-hand sides.

Model 13045

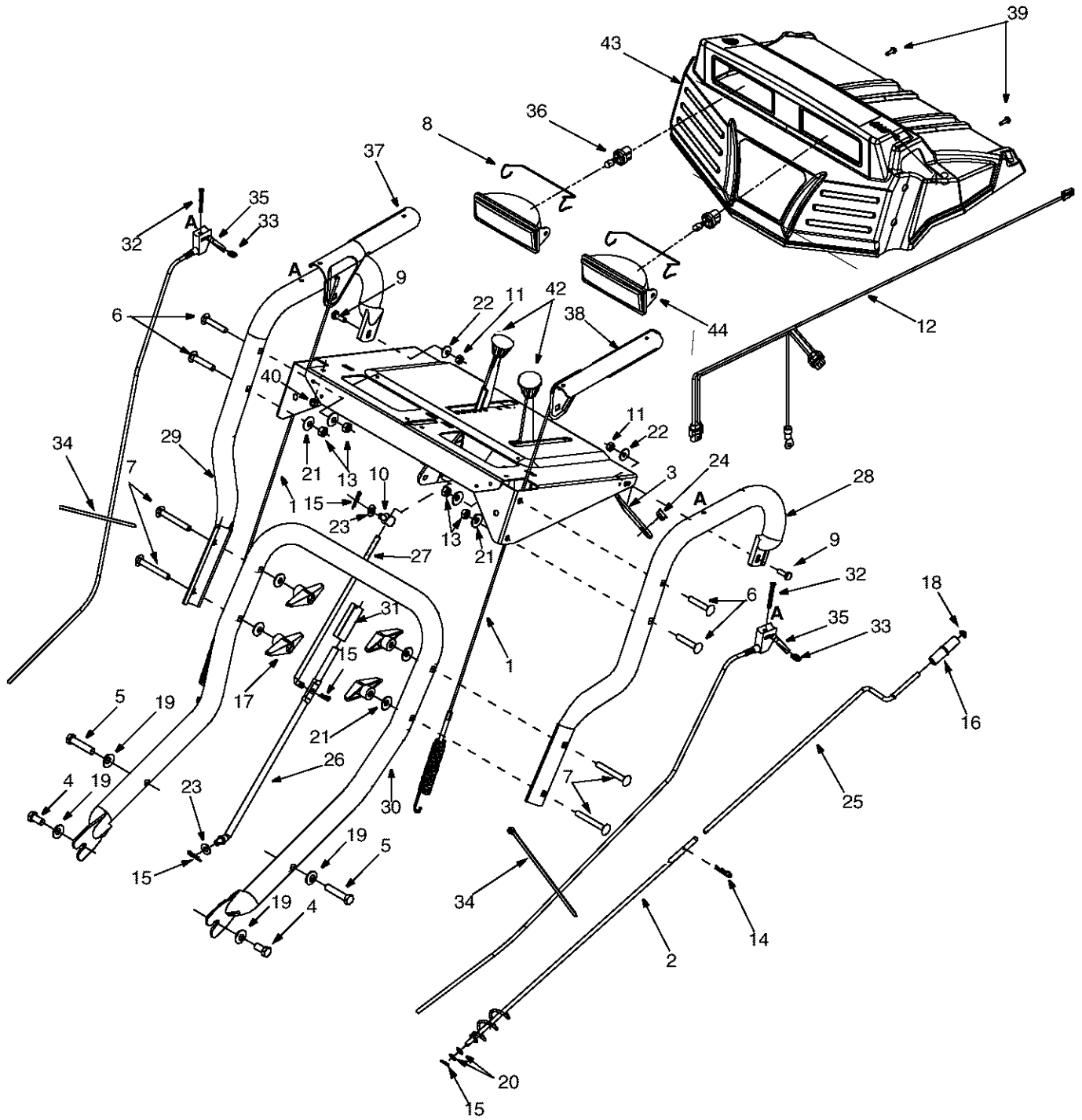

Ref. No.	Part No.	Part Description
1.	646-0012	Cable Assembly, Auger/Drive
2.	684-0053B	Chute Crank Assembly, Lower
3.	705-5266	Chute Crank Bracket
4.	710-1879	Hex Screw, 3/8-16 x .88"
5.	710-1878	Hex Screw, 3/8-16 x 1.75"
6.	710-0458	Carriage Bolt 5/16-18 x 1.75"
7.	710-0572	Carriage Bolt 5/16-18 x 2.5"
8.	747-1136	Lamp Retainer
9.	710-3015	Hex Screw 1/4-20 x .75"
10.	711-0677	Ferrule
11.	712-0287	Hex Nut 1/4-20
12.	629-04010	Lamp Wire Harness
13.	712-3010	Hex Nut
14.	714-0101	Hairpin Clip
15.	714-0104	Hairpin Clip
16.	720-0201A	Chute Crank Knob
17.	720-0284	Knob
18.	726-0100	Push Cap
19.	736-0105	Bell Washer
20.	736-0185	Flat Washer
21.	736-0242	Beleville Washer
22.	736-0270	Bell Washer
23.	736-0275	Flat Washer
24.	741-0475	Plastic Bushing
25.	747-0624	Chute Crank
26.	747-0983	Lower Shift Rod
27.	747-0997	Upper Shift Rod
28.	749-0989A	Upper Handle LH
29.	749-0990A	Upper Handle RH
30.	749-0991	Lower Handle
31.	750-0963	Clutch Rod Connector
32.	710-1625	Oval C-Sunk Screw
33.	712-0127	Flat Weld Nut
34.	725-0157	Cable Tie
35.	746-0950	Trigger Control
36.	725-1658	Halogen Lamp
37.	705-5218	Handle Engagement RH
38.	705-5219	Handle Engagement LH
39.	710-1003	Special B Screw
40.	712-0271	Hex Sems Nut
41.	712-0429	Hex Lock Nut
42.	720-0232	Shift Knob
43.	731-04069	Handle Panel
44.	725-1672	Lens Assembly

Model 13045

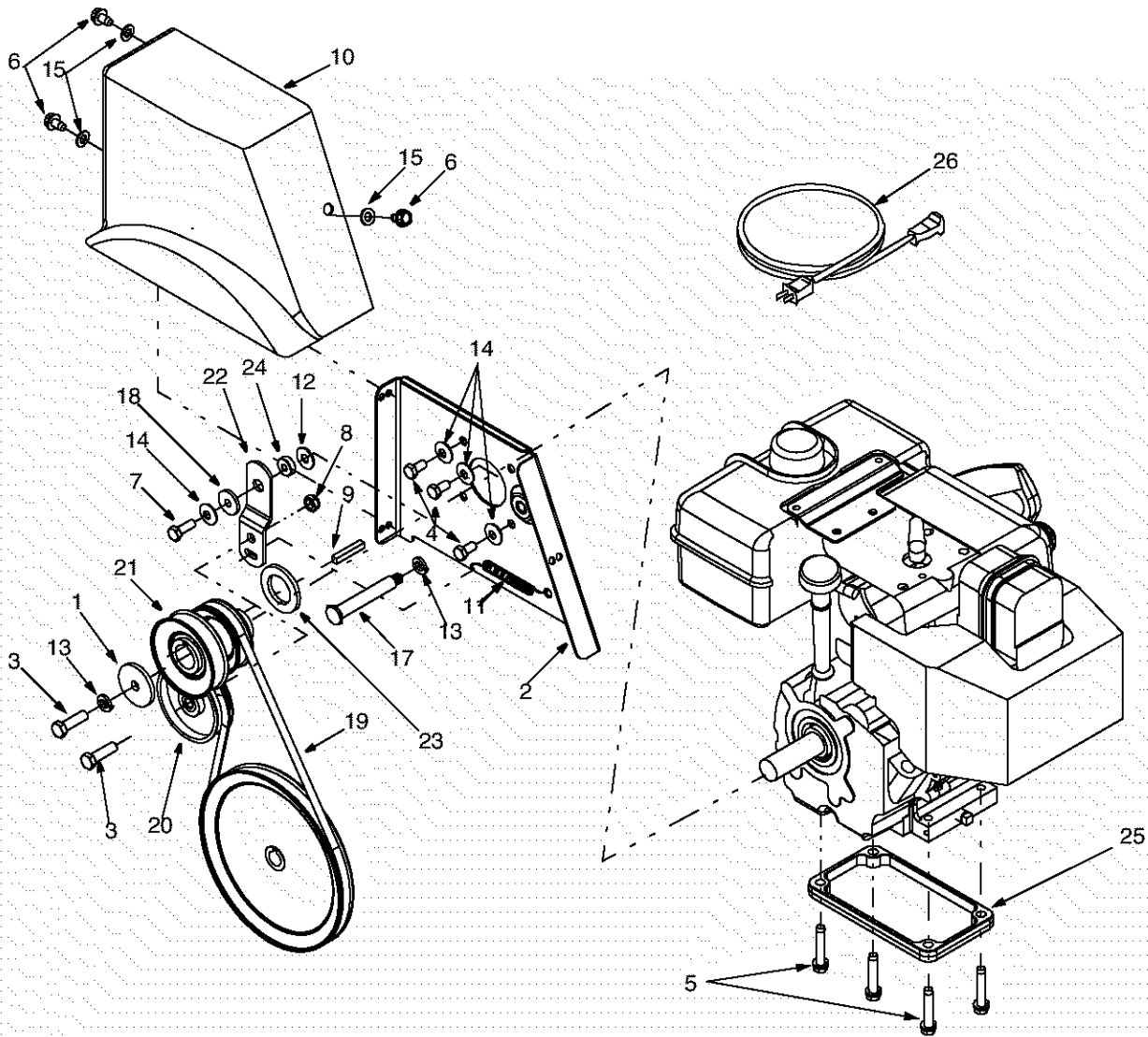

Ref. No.	Part No.	Description	Ref. No.	Part No.	Description
1.	07386	Washer	14.	736-0242	Beleville Washer
2.	684-0123A	Belt Cover Bracket Assembly	15.	736-0264	Flat Washer
3.	710-0191	Hex Screw 3/8-24 x 1.25"	17.	738-0982	Shoulder Screw
4.	710-0237	Hex Screw 5/16-24 x .625"	18.	748-0234	Shoulder Spacer
5.	710-1008	Self-tapping Sems Screw	19.	754-0131	V-Belt
6.	710-0607	TT Screw 5/16-18 x 0.5"	20.	756-0240	Flat Idler
7.	710-0672	Hex Lock Screw 5/16-24 x 1.25"	21.	756-0241B	Double Pulley
8.	712-0116	Jam Nut	22.	784-5726	Idler Bracket
9.	714-0118	Key	23.	750-1148A	Spacer
10.	731-2531	Belt Cover	24.	748-0418	Spacer, .33 x 1.0 x .36
11.	732-0303	Extension Spring	25.	717-0882A	Spacer
12.	736-0159	5/16 Washer	26.	629-0071	Extension Cord, 110V, 3-prong
13.	736-0217	Lock Washer			

Model 13045

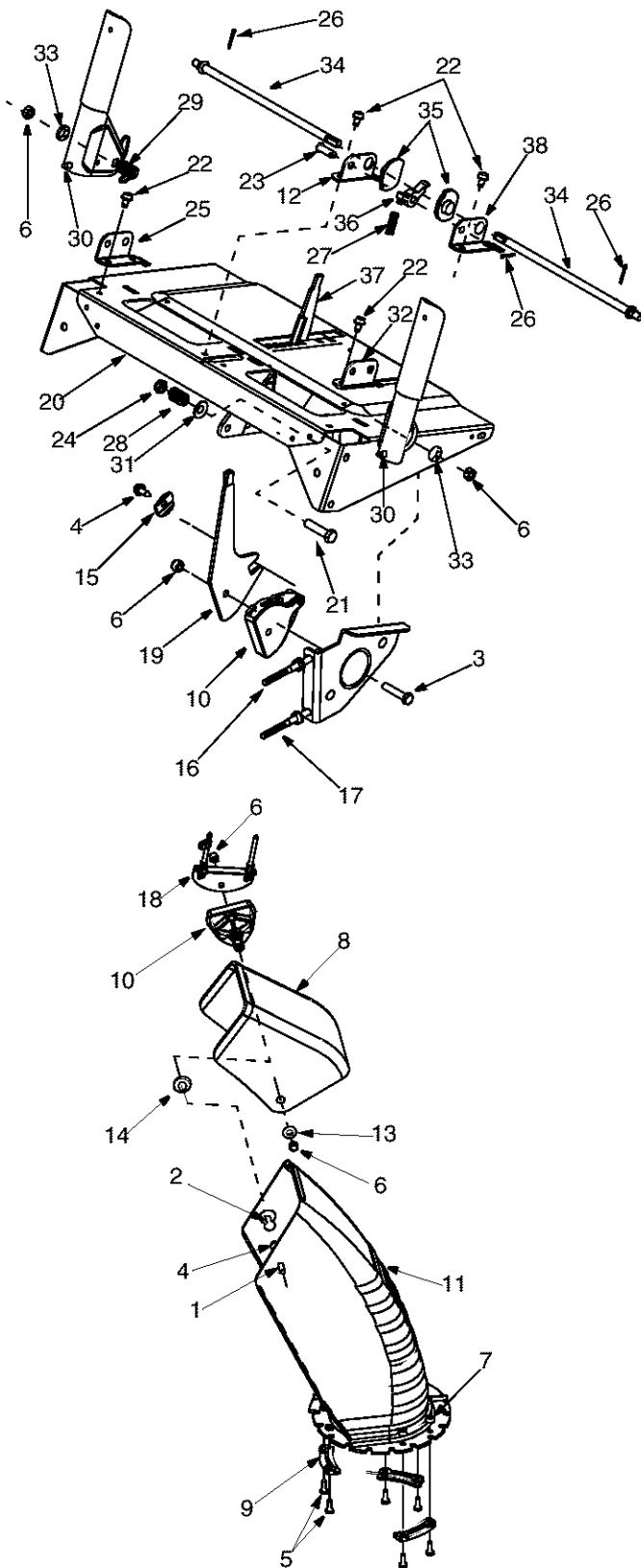

Ref. No.	Part No.	Description
1.	710-0276	Carriage Screw
2.	710-0458	Carriage Bolt 5/16-18 x 1.75"
3.	710-0805	Hex Bolt 5/16-18 x 1.5"
4.	710-0896	Hex AB Screw 1/4-14 x .625"
5.	710-3015	Hex Screw 1/4-20 x .75"
6.	712-0429	Hex Lock Nut
7.	712-3027	Hex Flange Lock Nut
8.	731-0846C	Upper Chute
9.	731-0851A	Chute Flange Keeper
10.	731-1313C	Cable Guide, Chute Tilt
11.	731-0903D	Lower Chute
12.	784-5680	Handle Suppt. Bracket 5/8 RH
13.	736-0159	5/16 Washer
14.	736-0231	Flat Washer
15.	736-0506	Special Washer
16.	746-0902	Chute Control Cable
17.	746-0903	Chute Cable w/Clip
18.	784-5594	Cable Bracket
19.	784-5604	Chute Tilt Handle
20.	684-0102	Handle Panel Assembly w/ Tilt
21.	710-0459A	Hex Bolt 3/8-24 x 1.5"
22.	710-0599	TT Screw 1/4-20 x 0.5"
23.	711-0653	Clevis Pin
24.	712-0116	Jam Nut
25.	784-5682	Handle Suppt. Bracket 3/8 RH
26.	714-0104	Cotter Pin
27.	732-0145	Spring
28.	732-0193	Spring
29.	732-0746	Torsion Spring
30.	735-0199A	Rubber Bumper
31.	736-0105	Bell Washer
32.	784-5681	Handle Suppt. Bracket 3/8 LH
33.	736-0509	Special Washer
34.	747-0877	Cam Rod
35.	748-0362	Cam, Handle Lock
36.	748-0363	Pawl, Handle Lock
37.	784-5619A	Shift Handle
38.	784-5679	Handle Suppt. Bracket 5/8 LH

Model 13045

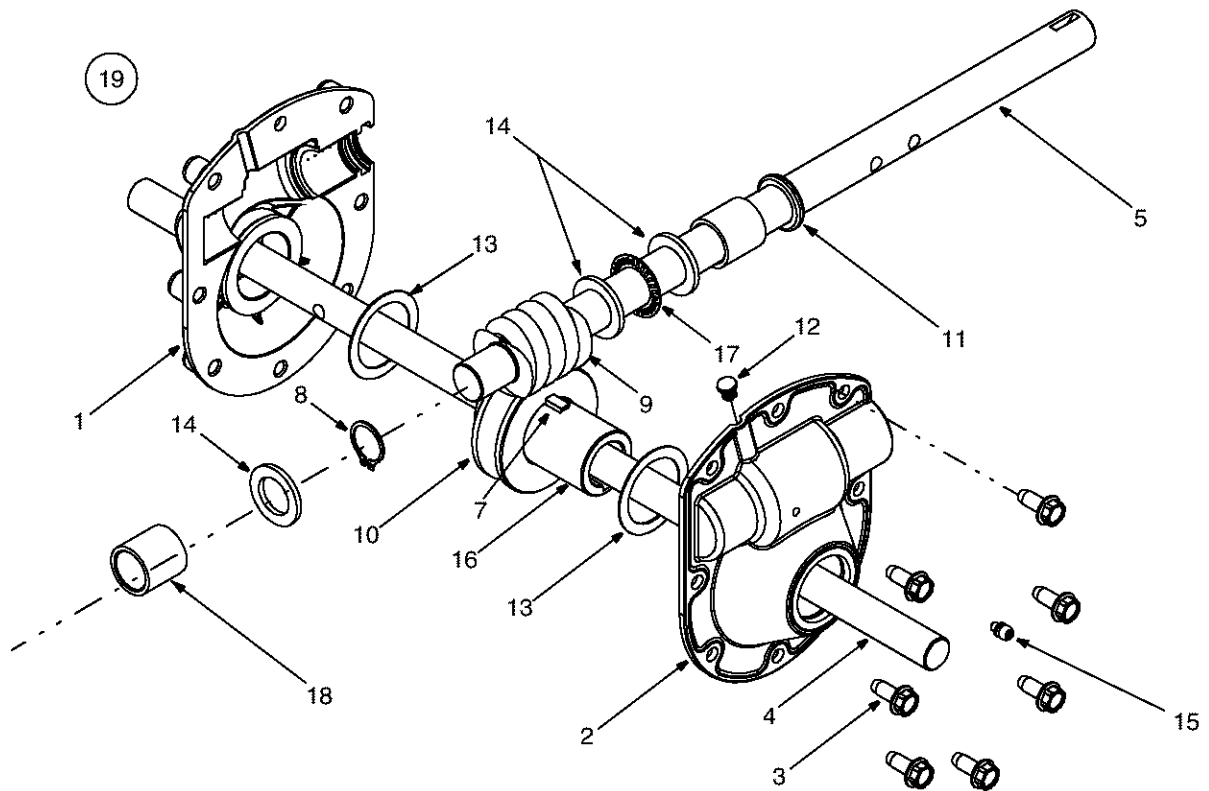

Ref. No.	Part No.	Description
1.	618-0246	Housing Assembly, RH
2.	618-0435	Housing Assembly, LH
3.	710-1260A	Screw, 5/16-18 x 0.75
4.	711-0908A	Axle, Auger
5.	711-1133	Shaft, Auger Drive
6.	714-0126	Key, Hi Pro, 3/16 x 3/4
7.	714-0135	#91 Woodruff Key 1/4 x 3/4
8.	716-0111	Snap Ring .875 Dia.
9.	717-0299	Gear, Worm, Double Thread LH
10.	717-1425	Gear, Worm, LH
11.	721-0145	Seal, Oil .875 ID
12.	721-0325	Plug, 1/4 x .437
13.	736-0266	Washer, Flat, 1.52 x 2.0
14.	736-0291	Washer, Flat, .88 x 1.38
15.	737-3000	Lube Fitting, 3/16 Drive
16.	738-0275	Shaft, Worm Gear
17.	741-0184	Bearing, Thrust .877
18.	741-0217	Sleeve Bearing, .877 x .125 x 1.11
19.	618-0436	Auger Gearbox Assembly Complete

NOTE: When rebuilding a gearbox assembly, include 3 oz. of Shell Alvania EP Lead-Free Grease (Part No. 737-0168).

777D06575



777D06574



777I22052



777I22049



777I22051



777S32065



777S32066



777D06579

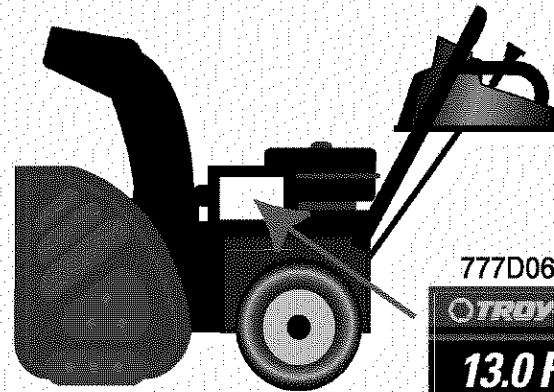
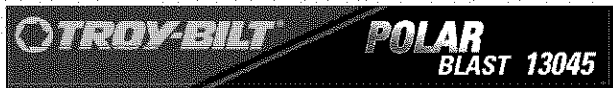

777D06578



MANUFACTURER'S LIMITED WARRANTY FOR:



The limited warranty set forth below is given by Troy-Bilt LLC with respect to new merchandise purchased and used in the United States, its possessions and territories.

Troy-Bilt LLC warrants this product against defects for a period of two (2) years commencing on the date of original purchase and will, at its option, repair or replace, free of charge, any part found to be defective in materials or workmanship. This limited warranty shall only apply if this product has been operated and maintained in accordance with the Operator's Manual furnished with the product, and has not been subject to misuse, abuse, commercial use, neglect, accident, improper maintenance, alteration, vandalism, theft, fire, water, or damage because of other peril or natural disaster. Damage resulting from the installation or use of any accessory or attachment not approved by Troy-Bilt LLC for use with the product(s) covered by this manual will void your warranty as to any resulting damage.

Normal wear parts or components thereof are subject to separate terms as follows: All normal wear parts or component failures will be covered on the product for a period of 90 days regardless of cause. After 90 days, but within the two year period, normal wear part failures will be covered ONLY IF caused by defects in materials or workmanship of OTHER component parts. Normal wear parts and components include, but are not limited to: batteries, belts, blades, blade adapters, grass bags, rider deck wheels, seats, snow thrower skid shoes, shave plates, auger spiral rubber, and tires.

HOW TO OBTAIN SERVICE: Warranty service is available, WITH PROOF OF PURCHASE, through your local authorized service dealer. To locate the dealer in your area, check your Yellow Pages, or contact Troy-Bilt LLC at P.O. Box 361131, Cleveland, Ohio 44136-0019, or call 1-866-840-6483 or 1-330-558-7220, or log on to our Web site at www.troybilt.com.

This limited warranty does not provide coverage in the following cases:

- a. The engine or component parts thereof. These items carry a separate manufacturer's warranty. Refer to applicable manufacturer's warranty for terms and conditions.
- b. Log splitter pumps, valves, and cylinders have a separate one year warranty.
- c. Routine maintenance items such as lubricants, filters, blade sharpening, tune-ups, brake adjustments, clutch adjustments, deck adjustments, and normal deterioration of the exterior finish due to use or exposure.
- d. Troy-Bilt LLC does not extend any warranty for products sold or exported outside of the United States, its possessions and territories, except those sold through Troy-Bilt LLC's authorized channels of export distribution.
- e. Parts that are not genuine Troy-Bilt parts are not covered by this warranty.
- f. Service completed by someone other than an authorized service dealer is not covered by this warranty.
- g. Transportation charges and service calls are not covered.

No implied warranty, including any implied warranty of merchantability of fitness for a particular purpose, applies after the applicable period of express written warranty above as to the parts as identified. No other express warranty, whether written or oral, except as mentioned above, given by any person or entity, including a dealer or retailer, with respect to any product, shall bind Troy-Bilt LLC. During the period of the warranty, the exclusive remedy is repair or replacement of the product as set forth above.

The provisions as set forth in this warranty provide the sole and exclusive remedy arising from the sale. Troy-Bilt LLC shall not be liable for incidental or consequential loss or damage including, without limitation, expenses incurred for substitute or replacement lawn care services or for rental expenses to temporarily replace a warranted product.

Some states do not allow the exclusion or limitation of incidental or consequential damages, or limitations on how long an implied warranty lasts, so the above exclusions or limitations may not apply to you.

In no event shall recovery of any kind be greater than the amount of the purchase price of the product sold. **Alteration of safety features of the product shall void this warranty.** You assume the risk and liability for loss, damage, or injury to you and your property and/or to others and their property arising out of the misuse or inability to use the product.

This limited warranty shall not extend to anyone other than the original purchaser or to the person for whom it was purchased as a gift.

HOW STATE LAW RELATES TO THIS WARRANTY: This limited warranty gives you specific legal rights, and you may also have other rights which vary from state to state.

Troy-Bilt LLC, P.O. BOX 361131 CLEVELAND, OHIO 44136-0019; Phone: 1-866-840-6483, 1-330-558-7220