

YTH2148

Owner's Manual

For Parts and Service, call 1-800-448-7543

SAFETY RULES



Safe Operation Practices for Ride-On Mowers



IMPORTANT: THIS CUTTING MACHINE IS CAPABLE OF AMPUTATING HANDS AND FEET AND THROWING OBJECTS. FAILURE TO OBSERVE THE FOLLOWING SAFETY INSTRUCTIONS COULD RESULT IN SERIOUS INJURY OR DEATH.

I. GENERAL OPERATION

- Read, understand, and follow all instructions in the manual and on the machine before starting.
- Only allow responsible adults, who are familiar with the instructions, to operate the machine.
- Clear the area of objects such as rocks, toys, wire, etc., which could be picked up and thrown by the blade.
- Be sure the area is clear of other people before mowing. Stop machine if anyone enters the area.
- Never carry passengers.
- Do not mow in reverse unless absolutely necessary. Always look down and behind before and while backing.
- Be aware of the mower discharge direction and do not point it at anyone. Do not operate the mower without either the entire grass catcher or the guard in place.
- Slow down before turning.
- Never leave a running machine unattended. Always turn off blades, set parking brake, stop engine, and remove keys before dismounting.
- Turn off blades when not mowing.
- Stop engine before removing grass catcher or unclogging chute.
- Mow only in daylight or good artificial light.
- Do not operate the machine while under the influence of alcohol or drugs.
- Watch for traffic when operating near or crossing roadways.
- Use extra care when loading or unloading the machine into a trailer or truck.
- Data indicates that operators, age 60 years and above, are involved in a large percentage of riding mower-related injuries. These operators should evaluate their ability to operate the riding mower safely enough to protect themselves and others from serious injury.
- Keep machine free of grass, leaves or other debris build-up which can touch hot exhaust / engine parts and burn. Do not allow the mower deck to plow leaves or other debris which can cause build-up to occur. Clean any oil or fuel spillage before operating or storing the machine. Allow machine to cool before storage.

II. SLOPE OPERATION

Slopes are a major factor related to loss-of-control and tipover accidents, which can result in severe injury or death. All slopes require extra caution. If you cannot back up the slope or if you feel uneasy on it, do not mow it.

DO:

- Mow up and down slopes, not across.
- Remove obstacles such as rocks, tree limbs, etc.
- Watch for holes, ruts, or bumps. Uneven terrain could overturn the machine. *Tall grass can hide obstacles.*
- Use slow speed. Choose a low gear so that you will not have to stop or shift while on the slope.
- Follow the manufacturer's recommendations for wheel weights or counterweights to improve stability.
- Use extra care with grass catchers or other attachments. These can change the stability of the machine.
- Keep all movement on the slopes *slow* and *gradual*. Do not make sudden changes in speed or direction.

- Avoid starting or stopping on a slope. If tires lose traction, disengage the blades and proceed slowly *straight* down the slope.

DO NOT:

- *Do not* turn on slopes unless necessary, and then, turn slowly and gradually downhill, if possible.
- *Do not* mow near drop-offs, ditches, or embankments. The mower could suddenly turn over if a wheel is over the edge of a cliff or ditch, or if an edge caves in.
- *Do not* mow on wet grass. Reduced traction could cause sliding.
- *Do not* try to stabilize the machine by putting your foot on the ground.
- *Do not* use grass catcher on steep slopes.

III. CHILDREN

Tragic accidents can occur if the operator is not alert to the presence of children. Children are often attracted to the machine and the mowing activity. *Never* assume that children will remain where you last saw them.

- Keep children out of the mowing area and under the watchful care of another responsible adult.
- Be alert and turn machine off if children enter the area.
- Before and when backing, look behind and *down* for small children.
- Never carry children. They may fall off and be seriously injured or interfere with safe machine operation.
- Never allow children to operate the machine.
- Use extra care when approaching blind corners, shrubs, trees, or other objects that may obscure vision.

IV. SERVICE

- Use extra care in handling gasoline and other fuels. They are flammable and vapors are explosive.
 - Use only an approved container.
 - Never remove gas cap or add fuel with the engine running. Allow engine to cool before refueling. Do not smoke.
 - Never refuel the machine indoors.
 - Never store the machine or fuel container inside where there is an open flame, such as a water heater.
- Never run a machine inside a closed area.
- Keep nuts and bolts, especially blade attachment bolts, tight and keep equipment in good condition.
- Never tamper with safety devices. Check their proper operation regularly.
- Keep machine free of grass, leaves, or other debris build-up. Clean oil or fuel spillage. Allow machine to cool before storing.
- Stop and inspect the equipment if you strike an object. Repair, if necessary, before restarting.
- Never make adjustments or repairs with the engine running.
- Grass catcher components are subject to wear, damage, and deterioration, which could expose moving parts or allow objects to be thrown. Frequently check components and replace with manufacturer's recommended parts, when necessary.
- Mower blades are sharp and can cut. Wrap the blade(s) or wear gloves, and use extra caution when servicing them.
- Check brake operation frequently. Adjust and service as required.

SAFETY RULES



Safe Operation Practices for Ride-On Mowers

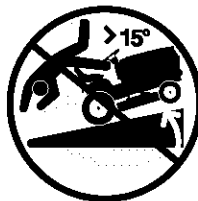

- Be sure the area is clear of other people before mowing. Stop machine if anyone enters the area.
- Never carry passengers or children even with the blades off.
- Do not mow in reverse unless absolutely necessary. Always look down and behind before and while backing.
- Never carry children. They may fall off and be seriously injured or interfere with safe machine operation.
- Keep children out of the mowing area and under the watchful care of another responsible adult.
- Be alert and turn machine off if children enter the area.
- Before and when backing, look behind and down for small children.
- Mow up and down slopes (15° Max), not across.
- Remove obstacles such as rocks, tree limbs, etc.
- Watch for holes, ruts, or bumps. Uneven terrain could overturn the machine. Tall grass can hide obstacles.
- Use slow speed. Choose a low gear so that you will not have to stop or shift while on the slope.
- Avoid starting or stopping on a slope. If tires lose traction, disengage the blades and proceed slowly straight down the slope.
- If machine stops while going uphill, disengage blades, shift into reverse and back down slowly.
- Do not turn on slopes unless necessary, and then, turn slowly and gradually downhill, if possible.



WARNING: In order to prevent accidental starting when setting up, transporting, adjusting or making repairs, always disconnect spark plug wire and place wire where it cannot contact spark plug.



WARNING: Do not coast down a hill in neutral, you may lose control of the tractor.



WARNING: Tow only the attachments that are recommended by and comply with specifications of the manufacturer of your tractor. Use common sense when towing. Operate only at the lowest possible speed when on a slope. Too heavy of a load, while on a slope, is dangerous. Tires can lose traction with the ground and cause you to lose control of your tractor.



WARNING



Engine exhaust, some of its constituents, and certain vehicle components contain or emit chemicals known to the State of California to cause cancer and birth defects or other reproductive harm.



WARNING



Battery posts, terminals and related accessories contain lead and lead compounds, chemicals known to the State of California to cause cancer and birth defects or other reproductive harm. Wash hands after handling.

PRODUCT SPECIFICATIONS

| | | |
|-----------------------------|---|-----------|
| Gasoline Capacity and type: | 4 Gallons Unleaded Regular | |
| Oil Type (API-SF-SJ): | SAE 30 (above 32°F) SAE 5W-30 (below 32°F) | |
| Oil Capacity: | W/ Filter: | 3.5 Pints |
| | W/O Filter: | 3.0 Pints |
| Spark Plug: (Gap: .040") | Champion RC12YC | |
| Ground Speed (MPH): | Forward: | 0 – 5.5 |
| | Reverse: | 0 – 2.4 |
| Tire Pressure: | Front: | 14 PSI |
| | Rear: | 10 PSI |
| Charging System: | 16 AMPS @ 3600 RPM | |
| Battery: | AMP/HR: | 35 |
| | MIN. CCA: | 280 |
| | Case Size: | U1R |
| Blade Bolt Torque: | 45-55FT. LBS. | |

CONGRATULATIONS on your purchase of a new tractor. It has been designed, engineered and manufactured to give you the best possible dependability and performance.

Should you experience any problem you cannot easily remedy, please contact your nearest authorized servicecenter/department. We have competent, well-trained technicians and the proper tools to service or repair this tractor.

Please read and retain this manual. The instructions will enable you to assemble and maintain your tractor properly. Always observe the "SAFETY RULES".

CUSTOMER RESPONSIBILITIES

- Read and observe the safety rules.
- Follow a regular schedule in maintaining, caring for and using your tractor.
- Follow the instructions under "Maintenance" and "Storage" sections of this owner's manual.

WARNING: This tractor is equipped with an internal combustion engine and should not be used on or near any unimproved forest-covered, brush-covered or grass-covered land unless the engine's exhaust system is equipped with a spark arrester meeting applicable local or state laws (if any). If a spark arrester is used, it should be maintained in effective working order by the operator.

In the state of California the above is required by law (Section 4442 of the California Public Resources Code). Other states may have similar laws. Federal laws apply on federal lands.

A spark arrester for the muffler is available through your nearest authorized service center/department (See REPAIR PARTS section of this manual).

TABLE OF CONTENTS

| | |
|---------------------------------|-------|
| SAFETY RULES | 2-3 |
| PRODUCT SPECIFICATIONS | 4 |
| CUSTOMER RESPONSIBILITIES | 4 |
| ASSEMBLY | 6-9 |
| OPERATION | 10-15 |
| MAINTENANCE SCHEDULE | 16 |

| | |
|-------------------------------|-------|
| MAINTENANCE | 16-19 |
| SERVICE AND ADJUSTMENTS | 20-25 |
| STORAGE | 26 |
| TROUBLESHOOTING | 27-28 |
| REPAIR PARTS - TRACTOR | 30-45 |

UNASSEMBLED PARTS

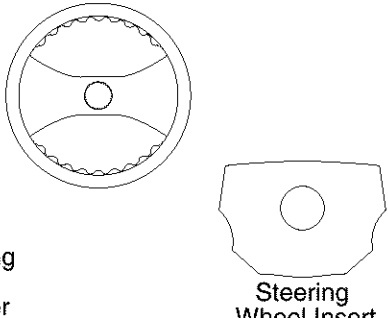
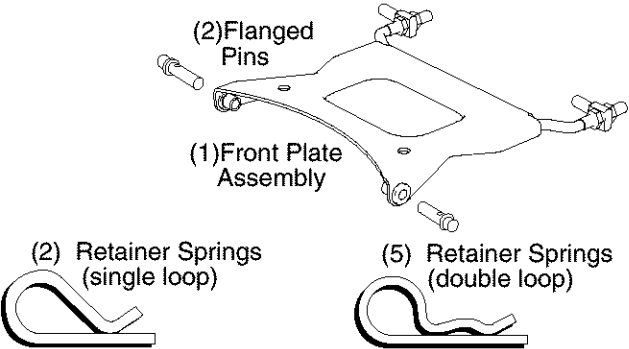
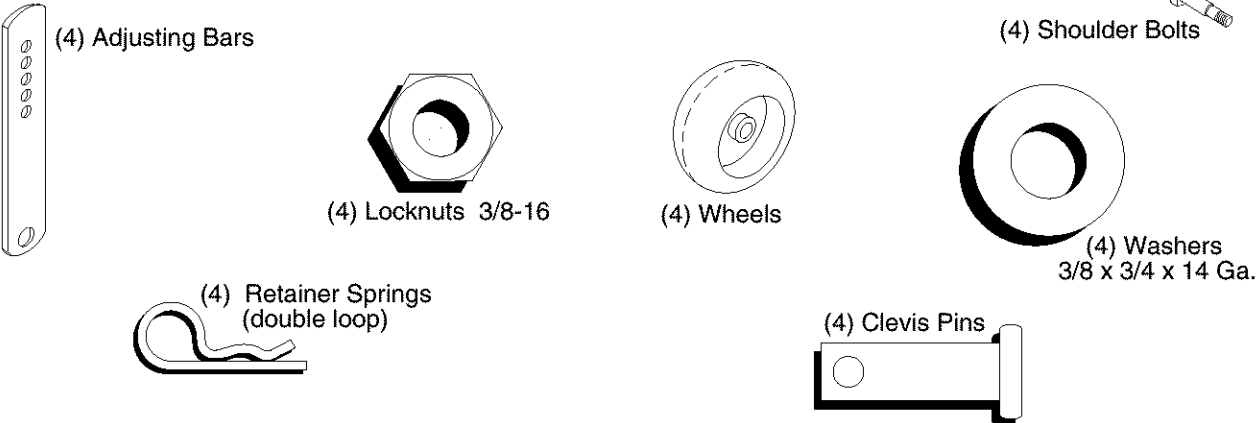
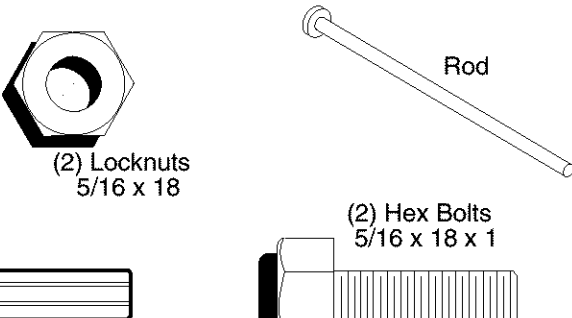
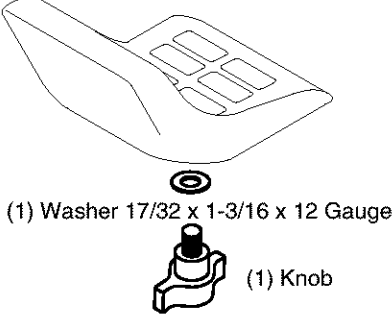
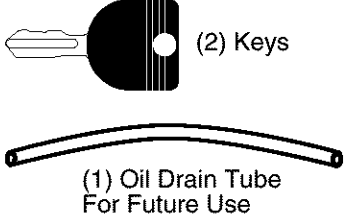
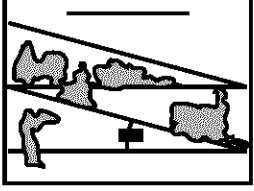
| | |
|--|--|
| <p style="text-align: center;">Steering Wheel</p>  <p>Steering Wheel Adapter</p> <p>Steering Wheel Insert</p> | <p style="text-align: center;">Mower</p>  <p>(2) Flanged Pins</p> <p>(1) Front Plate Assembly</p> <p>(2) Retainer Springs (single loop)</p> <p>(5) Retainer Springs (double loop)</p> |
| <p style="text-align: center;">Gauge Wheels</p>  <p>(4) Adjusting Bars</p> <p>(4) Locknuts 3/8-16</p> <p>(4) Wheels</p> <p>(4) Retainer Springs (double loop)</p> <p>(4) Clevis Pins</p> <p>(4) Shoulder Bolts</p> <p>(4) Washers 3/8 x 3/4 x 14 Ga.</p> | |
| <p style="text-align: center;">Nose Roller</p>  <p>(2) Locknuts 5/16 x 18</p> <p>Rod</p> <p>(2) Hex Bolts 5/16 x 18 x 1</p> <p>Nose Roller</p> <p>Nose Roller Brackets</p> | <p style="text-align: center;">Seat</p>  <p>(1) Washer 17/32 x 1-3/16 x 12 Gauge</p> <p>(1) Knob</p> |
| <p style="text-align: center;">Keys</p>  <p>(2) Keys</p> <p>(1) Oil Drain Tube For Future Use</p> | <p style="text-align: center;">Slope Sheet</p>  |

ASSEMBLY

Your new tractor has been assembled at the factory with exception of those parts left unassembled for shipping purposes. To ensure safe and proper operation of your tractor all parts and hardware you assemble must be tightened securely. Use the correct tools as necessary to insure proper tightness.

TOOLS REQUIRED FOR ASSEMBLY

A socket wrench set will make assembly easier. Standard wrench sizes are listed.

- (1) Tire pressure gauge
- (2) 3/4" wrenches
- (2) 7/16" wrenches
- (1) Pliers
- (1) Utility knife
- (1) 3/4" socket w/drive ratchet

When right or left hand is mentioned in this manual, it means when you are in the operating position (seated behind the steering wheel).

TO REMOVE TRACTOR FROM CARTON

UNPACK CARTON

- Remove all accessible loose parts and parts cartons from carton .
- Cut along dotted lines on all four panels of carton. Remove end panels and lay side panels flat.
- Remove mower and packing materials.
- Check for any additional loose parts or cartons and remove.

BEFORE REMOVING TRACTOR FROM SKID

ATTACH STEERING WHEEL (See Fig. 1)

- Remove locknut and large flat washer from steering shaft.
- Position front wheels of the tractor so they are pointing straight forward.
- Position steering wheel so cross bars are horizontal (left to right) and slide onto steering wheel adapter.
- Secure steering wheel to steering shaft with locknut and large flat washer previously removed. Tighten securely.
- Snap steering wheel insert into center of steering wheel.
- Remove protective materials from tractor hood and grill.

IMPORTANT: CHECK FOR AND REMOVE ANY STAPLES IN SKID THAT MAY PUNCTURE TIRES WHERE TRACTOR IS TO ROLL OFF SKID.

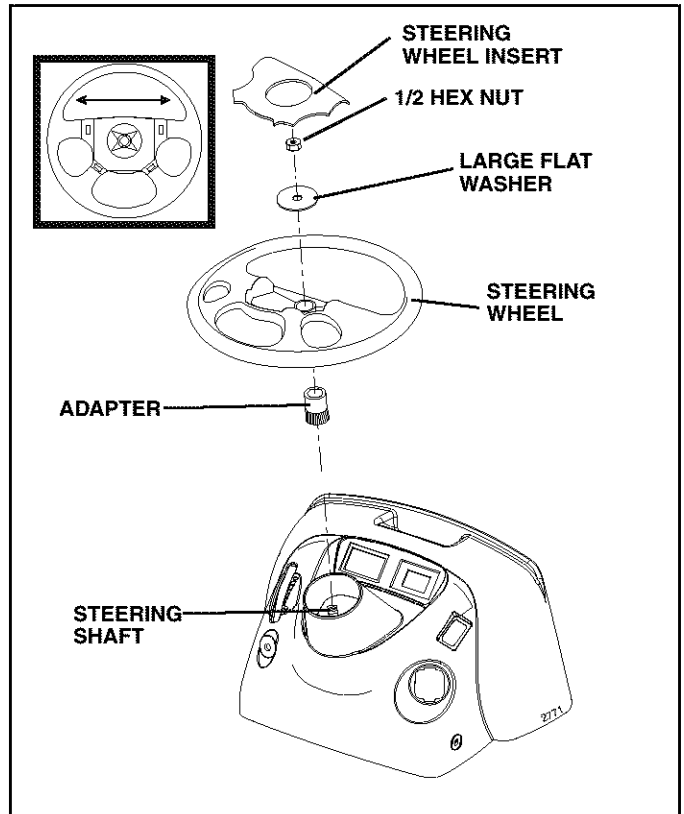

FIG. 1

HOW TO SET UP YOUR TRACTOR

CHECK BATTERY (See Fig. 2)

- Lift hood to raised position.
- If this battery is put into service after month and year indicated on label (label located between terminals) charge battery for minimum of one hour at 6-10 amps. (See "BATTERY" in Maintenance section of this manual for charging instructions).

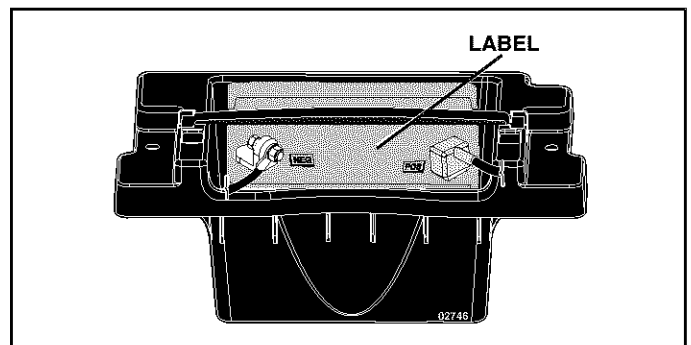

FIG. 2

ASSEMBLY

INSTALL SEAT (See Fig. 3)

Adjust seat before tightening adjustment knob.

- Remove adjustment knob and flat washer securing seat to cardboard packing and set aside for assembly of seat to tractor.
- Pivot seat upward and remove from the cardboard packing. Remove the cardboard packing and discard.
- Place seat on seat pan so head of shoulder bolt is positioned over large slotted hole in pan.
- Push down on seat to engage shoulder bolt in slot and pull seat towards rear of tractor.
- Pivot seat and pan forward and assemble adjustment knob and flat washer loosely. Do not tighten.
- Lower seat into operating position and sit on seat.
- Slide seat until a comfortable position is reached which allows you to press clutch/brake pedal all the way down.
- Get off seat without moving its adjusted position.
- Raise seat and tighten adjustment knob securely.

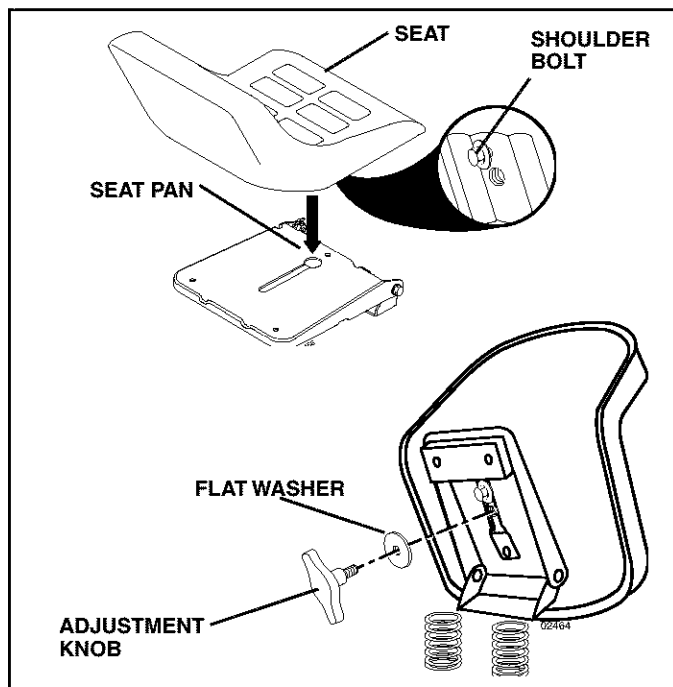

FIG. 3

NOTE: You may now roll or drive your tractor off the skid. Follow the appropriate instruction below to remove the tractor from the skid.

TO ROLL TRACTOR OFF SKID (See Operation section for location and function of controls)

- Press lift lever plunger and raise attachment lift lever to its highest position.
- Release parking brake by depressing clutch/brake pedal.
- Place freewheel control in "transmission disengaged position" (See "TO TRANSPORT" in the Operation section of this manual).
- Roll tractor forward off skid.

TO DRIVE TRACTOR OFF SKID (See Operation section for location and function of controls)

WARNING: Before starting, read, understand and follow all instructions in the Operation section of this manual. Be sure tractor is in a well-ventilated area. Be sure the area in front of tractor is clear of other people and objects.

- Be sure all the above assembly steps have been completed.
- Check engine oil level and fill fuel tank with gasoline.
- Place freewheel control in "transmission engaged" position (see "TO TRANSPORT" in Operation section of this manual).
- Sit on seat in operating position, depress clutch/brake pedal and set the parking brake.
- Place motion control lever in neutral (N) position.
- Press lift lever plunger and raise attachment lift lever to its highest position.
- Start the engine. After engine has started, move throttle control to idle position.
- Release parking brake.
- Slowly move the motion control lever forward and slowly drive tractor off skid.
- Apply brake to stop tractor, set parking brake and place motion control lever in neutral position.
- Turn ignition key to "STOP" position.

Continue with the instructions that follow.

TO ATTACH NOSE ROLLER (See Fig. 4)

- Assemble brackets "A" and "B" to the inside of mower mounting brackets as shown. Tighten securely.

NOTE: Be sure bracket tabs are positioned in tab holes in mower brackets.

- Position nose roller between brackets and install rod and retainer spring.

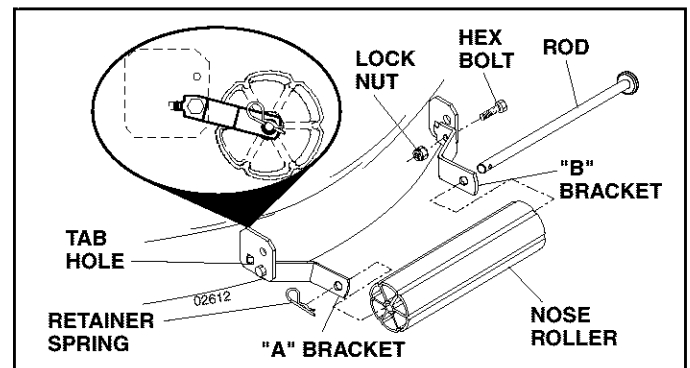

FIG. 4

ASSEMBLE GAUGE WHEELS TO MOWER DECK (See Fig. 5)

The gauge wheels are designed to keep the mower deck in proper position when operating mower. Be sure they are properly adjusted to ensure optimum mower performance.

- Slide gauge wheel bar down into bracket channel. Be sure that gauge wheel bar aligning holes are on top. Assemble gauge wheels as shown using shoulder bolts, 3/8 washers and 3/8-16 center locknuts and tighten securely.

ASSEMBLY

- For ease of mower to tractor assembly, raise gauge wheels to highest position and retain with clevis pins and spring retainers.
- Adjust gauge wheels before operating mower. See "TO ADJUST GAUGE WHEELS" in the Operation section of this manual.

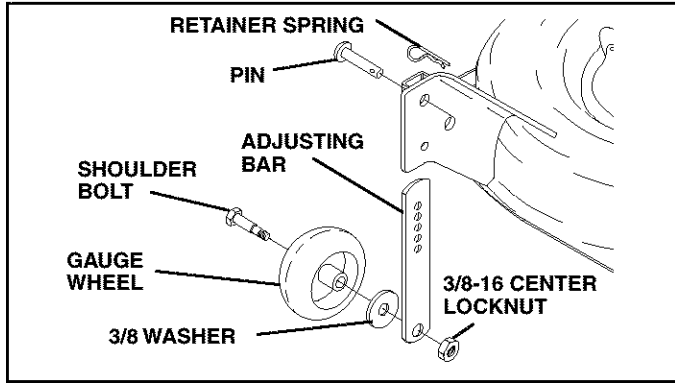

FIG. 5

INSTALL MOWER AND DRIVE BELT (See Figs. 6 and 7)

Be sure tractor is on level surface and mower suspension arms are raised with attachment lift control. Engage parking brake.

- Cut and remove ties securing anti-sway bar and belts. Swing anti-sway bar to left side of mower deck.
- Slide mower under tractor with deflector shield to right side of tractor.

IMPORTANT: Check belt for proper routing in all mower pulley grooves.

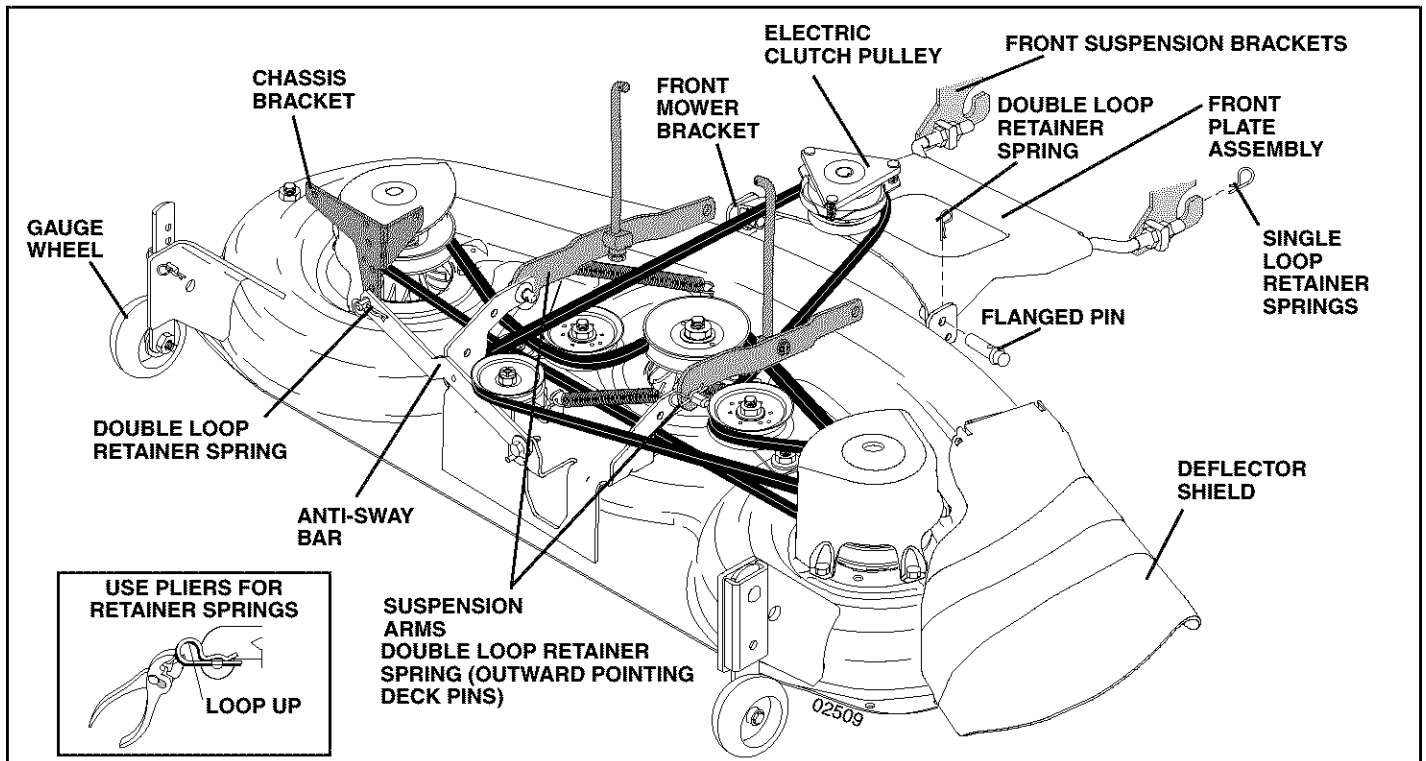

FIG. 6

- If equipped, turn height adjustment knob counter-clockwise until it stops.
- Lower mower linkage with attachment lift control.
- Install belt into electric clutch pulley groove.
- Place the suspension arms on outward pointing deck pins. Retain with double loop retainer spring with loops up as shown.
- Install front plate assembly to tractor suspension brackets and retain with single loop retainer springs as shown.
- Position front plate assembly between front mower brackets. Raise deck and plate assembly to align holes and insert flanged pins. Secure pins with double loop retainer springs between the plate and mower brackets.

NOTE: To assist in locating hole in flanged pin, the hole in pin is inline with notch on head of pin. If necessary, move mower side-to-side to give space between plate and mower brackets.

IMPORTANT: Check belt for proper routing in all mower pulley grooves.

- Connect anti-sway bar to chassis bracket under left footrest and retain with double loop retainer spring.
- If equipped, turn height adjustment knob clockwise to remove slack from mower suspension.
- Raise deck to highest position.
- Adjust gauge wheels before operating mower as shown in the Operation section of this manual.

ASSEMBLY

CHECK TIRE PRESSURE

The tires on your tractor were overinflated at the factory for shipping purposes. Correct tire pressure is important for best cutting performance.

- Reduce tire pressure to PSI shown in "PRODUCT SPECIFICATIONS" section of this manual.

CHECK MOWER LEVELNESS

For best cutting results, mower should be properly leveled. See "TO LEVEL MOWER HOUSING" in the Service and Adjustments section of this manual.

CHECK FOR PROPER POSITION OF ALL BELTS

See the figures that are shown for replacing motion, mower drive, and mower blade drive belts in the Service and Adjustments section of this manual. Verify that the belts are routed correctly.

CHECK BRAKE SYSTEM

After you learn how to operate your tractor, check to see that the brake is properly adjusted. See "TO ADJUST BRAKE" in the Service and Adjustments section of this manual.

✓ CHECKLIST

BEFORE YOU OPERATE AND ENJOY YOUR NEW TRACTOR, WE WISH TO ASSURE THAT YOU RECEIVE THE BEST PERFORMANCE AND SATISFACTION FROM THIS QUALITY PRODUCT.

PLEASE REVIEW THE FOLLOWING CHECKLIST:

- ✓ All assembly instructions have been completed.
- ✓ No remaining loose parts in carton.
- ✓ Battery is properly prepared and charged. (Minimum 1 hour at 6 amps).
- ✓ Seat is adjusted comfortably and tightened securely.
- ✓ All tires are properly inflated. (For shipping purposes, the tires were overinflated at the factory).
- ✓ Be sure mower deck is properly leveled side-to-side/ front-to-rear for best cutting results. (Tires must be properly inflated for leveling).
- ✓ Check mower and drive belts. Be sure they are routed properly around pulleys and inside all belt keepers.
- ✓ Check wiring. See that all connections are still secure and wires are properly clamped.
- ✓ Before driving tractor, be sure freewheel control is in drive position.

WHILE LEARNING HOW TO USE YOUR TRACTOR, PAY EXTRA ATTENTION TO THE FOLLOWING IMPORTANT ITEMS:

- ✓ Engine oil is at proper level.
- ✓ Fuel tank is filled with fresh, clean, regular unleaded gasoline.
- ✓ Become familiar with all controls - their location and function. Operate them before you start the engine.
- ✓ Be sure brake system is in safe operating condition.
- ✓ It is important to purge the transmission before operating your tractor for the first time. Follow proper starting and transmission purging instructions (See "TO START ENGINE" and "PURGE TRANSMISSION" in the Operation section of this manual).

OPERATION

These symbols may appear on your tractor or in literature supplied with the product. Learn and understand their meaning.

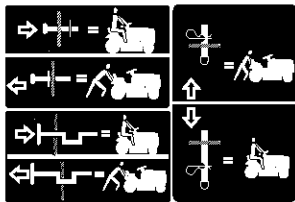
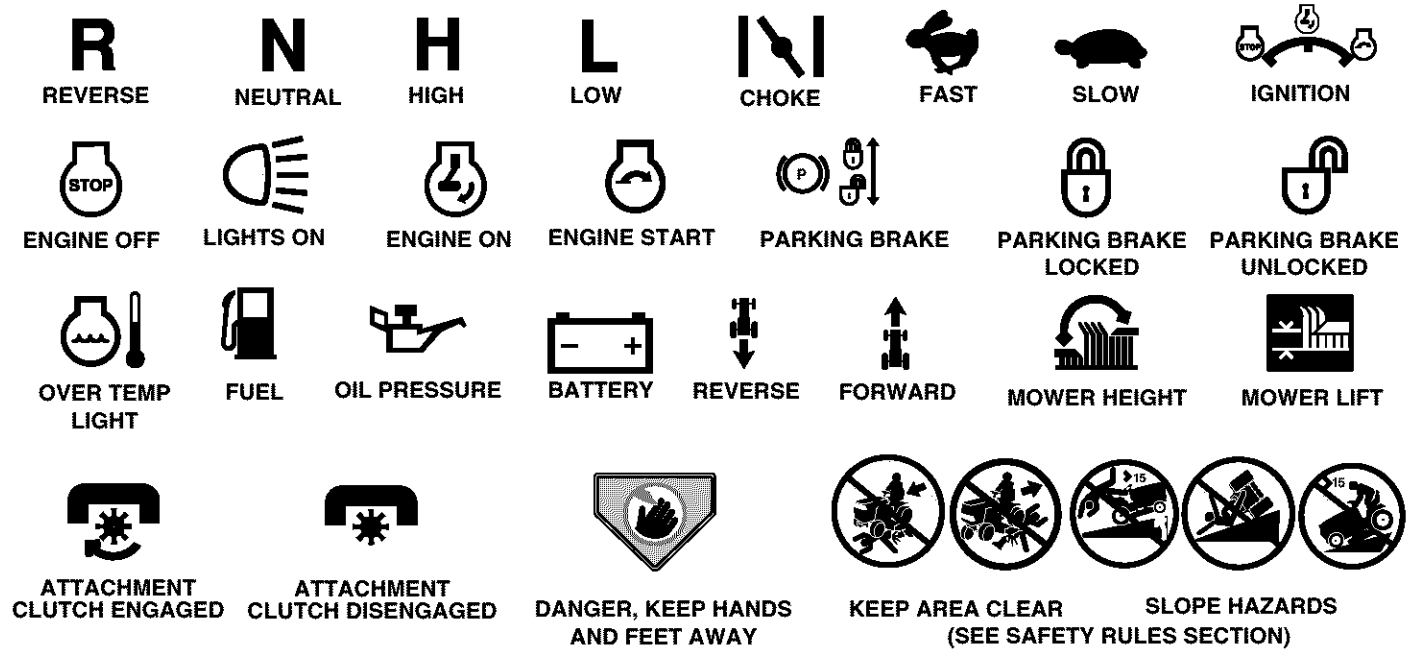

FREE WHEEL
(Automatic Models only)



Failure to follow instructions could result in serious injury or death. The safety alert symbol is used to identify safety information about hazards which can result in death, serious injury and/or property damage.



DANGER indicates a hazard which, if not avoided, will result in death or serious injury.



WARNING indicates a hazard which, if not avoided, could result in death or serious injury.



CAUTION indicates a hazard which, if not avoided, might result in minor or moderate injury.

CAUTION when used **without** the alert symbol, indicates a situation that **could result in damage to the tractor and/or engine.**



HOT SURFACES indicates a hazard which, if not avoided, could result in death, serious injury and/or property damage.



FIRE indicates a hazard which, if not avoided, could result in death, serious injury and/or property damage.

OPERATION

KNOW YOUR TRACTOR

READ THIS OWNER'S MANUAL AND SAFETY RULES BEFORE OPERATING YOUR TRACTOR

Compare the illustrations with your tractor to familiarize yourself with the locations of various controls and adjustments. Save this manual for future reference.

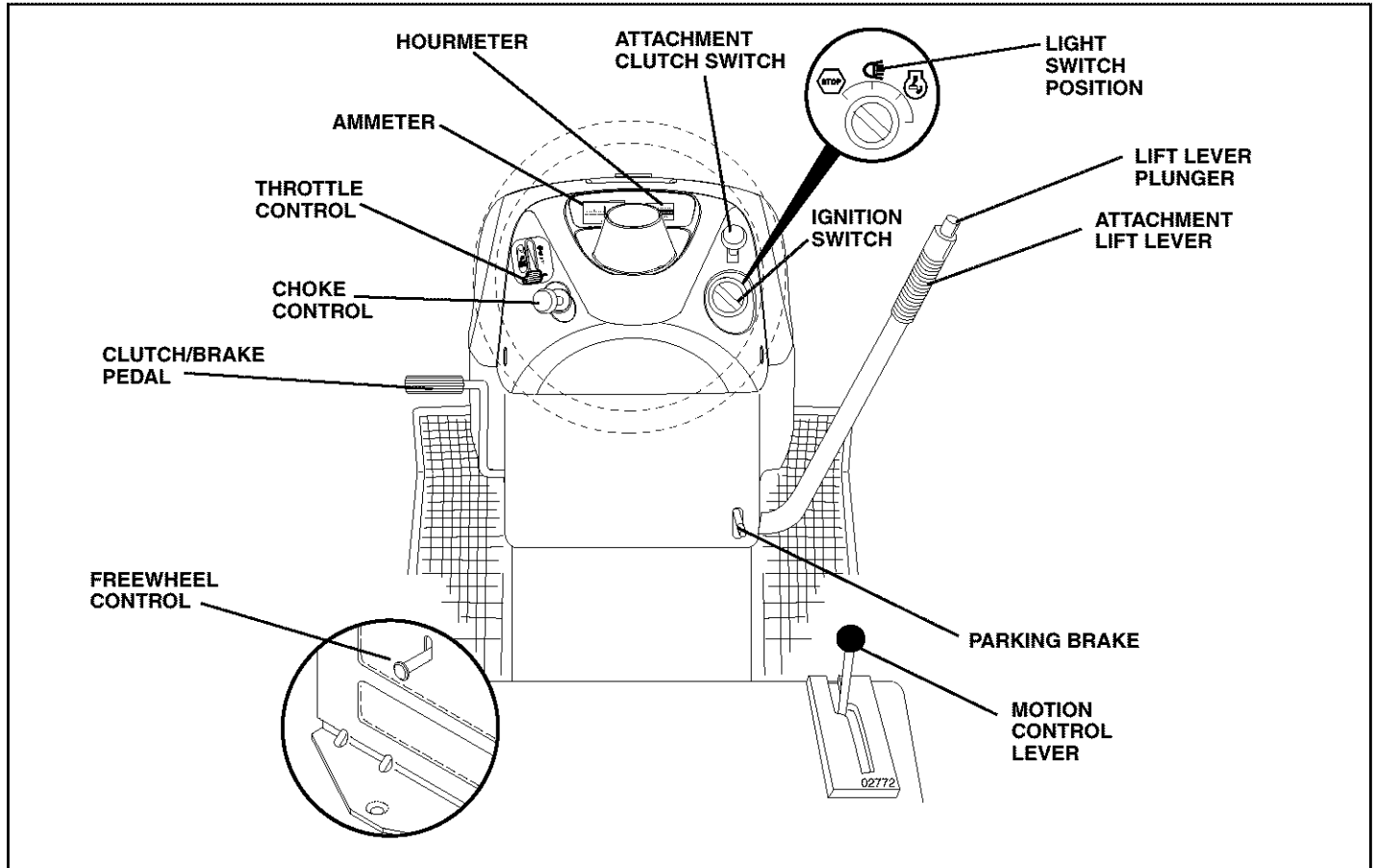

FIG. 7

Our tractors conform to the safety standards of the American National Standards Institute.

ATTACHMENT CLUTCH SWITCH - Used to engage the mower blades, or other attachments mounted to your tractor.

LIGHT SWITCH POSITION - Turns the headlights on.

THROTTLE CONTROL - Used to control engine speed.

CHOKE CONTROL - Used when starting a cold engine.

FREE WHEEL CONTROL - Disengages transmission for pushing or slowly towing the tractor with the engine off.

CLUTCH/BRAKE PEDAL - Used for declutching and braking the tractor and starting the engine.

HOURMETER- Indicates hours of operation.

AMMETER - Indicates charging (+) or discharging (-) of battery.

PARKING BRAKE - Locks clutch/brake pedal into the brake position.

MOTION CONTROL LEVER - Selects the speed and direction of tractor.

ATTACHMENT LIFT LEVER - Used to raise, lower and adjust the mower deck or other attachments mounted to your tractor.

LIFT LEVER PLUNGER - Used to release attachment lift lever when changing its position.

IGNITION SWITCH - Used for starting and stopping the engine.

OPERATION



The operation of any tractor can result in foreign objects thrown into the eyes, which can result in severe eye damage. Always wear safety glasses or eye shields while operating your tractor or performing any adjustments or repairs. We recommend a wide vision safety mask over spectacles or standard safety glasses.

HOW TO USE YOUR TRACTOR

TO SET PARKING BRAKE (See Fig. 8)

Your tractor is equipped with an operator presence sensing switch. When engine is running, any attempt by the operator to leave the seat without first setting the parking brake will shut off the engine.

- Depress clutch/brake pedal into full "BRAKE" position and hold.
- Place parking brake lever in "ENGAGED" position and release pressure from clutch/brake pedal. Pedal should remain in "BRAKE" position. Make sure parking brake will hold tractor secure.

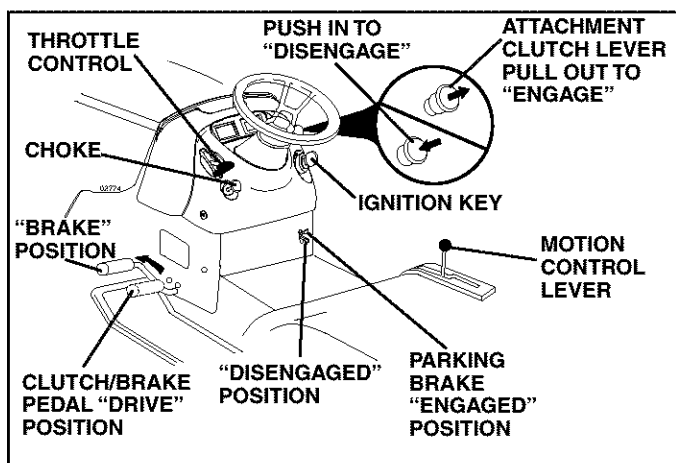

FIG. 8

STOPPING (See Fig. 8)

MOWER BLADES -

- To stop mower blades, move attachment clutch switch to "DISENGAGED" position.

GROUND DRIVE -

- To stop ground drive, depress clutch/brake pedal into full "BRAKE" position..
- Move motion control lever to neutral (N) position.

IMPORTANT: THE MOTION CONTROL LEVER DOES NOT RETURN TO NEUTRAL (N) POSITION WHEN THE CLUTCH/BRAKE PEDAL IS DEPRESSED.

ENGINE -

- Move throttle control to slow position.

NOTE: Failure to move throttle control to slow position and allowing engine to idle before stopping may cause engine to "backfire".

- Turn ignition key to "OFF" position and remove key. Always remove key when leaving tractor to prevent unauthorized use.

- Never use choke to stop engine.

IMPORTANT: LEAVING THE IGNITION SWITCH IN ANY POSITION OTHER THAN "OFF" WILL CAUSE THE BATTERY TO BE DISCHARGED, (DEAD).

NOTE: Under certain conditions when tractor is standing idle with the engine running, hot engine exhaust gases may cause "browning" of grass. To eliminate this possibility, always stop engine when stopping tractor on grass areas.



CAUTION: Always stop tractor completely, as described above, before leaving the operator's position; to empty grass catcher, etc.

TO USE THROTTLE CONTROL (See Fig. 8)

Always operate engine at full throttle.

- Operating engine at less than full throttle reduces the battery charging rate.
- Full throttle offers the best bagging and mower performance.

TO USE CHOKE CONTROL (See Fig. 8)

Use choke control whenever you are starting a cold engine. Do not use to start a warm engine.

- To engage choke control, pull knob out. Slowly push knob in to disengage.

TO MOVE FORWARD AND BACKWARD (See Fig. 8)

The direction and speed of movement is controlled by the motion control lever.

- Start tractor with motion control lever in neutral (N) position.
- Release parking brake.
- Slowly move motion control lever to desired position.

TO ADJUST MOWER CUTTING HEIGHT (See Fig. 8)

The position of the attachment lift lever determines the cutting height.

- Grasp lift lever.
- Press plunger with thumb and move lever to desired position.

The cutting height range is approximately 1-1/2 to 4". The heights are measured from the ground to the blade tip with the engine not running. These heights are approximate and may vary depending upon soil conditions, height of grass and types of grass being mowed.

- The average lawn should be cut to approximately 2-1/2 inches during the cool season and to over 3 inches during hot months. For healthier and better looking lawns, mow often and after moderate growth.
- For best cutting performance, grass over 6 inches in height should be mowed twice. Make the first cut relatively high; the second to desired height.

OPERATION

TO ADJUST GAUGE WHEELS (See Fig. 9)

Gauge wheels are properly adjusted when they are slightly off the ground when mower is at the desired cutting height in operating position. Gauge wheels then keep the deck in proper position to help prevent scalping in most terrain conditions.

NOTE: Adjust gauge wheels with tractor on a flat level surface.

- Adjust mower to desired cutting height (See "TO ADJUST MOWER CUTTING HEIGHT" in the Operation section of this manual).
- Remove retainer spring and clevis pin which secure each gauge wheel bar.
- Lower gauge wheels to ground. Raise gauge wheels slightly to align holes in bracket and gauge wheel bar and insert clevis pin. Gauge wheels should be slightly off the ground.
- Replace retainer spring into clevis pin.
- Be sure all gauge wheels are in the same setting.

IMPORTANT: BE SURE TO READJUST GAUGE WHEELS IF YOU CHANGE THE CUTTING HEIGHT OF THE MOWER DECK.

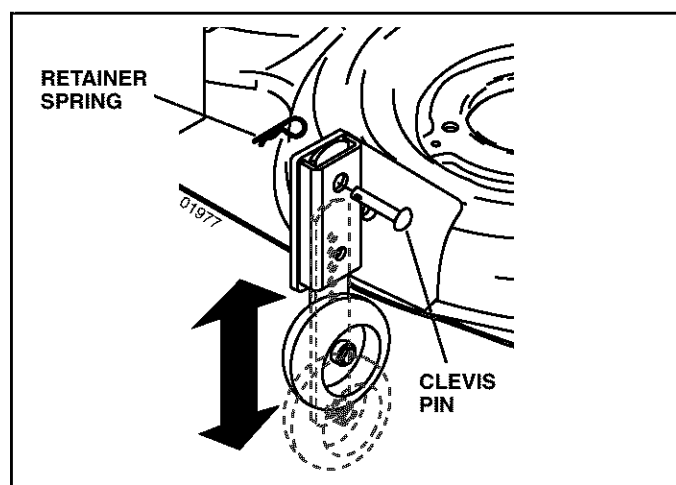

FIG. 9

TO OPERATE MOWER (See Fig. 10)

Your tractor is equipped with an operator presence sensing switch. Any attempt by the operator to leave the seat with the engine running and the attachment clutch engaged will shut off the engine. You must remain fully and centrally positioned in the seat to prevent the engine from hesitating or cutting off when operating your equipment on rough, rolling terrain or hills.

- Select desired height of cut.
- Start mower blades by engaging attachment clutch control.
- TO STOP MOWER BLADES - disengage attachment clutch control.



CAUTION: Do not operate the mower without either the entire grass catcher, on mowers so equipped, or the deflector shield in place.

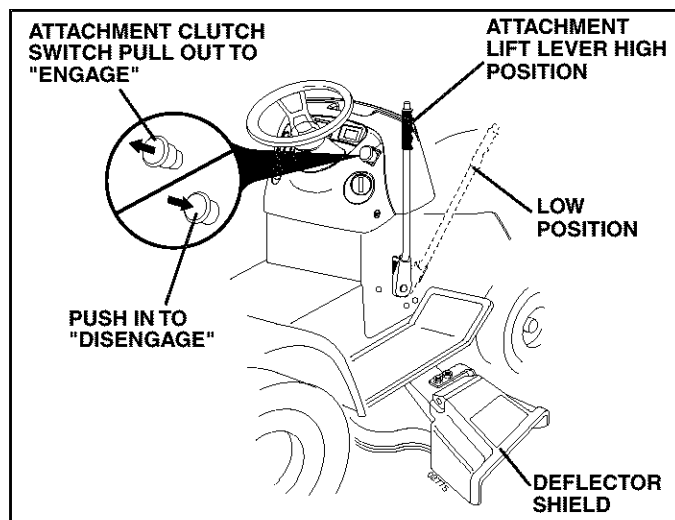

FIG. 10

TO OPERATE ON HILLS



WARNING: Do not drive up or down hills with slopes greater than 15° and do not drive across any slope.

- Choose the slowest speed before starting up or down hills.
- Avoid stopping or changing speed on hills.
- If slowing is necessary, move throttle control lever to slower position.
- If stopping is absolutely necessary, push clutch/brake pedal quickly to brake position and engage parking brake.
- Move motion control lever to neutral (N) position.

IMPORTANT: THE MOTION CONTROL LEVER DOES NOT RETURN TO NEUTRAL (N) POSITION WHEN THE CLUTCH/ BRAKE PEDAL IS DEPRESSED.

- To restart movement, slowly release parking brake and clutch/brake pedal.
- Slowly move motion control lever to slowest setting.
- Make all turns slowly.

TO TRANSPORT (See Figs. 7 and 11)

When pushing or towing your tractor, be sure to disengage transmission by placing freewheel control in freewheeling position. Free wheel control is located at the rear drawbar of tractor.

- Raise attachment lift to highest position with attachment lift control.
- Pull freewheel control out and down into the slot and release so it is held in the disengaged position.
- Do not push or tow tractor at more than two (2) MPH.
- To reengage transmission, reverse above procedure.

NOTE: To protect hood from damage when transporting your tractor on a truck or a trailer, be sure hood is closed and secured to tractor. Use an appropriate means of tying hood to tractor (rope, cord, etc.).

OPERATION

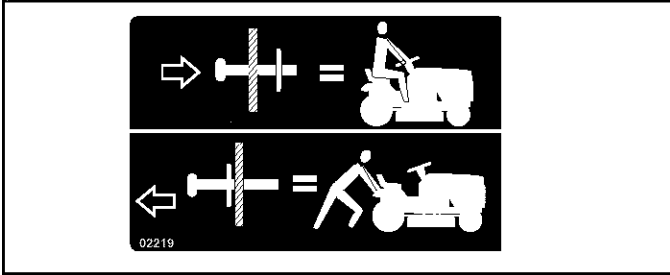

FIG. 11

TOWING CARTS AND OTHER ATTACHMENTS

Tow only the attachments that are recommended by and comply with specifications of the manufacturer of your tractor. Use common sense when towing. Too heavy of a load, while on a slope, is dangerous. Tires can lose traction with the ground and cause you to lose control of your tractor.

BEFORE STARTING THE ENGINE

CHECK ENGINE OIL LEVEL

- The engine in your tractor has been shipped, from the factory, already filled with summer weight oil.
- Check engine oil with tractor on level ground.
- Remove oil fill cap/dipstick and wipe clean, reinsert the dipstick and screw cap tight, wait for a few seconds, remove and read oil level. If necessary, add oil until "FULL" mark on dipstick is reached. Do not overfill.
- For cold weather operation you should change oil for easier starting (See "OIL VISCOSITY CHART" in the Maintenance section of this manual).
- To change engine oil, see the Maintenance section in this manual.

ADD GASOLINE

- Fill fuel tank to bottom of filler neck. Do not overfill. Use fresh, clean, regular unleaded gasoline with a minimum of 87 octane. (Use of leaded gasoline will increase carbon and lead oxide deposits and reduce valve life). Do not mix oil with gasoline. Purchase fuel in quantities that can be used within 30 days to assure fuel freshness.



CAUTION: Wipe off any spilled oil or fuel. Do not store, spill or use gasoline near an open flame.

IMPORTANT: WHEN OPERATING IN TEMPERATURES BELOW 32°F (0°C), USE FRESH, CLEAN WINTER GRADE GASOLINE TO HELP INSURE GOOD COLD WEATHER STARTING.

CAUTION: Alcohol blended fuels (called gasohol or using ethanol or methanol) can attract moisture which leads to separation and formation of acids during storage. Acidic gas can damage the fuel system of an engine while in storage. To avoid engine problems, the fuel system should be emptied before storage of 30 days or longer. Drain the gas tank, start the engine and let it run until the fuel lines and carburetor are empty. Use fresh fuel next season. See Storage Instructions for additional information. Never use engine or carburetor cleaner products in the fuel tank or permanent damage may occur.

TO START ENGINE (See Fig. 8)

When starting the engine for the first time or if the engine has run out of fuel, it will take extra cranking time to move fuel from the tank to the engine.

- Be sure freewheel control is in the transmission engaged position.
- Sit on seat in operating position, depress clutch/brake pedal and set parking brake.
- Place motion control lever in neutral (N) position.
- Move attachment clutch to "DISENGAGED" position.
- Move throttle control to fast position
- Pull choke control out for a cold engine start attempt. For a warm engine start attempt the choke control may not be needed.

NOTE: Before starting, read the warm and cold starting procedures below.

- Insert key into ignition and turn key clockwise to "START" position and release key as soon as engine starts. Do not run starter continuously for more than fifteen seconds per minute. If the engine does not start after several attempts, push choke control in, wait a few minutes and try again. If engine still does not start, pull the choke control out and retry.

WARM WEATHER STARTING (50° F and above)

- When engine starts, slowly push choke control in until the engine begins to run smoothly. If the engine starts to run roughly, pull the choke control out slightly for a few seconds and then continue to push the control in slowly.
- The attachments and ground drive can now be used. If the engine does not accept the load, restart the engine and allow it to warm up for one minute using the choke as described above.

COLD WEATHER STARTING (50° F and below)

- When engine starts, slowly push choke control in until the engine begins to run smoothly. Continue to push the choke control in small steps allowing the engine to accept small changes in speed and load, until the choke control is fully in. If the engine starts to run roughly, pull the choke control out slightly for a few seconds and then continue to push the control in slowly. This may require an engine warm-up period from several seconds to several minutes, depending on the temperature.

OPERATION

AUTOMATIC TRANSMISSION WARM UP

- Before driving the unit in cold weather, the transmission should be warmed up as follows:
 - Be sure the tractor is on level ground.
 - Place the motion control lever in neutral. Release the parking brake and let the clutch/brake slowly return to operating position.
 - Allow one minute for transmission to warm up. This can be done during the engine warm up period.
- The attachments can be used during the engine warm-up period after the transmission has been warmed up and may require the choke control be pulled out slightly.

NOTE: If at a high altitude (above 3000 feet) or in cold temperatures (below 32 F) the carburetor fuel mixture may need to be adjusted for best engine performance. See "TO ADJUST CARBURETOR" in the Service and Adjustments section of this manual.

PURGE TRANSMISSION



CAUTION: Never engage or disengage freewheel lever while the engine is running.

To ensure proper operation and performance, it is recommended that the transmission be purged before operating tractor for the first time. This procedure will remove any trapped air inside the transmission which may have developed during shipping of your tractor.

IMPORTANT: SHOULD YOUR TRANSMISSION REQUIRE REMOVAL FOR SERVICE OR REPLACEMENT, IT SHOULD BE PURGED AFTER REINSTALLATION BEFORE OPERATING THE TRACTOR.

- Place tractor safely on level surface with engine off and parking brake set.
- Disengage transmission by placing freewheel control in freewheeling position (See "TO TRANSPORT" in this section of manual).
- Sitting in the tractor seat, start engine. After the engine is running, move throttle control to slow position. With motion control lever in neutral (N) position, slowly disengage clutch/brake pedal.
- Move motion control lever to full forward position and hold for five (5) seconds. Move lever to full reverse position and hold for five (5) seconds. Repeat this procedure three (3) times.

NOTE: During this procedure there will be no movement of drive wheels. The air is being removed from hydraulic drive system.

- Move motion control lever to neutral (N) position. Shut-off engine and set parking brake.
- Engage transmission by placing freewheel control in driving position (See "TO TRANSPORT" in this section of manual).
- Sitting in the tractor seat, start engine. After the engine is running, move throttle control to half (1/2) speed. With motion control lever in neutral (N) position, slowly disengage clutch/brake pedal.

- Slowly move motion control lever forward, after the tractor moves approximately five (5) feet, slowly move motion control lever to reverse position. After the tractor moves approximately five (5) feet return the motion control lever to the neutral (N) position. Repeat this procedure with the motion control lever three (3) times.
- Your transmission is now purged and now ready for normal operation.

MOWING TIPS

- Mower should be properly leveled for best mowing performance. See "TO LEVEL MOWER HOUSING" in the Service and Adjustments section of this manual.
- The left hand side of mower should be used for trimming.
- Drive so that clippings are discharged onto the area that has been cut. Have the cut area to the right of the machine. This will result in a more even distribution of clippings and more uniform cutting.
- When mowing large areas, start by turning to the right so that clippings will discharge away from shrubs, fences, driveways, etc. After one or two rounds, mow in the opposite direction making left hand turns until finished (See Fig. 12).

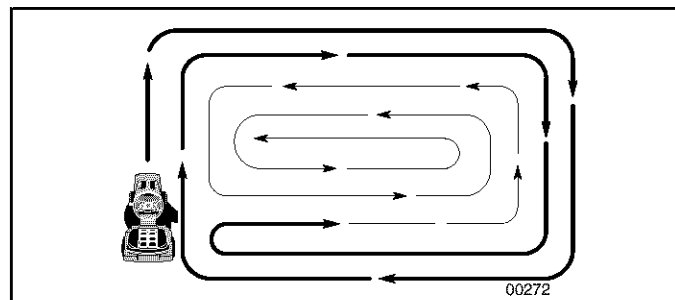

FIG. 12

- If grass is extremely tall, it should be mowed twice to reduce load and possible fire hazard from dried clippings. Make first cut relatively high; the second to the desired height.
- Do not mow grass when it is wet. Wet grass will plug mower and leave undesirable clumps. Allow grass to dry before mowing.
- **Always operate engine at full throttle when mowing** to assure better mowing performance and proper discharge of material. Regulate ground speed by selecting a low enough gear to give the mower cutting performance as well as the quality of cut desired.
- When operating attachments, select a ground speed that will suit the terrain and give best performance of the attachment being used.

MAINTENANCE

| MAINTENANCE SCHEDULE | | SERVICE DATES | | | | | | |
|----------------------|---|-----------------|---------------|------------------|------------------|-----------------|--------------|----------------|
| | | BEFORE EACH USE | EVERY 8 HOURS | EVERY 25 HOURS | EVERY 50 HOURS | EVERY 100 HOURS | EVERY SEASON | BEFORE STORAGE |
| TRACTOR | Check Brake Operation | ✓ | ✓ | | | | | |
| | Check Tire Pressure | ✓ | ✓ | | | | | |
| | Check Operator Presence and Interlock Systems | ✓ | | | | | | |
| | Check for Loose Fasteners | ✓ | | | ✓ ₅ | ✓ | | |
| | Sharpen/Replace Mower Blades | | | ✓ ₃ | | | | |
| | Lubrication Chart | | | ✓ | | ✓ | | |
| | Check Battery Level | | | ✓ ₄ | | | | |
| | Clean Battery and Terminals | | | ✓ | | ✓ | | |
| | Check Transaxle Cooling | | | ✓ | | | | |
| | Check V-Belts | | | | ✓ | | | |
| ENGINE | Check Engine Oil Level | ✓ | ✓ | | | | | |
| | Change Engine Oil (with oil filter) | | | ✓ _{1,2} | | ✓ | | |
| | Change Engine Oil (without oil filter) | | | ✓ _{1,2} | | ✓ | | |
| | Clean Air Filter | | | ✓ ₂ | | | | |
| | Clean Air Screen | | | ✓ ₂ | | | | |
| | Inspect Muffler/Spark Arrester | | | ✓ | | | | |
| | Replace Oil Filter (If equipped) | | | | ✓ _{1,2} | | | |
| | Clean Engine Cooling Fins | | | | ✓ ₂ | | | |
| | Replace Spark Plug | | | | ✓ | ✓ | | |
| | Replace Air Filter Paper Cartridge | | | | ✓ ₂ | | | |
| Replace Fuel Filter | | | | | ✓ | | | |

1 - Change more often when operating under a heavy load or in high ambient temperatures.
2 - Service more often when operating in dirty or dusty conditions.

3 - Replace blades more often when mowing in sandy soil.
4 - Not required if equipped with maintenance-free battery.
5 - Tighten front axle pivot bolt to 35 ft.-lbs. maximum. Do not overtighten.

GENERAL RECOMMENDATIONS

The warranty on this tractor does not cover items that have been subjected to operator abuse or negligence. To receive full value from the warranty, operator must maintain tractor as instructed in this manual.

Some adjustments will need to be made periodically to properly maintain your tractor.

At least once a season, check to see if you should make any of the adjustments described in the Service and Adjustments section of this manual.

- At least once a year you should replace the spark plug, clean or replace air filter, and check blades and belts for wear. A new spark plug and clean air filter assure proper air-fuel mixture and help your engine run better and last longer.

BEFORE EACH USE

- Check engine oil level.
- Check brake operation.
- Check tire pressure.
- Check operator presence and interlock systems for proper operation.
- Check for loose fasteners.

LUBRICATION CHART

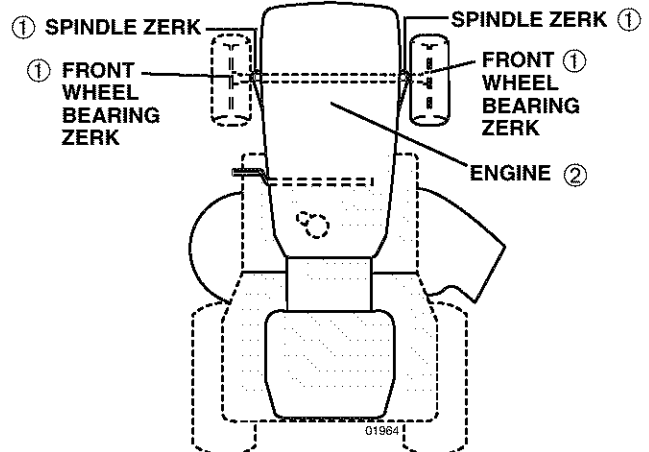

- ① General Purpose Grease
- ② Refer to Maintenance "ENGINE" Section

IMPORTANT: DO NOT OIL OR GREASE THE PIVOT POINTS WHICH HAVE SPECIAL NYLON BEARINGS. VISCOUS LUBRICANTS WILL ATTRACT DUST AND DIRT THAT WILL SHORTEN THE LIFE OF THE SELF-LUBRICATING BEARINGS. IF YOU FEEL THEY MUST BE LUBRICATED, USE ONLY A DRY, POWDERED GRAPHITE TYPE LUBRICANT SPARINGLY.

MAINTENANCE

TRACTOR

Always observe safety rules when performing any maintenance.

BRAKE OPERATION

If tractor requires more than six (6) feet stopping distance at high speed in highest gear, then brake must be adjusted. (See "TO ADJUST BRAKE" in the Service and Adjustments section of this manual).

TIRES

- Maintain proper air pressure in all tires (See "PRODUCT SPECIFICATIONS" section of this manual).
- Keep tires free of gasoline, oil, or insect control chemicals which can harm rubber.
- Avoid stumps, stones, deep ruts, sharp objects and other hazards that may cause tire damage.

NOTE: To seal tire punctures and prevent flat tires due to slow leaks, tire sealant may be purchased from your local parts dealer. Tire sealant also prevents tire dry rot and corrosion.

OPERATOR PRESENCE SYSTEM

Be sure operator presence and interlock systems are working properly. If your tractor does not function as described, repair the problem immediately.

- The engine should not start unless the clutch/brake pedal is fully depressed and attachment clutch control is in the disengaged position.
- When the engine is running, any attempt by the operator to leave the seat without first setting the parking brake should shut off the engine.
- When the engine is running and the attachment clutch is engaged, any attempt by the operator to leave the seat should shut off the engine.
- The attachment clutch should never operate unless the operator is in the seat.

BLADE CARE

For best results mower blades must be kept sharp. Replace bent or damaged blades.

BLADE REMOVAL (See Fig. 13)

- Raise mower to highest position to allow access to blades.

NOTE: Protect your hands with gloves and/or wrap blade with heavy cloth.

- Remove blade bolt by turning counterclockwise.
- Install new or resharpened blade with stamped "THIS SIDE UP" facing deck and mandrel assembly.

IMPORTANT: TO ENSURE PROPER ASSEMBLY, CENTER HOLE IN BLADE MUST ALIGN WITH STAR ON MANDREL ASSEMBLY.

- Install and tighten blade bolt securely (45-55 Ft. Lbs. torque).

IMPORTANT: SPECIAL BLADE BOLT HEAT TREATED.

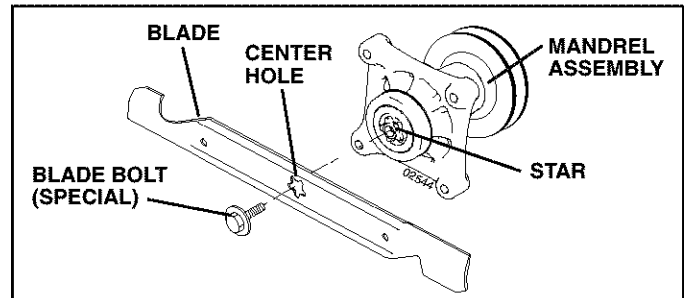

FIG. 13

TO SHARPEN BLADE (See Fig. 14)

NOTE: We do not recommend sharpening blade - but if you do, be sure the blade is balanced.

Care should be taken to keep the blade balanced. An unbalanced blade will cause excessive vibration and eventual damage to mower and engine.

- The blade can be sharpened with a file or on a grinding wheel. Do not attempt to sharpen while on the mower.
- To check blade balance, you will need a 5/8" diameter steel bolt, pin, or a cone balancer. (When using a cone balancer, follow the instructions supplied with balancer.)

NOTE: Do not use a nail for balancing blade. The lobes of the center hole may appear to be centered, but are not.

- Slide blade on to an unthreaded portion of the steel bolt or pin and hold the bolt or pin parallel with the ground. If blade is balanced, it should remain in a horizontal position. If either end of the blade moves downward, sharpen the heavy end until the blade is balanced.

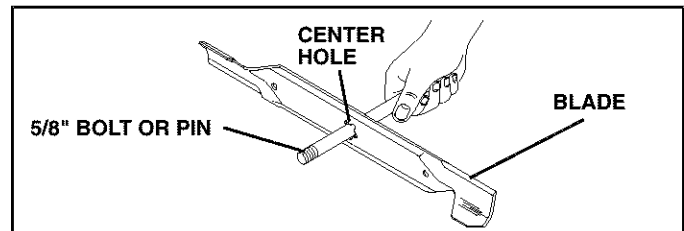

FIG. 14

BATTERY

Your tractor has a battery charging system which is sufficient for normal use. However, periodic charging of the battery with an automotive charger will extend its life.

- Keep battery and terminals clean.
- Keep battery bolts tight.
- Keep small vent holes open.
- Recharge at 6-10 amperes for 1 hour.

NOTE: The original equipment battery on your tractor is maintenance free. Do not attempt to open or remove caps or covers. Adding or checking level of electrolyte is not necessary.

TO CLEAN BATTERY AND TERMINALS

Corrosion and dirt on the battery and terminals can cause the battery to "leak" power.

MAINTENANCE

- Remove terminal guard.
- Disconnect BLACK battery cable first then RED battery cable and remove battery from tractor.
- Rinse the battery with plain water and dry.
- Clean terminals and battery cable ends with wire brush until bright.
- Coat terminals with grease or petroleum jelly.
- Reinstall battery (See "REPLACING BATTERY" in the SERVICE AND ADJUSTMENTS section of this manual).

V-BELTS

Check V-belts for deterioration and wear after 100 hours of operation and replace if necessary. The belts are not adjustable. Replace belts if they begin to slip from wear.

TRANSAXLE COOLING

The transmission fan and cooling fins should be kept clean to assure proper cooling.

Do not attempt to clean fan or transmission while engine is running or while the transmission is hot. To prevent possible damage to seals, do not use high pressure water or steam to clean transaxle.

- Inspect cooling fan to be sure fan blades are intact and clean.
- Inspect cooling fins for dirt, grass clippings and other materials. To prevent damage to seals, do not use compressed air or high pressure sprayer to clean cooling fins.

TRANSAXLE PUMP FLUID

The transaxle was sealed at the factory and fluid maintenance is not required for the life of the transaxle. Should the transaxle ever leak or require servicing, contact your nearest authorized service center/department.

ENGINE

LUBRICATION

Only use high quality detergent oil rated with API service classification SF-SJ. Select the oil's SAE viscosity grade according to your expected operating temperature.

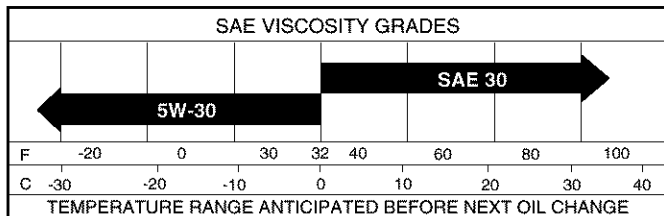

FIG. 15

NOTE: Although multi-viscosity oils (5W30, 10W30 etc.) improve starting in cold weather, these multi-viscosity oils will result in increased oil consumption when used above 32°F. Check your engine oil level more frequently to avoid possible engine damage from running low on oil.

Change the oil after every 50 hours of operation or at least once a year if the tractor is not used for 50 hours in one year.

Check the crankcase oil level before starting the engine and after each eight (8) hours of operation. Tighten oil fill cap/dipstick securely each time you check the oil level.

TO CHANGE ENGINE OIL (See Figs. 15 and 16)

Determine temperature range expected before oil change. All oil must meet API service classification SF-SJ.

- Be sure tractor is on level surface.
- Oil will drain more freely when warm.
- Catch oil in a suitable container.
- Remove oil fill cap/dipstick. Be careful not to allow dirt to enter the engine when changing oil.
- Remove yellow cap from bottom fitting of drain valve and install the drain tube onto the fitting.

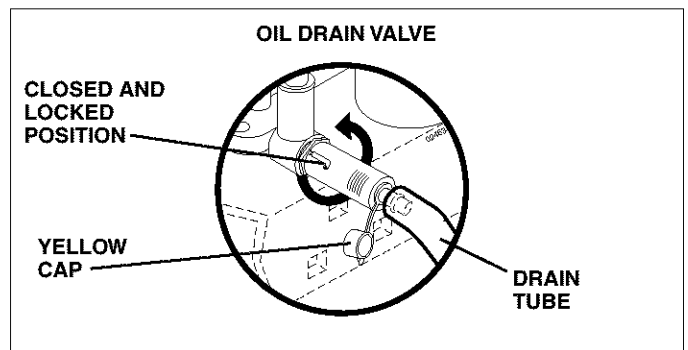

FIG. 16

- Unlock drain valve by pushing inward and turning counterclockwise.
- To open, pull out on the drain valve.
- After oil has drained completely, close and lock the drain valve by pushing inward and turning clockwise until the pin is in the locked position as shown.
- Remove the drain tube and replace the cap onto to the bottom fitting of the drain valve.
- Refill engine with oil through oil fill dipstick tube. Pour slowly. Do not overfill. For approximate capacity see "PRODUCT SPECIFICATIONS" section of this manual.
- Use gauge on oil fill cap/dipstick for checking level. Insert dipstick into the tube and rest the oil fill cap on the tube. Do not thread the cap onto the tube when taking reading. Keep oil at "FULL" line on dipstick. Tighten cap onto the tube securely when finished.

CLEAN AIR SCREEN

Air screen must be kept free of dirt and chaff to prevent engine damage from overheating. Clean with a wire brush or compressed air to remove dirt and stubborn dried gum fibers.

MAINTENANCE

CLEAN AIR INTAKE/COOLING AREAS

To insure proper cooling, make sure the grass screen, cooling fins, and other external surfaces of the engine are kept clean at all times.

Every 100 hours of operation (more often under extremely dusty, dirty conditions), remove the blower housing and other cooling shrouds. Clean the cooling fins and external surfaces as necessary. Make sure the cooling shrouds are reinstalled.

NOTE: Operating the engine with a blocked grass screen, dirty or plugged cooling fins, and/or cooling shrouds removed will cause engine damage due to overheating.

AIR FILTER

Your engine will not run properly using a dirty air filter. Service air cleaner more often under dusty conditions. See Engine Manual.

ENGINE OIL FILTER

Replace the engine oil filter every season or every other oil change if the tractor is used more than 100 hours in one year.

MUFFLER

Inspect and replace corroded muffler and spark arrester (if equipped) as it could create a fire hazard and/or damage.

SPARK PLUGS

Replace spark plugs at the beginning of each mowing season or after every 100 hours of operation, whichever occurs first. Spark plug type and gap setting are shown in "PRODUCT SPECIFICATIONS" section of this manual.

IN-LINE FUEL FILTER (See Fig. 17)

The fuel filter should be replaced once each season. If fuel filter becomes clogged, obstructing fuel flow to carburetor, replacement is required.

- With engine cool, remove filter and plug fuel line sections.
- Place new fuel filter in position in fuel line with arrow pointing towards carburetor.
- Be sure there are no fuel line leaks and clamps are properly positioned.
- Immediately wipe up any spilled gasoline.

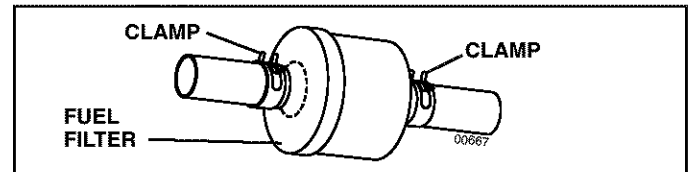

FIG. 17

CLEANING

- Clean engine, battery, seat, finish, etc. of all foreign matter.
- Keep finished surfaces and wheels free of all gasoline, oil, etc.
- Protect painted surfaces with automotive type wax.

We do not recommend using a garden hose or pressure washer to clean your tractor unless the engine and transmission are covered to keep water out. Water in engine or transmission will shorten the useful life of your tractor. Use compressed air or a leaf blower to remove grass, leaves and trash from tractor and mower.

SERVICE AND ADJUSTMENTS



WARNING: TO AVOID SERIOUS INJURY, BEFORE PERFORMING ANY SERVICE OR ADJUSTMENTS:

- Depress clutch/brake pedal fully and set parking brake.
- Place motion control lever in neutral (N) position.
- Place attachment clutch in "DISENGAGED" position.
- Turn ignition key to "STOP" and remove key.
- Make sure the blades and all moving parts have completely stopped.
- Disconnect spark plug wire from spark plug and place wire where it cannot come in contact with plug.

TRACTOR

TO REMOVE MOWER (See Fig. 18)

- Place attachment clutch in "DISENGAGED" position.
- If equipped, turn height adjustment knob to lowest setting.
- Lower mower to its lowest position.
- Remove retainer spring holding anti-swaybar to chassis bracket and disengage anti-swaybar from bracket.
- Remove four retainer springs from front plate assembly and remove plate.
- Remove retainer springs from suspension arms at deck and disengage arms from deck.
- Raise attachment lift to its highest position.
- Slide mower forward and remove belt from electric clutch pulley.
- Slide mower out from under right side of tractor.

TO INSTALL MOWER

Be sure tractor is on level surface and mower suspension arms are raised with attachment lift control. Engage parking brake.

- Swing anti-sway bar to left side of mower deck.
- Slide mower under tractor with deflector shield to right side of tractor.

IMPORTANT: CHECK BELT FOR PROPER ROUTING IN ALL MOWER PULLEY GROOVES.

- If equipped, turn height adjustment knob counter-clockwise until it stops.
- Lower mower linkage with attachment lift control.
- Install belt into electric clutch pulley groove.
- Place the suspension arms on outward pointing deck pins. Retain with double loop retainer spring with loops up as shown.
- Install front plate assembly to tractor suspension brackets and retain with single loop retainer springs as shown.

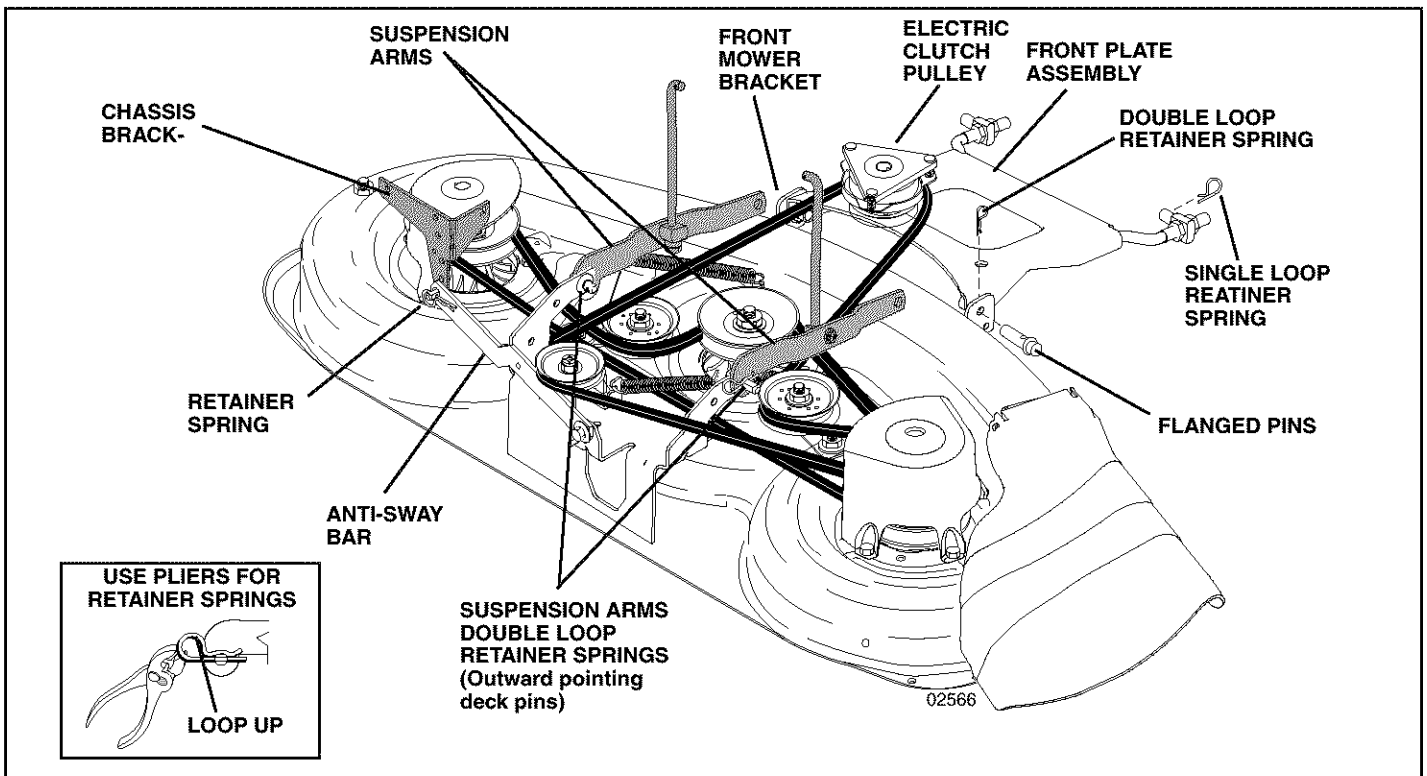

FIG. 18

SERVICE AND ADJUSTMENTS

- Position front plate assembly between front mower brackets. Raise deck and plate assembly to align holes and insert flanged pins. Secure pins with double loop retainer springs between the plate and mower brackets.

NOTE: To assist in locating hole in flanged pin, the hole in pin is inline with notch on head of pin. If necessary, move mower side-to-side to give space between plate and mower brackets.

IMPORTANT: CHECK BELT FOR PROPER ROUTING IN ALL MOWER PULLEY GROOVES.

- Connect anti-sway bar to chassis bracket under left footrest and retain with double loop retainer spring.
- If equipped, turn height adjustment knob clockwise to remove slack from mower suspension.
- Raise deck to highest position.

TO LEVEL MOWER HOUSING

Adjust the mower while tractor is parked on level ground or driveway. Make sure tires are properly inflated (See "PRODUCT SPECIFICATIONS" section of this manual). If tires are over or underinflated, you will not properly adjust your mower.

SIDE-TO-SIDE ADJUSTMENT (See Figs. 19 and 20)

- Raise mower to its highest position.
- Measure height from bottom edge of mower to ground level at front corners of mower. Distance "A" on both sides of mower should be the same.
- If adjustment is necessary, make adjustment on one side of mower only.
- To raise one side of mower, tighten lift link adjustment nut on that side.
- To lower one side of mower, loosen lift link adjustment nut on that side.

NOTE: Each full turn of adjustment nut will change mower height about 3/16".

- Recheck measurements after adjusting.

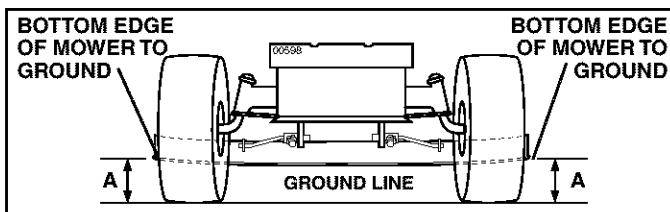

FIG. 19

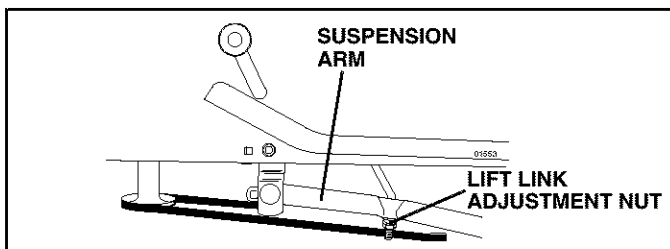

FIG. 20

FRONT-TO-BACK ADJUSTMENT (See Figs. 21 and 22)

IMPORTANT: DECK MUST BE LEVEL SIDE-TO-SIDE. IF THE FOLLOWING FRONT-TO-BACK ADJUSTMENT IS NECESSARY, BE SURE TO ADJUST BOTH FRONT LINKS EQUALLY SO MOWER WILL STAY LEVEL SIDE-TO-SIDE.

To obtain the best cutting results, the mower blades should be adjusted so the front tip is approximately 1/8" to 1/2" lower than the rear tip when the mower is in its highest position.



CAUTION: Blades are sharp. Protect your hands with gloves and/or wrap blade with heavy cloth.

Check adjustment on right side of tractor. Position any blade so the tip is pointing straight forward. Measure distance "B" at front and rear tip of the blade.

- Before making any necessary adjustments, check that both front plate links are equal in length.
- If links are not equal in length, adjust one link to same length as other link.
- To lower front of blade, loosen nut "C" on both front links an equal number of turns.

NOTE: Each full turn of nut "C" will change distance "B" by approximately 3/16".

- When distance "B" is 1/8" to 1/2" lower at front than rear, tighten nut "D" against trunnion on both front links.
- To raise front of blade, loosen nut "D" from trunnion on both front links. Tighten nut "C" on both front links an equal number of turns. The two front links must remain equal in length.
- When distance "B" is 1/8" to 1/2" lower at front than rear, tighten nut "D" against trunnion on both front links.
- Recheck side-to-side adjustment.

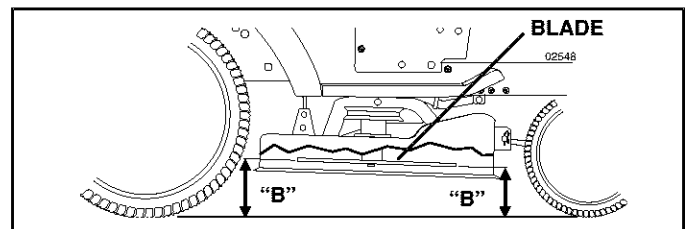

FIG. 21

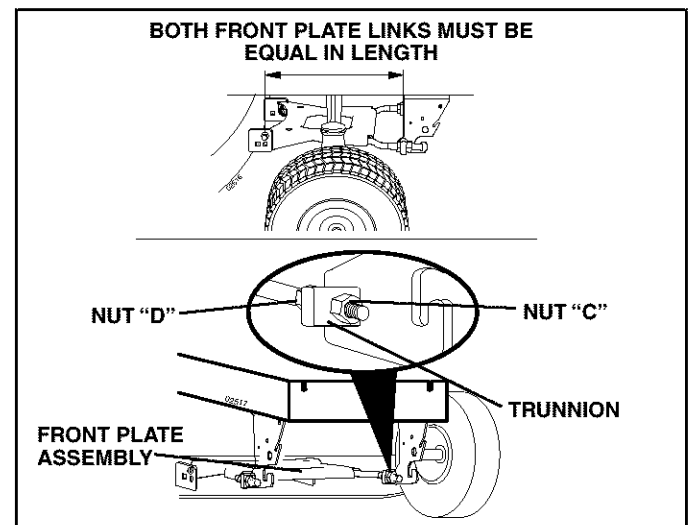

FIG. 22

SERVICE AND ADJUSTMENTS

TO REPLACE MOWER DRIVE BELT

MOWER DRIVE BELT REMOVAL (See Fig. 23)

- Park tractor on a level surface. Engage parking brake.
- Lower mower to its lowest position.
Remove screws from R.H. mandrel cover and remove cover.
- Remove any dirt or grass clippings which may have accumulated around mandrels and entire upper deck surface.
- Disconnect R.H. suspension arm from rear deck bracket by removing retainer spring.
- Roll belt over the top of R.H. mandrel pulley carefully.
- Remove belt from electric clutch pulley.
- Remove belt from idler pulleys.
- Check primary idler arm and two idlers to see that they rotate freely.
- Be sure spring is securely hooked to primary idler arm and spring arm.

MOWER DRIVE BELT INSTALLATION (See Fig. 23)

- Install belt in both idlers.
- Install new belt onto electric clutch pulley.
- Roll belt into upper groove of R.H. mandrel pulley carefully.
- Carefully check belt routing making sure belt is in the grooves correctly.
- Reconnect R.H. suspension arm to rear deck bracket with retainer spring.
- Reassemble R.H. mandrel cover.

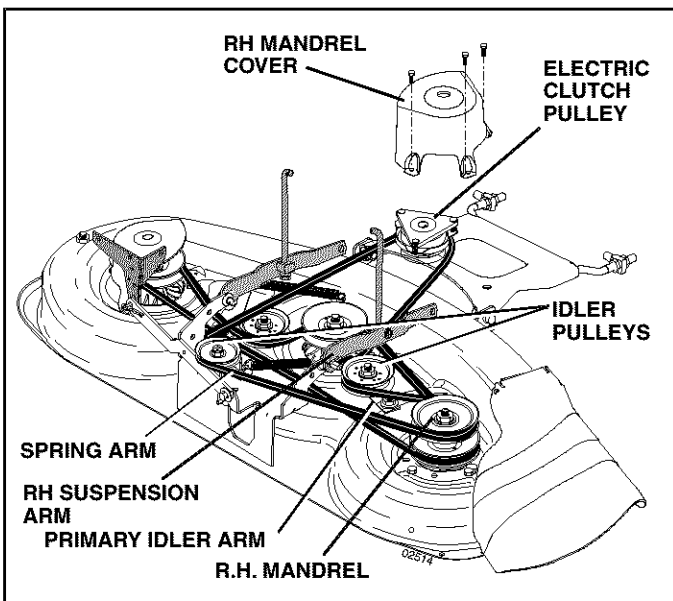

FIG. 23

TO REPLACE MOWER BLADE (SECONDARY) DRIVE BELT (See Fig. 24)

Park the tractor on level surface. Engage parking brake.

- Remove mower (See "TO REMOVE MOWER" in this section of manual).
- Remove screws from R.H. and L.H. mandrel covers and remove covers.

REMOVE MOWER DRIVE BELT

(Refer to "TO REMOVE MOWER DRIVE BELT" illustration in this section of manual).

- Carefully roll belt over the top of R.H. mandrel pulley.
- Remove belt from idler pulleys.
- Check primary idler arm and two idlers to see that they rotate freely.
- Be sure spring is securely hooked to primary idler arm and spring arm.

REMOVE MOWER BLADE (SECONDARY) DRIVE BELT

- Carefully roll belt off L.H. mandrel pulley.
- Remove belt from center mandrel pulley, idler pulley, and R.H. mandrel pulley.
- Remove any dirt or grass which may have accumulated around mandrels and entire upper deck surface.
- Check secondary idler arm and idler pulley to see that they rotate freely.
- Be sure spring is hooked in secondary idler arm and secondary spring arm.

INSTALL NEW MOWER BLADE (SECONDARY) DRIVE BELT

- Install new belt in lower groove of R.H. mandrel pulley, idler pulley, and center mandrel pulley as shown.
- Carefully roll belt over L.H. mandrel pulley. Make sure belt is in all grooves properly.

REINSTALL MOWER DRIVE BELT

(Refer to "TO REMOVE MOWER DRIVE BELT" illustration in this section of manual).

- Install belt into upper groove of R.H. mandrel pulley and around both idlers. Pull belt to front of mower to remove slack.
- Reinstall mandrel covers and securely tighten all screws.
- Carefully check belt routing making sure belt is in all grooves correctly.
- Reinstall mower to tractor (See "TO INSTALL MOWER" in this section of manual).

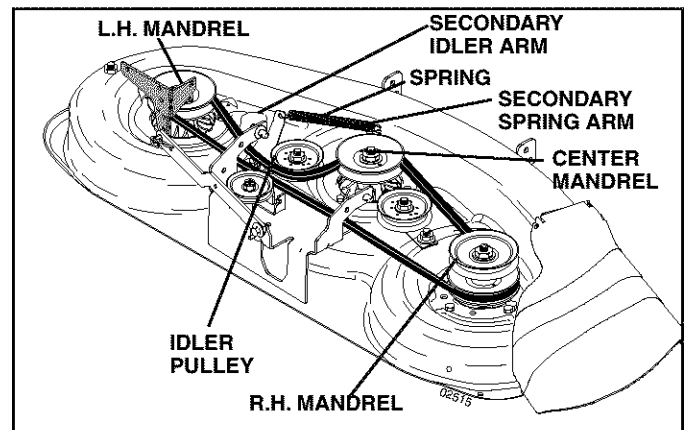

FIG. 24

SERVICE AND ADJUSTMENTS

TO CHECK AND ADJUST BRAKE (See Fig. 25)

Your tractor is equipped with an adjustable brake system which is mounted on the right side of the transaxle.

If tractor requires more than five (5) feet to stop at highest speed in highest gear on a level, dry concrete or paved surface, then brake must be checked and adjusted.

TO CHECK BRAKE

- Park tractor on a level, dry concrete or paved surface, depress clutch/brake pedal all the way down and engage parking brake.
- Disengage transmission by placing freewheel control in "transmission disengaged" position. Pull freewheel control out and into the slot and release so it is held in the disengaged position.

The rear wheels must lock and skid when you try to manually push the tractor forward. If the rear wheels rotate, the brake needs to be adjusted or the pads need to be replaced.

TO ADJUST BRAKE

- Depress clutch/brake pedal all the way down and engage parking brake.
- Measure distance between brake operating arm and nut "A" on brake rod.
- If distance is other than 1-9/16", loosen jam nut and turn nut "A" until distance becomes 1-9/16". Retighten jam nut against nut "A".
- Engage transmission by placing freewheel control in "transmission engaged" position.
- Road test tractor for proper stopping distance as stated above. Readjust if necessary. If stopping distance is still greater than five (5) feet in highest gear, further maintenance is necessary. Replace brake pads or contact a qualified service center.

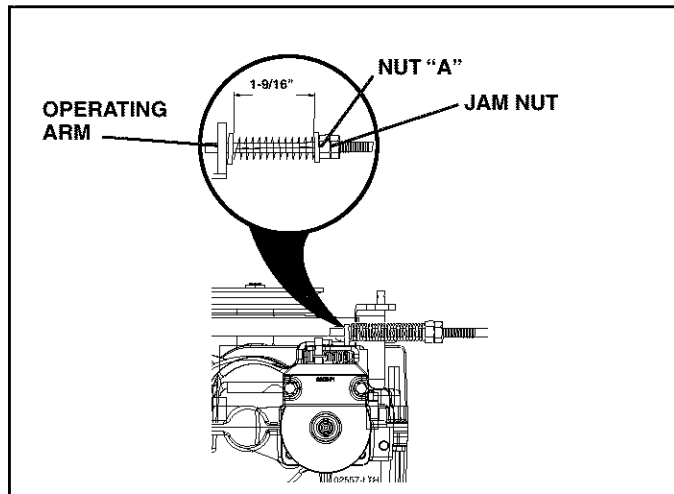

FIG. 25

TO REPLACE MOTION DRIVE BELT (See Fig. 26)

Park the tractor on level surface. Engage parking brake. For assistance, there is a belt installation guide decal on bottom side of left footrest.

BELT REMOVAL -

- Remove mower (See "TO REMOVE MOWER" in this section of manual).

NOTE: Observe entire motion drive belt and position of all belt guides and keepers.

- Disconnect clutch wire harness.
- Remove clutch locator.
- Remove belt from stationary idler and clutching idler.
- Remove belt downward from engine pulley and around electric clutch.
- Pull belt slack toward rear of tractor. Carefully remove belt upwards from transmission input pulley.
- Remove belt from center span keeper and pull belt away from tractor.

BELT INSTALLATION -

- Carefully work new belt down onto the input pulley.
- Slide belt into the center span keeper.
- Pull belt toward front of tractor and roll belt around electric clutch and onto engine pulley.
- Install belt through stationary idler and clutching idler.
- Reinstall clutch locator and tighten nut securely.
- Reconnect clutch harness.
- Make sure belt is in all pulley grooves and inside all belt guides and keepers.
- Install mower (See "TO INSTALL MOWER" in this section of manual).

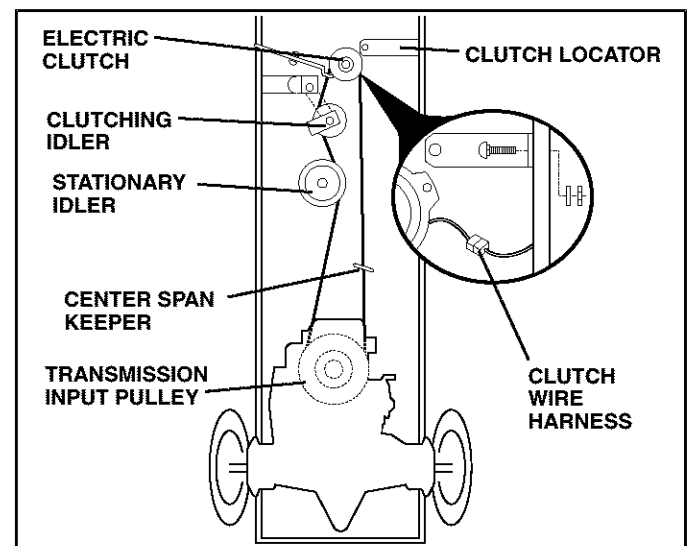

FIG. 26

SERVICE AND ADJUSTMENTS

TRANSAXLE MOTION CONTROL LEVER NEUTRAL ADJUSTMENT (See Fig. 27)

The motion control lever has been preset at the factory and adjustment should not be necessary.

- Loosen adjustment bolt in front of the right rear wheel, and lightly tighten.
- Start engine and move motion control lever until tractor does not move forward or backward.
- Hold motion control lever in that position and turn engine off.
- While holding motion control lever in place, loosen the adjustment bolt.
- Move motion control lever to the neutral (N) (lock gate) position.
- Tighten adjustment bolt securely.

NOTE: If additional clearance is needed to get to adjustment bolt, move mower deck height to the lowest position.

After above adjustment is made, if the tractor still creeps forward or backward while motion control lever is in neutral position, follow these steps:

- Loosen the adjustment bolt.
- Move the motion control lever 1/4 to 1/2 inch in the direction it is trying to creep.
- Tighten adjustment bolt securely.
- Start engine and test.
- If tractor still creeps, repeat above steps until satisfied.

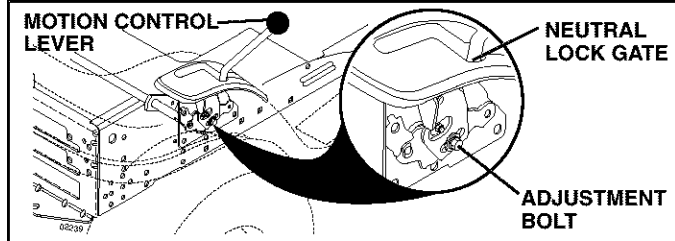

FIG. 27

TRANSMISSION REMOVAL/REPLACEMENT

Should your transmission require removal for service or replacement, it should be purged after reinstallation and before operating the tractor. See "PURGETRANSMISSION" in the Operation section of this manual.

TO ADJUST STEERING WHEEL ALIGNMENT

If steering wheel crossbars are not horizontal (left to right) when wheels are positioned straight forward, remove steering wheel and reassemble per instructions in the Assembly section of this manual.

FRONT WHEEL TOE-IN/CAMBER

The front wheel toe-in and camber are not adjustable on your tractor. If damage has occurred to affect the front wheel toe-in or camber, contact your nearest authorized service center/department.

TO REMOVE WHEEL FOR REPAIRS (See Fig. 28)

- Block up axle securely.
- Remove axle cover, retaining ring and washers to allow wheel removal (rear wheel contains a square key - Do not lose).
- Repair tire and reassemble.
- On rear wheels only: align grooves in rear wheel hub and axle. Insert square key.
- Replace washers and snap retaining ring securely in axle groove.
- Replace axle cover.

NOTE: To seal tire punctures and prevent flat tires due to slow leaks, tire sealant may be purchased from your local parts dealer. Tire sealant also prevents tire dry rot and corrosion.

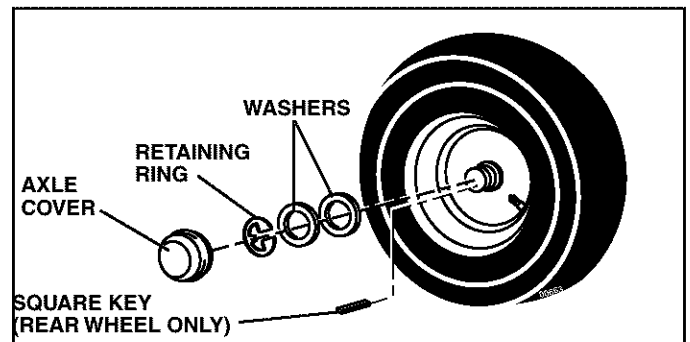

FIG. 28

TO START ENGINE WITH A WEAK BATTERY(See Fig. 29)



WARNING: Lead-acid batteries generate explosive gases. Keep sparks, flame and smoking materials away from batteries. Always wear eye protection when around batteries.

If your battery is too weak to start the engine, it should be recharged. (See "BATTERY" in the MAINTENANCE section of this manual).

If "jumper cables" are used for emergency starting, follow this procedure:

IMPORTANT: YOUR TRACTOR IS EQUIPPED WITH A 12 VOLT SYSTEM. THE OTHER VEHICLE MUST ALSO BE A 12 VOLT SYSTEM. DO NOT USE YOUR TRACTOR BATTERY TO START OTHER VEHICLES.

TO ATTACH JUMPER CABLES -

- Connect one end of the RED cable to the POSITIVE (+) terminal of each battery(A-B), taking care not to short against tractor chassis.
- Connect one end of the BLACK cable to the NEGATIVE (-) terminal (C) of fully charged battery.
- Connect the other end of the BLACK cable (D) to good chassis ground, away from fuel tank and battery.

TO REMOVE CABLES, REVERSE ORDER -

- BLACK cable first from chassis and then from the fully charged battery.
- RED cable last from both batteries.

SERVICE AND ADJUSTMENTS

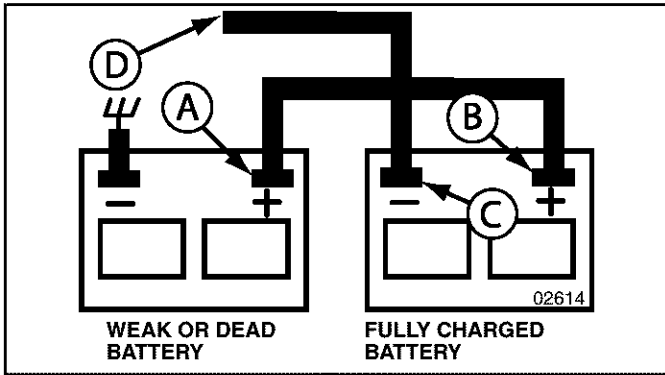

FIG. 29

REPLACING BATTERY (See Fig. 30)



WARNING: Do not short battery terminals by allowing a wrench or any other object to contact both terminals at the same time. Before connecting battery, remove metal bracelets, wristwatch bands, rings, etc. Positive terminal must be connected first to prevent sparking from accidental grounding.

- Lift hood to raised position.
- Disconnect BLACK battery cable first then RED battery cable and carefully remove battery from tractor.
- Install new battery with terminals in same position as old battery.
- First connect RED battery cable to positive (+) terminal with hex bolt and keps nut as shown. Tighten securely. Slide terminal cover over terminal.
- Connect BLACK grounding cable to negative (-) terminal with remaining hex bolt and keps nut. Tighten securely.

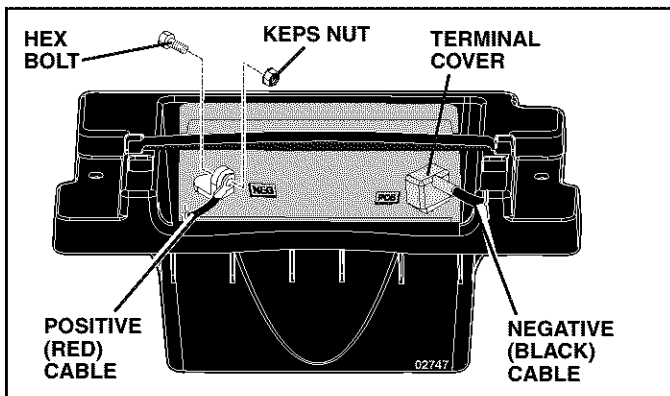

FIG. 30

TO REPLACE HEADLIGHT BULB

- Raise hood.
- Pull bulb holder out of the hole in the backside of the grill.
- Replace bulb in holder and push bulb holder securely back into the hole in the backside of the grill.
- Close hood.

INTERLOCKS AND RELAYS

Loose or damaged wiring may cause your tractor to run poorly, stop running, or prevent it from starting.

- Check wiring. See electrical wiring diagram in the Repair Parts section.

TO REPLACE FUSE

Replace with 20 amp automotive-type plug-in fuse. The fuse holder is located behind the dash.

TO REMOVE HOOD AND GRILL ASSEMBLY (See Fig. 31)

- Raise hood.
- Unsnap headlight wire connector.
- Stand in front of tractor. Grasp hood at sides, tilt toward engine and lift off of tractor.
- To replace, reverse above procedures.

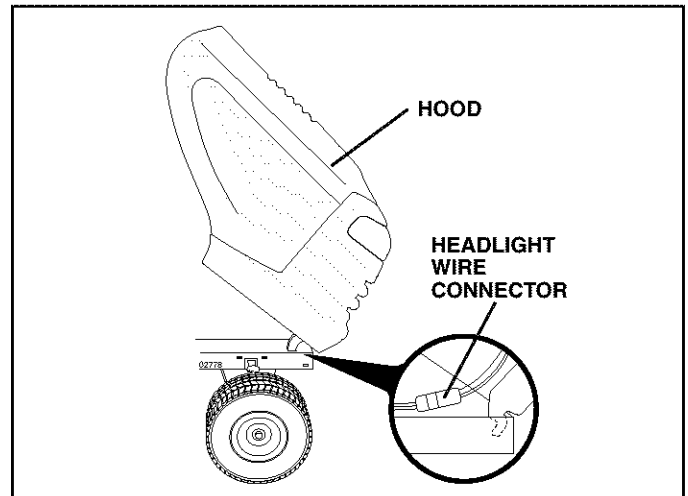

FIG. 31

ENGINE

TO ADJUST THROTTLE CONTROL CABLE

The throttle control has been preset at the factory and adjustment should not be necessary. If adjustment is necessary, see engine manual.

TO ADJUST CHOKE CONTROL

The choke control has been preset at the factory and adjustment should not be necessary. If adjustment is necessary, see engine manual.

TO ADJUST CARBURETOR

Your carburetor is not adjustable. If your engine does not operate properly due to suspected carburetor problems, take your tractor to an authorized service center for repair and/or adjustment.

STORAGE

Immediately prepare your tractor for storage at the end of the season or if the tractor will not be used for 30 days or more.



WARNING: Never store the tractor with gasoline in the tank inside a building where fumes may reach an open flame or spark. Allow the engine to cool before storing in any enclosure.

TRACTOR

Remove mower from tractor for winter storage. When mower is to be stored for a period of time, clean it thoroughly, remove all dirt, grease, leaves, etc. Store in a clean, dry area.

- Clean entire tractor (See “CLEANING” in the Maintenance section of this manual).
- Inspect and replace belts, if necessary (See belt replacement instructions in the Service and Adjustments section of this manual).
- Lubricate as shown in the Maintenance section of this manual.
- Be sure that all nuts, bolts and screws are securely fastened. Inspect moving parts for damage, breakage and wear. Replace if necessary.
- Touch up all rusted or chipped paint surfaces; sand lightly before painting.

BATTERY

- Fully charge the battery for storage.
- After a period of time in storage, battery may require recharging.
- To help prevent corrosion and power leakage during long periods of storage, battery cables should be disconnected and battery cleaned thoroughly (see “TO CLEAN BATTERY AND TERMINALS” in the Maintenance section of this manual).
- After cleaning, leave cables disconnected and place cables where they cannot come in contact with battery terminals.
- If battery is removed from tractor for storage, do not store battery directly on concrete or damp surfaces.

ENGINE

FUEL SYSTEM

IMPORTANT: IT IS IMPORTANT TO PREVENT GUM DEPOSITS FROM FORMING IN ESSENTIAL FUEL SYSTEM PARTS SUCH AS CARBURETOR, FUEL FILTER, FUEL HOSE, OR TANK DURING STORAGE. ALSO, EXPERIENCE INDICATES THAT ALCOHOL BLENDED FUELS (CALLED GASOHOL OR USING ETHANOL OR METHANOL) CAN ATTRACT MOISTURE WHICH LEADS TO SEPARATION AND FORMATION OF ACIDS DURING STORAGE. ACIDIC GAS CAN DAMAGE THE FUEL SYSTEM OF AN ENGINE WHILE IN STORAGE.

- Empty the fuel tank by starting the engine and let it run until the fuel lines and carburetor are empty.
- Never use engine or carburetor cleaner products in the fuel tank or permanent damage may occur.
- Use fresh fuel next season.

NOTE: Fuel stabilizer is an acceptable alternative in minimizing the formation of fuel gum deposits during storage. Add stabilizer to gasoline in fuel tank or storage container. Always follow the mix ratio found on stabilizer container. Run engine at least 10 minutes after adding stabilizer to allow the stabilizer to reach the carburetor. Do not empty the gas tank and carburetor if using fuel stabilizer.

ENGINE OIL

Drain oil (with engine warm) and replace with clean engine oil. (See “ENGINE” in the Maintenance section of this manual).

CYLINDER(S)

- Remove spark plug(s).
- Pour one ounce of oil through spark plug hole(s) into cylinder(s).
- Turn ignition key to “START” position for a few seconds to distribute oil.
- Replace with new spark plug(s).

OTHER

- Do not store gasoline from one season to another.
- Replace your gasoline can if your can starts to rust. Rust and/or dirt in your gasoline will cause problems.
- If possible, store your tractor indoors and cover it to give protection from dust and dirt.
- Cover your tractor with a suitable protective cover that does not retain moisture. Do not use plastic. Plastic cannot breathe which allows condensation to form and will cause your tractor to rust.

IMPORTANT: NEVER COVER TRACTOR WHILE ENGINE AND EXHAUST AREAS ARE STILL WARM.

TROUBLESHOOTING POINTS

| PROBLEM | CAUSE | CORRECTION |
|---|---|--|
| Will not start | <ol style="list-style-type: none"> 1. Out of fuel. 2. Engine not "CHOKED" properly. 3. Engine flooded. 4. Bad spark plug. 5. Dirty air filter. 6. Dirty fuel filter. 7. Water in fuel. 8. Loose or damaged wiring. 9. Carburetor out of adjustment. 10. Engine valves out of adjustment. | <ol style="list-style-type: none"> 1. Fill fuel tank. 2. See "TO START ENGINE" in Operation section. 3. Wait several minutes before attempting to start. 4. Replace spark plug. 5. Clean/replace air filter. 6. Replace fuel filter. 7. Empty fuel tank and carburetor, refill tank with fresh gasoline and replace fuel filter. 8. Check all wiring. 9. See "To Adjust Carburetor" in Service Adjustments section. 10. Contact an authorized service center/department. |
| Hard to start | <ol style="list-style-type: none"> 1. Dirty air filter. 2. Bad spark plug. 3. Weak or dead battery. 4. Dirty fuel filter. 5. Stale or dirty fuel. 6. Loose or damaged wiring. 7. Carburetor out of adjustment. 8. Engine valves out of adjustment. | <ol style="list-style-type: none"> 1. Clean/replace air filter. 2. Replace spark plug. 3. Recharge or replace battery. 4. Replace fuel filter. 5. Empty fuel tank and refill tank with fresh, clean gasoline. 6. Check all wiring. 7. See "To Adjust Carburetor" in Service Adjustments section. 8. Contact an authorized service center/department. |
| Engine will not turn over | <ol style="list-style-type: none"> 1. Brake pedal not depressed. 2. Attachment clutch is engaged. 3. Weak or dead battery. 4. Blown fuse. 5. Corroded battery terminals. 6. Loose or damaged wiring. 7. Faulty ignition switch. 8. Faulty solenoid or starter. 9. Faulty operator presence switch(es). | <ol style="list-style-type: none"> 1. Depress brake pedal. 2. Disengage attachment clutch. 3. Recharge or replace battery. 4. Replace fuse. 5. Clean battery terminals. 6. Check all wiring. 7. Check/replace ignition switch. 8. Check/replace solenoid or starter. 9. Contact an authorized service center/department. |
| Engine clicks but will not start | <ol style="list-style-type: none"> 1. Weak or dead battery. 2. Corroded battery terminals. 3. Loose or damaged wiring. 4. Faulty solenoid or starter. | <ol style="list-style-type: none"> 1. Recharge or replace battery. 2. Clean battery terminals. 3. Check all wiring. 4. Check/replace solenoid or starter. |
| Loss of power | <ol style="list-style-type: none"> 1. Cutting too much grass/too fast. 2. Throttle in "CHOKE" position. 3. Build-up of grass, leaves and trash under mower. 4. Dirty air filter. 5. Low oil level/dirty oil. 6. Faulty spark plug. 7. Dirty fuel filter. 8. Stale or dirty fuel. 9. Water in fuel. 10. Spark plug wire loose. 11. Dirty engine air screen/fins. 12. Dirty/clogged muffler. 13. Loose or damaged wiring. 14. Carburetor out of adjustment. 15. Engine valves out of adjustment. | <ol style="list-style-type: none"> 1. Raise cutting height/reduce speed. 2. Adjust throttle control. 3. Clean underside of mower housing. 4. Clean/replace air filter. 5. Check oil level/change oil. 6. Clean and regap or change spark plug. 7. Replace fuel filter. 8. Empty fuel tank and refill tank with fresh, clean gasoline. 9. Empty fuel tank and carburetor, refill tank with fresh gasoline and replace fuel filter. 10. Connect and tighten spark plug wire. 11. Clean engine air screen/fins. 12. Clean/replace muffler. 13. Check all wiring. 14. See "To Adjust Carburetor" in Service Adjustments section. 15. Contact an authorized service center/department. |
| Excessive vibration | <ol style="list-style-type: none"> 1. Worn, bent or loose blade. 2. Bent blade mandrel. 3. Loose/damaged part(s). | <ol style="list-style-type: none"> 1. Replace blade. Tighten blade bolt. 2. Replace blade mandrel. 3. Tighten loose part(s). Replace damaged parts. |

TROUBLESHOOTING POINTS

| PROBLEM | CAUSE | CORRECTION |
|---|--|---|
| Engine continues to run when operator leaves seat with attachment clutch engaged | <ol style="list-style-type: none"> 1. Faulty operator-safety presence control system. | <ol style="list-style-type: none"> 1. Check wiring, switches and connections. If not corrected, contact an authorized service center/department. |
| Poor cut - uneven | <ol style="list-style-type: none"> 1. Worn, bent or loose blade. 2. Mower deck not level. 3. Buildup of grass, leaves, and trash under mower. 4. Bent blade mandrel. 5. Clogged mower deck vent holes from buildup of grass, leaves, and trash around mandrels. | <ol style="list-style-type: none"> 1. Replace blade. Tighten blade bolt. 2. Level mower deck. 3. Clean underside of mower housing. 4. Replace blade mandrel. 5. Clean around mandrels to open vent holes. |
| Mower blades will not rotate | <ol style="list-style-type: none"> 1. Obstruction in clutch mechanism. 2. Worn/damaged mower drive belt. 3. Frozen idler pulley. 4. Frozen blade mandrel. | <ol style="list-style-type: none"> 1. Remove obstruction. 2. Replace mower drive belt. 3. Replace idler pulley. 4. Replace blade mandrel. |
| Poor grass discharge | <ol style="list-style-type: none"> 1. Engine speed too slow. 2. Travel speed too fast. 3. Wet grass. 4. Mower deck not level. 5. Low/uneven tire air pressure. 6. Worn, bent or loose blade. 7. Buildup of grass, leaves and trash under mower. 8. Mower drive belt worn. 9. Blades improperly installed. 10. Improper blades used. 11. Clogged mower deck vent holes from buildup of grass, leaves, and trash around mandrels. | <ol style="list-style-type: none"> 1. Place throttle control in "FAST" position. 2. Shift to slower speed. 3. Allow grass to dry before mowing. 4. Level mower deck. 5. Check tires for proper air pressure. 6. Replace/sharpen blade. Tighten blade bolt. 7. Clean underside of mower housing. 8. Replace mower drive belt. 9. Reinstall blades sharp edge down. 10. Replace with blades listed in this manual. 11. Clean around mandrels to open vent holes. |
| Headlight(s) not working (if so equipped) | <ol style="list-style-type: none"> 1. Switch is "OFF". 2. Bulb(s) or lamp(s) burned out. 3. Faulty light switch. 4. Loose or damaged wiring. 5. Blown fuse. | <ol style="list-style-type: none"> 1. Turn switch "ON". 2. Replace bulb(s) or lamp(s). 3. Check/replace light switch. 4. Check wiring and connections. 5. Replace fuse. |
| Battery will not charge | <ol style="list-style-type: none"> 1. Bad battery cell(s). 2. Poor cable connections. 3. Faulty regulator (if so equipped). 4. Faulty alternator. | <ol style="list-style-type: none"> 1. Replace battery. 2. Check/clean all connections. 3. Replace regulator. 4. Replace alternator. |
| Loss of drive | <ol style="list-style-type: none"> 1. Freewheel control in "disengaged" position. 2. Motion drive belt worn, damaged, or broken. 3. Air trapped in transmission during shipment or servicing. | <ol style="list-style-type: none"> 1. Place freewheel control in "engaged" position. 2. Replace motion drive belt. 3. Purge transmission. |
| Engine "backfires" when turning engine "OFF" | <ol style="list-style-type: none"> 1. Engine throttle control not set at "SLOW" position for 30 seconds before stopping engine. | <ol style="list-style-type: none"> 1. Move throttle control to "SLOW" position and allow to idle for 30 seconds before stopping engine. |

TRACTOR - MODEL NO. YTH2148 (LO21H48F), PRODUCT NO. 954 57 20-35 SCHEMATIC

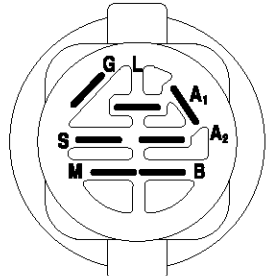
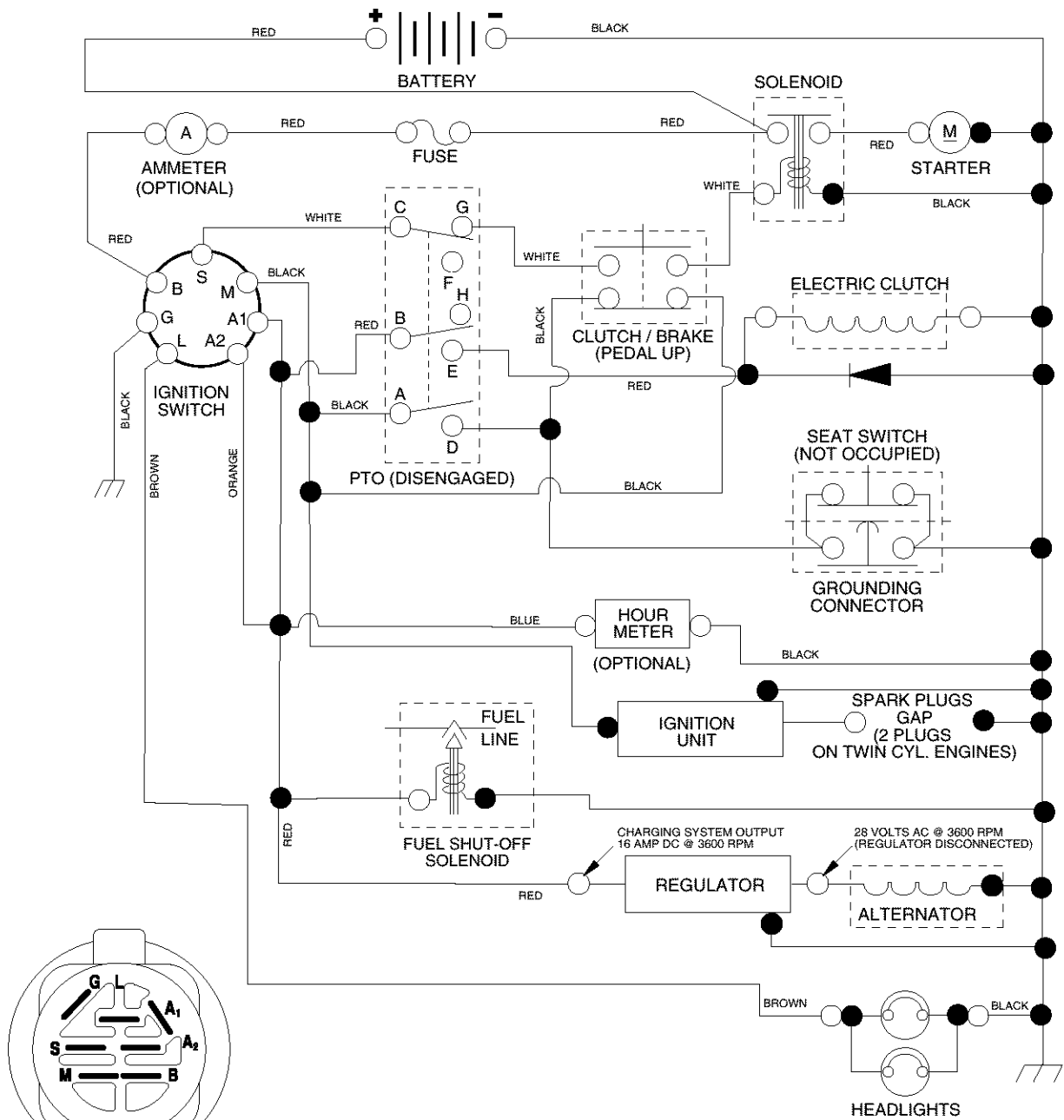

IGNITION SWITCH

| POSITION | CIRCUIT | "MAKE" |
|-------------|------------|--------|
| OFF | M + G + A1 | NONE |
| ON + LIGHTS | B + A1 | L + A2 |
| ON | B + A1 | NONE |
| START | B + S + A1 | NONE |

WIRING INSULATED CLIPS
NOTE: IF WIRING INSULATED CLIPS WERE REMOVED FOR SERVICING OF UNIT, THEY SHOULD BE REPLACED TO PROPERLY SECURE YOUR WIRING.

02757

PTO SWITCH

| POSITION | CIRCUIT |
|----------|---------------------|
| OFF | C + G, B + H |
| ON | C + F, B + E, A + D |

○
REMOVABLE CONNECTIONS

●
NON-REMOVABLE CONNECTIONS

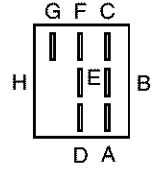

PTO SWITCH CONNECTOR

REPAIR PARTS

TRACTOR - MODEL NO. YTH2148 (LO21H48F), PRODUCT NO. 954 57 20-35
ELECTRICAL

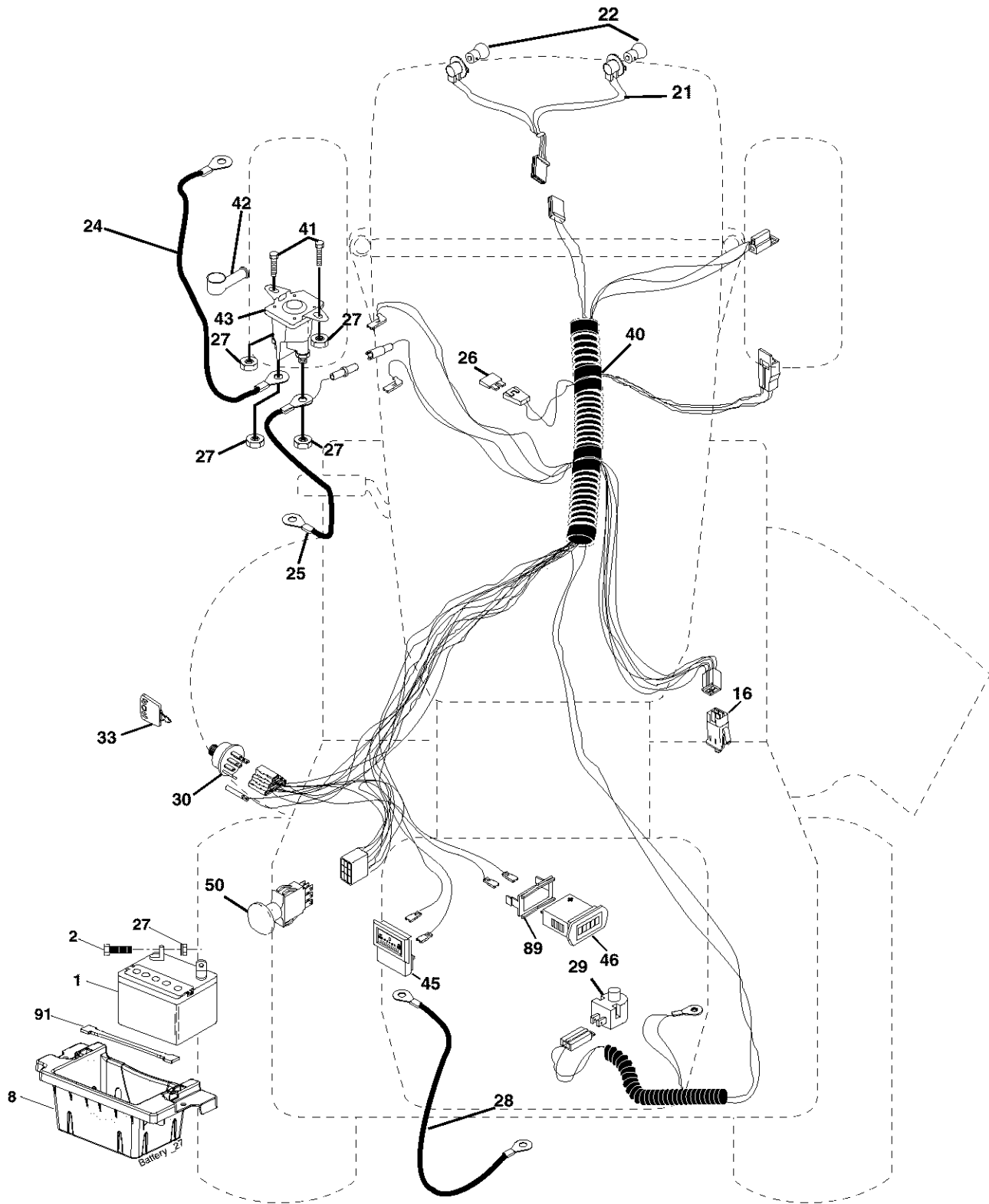

REPAIR PARTS

TRACTOR - MODEL NO. YTH2148 (LO21H48F), PRODUCT NO. 954 57 20-35
ELECTRICAL

| KEY NO. | PART NO. | DESCRIPTION |
|---------|--------------|---------------------------------------|
| 1 | 532 14 49-27 | Battery |
| 2 | 874 76 04-12 | Bolt Hex Hd 1/4-20 unc x 3/4 |
| 8 | 532 18 64-91 | Box Battery |
| 16 | 532 17 61-38 | Switch Interlock Push-In |
| 21 | 532 18 37-59 | Harness Asm Light W/4152j |
| 22 | 532 00 41-52 | Bulb Light #1156 |
| 24 | 532 12 47-80 | Cable Battery 6 Ga. 11" red |
| 25 | 532 14 61-48 | Cable Battery 6 Ga. 22" red w/16 wire |
| 26 | 532 17 51-58 | Fuse 20 AMP |
| 27 | 873 51 04-00 | Nut Keps Hex 1/4-20 unc |
| 28 | 532 14 54-91 | Cable Ground black |
| 29 | 532 12 13-05 | Switch Plunger Nc Gray |
| 30 | 532 18 96-87 | Switch Ign |
| 33 | 532 14 04-01 | Key Ign Molded Generic |
| 40 | 532 18 80-24 | Harness Ign. |
| 41 | 871 11 04-08 | Bolt Blk Fin Hex 1/4 - 20 x 1/2 |
| 42 | 532 13 15-63 | Cover Terminal Red |
| 43 | 532 17 88-61 | Solenoid |
| 45 | 532 12 28-22 | Ammeter |
| 46 | 532 16 96-35 | Hourmeter Snap-In |
| 50 | 532 17 46-51 | Switch PTO |
| 89 | 532 16 96-39 | Bracket Snap-In Hourmeter |
| 90 | 532 18 04-49 | Cover Terminal |
| 91 | 532 19 02-70 | Strap Battery |

NOTE: All component dimensions given in U.S. inches.
1 inch = 25.4 mm.

REPAIR PARTS

TRACTOR - MODEL NO. YTH2148 (LO21H48F), PRODUCT NO. 954 57 20-35
CHASSIS AND ENCLOSURES

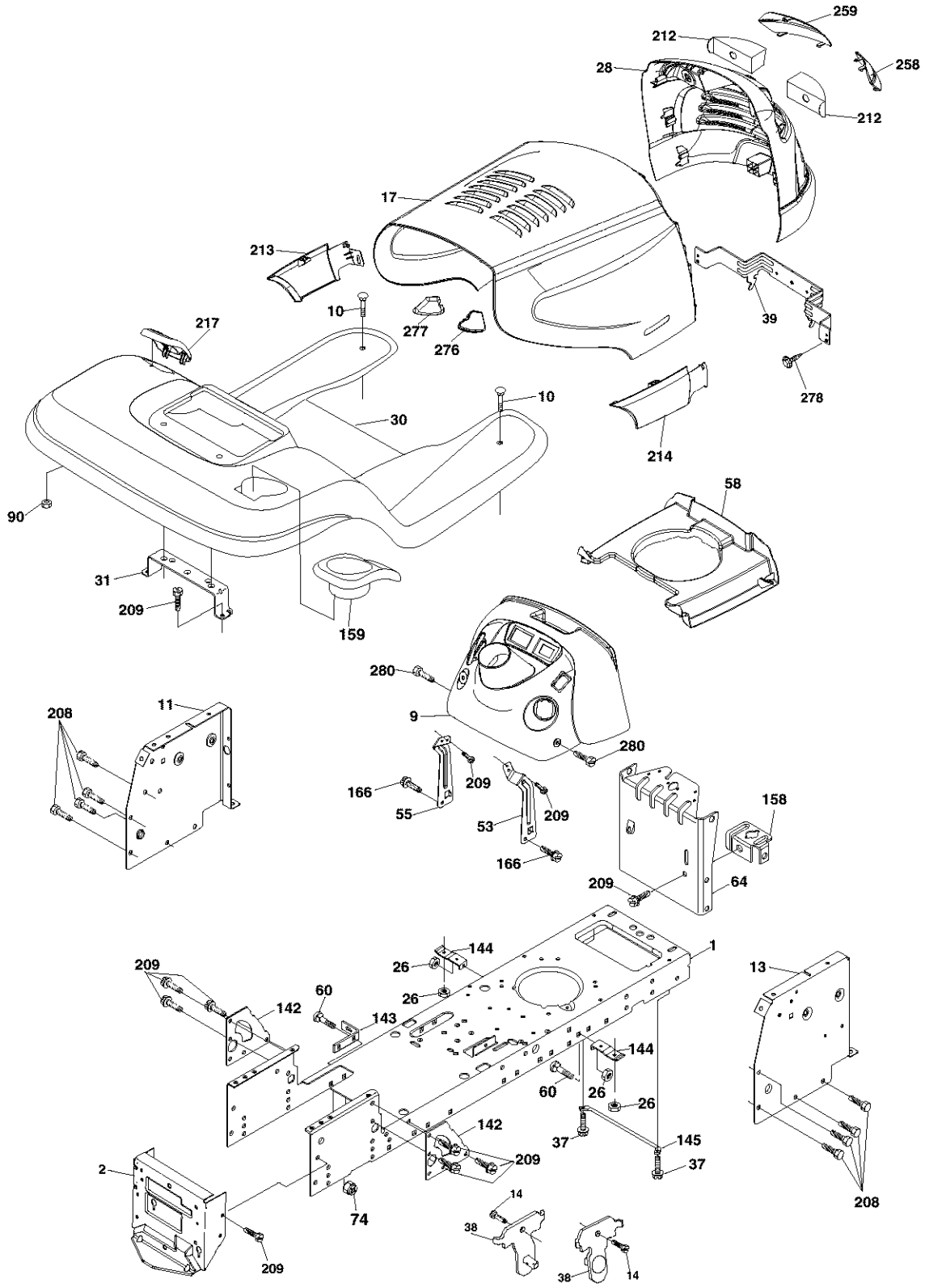

chassis_elite husqy_4

REPAIR PARTS

TRACTOR - MODEL NO. YTH2148 (LO21H48F), PRODUCT NO. 954 57 20-35
CHASSIS AND ENCLOSURES

| KEY NO. | PART NO. | DESCRIPTION |
|---------|--------------|----------------------------------|
| 1 | 532 17 46-19 | Chassis Stamping |
| 2 | 532 17 65-54 | Drawbar |
| 9 | 532 19 00-36 | Dash P/L M |
| 10 | 872 14 06-08 | Bolt Carriage 3/8-16 x 1 |
| 11 | 532 17 49-96 | Panel Dash Lh |
| 13 | 532 18 17-19 | Panel Dash Rh |
| 14 | 817 49 06-08 | Screw Thdrol 3/8-16 x 1/2 |
| 17 | 532 18 99-77 | Hood |
| 26 | 873 80 06-00 | Nut Lock Hex W/Ins 3/8-16 unc |
| 28 | 532 18 82-69 | Grille/Lens Asm. |
| 30 | 532 19 18-15 | Fender Footrest STLT Pnt |
| 31 | 532 13 99-76 | Bracket Support Fender |
| 37 | 817 49 05-08 | Screw Thdrol 5/16-18 x 1/2 TYT |
| 38 | 532 17 57-10 | Bracket Asm Pivot Mower Rear |
| 39 | 532 17 47-14 | Bracket Pivot |
| 53 | 532 18 83-72 | Bracket Dash RH |
| 55 | 532 18 83-73 | Bracket Dash LH |
| 58 | 532 18 93-52 | Air Duct Engine |
| 60 | 872 14 06-06 | Bolt Rdhd Sqnk 3/8-16 unc x 3/4 |
| 64 | 532 17 49-97 | Dash Lower STLT |
| 74 | 873 68 06-00 | Nut Crownlock 3/8-16 unc |
| 90 | 532 12 43-46 | Nut Self-thd Wsh-Hd 1/4 |
| 142 | 532 17 57-02 | Plate Reinforcement STLT |
| 143 | 532 18 66-89 | Bracket Swaybar Chassis |
| 144 | 532 17 55-82 | Bracket Pnt Footrest STLT |
| 145 | 532 15 65-24 | Rod Pivot Chassis/Hood |
| 166 | 532 17 18-75 | Screw HWHD Hi-Lo #13-16 x 3/4 |
| 158 | 532 16 20-37 | Bracket Parking Brake |
| 159 | 532 18 54-34 | Cupholder |
| 208 | 817 67 06-08 | Screw Thdrol 3/8-16 x 1/2 TYT Bl |
| 209 | 817 00 06-12 | Screw 3/8-16 x 3/4 |
| 212 | 532 18 82-67 | Insert Lens Reflect |
| 213 | 532 18 99-79 | Skirt Side LH |
| 214 | 532 18 99-78 | Skirt Side RH |
| 217 | 532 18 54-36 | Console Fuel Window |
| 258 | 532 18 99-81 | Lens RH |
| 259 | 532 18 99-82 | Lens LH |
| 276 | 532 18 92-74 | Bumper Hood RH |
| 277 | 532 18 92-75 | Bumper Hood LH |
| 278 | 532 19 16-11 | Screw 10 x 3/4 Single Lead Hex |
| 280 | 817 00 06-16 | Screw 3/18-16 x 1 |

NOTE: All component dimensions given in U.S. inches
1 inch = 25.4 mm

REPAIR PARTS

TRACTOR - MODEL NO. YTH2148 (LO21H48F), PRODUCT NO. 954 57 20-35
DRIVE

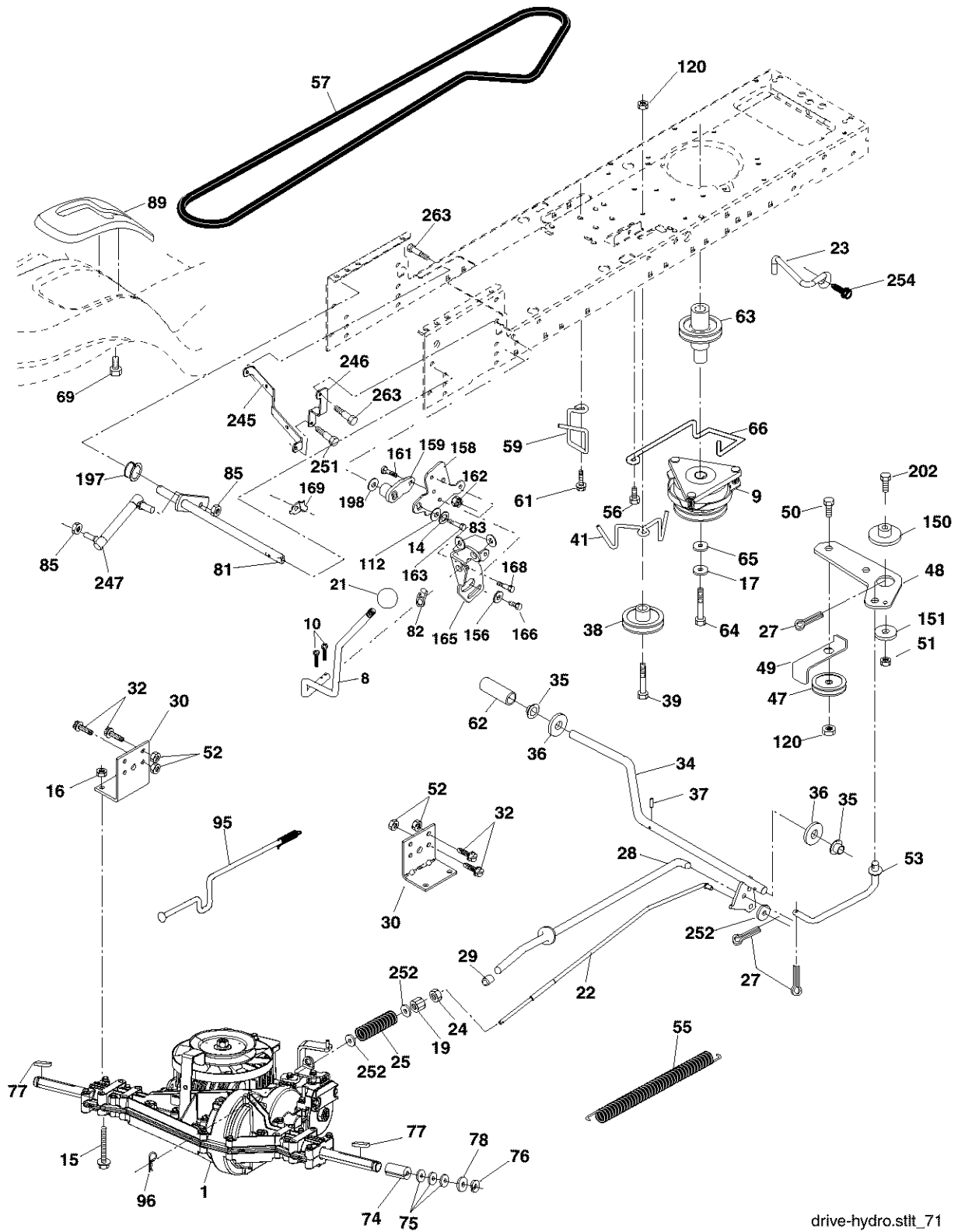

drive-hydro.stilt_71

REPAIR PARTS

TRACTOR - MODEL NO. YTH2148 (LO21H48F), PRODUCT NO. 954 57 20-35 DRIVE

| KEY NO. | PART NO. | DESCRIPTION | KEY NO. | PART NO. | DESCRIPTION |
|---------|--------------|---|---------|--------------|----------------------------------|
| 1 | ----- | Transaxle Peerless LTH2000 (Order parts from transaxle manufacturer) | 64 | 532 17 39-37 | Bolt Hex 7/16-20 x 4 Gr. 5 |
| 8 | 532 16 58-66 | Rod Shift Fender Adjust | 65 | 810 04 06-00 | Washer |
| 9 | 532 17 93-34 | Clutch Ogura | 66 | 532 15 47-78 | Keeper Belt Engine Hydro |
| 10 | 876 02 04-16 | Pin Cotter 1/8 x 1 CAD | 69 | 532 14 24-32 | Screw Hex Wsh Hi-Lo 1/4-1/2 unc |
| 14 | 810 04 04-00 | Washer Lock Hvy Helical | 74 | 532 13 70-57 | Spacer |
| 15 | 874 49 05-44 | Bolt Hex FLGHD 5/16-18 Gr.5 | 75 | 532 12 17-49 | Washer 25/32 x 1-1/4 x 16 Ga. |
| 16 | 873 80 05-00 | Nut Lock Hex W/Ins. 5/16-18 unc | 76 | 812 00 00-01 | E-Ring |
| 17 | 532 12 61-97 | Washer 1-1/2 OD x 15/32 ID x .250 | 77 | 532 12 35-83 | Key, Square |
| 19 | 873 80 06-00 | Nut Lock Hex W/Wsh 3/8-16 unc | 78 | 532 12 17-48 | Washer 25/32 x 1-5/8 x 16 Ga. |
| 21 | 532 14 08-45 | Knob 1/2-13 | 81 | 532 17 81-39 | Shaft Asm Cross Tapered |
| 22 | 532 17 81-41 | Rod, Brake | 82 | 532 16 57-11 | Spring Torsion |
| 23 | 532 19 07-36 | Bracket Anti-Rotation | 83 | 819 17 12-16 | Washer 17/32 x 3/4 x 16 Ga. |
| 24 | 873 35 06-00 | Nut, Hex Jam 3/8-16 unc | 85 | 532 15 03-60 | Nut Lock Center 1/4-28 FNTHD |
| 25 | 532 10 68-88 | Spring, Brake Rod | 89 | 532 19 18-16 | Console, Shift |
| 27 | 876 02 04-12 | Pin Cotter 1/8 x 3/4 CAD. | 95 | 532 17 81-34 | Disconnect Asm Rod Bypas LTH |
| 28 | 532 17 57-65 | Rod, Parking Brake | 96 | 532 12 47-88 | Retainer Spring 1" Zinc/Cad |
| 29 | 532 07 16-73 | Cap, Parking Brake | 112 | 819 09 12-10 | Washer 9/32 x 3/4 x 10 Ga. |
| 30 | 532 16 95-92 | Bracket, Transaxle | 120 | 873 90 06-00 | Nut Lock Flg 3/8-16 |
| 32 | 874 76 05-12 | Bolt Hex Hd 5/16-18 unc x 3/4 | 150 | 532 17 54-56 | Spacer Retainer |
| 34 | 532 17 55-78 | Shaft, Foot Pedal | 151 | 819 13 32-10 | Washer 13/32 x 2 x 10 Ga. |
| 35 | 532 12 01-83 | Bearing, Nylon | 156 | 532 16 60-02 | Washer Srrted 5/16 ID x 1.125 |
| 36 | 819 21 16-16 | Washer | 158 | 532 16 55-89 | Bracket Shift Mount |
| 37 | 532 12 49-63 | Pin, Roll | 159 | 532 18 39-00 | Hub Shift |
| 38 | 532 17 91-14 | Pulley, Composite | 161 | 872 14 04-06 | Bolt Rdhd Sqnk 1/4-20 x 3/4 Gr 5 |
| 39 | 872 11 06-22 | Bolt RDHD 3/8-16 unc x 2 3/4 Gr. 5 | 162 | 873 68 04-00 | Nut Crownlock 1/4-20 unc |
| 41 | 532 17 55-56 | Keeper, Belt Idler | 163 | 874 78 04-16 | Bolt Hex Fin 1/4-20 unc x 1 Gr 5 |
| 47 | 532 12 77-83 | Pulley, Idler, V-Groove | 165 | 532 16 56-23 | Bracket Pivot Lever |
| 48 | 532 15 44-07 | Bellcrank, Clutch | 166 | 817 49 05-10 | Screw 5/16-18 x 5/8 |
| 49 | 532 12 32-05 | Retainer, Belt | 168 | 532 16 54-92 | Bolt Shoulder 5/16-18 x .561 |
| 50 | 872 11 06-12 | Bolt Carr Sh 3/8-16 x 1-1/2 Gr 5 | 169 | 532 16 55-80 | Plate Fastening |
| 51 | 873 68 06-00 | Nut Crownlock 3/8-16 unc | 197 | 532 16 96-13 | Nyliner Snap-In 5/8"ID |
| 52 | 873 68 05-00 | Nut, Crownlock 5/16-18 unc | 198 | 532 16 95-93 | Washer Nyl 7/8 ID x .105" Hyd |
| 53 | 532 10 57-10 | Link, Clutch | 202 | 872 11 06-14 | Bolt Carr Sh 3/8-16 x 1-3/4 Gr.5 |
| 55 | 532 10 57-09 | Spring, Return, Clutch | 245 | 532 17 81-22 | Strap Torque Lh LTH2000 |
| 56 | 817 06 06-20 | Screw 3/8-16 x 1-1/4 | 246 | 532 17 81-21 | Strap Torque Rh LTH2000 |
| 57 | 532 17 81-38 | V-Belt | 247 | 532 18 14-62 | Link Shift Transaxle LTH2000 |
| 59 | 532 16 96-91 | Keeper, Center Span | 251 | 817 06 05-16 | Screw 5/16-18 x 1 |
| 61 | 817 12 06-14 | Screw 3/8-16 x .875 | 252 | 819 13 16-16 | Washer 13/32 x 1 x 16 Ga. |
| 62 | 532 12 48-72 | Cover, Pedal | 254 | 817 00 06-16 | Screw 3/8-16 x 1 |
| 63 | 532 17 46-07 | Pulley, Engine | 263 | 817 00 06-12 | Screw Hex Wsh Thdr 3/8-16 x 3/4 |

NOTE:All component dimensions give in U.S. inches.
1 inch = 25.4 mm.

REPAIR PARTS

TRACTOR - MODEL NO. YTH2148 (LO21H48F), PRODUCT NO. 954 57 20-35
STEERING ASSEMBLY

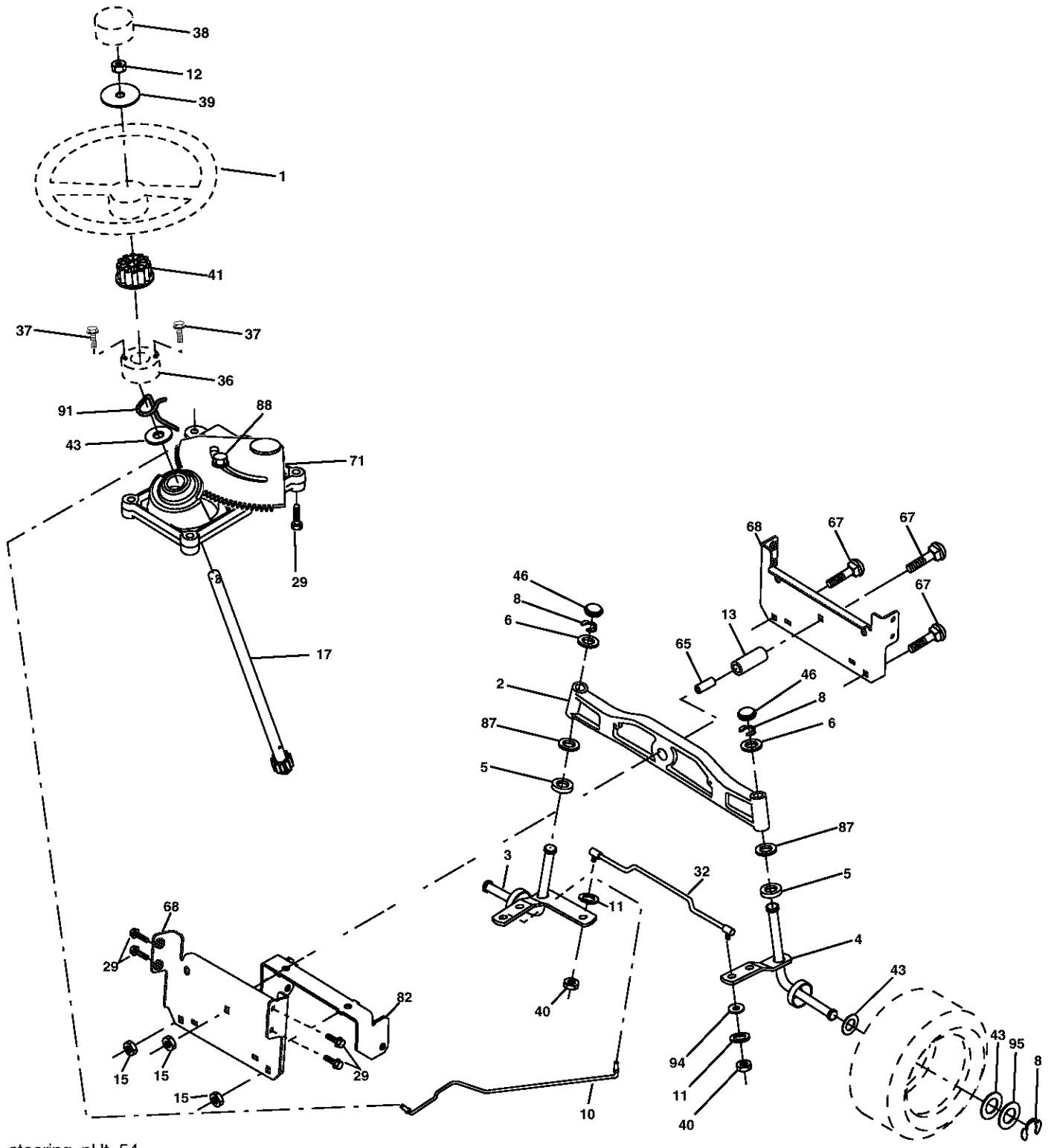

steering_pl.it_54

REPAIR PARTS

TRACTOR - MODEL NO. YTH2148 (LO21H48F), PRODUCT NO. 954 57 20-35
STEERING ASSEMBLY

| KEY NO. | PART NO. | DESCRIPTION |
|---------|--------------|--------------------------------|
| 1 | 532 16 66-27 | Wheel Steering |
| 2 | 532 18 47-06 | Axle |
| 3 | 532 16 98-40 | Spindle Asm LH |
| 4 | 532 16 98-39 | Spindle Asm RH |
| 5 | 532 12 49-31 | Bearing Race Thrust Harden |
| 6 | 532 12 17-48 | Washer 25/32 x 1-5/8 x 16 Ga. |
| 8 | 812 00 00-29 | Ring Klip #t5304-75 |
| 10 | 532 17 51-21 | Link Drag |
| 11 | 810 04 06-00 | Washer Lock Hvy Hlcl Spr 3/8 |
| 12 | 873 94 08-00 | Nut Hex Jam Toplock 1/2-20 unf |
| 13 | 532 13 65-18 | Spacer Brg Axle Front |
| 15 | 532 14 52-12 | Nut Hex Flange Lock |
| 17 | 532 17 78-83 | Shaft Asm Strg |
| 29 | 817 00 06-12 | Screw 3/8-16 x 3/4 |
| 32 | 532 18 05-80 | Rod Tie |
| 34 | 810 04 05-00 | Washer Lock Hvy Helical 5/16 |
| 36 | 532 15 51-05 | Bushing Strg |
| 37 | 532 15 29-27 | Screw |
| 38 | 532 16 66-26 | Insert Cap Strg Wh |
| 39 | 819 18 38-12 | Washer 9/16 x 2-3/8 12 Ga. |
| 40 | 873 54 06-00 | Nut Crownlock 3/8-24 |
| 41 | 532 15 99-45 | Adaptor Wheel Strg |
| 43 | 532 12 17-49 | Washer 25/32 x 1 1/4 x 16 Ga. |
| 46 | 532 12 12-32 | Cap Spindle Fr Top Blk |
| 65 | 532 16 03-67 | Spacer Brace Axle |
| 67 | 872 11 06-18 | Bolt Rdhd Sq 3/8-16 x 2-1/4 |
| 68 | 532 16 98-27 | Axle, Brace |
| 71 | 532 17 51-46 | Steering Asm |
| 82 | 532 16 98-35 | Bracket Susp Chassis Front |
| 87 | 532 17 39-66 | Washer Flat .781 x 1-1/2 x .14 |
| 88 | 532 17 51-18 | Bolt Shoulder 7/16-20 |
| 91 | 532 17 55-53 | Clip Steering |
| 94 | 819 12 14-14 | Washer 3/8 x 7/8 x 14 Ga. |
| 95 | 532 18 89-67 | Washer Hardened |

NOTE: All component dimensions given in U.S. inches.
1 inch = 25.4 mm.

REPAIR PARTS

TRACTOR - MODEL NO. YTH2148 (LO21H48F), PRODUCT NO. 954 57 20-35
SEAT ASSEMBLY

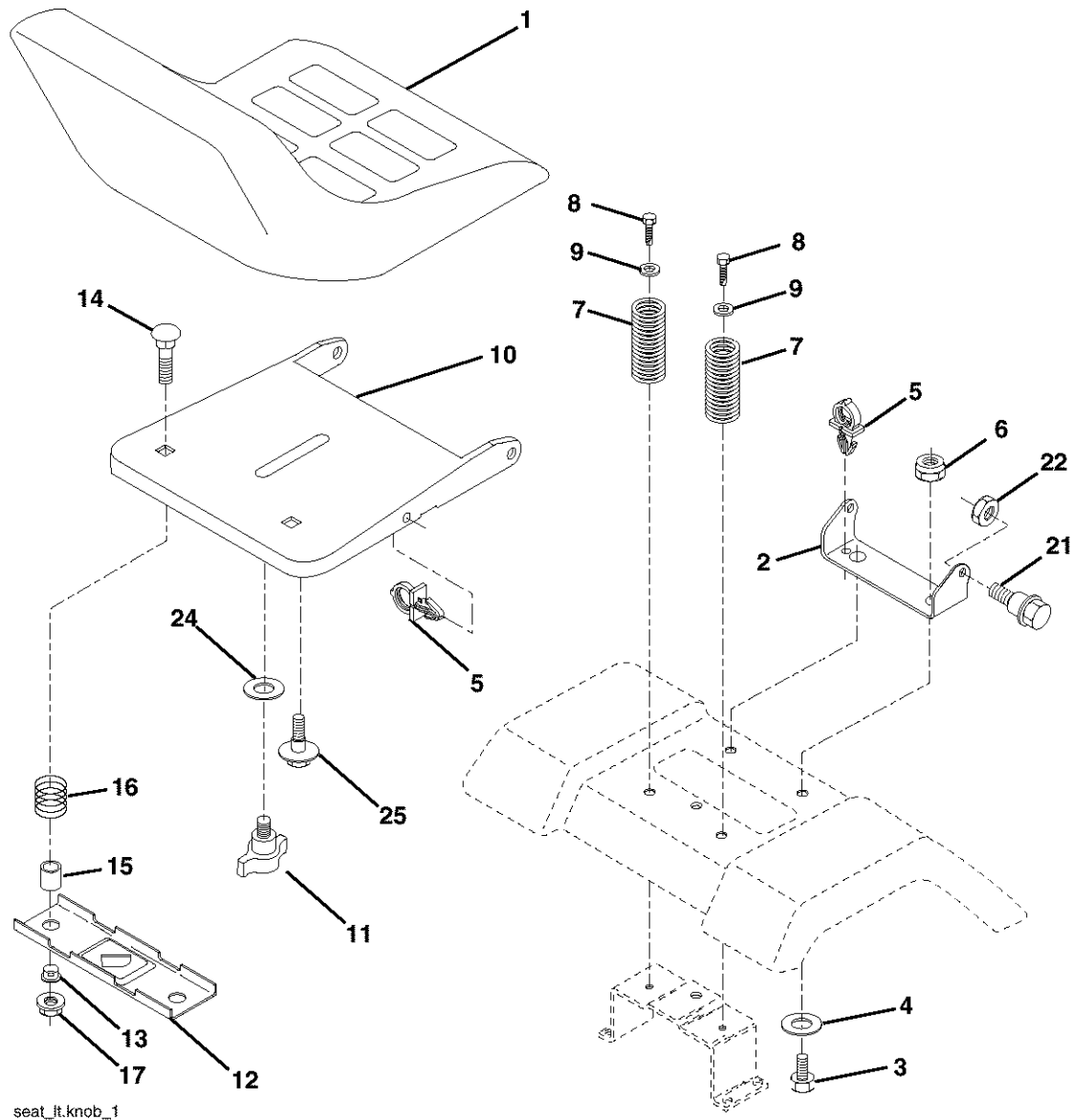

seat_ft.knob_1

| KEY NO. | PART NO. | DESCRIPTION |
|---------|--------------|------------------------------------|
| 1 | 532 18 87-15 | Seat |
| 2 | 532 14 05-51 | Bracket Pivot Seat 8 720 |
| 3 | 871 11 06-16 | Bolt Fin Hex 3/8-16 unc x 1 |
| 4 | 819 13 16-10 | Washer 13/32 x 1 x 10 Ga. |
| 5 | 532 14 50-06 | Clip Push-In |
| 6 | 873 80 06-00 | Nut Hex w/Ins. 3/8-16 unc |
| 7 | 532 12 41-81 | Spring Seat Cprsn 2 250 Blk Zi |
| 8 | 817 00 06-16 | Screw 3/8-16 x 1-1/2 Smgml Tap/R Z |
| 9 | 819 13 16-14 | Washer 13/32 x 1 x 14 Ga. |
| 10 | 532 18 24-93 | Pan Seat |
| 11 | 532 16 63-69 | Knob Seat Adj. Wingnut |
| 12 | 532 12 12-46 | Bracket Mounting Switch |
| 13 | 532 12 12-48 | Bushing Snap Blk Nyl 50 Id |

| KEY NO. | PART NO. | DESCRIPTION |
|---------|--------------|-------------------------------------|
| 14 | 872 05 04-12 | Bolt Rdhd Sqnk 1/4-2 x 1-1/2 |
| 15 | 532 12 17-49 | Spacer |
| 16 | 532 12 37-40 | Spring Cprsn |
| 17 | 532 12 39-76 | Nut Lock 1/4 Lge Flg Gr. 5 Zinc |
| 21 | 532 17 18-52 | Bolt Shoulder 5/16-18 unc-2a Blk DA |
| 22 | 873 80 05-00 | Nut Hex Lock W/Ins 5/16-18 |
| 24 | 819 17 19-12 | Washer 17/32 x 13/16 x 12 Ga. |
| 25 | 532 12 70-18 | Bolt Shoulder 5/16-18 x 62 |

NOTE: All component dimensions given in U.S. inches.
1 inch = 25.4 mm

REPAIR PARTS

TRACTOR - MODEL NO. YTH2148 (LO21H48F), PRODUCT NO. 954 57 20-35
DECALS

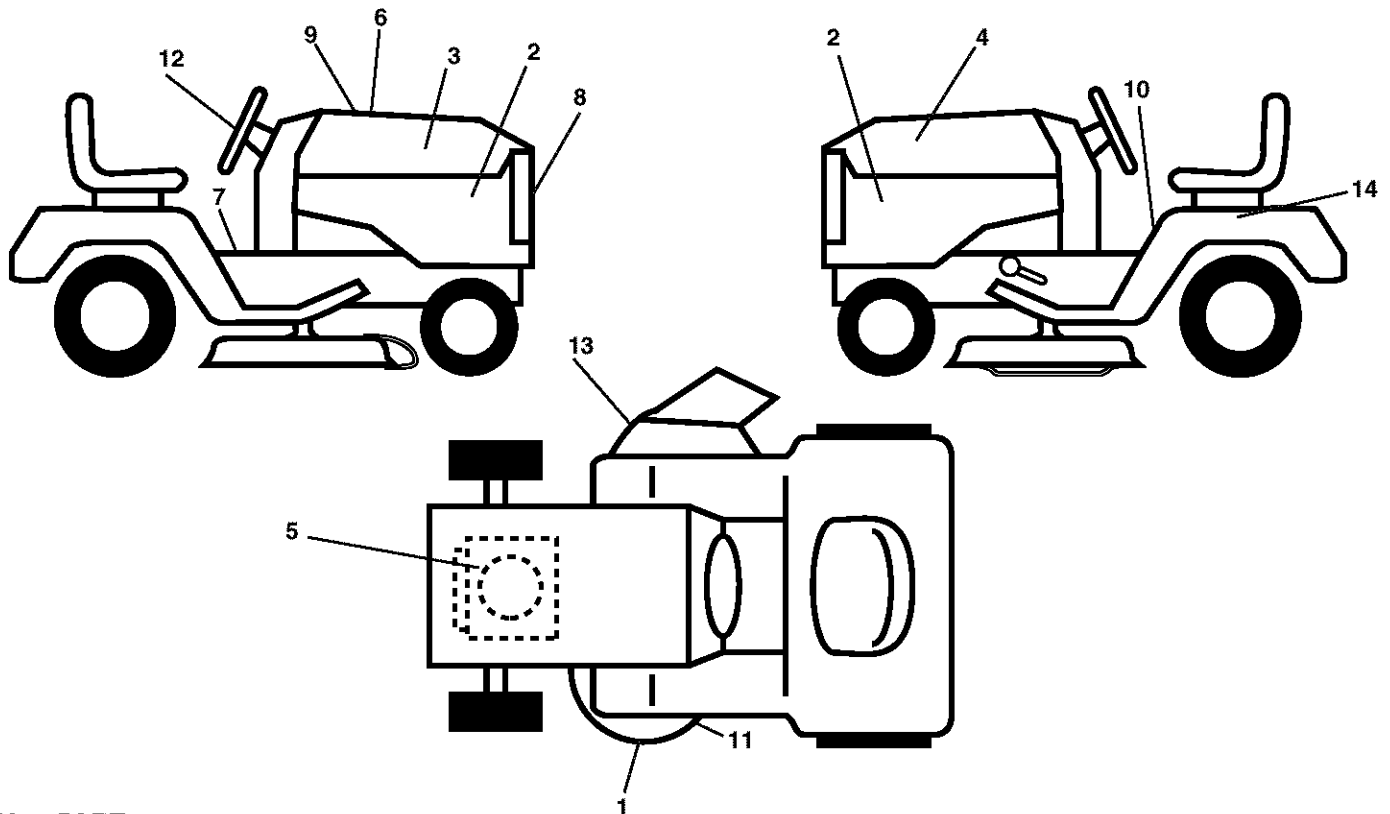

| KEY NO. | PART NO. | DESCRIPTION |
|---------|---------------------|------------------------|
| 1 | 532 17 84-82 | Decal Deck Hvy Duty |
| 2 | 532 19 22-01 | Decal Panel Side |
| 3 | 532 18 89-18 | Decal Hood RH |
| 4 | 532 18 89-19 | Decal Hood LH |
| 6 | 532 18 09-41 | Decal Hood Cust. Resp. |
| 7 | 532 15 70-32 | Decal Operator |
| 8 | 532 18 92-43 | Decal Dash |
| 9 | 532 19 23-23 | Decal Replacement |
| 10 | 532 15 71-40 | Decal Fender Danger |
| 11 | 532 17 52-91 | Decal V-Belt Sch. |

| KEY NO. | PART NO. | DESCRIPTION |
|---------|---------------------|--------------------------------|
| 12 | 532 18 89-25 | Decal Wheel Steering |
| 13 | 532 17 05-63 | Decal Warning |
| 14 | 532 14 50-05 | Decal Bat Dan/Psn |
| -- | 532 17 83-92 | Decal Chass. Disconnect |
| -- | 532 18 82-52 | Pad Footrest LH STLT |
| -- | 532 18 82-53 | Pad Footrest RH STLT |
| -- | 532 13 83-11 | Decal Handle Lft Height Adjust |
| -- | 532 19 23-31 | Manual Operator's (English) |

WHEELS & TIRES

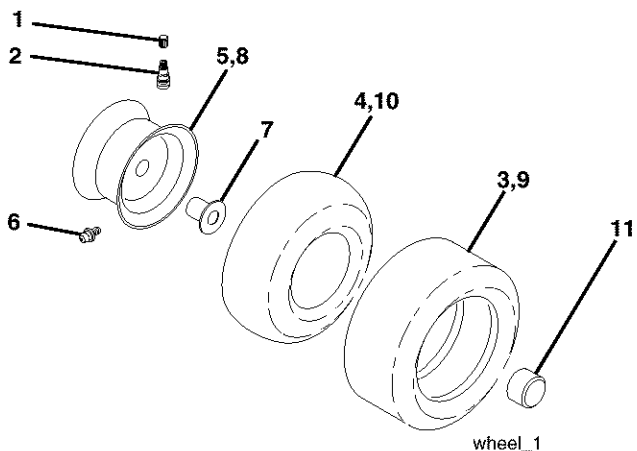

| KEY NO. | PART NO. | DESCRIPTION |
|---------|--------------|-----------------------------------|
| 1 | 532 05 91-92 | Cap Valve Tire |
| 2 | 532 06 51-39 | Stem Valve |
| 3 | 532 10 62-22 | Tire F Ts 15 x 6 0 - 6 Service |
| 4 | 532 05 99-04 | Tube Front (Service Item Only) |
| 5 | 532 13 83-36 | Rim Asm 6"front Silver Service |
| 6 | 532 12 49-57 | Fitting Grease (Front Wheel Only) |
| 7 | 532 12 49-59 | Bearing Flange (Front Wheel Only) |
| 8 | 532 13 83-37 | Rim Asm 8"rear Silver Service |
| 9 | 532 12 20-82 | Tire R Ts 20 x 10-8 C Service |
| 10 | 532 12 49-26 | Tube Rear (Service Item Only) |
| 11 | 532 17 50-39 | Cap Axle Blk 1 50 x 1 00 |
| -- | 532 14 43-34 | Sealant, Tire (10 oz. Tube) |

NOTE: All component dimensions given in U.S. inches
1 inch = 25.4 mm

REPAIR PARTS

TRACTOR - MODEL NO. YTH2148 (LO21H48F), PRODUCT NO. 954 57 20-35
ENGINE

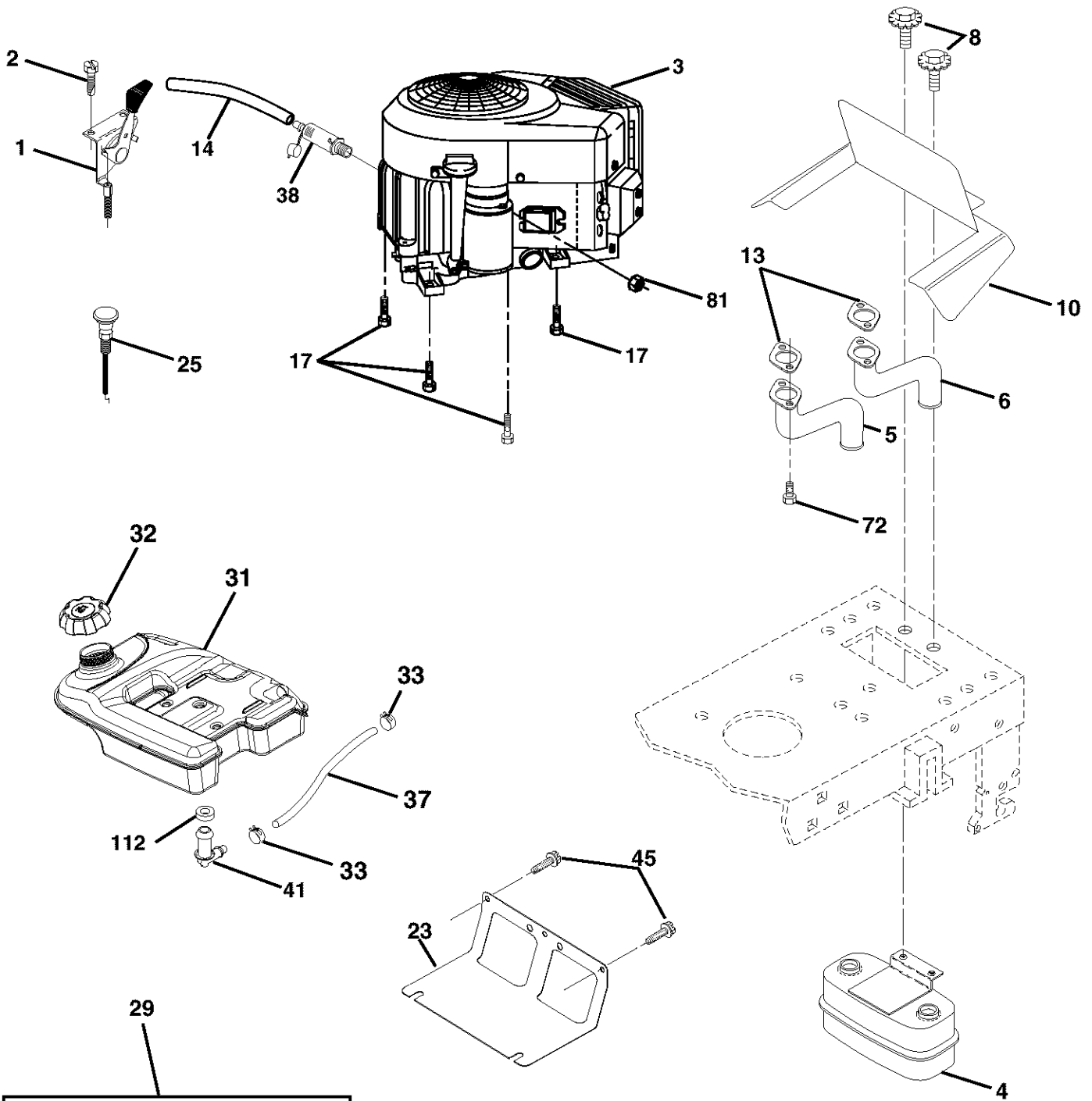

OPTIONAL EQUIPMENT
Spark Arrester

engine-bs.twin_43

REPAIR PARTS

TRACTOR - MODEL NO. YTH2148 (LO21H48F), PRODUCT NO. 954 57 20-35
ENGINE

| KEY NO. | PART NO. | DESCRIPTION |
|---------|--------------|---|
| 1 | 532 17 08-03 | Control Th/ch Flag |
| 2 | 817 72 04-08 | Screw Hex Thd Cut 1/4-20 x 1/2 |
| 3 | ----- | Engine Briggs 385777 (Order Parts From Engine Manufacturer) |
| 4 | 532 14 97-23 | Muffler |
| 5 | 532 19 15-48 | Exhaust Tube LH |
| 6 | 532 19 15-49 | Exhaust Tube RH |
| 8 | 532 17 18-77 | Bolt 5/16-18 unc x 3/4 |
| 10 | 532 16 27-97 | Shield Heat Muffler |
| 13 | 532 16 53-91 | Gasket |
| 14 | 532 14 84-56 | Tube Drain Oil Easy |
| 17 | 817 06 06-24 | Screw 3/8-16 x 1-1/2 |
| 23 | 532 16 98-37 | Shield Browning/Debris Guard |
| 25 | 532 16 17-29 | Control Choke |
| 26 | 873 92 06-00 | Nut Keps 3/8-24 unf |
| 29 | 532 13 71-80 | Kit Spark Arrestor (Flat Scrn) |
| 31 | 532 17 90-22 | Tank Fuel |
| 32 | 532 18 18-03 | Cap Asm Fuel |
| 33 | 532 12 34-87 | Clamp Hose Black |
| 37 | 532 14 21-58 | Line Fuel |
| 38 | 532 18 16-54 | Plug Drain Oil Easy |
| 41 | 532 13 92-77 | Stem Tank Fuel |
| 45 | 817 00 06-12 | Screw Hex Wsh Thdr 3/8-16 x 3/4 |
| 72 | 532 18 39-06 | Screw Socket Head 5/16-18 x 1 |
| 81 | 873 51 04-00 | Nut Keps Hex 1/4-20 Starter Nut |
| 112 | 532 12 49-52 | Bushing |

NOTE: All component dimensions given in U.S. inches
1 inch = 25.4 mm

For engine service and replacement parts, call the toll free number for your engine manufacturer listed below:

| | |
|-------------------|----------------|
| Briggs & Stratton | 1-800-233-3723 |
| Kohler Co. | 1-800-544-2444 |
| Tecumseh Products | 1-800-558-5402 |
| Honda Engines | 1-800-426-7701 |
| Kawasaki | 1-800-460-5688 |

REPAIR PARTS

TRACTOR - MODEL NO. YTH2148 (LO21H48F), PRODUCT NO. 954 57 20-35
MOWER LIFT

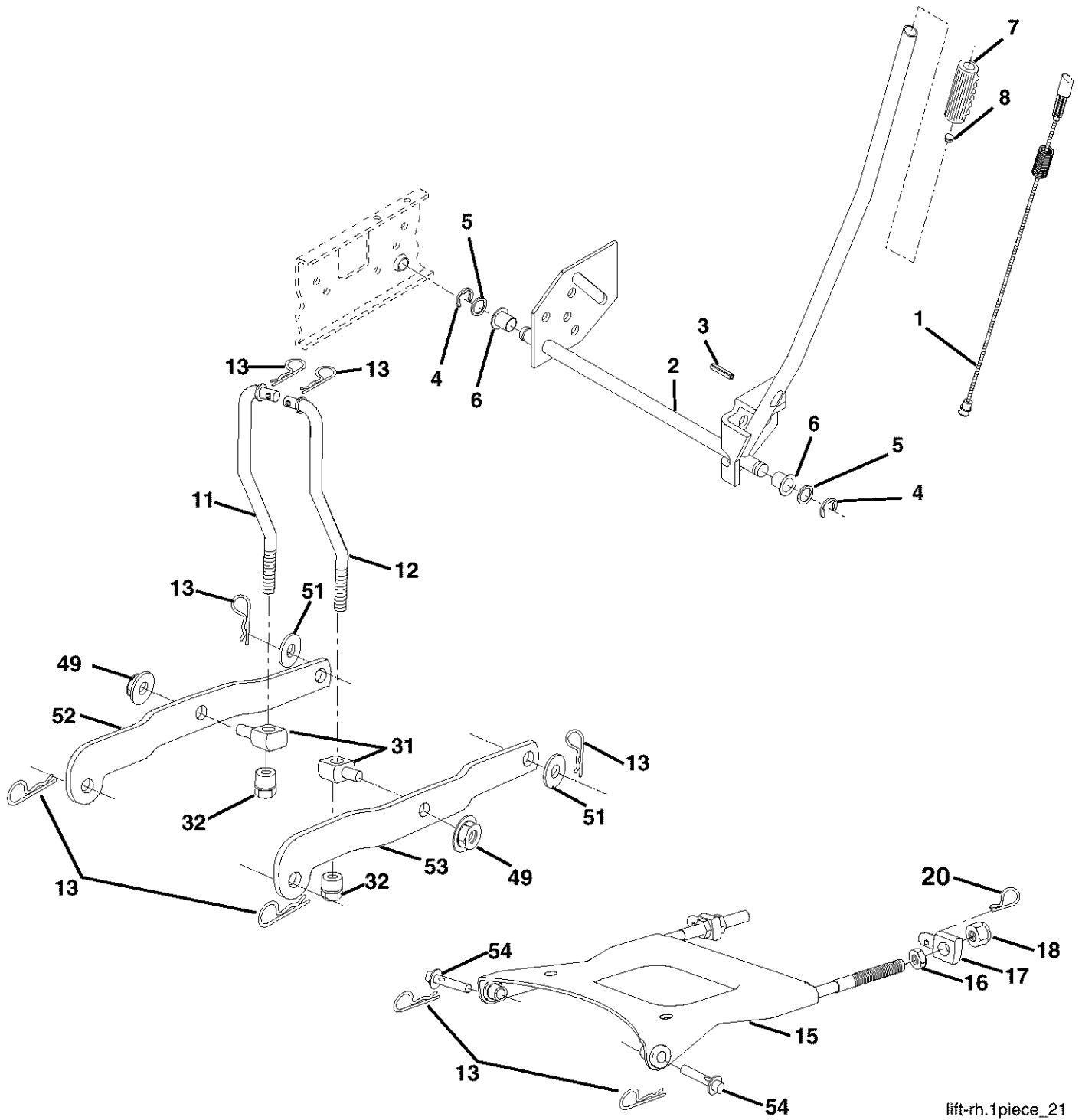

lift-rh.1piece_21

REPAIR PARTS

TRACTOR - MODEL NO. YTH2148 (LO21H48F), PRODUCT NO. 954 57 20-35
MOWER LIFT

| KEY NO. | PART NO. | DESCRIPTION |
|---------|--------------|--------------------------------|
| 1 | 532 15 94-60 | Wire Asm Inner W/plunger 17 32 |
| 2 | 532 15 94-71 | Shaft Asm Lift LH Inf Hgt P/L |
| 3 | 532 10 57-67 | Pin Groove 1 500 Zinc |
| 4 | 812 00 00-02 | E Ring #5133-62 |
| 5 | 819 21 16-21 | Washer 21/32 x 1 x 21 Ga. |
| 6 | 532 12 01-83 | Bearing Nylon Blk 629 Id |
| 7 | 532 12 56-31 | Grip Handle |
| 8 | 532 12 45-26 | Button Plunger |
| 11 | 532 17 53-70 | Link Lift LH |
| 12 | 532 17 53-71 | Link Lift RH |
| 13 | 532 12 46-70 | Retainer Spring |
| 15 | 532 17 55-62 | Plate Asm Suspension Front |
| 16 | 873 35 08-00 | Nut Jam Hex 1/2-13 unc |
| 17 | 532 17 56-89 | Trunnion Blk Zinc |
| 18 | 873 80 08-00 | Nut Lock W/wsh 1/2-13 unc |
| 20 | 532 16 35-52 | Retainer Spring |
| 31 | 532 17 62-05 | Trunnion Suspension Arm |
| 32 | 532 17 59-94 | Nut Lift Link 7/16-20 |
| 49 | 532 14 52-12 | Nut Hex Flange Lock |
| 51 | 819 17 14-16 | Washer 17/32 x 7/8 x 16 Ga. |
| 52 | 532 17 53-78 | Arm Suspension Rear LH |
| 53 | 532 17 58-02 | Arm Suspension Rear RH |
| 54 | 532 17 55-60 | Pin Flange |

NOTE: All component dimensions given in U.S. inches
1 inch = 25.4 mm

REPAIR PARTS

TRACTOR - MODEL NO. YTH2148 (LO21H48F), PRODUCT NO. 954 57 20-35
MOWER DECK

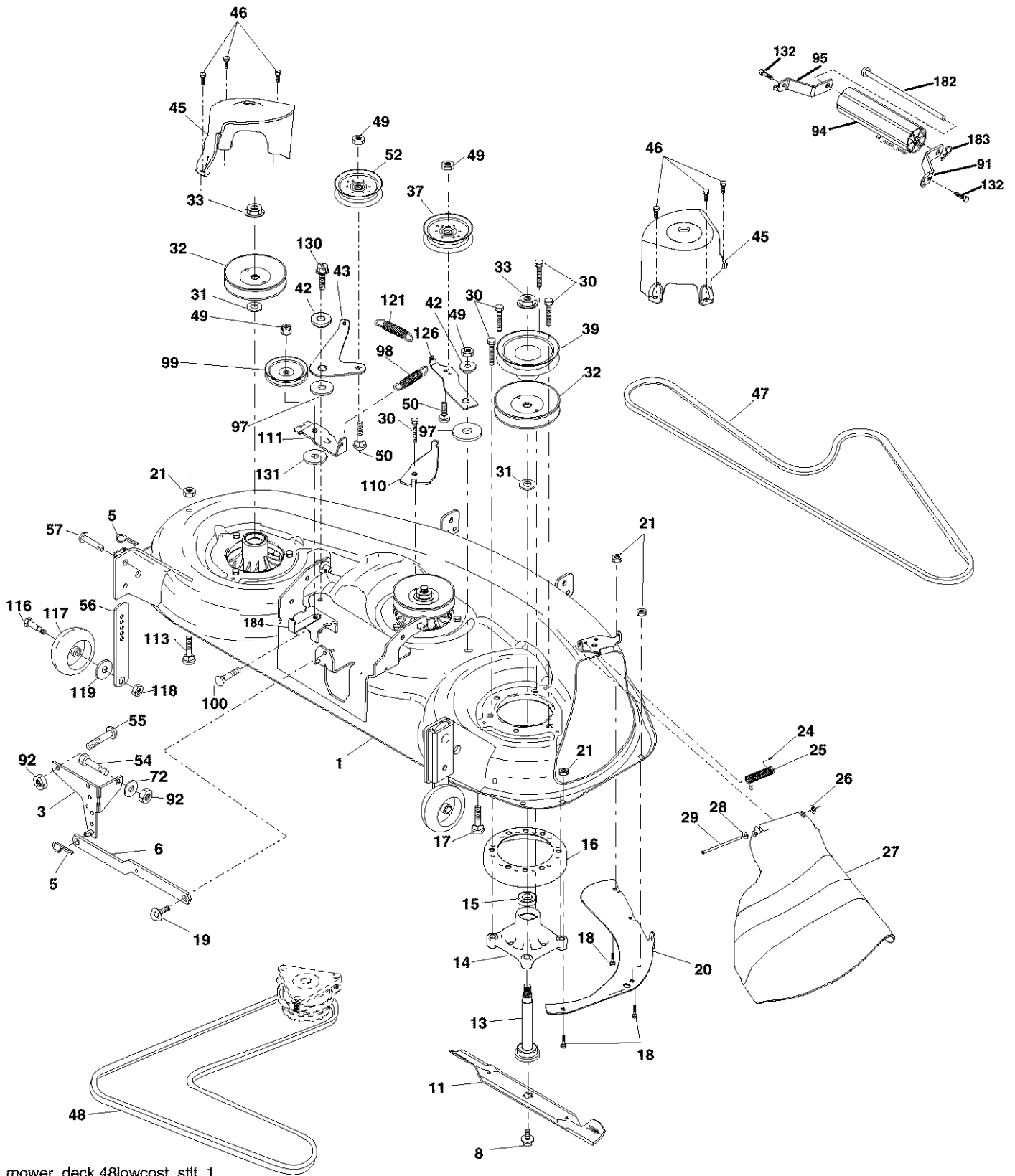

mower_deck.48lowcost_stlt_1

REPAIR PARTS

TRACTOR - MODEL NO. YTH2148 (LO21H48F), PRODUCT NO. 954 57 20-35 MOWER DECK

| KEY NO. | PART NO. | DESCRIPTION | KEY NO. | PART NO. | DESCRIPTION |
|---------|--------------|-------------------------------------|---------|--------------|--|
| 1 | 532 18 33-89 | Deck Weldment Mower 48 | 54 | 874 78 06-16 | Bolt Fin Hex 3/8-16 x 1 |
| 3 | 532 13 80-17 | Bracket Asm., Sway Bar | 55 | 872 14 06-08 | Bolt Rdhd Sqnk 3/8-16 x 1 |
| 5 | 532 12 46-70 | Retainer Spring | 56 | 532 15 59-86 | Bar Pnt Adjusting Wheel Gauge |
| 6 | 532 17 80-24 | Bar Sway Deck | 57 | 532 15 69-41 | Pin Head Rivet |
| 8 | 532 17 43-65 | Bolt, 7/16 Asm. Blade | 72 | 819 13 13-12 | Washer 13/32 x 13/16 x 12 |
| 11 | 532 18 00-54 | Blade | 91 | 532 18 05-35 | Bracket, Asm Noseroller, RH 48 |
| 13 | 532 17 51-47 | Shaft Asm. Mandrel Sealed | 92 | 873 80 06-00 | Nut Lock Hex w/Ins 3/8-16 |
| 14 | 532 17 43-58 | Housing Mandrel 48" | 94 | 532 17 60-66 | Roller, Nose 48" |
| 15 | 532 11 04-85 | Bearing, Ball, Mandrel | 95 | 532 18 05-34 | Bracket, Asm Noseroller LH 48 |
| 16 | 532 17 44-93 | Stripper, Mower | 97 | 532 17 85-15 | Washer Hardened |
| 17 | 872 11 06-10 | Bolt Rdhd Sq Neck 3/8-16 x 1.25 | 98 | 532 17 94-79 | Spring Primary Drive |
| 18 | 872 14 05-05 | Bolt, Carriage 5/16-18 x 5/8 | 99 | 532 18 40-58 | Pulley Idler "V" |
| 19 | 532 13 28-27 | Bolt, Hex Head, Shoulder 5/16-18 | 100 | 872 11 06-16 | Bolt RDHD Sqnk 3/8-16 unc x 2 |
| 20 | 532 17 43-78 | Baffle, Vortex Mower | 110 | 532 17 50-16 | Arm Spring Secondary |
| 21 | 873 68 05-00 | Nut, Crownlock 5/16-18 unc | 111 | 532 17 46-10 | Arm Spring Fixed Tension |
| 24 | 532 10 53-04 | Cap, Sleeve | 113 | 872 11 05-06 | Bolt Rdhd Sqnk 5/16-18 unc x 3/4 |
| 25 | 532 17 81-02 | Spring, Torsion | 116 | 532 18 42-19 | Bolt, Shoulder |
| 26 | 532 11 04-52 | Nut, Push | 117 | 532 13 39-57 | Gauge Wheel |
| 27 | 532 18 17-07 | Shield, Deflector Mower | 118 | 873 93 06-00 | Nut, Centerlock 3/8-16 unc |
| 28 | 819 11 10-16 | Washer 11/32 x 5/8 x 16 Ga. | 119 | 819 12 14-14 | Washer 3/8 x 7/8 x 14 Ga. |
| 29 | 532 13 14-91 | Rod, Hinge | 121 | 532 17 43-71 | Spring Secondary Drive |
| 30 | 532 17 39-84 | Screw, Thdroll, Washer Head | 126 | 532 17 43-72 | Arm, Idler, Primary Deck |
| 31 | 532 18 76-90 | Washer, Spacer Mower Vented | 130 | 817 00 06-16 | Screw 3/8-16 x 1.0 |
| 32 | 532 17 34-36 | Pulley, Mandrel | 131 | 819 13 16-06 | Washer 13/32 x 1 x 6 Ga. |
| 33 | 532 17 83-42 | Nut, Fig. Top Lock Cntr. 9/16 | 132 | 817 00 06-12 | Screw 3/8-16 x 3/4 |
| 36 | 819 13 13-16 | Washer 13/32 x 13/16 x 16 Ga. | 182 | 532 17 91-27 | Rod Roller Nose |
| 37 | 532 17 79-68 | Pulley, Idler, Flat | 183 | 532 16 35-52 | Retainer Spring |
| 39 | 532 17 43-75 | Pulley, Idler, Driven | 184 | 532 17 39-79 | Keeper Belt Idler |
| 42 | 532 12 20-52 | Spacer, Retainer | -- | 532 17 43-57 | Mandrel Assembly (Includes Housing, Shaft and Shaft Hardware Only-Pulley Not Included) |
| 43 | 532 17 43-73 | Arm, Idler Secondary | -- | 532 18 99-06 | Replacement Mower, Complete (Std Deck-Order Separately Nose Roller Components Key Nos. 91, 94, 95, 132, 182-183) |
| 45 | 532 18 08-06 | Cover, Mandrel Deck | | | |
| 46 | 532 13 77-29 | Screw, Thdroll. 1/4-20 x 5/8 | | | |
| 47 | 532 18 08-08 | V-Belt, Mower, Secondary | | | |
| 48 | 532 17 43-68 | V-Belt, Mower, Primary | | | |
| 49 | 839 00 06-00 | Nut, Lock 3/8-16 unc | | | |
| 50 | 872 11 06-12 | Bolt, Carriage 3/8-16 x 1-1/2 Gr. 5 | | | |
| 52 | 532 17 58-20 | Pulley Idler Flat 46 Pri. Drive | | | |

NOTE: All component dimensions given in U.S. inches
1 inch = 25.4 mm

SUGGESTED GUIDE FOR SIGHTING SLOPES FOR SAFE OPERATION

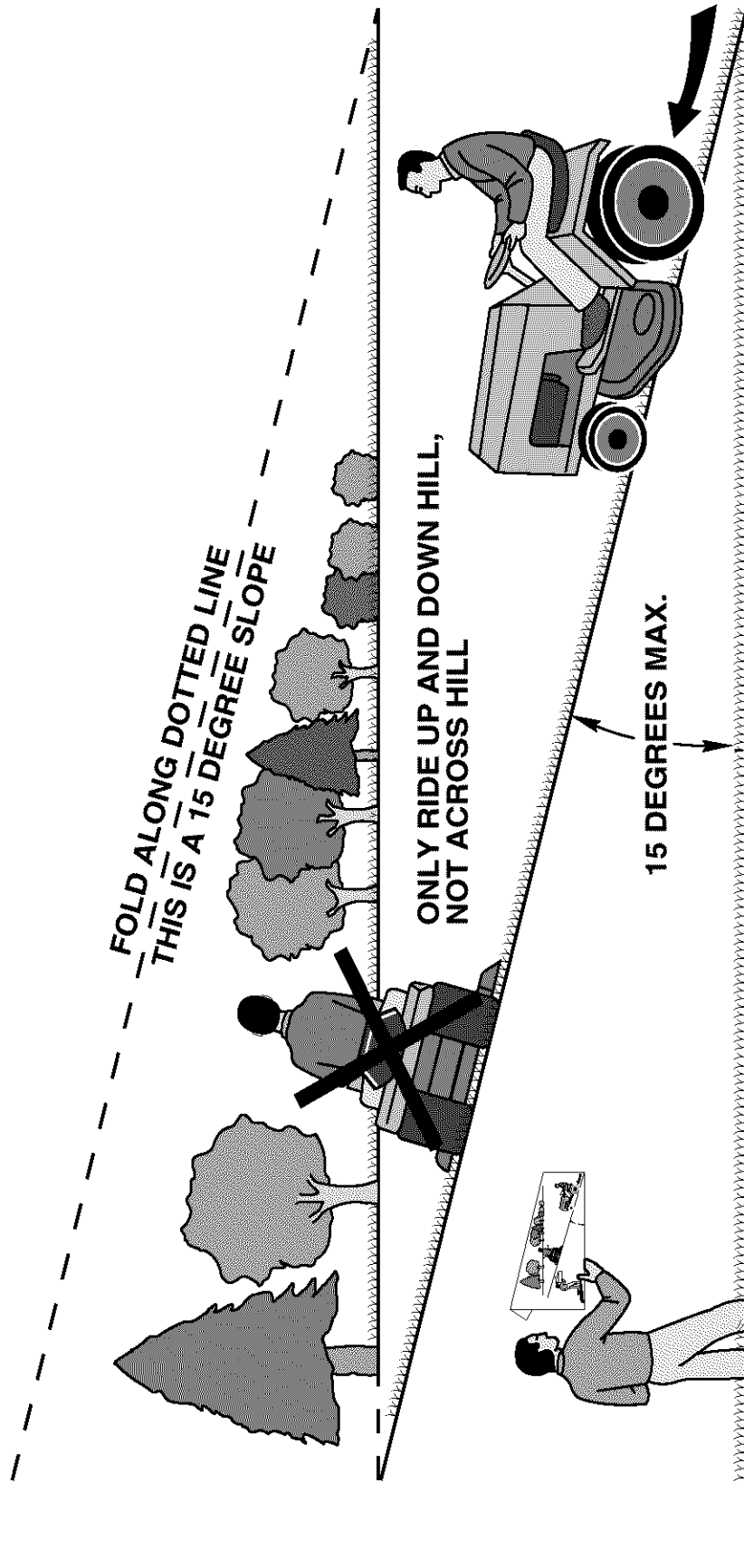

1. Fold this page along dotted line indicated above.
2. Hold page before you so that its left edge is vertically parallel to a tree trunk or other upright structure.
3. Sight across the fold in the direction of hill slope you want to measure.
4. Compare the angle of the fold with the slope of the hill.



WARRANTY STATEMENT

SECTION 1: LIMITED WARRANTY

Husqvarna Forest & Garden Company ("Husqvarna") warrants Husqvarna product to the original purchaser to be free from defects in material and workmanship from the date of purchase for the "Warranty Period" of the product as set forth below:

Lifetime Warranty: All tiller lines against breakage, trimmer shafts, ignition coils and modules on hand held product.

3 Year Warranty: Spindles (on Zero Turn Riders and Commercial Walk-Behinds)

2 Year COMMERCIAL-Warranty: Husqvarna Commercial Turf Equipment—zero turn riders, wide area walks, and ground engaging commercial equipment.

2 Year NON-COMMERCIAL Warranty: Automatic Mower, Riding lawn mowers, yard and garden tractors, walk behind mowers, tillers, chain saws, trimmers, brushcutters, clearing saws, snow blowers, handheld blowers, backpack blowers, hedge trimmers, electrical products and power-assist collection systems for ~~noncom-~~mercial, nonprofessional, noninstitutional or nonincome producing use, except as herein stated.

Emission control system components necessary to comply with CARB-TIER-II and EPA regulations, except for those components which are part of engine systems manufactured by third party engine manufacturers for which the purchaser has received a separate warranty with product information supplied at time of purchase.

1 Year Warranty: Power cutters, stump grinder, pole pruners and pole saws for non-commercial, non-professional, non-institutional or non-income producing use. All trimmers, brushcutters, clearing saws, hovering trimmers, stick edgers, backpack blowers, hand held blowers, hedge trimmers, power-assist collection systems used for commercial, institutional, professional or income producing purposes or use.

Batteries have a one-year prorated limited warranty with 100% replacement during the first 6 months.

90 Day Warranty: Automatic Mower, Chain saws, power cutters, stump grinders, pole saws, pole pruners, snow throwers, model series 580 & 600 walk-behind mowers and commercial turf equipment or any Husqvarna product used for commercial, institutional, professional, or income producing purposes or use except as otherwise provided herein.

Husqvarna Safety Apparel carries a 90-day warranty from the date of the customer's original purchase for defects in material and workmanship. Normal wear, tear or abuse is not covered under warranty. Product must be returned to Charlotte with a warranty claim form. All care and maintenance instructions must be followed as stated by the manufacturer on the care label. The fit of the protective apparel/boot is not covered under warranty.

30 Day Warranty: Replacement parts, accessories including bars and chains, tools and display items.

SECTION 2: HUSQVARNA'S OBLIGATIONS UNDER THE WARRANTY

Husqvarna will repair or replace defective components without charge for parts or labor if a component fails because of a defect in material or workmanship during the warranty period.

SECTION 3: ITEMS NOT COVERED BY THIS WARRANTY

The following items are not covered by this warranty:

- (1) Normal customer maintenance items which become worn through normal regular use, including, but not limited to, belts, blades, blade adapters, bulbs, filters, guide bars, lubricants, rewind springs, saw chain, spark plugs, starter ropes and tines;
- (2) Natural discoloration of material due to ultraviolet light;
- (3) Engine and drive systems not manufactured by Husqvarna; these items are covered by the respective manufacturer's warranty as provided in writing with the product information supplied at the time of purchase; all claims must be sent to the appropriate manufacturer;
- (4) Lawn and garden attachments are covered by a third party which gives a warranty, all claims for warranty should be sent to the manufacturer; and
- (5) Emission Control System components necessary to comply with CARB-TIER-II and EPA regulations which are manufactured by third party engine manufacturer.

SECTION 4: EXCEPTIONS AND LIMITATIONS

This warranty shall be inapplicable to defects resulting from the following:

- (1) Accident, abuse, misuse, negligence and neglect, including stale fuel, dirt, abrasives, moisture, rust, corrosion, or any adverse reaction due to incorrect storage or use habits;
- (2) Failure to operate or maintain the unit in accordance with the Owner's/Operator's manual or instruction sheet furnished by Husqvarna;
- (3) Alterations or modifications that change the intended use of the product or affects the product's performance, operation, safety, or durability, or causes the product to fail to comply with any applicable laws; or
- (4) Additional damage to parts or components due to continued use occurring after any of the above.

REPAIR OR REPLACEMENT AS PROVIDED UNDER THIS WARRANTY IS THE EXCLUSIVE REMEDY OF THE PURCHASER. HUSQVARNA SHALL NOT BE LIABLE FOR ANY INCIDENTAL OR CONSEQUENTIAL DAMAGES FOR BREACH OF ANY EXPRESS OR IMPLIED WARRANTY ON THESE PRODUCTS EXCEPT TO THE EXTENT PROHIBITED BY APPLICABLE LAW. ANY IMPLIED WARRANTY OF MERCHANTABILITY OR FITNESS FOR A PARTICULAR PURPOSE ON THESE PRODUCTS IS LIMITED IN DURATION TO THE WARRANTY PERIOD AS DEFINED IN THE LIMITED WARRANTY STATEMENT. HUSQVARNA RESERVES THE RIGHT TO CHANGE OR IMPROVE THE DESIGN OF THE PRODUCT WITHOUT NOTICE, AND DOES NOT ASSUME OBLIGATION TO UPDATE PREVIOUSLY MANUFACTURED PRODUCTS.

Some states do not allow the exclusion of incidental or consequential damages, or limitations on how long an implied warranty lasts, so the above limitations or exclusions may not apply to you. This warranty gives you specific legal rights, and you may also have other rights which vary from state to state.

SECTION 5: CUSTOMER RESPONSIBILITIES

The product must exhibit reasonable care, maintenance, operation, storage and general upkeep as written in the maintenance section of the Owner's/Operator's manual. Should an operational problem or failure occur, the product should not be used, but delivered as is to an authorized Husqvarna dealer for evaluation. Proof of purchase, as explained in section 6, rests solely with the customer.

SECTION 6: PROCEDURE TO OBTAIN WARRANTY CONSIDERATION

It is the Owner's and Dealer's responsibility to make certain that the Warranty Registration Card is properly filled out and mailed to Husqvarna Forest & Garden Company. This card should be mailed within ten (10) days from the date of purchase in order to confirm the warranty and to facilitate post-sale service.

Proof of purchase must be presented to the authorized Husqvarna dealer in order to obtain warranty service. This proof must include date purchased, model number, serial number, and complete name and address of the selling dealer.

To obtain the benefit of this warranty, the product believed to be defective must be delivered to an authorized Husqvarna dealer in a timely manner, no later than thirty (30) days from date of the operational problem or failure. The product must be delivered at the owner's expense. Pick-up and delivery charges are not covered by this warranty. An authorized Husqvarna dealer can be normally located through the "Yellow Pages" of the local telephone directory or by calling 1-800-HUSKY62 for a dealer in your area.

HUSQVARNA
7349 Statesville Road
Charlotte, NC 28269

531 83 81-23 2002

