

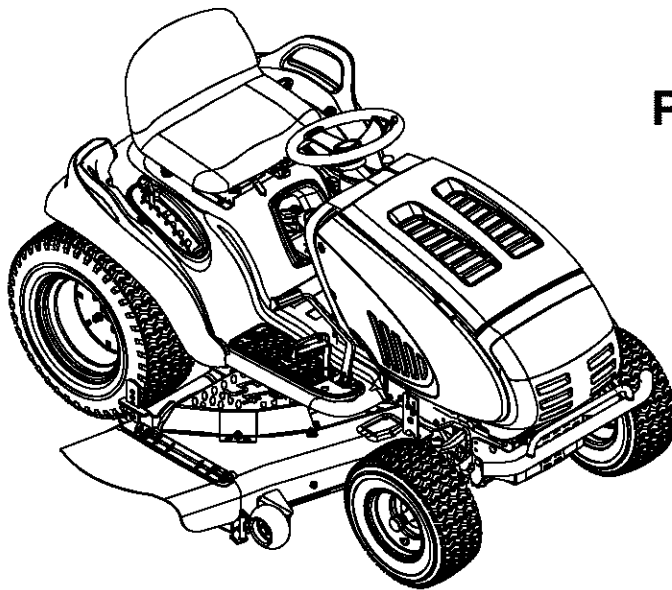

Operator's Manual



Pedal Drive Garden Tractor Models Z809H & Z809K

IMPORTANT: Read safety rules and instructions carefully before operating equipment.

Warning: This unit is equipped with an internal combustion engine and should not be used on or near any unimproved forest-covered, brush-covered or grass-covered land unless the engine's exhaust system is equipped with a spark arrester meeting applicable local or state laws (if any). If a spark arrester is used, it should be maintained in effective working order by the operator. In the State of California the above is required by law (Section 4442 of the California Public Resources Code). Other states may have similar laws. Federal laws apply on federal lands. A spark arrester for the muffler is available through your nearest engine authorized service dealer or contact the service department, P.O. Box 361131 Cleveland, Ohio 44136-0019.

Troy-Bilt LLC, P.O. BOX 361131 CLEVELAND, OHIO 44136-0019

PRINTED IN U.S.A.

FORM NO. 770-10189E
(11/2002)

TABLE OF CONTENTS

Content	Page
Important Safe Operation Practices.....	3
Slope Gauge.....	6
Tractor Set-up.....	7
Know Your Garden Tractor.....	10
Operating Your Garden Tractor.....	13
Making Adjustments.....	16
Maintaining Your Garden Tractor.....	18
Service.....	19
Off-Season Storage.....	24
Attachments & Accessories.....	24
Troubleshooting.....	25
Parts List.....	26

FINDING MODEL NUMBER

This Operator's Manual is an important part of your new Garden Tractor. It will help you assemble, prepare and maintain the unit for best performance. Please read and understand what it says.



Before you start assembling your new equipment, please locate the model plate on the equipment and copy the information from it in the space provided below. This information is very important if you need help from our Customer Support Department or an authorized dealer.

- Locate the model number by looking beneath the seat. A sample model plate is explained below. For future reference, please copy the model and the serial numbers of the equipment in the space below.

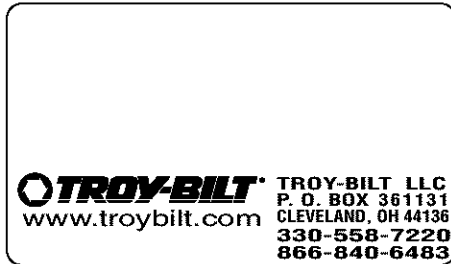

Copy the model number here: _____

Copy the serial number here: _____

ENGINE INFORMATION

The engine manufacturer is responsible for all engine-related issues with regards to performance, power-rating, specifications, warranty and service. Please refer to the engine manufacturer's Owner's/Operator's Manual packed separately with your unit for more information.

CALLING CUSTOMER SUPPORT

If you have difficulty assembling this product or have any questions regarding the controls, operation or maintenance of this unit, please call the Customer Support Department.



Call 1- (330) 558-7220 or 1- (866) 840-6483 to reach a Customer Support representative. Please have your unit's model number and serial number ready when you call. See previous section to locate this information. You will be asked to enter the serial

For more details about your unit, visit our website at www.troybilt.com

SECTION 1: IMPORTANT SAFE OPERATION PRACTICES



WARNING: This symbol points out important safety instructions which, if not followed, could endanger the personal safety and/or property of yourself and others. Read and follow all instructions in this manual before attempting to operate this machine. Failure to comply with these instructions may result in personal injury. When you see this symbol—heed its warning.

DANGER: This machine was built to be operated according to the rules for safe operation in this manual. As with any type of power equipment, carelessness or error on the part of the operator can result in serious injury. This machine is capable of amputating hands and feet and throwing objects. Failure to observe the following safety instructions could result in serious injury or death.

WARNING: Engine exhaust, some of its constituents, and certain vehicle components contain or emit chemicals known to the State of California to cause cancer and birth defects or other reproductive harm.

General Operation

1. Read, understand, and follow all instructions on the machine and in the manual(s) before attempting to assemble and operate. Keep this manual in a safe place for future and regular reference and for ordering replacement parts.
2. Be familiar with all controls and their proper operation. Know how to stop the machine and disengage them quickly.
3. Never allow children under 14 years old to operate this machine. Children 14 years old and over should read and understand the operation instructions and safety rules in this manual and should be trained and supervised by a parent.
4. Never allow adults to operate this machine without proper instruction.
5. To help avoid blade contact or a thrown object injury, keep bystanders, helpers, children and pets at least 75 feet from the machine while it is in operation. Stop machine if anyone enters the area.
6. Thoroughly inspect the area where the equipment is to be used. Remove all stones, sticks, wire, bones, toys, and other foreign objects which could be picked up and thrown by the blade(s). Thrown objects can cause serious personal injury.
7. Plan your mowing pattern to avoid discharge of material toward roads, sidewalks, bystanders and the like. Also, avoid discharging material against a wall or obstruction which may cause discharged material to ricochet back toward the operator.
8. Always wear safety glasses or safety goggles during operation and while performing an adjustment or repair to protect your eyes. Thrown objects which ricochet can cause serious injury to the eyes.
9. Wear sturdy, rough-soled work shoes and close-fitting slacks and shirts. Loose fitting clothes and jewelry can be caught in movable parts. Never operate this machine in bare feet or sandals.
10. Be aware of the mower and attachment discharge direction and do not point it at anyone. Do not operate the mower without the discharge cover or entire grass catcher in its proper place.
11. Do not put hands or feet near rotating parts or under the cutting deck. Contact with the blade(s) can amputate hands and feet.
12. A missing or damaged discharge cover can cause blade contact or thrown object injuries.
13. Stop the blade(s) when crossing gravel drives, walks, or roads and while not cutting grass.
14. Watch for traffic when operating near or crossing roadways. This machine is not intended for use on any public roadway.
15. Do not operate the machine while under the influence of alcohol or drugs.
16. Mow only in daylight or good artificial light.
17. Never carry passengers.
18. Disengage blade(s) before shifting into reverse. Back up slowly. Always look down and behind before and while backing to avoid a back-over accident.
19. Slow down before turning. Operate the machine smoothly. Avoid erratic operation and excessive speed.
20. Disengage blade(s), set parking brake, stop engine and wait until the blade(s) come to a complete stop before removing grass catcher, emptying grass, unclogging chute, removing any grass or debris, or making any adjustments.
21. Never leave a running machine unattended. Always turn off blade(s), place transmission in neutral, set parking brake, stop engine and remove key before dismounting.
22. Use extra care when loading or unloading the machine into a trailer or truck. This unit should not be driven up or down ramp(s), because the unit could tip over, causing serious personal injury. The unit must be pushed manually on ramp(s) to load or unload properly.
23. Muffler and engine become hot and can cause a burn. Do not touch.
24. Check overhead clearances carefully before driving under low hanging tree branches, wires, door openings etc., where the operator may be struck or pulled from the unit, which could result in serious injury.
25. Disengage all attachment clutches, depress the brake pedal completely and shift into neutral before attempting to start engine.
26. Your machine is designed to cut normal residential grass of a height no more than 10". Do not attempt to mow

through unusually tall, dry grass (e.g., pasture) or piles of dry leaves. Dry grass or leaves may contact the engine exhaust and/or build up on the mower deck presenting a potential fire hazard.

27. Use only accessories and attachments approved for this machine by the machine manufacturer. Read, understand and follow all instructions provided with the approved accessory or attachment.
28. Data indicates that operators, age 60 years and above, are involved in a large percentage of riding mower-related injuries. These operators should evaluate their ability to operate the riding mower safely enough to protect themselves and others from serious injury.
29. If situations occur which are not covered in this manual, use care and good judgment. Contact an authorized Service Dealer for assistance.

Slope Operation

Slopes are a major factor related to loss of control and tip-over accidents which can result in severe injury or death. All slopes require extra caution. If you cannot back up the slope or if you feel uneasy on it, do not mow it.

For your safety, use the slope gauge included as part of this manual to measure slopes before operating this unit on a sloped or hilly area. If the slope is greater than 15 degrees as shown on the slope gauge, do not operate this unit on that area or serious injury could result.

Do:

1. Mow up and down slopes, not across. Exercise extreme caution when changing direction on slopes.
2. Watch for holes, ruts, bumps, rocks, or other hidden objects. Uneven terrain could overturn the machine. Tall grass can hide obstacles.
3. Use slow speed. Choose a low enough speed setting so that you will not have to stop or shift while on the slope. Tires may lose traction on slopes even though the brakes are functioning properly. Always keep machine in gear when going down slopes to take advantage of engine braking action.
4. Follow the manufacturer's recommendations for wheel weights or counterweights to improve stability.
5. Use extra care with grass catchers or other attachments. These can change the stability of the machine.
6. Keep all movement on the slopes slow and gradual. Do not make sudden changes in speed or direction. Rapid engagement or braking could cause the front of the machine to lift and rapidly flip over backwards which could cause serious injury.
7. Avoid starting or stopping on a slope. If tires lose traction, disengage the blade(s) and proceed slowly straight down the slope.

Do Not:

1. Do not turn on slopes unless necessary; then, turn slowly and gradually downhill, if possible.
2. Do not mow near drop-offs, ditches or embankments. The mower could suddenly turn over if a wheel is over the edge of a cliff, ditch, or if an edge caves in.
3. Do not try to stabilize the machine by putting your foot on the ground.
4. Do not use a grass catcher on steep slopes.

5. Do not mow on wet grass. It may cause sliding.
6. Do not shift to neutral and coast downhill. Over-speeding may cause the operator to lose control of the machine resulting in serious injury or death.
7. Do not tow heavy attachments (e.g. loaded dump cart, lawn roller, etc.) on slopes greater than 5 degrees. When going down hill, the extra weight tends to push the tractor and may cause you to lose control. (e.g. tractor may speed up, braking and steering ability may be reduced, attachment may jack-knife and tractor may overturn).

Children

1. Tragic accidents can occur if the operator is not alert to the presence of children. Children are often attracted to the machine and the mowing activity. They do not understand the dangers. Never assume that children will remain where you last saw them.
 - a. Keep children out of the mowing area and in watchful care of a responsible adult other than the operator. Be alert and turn machine off if a child enters area.
 - b. Before and while backing, look behind and down for small children.
 - c. Never carry children, even with the blade(s) shut off. They may fall off and be seriously injured or interfere with safe machine operation.
 - d. Use extreme care when approaching blind corners, doorways, shrubs, trees or other objects that may block your vision of a child who may run into the machine.
 - e. Disengage the cutting blade(s) before shifting in reverse. The "No-Cut-In Reverse" feature is a reminder not to cut in reverse and to help avoid back over accidents. Do not defeat it.
 - f. Keep children away from hot or running engines. They can suffer burns from a hot muffler.
 - g. Remove key when machine is unattended to prevent unauthorized operation.
8. Never allow children under 14 years to operate the machine. Children 14 years old and over should read and understand the operation and safety rules in this manual and should be trained and supervised by a parent.

Towing

1. Tow only with a machine that has a hitch designed for towing. Do not attach towed equipment except at the hitch point.
2. Follow the manufacturers recommendation for weight limits for towed equipment and towing on slopes.
3. Never allow children or others in or on towed equipment.
4. On slopes, the weight of the towed equipment may cause loss of traction and loss of control.
5. Travel slowly and allow extra distance to stop.
6. Do not shift to neutral and coast downhill.

Service

Safe Handling Of Gasoline:

1. **To avoid personal injury or property damage** use extreme care in handling gasoline. **Gasoline is**

extremely flammable and the vapors are explosive. Serious personal injury can occur when gasoline is spilled on yourself or your clothes which can ignite. Wash your skin and change clothes immediately.

- a. Use only an approved gasoline container.
- b. Never fill containers inside a vehicle or on a truck or trailer bed with a plastic liner. Always place containers on the ground away from your vehicle before filling.
- c. When practical, remove gas-powered equipment from the truck or trailer and refuel it on the ground. If this is not possible, then refuel such equipment on a trailer with a portable container, rather than from a gasoline dispenser nozzle.
- d. Keep the nozzle in contact with the rim of the fuel container opening at all times until fueling is complete. Do not use a nozzle lock-open device.
- e. Extinguish all cigarettes, cigars, pipes and other sources of ignition.
- f. Never fuel machine indoors.
- g. Never remove gas cap or add fuel while the engine is hot or running. Allow engine to cool at least two minutes before refueling.
- h. Never over fill fuel tank. Fill tank to no more than ½ inch below bottom of filler neck to allow space for fuel expansion.
- i. Replace gasoline cap and tighten securely.
- j. If gasoline is spilled, wipe it off the engine and equipment. Move unit to another area. Wait 5 minutes before starting the engine.
- k. To reduce fire hazards, keep machine free of grass, leaves, or other debris build-up. Clean up oil or fuel spillage and remove any fuel soaked debris.
- l. Never store the machine or fuel container inside where there is an open flame, spark or pilot light as on a water heater, space heater, furnace, clothes dryer or other gas appliances.
- m. Allow a machine to cool at least 5 minutes before storing.

General Service:

1. Never run an engine indoors or in a poorly ventilated area. Engine exhaust contains carbon monoxide, an odorless, and deadly gas.
2. Before cleaning, repairing, or inspecting, make certain the blade(s) and all moving parts have stopped. Disconnect the spark plug wire and ground against the engine to prevent unintended starting.
3. Periodically check to make sure the blades come to complete stop within approximately (5) five seconds after

operating the blade disengagement control. If the blades do not stop within the this time frame, your unit should be serviced professionally by an authorized Service Dealer.

4. Check brake operation frequently as it is subjected to wear during normal operation. Adjust and service as required.
5. Check the blade(s) and engine mounting bolts at frequent intervals for proper tightness. Also, visually inspect blade(s) for damage (e.g., excessive wear, bent, cracked).
Replace the blade(s) with the original equipment manufacturer's (O.E.M.) blade(s) only, listed in this manual. "Use of parts which do not meet the original equipment specifications may lead to improper performance and compromise safety!"
6. Mower blades are sharp. Wrap the blade or wear gloves, and use extra caution when servicing them.
7. Keep all nuts, bolts, and screws tight to be sure the equipment is in safe working condition.
8. Never tamper with the safety interlock system or other safety devices. Check their proper operation regularly.
9. After striking a foreign object, stop the engine, disconnect the spark plug wire(s) and ground against the engine. Thoroughly inspect the machine for any damage. Repair the damage before starting and operating.
10. Never attempt to make adjustments or repairs to the machine while the engine is running.
11. Grass catcher components and the discharge cover are subject to wear and damage which could expose moving parts or allow objects to be thrown. For safety protection, frequently check components and replace immediately with original equipment manufacturer's (O.E.M.) parts only, listed in this manual. "Use of parts which do not meet the original equipment specifications may lead to improper performance and compromise safety!"
12. Do not change the engine governor settings or over-speed the engine. The governor controls the maximum safe operating speed of the engine.
13. Maintain or replace safety and instruction labels, as necessary.
14. Observe proper disposal laws and regulations for gas, oil, etc. to protect the environment.

Your Responsibility

- Restrict the use of this power machine to persons who read, understand and follow the warnings and instructions in this manual and on the machine.



SECTION 2: SLOPE GAUGE

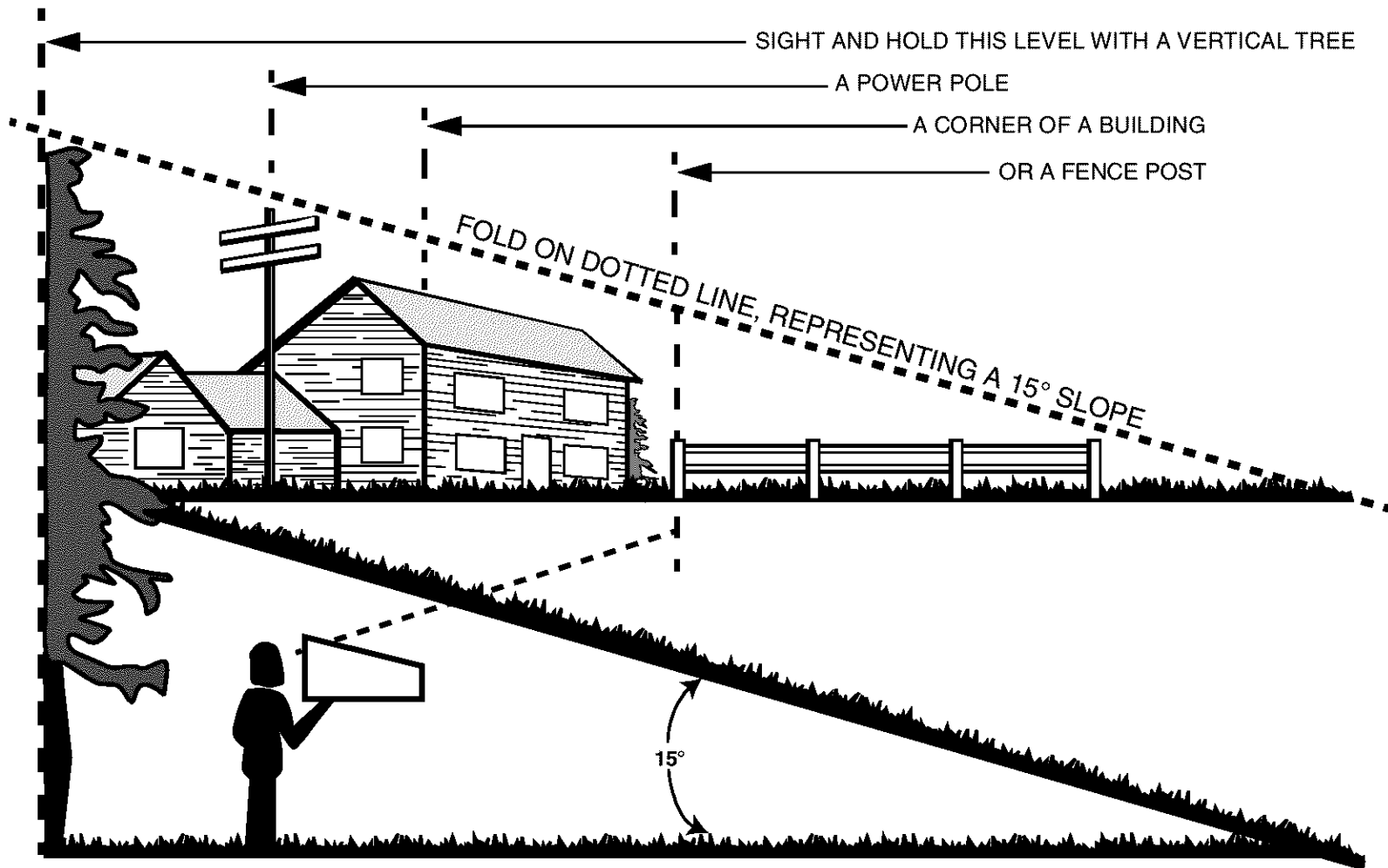

WARNING

Do not mow on inclines with a slope in excess of 15 degrees (a rise of approximately 2-1/2 feet every 10 feet). A riding mower could overturn and cause serious injury. If operating a walk-behind mower on such a slope, it is extremely difficult to maintain your footing and you could slip, resulting in serious injury. Operate RIDING mowers up and down slopes, never across the face of slopes.

SECTION 3: SETTING UP THE TRACTOR

NOTE: Any reference here to the RIGHT or LEFT side of the tractor is observed from operator's position.

Attaching Battery Cables

NOTE: The positive battery terminal is marked Pos. (+). The negative battery terminal is marked Neg. (-).

- The positive cable (heavy red wire) is secured to the positive battery terminal (+) with a hex bolt and hex nut at the factory. Make certain that the rubber boot covers the terminal to help protect it from corrosion.
- Remove the hex bolt and wing nut from the negative cable.
- Remove the black plastic cover, if present, from the negative battery terminal and attach the negative cable (heavy black wire) to the negative battery terminal (-) with the bolt and wing nut.
- Make certain the hold-down strap is in position over the battery, securing it in place. See Figure 1.

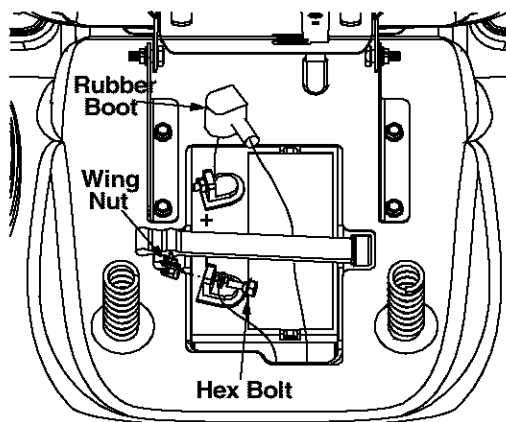

Figure 1

NOTE: If the battery is put into service after the date shown on top of battery, charge the battery as instructed on page 24 of this manual prior to operating the tractor.

Gas and Oil Fill-up

The gasoline tank is located under the hood and has a capacity of either two or three gallons. Do not overfill.



WARNING: Use extreme care when handling gasoline. Gasoline is extremely flammable and the vapors are explosive. Never fuel machine indoors or while the engine is hot or running. Extinguish cigarettes, cigars, pipes, and other sources of ignition.

Service the engine with gasoline and oil as instructed in the separate *Briggs & Stratton Operator/Owner Manual* packed with your tractor. Read instructions carefully.

IMPORTANT: Your tractor is shipped with motor oil in the engine. However, you must check the oil level before operating. Be careful not to overfill.

Shipping Brace Removal



WARNING: Make sure the tractor engine is off. Remove ignition key, and set the parking brake before removing the shipping brace.

- Locate the shipping brace and accompanying warning tag on the right side of the tractor, between the discharge chute and the deck. See Figure 2.

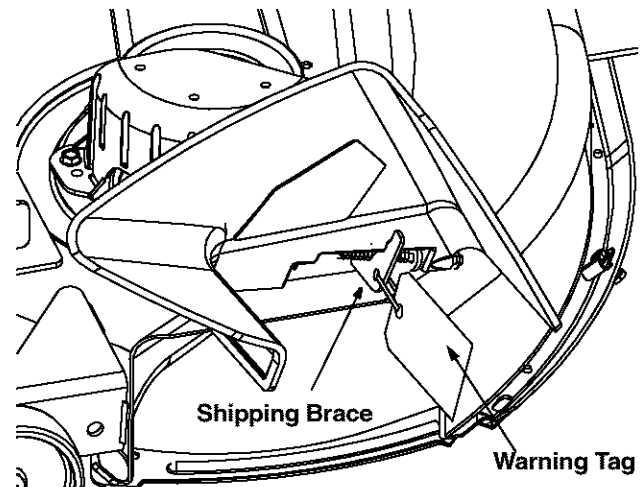

Figure 2

- While holding the discharge chute with your left hand, remove the shipping brace with your right hand by grasping it between your thumb and index finger and rotating it clockwise.



WARNING: The shipping brace, used for packaging purposes only, must be removed and discarded before operating tractor.

WARNING: The mowing deck is capable of throwing objects. Failure to operate the tractor without the discharge cover in the proper operating position could result in serious personal injury and/or property damage.

Attaching the Deck (Model 809K only)



WARNING: Before attaching the cutting deck, engage the parking brake, turn the ignition key to the OFF position and remove the key from the switch to avoid accidental starting.

- Adjust the deck roller height so that the clevis pins are inserted in the second hole (from the top) of both the left-hand deck roller bracket and the right-hand deck roller bracket. See Figure 5 or refer to **Deck Roller Height Adjustment** on page 9 for more detailed instructions on adjusting the deck roller upward or downward.
- Raise the deck lift arms up and out of the way by placing the deck lift lever in the top notch on the right fender.
- Gently slide the cutting deck beneath the tractor from the right side.
- Move the cutting deck into position so that the hooks found on the front end of the deck fit snugly around the deck stabilizer rod.

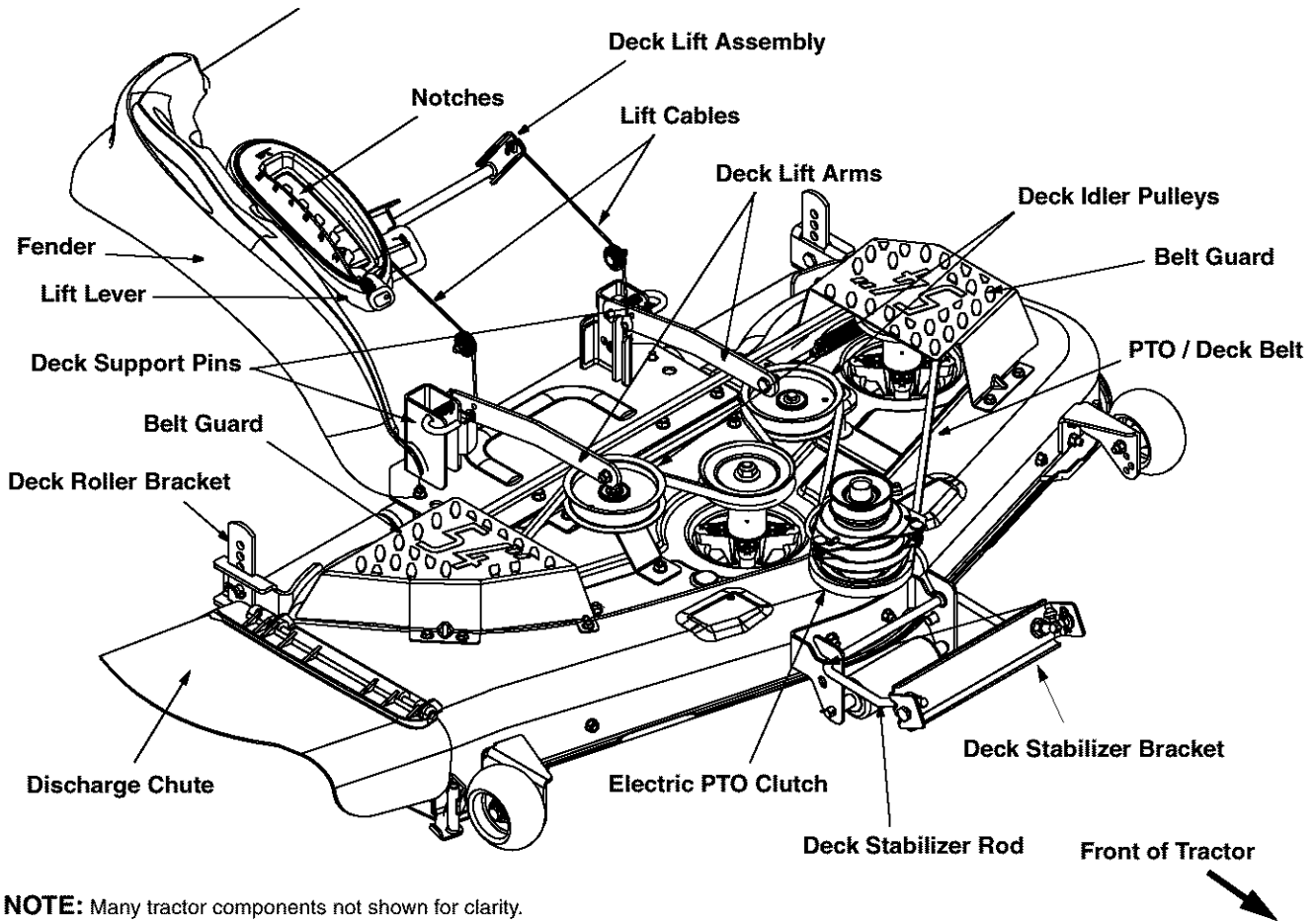

NOTE: Many tractor components not shown for clarity.

Figure 3

NOTE: The stabilizer rod may be secured to the tractor frame with a plastic cable tie for shipping reasons. If so, carefully cut the cable tie before mounting the front of the cutting deck.

- Lower the deck lift arms by placing the lift lever in the bottom notch on the right fender.
- Pull the deck support pin (on the left side of the deck) outward and align it with the hole on the rear of the left deck lift arm before releasing the pin to lock it in place as shown in Figure 5. Repeat on the right side.

Installing the PTO/Deck Belt

- Make certain that the PTO/Deck belt is routed around the spindle pulleys (found beneath the belt

guards) and both idler pulleys as illustrated in Figure 4 before proceeding.

- Relieve tension on the deck idler by inserting a 3/8" drive ratchet wrench (set to "loosen") in the hole found in the idler bracket and pivoting the wrench handle counterclockwise. See Figure 4.

IMPORTANT: Be certain that the FLAT side of the PTO/Deck belt is the side coming in contact with the deck idler pulleys.

- With the tension relieved, carefully route the belt around the electric PTO clutch.

NOTE: If necessary, refer to the decal found on the deck's surface or on page 19 of this manual for a detailed belt-routing diagram.

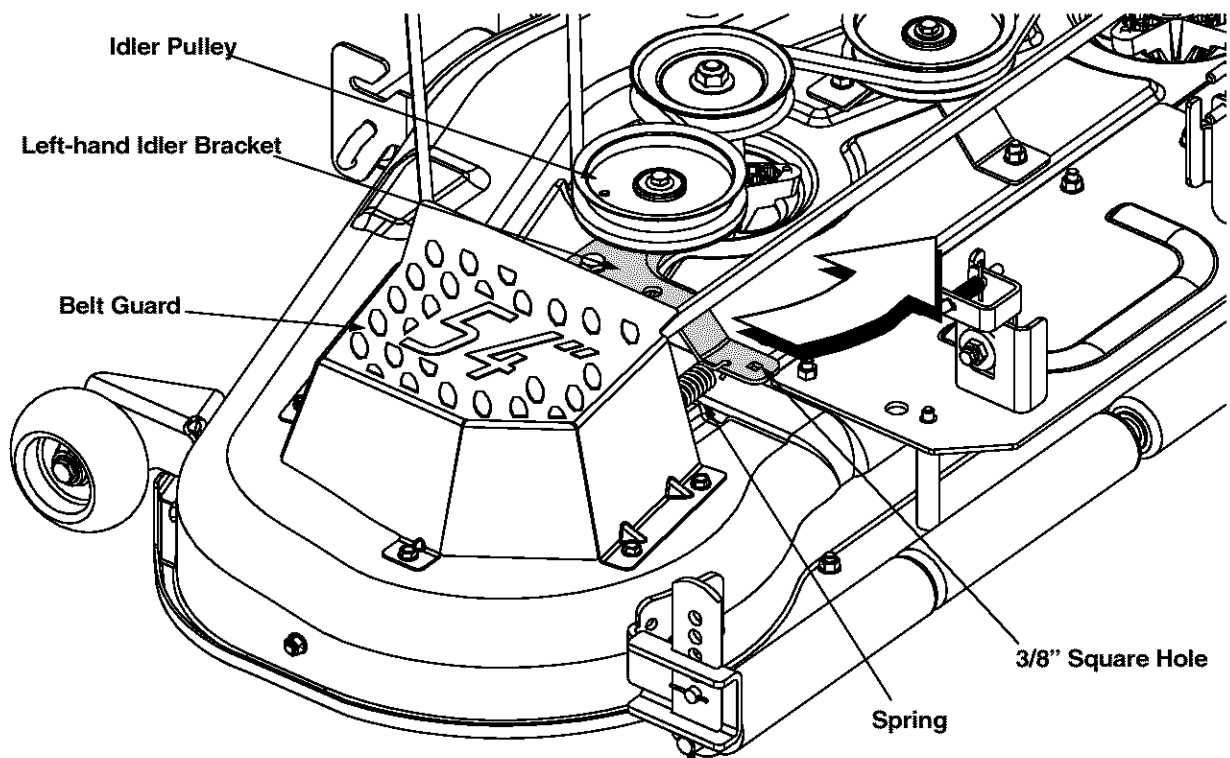

Figure 4

Deck Roller Height Adjustment

To adjust the height of the rollers found on the rear of the mowing deck upward or downward, proceed as follows:

- Place the deck lift lever in the bottom notch (lowest position).
- Remove the clevis pins and hairpin clips from the deck roller brackets on the left and right sides of the cutting deck. See Figure 5.
- Position the deck roller brackets up or down through the slots on the rear of the deck until desired position is reached, then re-attach with the clevis pins and hairpin clips just removed. See Figure 5.

IMPORTANT: Be certain that the left roller bracket and the right roller bracket are set in the same position.

IMPORTANT: After mounting the cutting deck, perform any adjustments on the deck, if necessary, prior to operating the tractor. Refer to page 16 for instructions.

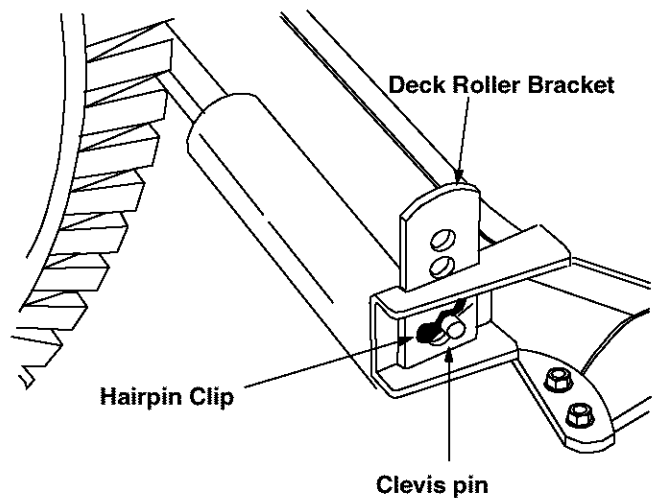

Figure 5

SECTION 4: KNOW YOUR GARDEN TRACTOR

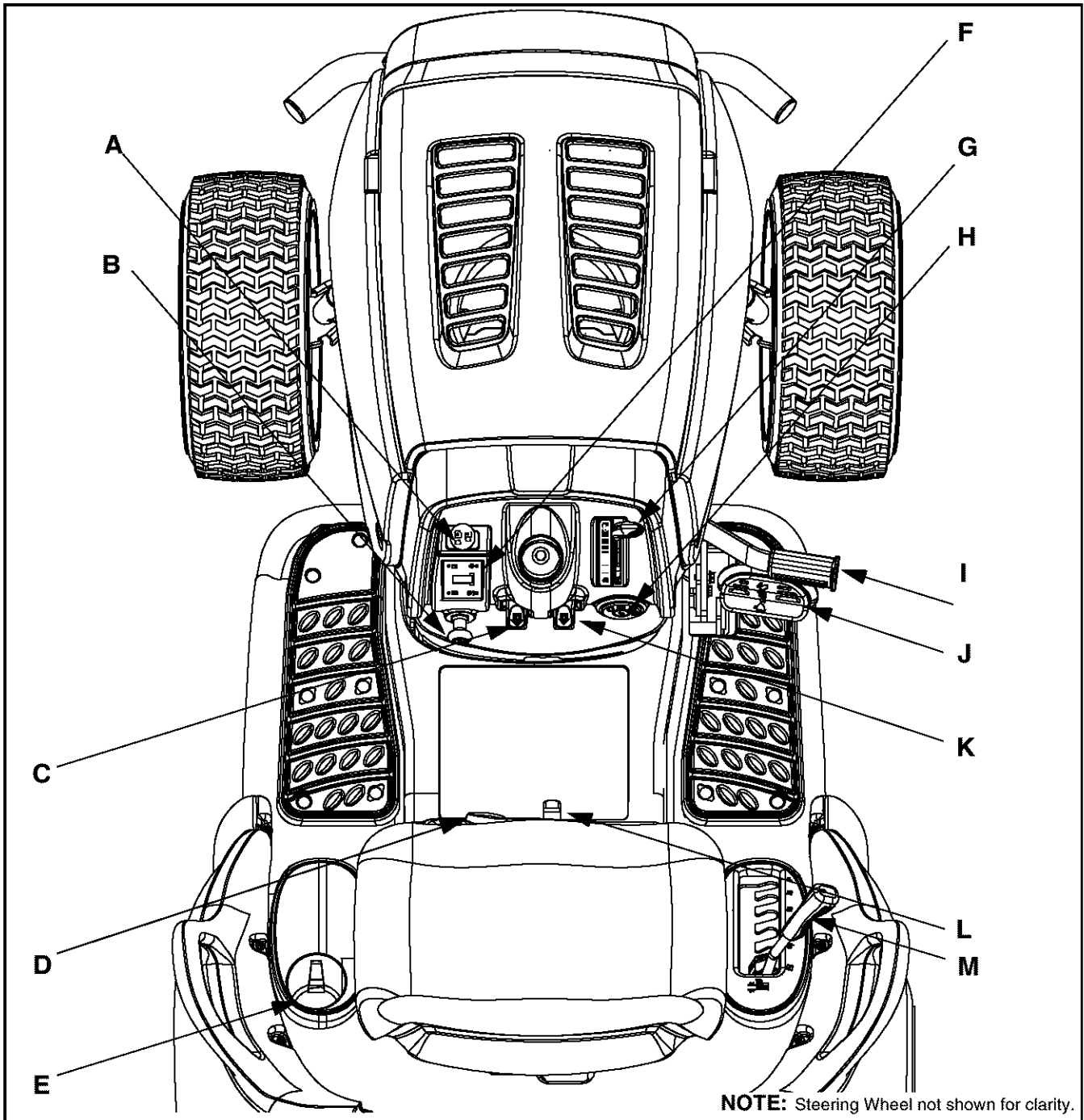

Figure 6

- | | | | |
|---|--------------------------------------|---|-----------------------|
| A | PTO (Power Take-off) Knob | H | Ignition Switch |
| B | Choke Control | I | Brake Pedal |
| C | Parking Brake Button | J | Drive Pedal |
| D | Shift Lever | K | Cruise Control Button |
| E | Cup Holder | L | Seat Adjustment Lever |
| F | Systems Indicator Monitor/Hour Meter | M | Deck Lift Lever |
| G | Throttle Control Lever | | |

Throttle Control Lever

The throttle control lever is located on the right side of the tractor's dash panel. This lever controls the speed of the engine. When set in a given position, the throttle will maintain a uniform engine speed.

IMPORTANT: When operating the tractor with the cutting deck engaged, be certain that the throttle lever is **always** in the FAST (rabbit) position.

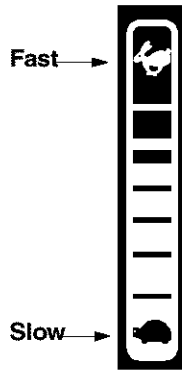

Choke Control

The choke control can be found on the left side of the dash panel and is activated by pulling the knob outward. Activating the choke control closes the choke plate on the carburetor and aids in starting the engine. Refer to page 13 of this manual for detailed starting instructions.

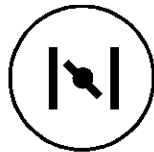

Brake Pedal

The brake pedal is located on the right front side of the tractor above the drive pedal along the running board. The brake pedal can be used for sudden stops or setting the parking brake.



NOTE: Brake pedal must be fully depressed to activate the safety interlock switch when starting the tractor.

Ignition Switch

To start the engine, insert the key into the ignition switch and turn clockwise to the **START** position. Release the key into the **ON** position once engine has fired. Refer to page 13 for detailed starting instructions.

The ignition switch is also used to operate the tractor's headlights. Refer to page 15 for detailed instructions.

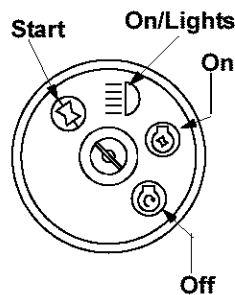

WARNING: Never leave a running machine unattended. Always disengage PTO, move shift lever into neutral position, set parking brake, stop engine and remove key to prevent unintended starting.

Drive Pedal

The drive pedal is located below the brake pedal on the right front side of the tractor along the running board. Depress the drive pedal with your right foot when the tractor shift lever is in either FORWARD or REVERSE to cause the tractor to move. Ground speed is also controlled with the drive pedal. The further down the pedal is depressed, the faster the tractor will travel. The pedal will return to its original position when it is not depressed.

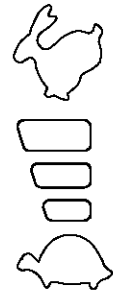

IMPORTANT: Always set the parking brake when leaving the tractor unattended.

Cup Holder

The tractor's cup holder is located on the fender to the left of the seat, just to the rear of the parking brake lever.

Electric PTO (Power Take-off) Knob

To engage the power to the cutting deck or other (separately available) attachments, pull outward on the PTO knob. Push the PTO knob inward to disengage the power to the cutting deck.

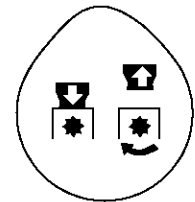

NOTE: The PTO knob **must** be in the disengaged (OFF) position when starting the engine, when traveling in reverse and if the operator leaves the seat.

Shift Lever

The shift lever is located on the front of the fender between the operator's legs and has four positions, FORWARD—HI, FORWARD—LO, NEUTRAL and REVERSE. The brake pedal must be depressed and the tractor must not be in motion when moving the shift lever. Always bring the tractor to a complete stop prior to moving the shift lever from FORWARD—HI to FORWARD—LO or vice-versa.

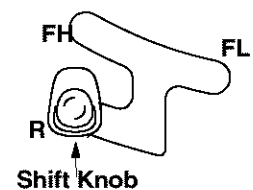

IMPORTANT: Never force the shift lever. Doing so may result in serious damage to the tractor's transmission.

Seat Adjustment Lever

To adjust the seat forward or backward, slide the seat adjustment lever to the left and reposition the seat to the desired position. Once a comfortable position is found, release the seat adjustment lever to lock the seat in place. Refer to **Seat Adjustment** on page 17 of this manual for more detailed instructions.

Deck Lift Lever

Found on your tractor's right fender, the deck lift lever is used to change the height of the cutting deck. To use, move the lever to the left, then place in the notch best suited for your application.

Parking Brake Button

To set the parking brake, fully depress the brake pedal and push the parking brake button in. Hold the button in while taking your foot off the brake pedal. Both the parking button and the brake pedal will then stay depressed. To release the parking brake, depress the brake pedal slightly. The parking brake button will then return to its original position.

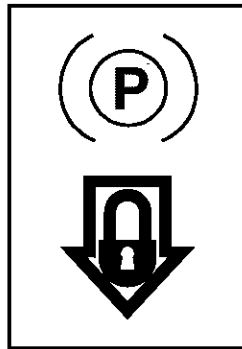

NOTE: The parking brake must be set if the operator leaves the seat with the engine running or the engine will automatically shut off.

IMPORTANT: Always set the parking brake when leaving the tractor unattended.

Cruise Control Button

The cruise control button is located on the tractor dash panel to the left of the ignition switch. Push the cruise control button while traveling forward at a desired speed. While holding the button in, release pressure from the drive pedal. This will engage the cruise control and allow the tractor to remain at that speed without applying pressure to the drive pedal. Depress the brake pedal or the drive pedal to deactivate cruise control. Refer to **Operations** section in this manual for detailed instructions.

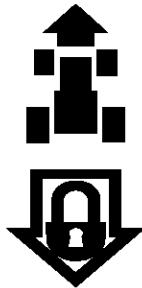

NOTE: Cruise control can not be engaged at the tractor's fastest ground speed. If the operator should attempt to do so, the tractor will automatically decelerate to the fastest optimal mowing ground speed.

Systems Indicator Monitor / Hour Meter

Your tractor is equipped with four indicator lights and an hour meter located on the left side of the dash panel. See Figure 7.

If the brake light or PTO light illuminates when attempting to start the unit, proceed as follows:

Indication	Remedy
Brake light on	Engage the parking brake.
PTO light on	Move PTO knob to the disengaged(OFF) position.

It is normal for the oil light and the battery light to illuminate while the engine is cranking, but if either illuminates while the **engine is running**, follow the steps below as per indication:

Indication	Remedy
Oil light on	Stop the tractor immediately and check the crankcase oil level as instructed in the <i>engine</i> manual. Add oil as required.
Battery light on	Indicates that the battery is in need of a charge or that the engine's charging system is not generating sufficient amperage. Refer to Battery on page 19 of this manual for charging procedure or have the engine's charging system checked by an authorized <i>Briggs & Stratton</i> dealer.

The hour meter operates whenever the engine is running and records the actual hours of tractor operation.

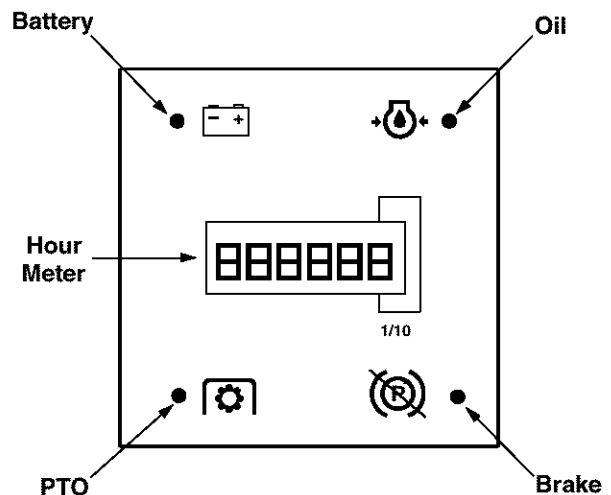

Figure 7

Cargo Net

Conveniently located on the tractor's dash panel, the cargo net can be used to store personal items while operating the lawn tractor.

SECTION 5: OPERATING YOUR GARDEN TRACTOR



WARNING

AVOID SERIOUS INJURY OR DEATH

- GO UP AND DOWN SLOPES, NOT ACROSS.
- AVOID SUDDEN TURNS.
- DO NOT OPERATE THE UNIT WHERE IT COULD SLIP OR TIP.
- IF MACHINE STOPS GOING UPHILL, STOP BLADE(S) AND BACK DOWNHILL SLOWLY.
- DO NOT MOW WHEN CHILDREN OR OTHERS ARE AROUND.
- NEVER CARRY CHILDREN, EVEN WITH BLADES OFF.
- LOOK DOWN AND BEHIND BEFORE AND WHILE BACKING.
- KEEP SAFETY DEVICES (GUARDS, SHIELDS, AND SWITCHES) IN PLACE AND WORKING.
- REMOVE OBJECTS THAT COULD BE THROWN BY THE BLADE(S).
- KNOW LOCATION AND FUNCTION OF ALL CONTROLS.
- BE SURE BLADE(S) AND ENGINE ARE STOPPED BEFORE PLACING HANDS OR FEET NEAR BLADE(S).
- BEFORE LEAVING OPERATOR'S POSITION, DISENGAGE BLADE(S), PLACE THE SHIFT LEVER IN NEUTRAL, ENGAGE BRAKE LOCK, SHUT ENGINE OFF AND REMOVE KEY.

READ OPERATOR'S MANUAL

Safety Interlock Switches

This tractor is equipped with a safety interlock system for the protection of the operator. If the interlock system should ever malfunction, do not operate the tractor. Contact an authorized service dealer. The safety interlock system prevents the engine from cranking or starting unless the parking brake is engaged, and the PTO knob is in the disengaged (OFF) position.

The engine will automatically shut off if

1. the operator leaves the seat before engaging the parking brake;
2. the operator leaves the tractor's seat with the PTO knob in the engaged (ON) position, regardless of whether the parking brake is engaged; and
3. the PTO knob is moved to engaged (ON) position with the shift lever in position for reverse travel.



WARNING: Do not operate the tractor if the interlock system is malfunctioning. This system was designed for your safety and protection.

Setting the Cutting Height

- Select the height position of the cutting deck by placing the deck lift lever in any of the six different cutting height notches on the right side of the fender.
- Adjust the deck wheels so that they are between ¼-inch and ½-inch above the ground when the tractor is on a smooth, flat surface such as a driveway.



WARNING: Keep hands and feet away from the discharge opening of the cutting deck.

NOTE: The deck wheels are an anti-scalp feature of the deck and are not designed to support the weight of the cutting deck.

Refer to **Leveling the Deck** on page 16 of this manual for more detailed instructions regarding various deck adjustments.

Starting the Engine

NOTE: Refer to page 7 of this manual for gasoline and oil fill-up instructions.

- Insert the tractor key into the ignition switch.
- Place the PTO knob in the disengaged (OFF) position.
- Engage the tractor's parking brake.
- Place the throttle control in the FAST (rabbit) position.
- Pull the choke control outward.
- Turn the ignition key clockwise to the START position. After the engine starts, release the key. It will return to the ON position.

IMPORTANT: Do NOT hold the key in the START position for longer than ten seconds at a time. Doing so may cause damage to your engine's electric starter.

- After the engine starts, deactivate the choke control and place the throttle control in the FAST position.

NOTE: Do NOT leave the choke control on while operating the tractor. Doing so will result in a "rich" fuel mixture and cause the engine to run poorly.

Stopping the Engine



WARNING: If you strike a foreign object, stop the engine, disconnect the spark plug wire(s) and ground against the engine. Thoroughly inspect the machine for any damage. Repair the damage before restarting and operating.

- If the blades are engaged, place the PTO knob in the disengaged (OFF) position.
- Turn the ignition key counterclockwise to the OFF position.
- Remove the key from the ignition switch to prevent unintended starting.

Driving The Tractor



WARNING: Avoid sudden starts, excessive speed and sudden stops.



WARNING: Do not leave the seat of the tractor without first placing the PTO knob in the disengaged (OFF) position, depressing the brake pedal and engaging the parking brake. If leaving the tractor unattended, also turn the ignition key off and remove the key.

- Depress the brake pedal to release the parking brake and let the pedal up. Move the throttle lever into the FAST (rabbit) position.

IMPORTANT: Do not use the shift lever to change the direction of travel when the tractor is in motion. Always use the brake pedal to bring the tractor to a complete stop before shifting.

- To move forward, place the shift lever in the FORWARD position, then slowly depress the drive pedal until the desired speed is achieved.
- To move in reverse, place the shift lever in the REVERSE position, check that the area behind is clear then slowly depress the drive pedal.

Engaging the Parking Brake

To engage the parking brake:

- Fully depress the brake pedal and hold it there while gently pushing the parking brake button inward.
- Hold the parking brake button in while removing your foot from the brake pedal.
- Once engaged, the parking brake button and the brake pedal will lock in the “down” position.

To disengage the parking brake:

- Slightly depress the brake pedal.

NOTE: *The parking brake must be engaged if the operator leaves the seat with the engine running or the engine will automatically shut off.*

Operating the Headlights

To turn the tractor’s headlights on:

- Start the engine following the instructions earlier in this section.
- Turn the key one notch counterclockwise into the On/Lights position of the ignition switch. Refer to figure on page 11.

To turn the tractor’s headlights off:

- Turn the key either into the On position (to leave the engine running) or the Off position (to shut the engine off).

NOTE: *Never move the key into the Start position while the engine is running. Doing so may cause damage to your engine’s electric starter.*

Driving On Slopes

Refer to the **SLOPE GAUGE** on page 6 to help determine slopes where you may operate the tractor safely.



WARNING: Do not mow on inclines with a slope in excess of 15 degrees (a rise of approximately 2-1/2 feet every 10 feet). The tractor could overturn and cause serious injury.

- Mow up and down slopes, NEVER across.
- Exercise extreme caution when changing direction on slopes.
- Watch for holes, ruts, bumps, rocks, or other hidden objects. Uneven terrain could overturn the machine. Tall grass can hide obstacles.
- Avoid turns when driving on a slope. If a turn must be made, turn downwards on the slope. Turning upwards on a slope greatly increases the chance of a roll over.
- Avoid stopping when driving up a slope. If it is necessary to stop while driving up a slope, start up smoothly and carefully to reduce the possibility of flipping the tractor over backward.

Setting the Cruise Control

NOTE: *The cruise control feature should only be utilized while traveling in the forward direction.*

Engaging Cruise Control

- Place the shift lever in the FORWARD position, then slowly depress the drive pedal until the desired speed is achieved.
- Lightly depress the cruise control button.
- While continuing to hold the cruise button in, lift your foot from the drive pedal (you should feel the cruise latch engage).
- Once engaged, the cruise control button and the drive pedal will lock in the “down” position, and the tractor will maintain the same forward speed.

NOTE: *Cruise control can not be engaged at the tractor’s fastest ground speed. If the operator should attempt to do so, the tractor will automatically decelerate to the fastest optimal mowing ground speed.*

Disengaging Cruise Control

Choose one of the following two methods:

1. Depress the brake pedal to disengage the cruise control and stop the tractor.
2. Lightly depress the drive pedal.

Changing to Reverse when Cruise Control is Engaged

- Depress the brake pedal to disengage the cruise control and bring the tractor to a complete stop.
- Place the shift lever in the REVERSE position, look to the rear to ensure the path is empty, and depress the drive pedal.

Using the Deck Lift Lever

To raise the cutting deck, move the deck lift lever to the left, then place it in the notch best suited for your application. Refer to **Setting The Cutting Height** earlier in this section.

Engaging the PTO

Engaging the PTO transfers power to the cutting deck or other (separately available) attachments. To engage the PTO, proceed as follows:

- Move the throttle control lever to the FAST (rabbit) position.
- Pull the PTO knob outward into the engaged (ON) position. See Figure 8.

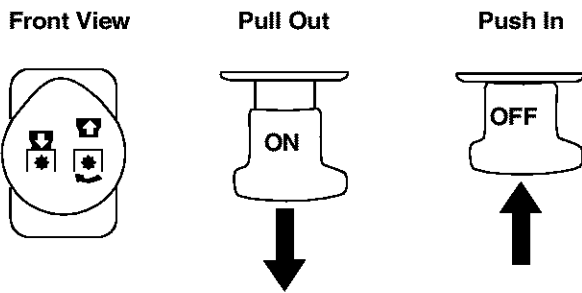

Figure 8

- Keep the throttle lever in the FAST (rabbit) position for the most efficient use of the cutting deck or other (separately available) attachments

IMPORTANT: The electric PTO clutch will automatically shut off if the PTO is engaged with the shift lever in position for reverse travel. Refer to **Safety Interlock Switches** on page 13.

Mowing



WARNING: To help avoid blade contact or a thrown object injury, keep bystanders, helpers, children and pets at least 75 feet from the machine while it is in operation. Stop machine if anyone enters the area.

The following information will be helpful when using the cutting deck with your tractor.



WARNING: Plan your mowing pattern to avoid discharge of materials toward roads, sidewalks, bystanders and the like. Also, avoid discharging material against a wall or obstruction which may cause discharged material to ricochet back toward the operator.

- Do not mow at high ground speed, especially if a mulch kit or grass collector is installed.
- For best results it is recommended that the first two laps be cut with the discharge thrown towards the center. After the first two laps, reverse the direction to throw the discharge to the outside for the balance of cutting. This will give a better appearance to the lawn.
- Do not cut the grass too short. Short grass invites weed growth and yellows quickly in dry weather.
- Mowing should always be done with the engine at full throttle.
- In heavier conditions, it may be better to go back over the cut area a second time to get a clean cut.
- Do NOT attempt to mow heavy brush and weeds and extremely tall grass. Your tractor is designed to mow lawns, NOT clear brush.
- Keep the blades sharp and replace the blades when worn. Refer to **Cutting Blades** on page 22 of this manual for proper blade sharpening instructions.

SECTION 6: MAKING ADJUSTMENTS



WARNING: Never attempt to make any adjustments while the engine is running, except where specified in the manual.

WARNING: Disconnect the spark plug wire(s) and ground against the engine before performing any adjustments, repairs or maintenance.

Parking Brake



WARNING: Never attempt to adjust the brakes while the engine is running. Always disengage PTO, move shift lever into neutral position, stop engine and remove key to prevent unintended starting.

Adjust the brake if

1. the tractor does not stop completely when the brake pedal is completely depressed; or
2. the tractor's rear wheels roll even with the parking brake applied.

Locate the brake disc on right of the transmission in the rear of the tractor and adjust as follows:

- Looking at the transmission from the right side of the tractor, locate the compression spring and brake disc.
- Loosen, but do NOT remove, the hex nut found on the right side of the brake assembly.
- Using a feeler gauge, set the gap between the brake disc and the brake puck at .011".
- Re-tighten the hex nut loosened earlier.

Seat



WARNING: Before operating this machine, make sure the seat is engaged in the seat stop, stand behind the machine and pull back on seat until fully engaged into stop.

- To adjust the position of the seat, move the seat adjustment lever to the left and slide the seat forward or rearward. Make sure seat is locked into position before operating the tractor.

Steering

Adjust the steering drag links if

1. the tractor turns tighter in one direction than the other; or
2. while the ball joints are being replaced.

Adjust the drag links so that equal lengths are threaded into the ball joints on the left and the right respectively.

- Loosen the jam nut found on the drag link at the rear of the ball joint. See Figure 9.

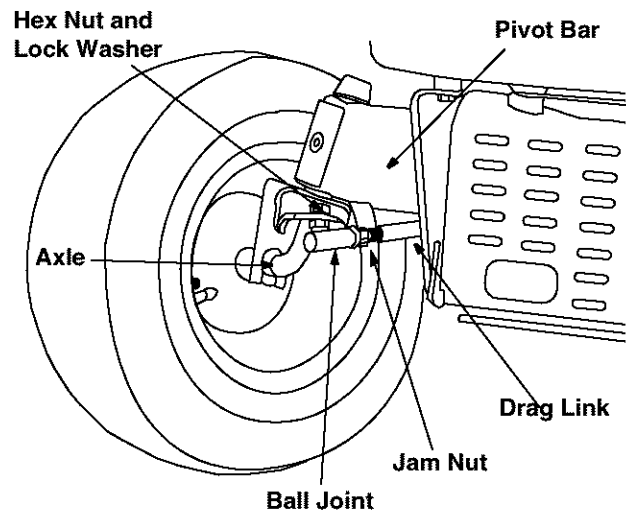

Figure 9

- Remove the hex nut and lock washer on the top of ball joint. See Figure 9.
- Thread the ball joint toward the jam nut to shorten the drag link. Thread the ball joint away from the jam nut to lengthen the drag link.
- Replace hex nut and lock washer and retighten the jam nut after proper adjustment is achieved.

NOTE: Threading the ball joints too far onto the drag links will cause the front tires to "toe-in" too far. Proper toe-in is between 1/16" and 5/16".

Front tire toe-in can be measured as follows:

- Place the steering wheel in position for straight ahead travel.
- In front of the axle, measure the distance horizontally from the inside of the left rim to the inside of the right rim. Note the distance.
- Behind the axle, measure the distance horizontally from the inside of the left rim to the inside of the right rim. Note the distance.
- The measurement taken in front of the axle should be between 1/16" and 5/16" less than the measurement taken behind the axle. Adjust if necessary.

Leveling the Deck

NOTE: Check the tractor's tire pressure before performing any deck leveling adjustments. Refer to **Tires** on page 24 for information regarding tire pressure.

Front To Rear

The front of the cutting deck is supported by a stabilizer bar that can adjusted to level the deck from front to rear. The front of the deck should be between 1/4-inch and 3/8-inch lower than the rear of the deck. Adjust if necessary as follows:

- With the tractor parked on a firm, level surface, place the deck lift lever in the top notch (highest position) and rotate the blade nearest the discharge chute so that it is parallel with the tractor.
- Measure the distance from front of the blade tip to the ground and rear of the blade tip to the ground.
- The first measurement taken should be between 1/4" and 3/8" less than the second measurement. Determine the approximate distance necessary for proper adjustment and proceed to the next step.
- Loosen the two jam nuts on the rear side of the deck stabilizer bracket. See Figure 10A.
- Locate the two lock nuts on the opposite side of the stabilizer bracket. See Figure 10A. Tighten the lock nuts to raise the front of the deck; loosen the lock nuts to lower the front of the deck.
- Retighten the two jam nuts loosened earlier when proper adjustment is achieved.

Side to Side

If the cutting deck appears to be mowing unevenly, a side to side adjustment can be performed. Adjust if necessary as follows:

- With the tractor parked on a firm, level surface, place the deck lift lever in the top notch (highest position) and rotate both blades so that they are perpendicular with the tractor.
- Measure the distance from the outside of the left blade tip to the ground and the distance from the outside of the right blade tip to the ground. Both measurements taken should be equal. If they're not, proceed to the next step.
- Loosen, but do NOT remove, the hex cap screw on the left deck hanger bracket. See Figure 10B.
- Balance the deck by using a wrench to turn the adjustment gear (found immediately behind the hex cap screw just loosened) clockwise/up or counterclockwise/down.
- The deck is properly balanced when both blade tip measurements taken earlier are equal.
- Retighten the hex cap screw on the left deck hanger bracket when proper adjustment is achieved.

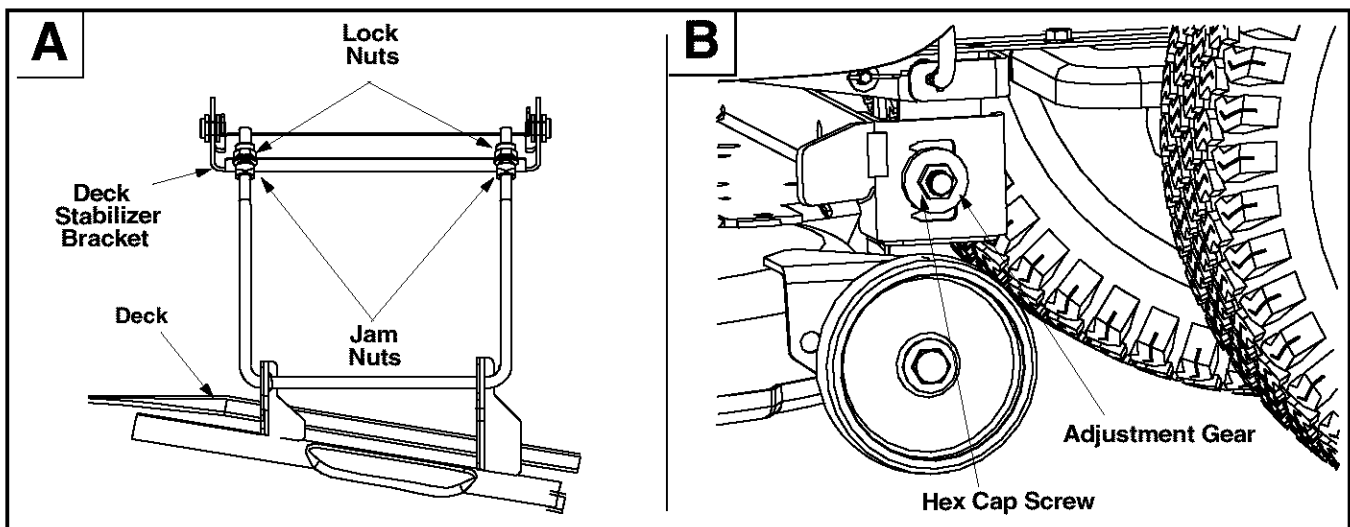

Figure 10

Deck Roller Height (Model 809K only)

To adjust the height of the rollers on the rear of the mowing deck, proceed as follows:

- Place the deck lift lever in the bottom notch (lowest position).
- Remove the clevis pins and hairpin clips from the deck roller brackets on the left and right sides of the cutting deck. See Figure 11.
- Position the deck roller brackets up or down through the slots on the rear of the deck until desired position is reached, then re-attach with the clevis pins and hairpin clips just removed. See Figure 11.

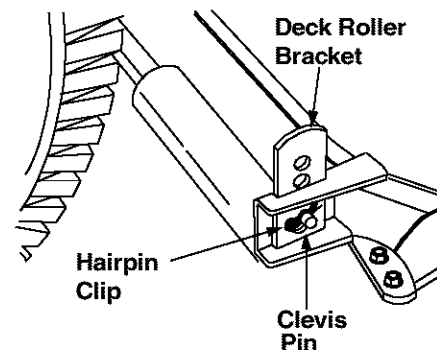

Figure 11

NOTE: Be certain that the left roller bracket and the right roller bracket are set in the same position

SECTION 7: MAINTAINING YOUR GARDEN TRACTOR



WARNING: Before performing any maintenance or repairs, disengage PTO, move shift lever into neutral position, set parking brake, stop engine and remove key to prevent unintended starting.

Engine

Refer to the engine manual for engine maintenance instructions.

- Check engine oil level before each use as instructed in the engine manual.

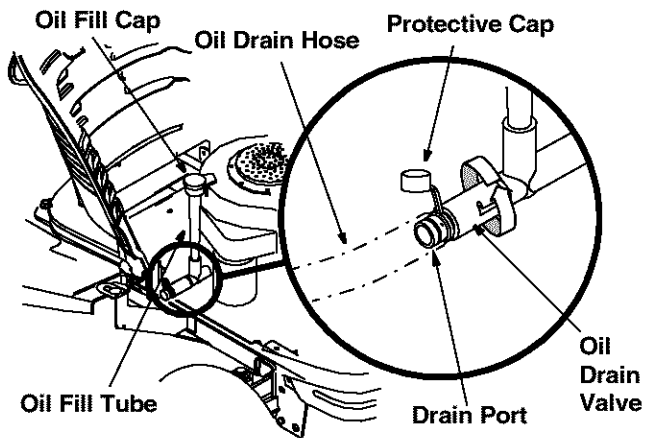

Figure 12

Changing Engine Oil

NOTE: Depending on the engine model found on your tractor, it may be necessary to remove the tractor's side panel in order to replace the oil filter (if so equipped).

- Unscrew oil fill cap and remove dipstick from the oil fill tube. See Figure 12.
- Pop open the protective cap on the end of the oil drain valve to expose the drain port. See Figure 12.
- Push the oil drain hose (packed with this manual) onto the oil drain port. Route the opposite end of the hose into an appropriate oil collection container with a capacity great enough to collect the used oil (approximately 64 oz.).
- Push the oil drain valve in slightly, then rotate counterclockwise and pull outward to begin draining oil. See Figure 12.
- Service the **oil filter** (if so equipped) as instructed in the engine manual.
- Perform the above steps in the opposite order after oil has finished draining.
- Refill the engine with new motor oil.

IMPORTANT: Refer to the engine manual for details about quantity and proper weight of motor oil.

Air Cleaner

- Service the pre-cleaner, if so equipped, and cartridge/air cleaner element as instructed in the engine manual.

Spark Plugs

- Clean the spark plugs and reset the gap once a season. Spark plug replacement is recommended at the start of each mowing season. Refer to the engine manual for correct plug type and gap specifications.

Cleaning the Engine and Deck

- Promptly wipe off any fuel or oil spilled on the machine.
- Do not allow grass, leaves, and dirt to accumulate around the cooling fins of the engine or on any other part of the machine, especially the pulleys and other moving parts.

IMPORTANT: The use of a pressure washer to clean your tractor is not recommended. Direct water pressure on electrical components and the engine could reduce life of the tractor and its serviceability.

Deck Wash System

Your tractor's deck is equipped with a water port on its surface as part of its deck wash system.

Use the Deck Wash System to rinse grass clippings from the deck's underside and prevent build-up of corrosive chemicals. Complete the following steps after each mowing:

- Drive the tractor to a level, clear spot on your lawn, near enough to a water sillcock (spigot) for your garden hose to reach.

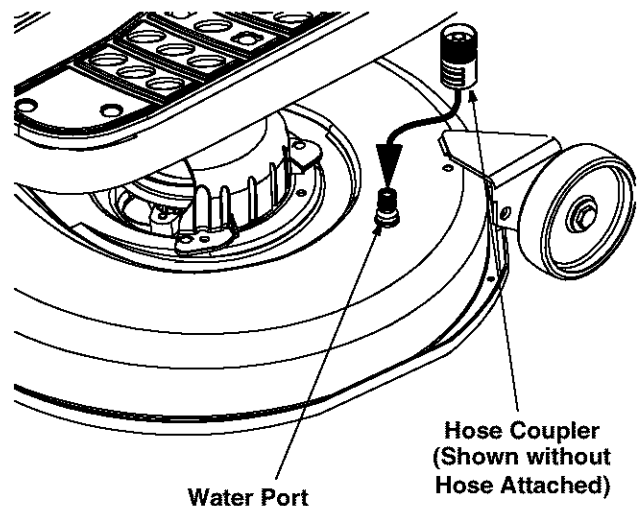

Figure 13

IMPORTANT: Make certain the tractor's discharge chute is directed away from your house, parked cars, etc.

- Disengage PTO, move shift lever into the neutral position, set the parking brake, and stop engine.
- Thread the hose coupler (packaged with this manual) onto the end of your garden hose.
- Attach the hose coupler to the water port on your decks surface. See Figure 13.
- Turn the water on.
- While sitting in the operator's position on the tractor, re-start the engine and place the throttle lever in the FAST (rabbit) position.
- Engage the tractor's PTO.
- **Remain in the operator's position** with the cutting deck engaged for a minimum of two minutes, allowing the underside of the cutting deck to thoroughly rinse.
- Disengage the tractor's PTO.
- Turn the ignition key to the STOP position to turn the tractor's engine off.
- Turn the water off and detach the hose coupler from the water port on your decks surface. Repeat step 4-11 on the opposite side of the cutting deck.

Lubrication



WARNING: Before lubricating, repairing, or inspecting, always disengage PTO, move shift lever into neutral position, set parking brake, stop engine and remove key to prevent unintended starting.

Engine

Lubricate the engine with motor oil as instructed in the *Briggs & Stratton Operator/Owner Manual* packed with your unit.

Pivot Points & Linkage

Lubricate all the pivot points on the drive system, parking brake and lift linkage at least once a season with light oil.

Front Wheels

Each end of the tractor's front pivot bar is equipped with a grease fitting. Lubricate with a grease gun after every 25 hours of tractor operation.

SECTION 8: SERVICE

Cutting Deck Removal

To remove the cutting deck, proceed as follows:

- Place the PTO knob in the disengaged (OFF) position and engage the parking brake.
- Lower the deck by moving the deck lift lever into the bottom notch on the right fender.
- Remove the PTO belt from around the electric PTO clutch. Refer to Figure 15.
- Looking at the cutting deck from the left side of the tractor, locate the deck support pin on the rear left side of the deck.
- Pull the deck support pin outward to release the deck from the deck lift arm. See Figure 14.

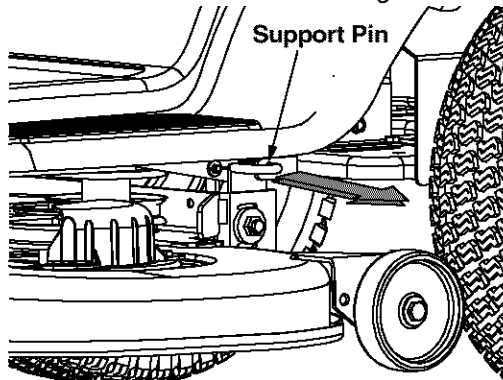

Figure 14

- Rotate the pin slightly toward the rear of the tractor and release the pin into the hole provided.
- Repeat the above steps on the tractor's right side.
- Move the deck lift lever into the top notch on the right fender to raise the deck lift arms up and out of the way.
- Gently slide the cutting deck toward the front of the tractor allowing the hooks on the deck to release themselves from the deck stabilizer rod.
- Gently slide the cutting deck (from the right side) out from underneath the tractor.

Changing the Deck Belt(s)



WARNING: Be sure to shut the engine off, remove ignition key, disconnect the spark plug wire(s) and ground against the engine to prevent unintended starting before removing the belt(s).

All belts on your tractor are subject to wear and should be replaced if any signs of wear are present.

IMPORTANT: The V-belts found on your tractor are specially designed to engage and disengage safely. A substitute (non-OEM) V-belt can be dangerous by not disengaging completely. For a proper working machine, use factory approved belts.

Model 809H

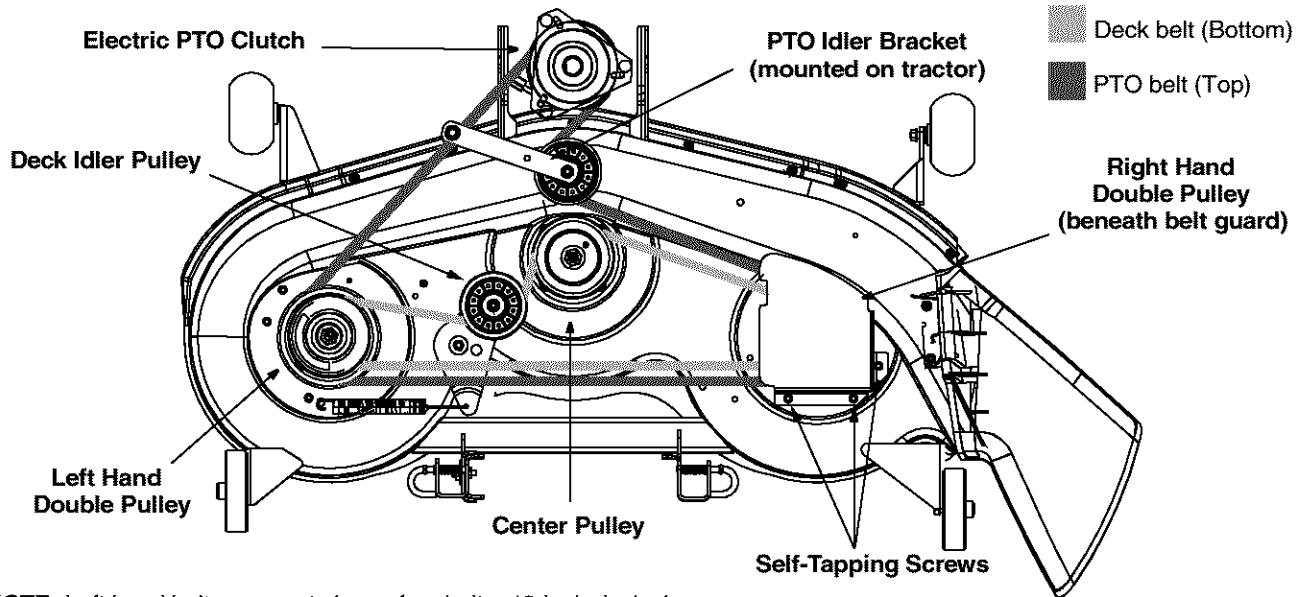

NOTE: Left hand belt cover not shown for clarity. 46-inch deck shown.

Figure 15

To change or replace the deck belts on your tractor, proceed as follows:

- Lower the deck by moving the deck lift lever into the bottom notch on the right fender.
- Remove the belt guards by removing the self-tapping screws that fasten them to the deck.
- **Model 809H only:** Grasp the PTO idler bracket and pivot it toward the discharge chute to relieve tension on the PTO belt.
- Remove the PTO belt from the electric PTO clutch and from around the PTO idler pulley, if present.
- Grasp the deck idler pulley and pivot it toward the left side of the deck to relieve tension on the belt.
- Remove the belt from around all spindle pulleys, and deck idler pulley(s).
- According to your tractor model, route the new belts as shown in Figure 16 or Figure 17.
- Remount the belt guards removed earlier.

Model 809K

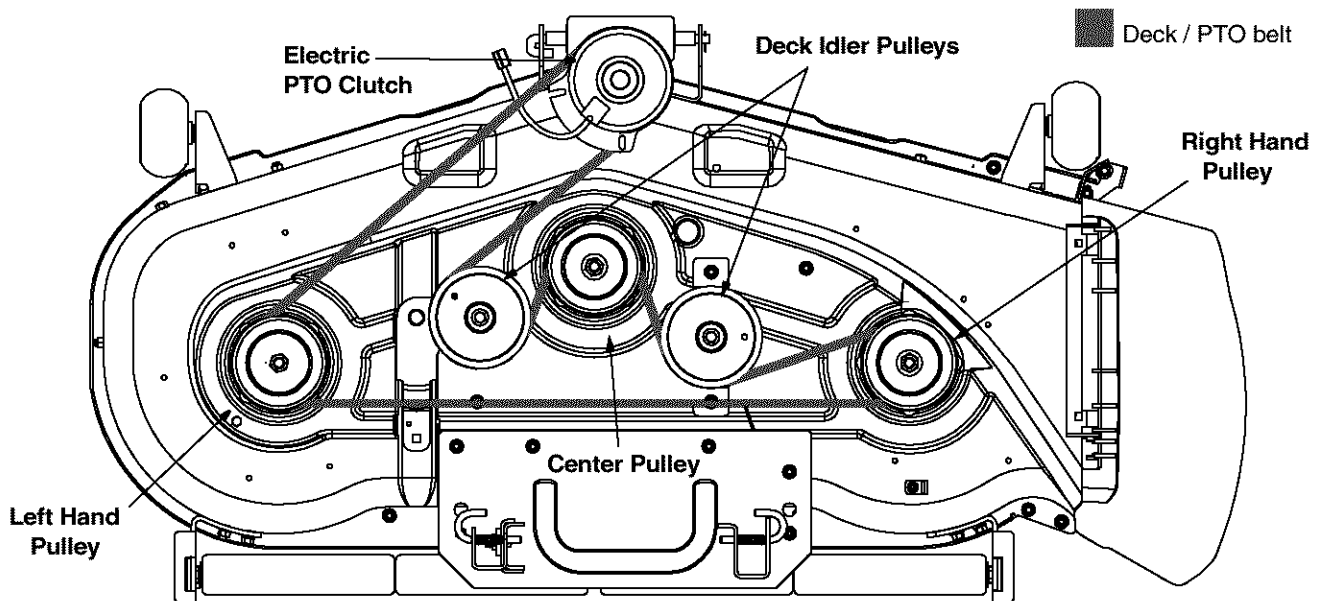

NOTE: Belt covers not shown for clarity. 54-inch deck shown.

Figure 16

Changing the Transmission Drive Belt



WARNING: Be sure to shut the engine off, remove ignition key, disconnect the spark plug wire(s) and ground against the engine to prevent unintended starting before removing the belt(s).

All belts on your tractor are subject to wear and should be replaced if any signs of damage are observed.

NOTE: It is recommended that both drive belts be replaced at the same time.

IMPORTANT: The V-belts found on your tractor are specially designed to engage and disengage safely. A substitute (non-OEM) V-belt can be dangerous by not disengaging completely. For a proper working machine, use factory approved belts.

To change or replace the drive belt on your tractor, proceed as follows:

- Remove the cutting deck as instructed earlier.
- After disconnecting the battery cables, remove the battery and battery tray from beneath the seat.

IMPORTANT: When removing the battery, disconnect the **negative** (black) wire from its terminal first, followed by the **positive** (red) wire. Re-install in reverse order.

Upper Drive Belt

- Locate the transmission idler pulley on the upper drive belt by looking through the battery tray opening. See Figure 17.
- Grasp the bracket and pivot the transmission idler pulley toward the rear of the tractor to release tension on the upper drive belt.
- Remove the belt from around the transmission idler pulley.
- Remove the upper drive belt from around the transmission pulley and the variable-speed pulley.

NOTE: Slowly rotate the pulley counter-clockwise to roll the belt off it.

- Remove the upper drive belt by pulling it up through the battery tray opening.
- Reroute the new upper drive belt as shown in Figure 17.

Lower Drive Belt

NOTE: Proper removal of the lower drive belt requires the removal of several tractor components. Read through the following procedure prior to attempting it; determine if you can successfully complete it. Otherwise, see an authorized Troy-Bilt Service Dealer for the job.

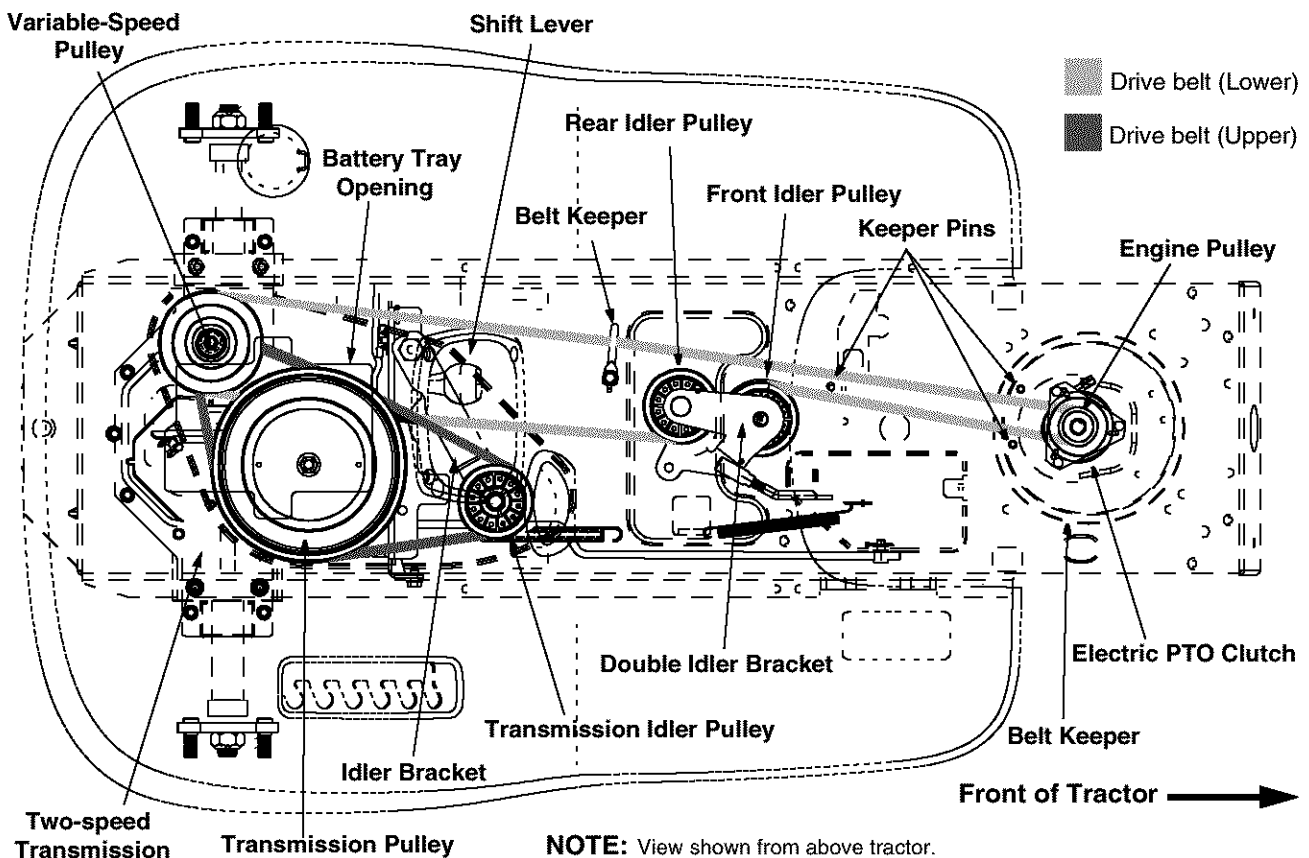

Figure 17

IMPORTANT: Note the routing of the lower drive belt around both the pulleys and the belt keepers before performing the following steps.

- Locate the variable-speed pulley through the battery tray opening. See Figure 17.
- Remove the variable-speed pulley by loosening the hex bolt that secures it to the transmission. Use a second wrench to hold the hex nut on the bottom side of the pulley.
- Slide the belt off the variable-speed pulley as you lift the pulley up and out through the battery tray opening.
- Remove rear idler pulley from the double-idler bracket while loosening the belt from around both the rear and the front idler pulleys. See Figure 17.
- Remove the hex bolt from the center of the electric PTO clutch and gently lower it off the engine crankshaft. Be careful not to lose any washers or which may be found on top of the PTO clutch.

IMPORTANT: When remounting the PTO clutch, torque the center hex bolt to between 38 foot-pounds and 50 foot-pounds.

- Remove the drive belt by feeding it from both ends toward the front idler pulley on the double-idler bracket. See Figure 18.

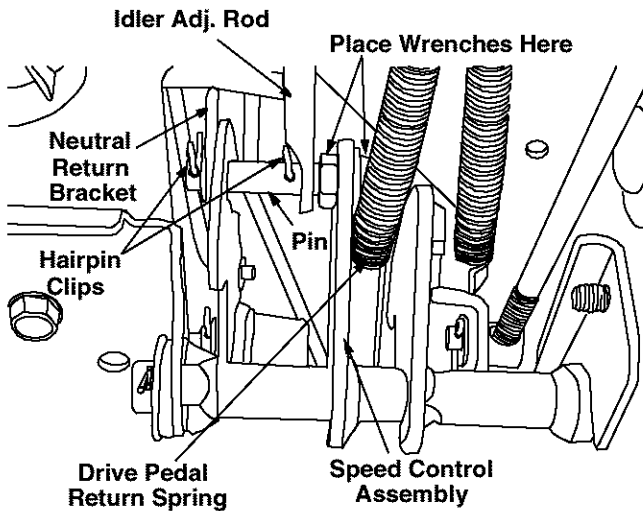
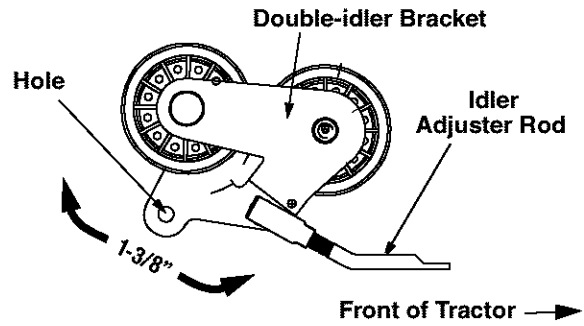

Figure 18

- Reassemble by following the above steps in reverse order.
- Reroute the new belt around the pulleys, belt keepers and keeper pins exactly as the old one was routed. Refer to Figure 17.

The drive pedal is properly adjusted when the hole found in the double-idler bracket has approximately 1-3/8" of travel with ten pounds of pressure applied to the drive pedal. See Figure 19.



NOTE: View shown from above tractor.

Figure 19

Adjust the drive pedal after replacing the drive belts on your tractor, if necessary, as follows:

- Locate the speed control assembly on the underside of the steering support bracket. See Figure 18.
- Remove both hairpin clips from the pin which is fastened to the speed control assembly (be careful not to lose the small flat washers found on the pin). See Figure 18.
- Remove the drive pedal return spring.
- Using two 9/16" wrenches, remove the pin from the speed control assembly. See Figure 18.
- Thread the idler adjustment rod inward or outward to lengthen or shorten the travel of the double-idler bracket until proper adjustment is achieved.
- Reassemble by following the above steps in reverse order.

Tires



WARNING: Never exceed the maximum inflation pressure shown on the tire sidewall.

Refer to the tire sidewall for exact tire manufacturer's recommended or maximum psi. Do not overinflate. Uneven tire pressure could cause the cutting deck to mow unevenly.

Cutting Blades



WARNING: Be sure to shut the engine off, remove ignition key, disconnect the spark plug wire(s) and ground against the engine to prevent unintended starting before removing the cutting blade(s) for sharpening or replacement. Protect your hands by using heavy gloves or a rag to grasp the cutting blade.

- Periodically inspect the blade adapter and/or spindle for cracks or damage, especially if you strike a foreign object. Replace immediately if damaged.

The blades may be removed as follows:

- Remove the deck from beneath the tractor, (refer to **Cutting Deck Removal** on page 19) then gently flip the deck over to expose its underside.
- Place a block of wood between the center deck housing baffle and the cutting blade to act as a stabilizer. See Figure 20.

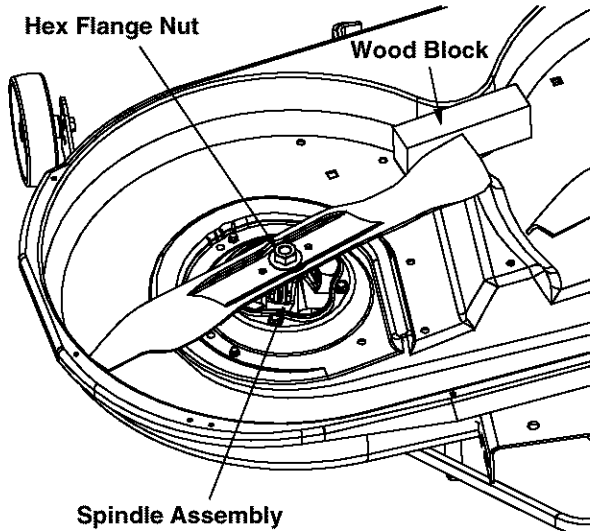

Figure 20

- Use a 15/16" wrench to remove the hex flange nut that secures the blade to the spindle assembly. See Figure 20.
- To properly sharpen the cutting blades, remove equal amounts of metal from both ends of the blades along the cutting edges, parallel to the trailing edge, at a 25° to 30° angle. See Figure 21.

IMPORTANT: If the cutting edge of the blade has already been sharpened to within 5/8" of the wind wing radius, or if any metal separation is present, replace the blades. See Figure 21.

- Grind each cutting blade edge equally to maintain proper blade balance.



WARNING: A poorly balanced blade will cause excessive vibration, may damage the tractor and cause personal injury.

- Test the blade by balancing it on a round shaft screwdriver. Grind metal from the heavy side until it balances evenly.
- When replacing the blade, be sure to install the blade with the side of the blade marked "Bottom" (or with a part number stamped in it) facing the ground when the mower is in the operating position.

IMPORTANT: Use a torque wrench to tighten the blade spindle hex flange nut to between 70 foot-pounds and 90 foot-pounds.

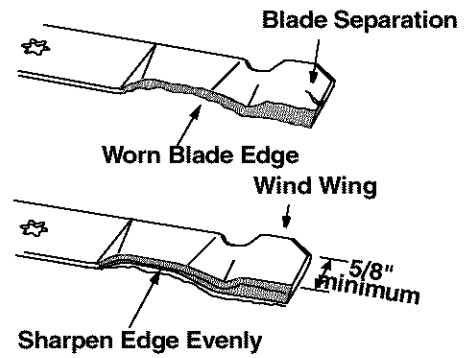

Figure 21



WARNING: Before servicing, repairing, or inspecting, always disengage PTO, move shift lever into neutral position, set parking brake, stop engine and remove key to prevent unintended starting.

Fuses

Two fuses are installed in your tractor's wiring harness to protect the tractor's electrical system from damage caused by excessive amperage.

- If the electrical system does not function, or your tractor's engine will not crank, first check to be certain that the fuse has not blown. One fuse is located under the hood mounted behind the top of the dash panel on the support bar. The other can be found under the seat mounted to the inside of the tractor frame next to the battery tray. Pull the fuse out and inspect it to determine if it is good or blown. Replace if necessary.

IMPORTANT: Always use a fuse with the same amperage capacity for replacement.

Battery

The battery is sealed and is maintenance-free. Acid levels cannot be checked.

- Always keep the battery cables and terminals clean and free of corrosive build-up.
- After cleaning the battery and terminals, apply a light coat of petroleum jelly or grease to both terminals.

IMPORTANT: Always keep the rubber boot positioned over the positive terminal to prevent shorting.

IMPORTANT: If removing the battery for any reason, disconnect the **negative** (black) wire from its terminal first, followed by the **positive** (red) wire. When re-installing the battery, always connect the **positive** (red) wire its terminal first, followed by the **negative** (black) wire. Be certain that the wires are connected to the correct terminals; reversing them could change polarity and damage the engine's alternating system.

Charging

If the tractor has not been put into use for an extended period of time, charge the battery with an automotive-type 12-volt charger for a minimum one hour at 6 amps.



WARNING: Batteries give off an explosive gas while charging. Charge battery in a well ventilated area and keep away from an open flame or pilot light as on a water heater, space heater, furnace, clothes dryer or other gas appliances.

SECTION 9: OFF-SEASON STORAGE

Clean and lubricate the tractor as instructed on page 18 of this manual before storing for an extended period.



WARNING: Drain fuel only into an approved container outdoors, away from an open flame. Allow engine to cool. Extinguish cigarettes, cigars, pipes, and other sources of ignition prior to draining fuel.

Follow the instructions in the service, storage & specifications section of the engine manual for proper engine care prior to storing your tractor.



WARNING: Never store the machine or fuel container indoors where there is an open flame, spark or pilot light such as on water heater, furnace, clothes dryer or other gas appliance.

SECTION 10: ATTACHMENTS & ACCESSORIES

The following attachments and accessories are compatible for tractor **Models Z809H & Z809K**. See the retailer from which you purchased your tractor or phone (866) 840-6483 for information regarding price and availability.

MODEL	DESCRIPTION
OEM-190-118	Mulch Kit (For 46-inch Decks Only)
OEM-190-603	FastAttach™ Grille Guard (mounts on front of tractor)
OEM-190-604	FastAttach™ Yard-Mate™ Storage Container/Toolbox (mounts on rear of tractor)
OEM-190-607	FastAttach™ Deluxe Tractor Sunshade
OEM-190-608	FastAttach™ Sleeve Hitch, Manual Lift
OEM-190-821	FastAttach™ Triple Bagger Grass Collector (For 46-inch Decks Only)
OEM-190-822	FastAttach™ 46-inch Front Dozer Blade
OEM-190-823	42-inch Two-stage Snowthrower
OEM-190-824	Sleeve Hitch with Electric Lift
OEM-190-841	Mulch Kit (For 54-inch Decks Only)
OEM-190-842	FastAttach™ Triple Bagger Grass Collector (For 54-inch Decks Only)
SLEEVE HITCH ATTACHMENTS (For use with OEM-190-824 or OEM-190-608)	
OEM-190-825	30-inch Hydraulic Tiller†
OEM-190-984	Row Crop Cultivator
OEM-190-980	Single-disc Harrow
OEM-190-978	10-inch Mulboard Plow
OEM-190-804	42-inch Heavy Duty Rear Blade

† OEM-190-824 is required for use of this attachment. OEM-190-608 **cannot** be used in its place.

SECTION 11: TROUBLESHOOTING

Trouble	Possible Cause(s)	Corrective Action
Engine fails to start	PTO knob engaged. Parking brake not engaged. Spark plug wire(s) disconnected. Throttle control lever not in correct starting position. Choke not activated Fuel tank empty, or stale fuel. Blocked fuel line. Faulty spark plug. Engine flooded.	Place PTO knob in disengaged (OFF) position. Engage parking brake. Connect wire(s) to spark plug. Place throttle lever to FAST position. Pull out the CHOKE control (if so equipped). Fill tank with clean, fresh (less than 30 days old) gas. Clean fuel line or replace fuel filter, if so equipped. Clean, adjust gap or replace plug. Crank engine with throttle in FAST position.
Engine runs erratic	Unit running with CHOKE applied. Spark plug wire(s) loose. Blocked fuel line or stale fuel. Vent in gas cap plugged. Water or dirt in fuel system. Dirty air cleaner.	Push CHOKE control (if so equipped) in. Connect and tighten spark plug wire(s). Clean fuel line; fill tank with clean, fresh (less than 30 days old) gasoline. Replace fuel filter, if so equipped. Clear vent or replace cap if damaged. Drain fuel tank. Refill with clean, fresh (less than 30 days old) gasoline. Replace air cleaner cartridge/element or clean pre-cleaner, if so equipped.
Engine overheats	Engine oil level low. Air flow restricted.	Fill crankcase with proper capacity and weight of oil. Clean grass clippings and debris from around the engine's cooling fins and blower housing.
Engine hesitates at high RPM	Spark plug(s) gap too close.	Remove spark plug(s) and reset the gap to .030" .
Idles poorly	Spark plug(s) fouled, faulty or gap too wide. Dirty air cleaner.	Replace spark plug(s). Set plug(s) gap to .030" . Replace air cleaner cartridge/element or clean pre-cleaner, if so equipped.
Excessive vibration	Cutting blade loose or unbalanced. Damaged or bent cutting blade.	Tighten blade and spindle. Balance blade. Replace blade.
Mower will not mulch grass	Engine speed too low. Wet grass. Excessively high grass. Dull blade.	Place throttle in FAST (rabbit) position. Do not mow when grass is wet; wait until later to cut. Mow once at a high cutting height, then mow again at desired height or make a narrower cutting swath. Sharpen or replace blade.
Uneven cut	Deck not balanced properly. Dull blade. Uneven tire pressure.	Perform side-to-side deck adjustment. Sharpen or replace blade. Check tire pressure in all four tires.

SECTION 12: PARTS LIST FOR MODELS Z809H & Z809K

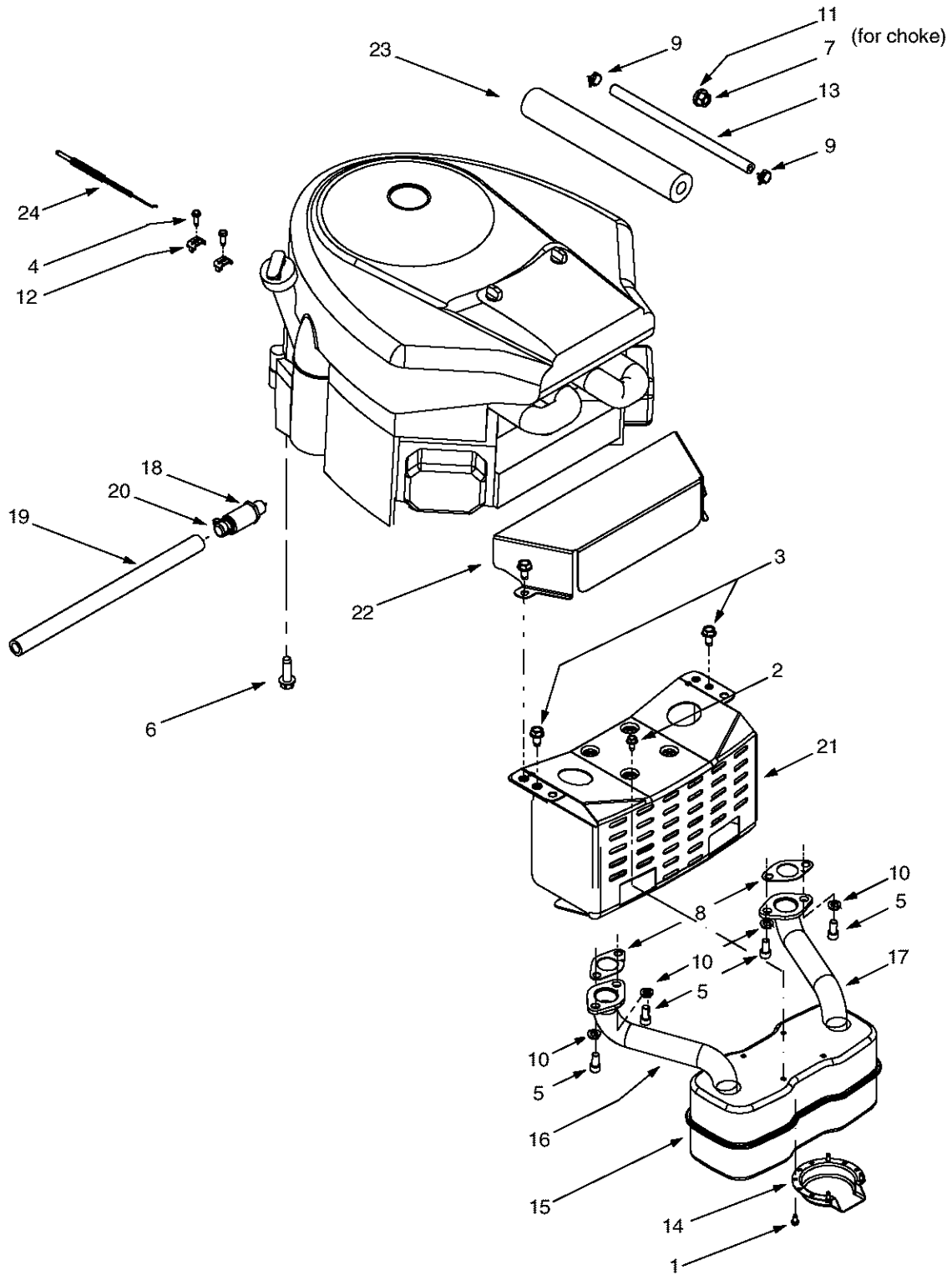

Models Z809H & Z809K

REF. NO.	PART NO.	DESCRIPTION
1	710-0227	Self-tapping Screw, #8-18 x .5
2	710-0599	Self-tapping Screw, 1/4-20 x .5
3	710-0726	AB Screw, 5/16-12 x .75
4	710-1237	Screw, #10-32 x .625
5	710-1314A	Socket Cap Screw, 5/16-18 x .625
6	710-1315	Self-tapping Screw, 3/8-16 x 1.25
7	712-3017	Hex Nut, 3/8-16
8	721-0460	Exhaust Gasket
9	726-0205	Hose Clamp
10	736-0119	Lock Washer, 5/16
11	736-0300	Flat Washer
12	751B221535	Casing Clamp
13	751-0535	Fuel Line Hose
14	751-0564	Muffler Deflector
15	751-0616	Muffler, Twin Inlet
16	751-0650	RH Exhaust Pipe
17	751-0651	LH Exhaust Pipe
18	751-3140	Oil Drain Valve
19	751-3141	Oil Drain Hose
20	751-3142	Oil Drain Cap
21	783-0615B	Muffler Heat Shield
22	783-0625C	Engine Heat Shield
23	722-0263	Foam (fits over fuel line)
24	746-1086	Throttle Cable

Models Z809H & Z809K

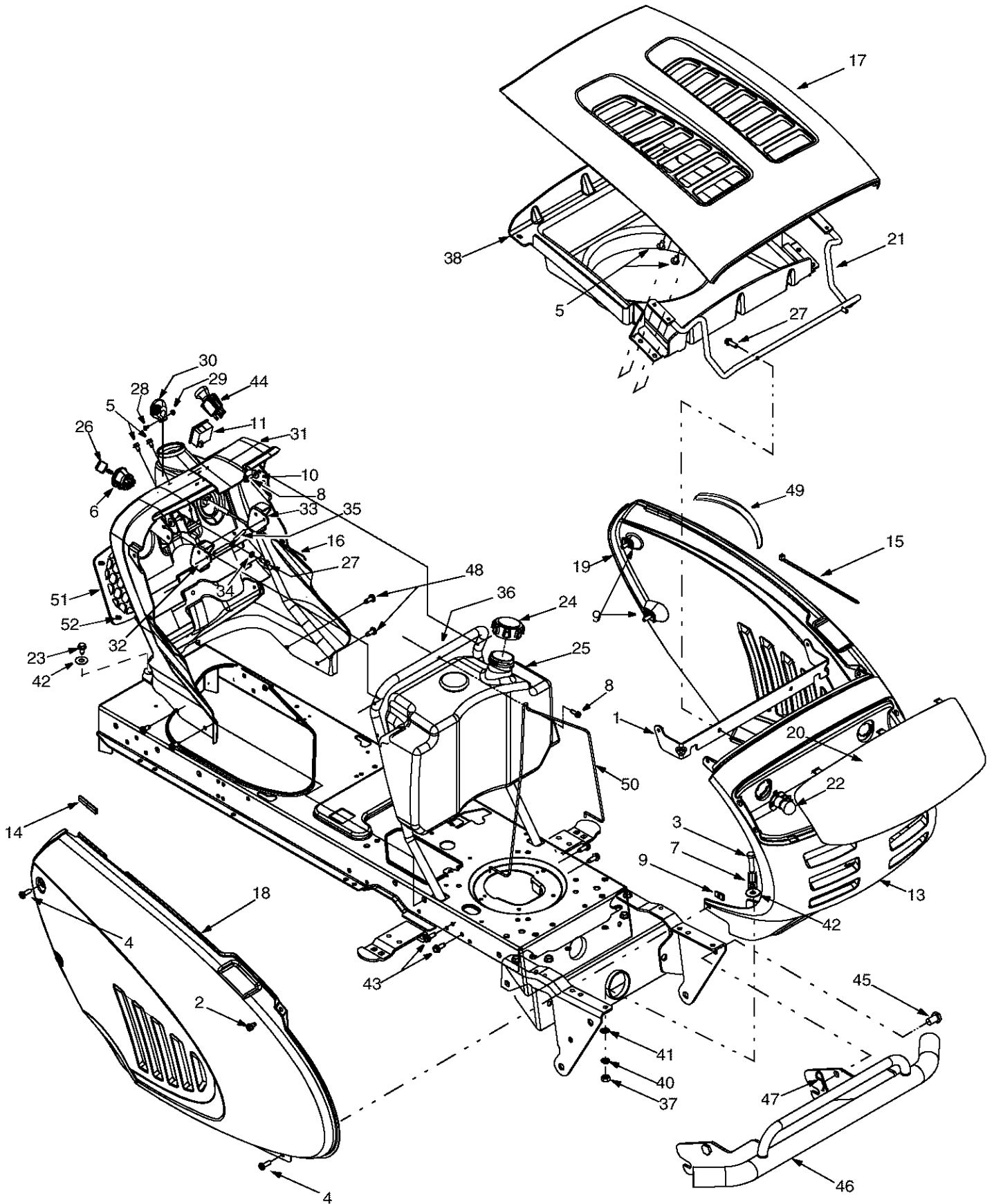

Models Z809H & Z809K

REF. NO.	PART NO.	DESCRIPTION
1	783-1346	Grill Support Bracket (9-style)
2	710-0599	Self-tapping Screw, 1/4-20 x .5
3	710-0528	Hex Cap Screw, 5/16-18 x 1.25
4	710-0924	Phillips Pan Screw, 1/4-20 x .75
5	710-1017	Truss Phillips Screw, 1/4-20 x .625
6	725-1741	Ignition Switch
7	726-0272	Clamp, 9/16
8	710-0642	Self-tapping Screw, 1/4-20 x .75
9	712-0292	U-type Speed Nut, 1/4-20
10	736-0270	Bell Washer, .265 x .75 x .062
11	725-1976	Systems Indicator Monitor
12	712-3004A	Hex Nut, 5/16-18
13	731-2119A	Grille (9-style)
14	731-0511	Trim Strip, 4
15	725-0175	Cable Tie, 3/16 x .05 x 7.4
16	746-1085	Choke Knob/Cable
17	783-0783	Hood (9-style)
18	783-0784	RH Side Panel
19	783-04200	LH Side Panel
20	731-2637	Headlight Lens
21	747-2138	Hood Hinge Rod
22	625-0051	Headlight Assembly
23	710-0726	AB Screw, 5/16-12 x .75
24	751-0603	Fuel Cap
25	751-3213	Fuel Tank, 3 gallon
26	725-1745	Ignition Key w/ plastic cover
	725-1744	Ignition Key w/o plastic cover
27	710-0895	Self-tapping Screw, 1/4-15 x .75
28	710-3217	Truss Phillips Screw, #8-32 x .375
29	712-0142	Hex Nut, #8-32
30	731-1857	Throttle Control Knob
31	731-2225C	Dash Panel, 8/9-style, Electric PTO
32	731-04215	Cruise Control Button
33	731-04217	Parking Brake Button
34	736-0142	Flat Washer, 9/32 x 1/2 x 1/16
35	747-1196	Brake/Cruise Pivot Rod
36	749-1087C	Dash Support Tube
37	712-3010	Hex Nut, 5/16-18
38	731-2270	Hood Plenum*
39	726-3046	Ratchet Clip
40	736-0119	Lock Washer, 5/16
41	726-0201	Speed Nut, .3125
42	736-3078	Flat Washer, .349 x 1.0 x .063
43	710-0650	TT Screw, 5/16-18 x .875
44	725-1752	Electric PTO Switch
45	711-0332	Clevis Pin, .50 x .78
46	768-0010	Bumper Assembly
47	714-0145	Internal Cotter Pin
48	710-1611B	TT Screw 5/16-18 x 0.75
49	735-04019	Seal: Panel
50	747-04132	Tank Support Rod
51	735-04023	Cargo Net
52	726-3046	Ratchet Clip
—	629-0469A	Headlight Wire Harness
—	629-1067	Tractor Wire Harness

*Not standard on all tractors.

Models Z809H & Z809K

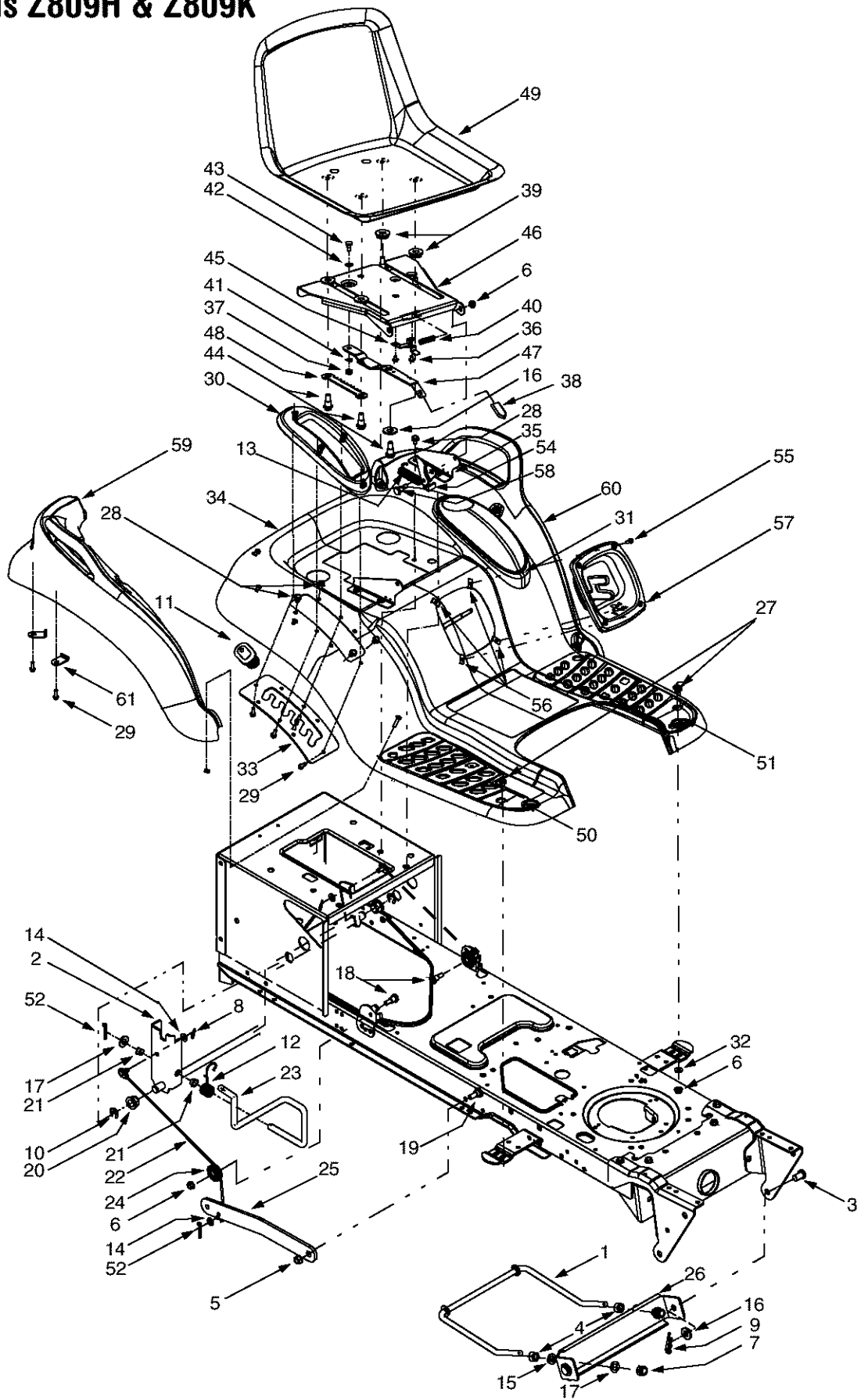

Models Z809H & Z809K

REF. NO.	PART NO.	DESCRIPTION	REF. NO.	PART NO.	DESCRIPTION
1	747-1130B	Deck Stabilizer Rod (Model Z809H)	31	731-1993	Cover w/ Cup Holder
	747-1324	Deck Stabilizer Rod (Model Z809K)	32	736-3078	Flat Washer, .349 x 1.0 x .063
2	683-0197B	Lift Shaft Assembly (Model Z809H)	33	783-0677	Lift Adjustment Bracket
	683-0462	Lift Shaft Assembly (Model Z809K)	34	783-1280	Fender
3	711-0332	Clevis Pin, .5 x .78	35	783-1489	Seat Mounting Bracket
4	712-0206	Hex Nut, 1/2-13	36	710-1268	Screw, #10-16 x .375
5	712-0431	Flange Lock Nut, 3/8-16	37	712-3027	Hex Flange Lock Nut, 1/4-20
6	712-3004A	Flange Lock Nut, 5/16-18	38	720-0309A	Seat Adjuster Grip
7	712-3083	Hex Nut, 1/2-13	39	731-1989	Spacer
8	714-0104	Internal Cotter Pin	40	732-0499	Compression Spring, .41 x 1.5
9	714-0145	Internal Cotter Pin	41	736-0175	Spring Washer, .265 x .562 x .025
10	716-0106	E-Ring	42	736-0204	Flat Washer, .344 x .62 x .03
11	720-0311	Handle Grip	43	738-0137A	Shoulder Screw, .340 x .285, 1/4-20
12	732-0874	Torsion Spring	44	738-1007	Shoulder Screw, .50 x .50, 3/8-16
13	732-1184	Extension Spring, .84 x 4.6	45	783-0611	Seat Stop
14	736-0275	Flat Washer, 5/16	46	783-0738	Seat Pivot Bracket
15	736-0921	Lock Washer, 1/2	47	783-0739	Seat Adjustment Lever
16	736-3019	Flat Washer, .31 x 1.062 x .134	48	783-0753	Seat Adjustment Selector
17	736-3084	Flat Washer, .51 x 1.12 x .06	49	757-04010	High Back Seat, Black
18	738-0138A	Hex Cap Screw, 5/16-18 x .62	50	735-0656	RH Foot Pad
19	738-0143	Shoulder Screw, 3/8-16	51	735-0657	LH Foot Pad
20	741-0225	Hex Flange Bearing	—	726-3046	Foot Pad Clips
21	741-0715	Snap Flange Bearing	52	714-0111	Cotter Pin
22	746-0968	Lift Cable, 16.16	54	783-0209A	LH Seat Lift Bracket
23	747-1111A	Lift Handle	—	17239A	RH Seat Lift Bracket
24	756-1154	Roller Pulley	55	710-0924	Phillips Pan Screw, 1/4-20 x .75
25	783-0678A	Arm Lift	56	712-0292	U-type Speed Nut, 1/4-20
26	783-0720A	Deck Stabilizer Bracket	57	731-2480	Shift Lever Cover
27	710-0260A	Carriage Bolt, 5/16 x .62	58	738-0296	Shoulder Screw, .437 x .286
28	710-0726	AB Screw, 5/16-12 x .75	59	731-2618	RH Fender Flare
29	710-0895	Self-tapping Screw, 1/4-15 x .75	60	731-2619	LH Fender Flare
30	731-1990	Lift Lever Cover	61	783-1478	Fender Clips

NOTE: For **paint**ed parts, please refer to the list of color codes below. Please add the applicable color code, wherever needed, to the part number to order a replacement part. For instance, if a part numbered 700-xxxx is painted Powder Black, the part number to order would be 700-xxxx-0637.

Red: 0638

Oyster Gray: 0662

Powder Black: 0637

Models Z809H & Z809K

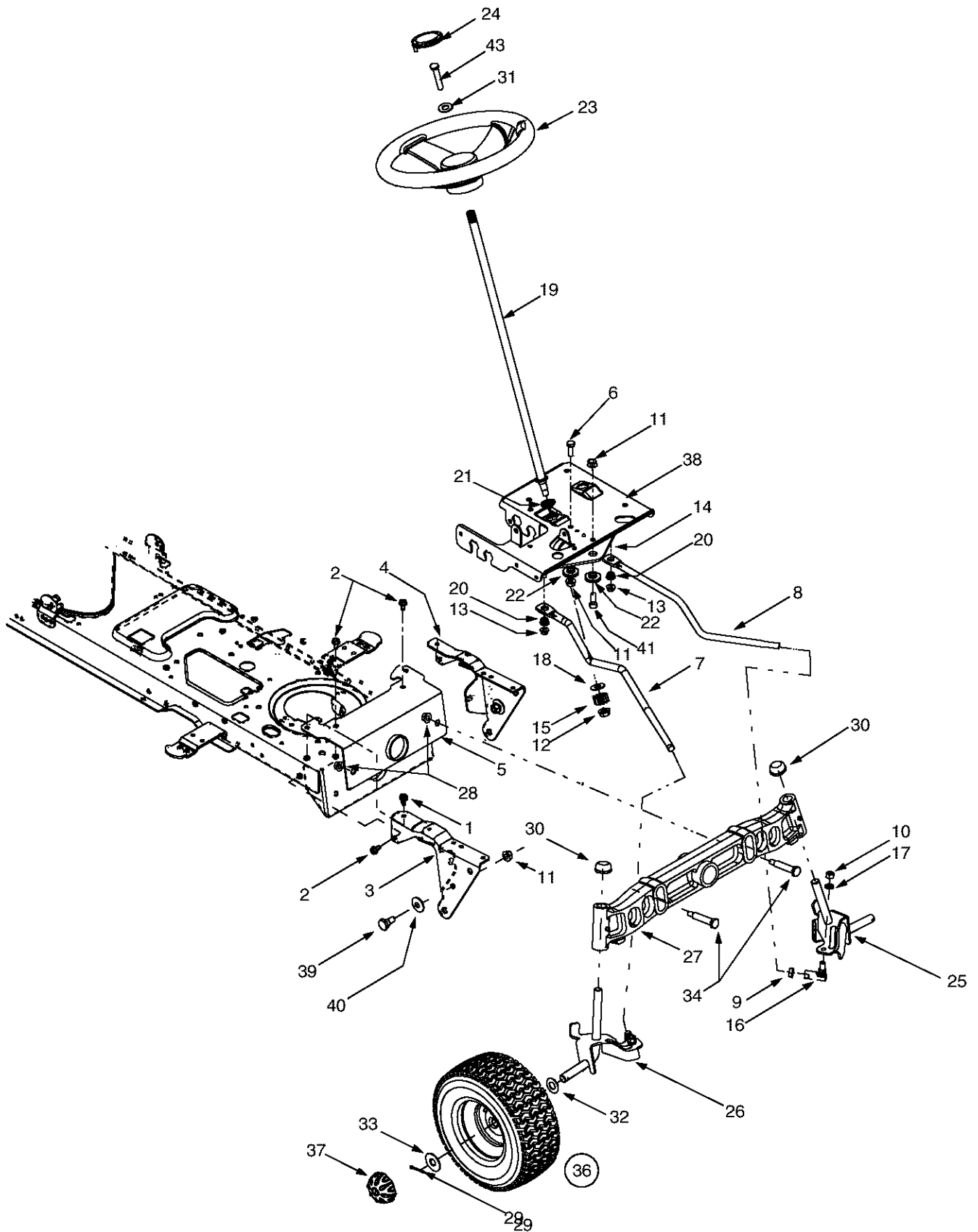

Models Z809H & Z809K

REF. NO.	PART NO.	DESCRIPTION
1	710-1260A	Self-tapping Screw, 5/16-18 x .75
2	710-0604A	Self-tapping Screw, 16-18 x .625
3	783-0726B	RH Pivot Support Bracket
4	783-0727A	LH Pivot Support Bracket
5	783-0728	Pivot Bar Bracket
6	710-0514	Hex Cap Screw, 3/8-16 x 1 (Grade 5)
7	711-1408	RH Drag Link
8	711-1409A	LH Drag Link
9	712-0240	Jam Nut, 7/16-20 (Grade 2)
10	712-0241	Hex Nut, 3/8-24 (Grade 2)
11	712-0431	Flange Lock Nut, 3/8-16
12	712-0459	Flange Lock Nut, 7/16-20
13	712-3004A	Flange Lock Nut, 5/16-18
14	717-1550D	Steering Gear, 11/90 Ratio
15	717-1554	Steering Pinion Gear
16	723-0448A	Ball Joint, 7/16-20
17	736-0169	Lock Washer, 3/8
18	736-3084	Flat Washer, .51 x 1.12 x .06
19	738-1001A	Steering Shaft, .625 OD x 24.4
20	741-0475	Plastic Bushing, .38 ID
21	741-0656	Hex Flange Bearing, 5/8
22	738-0372B	Shoulder Spacer, .38 ID
23	731-2624	Steering Wheel, Soft Grip, Three Spoke
24	731-2625	Steering Wheel Cap, Round
25	638-0017	LH Axle Assembly, .75 Diameter
26	638-0018	RH Axle Assembly, .75 Diameter
27	719-0525B	Cast Iron Pivot Bar w/ Fittings, .75
28	712-0431	Flange Lock Nut, 3/8-16
29	714-0162	Cotter Pin
30	726-0341	Push Cap, .750
31	736-0242	Bell Washer, .34 x .872
32	736-0316	Flat Washer, .78 x 1.59 x .06
33	736-0285	Flat Washer, .635 x 1.589 x .06
34	738-1011	Shoulder Screw, .5 x 2.2, 3/8-16
35	710-0643	Hex Bolt, 5/16-18 X 1
36	634-0183	Wheel Assembly Complete, 16 x 6.5 x 8
	634-0182	Rim Only w/ Plastic Bearing
	734-0255	Air Valve (Not Shown)
	734-1727	Tire Only, Square Shoulder
37	734-2290	Hub Cap
38	783-0653E	Steering Support Bracket
39	738-0143	Shoulder Screw, 3/8-16
40	736-0331	Bell Washer, .39 x 1.13 x .062
41	710-04095	Hex Bolt 3/8-16 x 1.0 Special

NOTE: For **painted parts**, please refer to the list of color codes below. Please add the applicable color code, wherever needed, to the part number to order a replacement part. For instance, if a part numbered 700-xxxx is painted Powder Black, the part number to order would be 700-xxxx-0637.

Red: 0638

Oyster Gray: 0662

Powder Black: 0637

Models Z809H & Z809K

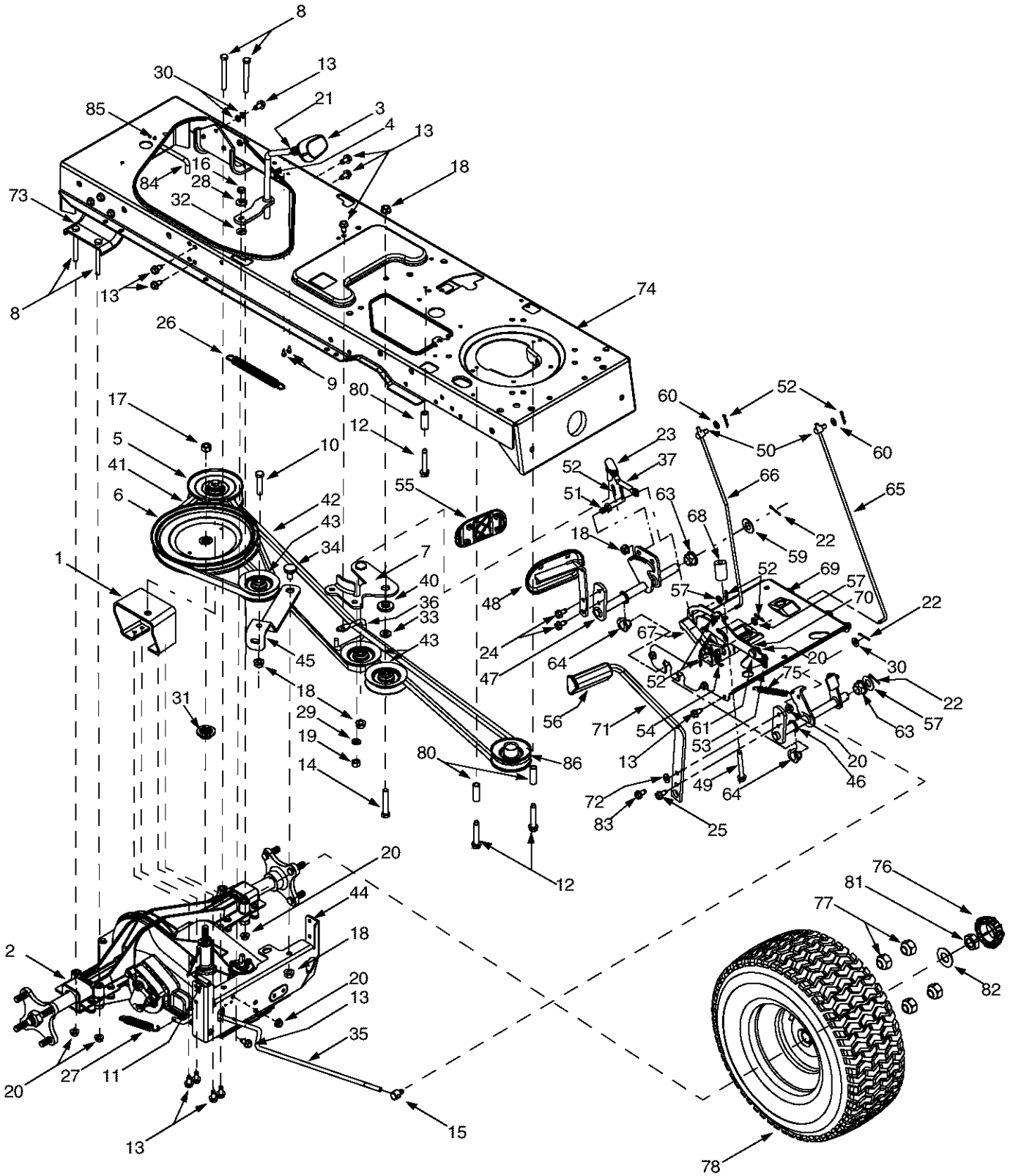

Models Z809H & Z809K

REF. NO.	PART NO.	DESCRIPTION	REF. NO.	PART NO.	DESCRIPTION
1	618-0375	Variable-speed Bracket Assembly	45	783-0669	Idler Bracket
2	618-0376	Two-speed Transmission Assembly	46	647-0031B	Brake Control Shaft Assembly
3	631-0009A	Shifter Knob	47	647-0032	Speed Control Shaft Assembly
4	647-0037	Shift Lever	48	683-0266	Drive Pedal Assembly
5	656-0050	Variable-speed Pulley Assembly	49	710-1135	Self Tapping Screw, 5/16-18 x 2.5
6	756-0665	Transmission Pulley, 8.5	50	711-0736	Ferrule, 1/4-20
7	683-0251	Double-Idler Bracket	51	711-1363	Pin, 3/8-16 x 2.43
8	710-0176	Hex Cap Screw, 5/16-18 x 2.75	52	714-0104	Cotter Pin
9	710-0227	Self Tapping Screw, #8-18 x .5	53	732-0437	Compression Spring, .34 OD x 1.0
10	710-0347	Hex Cap Screw, 3/8-16 x 1.75	54	732-0955	Extension Spring, .5 OD x 1.41
11	710-0805	Hex Cap Screw, 5/16-18 x 1.5	55	735-0662	Drive Pedal Pad
12	710-0809	Self-tapping Screw, 1/4-20 x 1.25	56	735-3049	Brake Pedal Pad
13	710-0726	AB Screw, 5/16-12 x .75	57	736-0140	Flat Washer, .281 x .5 x .0625
14	710-3011	Hex Cap Screw, 3/8-16 x 2.25	59	736-0187	Flat Washer, .64 x 1.24 x .06
15	711-0677	Ferrule, 5/16 x .312 Dia.	60	736-0204	Flat Washer, .344 x .062 x .03
16	712-0181	Hex Jam Nut, 3/8-16	61	738-0155	Shoulder Screw, .437 x 1.62
17	712-0702	Hex Flange Nut, 7/16-20	62	738-0507B	Shoulder Screw, .5 x .434
18	712-0431	Flange Lock Nut, 3/8-16	63	741-0225	Hex Flange Bearing
19	712-0798	Hex Nut, 3/8-16	64	741-3065B	Split Hex Flange Bearing
20	712-3004A	Flange Lock Nut, 5/16-18	65	747-04096	Cruise Control Rod
21	712-3008	Hex Jam Nut, 3/8-16	66	747-04093	Brake Lock Control Rod
22	714-0111	Cotter Pin	67	748-0413	Cruise Latch
23	723-3018	Ball Joint, 3/8-24	68	748-0415B	Spacer, 5/16 x 1.54
24	710-1260A	LD Screw 5/16-18 x 0.75	69	783-0653F	Steering Support Bracket
25	710-0650	TT Screw 5/16-18 x 0.875	70	783-0732	Drive Lockout Bracket
26	732-0384	Extension Spring, .62 Dia. x 6.12	71	783-0773	Brake Pedal
27	732-0716	Extension Spring, .59 OD x 4.0	72	736-3008	Flat Washer, .344 x .750 x .120
28	736-0105	Bell Washer, .401 x .870 x .063	73	783-0693	Axle Bracket
29	736-0169	Lock Washer, 3/8	74	683-0304A	Lower Frame Assembly
30	736-0275	Flat Washer, 5/16	75	732-0963	Extension Spring, .5 OD x 6.37
31	718-0771	Pulley Hub, 1/2 Spline	76	731-2290	Hub Cap
32	736-0642	Flat Washer, .44 x .75 x .06	77	712-3050	Lug Nut, 7/16-14
33	736-3010	Flat Washer, .407 x .812 x .135	78	634-0132	Wheel Assembly Complete, 23 x 9.5 x 12
34	738-0322	Shoulder Screw, .625 Dia. x .21		634-0182	Rim Only
35	747-1122	Brake Rod		734-0255	Air Valve
36	747-1123A	Belt Guard		734-1728	Tire Only, Square Shoulder
37	747-1127	Idler Adjustment Rod, 3/8	79	750-0768	Split Spacer, .25 x .37 x 1.32
38	710-1026	Self-tapping Screw, 1/4-20 x 1.75	80	750-0566A	Spacer, .372 x .26 x 1.03
39	747-1185	Transmission Belt Guard Rod	81	712-3026	Jam Nut, 3/4-16
40	738-0372B	Shoulder Spacer, .380 ID	82	736-0316	Flat Washer, .78 x 1.59 x .06
41	754-0468	Variable-speed Belt	83	710-1611B	TT Screw, 5/16-18 x .75
42	754-0467	Drive Belt	84	747-1185	Transmission Belt Guard Rod
43	756-0981A	Flat Idler, 2.75 OD	85	710-0599	Self Tapping Screw, 1/4-20 x .5
44	783-0667B	Transmission Torque Bracket	86	756-0639A	Engine Pulley, 3.56"

IMPORTANT: For a proper working machine, use Factory Approved Parts. **V-belts** are designed to engage and disengage safely. A substitute (non OEM) V-belt can be dangerous by not disengaging completely.

NOTE: For **painted parts**, please refer to the list of color codes below. Please add the applicable color code, wherever needed, to the part number to order a replacement part. For instance, if a part numbered 700-xxxx is painted Powder Black, the part number to order would be 700-xxxx-0637.
 Red: 0638
 Oyster Gray: 0662
 Powder Black: 0637

Models Z809H & Z809K

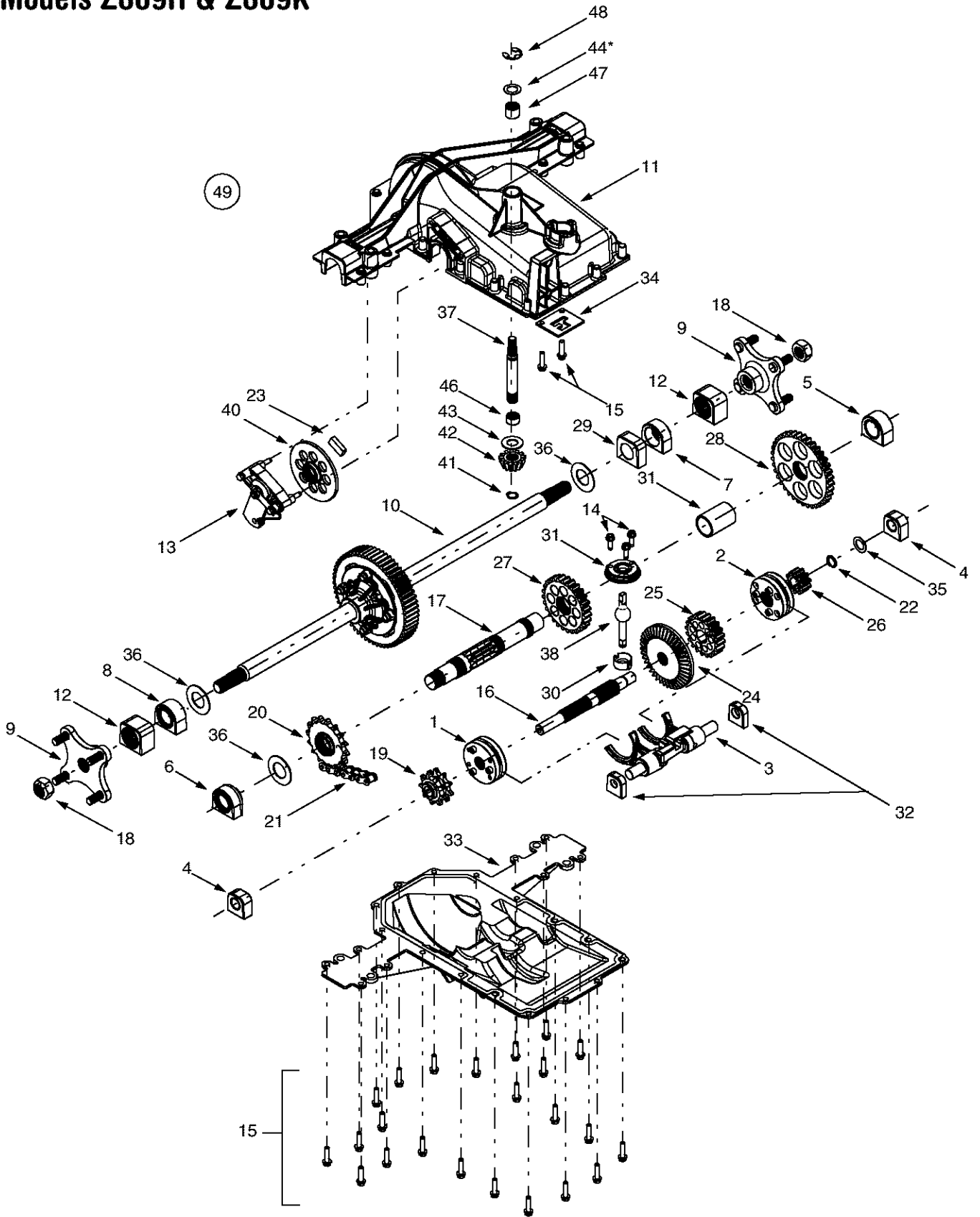

Models Z809H & Z809K

REF. NO.	PART NO.	DESCRIPTION
1	618-0225	Reverse Collar Assembly
2	618-0226	Hi-Lo Collar Assembly
3	618-0227A	Shift Fork Assembly
4	618-0284	Detent Block Assembly
5	618-0285	Output Bearing Block Assembly
6	618-0286	Output Seal Bearing Block Assembly
7	618-0287	Inboard Sealed Axle Block Assembly
8	618-0302	Inboard Sealed Axle Block Assembly
9	618-0365	Wheel Hub Assembly
10	618-0368	Differential Axle Assembly
11	719-0379A	Upper Housing
12	641-0002A	Axle Bearing Block Assembly
13	661-0012	Brake Assembly
14	710-0642	Self-tapping Screw, 1/4-20 x .75
15	710-0788	Self-tapping Screw, 1/4-20 x 1.0
16	711-1051A	Drive Shaft
17	711-1216	Output Shaft
18	712-1329	Nut, 3/4-16
19	713-0446	9-tooth Sprocket
20	713-0447	16-tooth Sprocket
21	713-0448	22-link Chain, .625
22	716-0131	External Snap Ring
23	717-0678	Brake Pad
24	717-1438	41-tooth Bevel Gear
25	717-1439	20-tooth Spur Gear
26	717-1440	10-tooth Spur Gear
27	717-1441	27-tooth Spur Gear
28	717-1442	37-tooth Spur Gear
29	718-0500	Inner Axle Bearing Block
30	718-0504	Shifter Insert
31	718-0505	Shifter Cover
32	718-0537	Shifter Bearing Block
33	719-0385	Lower Housing
34	718-0540	Lockout Plate
35	736-0337	Flat Washer, 5/8 x 1.0
36	736-3046A	Flat Washer, 1.01 x 1.86 x .060
37	711-1235	Input Shaft
38	747-1140	Shift Lever
39	750-1033A	Spacer, 1.13 x 1.38 x 1.968
40	761-0215	Disc Brake
41	716-0114	Retaining Ring, .56
42	717-1463	13-tooth Bevel Gear
43	736-0335	Flat Washer
44	736-0336	Flat Washer, 5/8 x 1.0 x .030*
	736-0337	Flat Washer, 5/8 x 1.0 x .040*
	736-0349	Flat Washer, 5/8 x 1.0 x .020*
46	741-0335	Needle Bearing
47	741-0696	Needle Bearing
48	716-0231	E-ring, .75
49	618-0376	Transmission Assembly Complete

NOTE: Transmission has a grease capacity of 32 oz. Order part number 737-0148.

NOTE: Upon reassembling transmission input shaft for any reason, refill its cavity with approximately 2/3 oz. of grease. Order part number 737-0289.

*Use applicable flat washer (12a, 12b or 12c) in this application allowing proper end-play as instructed in *Troy-Bilt's Service Manual*.

Models Z809H & Z809K

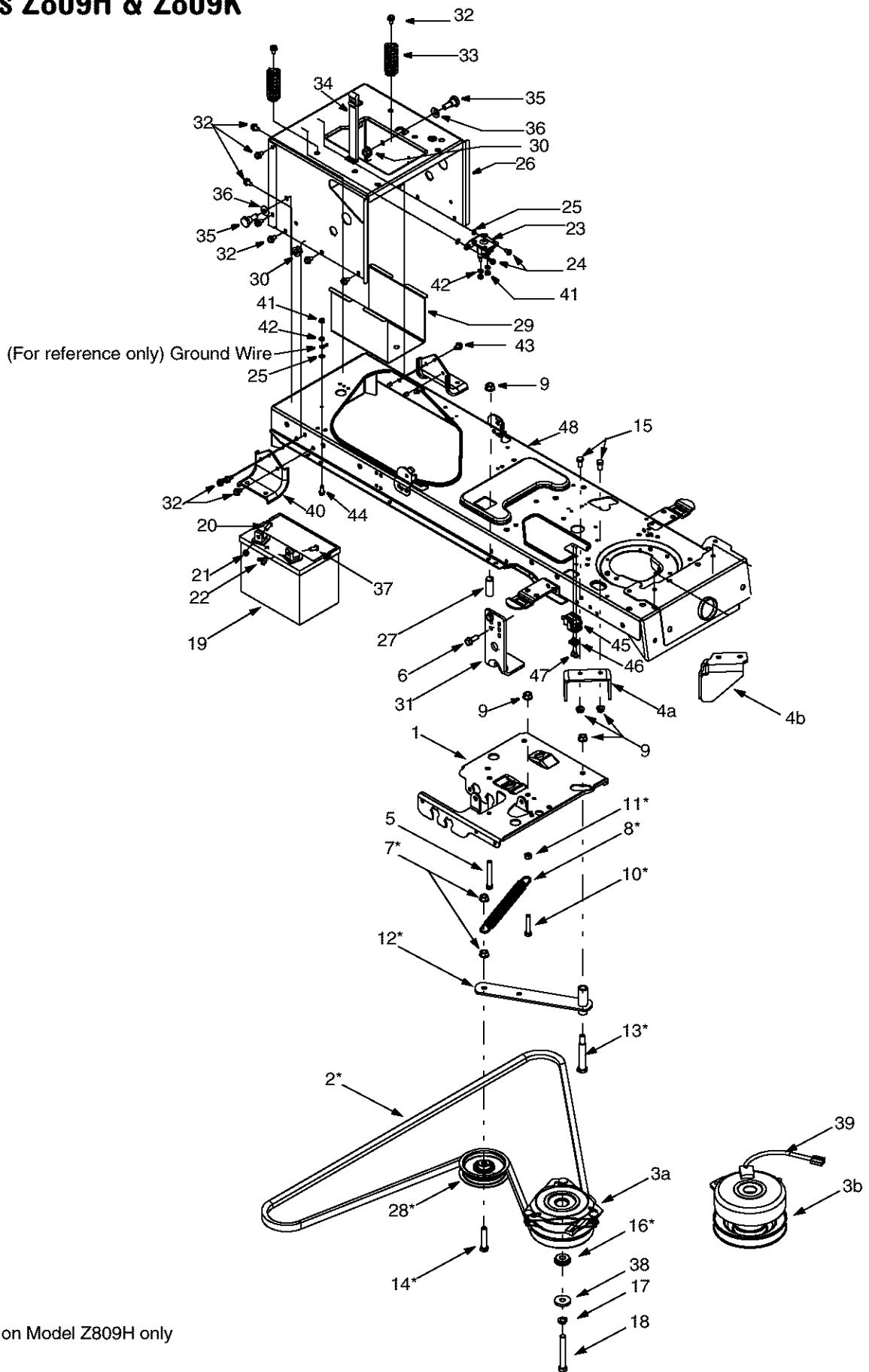

* Found on Model Z809H only

Models Z809H & Z809K

REF. NO.	PART NO.	DESCRIPTION	REF. NO.	PART NO.	DESCRIPTION
1	783-0653E	Steering Support Bracket	24	710-0599	Self Tapping Screw, 1/4-20 x .5
2	754-0476	PTO Belt	25	736-0222	Lock Washer, 1/4
3a	717-1709	Elec. PTO Clutch (Mod. Z809H)	26	783-1033A	Hitch Plate
3b	717-1774	Elec. PTO Clutch (Mod. Z809K) (Incl. # 39)	27	748-0415B	Spacer, 3/8 x 1.54
4a	783-1003	PTO Clutch Anti-rot. Brakt. (Model Z809H)	28	756-0627B	Idler Pulley, 3.5
4b	783-1487	PTO Clutch Anti-rot. Brakt. (Model Z809K)	29	783-0349	Battery Tray
5	710-0859	Hex Cap Screw, 3/8-16 x 2.5	30	712-0459	Flange Lock Nut, 7/16-20
6	710-1238	Hex Head Washer Screw, 5/16-18 x .875	31	783-0891B	Deck Stop
7	712-0431	Flange Lock Nut, 3/8-16	32	710-0604A	Self Tapping Screw, 5/16-18 x .625
8	732-0978	Extension Spring, .62 x 5.62	33	732-3080	Compression Spring, 1.28 x 3.5
9	712-3004A	Flange Lock Nut, 5/16-18	34	723-0444	Battery Strap
10	710-3180	Hex Cap Screw, 5/16-18 x 1.75	35	738-1020	Shoulder Screw, .625 x .5, 7/16-20
11	712-3010	Hex Nut, 5/16-18	36	736-0407	Bell Washer, .45 x 1.0 x .062
12	683-0294	Idler Bracket Assembly	37	738-1132	Shoulder Screw, 1/4-20, .25 x .15
13	738-3056	Shoulder Screw, 1/2 x 2.5	38	736-0322	Flat Washer, .45 x 1.25 x .164
14	710-3144	Hex Cap Screw, 3/8-16 x 2.0	39	629-04047	Harness Assembly, Electric PTO Clutch
15	710-3025	Hex Cap Screw, 5/16-18 x .625	40	783-0693	Axle Bracket
16	738-0785	Shoulder Spacer, 1.38 x .445 x .36	41	712-3006	Hex Nut 1/4-20
17	736-0171	Lock Washer, 7/16	42	736-0329	Lock Washer
18	710-3157	Hex Cap Screw, 7/16-20 x 3.25	43	710-0607	TT Screw 5/16-18 x 0.5
19	725-1706	12-volt Battery, 270 CCA	44	710-0642	TT Screw 1/4-20 x 0.75
20	710-0751	Hex Cap Screw, 1/4-20 x .62	45	725-1657A	Switch
21	712-0271	Hex Sems Nut, 1/4-20	46	17962	Switch Plate
22	712-3087	Wing Nut, 1/4-20	47	710-0224	AB Screw #10-16 x 0.5
23	725-1426	Solenoid, 12-Volt, 100 Amp	48	683-0304C	Lower Frame Assembly

IMPORTANT: For a proper working machine, use Factory Approved Parts. **V-belts** are designed to engage and disengage safely. A substitute (non OEM) V-belt can be dangerous by not disengaging completely.

NOTE: For **painted parts**, please refer to the list of color codes below. Please add the applicable color code, wherever needed, to the part number to order a replacement part. For instance, if a part numbered 700-xxxx is painted Powder Black, the part number to order would be 700-xxxx-0637.
 Red: 0638
 Oyster Gray: 0662
 Powder Black: 0637

Model Z809H

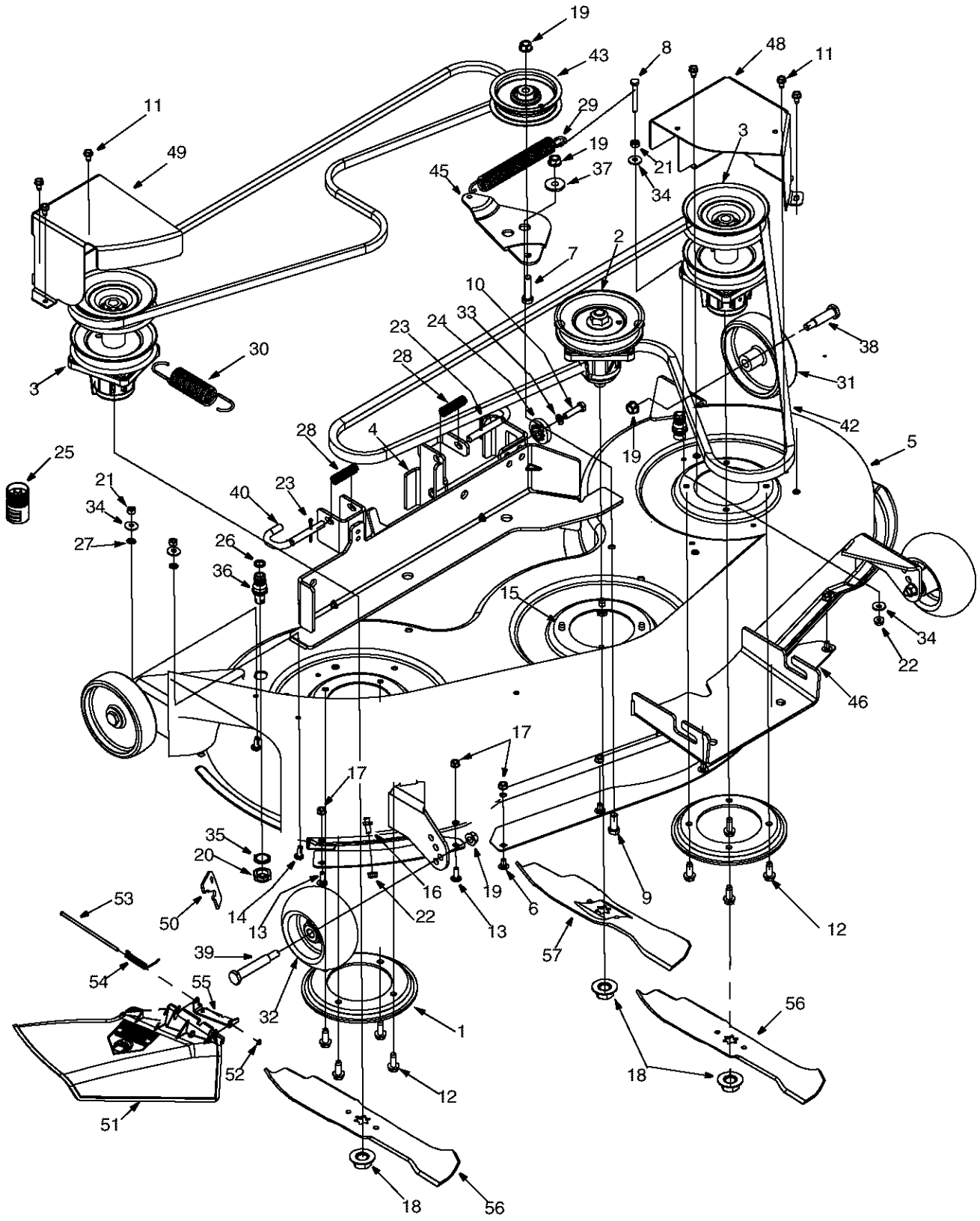

Model Z809H

REF. NO.	PART NO.	DESCRIPTION
1.	17982	Spindle Reinforcement Plate
2.	618-0430A	Spindle Assembly, 5.0 Dia.
	756-1187	Pulley Only
3.	618-0595	Double Pulley Spindle Assembly
	756-0603	Double Pulley Only
4.	683-0254	Deck Adjustment Bracket Assembly
5.	683-04053	46-inch Deck Assembly
6.	710-0167	Carriage Screw, 1/4-20 x .50
7.	710-0344	Hex Cap Screw, 3/8-16 x 1.5
8.	710-0501	Hex Cap Screw, 1/4-20 x 2.0
9.	710-0514	Hex Cap Screw, 3/8-16 x 1.0
10.	710-0528	Hex Cap Screw, 5/8-18 x 1.25
11.	710-0599	Self-tapping Screw, 1/4-20 x .5
12.	710-0650	Self-tapping Screw, 15/16-18 x .875
13.	710-0703	Hex Screw, 1/4-20 x .75
14.	710-0751	Hex Cap Screw, 1/4-20 x .62
15.	710-1260A	Self-tapping Screw, 5/16-18 x .75
16.	711-04069	Grasscatcher Pin
17.	712-0271	Hex Sems Nut, 1/4-20
18.	712-0417A	Hex Flange Nut, 5/8-18
19.	712-0431	Flange Lock Nut, 3/8-16
20.	712-0641	Hex Nut M16
21.	712-3006	Hex Nut, 1/4-20
22.	712-3027	Hex Flange Lock Nut, 1/4-20
23.	714-0470	Cotter Pin, 1/8 x 1.25
24.	717-1553B	Deck Adjustment Gear
25.	721-04041	Nozzle Adapter
27.	726-0233	Push Nut. .25 x .5
28.	732-0306	Compression Spring, .406 x .531 x 1.75
29.	732-0594A	Extension Spring, .91 x 7.3
30.	732-0934	Extension Spring
31.	734-0973	Deck Wheel
32.	734-3058B	Deck Wheel
33.	736-0119	Lock Washer, 5/16
34.	736-0270	Bell Washer, .265 x .75 x .062
35.	736-0760	Lock Washer
36.	737-04003	Nozzle: Deck Wash-Out System
37.	738-0347	Shoulder Spacer, .625 x 1.16
38.	738-0373	Shoulder Screw
39.	738-3056	Shoulder Screw
40.	747-1116	Deck Release Pin
41.	754-0349	Deck Belt, Poly
42.	754-0476	V-Belt
43.	756-0627B	Idler Pulley, 3.5
45.	783-0139A	Idler Bracket
46.	783-0141	Center Deck Skirt
47.	783-0142	RH Deck Skirt
48.	783-1347A	LH Belt Cover
49.	783-1450	RH Belt Cover
50.	783-1025	Chute Stop
51.	731-1032B	Chute Deflector: Side Discharge
52.	726-0106	Speed Nut
53.	711-0792	Hinge Pin
54.	703-1693A	Mounting Bracket
55.	732-0602	Torsion Spring
56.	742-0611	Blade: 16.28" Star
57.	742-0612	Blade: 14.88" Star

IMPORTANT: For a proper working machine, use Factory Approved Parts. **V-belts** are designed to engage and disengage safely. A substitute (non OEM) V-belt can be dangerous by not disengaging completely.

Model Z809K

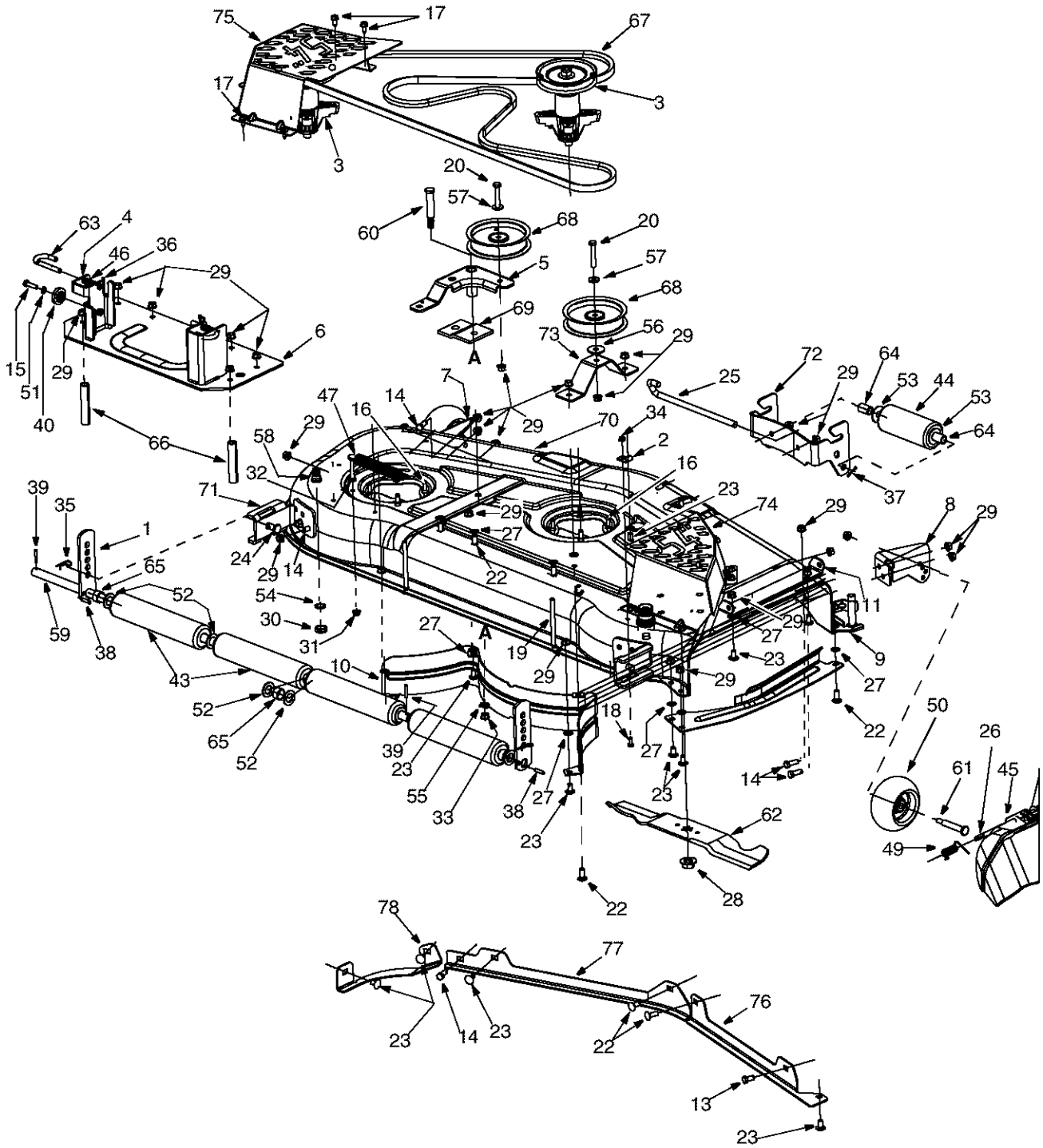

Model Z809K

REF. NO.	PART NO.	DESCRIPTION	REF. NO.	PART NO.	DESCRIPTION
1.	12650	Bracket, Adjustment, Height	40.	717-1553B	Adjustment, Deck, Gear
2.	16606	Bracket, Hook, Retainer	41.	721-04041	Water Nozzle Adaptor
3.	618-0671	Spindle Assembly, Pulley, 5.39 Dia x .5625	43.	731-0335	Roller, Deck
4.	683-0254	Bracket Assembly, Deck, Hanger LH	44.	731-3005	Front Roller
5.	683-0459	Idlr Assembly, 54"	45.	731-3131A	Deflector, Chute
6.	683-0608	Bracket Assembly, Lift, 54"	46.	732-0306	Spring, Compression, .406 x .531 x 1.75
7.	683-0609	Bracket Assembly, LH-Front	47.	732-0459	Spring, Extension, .94 Dia x 6.74
8.	683-0610	Bracket Assembly, RH-Front	48.	732-0934	Spring, Extension, 1.15 Dia x 5.99
9.	683-0617	Stop Assembly, Chute	49.	732-3070	Torsion Spring .44 I.d. x 2.10
10.	703-2093	Baffle, RR, Inner	50.	734-3058B	Deck Wheel, 5" Dia.
11.	703-2392	Bracket	51.	736-0119	Lock Washer
12.	703-3511	Guard, Finger	52.	736-0134	Flat Washer, .812 ID x 1.38 OD x .1
13.	710-0216	Hex Screw 3/8-16 x 0.75	53.	736-0208	Flat Washer, .51 ID x 1.5 OD x .07
14.	710-0514	Hex Screw 3/8-16 x 1.0	54.	736-0760	Lock Washer
15.	710-0528	Hex Screw, 5/16-18 x 1.25	55.	736-0921	Washer, Lock, 1/2 , Regular Duty
16.	710-0602	Screw, Self-tapping, 5/16-18 x 1.000	56.	736-3039	Flat Washer .406 ID X 1.5 x 11ga
17.	710-0726	Screw, AB, 5/16-12 x 0.75	57.	736-3072	Washer, Flat .38 ID x.93 OD x.110
18.	710-0751	Hex Screw, 1/4-20 x .620	58.	737-04003	Water Nozzle: Deck Wash-Out System
19.	710-1644	Screw, Carriage, 3/8-16 x 5.00	59.	738-0295	Shoulder Screw, .750 x .47.12
20.	710-3011	Hex Screw, 3/8-16 x 2.25	60.	738-1229A	Shoulder Screw
21.	710-3073	Hex Screw, 5/16-18 x 2.25	61.	738-3056	Shoulder Screw, 1/2 Dia x 2.50 .
22.	710-3168	Bolt, Carriage, 3/8-16 x 1.0	62.	742-0677	Blade, 18.50"
23.	710-3178	Short Neck Carriage Bolt 3/8-16 x .75	63.	747-1116	Deck Release Handle Rod, .375 Dia
24.	711-0332	Pin, Clevis, .50 Dia x .78	64.	750-0151	Spacer .550 ID x .755 OD x 1.1
25.	711-1737	Pin, Roller, .5" Dia x 10.06 .	65.	750-0212	Spacer, .82 ID x 1.00 OD x .53
26.	711-1762	Pin, Hinge, Dia .375 x 14.06	66.	750-3213	Spacer, .405 x .75 x 3.875
27.	712-0229	Push Nut Retainer	67.	754-0642	Belt, V-Type, B Section
28.	712-0417A	Nut, Hex Flange, 5/8-18	68.	756-3105	Pulley, Idler, 5.0 Dia.
29.	712-0431	Nut, Flange Lock, 3/8-16	69.	783-04013A	Bracket, Stabilizing
30.	712-0641	Hex Nut M16	70.	783-04232	Deck: SD w/Water Nozzle Ftg.
31.	712-3004A	Nut, Flange Lock, 5/16-18, Gr5	71.	783-1453	Bracket, Mounting, 54" Roller
32.	712-3010	Nut, Hex, 5/16-18, Gr5	72.	783-1454	Bracket, Roller, Front
33.	712-3022	Nut, Hex Lock, 1/2-13	73.	783-1455	Bracket, Idler
34.	712-3027	Nut, 1/4-20, Hexflg, Lock	74.	783-1470	Cover, Spindle RH
35.	714-0145	Pin, Click, .092 x 1.64	75.	783-1471	Cover, Spindle LH
36.	714-0470	Pin, Cotter, 1/8 x 1.25	76.	783-1482	RH Skirt
37.	714-3004	Pin, Cotter, 3/32 x 1.25	77.	783-1483	LH Skirt
38.	715-0108	Pin, Sprng, 1/4 Dia x 1.00	78.	783-1484	LH Extension Skirt
39.	715-0246	Pin, Spring, 3/16 x 1.25			

IMPORTANT: For a proper working machine, use Factory Approved Parts. **V-belts** are designed to engage and disengage safely. A substitute (non OEM) V-belt can be dangerous by not disengaging completely.

NOTE: For **painted parts**, please refer to the list of color codes below. Please add the applicable color code, wherever needed, to the part number to order a replacement part. For instance, if a part numbered 700-xxxx is painted Powder Black, the part number to order would be 700-xxxx-0637.

Red: 0638
Oyster Gray: 0662
Powder Black: 0637

MANUFACTURER'S LIMITED WARRANTY FOR:



The limited warranty set forth below is given by Troy-Bilt LLC with respect to new merchandise purchased and used in the United States, its possessions and territories.

Troy-Bilt LLC warrants this product against defects for a period of two (2) years commencing on the date of original purchase and will, at its option, repair or replace, free of charge, any part found to be defective in materials or workmanship. This limited warranty shall only apply if this product has been operated and maintained in accordance with the Operator's Manual furnished with the product, and has not been subject to misuse, abuse, commercial use, neglect, accident, improper maintenance, alteration, vandalism, theft, fire, water, or damage because of other peril or natural disaster. Damage resulting from the installation or use of any accessory or attachment not approved by Troy-Bilt LLC for use with the product(s) covered by this manual will void your warranty as to any resulting damage.

Normal wear parts or components thereof are subject to separate terms as follows: All normal wear parts or component failures will be covered on the product for a period of 90 days regardless of cause. After 90 days, but within the two year period, normal wear part failures will be covered ONLY IF caused by defects in materials or workmanship of OTHER component parts. Normal wear parts and components include, but are not limited to: batteries, belts, blades, blade adapters, grass bags, rider deck wheels, seats, snow thrower skid shoes, shave plates, auger spiral rubber, and tires.

HOW TO OBTAIN SERVICE: Warranty service is available, WITH PROOF OF PURCHASE, through your local authorized service dealer. To locate the dealer in your area, check your Yellow Pages, or contact Troy-Bilt LLC at P.O. Box 361131, Cleveland, Ohio 44136-0019, or call 1-866-840-6483 or 1-330-558-7220, or log on to our Web site at www.troybilt.com.

This limited warranty does not provide coverage in the following cases:

- a. The engine or component parts thereof. These items carry a separate manufacturer's warranty. Refer to applicable manufacturer's warranty for terms and conditions.
- b. Log splitter pumps, valves, and cylinders have a separate one year warranty.
- c. Routine maintenance items such as lubricants, filters, blade sharpening, tune-ups, brake adjustments, clutch adjustments, deck adjustments, and normal deterioration of the exterior finish due to use or exposure.

- d. Troy-Bilt LLC does not extend any warranty for products sold or exported outside of the United States, its possessions and territories, except those sold through Troy-Bilt LLC's authorized channels of export distribution.
- e. Parts that are not genuine Troy-Bilt parts are not covered by this warranty.
- f. Service completed by someone other than an authorized service dealer is not covered by this warranty.
- g. Transportation charges and service calls are not covered.

No implied warranty, including any implied warranty of merchantability of fitness for a particular purpose, applies after the applicable period of express written warranty above as to the parts as identified. No other express warranty, whether written or oral, except as mentioned above, given by any person or entity, including a dealer or retailer, with respect to any product, shall bind Troy-Bilt LLC. During the period of the warranty, the exclusive remedy is repair or replacement of the product as set forth above.

The provisions as set forth in this warranty provide the sole and exclusive remedy arising from the sale. Troy-Bilt LLC shall not be liable for incidental or consequential loss or damage including, without limitation, expenses incurred for substitute or replacement lawn care services or for rental expenses to temporarily replace a warranted product.

Some states do not allow the exclusion or limitation of incidental or consequential damages, or limitations on how long an implied warranty lasts, so the above exclusions or limitations may not apply to you.

In no event shall recovery of any kind be greater than the amount of the purchase price of the product sold.

Alteration of safety features of the product shall void this warranty. You assume the risk and liability for loss, damage, or injury to you and your property and/or to others and their property arising out of the misuse or inability to use the product.

This limited warranty shall not extend to anyone other than the original purchaser or to the person for whom it was purchased as a gift.

HOW STATE LAW RELATES TO THIS WARRANTY:

This limited warranty gives you specific legal rights, and you may also have other rights which vary from state to state.