

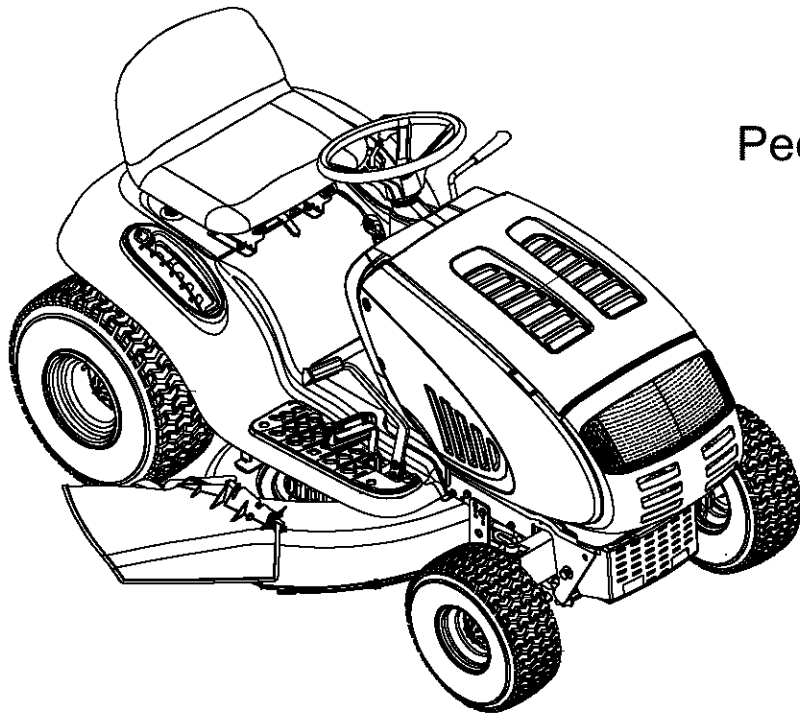

Operator's Manual



Pedal Drive Lawn Tractor
Models LTX-1842
LTX-2146

IMPORTANT: Read safety rules and instructions carefully before operating equipment.

Warning: This unit is equipped with an internal combustion engine and should not be used on or near any unimproved forest-covered, brush-covered or grass-covered land unless the engine's exhaust system is equipped with a spark arrester meeting applicable local or state laws (if any). If a spark arrester is used, it should be maintained in effective working order by the operator. In the State of California the above is required by law (Section 4442 of the California Public Resources Code). Other states may have similar laws. Federal laws apply on federal lands. A spark arrester for the muffler is available through your nearest engine authorized service dealer or contact the service department, P.O. Box 361131 Cleveland, Ohio 44136-0019.

TROY-BILT LLC. P.O. BOX 361131, CLEVELAND, OHIO 44136-0019

PRINTED IN U.S.A.

FORM NO. 770-10490B
(2/2003)

TABLE OF CONTENTS

Content	Page
Important Safe Operation Practices.....	3
Slope Gauge.....	7
Tractor Set-up.....	8
Know Your Lawn Tractor	10
Operating Your Lawn Tractor	13
Making Adjustments	16
Maintaining Your Lawn Tractor.....	18
Service	20
Off-Season Storage.....	25
Attachments & Accessories.....	25
Troubleshooting.....	26
Models LTX-1842 & LTX-2146 Parts List.....	27

FINDING MODEL NUMBER

This Operator's Manual is an important part of your new lawn tractor. It will help you assemble, prepare and maintain the unit for best performance. Please read and understand what it says.



Before you start assembling your new equipment, please locate the model plate on the equipment and copy the information from it in the space provided below. The information on the model plate is very important if you need help from our Customer Support Department or an authorized dealer.

- You can locate the model number by looking beneath the seat. A sample model plate is explained below. For future reference, please copy model number and serial number of the equipment in the space below.

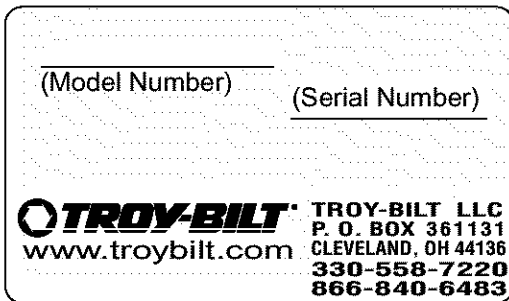

Copy the model number here: _____

Copy the serial number here: _____

ENGINE INFORMATION

The engine manufacturer is responsible for all engine-related issues with regards to performance, power-rating, specifications, warranty and service. Please refer to the engine manufacturer's Owner's/Operator's Manual packed separately with your unit for more information.

CALLING CUSTOMER SUPPORT

If you have difficulty assembling this product or have any questions regarding the controls, operation or maintenance of this unit, please call the Customer Support Department.



Call **1-866-840-6483** or **1-330-558-7220** to reach a Customer Support representative. Please have your unit's model number and serial number ready when you call. See previous section to locate this information. You will be asked to enter the serial number in order to process your call.

For more details about your unit, visit our website at www.troybilt.com

SECTION 1: IMPORTANT SAFE OPERATION PRACTICES



WARNING: This symbol points out important safety instructions which, if not followed, could endanger the personal safety and/or property of yourself and others. Read and follow all instructions in this manual before attempting to operate this machine. Failure to comply with these instructions may result in personal injury. When you see this symbol—heed its warning.



WARNING: The Battery and Engine Exhaust contains chemicals known to the State of California to cause cancer, birth defects or other reproductive harm. The battery and posts contain lead; wash hands after handling.



WARNING: This machine was built to be operated according to the rules for safe operation in this manual. As with any type of power equipment, carelessness or error on the part of the operator can result in serious injury. This machine is capable of amputating hands and feet and throwing objects. Failure to observe the following safety instructions could result in serious injury or death.

General Operation

1. Read, understand, and follow all instructions on the machine and in the manual(s) before attempting to assemble and operate. Keep this manual in a safe place for future and regular reference and for ordering replacement parts.
2. Be familiar with all controls and their proper operation. Know how to stop the machine and disengage them quickly.
3. Never allow children under 14 years old to operate this machine. Children 14 years old and over should read and understand the operation instructions and safety rules in this manual and should be trained and supervised by a parent.
4. Never allow adults to operate this machine without proper instruction.
5. To help avoid blade contact or a thrown object injury, keep bystanders, helpers, children and pets at least 75 feet from the machine while it is in operation. Stop machine if anyone enters the area.
6. Thoroughly inspect the area where the equipment is to be used. Remove all stones, sticks, wire, bones, toys, and other foreign objects which could be picked up and thrown by the blade(s). Thrown objects can cause serious personal injury.
7. Plan your mowing pattern to avoid discharge of material toward roads, sidewalks, bystanders and the like. Also, avoid discharging material against a wall or obstruction which may cause discharged material to ricochet back toward the operator.
8. Always wear safety glasses or safety goggles during operation and while performing an adjustment or repair to protect your eyes. Thrown objects which ricochet can cause serious injury to the eyes.
9. Wear sturdy, rough-soled work shoes and close-fitting slacks and shirts. Loose fitting clothes and jewelry can be caught in movable parts. Never operate this machine in bare feet or sandals.
10. Be aware of the mower and attachment discharge direction and do not point it at anyone. Do not operate the mower without the discharge cover or entire grass catcher in its proper place.
11. Do not put hands or feet near rotating parts or under the cutting deck. Contact with the blade(s) can amputate hands and feet.
12. A missing or damaged discharge cover can cause blade contact or thrown object injuries.
13. Stop the blade(s) when crossing gravel drives, walks, or roads and while not cutting grass.
14. Watch for traffic when operating near or crossing roadways. This machine is not intended for use on any public roadway.
15. Do not operate the machine while under the influence of alcohol or drugs.
16. Mow only in daylight or good artificial light.
17. Never carry passengers.
18. Disengage blade(s) before shifting into reverse. Back up slowly. Always look down and behind before and while backing to avoid a back-over accident.
19. Slow down before turning. Operate the machine smoothly. Avoid erratic operation and excessive speed.
20. Disengage blade(s), set parking brake, stop engine and wait until the blade(s) come to a complete stop before removing grass catcher, emptying grass, unclogging chute, removing any grass or debris, or making any adjustments.
21. Never leave a running machine unattended. Always turn off blade(s), place transmission in neutral, set parking brake, stop engine and remove key before dismounting.
22. Use extra care when loading or unloading the machine into a trailer or truck. This unit should not be driven up or down ramp(s), because the unit could tip over, causing serious personal injury. The unit must be pushed manually on ramp(s) to load or unload properly.

23. Muffler and engine become hot and can cause a burn. Do not touch.
24. Check overhead clearances carefully before driving under low tree branches, wires, door openings etc., where the operator may be struck or pulled from the unit, which could result in serious injury.
25. Disengage all attachment clutches, depress the brake pedal completely and shift into neutral before attempting to start engine.
26. Your machine is designed to cut normal residential grass of a height no more than 10". Do not attempt to mow through unusually tall, dry grass (e.g., pasture) or piles of dry leaves. Dry grass or leaves may contact the engine exhaust and/or build up on the mower deck presenting a potential fire hazard.
27. Use only accessories and attachments approved for this machine by the machine manufacturer. Read, understand and follow all instructions provided with the accessory or attachment.
28. Data indicates that operators, age 60 years and above, are involved in a large percentage of tractor-related injuries. These operators should evaluate their ability to operate the tractor safely enough to protect themselves and others from serious injury.
29. If situations occur which are not covered in this manual, use care and good judgment. Contact your Yard-Man dealer for assistance.

Slope Operation

Slopes are a major factor related to loss of control and tip-over accidents which can result in severe injury or death. All slopes require extra caution. If you cannot back up the slope or if you feel uneasy, do not mow it.

For your safety, use the slope gauge included as part of this manual to measure slopes before operating this unit on a sloped or hilly area. If the slope is greater than 15 degrees as shown on the slope gauge, do not operate this unit on that area.

Do:

1. Mow up and down slopes, not across. Exercise extreme caution when changing direction on slopes.
2. Watch for holes, ruts, bumps, rocks, or other hidden objects. Uneven terrain could overturn the machine. Tall grass can hide obstacles.
3. Use slow speed. Choose a low enough speed setting so that you will not have to stop or shift while on the slope. Tires may lose traction on slopes even though the brakes are functioning properly. Always keep machine in gear when going down slopes to take advantage of engine braking action.
4. Follow the manufacturer's recommendations for wheel weights or counterweights to improve stability of the machine. Use extra care with grass catchers or other attachments. These can change stability of the machine.

5. Keep all movement on the slopes slow and gradual. Do not make sudden changes in speed or direction. Rapid engagement or braking could cause the front of the machine to lift and rapidly flip over backwards which could cause serious injury.
6. Avoid starting or stopping on a slope. If tires lose traction, disengage the blade(s) and proceed slowly straight down the slope.

Do Not:

1. Do not turn on slopes unless necessary; then, turn slowly and gradually downhill, if possible.
2. Do not mow near drop-offs, ditches or embankments. The mower could suddenly turn over if a wheel is over the edge of a cliff, ditch, or if an edge caves in.
3. Do not try to stabilize the machine by putting your foot on the ground.
4. Do not use a grass catcher on steep slopes.
5. Do not mow on wet grass. Reduced traction could cause sliding.
6. Do not shift to neutral and coast downhill. Over-speeding may cause the operator to lose control of the machine resulting in serious injury or death.
7. Do not tow heavy pull behind attachments (e.g. loaded dump cart, lawn roller, etc.) on slopes greater than 5 degrees. When going down hill, the extra weight tends to push the tractor and may cause you to lose control. (e.g. tractor may speed up, braking and steering ability are reduced, attachment may jack-knife and cause tractor to overturn).

Children

1. Tragic accidents can occur if the operator is not alert to the presence of children. Children are often attracted to the machine and the mowing activity. They do not understand the dangers. Never assume that children will remain where you last saw them.
 - a. Keep children out of the mowing area and in watchful care of a responsible adult other than the operator.
 - b. Be alert and turn machine off if a child enters the area.
 - c. Before and while backing, look behind and down for small children.
 - d. Never carry children, even with the blade(s) shut off. They may fall off and be seriously injured or interfere with safe machine operation.
 - e. Use extreme care when approaching blind corners, doorways, shrubs, trees or other objects that may block your vision of a child who may run into the machine.
 - f. Disengage the cutting blade(s) before shifting in reverse. The "No-Cut-In Reverse"

- feature emphasises not to cut in reverse and to avoid back-over accidents; do not defeat it.
 - g. Keep children away from hot or running engines. They can suffer burns from a hot muffler.
 - h. Remove key when machine is unattended to prevent unauthorized operation.
9. Never allow children under 14 years old to operate the machine. Children 14 years old and over should read and understand the operation instructions and safety rules in this manual and should be trained and supervised by a parent.

Towing

1. Tow only with a machine that has a hitch designed for towing. Do not attach towed equipment except at the hitch point.
2. Follow the manufacturers recommendation for weight limits for towed equipment and towing on slopes.
3. Never allow children or others in or on towed equipment.
4. On slopes, the weight of the towed equipment may cause loss of traction and loss of control.
5. Travel slowly and allow extra distance to stop.
6. Do not shift to neutral and coast downhill.

Service

Safe Handling Of Gasoline

1. To avoid personal injury or property damage use extreme care in handling gasoline. Gasoline is extremely flammable and the vapors are explosive. Serious personal injury can occur when gasoline is spilled on yourself or your clothes which can ignite. Wash your skin and change clothes immediately.
 - a. Use only an approved gasoline container.
 - b. Never fill containers inside a vehicle or on a truck or trailer bed with a plastic liner. Always place containers on the ground away from your vehicle before filling.
 - c. When practical, remove gas-powered equipment from the truck or trailer and refuel it on the ground. If this is not possible, then refuel such equipment on a trailer with a portable container, rather than from a gasoline dispenser nozzle.
 - d. Keep the nozzle in contact with the rim of the fuel tank or container opening at all times until fueling is complete. Do not use a nozzle lock-open device.
 - e. Extinguish all cigarettes, cigars, pipes and other sources of ignition.
 - f. Never fuel machine indoors.
 - g. Never remove gas cap or add fuel while the engine is hot or running. Allow engine to cool at least two minutes before refueling.

- h. Never over fill fuel tank. Fill tank to no more than ½ inch below bottom of filler neck to allow space for fuel expansion.
- i. Replace gasoline cap and tighten securely.
- j. If gasoline is spilled, wipe it off the engine and equipment. Move unit to another area. Wait 5 minutes before starting the engine.
- k. To reduce fire hazards, keep machine free of grass, leaves, or other debris build-up. Clean up oil or fuel spillage and remove any fuel soaked debris.
- l. Never store the machine or fuel container inside where there is an open flame, spark or pilot light as on a water heater, space heater, furnace, clothes dryer or other gas appliances.
- m. Allow a machine to cool at least 5 minutes before storing.

General Service

1. Never run an engine indoors or in a poorly ventilated area. Engine exhaust contains carbon monoxide, an odorless, and deadly gas.
2. Before cleaning, repairing, or inspecting, make certain the blade(s) and all moving parts have stopped. Disconnect the spark plug wire and ground against the engine to prevent unintended starting.
3. Periodically check to make sure the blades come to complete stop within approximately (5) five seconds after operating the blade disengagement control. If the blades do not stop within the this time frame, your unit should be serviced professionally by an authorized *White Outdoor Products* dealer.
4. Check brake operation frequently as it is subjected to wear during normal operation. Adjust and service as required.
5. Check the blade(s) and engine mounting bolts at frequent intervals for proper tightness. Also, visually inspect blade(s) for damage (e.g., excessive wear, bent, cracked). Replace the blade(s) with the original equipment manufacturer's (O.E.M.) blade(s) only, listed in this manual. "Use of parts which do not meet the original equipment specifications may lead to improper performance and compromise safety!"
6. Mower blades are sharp. Wrap the blade or wear gloves, and use extra caution when servicing them.
7. Keep all nuts, bolts, and screws tight to be sure the equipment is in safe working condition.
8. Never tamper with the safety interlock system or other safety devices. Check their proper operation regularly.
9. After striking a foreign object, stop the engine, disconnect the spark plug wire(s) and ground against the engine. Thoroughly inspect the machine for any damage. Repair the damage before starting and operating.

10. Never attempt to make adjustments or repairs to the machine while the engine is running.
11. Grass catcher components and the discharge cover are subject to wear and damage which could expose moving parts or allow objects to be thrown. For safety protection, frequently check components and replace immediately with original equipment manufacturer's (O.E.M.) parts only, listed in this manual. "Use of parts which do not meet the original equipment specifications may lead to improper performance and compromise safety!"
12. Do not change the engine governor settings or over-speed the engine. The governor controls the

- maximum safe operating speed of the engine.
13. Maintain or replace safety and instruction labels, as necessary.
14. Observe proper disposal laws and regulations for gas, oil, etc. to protect the environment.

Your Responsibility

Restrict the use of this power machine to persons who read, understand and follow the warnings and instructions in this manual and on the machine.

777S30145



777S30503



777S30018

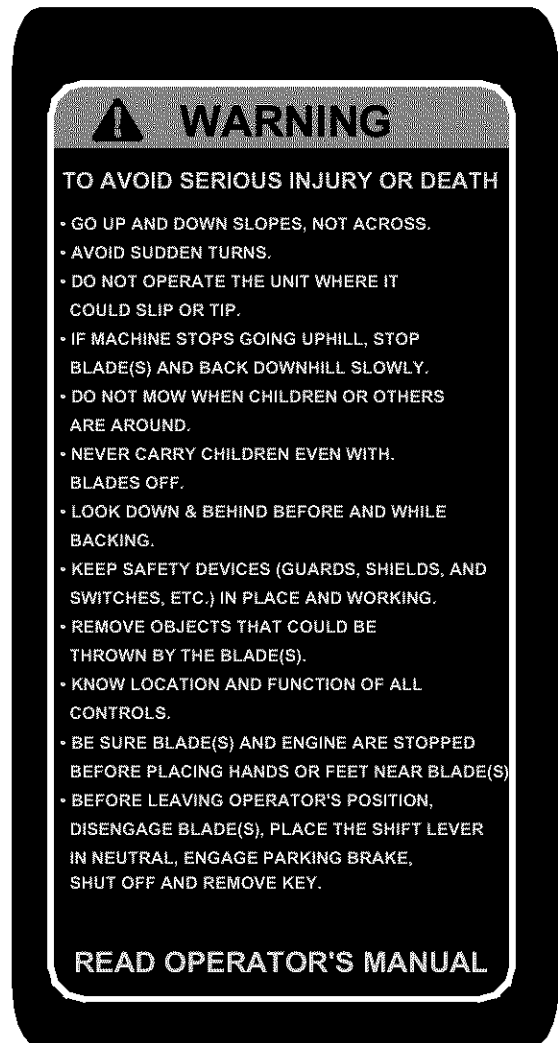

SECTION 2: SLOPE GAUGE

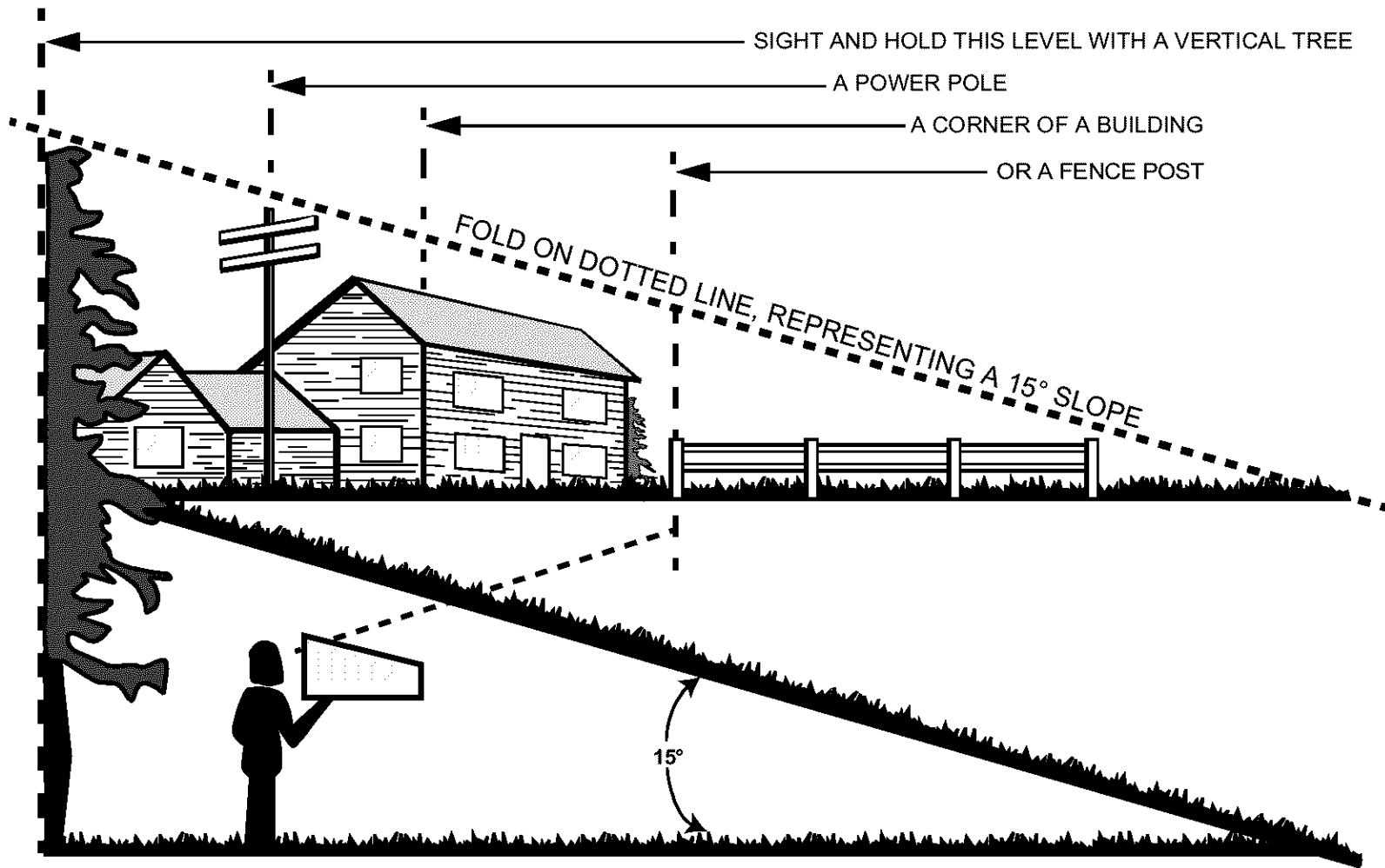

WARNING

Do not mow on inclines with a slope in excess of 15 degrees (a rise of approximately 2-1/2 feet every 10 feet). A riding mower could overturn and cause serious injury. If operating a walk-behind mower on such a slope, it is extremely difficult to maintain your footing and you could slip, resulting in serious injury. Operate RIDING mowers up and down slopes, never across the face of slopes.

SECTION 3: TRACTOR SET-UP

IMPORTANT: Your tractor is shipped with motor oil in the engine. However, you **MUST** check the oil level before starting the engine and operating. Refer to the separate *Briggs & Stratton Operator/Owner Manual* packed with your tractor. Read instructions carefully.

NOTE: Any reference in this manual to the **RIGHT** or **LEFT** side of the tractor is observed from operator's position.

Attaching the Battery Cables

NOTE: The positive battery terminal is marked Pos. (+). The negative battery terminal is marked Neg. (-).

- The positive cable (heavy red wire) is secured to the positive battery terminal (+) with a carriage screw and hex nut at the factory. Make certain that the rubber boot covers the terminal to help protect it from corrosion.
- Remove the shoulder bolt and wing nut from the negative cable.
- Remove the black plastic cover, if present, from the negative battery terminal and attach the negative cable (heavy black wire) to the negative battery terminal (-) with the bolt and the wing nut.
- Make certain the hold-down strap is in position over the battery, securing it in place. See Figure 1.

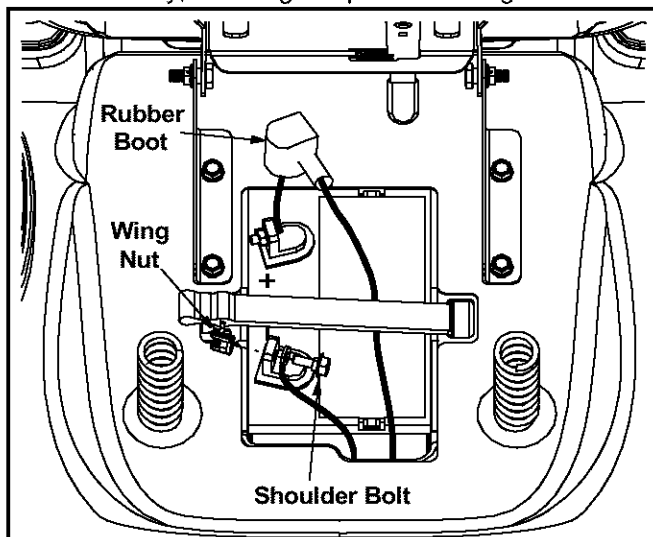

Figure 1

NOTE: If the battery is put into service after the date shown on top of battery, charge the battery as instructed on page 20 of this manual prior to operating the tractor.

Shipping Brace Removal



WARNING: Make sure the riding mower's engine is off, remove the ignition key, and set the parking brake before removing the shipping brace.

- Locate the shipping brace and warning tag found on the right side of the mower, between the discharge chute and the cutting deck. See Figure 2.

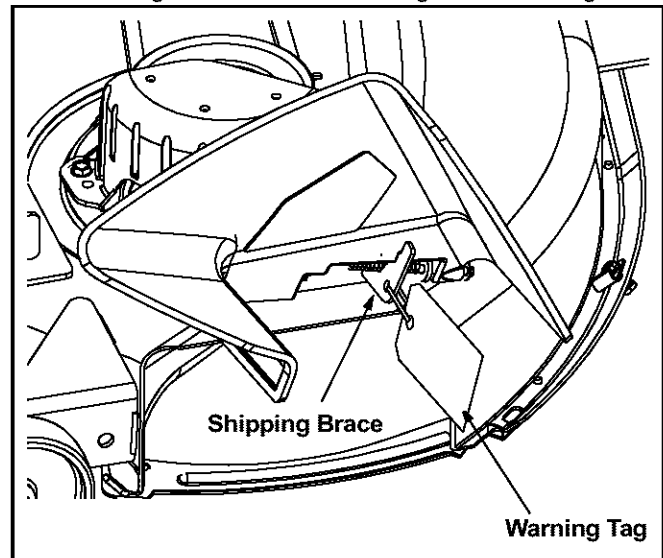

Figure 2

- While holding the discharge chute with your left hand, remove the shipping brace with your right hand by grasping it between your thumb and index finger and rotating it clockwise.



WARNING: The shipping brace, used for packaging purposes only, must be removed and discarded before operating your riding mower.



WARNING: The mowing deck is capable of throwing objects. Failure to operate the riding mower without the discharge cover in the proper operating position could result in serious personal injury and/or property damage.

Tire Pressure



WARNING: Maximum tire pressure under any circumstances is 30 psi. Equal tire pressure should be maintained at all times.

The tires on your unit may be over-inflated for shipping purposes. Reduce the tire pressure before operating the tractor. Recommended operating tire pressure is approximately 10 p.s.i. for the rear tires & 14 p.s.i. for the front tires. Check sidewall of tire for maximum p.s.i.

Gas and Oil Fill-up

The gasoline tank is located under the hood and has a capacity of either two or three gallons. Do not overfill.



WARNING: Use extreme care when handling gasoline. Gasoline is extremely flammable and the vapors are explosive. Never fuel machine indoors or while the engine is hot or running. Extinguish cigarettes, cigars, pipes, and other sources of ignition.

Service the engine with gasoline and oil as instructed in the separate *Briggs & Stratton Operator/Owner Manual* packed with your tractor. Read instructions carefully.

IMPORTANT: Your tractor is shipped with motor oil in the engine. However, you **MUST** check the oil level before operating. Be careful not to overfill.

Identifying the Mulch Plug

On tractor models LTX-1842, a mulch plug can be found within the cutting deck's discharge opening.

NOTE: Refer to **Mulching** on page 15 for more detailed information.

If you'd prefer to operate the cutting deck without

mulching, simply remove the mulch plug by unthreading the plastic wing nut which fastens it to the cutting deck. This will allow the clippings to discharge out of the discharge opening during operation. See Figure 3.

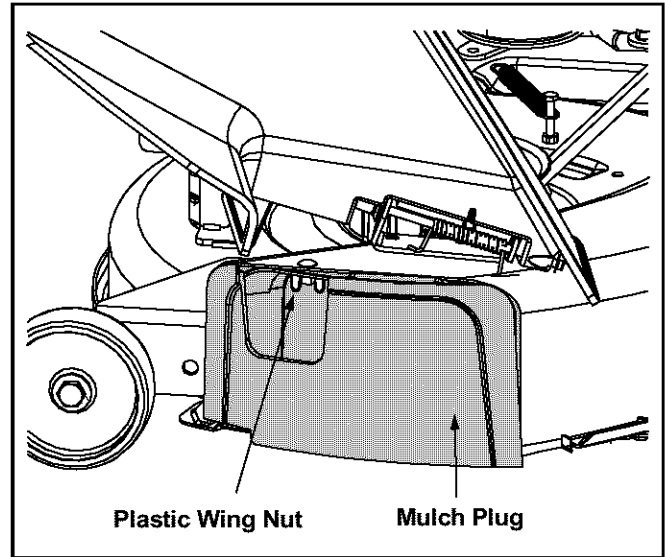

Figure 3

NOTE: On tractor models LTX-2146, the mulch kit is packed separately within the tractor's crate.

SECTION 4: KNOW YOUR LAWN TRACTOR

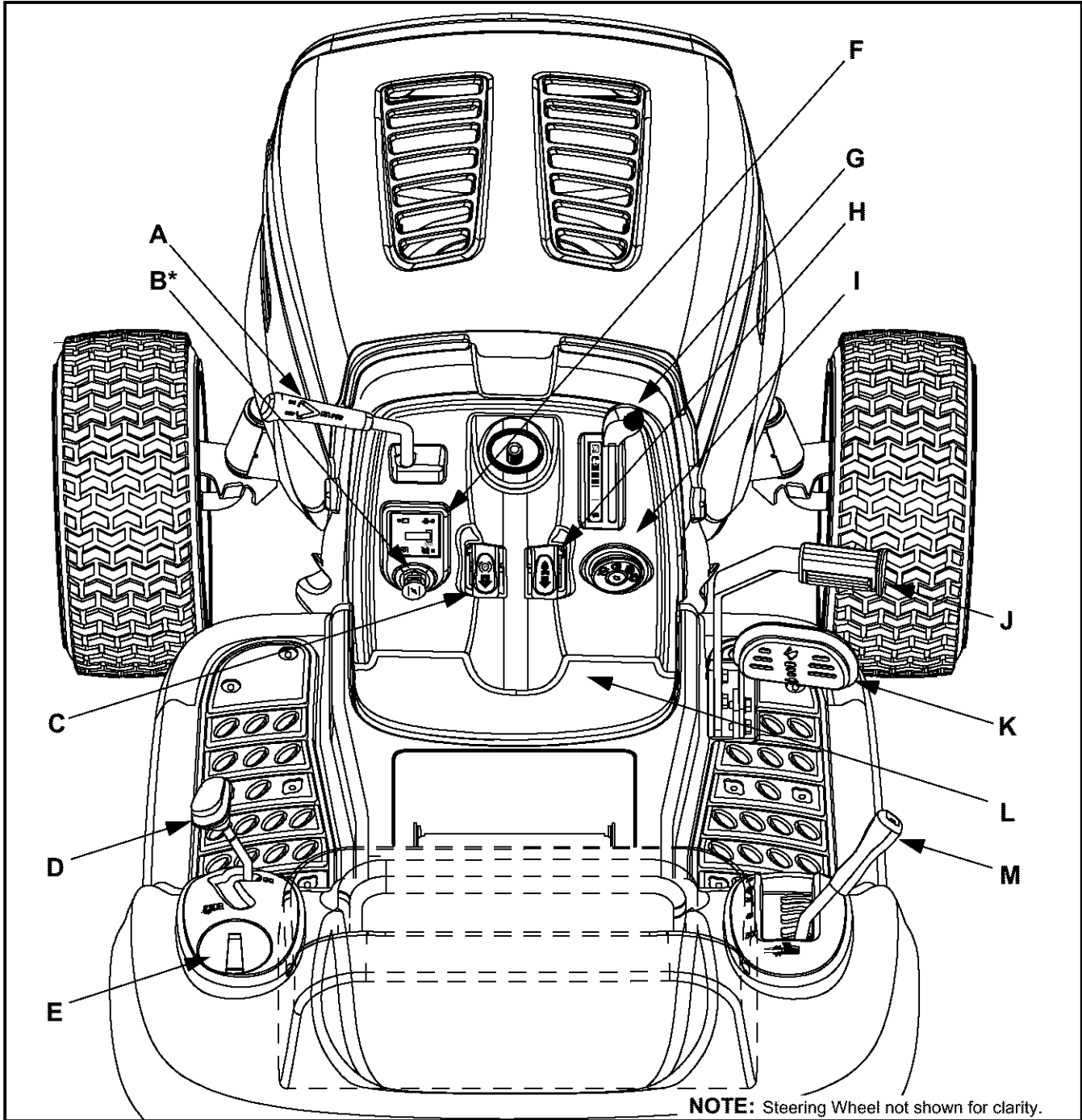

Figure 4

- | | | | |
|---|---------------------------------------|---|-----------------------|
| A | PTO (Power Take-off) Lever | H | Cruise Control Button |
| B | Choke Control | I | Ignition Switch |
| C | Parking Brake Button | J | Brake Pedal |
| D | Shift Lever | K | Drive Pedal |
| E | Cup Holder | L | Cargo Net (not shown) |
| F | Systems Indicator Monitor/ Hour Meter | M | Deck Lift Lever |
| G | Throttle Control Lever | | |

Throttle Control Lever

The throttle control lever is located on the right side of the tractor's dash panel. This lever controls the speed of the engine and, on model LTX-1842, when pushed all the way forward, the choke control also. When set in a given position, the throttle will maintain a uniform engine speed. See Figure 1.

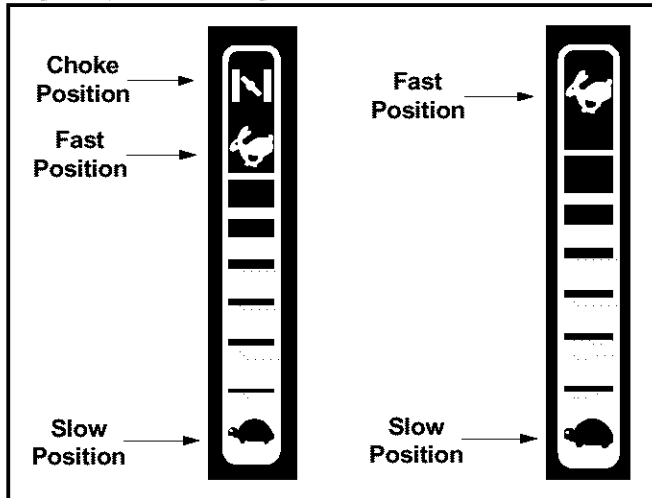
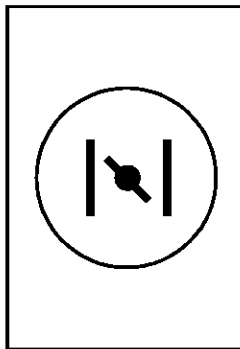

Figure 1

IMPORTANT: When operating the tractor with the cutting deck engaged, be certain that the throttle lever is **always** in the FAST (rabbit) position.

Choke Control

On model LTX-1842, moving the throttle lever all the way forward activates the engine's choke control. On model LTX-2146, the choke control can be found on the left side of the dash panel and is activated by pulling the knob outward. Activating the choke control closes the choke plate on the carburetor and aids in starting the engine. Refer to **Starting The Engine** on page 13 of this manual for detailed starting instructions.



Brake Pedal

The brake pedal is located on the right front side of the tractor above the drive pedal along the running board. The brake pedal can be used for sudden stops or setting the parking brake.

NOTE: The brake pedal must be fully depressed to activate the safety interlock switch when starting the tractor.

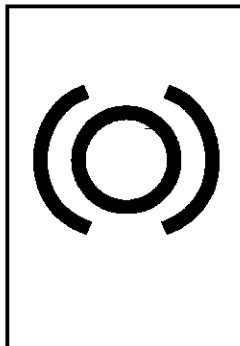

Drive Pedal

The drive pedal is located below the brake pedal on the right front side of the tractor along the running board. Depress the drive pedal with your right foot when the tractor shift lever is in either F (FORWARD) or R (REVERSE) to cause the tractor to move. Ground speed is also controlled with the drive pedal. The further down the pedal is depressed, the faster the tractor will travel. The pedal will return to its original position when it's not depressed.

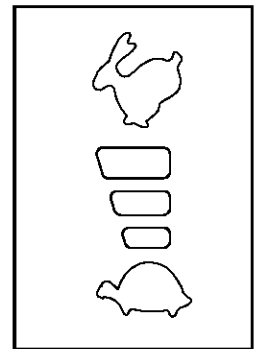

IMPORTANT: Always set the parking brake when leaving the tractor unattended.

Ignition Switch

WARNING: Never leave a running machine unattended. Always disengage PTO, move shift lever into neutral position, set parking brake, stop engine and remove key to prevent unintended starting.

To start the engine, insert the key into the ignition switch and turn clockwise to the **START** position. Release the key into the **ON** position once engine has fired. See Figure 5.

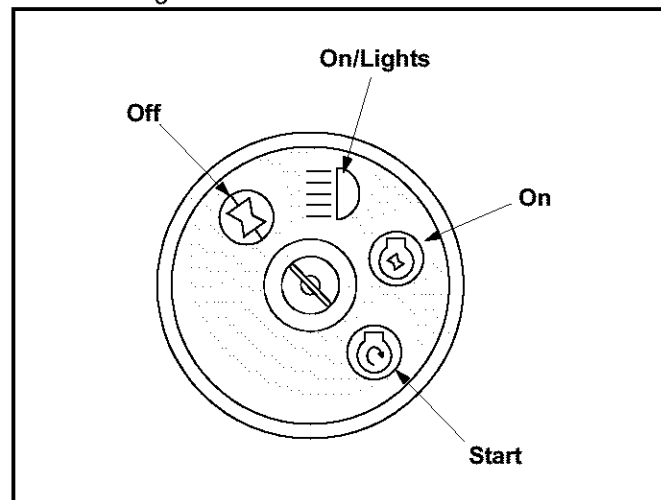

Figure 5

Refer to **Starting The Engine** on page 13 of this manual for detailed starting instructions

The ignition switch is also used to operate the tractor's headlights. Refer to **Operating The Headlights** on page 16 of this manual for detailed instructions.

Systems Indicator Monitor / Hour Meter

Your tractor is equipped with four indicator lights and an hour meter located on the left side of the dash panel. See Figure 2.

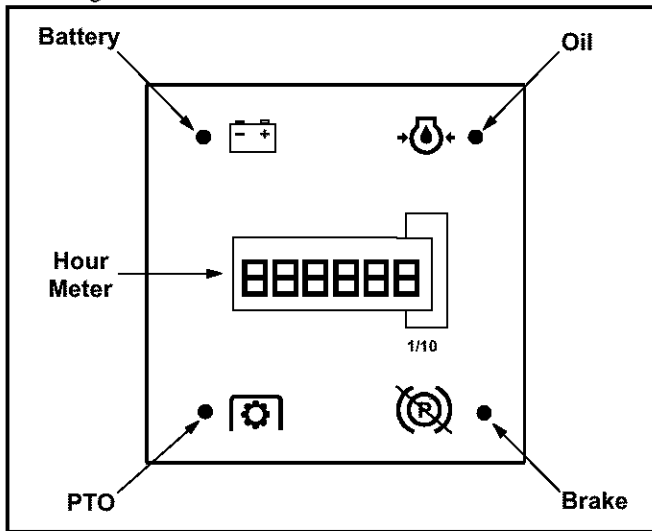

Figure 2

If the Brake light or PTO light illuminates when attempting to start the unit, proceed as follows:

- Brake** — Engage the parking brake.
- PTO** — Move the PTO lever into the disengaged (OFF) position.

It is normal for the Oil light and the Battery light to illuminate while the engine is **cranking**, but if either illuminates while the **engine is running**, proceed as follows:

- Oil**— Stop the tractor immediately and check the crankcase oil level as instructed in the *Briggs & Stratton Operator/Owner Manual* included with your unit. Add oil as required.
- Battery**— If this light illuminates while the engine is running, it indicates that the battery is in need of a charge OR that the engine's charging system is not generating sufficient amperage. Refer to **Battery** on page 20 of this manual for the proper battery charging procedure or have the engine's charging system checked by an authorized service dealer.

The **hour meter** operates whenever the engine is running and records the actual hours of tractor operation.

Deck Lift Lever

Found on your tractor's right fender, the deck lift lever is used to change the height of the cutting deck. To use, move the lever to the left, then place in the notch best suited for your application.

PTO (Power Take-off) Lever

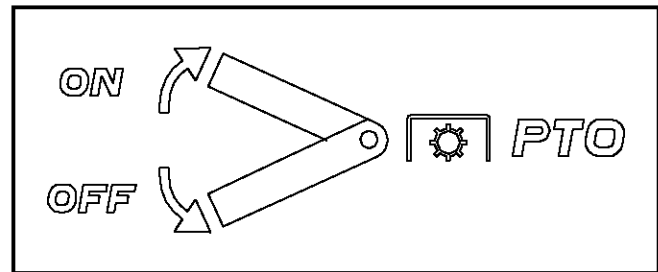

The PTO lever is located on the left side of the dashboard next to the steering wheel. Move the PTO lever forward to engage the power to the cutting deck or other (separately available) attachments; move the PTO lever rearward to disengage the power to the attachments.

NOTE: The PTO lever **must** be in the disengaged (OFF) position when starting the engine, when traveling in reverse and if the operator leaves the seat.

Parking Brake Button

To set the parking brake, fully depress the brake pedal and push the parking brake button in. Hold the button in while taking your foot off the brake pedal. Both the parking button and the brake pedal will then stay depressed. To release the parking brake, depress the brake pedal slightly. The parking brake button will then return to its original position.

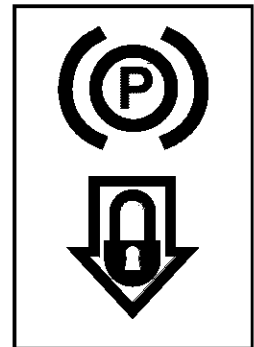

NOTE: The parking brake must be set if the operator leaves the seat with the engine running or the engine will automatically shut off.

IMPORTANT: Always set the parking brake when leaving the tractor unattended.

Cruise Control Button

The cruise control button is located on the tractor dash panel to the left of the ignition switch. Push the cruise control button while traveling forward at a desired speed. While holding the button in, release pressure from the drive pedal. This will engage the cruise control and allow the tractor to remain at that speed without applying pressure to the drive pedal. Depress the brake pedal or the drive pedal to deactivate cruise control. Refer to **Setting the Cruise Control** on page 14 this manual for detailed instructions regarding the cruise control feature.

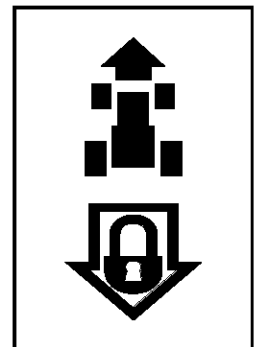

NOTE: Cruise control can NOT be engaged at the tractor's fastest ground speed. If the operator should attempt to do so, the tractor will automatically decelerate to the fastest optimal mowing ground speed.

Cargo Net

Conveniently located on the tractor's dash panel, the cargo net can be used to store personal items while operating the lawn tractor.

Shift Lever

The shift lever is located on the left side of the fender and has three positions, **F** (FORWARD), **N** (NEUTRAL) and **R** (REVERSE). The brake pedal must be depressed and the tractor must not be in motion when moving the shift lever.

IMPORTANT: Never force the shift lever. Doing so may result in serious damage to the tractor's transmission.

SECTION 5: OPERATING YOUR LAWN TRACTOR



WARNING: Read, understand, and follow all instructions and warnings on the machine and in this manual before operating.



WARNING

AVOID SERIOUS INJURY OR DEATH

- GO UP AND DOWN SLOPES, NOT ACROSS.
- AVOID SUDDEN TURNS.
- DO NOT OPERATE THE UNIT WHERE IT COULD SLIP OR TIP.
- IF MACHINE STOPS GOING UPHILL, STOP BLADE(S) AND BACK DOWNHILL SLOWLY.
- DO NOT MOW WHEN CHILDREN OR OTHERS ARE AROUND.
- NEVER CARRY CHILDREN, EVEN WITH BLADES OFF.
- LOOK DOWN AND BEHIND BEFORE AND WHILE BACKING.
- KEEP SAFETY DEVICES (GUARDS, SHIELDS, AND SWITCHES) IN PLACE AND WORKING.
- REMOVE OBJECTS THAT COULD BE THROWN BY THE BLADE(S).
- KNOW LOCATION AND FUNCTION OF ALL CONTROLS.
- BE SURE BLADE(S) AND ENGINE ARE STOPPED BEFORE PLACING HANDS OR FEET NEAR BLADE(S).
- BEFORE LEAVING OPERATOR'S POSITION, DISENGAGE BLADE(S), PLACE THE SHIFT LEVER IN NEUTRAL, ENGAGE BRAKE LOCK, SHUT ENGINE OFF AND REMOVE KEY.

READ OPERATOR'S MANUAL



WARNING: Do not operate the tractor if the interlock system is malfunctioning. This system was designed for your safety and protection.

Setting the Cutting Height

Select the height position of the cutting deck by placing the deck lift lever in any of the six different cutting height notches on the right side of the fender. Then adjust the deck wheels so that they are between ¼-inch and ½-inch above the ground when the tractor is on a smooth, flat surface such as a driveway.



WARNING: Keep hands and feet away from the discharge opening of the cutting deck.

NOTE: The deck wheels are an anti-scalp feature of the deck and are not designed to support the weight of the cutting deck.

Refer to **Leveling the Deck** on page 17 of this manual for more detailed instructions regarding various deck adjustments.

Safety Interlock Switches

This tractor is equipped with a safety interlock system for the protection of the operator. If the interlock system should ever malfunction, do not operate the tractor. Contact an authorized service dealer. The safety interlock system prevents the engine from cranking or starting unless the parking brake is engaged, and the PTO lever is in the disengaged (OFF) position.

- The engine will automatically shut off if the operator leaves the seat before engaging the parking brake.
- The engine will automatically shut off if the operator leaves the tractor's seat with the PTO lever in the engaged (ON) position, regardless of whether the parking brake is engaged.
- The engine will automatically shut off if the PTO lever is moved into the engaged (ON) position with the shift lever in position for reverse travel.

Starting the Engine



WARNING: Do not operate the tractor if the interlock system is malfunctioning. This system was designed for your safety and protection.

NOTE: Refer to the **TRACTOR SET-UP** on page 8 of this manual for Gasoline and Oil fill-up instructions.

- Insert the tractor key into the ignition switch.
- Place the PTO lever in the disengaged (OFF) position.
- Engage the tractor's parking brake.
- Activate the choke control.
- Turn the ignition key clockwise to the **START** position. After the engine starts, release the key. It will return to the **ON** position.

IMPORTANT: Do NOT hold the key in the START position for longer than ten seconds at a time. Doing so may cause damage to your engine's electric starter.

- After the engine starts, deactivate the choke control and place the throttle control in the FAST position.

NOTE: Do NOT leave the choke control on while operating the tractor. Doing so will result in a "rich" fuel mixture and cause the engine to run poorly.

Stopping the Engine



WARNING: If you strike a foreign object, stop the engine, disconnect the spark plug wire(s) and ground against the engine. Thoroughly inspect the machine for any damage. Repair the damage before restarting and operating

- If the blades are engaged, place the PTO lever in the disengaged (OFF) position.
- Turn the ignition key counterclockwise to the OFF position.
- Remove the key from the ignition switch to prevent unintended starting.

Driving The Tractor



WARNING: Avoid sudden starts, excessive speed and sudden stops.



WARNING: Do not leave the seat of the tractor without first placing the PTO lever in the disengaged (OFF) position, depressing the brake pedal and engaging the parking brake. If leaving the tractor unattended, also turn the ignition key off and remove the key.

- Depress the brake pedal to release the parking brake and let the pedal up.
- Move the throttle lever into the FAST (rabbit) position.

IMPORTANT: Do NOT use the shift lever to change the direction of travel when the tractor is in motion. Always use the brake pedal to bring the tractor to a complete stop before shifting.

- To move forward, place the shift lever in the FORWARD position, then slowly depress the drive pedal until the desired speed is achieved.
- To move in reverse, place the shift lever in the REVERSE position, check that the area behind is clear then slowly depress the drive pedal.

Using the Deck Lift Lever

To raise the cutting deck, move the deck lift lever to the left, then place it in the notch best suited for your application.

Engaging the Parking Brake

To engage the parking brake:

- Fully depress the brake pedal and hold it down with your foot while gently pushing the parking brake button inward.
- Hold the parking brake button in while removing your foot from the brake pedal.
- Once engaged, the parking brake button and the brake pedal will lock in the "down" position.

To disengage the parking brake:

- Slightly depress the brake pedal.

NOTE: The parking brake must be engaged if the operator leaves the seat with the engine running or the engine will automatically shut off.

Driving On Slopes

Refer to the **SLOPE GAUGE** on page 7 to help determine slopes where you may operate the tractor safely.



WARNING: Do not mow on inclines with a slope in excess of 15 degrees (a rise of approximately 2-1/2 feet every 10 feet). The tractor could overturn and cause serious injury.

- Mow up and down slopes, NEVER across.
- Exercise extreme caution when changing direction on slopes.
- Watch for holes, ruts, bumps, rocks, or other hidden objects. Uneven terrain could overturn the machine. Tall grass can hide obstacles.
- Avoid turns when driving on a slope. If a turn must be made, turn down the slope. Turning up a slope greatly increases the chance of a roll over.
- Avoid stopping when driving up a slope. If it is necessary to stop while driving up a slope, start up smoothly and carefully to reduce the possibility of flipping the tractor over backward.

Setting The Cruise Control

- Place the shift lever in the FORWARD position, then slowly depress the drive pedal until the desired speed is achieved.
- Lightly depress the cruise control button.
- While continuing to hold the cruise button in, lift your foot from the drive pedal (you should feel the cruise latch engage).
- Once engaged, the cruise control button and the drive pedal will lock in the "down" position, and the tractor will maintain the same forward speed.

NOTE: Cruise control can not be engaged at the tractor's fastest ground speed. If the operator should attempt to do so, the tractor will automatically decelerate to the fastest optimal mowing ground speed.

Disengage the cruise control using one of the following methods:

- Depress the brake pedal to disengage the cruise control and stop the tractor.
- Lightly depress the drive pedal.

To change to the reverse direction when operating with cruise control, depress the brake pedal to disengage the cruise control and bring the tractor to a complete stop. Then place the shift lever in the REVERSE position and depress the drive pedal.

Engaging the PTO

Engaging the PTO transfers power to the cutting deck or other (separately available) attachments. To engage the PTO, proceed as follows:

- Move the throttle control lever to the FAST (rabbit) position.
- Grasp the PTO lever and pivot it all the way forward into the engaged (ON) position.
- Keep the throttle lever in the FAST (rabbit) position for the most efficient use of the cutting deck or other (separately available) attachments

IMPORTANT: The engine will automatically shut off if the PTO is engaged with the shift lever in position for reverse travel. Refer to **Safety Interlock Switches** on page 13.

Operating The Headlights

To turn the tractor's headlights on:

- Start the engine following the instructions earlier in this section.
- Turn the key one notch counterclockwise into the On/Lights position of the ignition switch. Refer to Figure 5.

To turn the tractor's headlights off:

- Turn the key either into the On position (to leave the engine running) or the Off position (to shut the engine off). Refer to Figure 5.

NOTE: *Never move the key into the Start position while the engine is running. Doing so may cause damage to your engine's electric starter.*

Mowing



WARNING: To help avoid blade contact or a thrown object injury, keep bystanders, helpers, children and pets at least 75 feet from the machine while it is in operation. Stop machine if anyone enters the area.

The following information will be helpful when using the cutting deck with your tractor.



WARNING: Plan your mowing pattern to avoid discharge of materials toward roads, sidewalks, bystanders and the like. Also, avoid discharging material against a wall or obstruction which may cause discharged material to ricochet back toward the operator.

- Do not mow at high ground speed, especially if a mulch kit or grass collector is installed.
- For best results it is recommended that the first two laps be cut with the discharge thrown towards the center. After the first two laps, reverse the direction to throw the discharge to the outside for the balance of cutting. This will give a better appearance to the lawn.
- Do not cut the grass too short. Short grass invites weed growth and yellows quickly in dry weather.
- Mowing should always be done with the engine at full throttle.
- Under heavier conditions it may be necessary to go back over the cut area a second time to get a clean cut.
- Do NOT attempt to mow heavy brush and weeds and extremely tall grass. Your tractor is designed to mow lawns, NOT clear brush.
- Keep the blades sharp and replace the blades when worn. Refer to **Cutting Blades** on page 20 of this manual for proper blade sharpening instructions.

Mulching

Your tractor is equipped with a mulch kit which incorporates special blades, already standard on your tractor, in a process of recirculating grass clippings repeatedly beneath the cutting deck. The ultra-fine clippings are then forced back into the lawn where they act as a natural fertilizer. Observe the following points for the best results when mulching.

- Never attempt to mulch if the lawn is damp. Wet grass tends to stick to the underside of the cutting deck preventing proper mulching of the clippings.
- Do NOT attempt to mulch more than 1/3 the total height of the grass or approximately 1-1/2 inches. Doing so will cause the clippings to clump up beneath the deck and not be mulched effectively.
- Maintain a slow ground speed to allow the grass clippings more time to effectively be mulched.
- Always position the throttle control lever in the FAST (rabbit) position and allow it to remain there while mowing. Failing to keep the engine at full throttle places strain on the tractor's engine and does not allow the blades to properly mulch grass.

NOTE: *It is not necessary to remove the discharge chute to operate the mower with the mulch kit installed. Do NOT remove the discharge chute when mulching.*

42-inch Decks

To operate the cutting deck without mulching, simply remove the mulch plug by unthreading the plastic wing nut which fastens it to the cutting deck. This will allow the clippings to discharge out the side. See Figure 6 .

46-inch Decks

The mulch kit is packed separately within the tractor's crate. Observe the instructions included with the mulch kit for the best results when mulching.

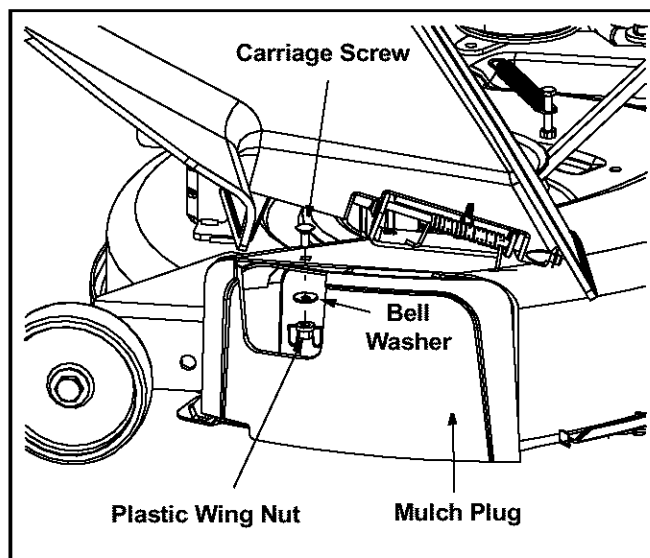

Figure 6

SECTION 6: MAKING ADJUSTMENTS



WARNING: Never attempt to make any adjustments while the engine is running.



WARNING: Disconnect the spark plug wire(s) and ground against the engine before performing any adjustments, repairs or maintenance.

Steering Adjustment

If the tractor turns tighter in one direction than the other, or if the ball joints are being replaced due to damage or wear, the steering drag links may need to be adjusted.

Adjust the drag links so that equal lengths are threaded into the ball joint on the left side and the ball joint on the right side:

- Loosen the jam nut found on the drag link at the rear of the ball joint. See Figure 7.
- Remove the hex nut and lock washer on the top of ball joint. See Figure 7.
- Thread the ball joint toward the jam nut to shorten the drag link. Thread the ball joint away from the jam nut to lengthen the drag link.
- Replace hex nut and lock washer and retighten the jam nut after proper adjustment is achieved.

NOTE: Threading the ball joints too far onto the drag links will cause the front tires to "toe-in" too far. Proper toe-in is between 1/16" and 5/16".

Front tire toe-in can be measured as follows:

- Place the steering wheel in position for straight ahead travel.

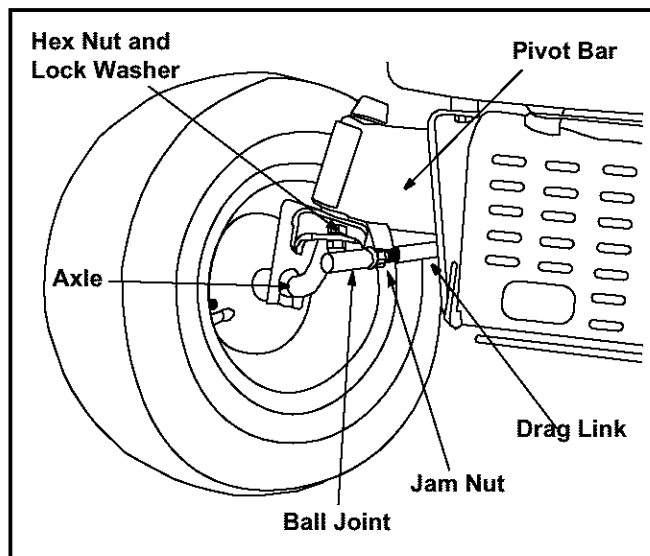

Figure 7

- In front of the axle, measure the distance horizontally from the inside of the left rim to the inside of the right rim. Note the distance.
- Behind the axle, measure the distance horizontally from the inside of the left rim to the inside of the right rim. Note the distance.
- The measurement taken in front of the axle should be between 1/16" and 5/16" less than the measurement taken behind the axle. Adjust if necessary.

Leveling the Deck

NOTE: Check the tractor's tire pressure before performing any deck leveling adjustments. Refer to *Tires* on page 20 for information regarding tire pressure.

Front To Rear

The front of the cutting deck is supported by a stabilizer bar that can be adjusted to level the deck from front to rear. The front of the deck should be between 1/4-inch and 3/8-inch lower than the rear of the deck. Adjust if necessary as follows:

- With the tractor parked on a firm, level surface, place the deck lift lever in the top notch (highest position) and rotate the blade nearest the discharge chute so that it is parallel with the tractor.
- Measure the distance from the front of the blade tip to the ground and the rear of the blade tip to the ground.
- The first measurement taken should be between 1/4" and 3/8" less than the second measurement. Determine the approximate distance necessary for proper adjustment and proceed, if necessary, to the next step.
- Loosen the two jam nuts on the rear side of the deck stabilizer bracket. See Figure 8A.
- Locate the two lock nuts on the opposite side of the stabilizer bracket. See Figure 8A. Tighten the lock nuts to raise the front of the deck; loosen the lock nuts to lower the front of the deck.

- Retighten the two jam nuts loosened earlier when proper adjustment is achieved.

Side to Side

If the cutting deck appears to be mowing unevenly, a side to side adjustment can be performed. Adjust if necessary as follows:

- With the tractor parked on a firm, level surface, place the deck lift lever in the top notch (highest position) and rotate both blades so that they are perpendicular with the tractor.
- Measure the distance from the outside of the left blade tip to the ground and the distance from the outside of the right blade tip to the ground. Both measurements taken should be equal. If they're not, proceed to the next step.
- Loosen, but do NOT remove, the hex cap screw on the left deck hanger bracket. See Figure 8B.
- Balance the deck by using a wrench to turn the adjustment gear (found immediately behind the hex cap screw just loosened) clockwise/up or counterclockwise/down.
- The deck is properly balanced when both blade tip measurements taken earlier are equal.
- Retighten the hex cap screw on the left deck hanger bracket when proper adjustment is achieved.

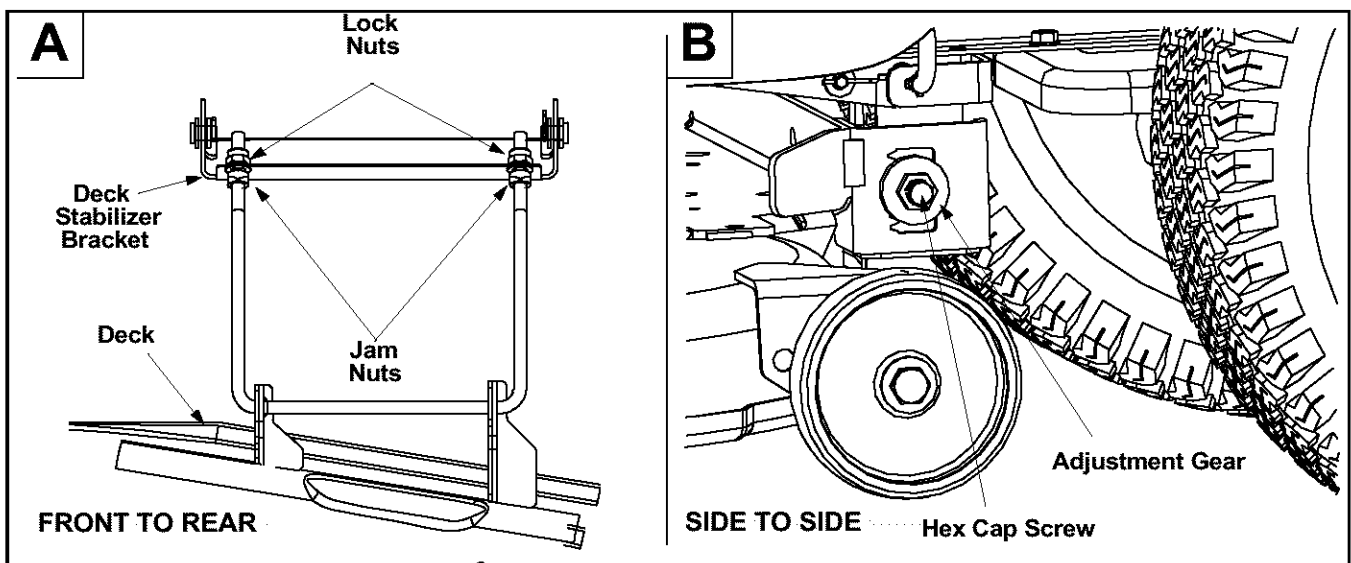

Figure 8

Seat Adjustment

To adjust the position of the seat, loosen the two knobs on the bottom of the seat. See Figure 9. Slide the seat forward or backward as desired. Retighten the two knobs.

Parking Brake Adjustment



WARNING: Never attempt to adjust the brakes while the engine is running. Always disengage PTO, move shift lever into neutral position, stop engine and remove key to prevent unintended starting.

If the tractor does not come to a complete stop when the brake pedal is completely depressed, or if the tractor's rear wheels can roll with the parking brake applied, the brake is in need of adjustment. The brake disc can be found on the right side of the transmission in the rear of the tractor. Adjust if necessary as follows:

- Looking at the transmission from the right side of the tractor, locate the compression spring and brake disc.

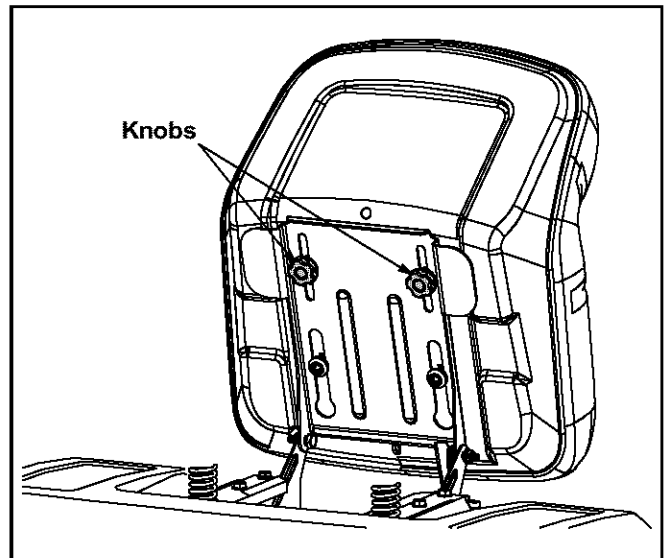

Figure 9

- Loosen, but do NOT remove, the hex nut found on the right side of the brake assembly.
- Using a feeler gauge, set the gap between the brake disc and the brake puck at .011".
- Re-tighten the hex nut loosened earlier.

SECTION 7: MAINTAINING YOUR LAWN TRACTOR



WARNING: Before performing any maintenance or repairs, disengage PTO, move shift lever into neutral position, set parking brake, stop engine and remove key to prevent unintended starting.

Engine

Refer to the *Briggs & Stratton Operator/Owner Manual* for engine maintenance instructions.

Check **engine oil level** before each use as instructed in the *Briggs & Stratton Operator/Owner Manual* packed with your unit. **Follow the instructions carefully.**

Changing Engine Oil

NOTE: Depending on the engine model found on your tractor, it may be necessary to remove the tractor's side panel in order to replace the oil filter (if so equipped).

- Unscrew oil fill cap and remove dipstick from the oil fill tube. See Figure 10.
- Pop open the protective cap on the end of the oil drain valve to expose the drain port. See Figure 10.
- Push the oil drain hose (packed with this manual) onto the oil drain port. Route the opposite end of the hose into an appropriate oil collection container with a capacity of no less than 64 oz.

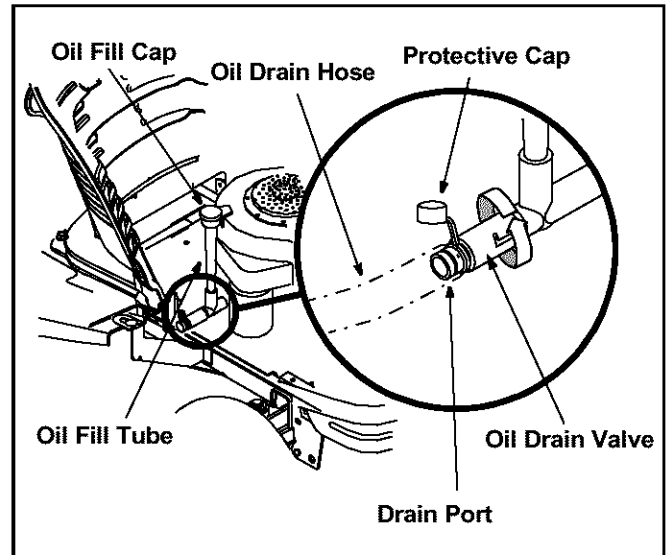

Figure 10

- Push the oil drain valve in slightly, then rotate counterclockwise and pull outward to begin draining oil. See Figure 10.
- Service the **oil filter** (if so equipped) as instructed in the separate *Briggs & Stratton Operator/Owner Manual* packed with your unit.

Perform the above steps in the opposite order after oil has finished draining.

- Refill the engine with new motor oil.

IMPORTANT: Refer to the *Briggs & Stratton Operator/Owner Manual* packed with your unit for information regarding the quantity and proper weight of motor oil.

Air Cleaner

Service the pre-cleaner, if so equipped, and cartridge/air cleaner element as instructed in the *Briggs & Stratton Operator/Owner Manual* packed with your unit.

Spark Plug(s)

The spark plug(s) should be cleaned and the gap reset once a season. Spark plug replacement is recommended at the start of each mowing season. Refer to the *Briggs & Stratton Operator/Owner Manual* for correct plug type and gap specifications.

Lubrication



WARNING: Before lubricating, repairing, or inspecting, always disengage PTO, move shift lever into neutral position, set parking brake, stop engine and remove key to prevent unintended starting.

Engine

Lubricate the engine with motor oil as instructed in the *Briggs & Stratton Operator/Owner Manual* packed with your unit.

Pivot Points & Linkage

Lubricate all the pivot points on the drive system, parking brake and lift linkage at least once a season with light oil.

Rear Wheels

The rear wheels should be removed from the axles once a season. Lubricate the axles and the rims well with an all-purpose grease before re-installing them.

Front Axles

Each end of the tractor's front pivot bar is equipped with a grease fitting. Lubricate with a grease gun after every 25 hours of tractor operation.

Cleaning the Engine And Deck

Any fuel or oil spilled on the machine should be wiped off promptly. Do NOT allow grass, leaves, and dirt to accumulate around the cooling fins of the engine or on any other part of the machine, especially the pulleys and other moving parts.

IMPORTANT: The use of a pressure washer to clean your tractor is NOT recommended. Direct water pressure on electrical components and the engine could result in a shortened life of the tractor and may reduce riding mower serviceability.

Deck Wash System™

Your tractor's deck is equipped with a water port on its surface as part of its deck wash system.

Use the Deck Wash System™ to rinse grass clippings from the deck's underside and prevent the buildup of corrosive chemicals. Complete the following steps **AFTER EACH MOWING:**

1. Drive the tractor to a level, clear spot on your lawn, near enough to a water sillcock (spigot) for your garden hose to reach.

IMPORTANT: Make certain the tractor's discharge chute is directed **AWAY** from your house, garage, parked cars, etc.

2. Disengage the PTO, move the shift lever into the neutral position, set the parking brake, and stop the engine.
3. Thread the hose coupler (packaged with your tractor's Operator's Manual) onto the end of your garden hose.
4. Attach the hose coupler to the water port on your decks surface. See Figure 3.

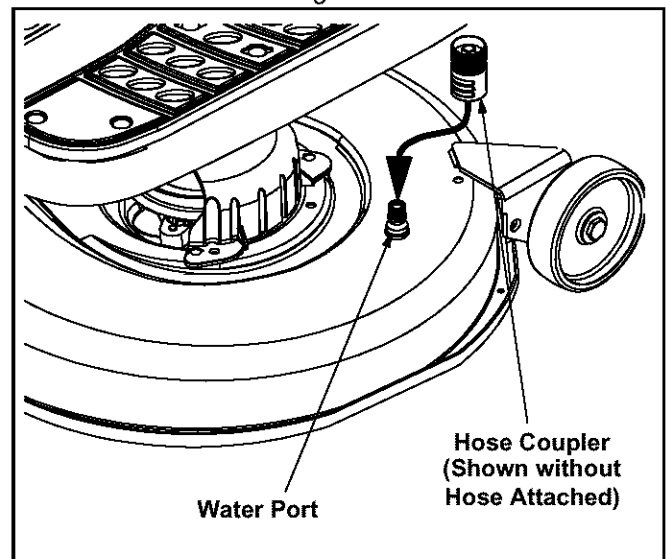

Figure 3

5. Turn the water on.
6. While sitting in the operator's position on the tractor, re-start the engine and place the throttle lever in the FAST (rabbit) position.
7. Engage the tractor's PTO.
8. **Remain in the operator's position** with the cutting deck engaged for a minimum of two minutes, allowing the underside of the cutting deck to thoroughly rinse.
9. Disengage the tractor's PTO.
10. Turn the ignition key to the STOP position to turn the tractor's engine off.
11. Turn the water off and detach the hose coupler from the water port on your decks surface.
12. On model LTX-2146, repeat step 4- step 11 on the opposite side of the cutting deck.

SECTION 8: SERVICE

Battery

The battery is sealed and is maintenance-free. Acid levels cannot be checked.

- Always keep the battery cables and terminals clean and free of corrosive build-up.
- After cleaning the battery and terminals, apply a light coat of petroleum jelly or grease to both terminals.
- Always keep the rubber boot positioned over the positive terminal to prevent shorting.

IMPORTANT: If removing the battery for any reason, disconnect the NEGATIVE (Black) wire from it's terminal first, followed by the POSITIVE (Red) wire. When re-installing the battery, always connect the POSITIVE (Red) wire its terminal first, followed by the NEGATIVE (Black) wire. Be certain that the wires are connected to the correct terminals; reversing them could change the polarity and cause damage to your engine's alternating system.

Charging

If the unit has not been put into use for an extended period of time, charge the battery with an automotive-type 12-volt charger for a minimum of one hour at six amps.



WARNING: Batteries give off an explosive gas while charging. Charge battery in a well ventilated area and keep away from an open flame or pilot light as on a water heater, space heater, furnace, clothes dryer or other gas appliances.

Fuses

Two fuses are installed in your tractor's wiring harness to protect the tractor's electrical system from damage caused by excessive amperage.

If the electrical system does not function, or your tractor's engine will not crank, first check to be certain that the fuse has not blown.

One can be found under the hood mounted behind the top of the dash panel on the support bar.

The other can be found under the seat mounted to the inside of the tractor frame next to the battery tray. Pull the fuse out and inspect it to determine if it is good or blown.



WARNING: Always use a fuse with the same amperage capacity for replacement.

Cutting Deck Removal

To remove the cutting deck, proceed as follows:

- Place the PTO lever in the disengaged (OFF) position and engage the parking brake.
- Lower the deck by moving the deck lift lever into the bottom notch on the right fender.
- On model LTX-1842, remove the PTO belt from around the cutting deck's center pulley. Refer to Figure 14. On model LTX-2146, remove the PTO belt from around the tractor's engine pulley and idler pulley(s). Refer to Figure 15.
- Looking at the cutting deck from the left side of the tractor, locate the deck support pin on the rear left side of the deck.
- Pull the deck support pin outward to release the deck from the deck lift arm. See Figure 11.
- Rotate the pin slightly toward the rear of the tractor and release the pin into the hole provided.
- Repeat the above steps on the tractor's right side.
- Move the deck lift lever into the top notch to raise the deck lift arms up and out of the way.
- Gently slide the cutting deck toward the front of the tractor allowing the hooks on the deck to release themselves from the deck stabilizer rod.
- Gently slide the cutting deck (from the right side) out from underneath the tractor.

Cutting Blades



WARNING: Be sure to shut the engine off, remove ignition key, disconnect the spark plug wire(s) and ground against the engine to prevent unintended starting before removing the cutting blade(s) for sharpening or replacement. Protect your hands by using heavy gloves or a rag to grasp the cutting blade.



WARNING: Periodically inspect the blade adapter and/or spindle for cracks or damage, especially if you strike a foreign object. Replace immediately if damaged.

The blades may be removed as follows.

- Remove the deck from beneath the tractor, (refer to **Cutting Deck Removal** on page 24) then gently flip the deck over to expose its underside.
- Place a block of wood between the center deck housing baffle and the cutting blade to act as a stabilizer. See Figure 13.
- Use a 15/16" wrench to remove the hex flange nut that secures the blade to the spindle assembly. See Figure 13.

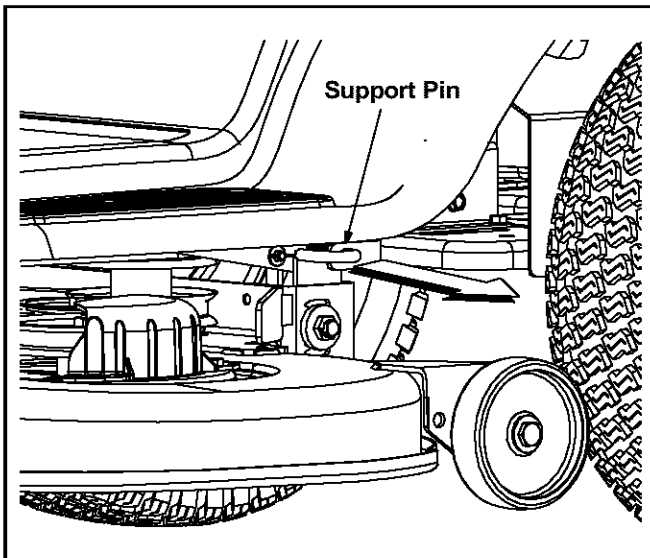

Figure 11

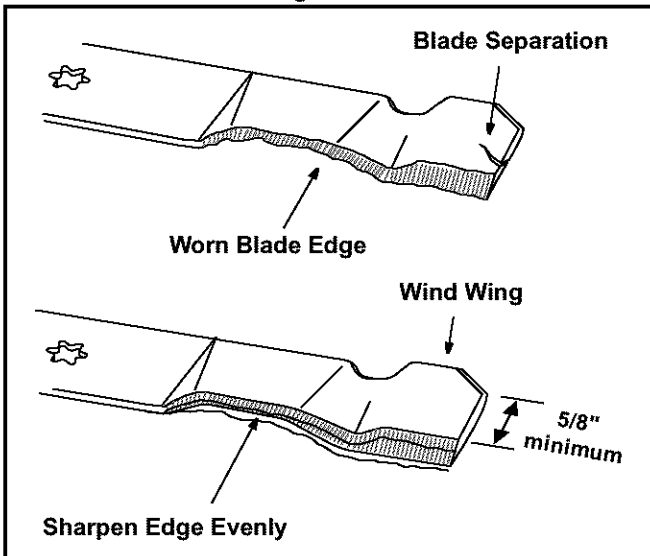

Figure 12

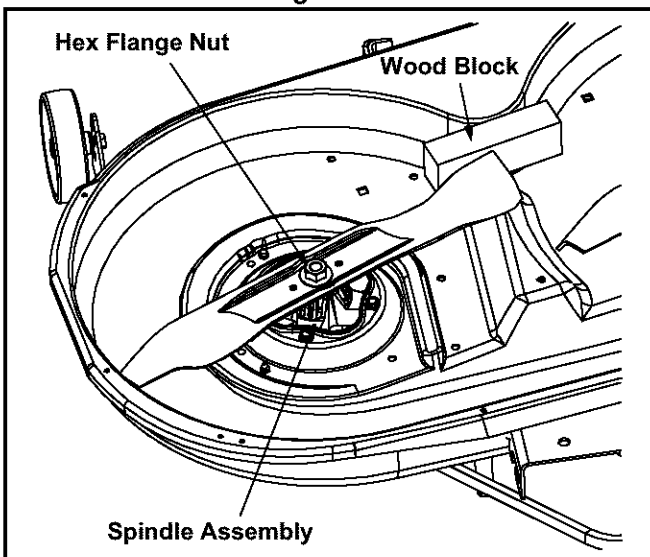

Figure 13

To properly sharpen the cutting blades, remove equal amounts of metal from both ends of the blades along the cutting edges, parallel to the trailing edge, at a 25° to 30° angle. See Figure 12.

IMPORTANT: If the cutting edge of the blade has already been sharpened to within 5/8" of the wind wing radius, or if any metal separation is present, replace the blades with new ones. See Figure 12.

It is important that each cutting blade edge be ground equally to maintain proper blade balance.

A poorly balanced blade will cause excessive vibration and may cause damage to the tractor and result in personal injury.

The blade can be tested by balancing it on a round shaft screwdriver. Grind metal from the heavy side until it balances evenly.

When replacing the blade, be sure to install the blade with the side of the blade marked "Bottom" (or with a part number stamped in it) facing the ground when the mower is in the operating position.

IMPORTANT: Use a torque wrench to tighten the blade spindle hex flange nut to between 70 foot-pounds and 90 foot-pounds.

Changing the Deck Belt & PTO Belt



WARNING: Be sure to shut the engine off, remove ignition key, disconnect the spark plug wire(s) and ground against the engine to prevent unintended starting before removing the belt(s).

All belts on your tractor are subject to wear and should be replaced if any signs of wear are present.

IMPORTANT: The V-belts found on your tractor are specially designed to engage and disengage safely. A substitute (non-OEM) V-belt can be dangerous by not disengaging completely. For a proper working machine, use factory approved belts.

To change or replace the deck belt and PTO belt on your tractor, proceed as follows:

- Lower the deck by moving the deck lift lever into the bottom notch on the right fender.
- Remove the belt guards by removing the self-tapping screws that fasten them to the deck.
- Grasp the rearmost portion of the PTO idler bracket and pivot it toward the discharge chute to relieve tension on the PTO belt.
- Remove the PTO belt from around the engine pulley (and from around the PTO idler pulley(s)).
- Grasp the deck idler pulley and pivot it toward the left to relieve tension on the deck belt.
- Remove the deck belt from around all pulleys, including the deck idler pulley.

- Route the new belts (deck belt first) as shown in Figure 14 or Figure 15.
- Remount the belt guards removed earlier.

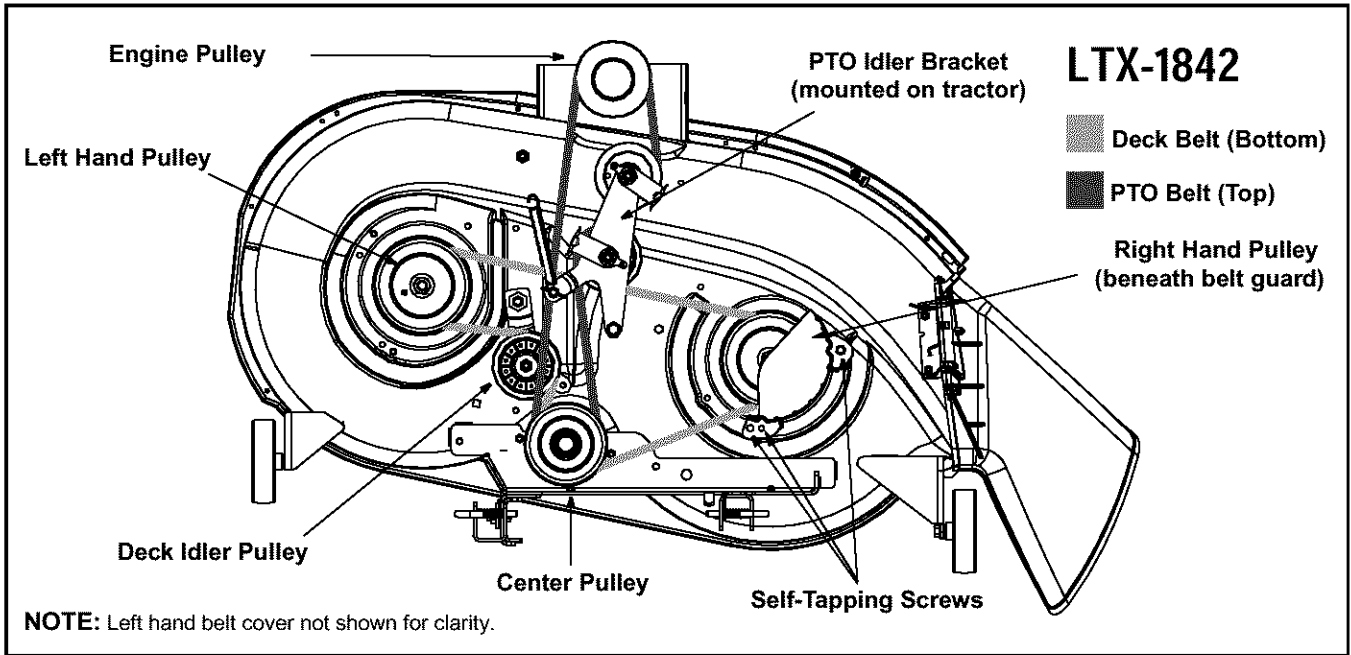

Figure 14

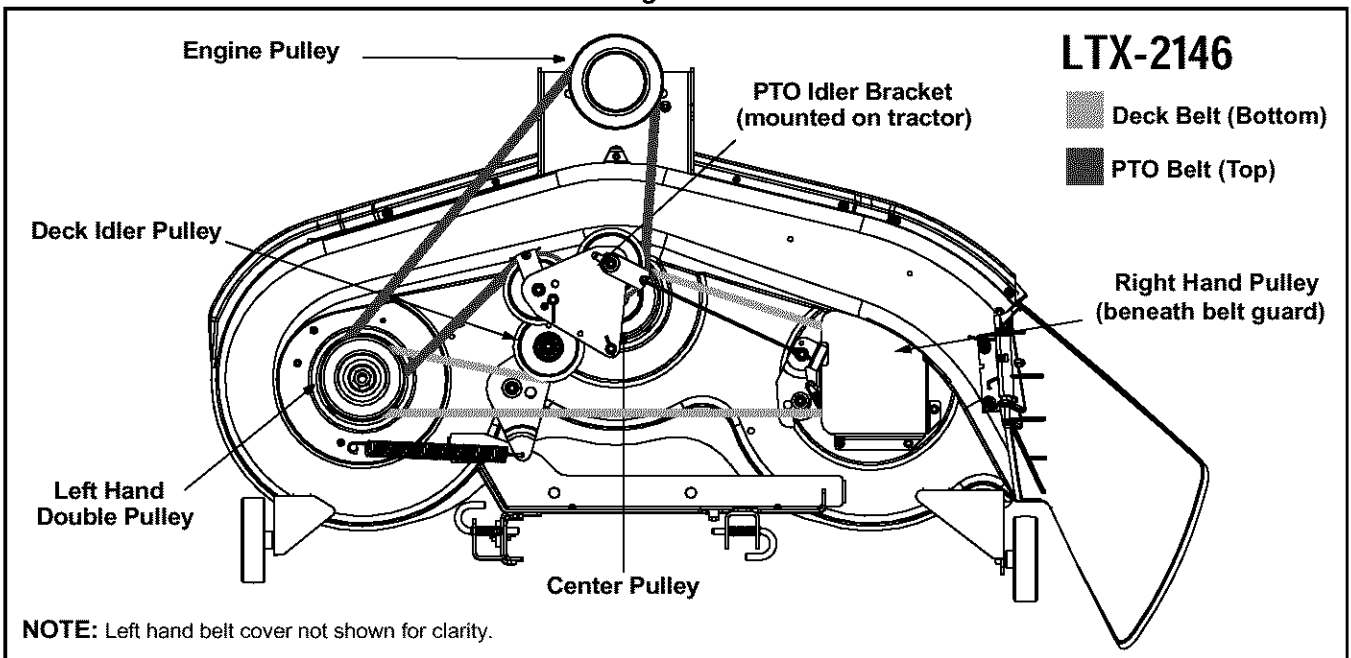

Figure 15

Changing the Transmission Drive Belt



WARNING: Be sure to shut the engine off, remove ignition key, disconnect the spark plug wire(s) and ground against the engine to prevent unintended starting before removing the belt(s)

All belts on your tractor are subject to wear and should be replaced if any signs of wear are present.

IMPORTANT: The V-belts found on your tractor are specially designed to engage and disengage safely. A substitute (non-OEM) V-belt can be dangerous by not disengaging completely. For a proper working machine, use factory approved belts.

To change or replace the drive belt on your tractor, proceed as follows:

- Remove the cutting deck as instructed earlier in this section.

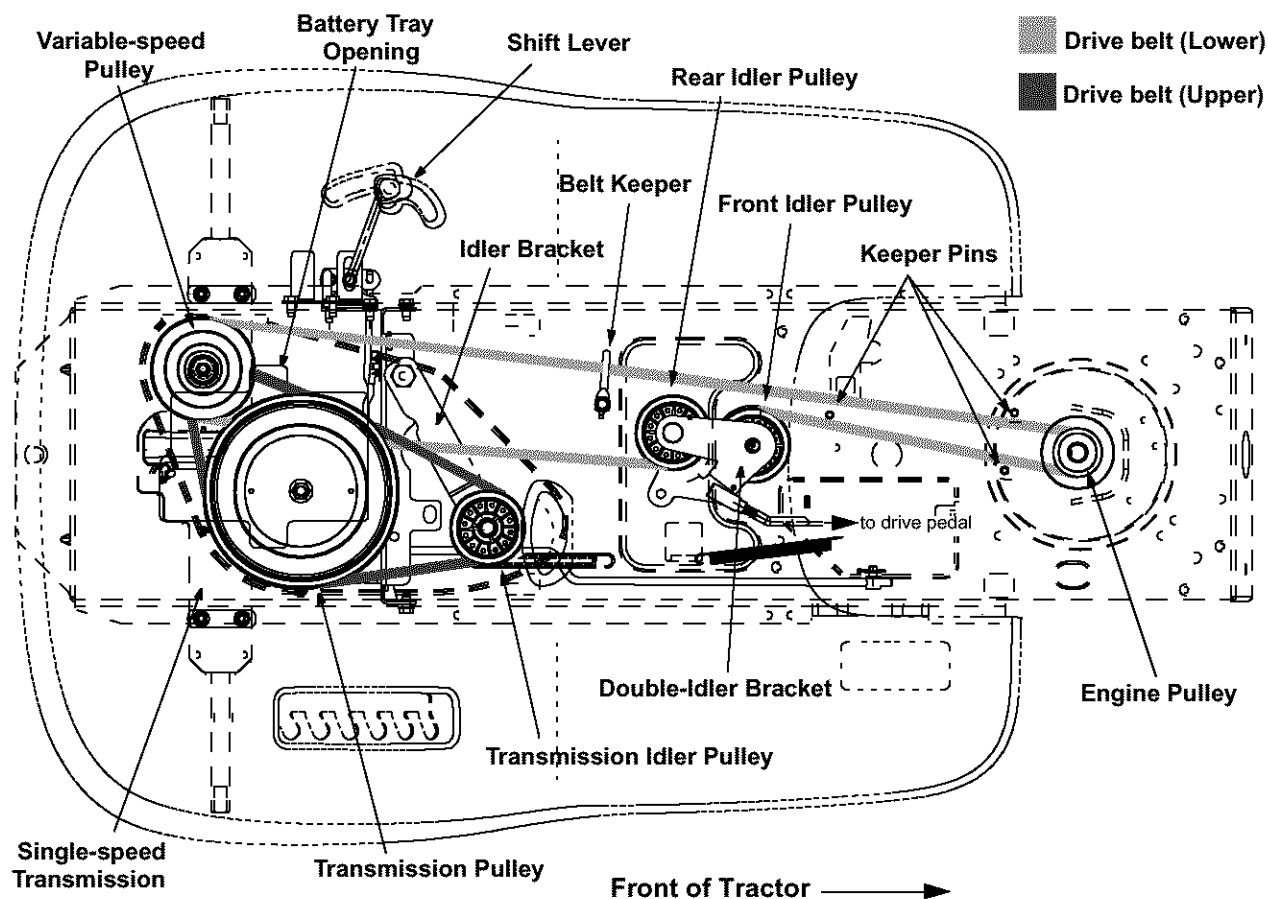

NOTE: View shown from above tractor.

Figure 16

- After disconnecting the battery cables, remove the battery and battery tray from beneath the seat.

IMPORTANT: When removing the battery, disconnect the NEGATIVE (Black) wire from its terminal first, followed by the POSITIVE (Red) wire. Re-install in reverse order.

Upper Drive Belt

- Locate the transmission idler pulley on the upper drive belt by looking through the battery tray opening. See Figure 16.
- Grasp the bracket and pivot the transmission idler pulley toward the rear of the tractor to release tension on the upper drive belt.
- Remove the belt from around the transmission idler pulley.
- Remove the upper drive belt from around the transmission pulley and the variable-speed pulley.

NOTE: Slowly rotate the pulley counterclockwise to roll the belt off of it.

- Remove the upper drive belt by pulling it up through the battery tray opening.
- Reroute the new upper drive belt as shown in Figure 16.

Lower Drive Belt

NOTE: Proper removal of the lower drive belt requires the removal of several tractor components. Read through the following procedure prior to attempting it to determine if you feel you could successfully complete it. If you don't, see an authorized service dealer to have the belt changed.

IMPORTANT: Note the routing of the lower drive belt around all the pulleys and the belt keepers BEFORE performing the following steps.

- Locate the variable-speed pulley through the battery tray opening. See Figure 16.
- Remove the variable-speed pulley by loosening the hex bolt that secures it to the transmission. Use a second wrench to hold the hex nut on the bottom side of the pulley.
- Slide the lower drive belt off of the variable-speed pulley as you lift the pulley up and out through the battery tray opening.
- Remove the rear idler pulley from the double-idler bracket while unrouting the belt from around both the rear and the front idler pulley. Refer to Figure 16.

- Remove the hex bolt from the center of the engine pulley and gently lower it off of the engine crankshaft. Be careful not to lose any washers or spacers which may be found on top of the engine pulley.

IMPORTANT: When remounting the engine pulley (or electric PTO clutch), torque the center hex bolt to between 38 foot-pounds and 50 foot-pounds.

- Remove the drive belt by feeding it from both ends toward the front idler pulley on the double-idler bracket. See Figure 16.
- Reassemble by following the above steps in reverse order.
- Route the replacement belt around the pulleys, belt keepers and keeper pins EXACTLY as the old one was routed. Refer to Figure 16.

The drive pedal is properly adjusted when the hole found in the double-idler bracket has approximately 1-3/8" of travel with ten pounds of pressure applied to the drive pedal. See Figure 17.

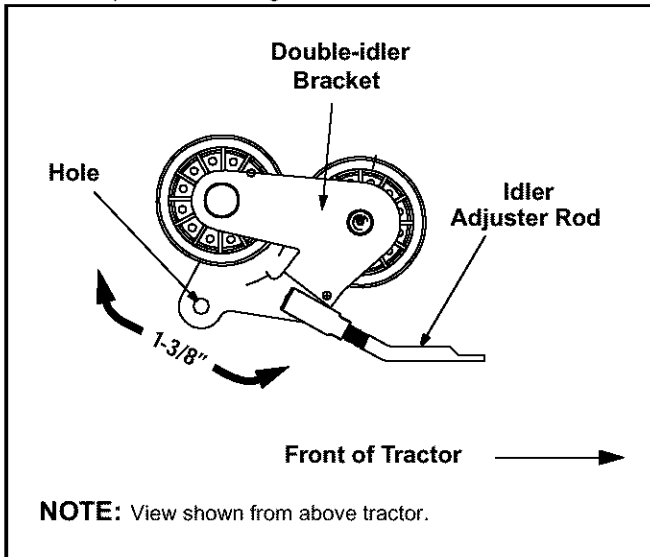

Figure 17

Adjust the drive pedal after replacing the drive belts on your tractor, if necessary, as follows:

- Locate the speed control assembly on the underside of the steering support bracket. See Figure 18.

- Remove both hairpin clips from the pin which is fastened to the speed control assembly (be careful not to lose the small flat washers found on the pin). See Figure 18.
- Remove the drive pedal return spring.

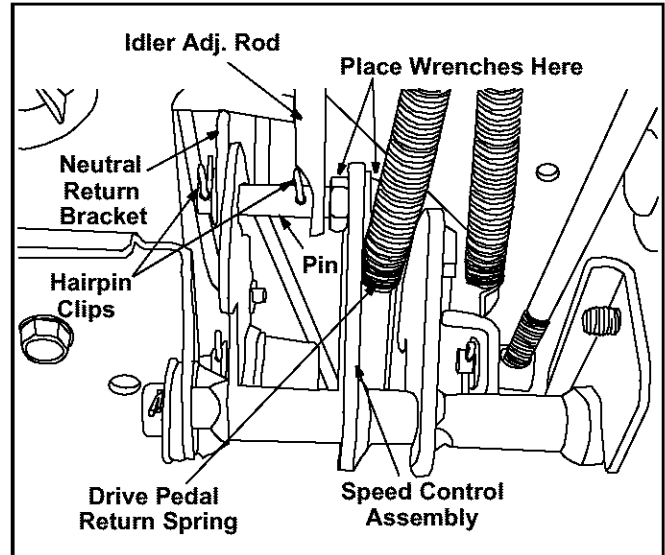

Figure 18

Using two 9/16" wrenches, remove the pin from the speed control assembly. See Figure 18.

Thread the idler adjustment rod inward or outward to lengthen or shorten the travel of the double-idler bracket until proper adjustment is achieved.

- Reassemble by following the above steps in reverse order.

Tires



WARNING: Never exceed the maximum inflation pressure shown on the sidewall of the tire.

The recommended operating tire pressure is approximately 10 psi for the rear tires and approximately 14 psi for the front tires. Refer to the tire sidewall for exact tire manufacturer's recommended or maximum psi. Do not overinflate. Uneven tire pressure could cause the cutting deck to mow unevenly.

SECTION 9: OFF-SEASON STORAGE

Clean and lubricate the tractor as instructed in **Section 7: MAINTAINING YOUR LAWN TRACTOR** on page 18 of this manual before storing for an extended period.



WARNING: Drain fuel only into an approved container outdoors, away from an open flame. Allow engine to cool. Extinguish cigarettes, cigars, pipes, and other sources of ignition prior to draining fuel.

Follow the instructions in the **Service, Storage & Specifications** section of the *Briggs & Stratton* Operator/Owner Manual for proper engine care prior to storing your tractor.



WARNING: Never store the machine or fuel container indoors where there is an open flame, spark or pilot light such as on water heater, furnace, clothes dryer or other gas appliance.

SECTION 10: ATTACHMENTS & ACCESSORIES

The following attachments and accessories are compatible for **Lawn Tractor Models LTX-1842 & LTX-2146**. See the retailer from which you purchased your tractor, an authorized service dealer or phone **1-866-840-6483** for information regarding price and availability.

NOTE: *Lawn tractor models LTX-1842 & LTX-2146 are NOT designed for use with any type of ground-engaging attachments (e.g. tiller or plow). Use of this type of equipment WILL void the tractor's warranty.*

MODEL	DESCRIPTION
OEM-190-116	Mulch Kit (LTX-1842)
OEM-190-118	Mulch Kit (LTX-2146)
OEM-190-180	FastAttach™ Twin Bagger Grass Collector (LTX-1842)
OEM-190-182	FastAttach™ Twin Bagger Grass Collector (LTX-2146)
OEM-190-603	FastAttach™ Grille Guard (mounts on front of tractor)
OEM-190-604	FastAttach™ Yard-Mate™ Storage Container/Toolbox (mounts on rear of tractor)
OEM-190-607	FastAttach™ Deluxe Tractor Sunshade
OEM-190-822	FastAttach™ 46-inch Front Dozer Blade
OEM-190-823	FastAttach™ 42-inch Two-stage Snow Thrower

SECTION 11: TROUBLESHOOTING

Trouble	Possible Cause(s)	Corrective Action
Engine fails to start	PTO lever engaged. Parking brake not engaged. Spark plug wire(s) disconnected. Throttle control lever not in correct starting position. Choke not activated Fuel tank empty, or stale fuel. Blocked fuel line. Faulty spark plug. Engine flooded.	Place PTO lever in disengaged (OFF) position. Engage parking brake. Connect wire(s) to spark plug. Place throttle lever to FAST position. Pull out the CHOKE control. Fill tank with clean, fresh (less than 30 days old) gas. Clean fuel line or replace fuel filter, if so equipped. Clean, adjust gap or replace plug. Crank engine with throttle in FAST position.
Engine runs erratic	Unit running with CHOKE applied. Spark plug wire loose. Blocked fuel line or stale fuel. Vent in gas cap plugged. Water or dirt in fuel system. Dirty air cleaner.	Push CHOKE control in. Connect and tighten spark plug wire. Clean fuel line; fill tank with clean, fresh (less than 30 days old) gasoline. Replace fuel filter, if so equipped. Clear vent or replace cap if damaged. Drain fuel tank. Refill with clean, fresh (less than 30 days old) gasoline. Replace air cleaner cartridge/element or clean pre-cleaner, if so equipped.
Engine overheats	Engine oil level low. Air flow restricted.	Fill crankcase with proper capacity and weight of oil. Clean grass clippings and debris from around the engine's cooling fins and blower housing.
Engine hesitates at high RPM	Spark plug gap too close.	Remove spark plug and reset the gap to .030".
Idles poorly	Spark plug fouled, faulty or gap too wide. Dirty air cleaner.	Replace spark plug. Set plug gap to .030". Replace air cleaner cartridge/element or clean pre-cleaner, if so equipped.
Excessive vibration	Cutting blade loose or unbalanced. Damaged or bent cutting blade.	Tighten blade and spindle. Balance blade. Replace blade.
Mower will not mulch grass	Engine speed too low. Wet grass. Excessively high grass. Dull blade.	Place throttle in FAST (rabbit) position. Do not mow when grass is wet; wait until later to cut. Mow once at a high cutting height, then mow again at desired height or make a narrower cutting swath. Sharpen or replace blade.
Uneven cut	Deck not balanced properly. Dull blade. Uneven tire pressure.	Perform side-to-side deck adjustment. Sharpen or replace blade. Check tire pressure in all four tires.

SECTION 12: PARTS LIST FOR MODELS LTX-1842 & LTX-2146

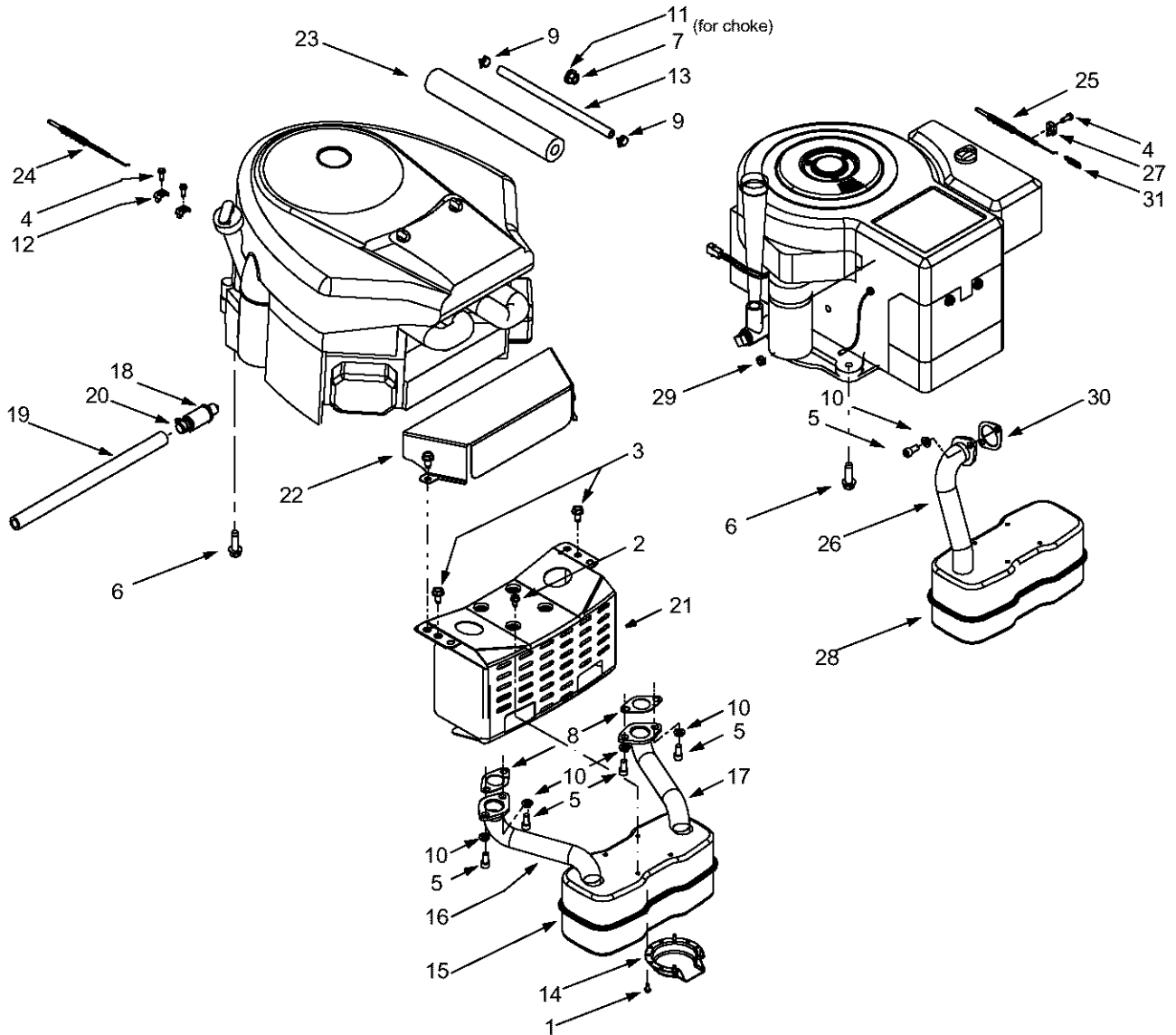

NOTE: Engine accessory parts are applicable to all models except where otherwise noted.

REF. NO.	PART NO.	DESCRIPTION	REF. NO.	PART NO.	DESCRIPTION
1	710-0227	Self-tapping Screw, #8-18 x .5	16	751-0650	RH Exhaust Pipe (Model LTX-2146)
2	710-0599	Self-tapping Screw, 1/4-20 x .5	17	751-0651	LH Exhaust Pipe (Model LTX-2146)
3	710-0604A	Self-tapping Screw, 5/16-18 x .625	18	751-3140	Oil Drain Valve
4	710-1237	Screw, #10-32 x .625	19	751-3141	Oil Drain Hose
5	710-1314A	Socket Cap Screw, 5/16-18 x .625	20	751-3142	Oil Drain Cap
6	710-1315	Self-tapping Screw, 3/8-16 x 1.25	21	783-0615B	Muffler Heat Shield
7	712-3017	Hex Nut, 3/8-16 (Model LTX-2146)	22	783-0625C	Engine Heat Shield (Model LTX-2146)
8	721-0460	Exhaust Gasket (Model LTX-2146)	23	722-0263	Foam (over fuel line) (Model LTX-2146)
9	726-0205	Hose Clamp	24	746-1086	Throttle Cable (Model LTX-2146)
10	736-0119	Lock Washer, 5/16	25	746-1084	Throttle Cable (Model LTX-1842)
11	736-0300	Flat Washer (Model LTX-2146)	26	751-0619	Exhaust Pipe (Model LTX-1842)
12	751B221535	Casing Clamp (Model LTX-2146)	27	751B213146	Casing Clamp (Model LTX-1842)
13	751-0535	Fuel Line Hose	28	751-0617	Muffler, Single Inlet (Model LTX-1842)
14	751-0564	Muffler Deflector	29	712-0271	Hex Sems Nut, 1/4-20 (for starter cable)
15	751-0616	Muffler, Twin Inlet (Model LTX-2146)	30	721-0208	Exhaust Gasket (Model LTX-1842)

Models LTX-1842 & LTX-2146

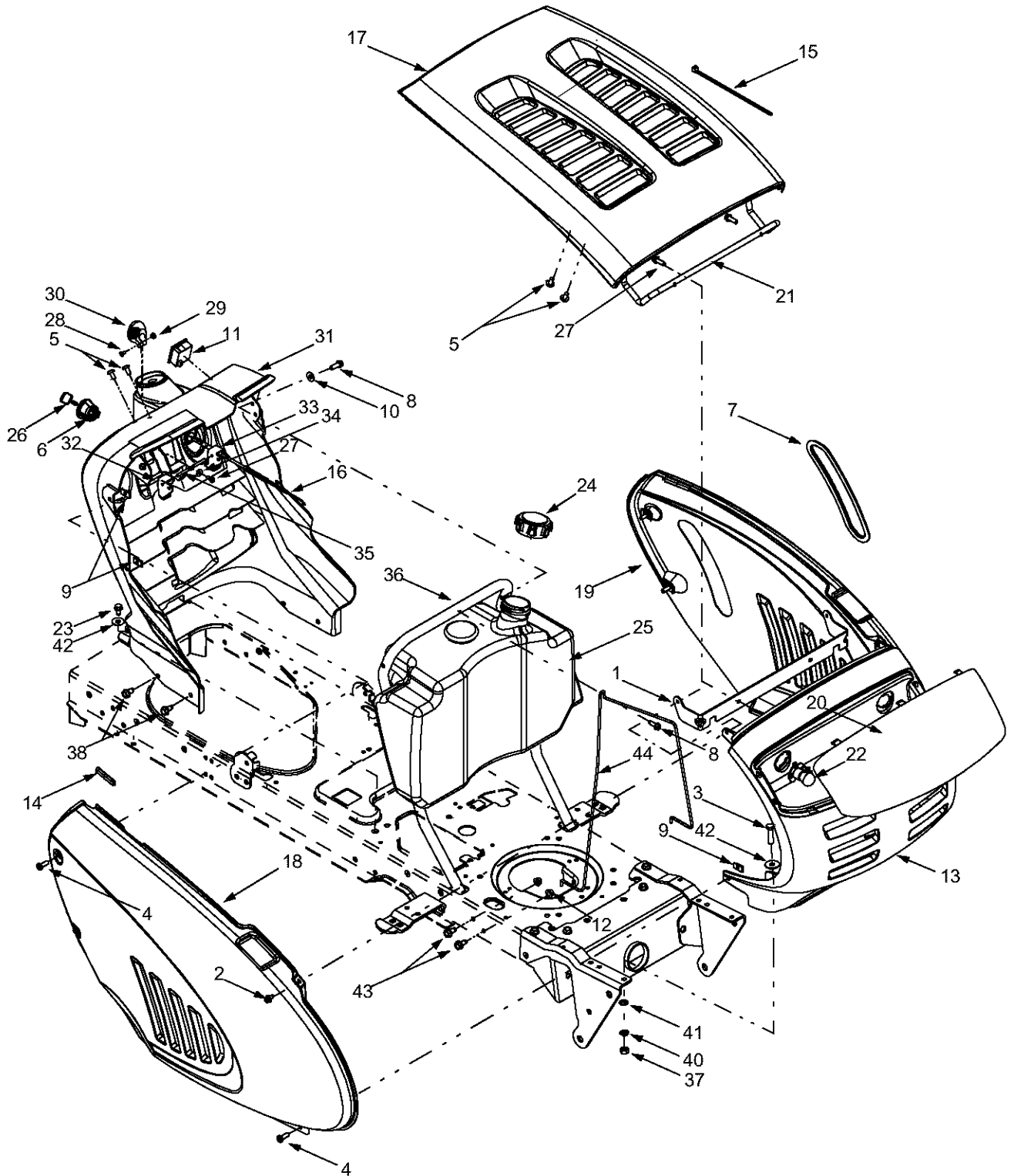

Models LTX-1842 & LTX-2146

REF. NO.	PART NO.	DESCRIPTION
1	783-1346	Grill Support Bracket (9-style)
2	710-0599	Self-tapping Screw, 1/4-20 x .5
3	710-0528	Hex Cap Screw, 5/16-18 x 1.25
4	710-0924	Phillips Pan Screw, 1/4-20 x .75
5	710-1017	Truss Phillips Screw, 1/4-20 x .625
6	725-1741	Ignition Switch
7	735-04019	Side Panel Seal
8	710-0642	Self-tapping Screw, 1/4-20 x .75
9	712-0292	U-type Speed Nut, 1/4-20
10	736-0270	Bell Washer, .265 x .75 x .062
11	725-04036	Systems Indicator Monitor
12	712-3004A	Hex Nut, 5/16-18
13	731-2119A	Grille (9-style)
14	731-0511	Trim Strip, 4
15	725-0157	Cable Tie, 3/16 x .05 x 7.4
16	746-1085	Choke Knob/Cable (Model LTX-2146)
17	783-0783	Hood (9-style)
18	783-0784	RH Side Panel (9-style)
19	783-04200	LH Side Panel (9-style)
20	731-2637	Headlight Lens (9-style)
21	747-2138	Hood Hinge Rod
22	625-0051	Headlight Assembly
23	710-0726	Self-tapping Screw, 5/16-12 x .75
24	751-0603	Fuel Cap
25	751-3213	Fuel Tank, Three-gallon
26	725-1745	Ignition Key w/ plastic cover
	725-1744	Ignition Key w/o plastic cover
27	710-0895	Self-tapping Screw, 1/4-15 x .75
28	710-3217	Truss Phillips Screw, #8-32 x .375
29	712-0142	Hex Nut, #8-32
30	731-1857	Throttle Control Knob
31	631-04037	Dash Panel Assembly w/ Cargo Net
32	731-04217	Cruise Control Button
33	731-04215	Parking Brake Button
34	736-0142	Flat Washer, 9/32 x 1/2 x 1/16
35	747-1196	Brake/Cruise Pivot Rod
36	749-1087C	Dash Support Tube
37	712-3010	Hex Nut, 5/16-18
38	710-1611B	Self-tapping Screw, 5/16-18 x .75
39	726-3046	Ratchet Clip
40	736-0119	Lock Washer, 5/16
41	726-0201	Speed Nut, .3125
42	736-3078	Flat Washer, .349 x 1.0 x .063
43	710-1238	Screw, 5/16-18 x .875 (Grade 5)
44	747-04132	Fule Tank Support Rod
---	629-0469A	Headlight Wire Harness (Not Shown)
---	629-04050	Tractor Wire Harness (Not Shown)

Models LTX-1842 & LTX-2146

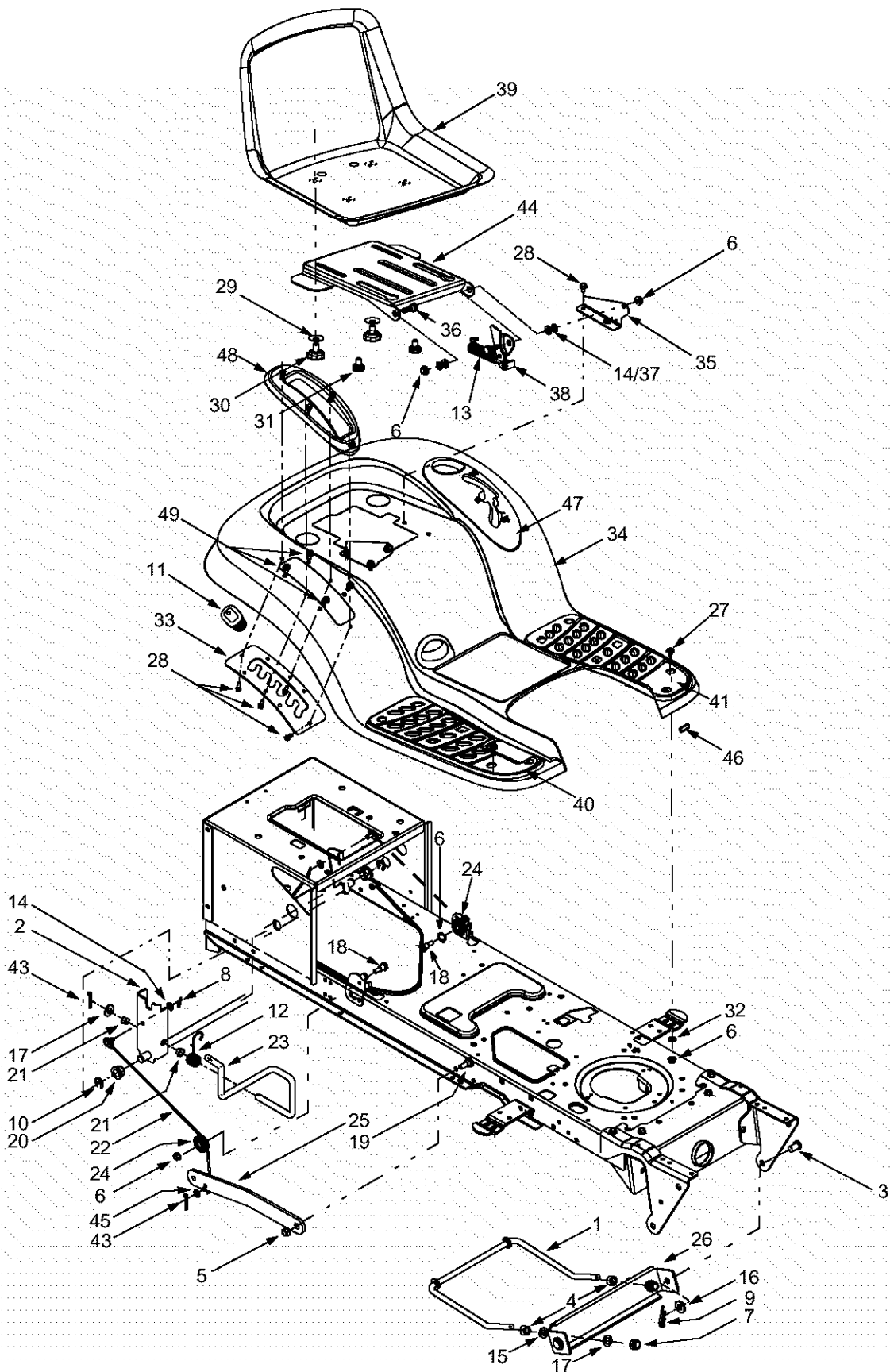

Models LTX-1842 & LTX-2146

REF. NO.	PART NO.	DESCRIPTION
1	747-1130B	Deck Stabilizer Rod
2	683-0197B	Lift Shaft Assembly
3	711-0332	Clevis Pin, .5 x .78
4	712-0206	Hex Nut, 1/2-13
5	712-0431	Flange Lock Nut, 3/8-16
6	712-3004A	Flange Lock Nut, 5/16-18
7	712-3083	Hex Nut, 1/2-13
8	714-0104	Internal Cotter Pin
9	714-0145	Internal Cotter Pin
10	716-0106	E-ring
11	720-0311	Handle Grip
12	732-0874	Torsion Spring
13	732-1184	Extension Spring, .84 x 4.6
14	736-0275	Flat Washer, 5/16
15	736-0921	Lock Washer, 1/2
16	736-3019	Flat Washer, .531 x 1.062 x .134
17	736-3084	Flat Washer, .51 x 1.12 x .06
18	738-0138A	Hex Cap Screw, 5/16-18 x .62
19	738-0143	Shoulder Screw, 3/8-16
20	741-0225	Hex Flange Bearing
21	741-0715	Snap Flange Bearing
22	746-0968	Lift Cable, 16.16 (LTX-1842)
	746-1144	Lift Cable, 15.62 (LTX-2146)
23	747-1111A	Lift Handle
24	756-1154	Roller Pulley
25	783-0678A	Arm Lift
26	783-0720A	Deck Stabilizer Bracket
27	710-0260A	Carriage Bolt, 5/16 x .62
28	710-0604A	Self-tapping Screw, 5/16-18 x .625
29	736-0331	Bell Washer, .390 x 1.13 x .062
30	720-04009	Knob, 3/8-16
31	738-04012	Shoulder Screw
32	736-3078	Flat Washer, .349 x 1.0 x .063
33	783-1010	Lift Adjustment Bracket
34	783-0840A	Fender
35	783-1489	Seat Mounting Bracket
36	738-0296	Shoulder Screw
37	726-0201	Speed Clip
38	783-0209A	Seat Lift Bracket
39	757-04011	Medium Back Seat, Yellow
40	735-0672	RH Foot Pad, Rubber
41	735-0673	LH Foot Pad, Rubber
42	726-3046	Foot Pad Clips
43	714-0111	Cotter Pin
44	783-04081	Seat Pivot Bracket
45	736-0204	Flat Washer, .344 x .62
46	731-0511	Trim Strip
47	731-1990	Lift Lever Cover
48	731-2104B	Shift Lever Cover w/ Cup Holder
49	710-0895	Self-tapping Screw, 1/4-15 x .75

Models LTX-1842 & LTX-2146

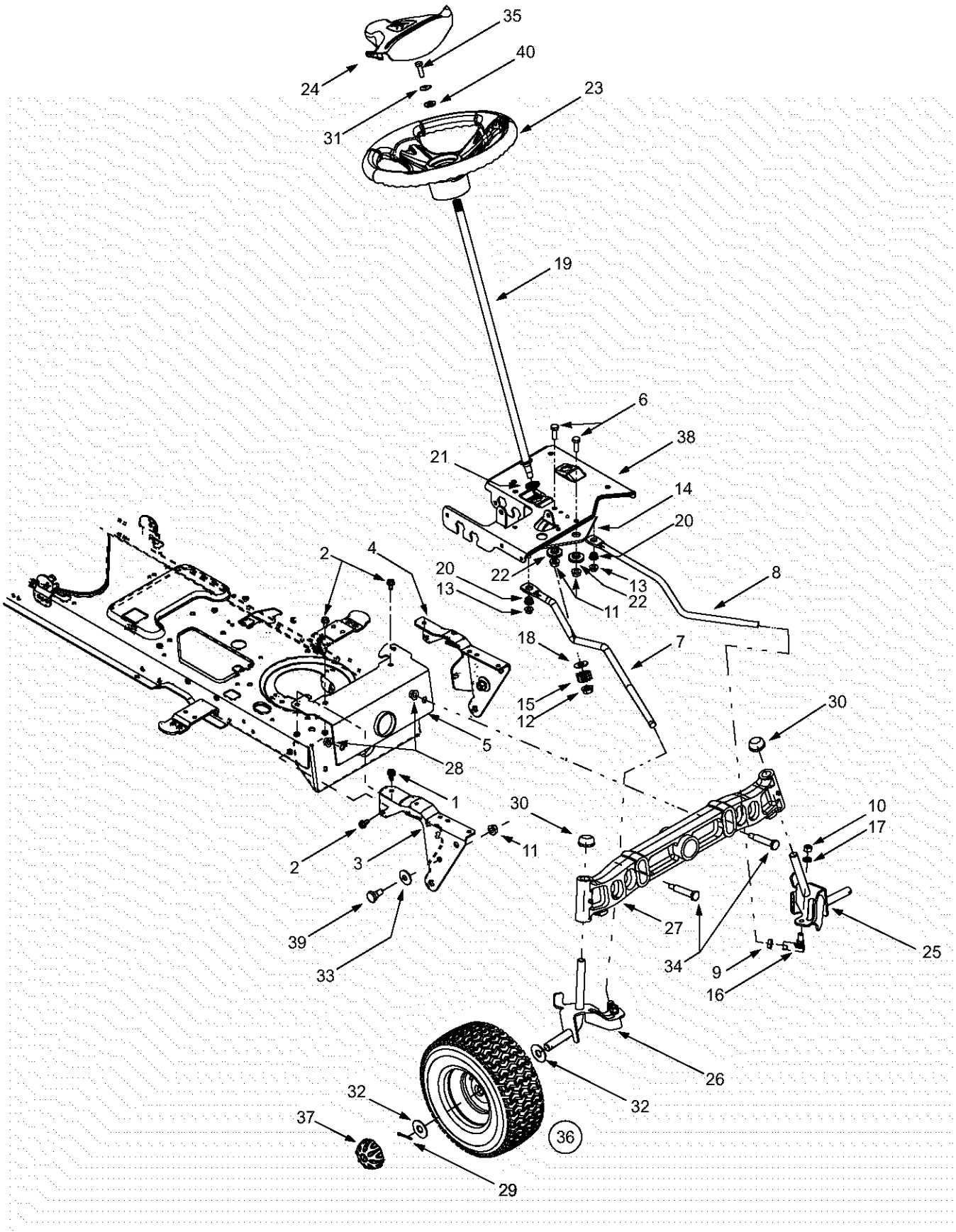

Models LTX-1842 & LTX-2146

REF. NO.	PART NO.	DESCRIPTION
1	710-1260A	Self-tapping Screw, 5/16-18 x .75
2	710-0604A	Self-tapping Screw, 16-18 x .625
3	783-0726B	RH Pivot Support Bracket
4	783-0727A	LH Pivot Support Bracket
5	783-0728	Pivot Bar Bracket
6	710-0514	Hex Cap Screw, 3/8-16 x 1 (Grade 5)
7	711-1408	RH Drag Link
8	711-1409A	LH Drag Link
9	712-0240	Jam Nut, 7/16-20 (Grade 2)
10	712-0241	Hex Nut, 3/8-24 (Grade 2)
11	712-0431	Flange Lock Nut, 3/8-16
12	712-0459	Flange Lock Nut, 7/16-20
13	712-3004A	Flange Lock Nut, 5/16-18
14	717-1550D	Steering Gear, 11/90 Ratio
15	717-1554	Steering Pinion Gear
16	723-0448A	Ball Joint, 7/16-20
17	736-0169	Lock Washer, 3/8
18	736-3084	Flat Washer, .51 x 1.12 x .06
19	738-1001A	Steering Shaft, .625 OD x 24.4
20	741-0475	Plastic Bushing, .38 ID
21	741-0656	Hex Flange Bearing, 5/8
22	738-0372B	Shoulder Spacer, .38 ID
23	631-04008	Steering Wheel, Soft Grip, Three Spoke
24	731-04066	Steering Wheel Cover
25	638-0019A	LH Axle Assembly, .625 Dia.(Model LTX-1842)
	638-0021	LH Axle Assembly .625 / .750 Dia.(Model LTX-2146)
26	638-0020A	RH Axle Assembly, .625 Dia.(Model LTX-1842)
	638-0022	RH Axle Assembly .625 / .750 Dia. (Model LTX-2146)
27	719-0399B	Cast Iron Pivot Bar w/ Fittings, .625 (Model LTX-1842)
	719-0525B	Cast Iron Pivot Bar w/ Fittings, .75 (Model LTX-2146)
28	712-0431	Flange Lock Nut, 3/8-16
29	714-0162	Cotter Pin
30	726-0214	Push Cap, .625 (Model LTX-1842)
	726-0341	Push Cap, .750 (Model LTX-2146)
31	736-0242	Bell Washer, .34 x .872
32	736-0285	Flat Washer, .635 x 1.589 x .06
33	736-0331	Bell Washer, .39 x 1.13 x .062
34	738-1011	Shoulder Screw, .5 x 2.2, 3/8-16
35	710-0643	Hex Bolt, 5/16-18 X 1
36	634-0105A	Wheel Assembly Complete, 15 x 6 x 6
—	634-0172	Rim Only
—	734-0255	Air Valve (Not Shown)
—	734-1731	Tire Only, Square Shoulder
—	741-0487A	Flange Bearing (Not Shown)
—	741-0706	Flange Bearing w/ Fitting (Not Shown)
37	734-2290A	Hub Cap
38	783-0653F	Steering Support Bracket
39	738-0143	Shoulder Screw, 3/8-16
40	736-3004	Flat Washer, .406 x .875 x .105

Models LTX-1842 & LTX-2146

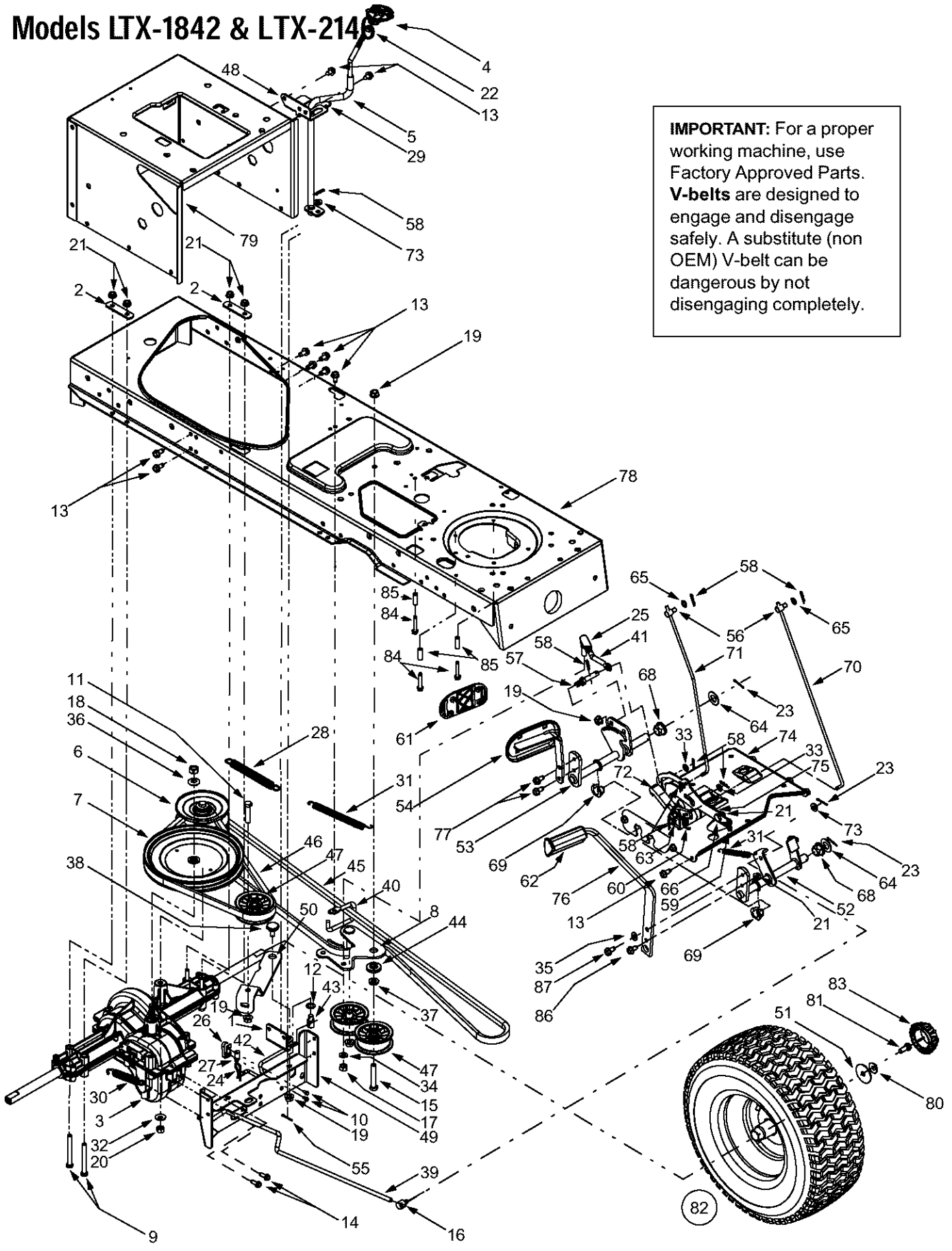

IMPORTANT: For a proper working machine, use Factory Approved Parts. **V-belts** are designed to engage and disengage safely. A substitute (non OEM) V-belt can be dangerous by not disengaging completely.

Models LTX-1842 & LTX-2146

REF. NO.	PART NO.	DESCRIPTION	REF. NO.	PART NO.	DESCRIPTION
1	783-1015	Shift Lever Support	46	754-0468	Upper Drive Belt
2	17840	Transaxle Mounting Bracket	47	756-0981A	Flat Idler, 2.75 OD
3	618-0551A	Single-speed Transmission Assembly	48	783-1016B	Speed Control Rod Bracket
4	631-0009A	Shifter Knob	49	783-0667B	Transmission Torque Bracket
5	647-0045	Shift Lever	50	783-0669	Idler Bracket
6	656-0048	Variable-speed Pulley Assembly	51	736-0430	Flat Washer, .350 x 1.59 x .062
7	656-0051A	Transmission Pulley, 8.5 x .5-36	52	647-0031	Brake Control Assembly
8	683-0251	Double-idler Bracket	53	647-0032	Speed Control Assembly
9	710-0176	Hex Cap Screw, 5/16-18 x 2.75	54	683-0266	Drive Pedal Assembly
10	710-0227	Self-tapping Screw, #8-18 x .5	55	714-0470	Cotter Pin, 1/8 x 1.25
11	710-0347	Hex Cap Screw, 3/8-16 x 1.75	56	711-0736	Ferrule, 1/4-20
12	736-0272	Flat Washer, .51 x 1.0 x .060	57	711-1363	Pin, 3/8-16 x 2.43
13	710-0604A	Self-tapping Screw, 5/16-18 x .625	58	714-0104	Cotter Pin
14	710-0642	Self-tapping Screw, 1/4-20 x .75	59	732-0437	Compression Spring, .34 OD x 1.0
15	710-3011	Hex Cap Screw, 3/8-16 x 2.25	60	732-0955	Extension Spring, .50 OD x 1.41
16	711-0677	Ferrule, 5/16-18	61	735-0662	Drive Pedal Pad
17	712-0241	Hex Nut, 3/8-24	62	735-3049	Brake Pedal Pad
18	712-0378	Hex Nut, 7/16-20	63	736-0142	Flat Washer, .281 x .5 x .063
19	712-0431	Flange Lock Nut, 3/8-16	64	736-0187	Flat Washer, .64 x 1.24 x .06
20	712-3017	Hex Nut, 3/8-16	65	736-0204	Flat Washer, .344 x .062 x .03
21	712-3004A	Flange Lock Nut, 5/16-18	66	738-0155	Shoulder Screw, .437 x 1.62
22	712-3008	Jam Nut, 3/8-16	67	738-0507B	Shoulder Screw, .5 x .434
23	714-0111	Cotter Pin	68	741-0225	Hex Flange Bearing
24	714-0209	Internal Cotter Pin	69	741-3065A	Split Hex Flange Bearing
25	723-3018	Ball Joint	70	747-1137	Cruise Control Rod
26	725-1644	Short Spring Switch	71	747-1138	Brake Lock Control Rod
27	726-0320	Insulator Nut Plate	72	748-0413	Cruise Latch
28	732-0384	Extension Spring, .62 Dia. x 6.12	73	736-0275	Flat Washer, .344 x .688 x .065
29	732-0525	Compression Spring Clip	74	783-0653F	Steering Support Bracket
30	732-0716	Extension Spring, .59 OD x 4	75	783-0732	Drive Lockout Bracket
31	732-0963	Extension Spring, .50 Dia. x 6.37 (hooks to flange, 783-0650, in frame)	76	783-0773	Brake Pedal
32	736-0105	Bell Washer, .401 x .87 x .063	77	710-1260A	Self-tapping Screw, 5/16-18 x .75
33	736-0140	Flat Washer, .385 x .62 x .063	78	683-0304C	Lower Frame Assembly
34	736-0169	Lock Washer, 3/8	79	783-1031A	Hitch Plate
35	736-3008	Flat Washer, .344 x .750 x .120	80	736-0242	Bell Washer, .34 x .872
36	736-0407	Bell Washer, .45 x 1.0 x .602	81	710-0627	Hex Cap Screw, 5/16-24 x .75
37	736-3010	Flat Washer, .407 x .812 x .135	82	634-0104	Wheel Assembly Complete
38	738-0322	Shoulder Screw, .625 x .217		634-0070	Rim Assembly Only
39	747-1122	Brake Rod		734-0255	Air Valve (Not Shown)
40	747-1123A	Belt Guard		734-1730	Tire Only, 20 x 8 x 8, Square Shoulder
41	747-1127	Idler Adjustment Rod, 3/8	83	734-2290A	Deluxe Hub Cap (Ref. 51 Required)
42	747-0047A	Shift Rod	84	710-0809	Self-tapping Screw, 1/4-20 x 1.25
43	711-0736	Adjustment Ferrule, 1/4-20 x 1.0	85	750-0566A	Spacer
44	738-0372A	Shoulder Spacer, .38 ID	86	710-0650	Self-tapping Screw, 5/16-18 x .875
45	754-0467	Lower Drive Belt	87	710-1611B	Self-tapping Screw, 5/16-18 x .75

Models LTX-1842 & LTX-2146

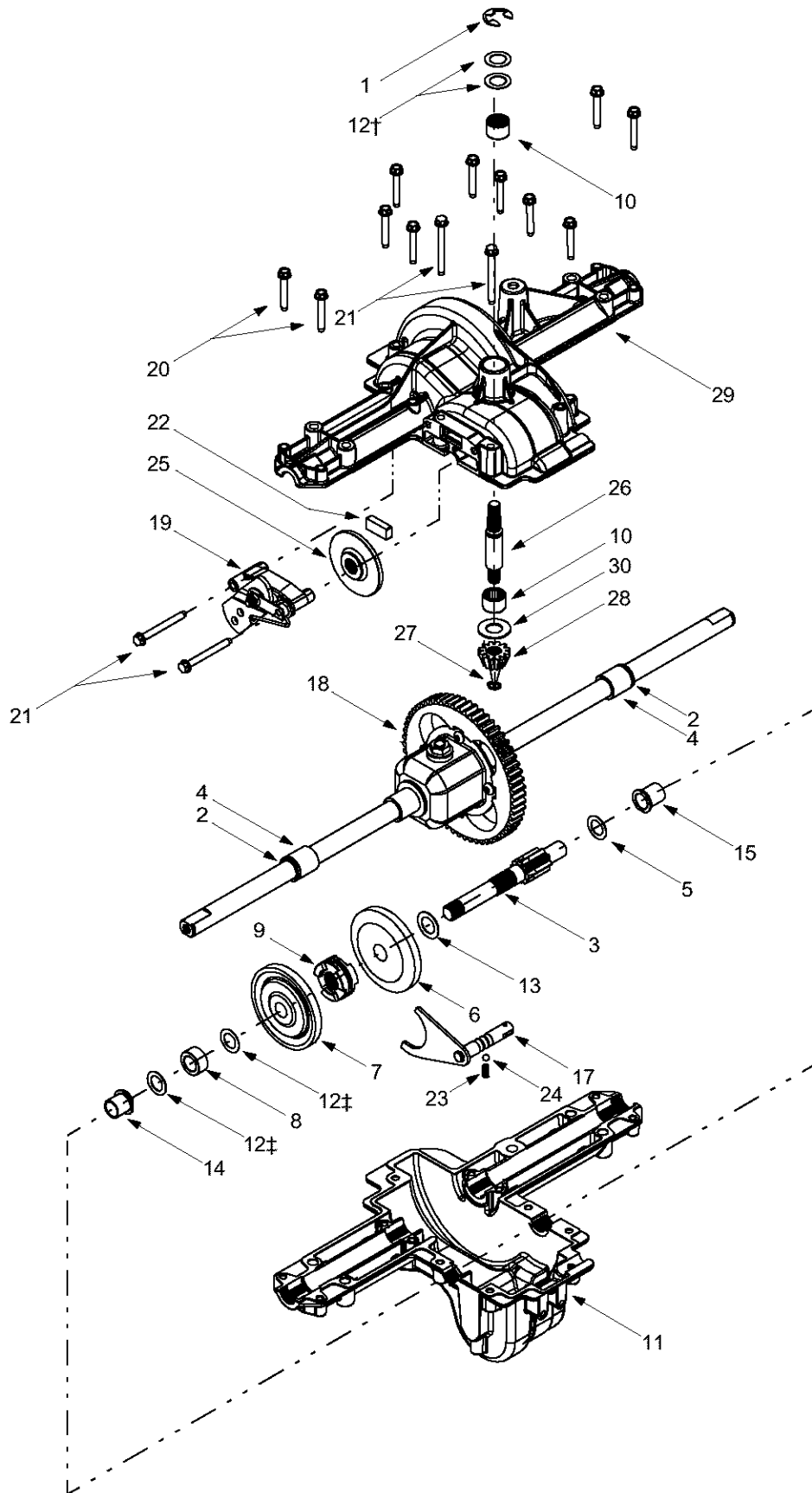

Models LTX-1842 & LTX-2146

REF. NO.	PART NO.	DESCRIPTION
1	716-0231	E-ring, .75
2	721-0338	Seal, .75 x 1.0 x .125
3	711-1431	Drive Shaft
4	741-0340	Sleeve Bearing, .75 x .1.0 x 1.0
5	736-0495	Thrust Washer, 1.0 x .632 x .0
6	717-1362	42-tooth Bevel Gear
7	717-1363	42-tooth Bevel Gear
8	750-1234	Spacer, .633 x 1.0 x .513
9	718-0228	Clutch Collar
10	741-0335	Needle Bearing, .625 x .813 x .495
11	719-0394	Lower Housing
12	736-0336	Flat Washer, 5/8 x 1.0 x .030
	736-0337	Flat Washer, 5/8 x 1.0 x .040
	736-0349	Flat Washer, 5/8 x 1.0 x .020
13	736-0519	Flat Washer, .70 x 1.125 x .031
14	741-0336	Flange Bearing, 5/8 x 3/4 x 3/4
15	741-0337	Flange Bearing, 5/8 x 3/4 x 15/16
16	750-1238	Spacer, .635 x 1.0 x .27
17	611-0133	Detent Shaft Assembly
18	618-0424	Differential Assembly
19	661-0006	Brake Assembly
20	710-1325	Self-tapping Screw, 1/4-20 x 1.625
21	710-1206	Self-tapping Screw, 1/4-20 x 2.375
22	717-0678	Brake Pad
23	732-0863	Compression Spring
24	741-0862	Detent Ball
25	761-0202	Brake Disc
26	711-1430	Input Shaft
27	716-0108	Retaining Ring, .437
28	717-1464	14-tooth Bevel Pinion
29	719-0580	Upper Housing
30	736-0335	Thrust Washer, .635 x 1.25 x .042

†Use applicable flat washer in this application allowing .036/.018 in. end-play.

‡Use applicable flat washer in this application allowing .010/.005 in. end-play.

Models LTX-1842 & LTX-2146

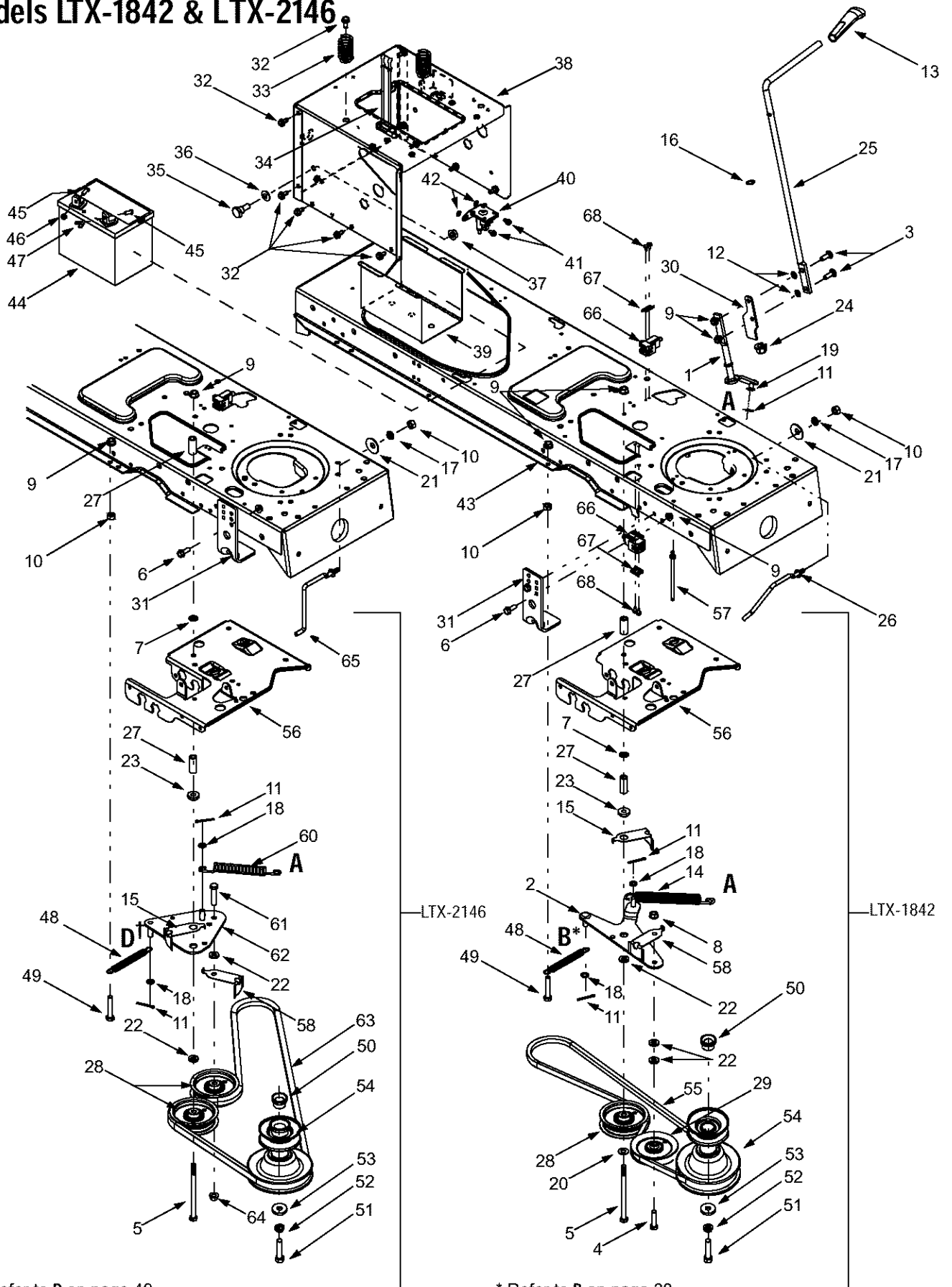

† Refer to D on page 40.

* Refer to B on page 38.

Models LTX-1842 & LTX-2146

REF. NO.	PART NO.	DESCRIPTION	REF. NO.	PART NO.	DESCRIPTION
1	647-0064	PTO Engage Lever Assembly	35	738-1020	Shoulder Screw, .625 x .5, 7/16-20
2	683-0450	PTO Engage Plate Assembly	36	736-0407	Bell Washer, .45 x 1.0 x .062
3	710-0276	Carriage Screw, 5/16-18 x 1.00	37	712-0459	Flange Lock Nut, 7/16-20
4	710-0520	Hex Cap Screw, 3/8-16 x 1.5	38	783-1031A	Hitch Plate
5	710-0831	Hex Cap Screw, 3/8-16 x 5.5	39	783-0349	Battery Tray
6	710-1238	Hex Head Washer Screw, 5/16-18 x .875	40	725-1426	Solenoid, 12-Volt, 100 Amp
7	712-0229	Push Nut, 3/8	41	710-0599	Self Tapping Screw, 1/4-20 x .5
8	712-0431	Flange Lock Nut, 3/8-16	42	736-0222	Lock Washer, 1/4
9	712-3004A	Flange Lock Nut, 5/16-18	43	683-0304C	Lower Frame Assembly
10	712-3010	Hex Nut, 5/16-18	44	725-1706	12-volt Battery, 270 CCA
11	714-0470	Cotter Pin, 1/8 x 1.25	45	710-0751	Hex Cap Screw, 1/4-20 x .62
12	726-0201	Speed Nut, .3125	46	712-0271	Hex Sems Nut, 1/4-20
13	731-2111A	PTO Knob	47	712-3044	Wing Nut, 1/4-20
14	732-1170	Extension Spring, .75 x 6.75	48	732-1165	Extension Spring, .50 x 5.0
15	732-0991A	Belt Guard	49	710-3180	Hex Cap Screw, 5/16-18 x 1.75
16	736-0108	Flat Washer, .510 x .750 x .033	50	750-0956	Spacer Cup
17	736-0119	Lock Washer, 5/16	51	710-3029	Hex Head Cap Screw, 7/16-20 x 1.25
18	736-0140	Flat Washer, .385 x .62 x .063	52	736-0171	Lock Washer, 7/16
19	736-0275	Flat Washer, 5/16	53	736-0322	Flat Washer, .450 x 1.25
20	736-0300	Flat Washer, .406 x .875 x .059	54	756-0982B	Engine Pulley, 3.56 OD x 5.56
21	736-0331	Bell Washer, .39 x 1.13 x .062	55	754-0497	PTO Belt (Model LTX-1842)
22	736-3010	Flat Washer, .407 x .812 x .135	56	783-0653F	Steering Support Bracket
23	738-0372B	Shoulder Spacer, .380	57	711-1044	Keeper Pin, 5/16 x 4.75
24	741-0708	Hex Split Flange Bearing, .5	58	732-1013	Belt Guard
25	747-1112D	PTO Engagement Handle	59	710-3025	Hex Cap Screw, 5/16-18 x .625
26	747-1286A	Belt Keeper Rod	60	732-0944	Extension Spring, .75 x 6.75
27	748-0415B	Spacer, 3/8 x 1.54	61	710-0347	Hex Cap Screw, 3/8-16 x 1.75
28	756-0627B	Idler Pulley, 3.5	62	683-0302	PTO Engagement Plate Assembly
29	756-1208	Idler Pulley, 4.0	63	754-0486A	PTO Belt (Model LTX-2146)
30	783-0744A	Engagement Stop	64	712-0431	Flange Lock Nut, 3/8-16
31	783-0891B	Deck Stop	65	747-1243	Belt Keeper Rod
32	710-0604A	Self Tapping Screw, 5/16-18 x .625	66	725-1657A	Switch
33	732-04035	Compression Spring, 1.28 x 3.125	67	17962	Switch Plate
34	723-0444	Battery Strap	68	710-0224	Screw, #10-16 x .5

Model LTX-1842

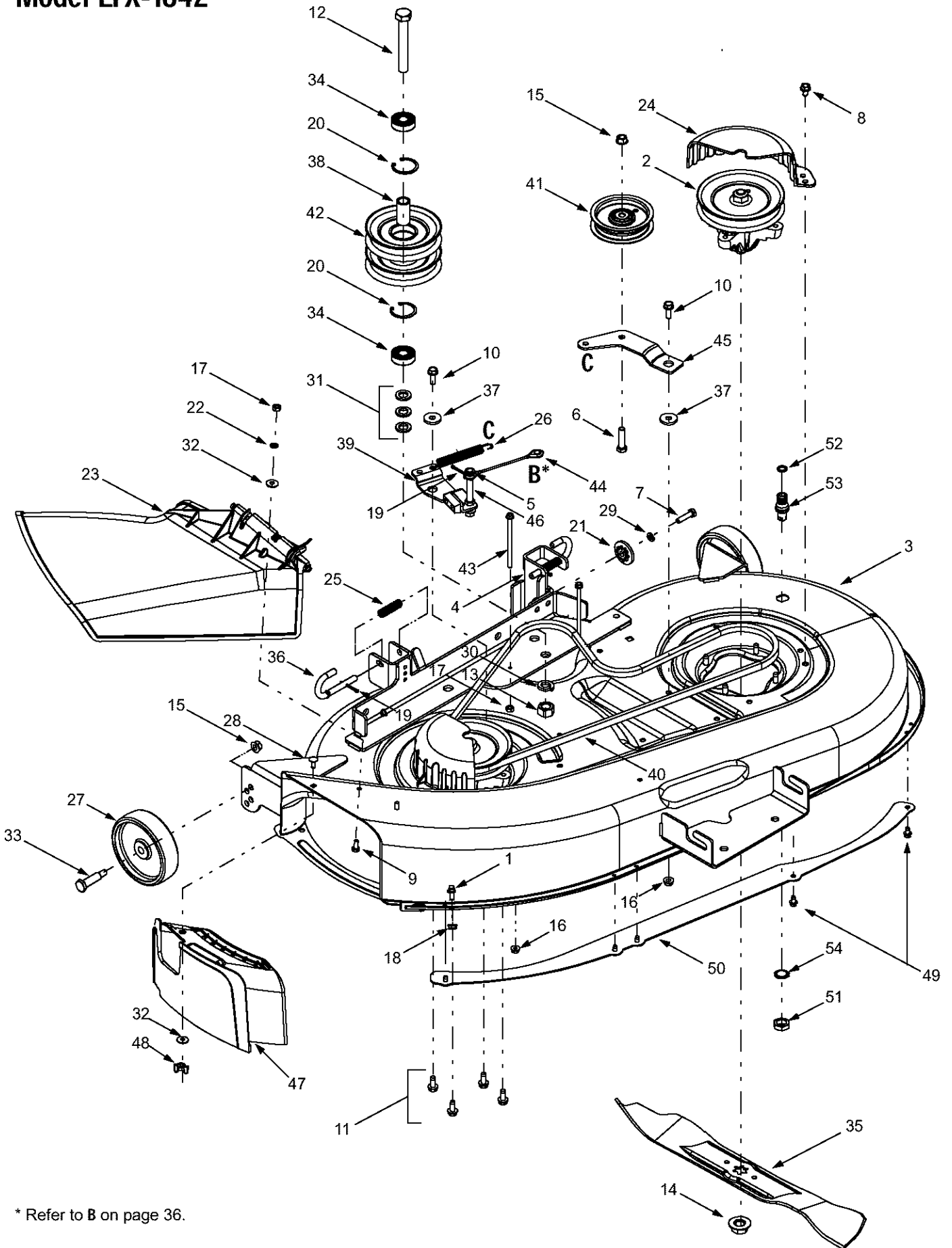

* Refer to B on page 36.

REF. NO.	PART NO.	DESCRIPTION
1	711-04069	Grass Catcher Pin, 1/4-20
2	618-0574	Spindle Assembly, 5.75 Dia. w/ Fitting
	756-0980	Pulley Only
3	683-04051	42-inch Deck Shell
4	683-0254	Deck Adjustment Bracket w/ Weld Nut
5	736-0140	Flat Washer, .385 x .62 x .063
6	710-0520	Hex Cap Screw, 1/4-20 x 1.5
7	710-0528	Hex Cap Screw, 5/16-18 x 1.25
8	710-0726	Self-tapping Screw, 5/16-12 x .75
9	710-0751	Hex Cap Screw, 1/4-20 x .62
10	710-1238	Hex Head Washer Screw, 5/16-18 x .875
11	710-0650	Self-tapping Screw, 5/16-18 x .875
12	710-3151	Hex Cap Screw, 5/8-18 x .875
13	712-0337	Hex Nut, 5/8-18
14	712-0417A	Hex Flange Nut, 5/8-18
15	712-0431	Flange Lock Nut, 3/8-16
16	712-3004A	Flange Lock Nut, 5/16-18
17	712-3006	Hex Nut, 1/4-20
18	712-3027	Hex Flange Lock Nut, 1/4-20
19	714-0470	Cotter Pin, 1/8 x 1.25
20	716-3020	Internal Snap Ring
21	717-1553B	Deck Adjustment Gear
22	726-0233	Push Nut, .25 x .5
23	731-1032B	Side Discharge Chute Assembly
24	731-2486	Belt Cover
25	732-0306	Compression Spring, .406 x .531 x 1.75
26	732-0470A	Extension Spring, .50 x 4.74
27	734-0973	Deck Wheel, 5 x 1.38
28	710-0134	Carriage Screw, 1/4-20 x .5
29	736-0119	Lock Washer, 5/16
30	736-0158	Lock Washer, 5/8
31	736-0162	Flat Washer, .64 x 1.0 x .12
32	736-0270	Bell Washer, .265 x .75 x .062
33	738-0373	Shoulder Screw, .498 x 1.53
34	741-0524	Bearing, .625 x 1.574 x .470
35	742-0616A	Three-in-one Blade, Star Center, 21.23"
36	747-1116	Deck Release Pin
37	748-0331	Shoulder Spacer, .625 x .324
38	750-0932A	Spacer, .635 x .88 x 1.72
39	683-0440	Deck Brake Assembly
40	754-0498	Deck Belt
41	756-0627B	Idler Pulley, 3.5
42	756-1202	Double Pulley, 5.0
43	710-1830	Self-tapping Screw, 1/4-20 x 4.0
44	746-0970	Brake Cable, 5.05
45	783-1291	Idler Bracket
46	711-1534	Pin, 3/8-16, 3/8 x 3.27
47	731-2363	Mulch Plug
48	712-3087	Wing Nut
49	710-0599	Self-tapping Screw, 1/4-20 x .5
50	783-1146A	Deck Skirt
51	712-0641	Hex Nut, M-16 x 1.5
52	721-0417	O-Ring
53	737-04003	Water Nozzle
54	736-0760	Lock Washer, 17 x 23.8 x 1.95

Model LTX-2146

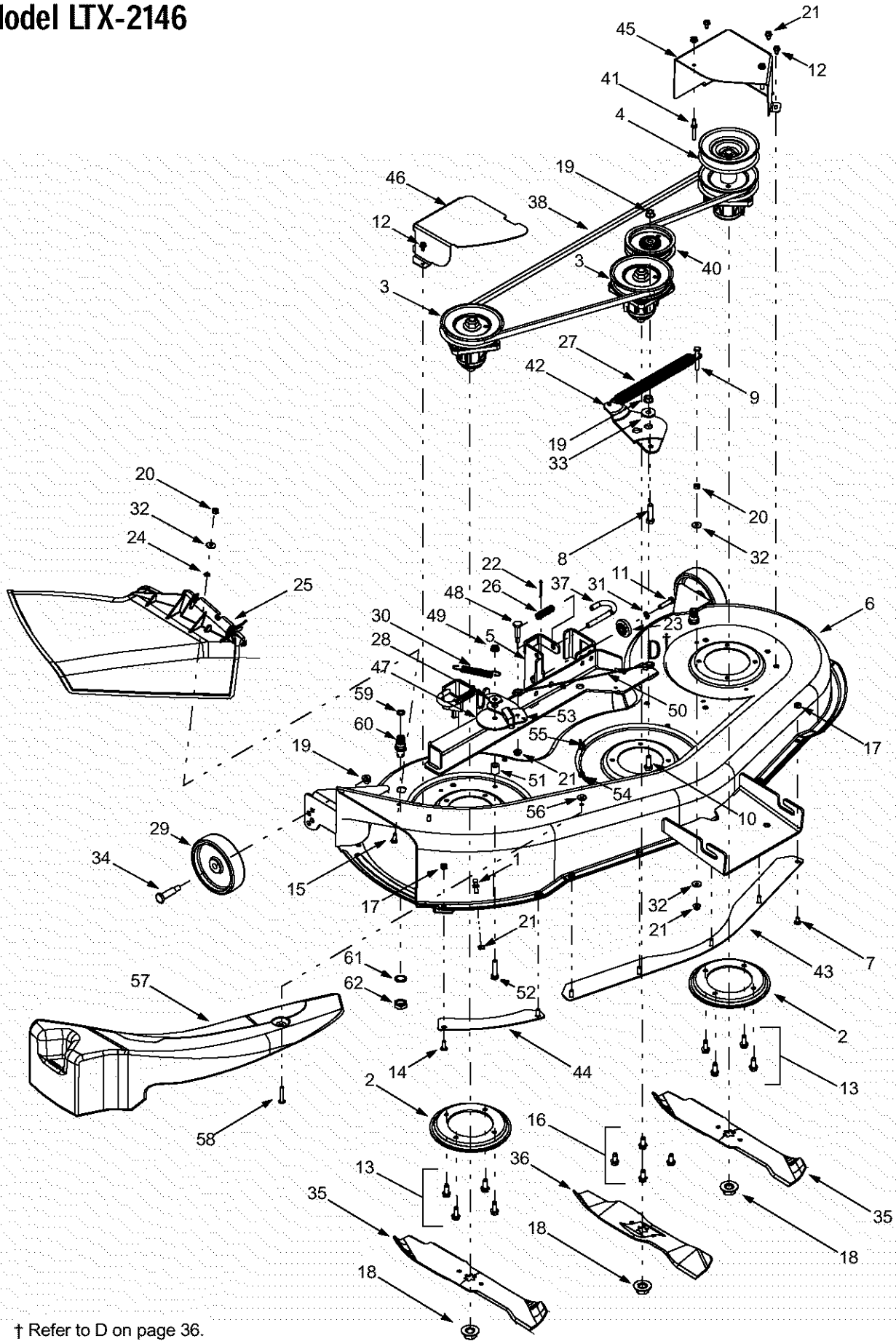

† Refer to D on page 36.

Model LTX-2146

REF. NO.	PART NO.	DESCRIPTION	REF. NO.	PART NO.	DESCRIPTION
1	711-04069	Retainer Hook	31	736-0119	Lock Washer, 5/16
2	17982	Spindle Reinforcement Plate	32	736-0270	Bell Washer, .265 x .75 x .062
3	618-0430A	Spindle Assembly, 5.0 Dia.	33	738-0347	Shoulder Spacer, .625 x 1.16
	756-1187	Pulley Only	34	738-0373	Shoulder Screw
4	618-0595	Double Pulley Spindle Assembly	35	742-0611	Three-in-one Blade, Star Center, 16.28"
	756-1214	Double Pulley Only	36	742-0612	Three-in-one Blade, Star Center, 14.88"
5	683-0254	Deck Adjustment Bracket Assembly	37	747-1116	Deck Release Pin
6	683-04052	46-inch Deck Shell	38	754-0349	Deck Belt, Poly
7	710-0167	Carriage Screw, 1/4-20 x .50	39	738-3056	Shoulder Screw, 1/2-2.5
8	710-0344	Hex Cap Screw, 3/8-16 x 1.5	40	756-0627B	Idler Pulley, 3.5
9	710-0501	Hex Cap Screw, 1/4-20 x 2.0	41	711-0993	Belt Guard Pin
10	710-0514	Hex Cap Screw, 3/8-16 x 1.0	42	783-0139A	Idler Bracket
11	710-0528	Hex Cap Screw, 5/8-18 x 1.25	43	783-0141	Center Deck Skirt
12	710-0599	Self-tapping Screw, 1/4-20 x .5	44	783-0142	RH Deck Skirt
13	710-0650	Self-tapping Screw, 15/16-18 x .875	45	783-1348	LH Belt Cover
14	710-0703	Hex Screw, 1/4-20 x .75	46	17258C	RH Belt Cover
15	710-0751	Hex Cap Screw, 1/4-20 x .62	47	736-0416	Flat Washer, .320 x 3.0 x .125
16	710-1260A	Self-tapping Screw, 5/16-18 x .75	48	738-0572	Shoulder Screw, .374 x 1.16
17	712-0271	Hex Sems Nut, 1/4-20	49	712-3004A	Hex Nut, 5/16-18
18	712-0417A	Hex Flange Nut, 5/8-18	50	746-1107	Bracket Cable, 12"
19	712-0431	Flange Lock Nut, 3/8-16	51	750-0807	Spacer, .385 x .625 x .70
20	712-3006	Hex Nut, 1/4-20	52	710-0805	Hex Cap Screw, 5/16-18 x 1.5
21	712-3027	Hex Flange Lock Nut, 1/4-20	53	17116	Deck Brake Assembly
22	714-0470	Cotter Pin, 1/8 x 1.25	54	712-3006	Hex Nut, 1/4-20
23	717-1553A	Deck Adjustment Gear	55	712-3087	Wing Nut, 1/4-20
24	726-0233	Push Nut, .25 x .5	56	736-0173	Flat Washer, .28 x .74 x .063
25	731-1032B	Side Discharge Chute Assembly	57	731-1636	Mulch Plug
26	732-0306	Compression Spring, .406 x .531 x 1.75	58	710-0578	Screw, 1/4-20 x 1.5
27	732-0594A	Extension Spring, .91 x 7.3	59	721-0417	O-Ring
28	748-0324	Shoulder Spacer	60	737-04003	Water Nozzle
29	734-0973	Deck Wheel, 5 x 1.38	61	736-0760	Lock Washer, 17 x 23.8 x 1.95
30	732-0429A	Extension Spring, .5 x 3.97	62	712-0641	Hex Nut, M-16 x 1.5

IMPORTANT: For a proper working machine, use Factory Approved Parts. **V-belts** are designed to engage and disengage safely. A substitute (non OEM) V-belt can be dangerous by not disengaging completely.

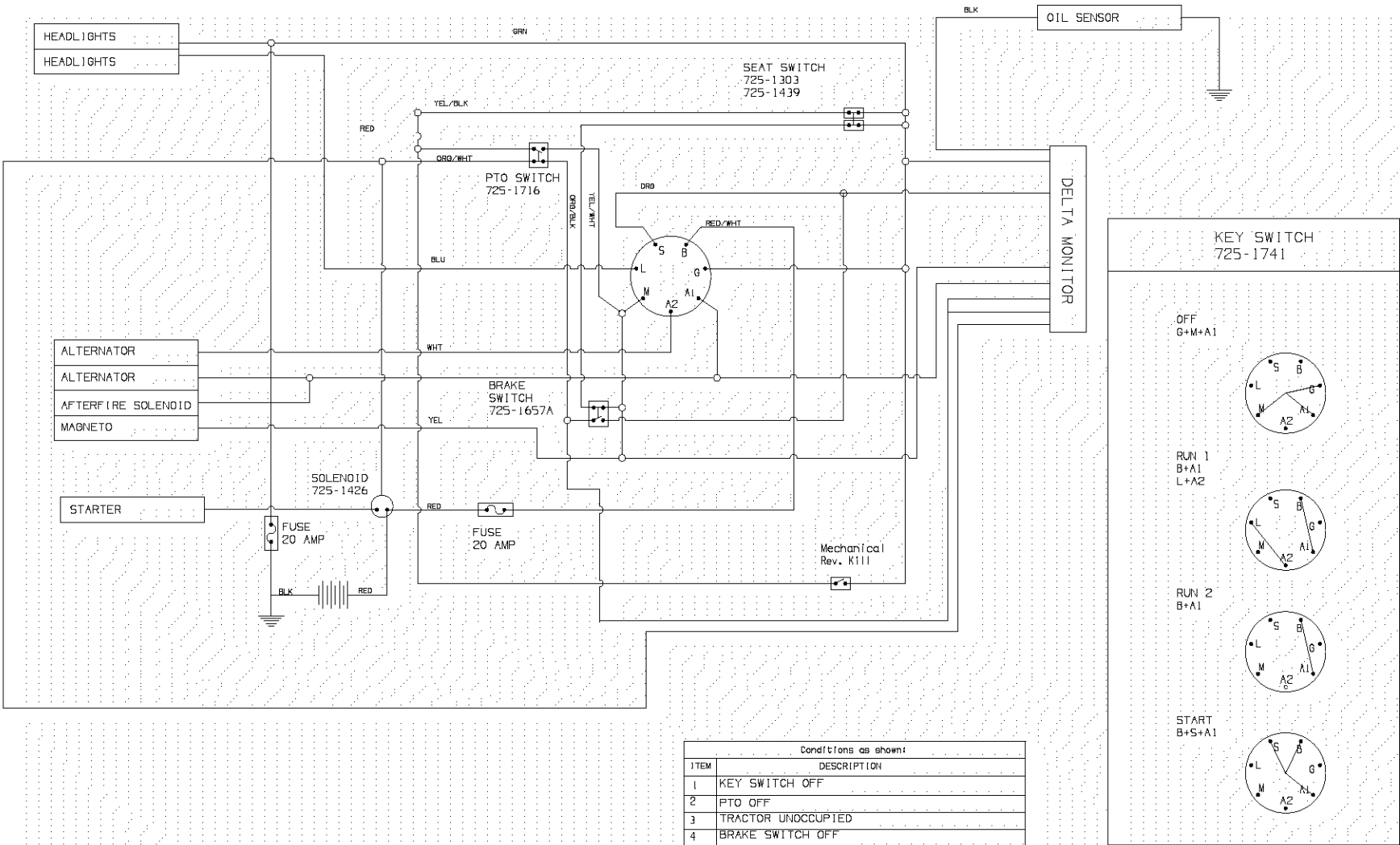

Conditions as shown:	
ITEM	DESCRIPTION
1	KEY SWITCH OFF
2	PTO OFF
3	TRACTOR UNOCCUPIED
4	BRAKE SWITCH OFF



777D06727

777S30285



777I20884 (Model LTX-1842) 777I20883 (Model LTX-2146)



777I20776

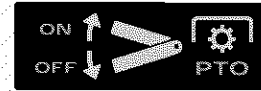

777D06940



777D06942

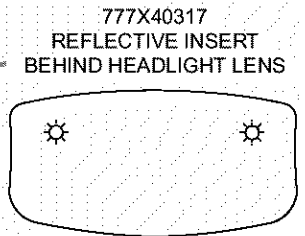
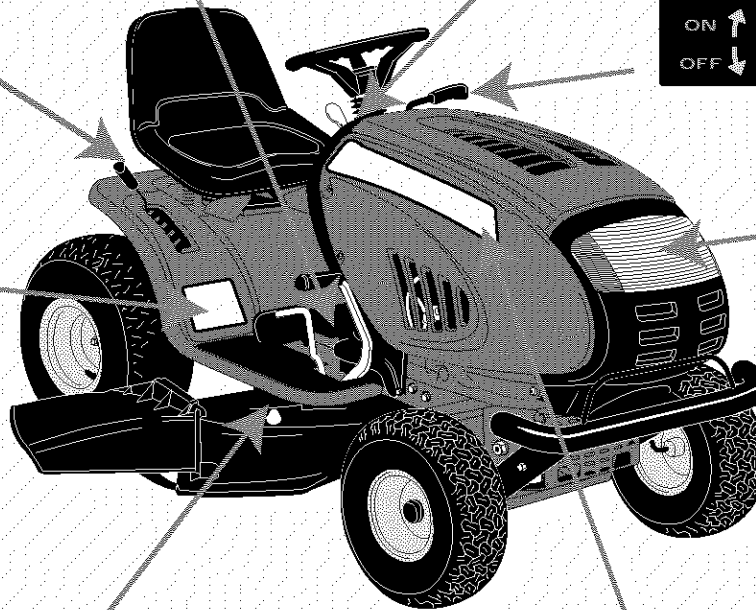

777X40317 REFLECTIVE INSERT BEHIND HEADLIGHT LENS



777D06873

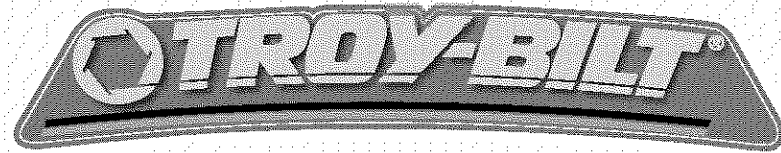

777D06899

Models LTX-1842 & LTX-2146

NOTES

NOTES

MANUFACTURER'S LIMITED WARRANTY FOR:



The limited warranty set forth below is given by Troy-Bilt LLC with respect to new merchandise purchased and used in the United States, its possessions and territories.

Troy-Bilt LLC warrants this product against defects for a period of two (2) years commencing on the date of original purchase and will, at its option, repair or replace, free of charge, any part found to be defective in materials or workmanship. This limited warranty shall only apply if this product has been operated and maintained in accordance with the Operator's Manual furnished with the product, and has not been subject to misuse, abuse, commercial use, neglect, accident, improper maintenance, alteration, vandalism, theft, fire, water, or damage because of other peril or natural disaster. Damage resulting from the installation or use of any accessory or attachment not approved by Troy-Bilt LLC for use with the product(s) covered by this manual will void your warranty as to any resulting damage.

Normal wear parts or components thereof are subject to separate terms as follows: All normal wear parts or component failures will be covered on the product for a period of 90 days regardless of cause. After 90 days, but within the two year period, normal wear part failures will be covered ONLY IF caused by defects in materials or workmanship of OTHER component parts. Normal wear parts and components include, but are not limited to: batteries, belts, blades, blade adapters, grass bags, rider deck wheels, seats, snow thrower skid shoes, shave plates, auger spiral rubber, and tires.

HOW TO OBTAIN SERVICE: Warranty service is available, WITH PROOF OF PURCHASE, through your local authorized service dealer. To locate the dealer in your area, check your Yellow Pages, or contact Troy-Bilt LLC at P.O. Box 361131, Cleveland, Ohio 44136-0019, or call 1-866-840-6483 or 1-330-558-7220, or log on to our Web site at www.troybilt.com.

This limited warranty does not provide coverage in the following cases:

- a. The engine or component parts thereof. These items carry a separate manufacturer's warranty. Refer to applicable manufacturer's warranty for terms and conditions.
- b. Log splitter pumps, valves, and cylinders have a separate one year warranty.
- c. Routine maintenance items such as lubricants, filters, blade sharpening, tune-ups, brake adjustments, clutch adjustments, deck adjustments, and normal deterioration of the exterior finish due to use or exposure.
- d. Troy-Bilt LLC does not extend any warranty for products sold or exported outside of the United States, its possessions and territories, except those sold through Troy-Bilt LLC's authorized channels of export distribution.
- e. Parts that are not genuine Troy-Bilt parts are not covered by this warranty.
- f. Service completed by someone other than an authorized service dealer is not covered by this warranty.
- g. Transportation charges and service calls are not covered.

No implied warranty, including any implied warranty of merchantability of fitness for a particular purpose, applies after the applicable period of express written warranty above as to the parts as identified. No other express warranty, whether written or oral, except as mentioned above, given by any person or entity, including a dealer or retailer, with respect to any product, shall bind Troy-Bilt LLC. During the period of the warranty, the exclusive remedy is repair or replacement of the product as set forth above.

The provisions as set forth in this warranty provide the sole and exclusive remedy arising from the sale. Troy-Bilt LLC shall not be liable for incidental or consequential loss or damage including, without limitation, expenses incurred for substitute or replacement lawn care services or for rental expenses to temporarily replace a warranted product.

Some states do not allow the exclusion or limitation of incidental or consequential damages, or limitations on how long an implied warranty lasts, so the above exclusions or limitations may not apply to you.

In no event shall recovery of any kind be greater than the amount of the purchase price of the product sold. **Alteration of safety features of the product shall void this warranty.** You assume the risk and liability for loss, damage, or injury to you and your property and/or to others and their property arising out of the misuse or inability to use the product.

This limited warranty shall not extend to anyone other than the original purchaser or to the person for whom it was purchased as a gift.

HOW STATE LAW RELATES TO THIS WARRANTY: This limited warranty gives you specific legal rights, and you may also have other rights which vary from state to state.

Troy-Bilt LLC, P.O. BOX 361131 CLEVELAND, OHIO 44136-0019; Phone: 1-866-840-6483, 1-330-558-7220