

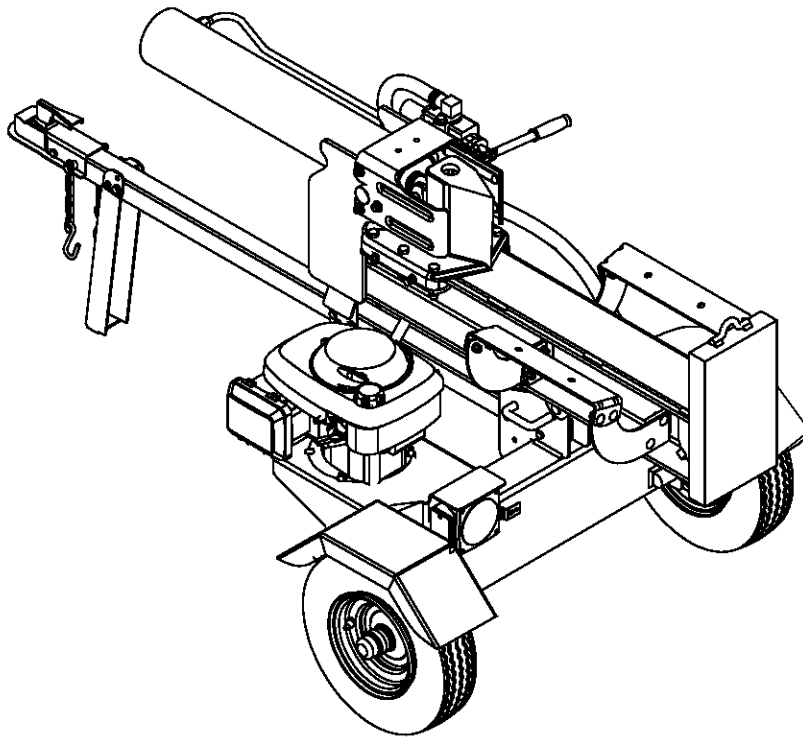

# Operator's Manual



Log Splitter  
Model LS275

**IMPORTANT:** Read safety rules and instructions carefully before operating equipment.

**Warning:** This unit is equipped with an internal combustion engine and should not be used on or near any unimproved forest-covered, brush-covered or grass-covered land unless the engine's exhaust system is equipped with a spark arrester meeting applicable local or state laws (if any). If a spark arrester is used, it should be maintained in effective working order by the operator. In the State of California the above is required by law (Section 4442 of the California Public Resources Code). Other states may have similar laws. Federal laws apply on federal lands. A spark arrester for the muffler is available through your nearest engine authorized service dealer or contact the service department, P.O. Box 361131 Cleveland, Ohio 44136-0019.

**TROY-BILT LLC. P.O. BOX 361131 CLEVELAND, OHIO 44136-0019**

## TABLE OF CONTENTS

Content	Page
Important Safe Operation Practices.....	3
Assembling Your Log Splitter .....	5
Know Your Log Splitter .....	7
Operating Your Log Splitter .....	8
Adjusting Your Log Splitter .....	10
Maintaining Your Log Splitter.....	10
Storing Your Log Splitter.....	12
Troubleshooting.....	12
Parts List.....	14

## FINDING MODEL NUMBER

This Operator's Manual is an important part of your new log splitter. It will help you assemble, prepare and maintain the unit for best performance. Please read and understand what it says.



**Before you start assembling your new equipment**, please locate the model plate on the equipment and copy the information from it in the space provided below. The information on the model plate is very important if you need help from our Customer Support Department or an authorized dealer.

You can locate the model number by standing behind the unit and looking down at the hydraulic tank. A sample model plate is explained below. For future reference, please copy the model number and the serial number of the equipment in the space below.

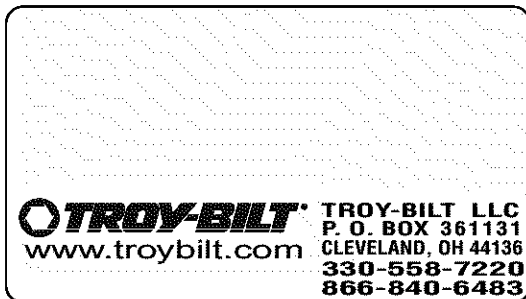

Copy the model number here: \_\_\_\_\_

Copy the serial number here: \_\_\_\_\_

## ENGINE INFORMATION

The engine manufacturer is responsible for all engine-related issues with regards to performance, power-rating, specifications, warranty and service. Please refer to the engine manufacturer's Owner's/Operator's Manual packed separately with your unit for more information.

## CALLING CUSTOMER SUPPORT

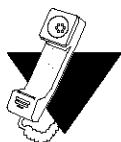

If you have difficulty assembling this product or have any questions regarding the controls, operation or maintenance of this unit, please call **1-866-840-6483** or **1-330-558-7220** to reach a Customer Support representative. Please have your unit's model number and serial number ready when you call. See previous section to locate this information. You will be asked to enter the serial number in order to process your call.

For more details about your unit, visit our website at [www.troybilt.com](http://www.troybilt.com)

---

## SECTION 1: IMPORTANT SAFE OPERATION PRACTICES



**WARNING:** This symbol points out important safety instructions which, if not followed, could endanger the personal safety and/or property of yourself and others. Read and follow all instructions in this manual before attempting to operate this machine. Failure to comply with these instructions may result in personal injury. When you see this symbol - **heed its warning.**

**WARNING:** Engine exhaust, some of its constituents, and certain vehicle components contain or emit chemicals known to the State of California to cause cancer, birth defects or other reproductive harm.

**DANGER:** This machine was built to be operated according to the rules for safe operation in this manual. As with any type of power equipment, carelessness or error on the part of the operator can result in serious injury. This machine is capable of amputating hands and feet and throwing objects. Failure to observe the following safety instructions could result in serious injury or death.

### General Practices

1. Read, understand, and follow all instructions on the machine and in the manual(s) before attempting to assemble and operate. Keep this manual in a safe place for future and regular reference and for ordering replacement parts.
2. Be familiar with all controls and proper operation. Know how to stop the machine and disengage them quickly.
3. Never allow children under 16 years to operate this machine. Children, 16 years and over, should read and understand instructions and safety rules in this manual and should be trained and supervised by a parent.
4. Never allow adults to operate this machine without proper instruction.
5. Many accidents occur when more than one person operates the machine. If a helper is assisting in loading logs, never activate the control until the helper is a minimum of 10 feet from the machine.
6. Keep bystanders, helpers, pets, and children at least 20 feet from the machine while it is in operation.
7. Never allow anyone to ride on this machine.
8. Never transport cargo on this machine.
9. Hydraulic log splitters develop high fluid pressures during operation. Fluid escaping through a pin hole opening can penetrate your skin and cause blood poisoning, gangrene, or death. Give attention to the following instructions at all times:
  - a. Do not check for leaks with your hand.
  - b. Do not operate machine with frayed, kinked, cracked, or damaged hoses, fitting, or tubing.
  - c. Stop the engine and relieve hydraulic system pressure before changing or adjusting fittings, hoses, tubing, or other system components.
  - d. Do not adjust the pressure settings of the pump or valve.
5. Leaks can be detected by passing cardboard or wood, while wearing protective gloves and safety glasses, over the suspected area. Look for discoloration of cardboard or wood.
6. If injured by escaping fluid, see a doctor immediately. Serious infection or reaction can develop if proper medical treatment is not administered immediately.
7. Keep the operator zone and adjacent area clear for safe, secure footing.
8. If your machine is equipped with an internal combustion engine and it is intended for use near any unimproved forest, brush, or grass covered land, the engine exhaust should be equipped with a spark arrester. Make sure you comply with applicable local, state, and federal codes. Take appropriate firefighting equipment with you.
9. This machine should be used for splitting wood only, do not use it for any other purpose.
10. Follow the instructions in the manual(s) provided with any attachment(s) for this machine.

### Preparation

1. Always wear safety shoes or heavy boots.
2. Always wear safety glasses or safety goggles during operating this machine.
3. Never wear jewelry or loose clothing that might become entangled in moving or rotating parts of the machine.
4. Make sure machine is on level surface before operating.
5. Always block machine to prevent unintended movement, and lock in either horizontal or vertical position.
6. Always operate this machine from the operator zone(s) specified in the manual.
7. Logs should be cut with square ends prior to splitting.
8. Use log splitter in daylight or under good artificial light.
9. To avoid personal injury or property damage use extreme care in handling gasoline. Gasoline is extremely flammable and the vapors are explosive. Serious personal injury can occur when gasoline is spilled on yourself or your clothes which can ignite. Wash your skin and change immediately.
  - a. Use only an approved gasoline container.
  - b. Extinguish all cigarettes, cigars, pipes, and other sources of ignition.
  - c. Never fuel machine indoors.
  - d. Never remove gas cap or add fuel while the engine is hot or running.
  - e. Allow engine to cool at least two minutes before refueling.
  - f. Never overfill the fuel tank. Fill tank to no more than 1/2 inch below bottom of filler neck to provide space for fuel expansion.
  - g. Replace gasoline cap and tighten securely.

- h. If gasoline is spilled, wipe it off the engine and equipment. move machine to another area. Wait 5 minutes before starting the engine.
- i. Never store the machine or fuel container inside where there is an open flame, spark or pilot light as on a water heater, space heater, furnace, clothes dryer or other gas appliances.
- j. Allow machine to cool 5 minutes before storing.

## Operation

1. Before starting this machine, review the "Safety Instructions". Failure to follow these rules may result in serious injury to the operator or bystanders.
2. Never leave this machine unattended with the engine running.
3. Do not operate machine while under the influence of alcohol, drugs, or medication.
4. Never allow anyone to operate this machine without proper instruction.
5. Always operate this machine with all safety equipment in place and working. Make sure all controls are properly adjusted for safe operation.
6. Do not change the engine governor settings or overspeed the engine. The governor controls the maximum safe operating speed of the engine.
7. When loading a log, always place your hands on the sides of the log, not on the ends, and never use your foot to help stabilize a log. Failure to do so, may result in crushed or amputated fingers, toes, hand, or foot.
8. Use only your hand to operate the controls.
9. Never attempt to split more than one log at a time unless the ram has fully extended and a second log is needed to complete the separation of the first log.
10. For logs which are not cut square, the least square end and the longest portion of the log should be placed toward the beam and wedge, and the square end placed toward the end plate.
11. When splitting in the vertical position, stabilize the log before moving the control. Split as follows:
  - a. Place log on the end plate and turn until it leans against the beam and is stable.
  - b. When splitting extra large or uneven logs, the log must be stabilized with wooden shims or split wood between the log and end plate or ground.
12. Always keep fingers away from any cracks that open in the log while splitting. They can quickly close and pinch or amputate your fingers.
13. Keep your work area clean. Immediately remove split wood around the machine so you do not stumble over it.
14. Never move this machine while the engine is running.
15. This machine should not be towed on any street, highway or public road without checking the existing federal, state, or local vehicle requirements. Any licensing or modifications such as taillights, etc., needed to comply, is the sole responsibility of the purchaser. If a "Statement of Origin" is required in your state, see your local dealer.
16. Do not tow machine faster than 45mph.
17. See Transporting the Log Splitter section in this manual for proper towing instructions once all federal, local, or state requirements are met.

## Maintenance and Storage

1. Stop the engine, disconnect the spark plug and ground it against the engine before cleaning, or inspecting the machine.
2. Stop the engine and relieve hydraulic system pressure before repairing or adjusting fittings, hoses, tubing, or other system components.
3. To prevent fires, clean debris and chaff from the engine and muffler areas. If the engine is equipped with a spark arrester muffler, clean and inspect it regularly according to manufacturers instructions. Replace if damaged.
4. Periodically check that all nuts and bolts, hose clamps, and hydraulic fittings are tight to be sure equipment is in safe working condition.
5. Check all safety guards and shields to be sure they are in the proper position. Never operate with safety guards, shields, or other protective features removed.
6. The pressure relief valve is preset at the factory. Do not adjust the valve.
7. Never attempt to move this machine over hilly or uneven terrain without a tow vehicle or adequate help.
8. For your safety, replace all damaged or worn parts immediately with original equipment manufacturer's (O.E.M.) parts only. "Use of parts which do not meet the original equipment specifications may lead to improper performance and compromise safety!"
9. Do not alter this machine in any manner, alterations such as attaching a rope or extension to the control lever, or adding to the width or height of the wedge may result in personal injury.

## Your Responsibility

Restrict the use of this power machine to persons who read, understand and follow the warnings and instructions in this manual and on the machine. Some of the safety labels are reproduced here. Always follow directions on safety labels found on your equipment.

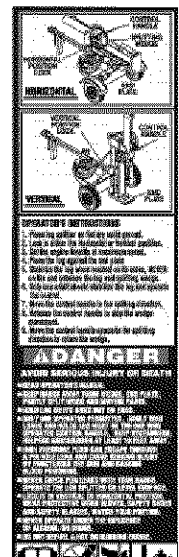

## SECTION 2: ASSEMBLING YOUR LOG SPLITTER

### Unpacking from Crate

- Pry top, sides, and ends off the crate. Set panels aside to avoid tire puncture or personal injury.
- Remove and discard plastic bag that covers unit.
- Remove any loose parts if included with unit (i.e., operator's manual, etc.)
- Cut and remove straps which secure parts to bottom of crate. Unbolt any remaining parts which may be bolted to the bottom of the crate.



**WARNING:** Use extreme caution unpacking this machine. Some components are very heavy and will require additional people or mechanical handling equipment.

### Loose Parts In Carton

- Tongue assembly
- Bottle of engine oil
- Tail light kit

### Before Assembly

- Disconnect the spark plug wire and ground against the engine to prevent unintended starting.

**NOTE:** Reference to right or left hand side of the log splitter is observed from the operating position.

### Assembling the Tongue

#### Attaching the Jack Stand

- The jack stand is shipped in the transport position. Remove the spring clip and clevis pin and pivot the jack stand towards the ground to the operating position.
- Secure the jack stand in position with the clevis pin and spring clip. See Figure 1.

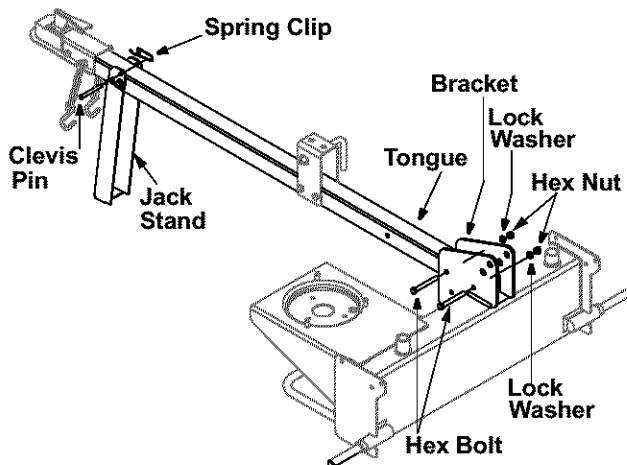

Figure 1

#### Attaching the Tongue

- With the log splitter still standing upright, remove two hex bolts, lock washers, and hex nuts from the end of the tongue. See Figure 1.
- Align the holes in the tongue with the holes in the tank bracket and secure with hardware just removed. See Figure 1.

**NOTE:** High pressure hose must be above the tongue assembly.

### Connecting Cylinder to Beam

- The log splitter is shipped with the beam in the vertical position. Pull out the vertical lock beam, rotate it back, and pivot the beam to the horizontal position until it locks. See Figure 2.

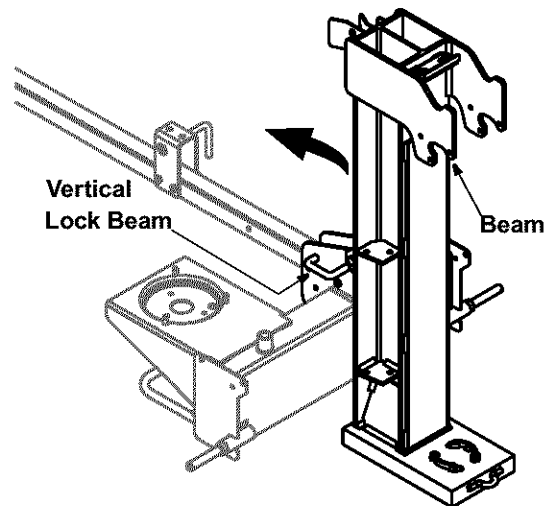

Figure 2

- Disconnect the dislodger from the beam weld bracket by removing the six hex screws and flat washers. See Figure 3.

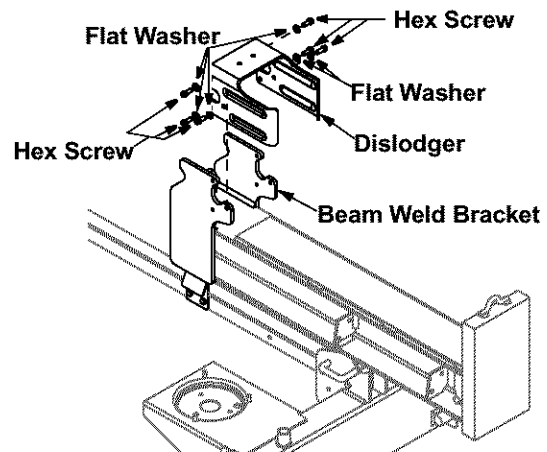

Figure 3

- Disconnect the log cradle from the beam on the side of the control valve. See Figure 4.

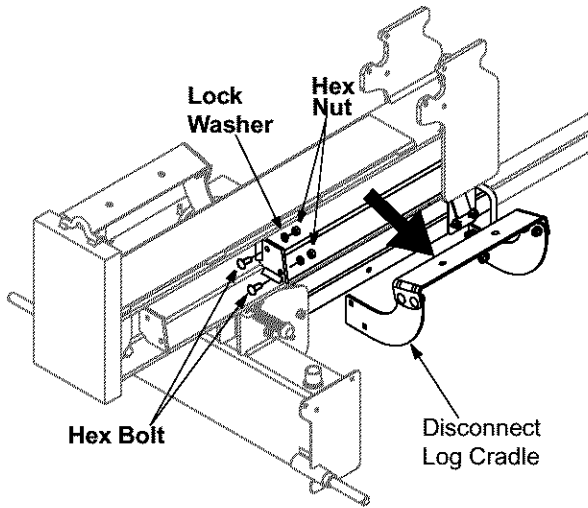

Figure 4

- Lift and slide the cylinder up to the top of beam and into the weld brackets.
- Attach the dislodger over the wedge assembly and secure with hardware, previously removed, to the weld brackets. See Figure 5.

**NOTE:** Once the six hex screws are tightened, there may be a slight gap between the dislodger and the weld brackets. This gap is normal.

- Reattach the log cradle to the side of the beam with the control valve, aligning the ends of the cradle with the beam flanges. See Figure 5.
- Roll log splitter off the bottom crate.

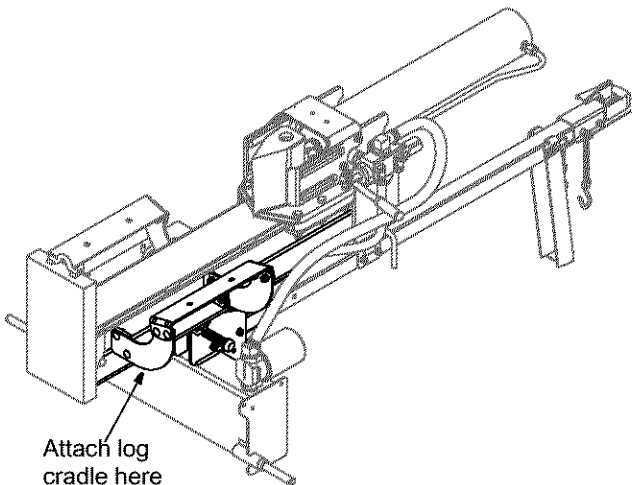

Figure 5

## Preparing the Log Splitter

- Lubricate the beam area (where the splitting wedge will slide) with engine oil; do not use grease.
- Remove vented reservoir dipstick, which is located in front of the engine on top of the reservoir tank. See Figure 6.
- Fill the reservoir tank with Dexron III automatic transmission fluid or 10W AW hydraulic fluid.

**NOTE:** The reservoir tank has a capacity of 3.5 gallons.

- Check fluid level using the dipstick. See Figure 6.
- Do not overfill. Replace vented dipstick securely, tightening it until the top of the threads are flush with top of the pipe.

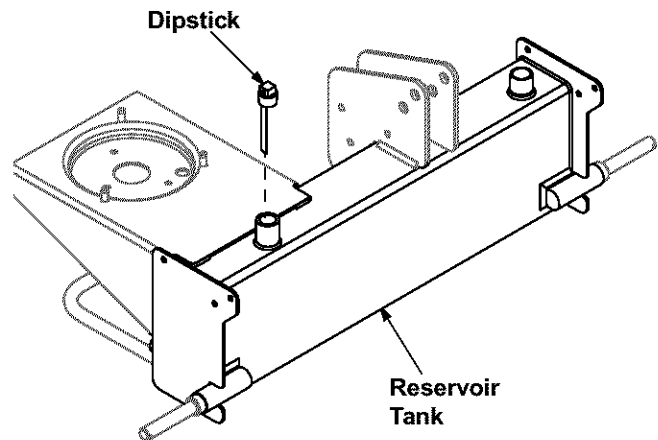

Figure 6

- Make sure the spark plug wire is disconnected. Then prime the pump by pulling the recoil starter as far as it will go. Repeat approximately 10 times.
- Reconnect the spark plug wire and start engine following instructions in the OPERATION section.
- Use control handle to engage the wedge to the farthest extended position. Then retract the wedge.
- Refill tank as specified on the dipstick.

**NOTE:** Failure to refill the tank will void unit's warranty.

- Extend and retract the wedge 12 complete cycles to remove trapped air in the system (the system is "self-bleeding").
- Refill reservoir within range marked on the dipstick.



**WARNING:** Much of the original fluid has been drawn into the cylinder and hoses. Make certain to refill the reservoir to prevent damage to the hydraulic pump.

**NOTE:** Some fluid may overflow from the vent plug as the system builds heat and the fluid expands and seeks a balanced level.

- Attach taillights as instructed in the taillight kit manual included with your log splitter.

## SECTION 3: KNOW YOUR LOG SPLITTER

Compare the illustration in Figure 7 below with the controls on your log splitter, and get familiar with its features before starting to operate. Know how to stop the machine quickly in the event of an emergency.

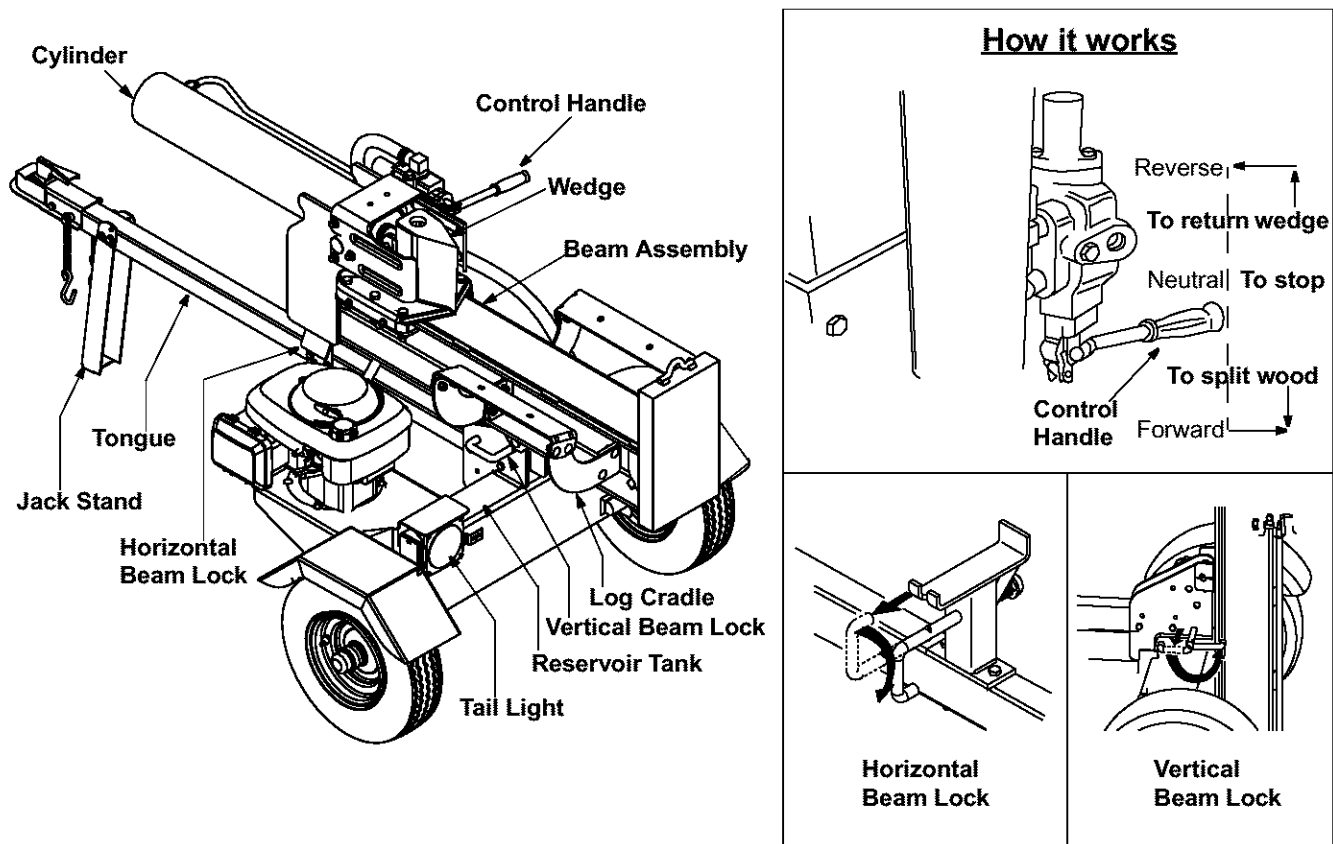

Figure 7

### Control Handle

The control handle has three positions. See Figure 7.

- Move control handle FORWARD or DOWN to move wedge down to split wood.

**NOTE:** Control handle will return to neutral position as soon as handle is released.

- Release the control handle to stop the wedge movement.
- Move control handle BACK or UP to return the wedge toward the cylinder. The control handle will lock in the disengaged position. It will return to neutral automatically when the return stroke is complete.

### Beam Locks

These two locks, as their name suggests, are used to secure the beam in the horizontal or the vertical position. The vertical beam lock is located next to the oil filter. The horizontal beam lock is located on the beam support latch bracket. See Figure 7.

### Engine Controls

See the accompanying engine manual for the location and function of the controls on the engine.

### Stopping Engine

- Move throttle control lever to STOP or OFF position.
- Turn off the fuel valve.
- Disconnect spark plug wire and ground against the engine to prevent unintended starting.

**IMPORTANT:** This unit is shipped without gasoline or oil in the engine. Be certain to service engine with gasoline and oil as instructed in the accompanying engine manual before operating your machine.

## SECTION 4: OPERATING YOUR LOG SPLITTER



**WARNING:** Read, understand, and follow all instructions and warnings on the machine and in this manual before operating.

**WARNING:** Wear leather work gloves, safety shoes, ear protection, and safety glasses when operating log splitter. Ensure safe footing.

### Gas and Oil Fill-Up

- Service the engine with gasoline and oil as instructed in the engine manual packed with your log splitter. Read instructions carefully.



**WARNING:** Use extreme care when handling gasoline. Gasoline is extremely flammable and the vapors are explosive. Never fuel machine indoors or while the engine is hot or running.

**NOTE:** Gasoline can be added to the engine when the log splitter is in either the horizontal or vertical position. However, there are less obstructions when the unit is in the vertical position.

### Starting Engine

- Attach spark plug wire to spark plug. Make certain the metal cap on the end of the spark plug wire is fastened securely over metal tip of the spark plug.
- Turn the fuel valve to the ON position.
- Move choke lever to CHOKE position.
- Turn the throttle control lever to the FAST position.
- Grasp starter handle and pull rope out slowly until engine reaches start of compression cycle (rope will pull slightly harder at this point).
- Pull rope with a rapid, full arm stroke. Keep firm grip on starter handle. Let rope rewind slowly. Repeat until engine cranks.
- After engine starts, move choke lever to OFF position. Place throttle lever to the speed desired. For best performance, the engine is designed to be operated at the FAST throttle position.
- If weather is cold, run wedge up or down beam 6 to 8 times to circulate the hydraulic fluid.



**WARNING:** When starting a warm engine, the muffler and surrounding areas are hot and can cause a burn. Do not touch.

### Before Each Use

- Remove the dipstick and check hydraulic fluid level. Refill if necessary.
- Check engine oil level. Refill if necessary.

- Fill up gasoline if necessary.
- Lubricate with engine oil the beam area where splitting wedge will slide. Do not use grease to lubricate. Make sure to lubricate both the front and the back of the beam face.
- Attach spark plug wire to the spark plug.

### Using the Log Splitter

- Place the log splitter on level, dry ground.
- Place the beam in either the horizontal or vertical position and lock in place with the appropriate locking rod.
- Block the front and back of both wheels.
- Place the log against the end plate and only split wood in the direction of the grain.
- To stabilize the log, place your hand only on sides of log. **Never place hand** on the end between the log and the splitting wedge.
- Only one adult should stabilize the log and operate the control handle, so the operator has full control over the log and the splitting wedge.

#### Control Handle

1. Move control handle FORWARD or DOWN to split wood.
2. Release the control handle to stop the wedge movement.
3. Move control handle BACK or UP to return the wedge.

#### Vertical Position

- Pull the horizontal beam lock out to release the beam and pivot the beam to the vertical position.
- To lock the beam in the vertical position, pull out on the vertical beam lock and rotate it to secure the beam. See Figure 7.
- Stand in front of the unit to operate the control handle and to stabilize the log. See Figure 8A.

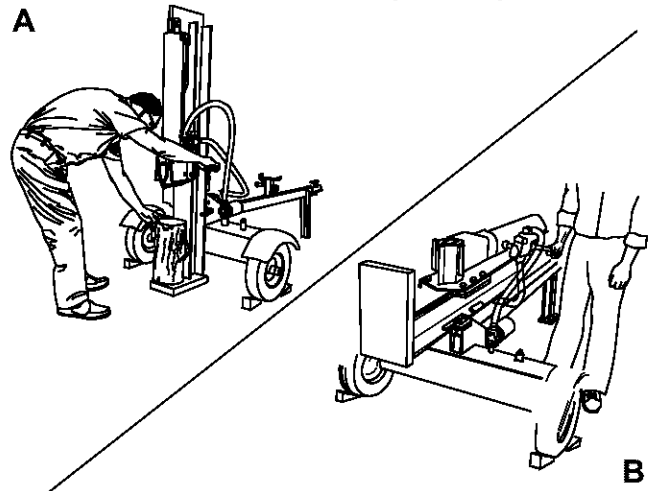

Figure 8



## Horizontal Position

- Pull the vertical beam lock out and rotate it down. See Figure 7. Pivot beam to the horizontal position. The beam will lock automatically in horizontal position.
- Stand behind the reservoir tank to operate control handle and to stabilize the log. See Figure 8B.

## Operating Tips

### Always:

1. Use clean fluid and check fluid level regularly.
2. Use Dexron III Automatic Transmission Fluid or 10W AW hydraulic fluid.
3. Use a filter (clean or replace regularly)
4. Use a breather cap on fluid reservoir.
5. Make sure pump is mounted and aligned properly.
6. Use a flexible "spider" type coupling between engine and pump drive shafts.
7. Keep hoses clear and unblocked.
8. Bleed air out of hoses before operating.
9. Flush and clean hydraulic system before restarting after servicing.
10. Use "pipe dope" on all hydraulic fittings.
11. Allow time for warm-up before splitting wood.
12. Prime the pump before initial start-up by turning over the engine with spark plug disconnected.
13. Split wood along the grain (lengthwise) only.

### Never:

1. Use when fluid is below 20° F or above 150° F.
2. Use a solid engine /pump coupling.
3. Operate through relief valve for long.
4. Attempt to adjust unloading or relief valve settings without pressure gauges.
5. Operate with air in hydraulic system.
6. Use teflon tape on hydraulic fittings.
7. Attempt to cut wood across the grain.

## Raising and Lowering Beam

- Use control handle to run wedge up and down beam 6 to 8 times to circulate the hydraulic fluid, which will warm and thin the fluid.
- Place log splitter on a firm, level surface.
- **To raise the beam for vertical operation:** Pull out the vertical beam lock on the tongue.
- Pivot beam lock down to release the beam.
- Move the beam to the vertical position. Secure it with the beam lock on the reservoir tank assembly.
- **To lower the beam:** Pull out the horizontal beam lock on the reservoir tank.



**WARNING:** Always use the log splitter in the vertical position when **splitting heavy logs**.

- Pivot beam lock down to release the beam. Carefully pull back on beam and lower it to the horizontal position. The horizontal beam lock will lock automatically. See Figure 7.

## Transporting the Log Splitter

**IMPORTANT:** Always turn fuel valve to OFF position before transporting the log splitter.

- Lower the beam to its horizontal position. Make certain the beam is locked securely with the horizontal beam lock.
- Remove spring clip and clevis pin from jack stand.
- Support the tongue and pivot the jack stand up against the tongue. See Figure 9.

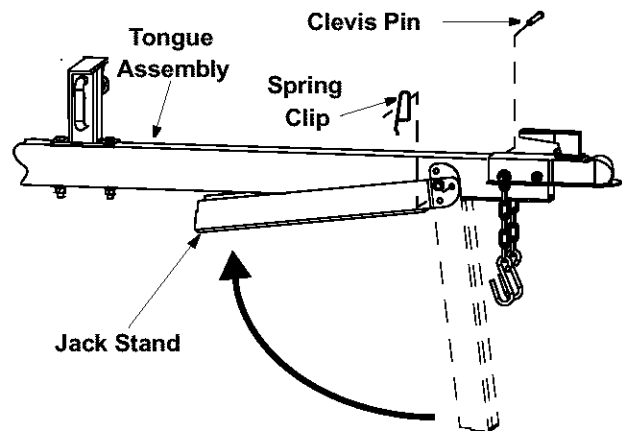

Figure 9

- Secure with the spring clip and clevis pin previously removed. See Figure 9.
- Attach coupler hitch to a class I or higher 1-7/8" ball on a towing vehicle; latch securely.
  - a. **If coupler hitch does not fit on ball:** Turn adjustment nut one turn counter-clockwise.
  - b. **If coupler hitch is too loose on ball:** Turn adjustment nut one turn clockwise.
- Connect the safety chains to the towing vehicle.
- Plug in the tail lights to the tail light connector on the tow vehicle.



**WARNING:** Do not tow faster than 45mph and check local, state, and federal requirements before towing on any public road.

**NOTE:** Use caution when backing up. It is recommended to use a spotter outside the vehicle.

---

## SECTION 5: ADJUSTING YOUR LOG SPLITTER



**WARNING:** Do not at any time make any adjustments without first stopping engine, disconnecting spark plug wire, and grounding it against the engine.

### Wedge Assembly Adjustment

As normal wear occurs and there is excessive “play” between the wedge and beam, adjust the bolts on the side of the wedge assembly to eliminate excess space between the wedge and the beam. See Figure 10.

- Loosen the jam nuts on the two adjustment bolts on the side of the wedge. Turn the adjustment bolts in until snug and then back them off slowly until the wedge assembly will slide on the beam.
- Tighten the jam nuts securely against the side of the wedge to hold the adjustment bolts in this position.

### Gib Adjustment

Periodically remove and replace the “gibs” (spacers) between the wedge assembly and the back plate. See Figure 10.

**NOTE:** The gibs may be rotated and/or turned over for even wear.

- Loosen the lock nuts under the each back plate and slide the gibs out.
- Turn or replace the gibs.
- Reassemble the back plate and secure with the lock washers and lock nuts.
- Readjust the bolts on the side of the wedge assembly.

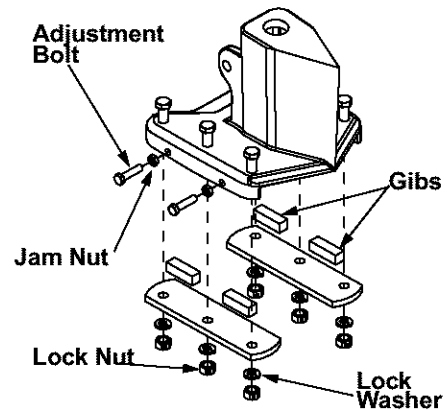

Figure 10

---

## SECTION 6: MAINTAINING YOUR LOG SPLITTER



**WARNING:** Before cleaning, lubricating, repairing, or inspecting, disengage the control lever and stop engine. Disconnect the spark plug wire and ground it against the engine to prevent unintended starting.

### Conditions that will void warranty

1. Failure to maintain proper fluid level in reservoir
2. Changing the relief valve setting or pressure adjustment of control valve without proper knowledge and instruction from the factory



**WARNING:** Higher pressure could cause the hoses to burst, cylinder to rupture, and intense fluid to be released, which could result in serious personal injury.

3. Disassembling the pump
4. Use of incorrect hydraulic fluid
5. Allowing the flexible pump coupler to deteriorate without proper and regular inspection
6. Lack of lubrication or improper lubrication of the beam or unit
7. Improper adjustment of splitting wedge

8. Excessive heating of the hydraulic system
9. Attempting to start unit in temperatures under 20°F without pre-heating fluid in reservoir
10. Unattended leaks in hydraulic system

### Hydraulic Fluid

- Check the hydraulic fluid level in the log splitter reservoir tank before each use.
- Maintain fluid level within the range specified on the dipstick at all times.
- Change the hydraulic fluid in the reservoir every 100 hours of operation.
- Disconnect the suction hose from the bottom of the reservoir tank and drain the fluid into a suitable container. Refill using only Dexron III automatic transmission fluid or 10W AW hydraulic fluid.

**NOTE:** Please dispose of used hydraulic fluid and engine oil at approved recycling centers only.

- Since contaminants in fluid may damage the hydraulic components, you will have to drain the fluid and flush the reservoir tank and hoses with kerosene whenever any repair work is performed on the tank, hydraulic pump or valve. For this job, contact your nearest service dealer.

## Hydraulic Filter

- Change the hydraulic filter every 50 hours of operation. Use only a 10 micron hydraulic filter. Order part number 723-0405.

## Beam and Splitting Wedge

- Lubricate both sides of the beam (where it comes into contact with the splitting wedge), before each use, with engine oil. The wedge plate on the log splitter is designed so the gibs on the side of the wedge plate can be removed and rotated and/or turned over for even wear.
- Make certain to readjust the adjustment bolts so wedge moves freely, but no excess space exists between the wedge plate and the beam.

## Hose Clamps

- Check, before each use, if hose clamps on the suction hose (attached to the side of the pump) are tight. Check the hose clamps on the return hose at least once a season.

## Engine

Refer to the engine manual for all maintenance needs.

## Flexible Pump Coupler

The flexible pump coupler is a nylon "spider" insert, located between the pump and the engine shaft. Over time, the coupler will harden and deteriorate.

Replace the coupler if you detect vibration or noise coming from the area between the engine and the pump. If the coupler fails completely, you will experience a loss of power.

**IMPORTANT:** Never hit the engine shaft in any manner, as a blow will cause permanent damage to the engine.

- Remove three nuts and lock washers that secure the pump to the coupling shield. Two nuts are at the bottom corners and one is in the top center.
- Remove the pump.
- Rotate the engine by slowly pulling starter handle until engine coupling half set screw is visible. Loosen set screw using allen wrench and slide coupling half off engine shaft.
- Loosen set screw on pump coupling half and remove coupling half.

- Slide new engine coupling half onto the engine shaft until the end of the shaft is flush with the inner portion of the coupling half. (There must be space between end of the engine support bracket and coupling half). Tighten set screw.
- Install pump coupling half and key on pump shaft. Rotate coupling half until set screw faces opening in shield. Do not tighten set screw.
- Install nylon "spider" onto engine coupling half.
- Align pump coupling half with nylon "spider" by rotating engine using starter handle. Slide coupling half into place while guiding three mounting bolts through holes in pump support bracket.
- Secure with nuts and washers removed earlier.
- Set .010" to .060" clearance between the nylon "spider" and the engine coupling half by sliding a matchbook cover between the nylon "spider" and the engine coupling half and moving pump coupling half as needed. Secure pump coupling half with set screw. See Figure 11.

**NOTE:** Make certain proper clearance is obtained before tightening set screw.

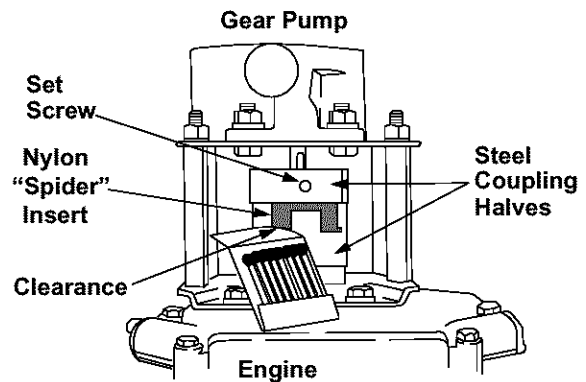

Figure 11

## Tires

See sidewall of tire for recommended pressure. Maximum tire pressure under any circumstances is 30 p.s.i. Maintain equal pressure on all tires.



**WARNING:** Excessive pressure (over 30 p.s.i.) when seating beads may cause tire/rim assembly to burst with force sufficient to cause serious injury.

## SECTION 7: STORING YOUR LOG SPLITTER

Prepare your log splitter for storage at the end of the season or if the log splitter will not be used for 30 days or more.



**WARNING:** Never store machine with fuel in the fuel tank inside of building where fumes may reach an open flame or spark, or where ignition sources are present such as hot water and space heaters, furnaces, clothes dryers, stoves, electric motors, etc.

- Clean the log splitter thoroughly.

**NOTE:** We do not recommend the use of pressure washers or garden hose to clean your unit. They may cause damage to electric components, spindles, pulleys, bearings or the engine. The use of water will result in shortened life and reduce serviceability.

- Wipe unit with an oiled rag to prevent rust, especially on the wedge and the beam.

- Drain fuel tank. Always drain fuel into approved container outdoors, away from open flame. Be sure that engine is cool before draining the fuel. Do not smoke while handling fuel.
- Start the engine and let it run until the fuel lines and carburetor are empty.
- Remove spark plug. Holding a rag over the cylinder hole, pour approximately 1/2 ounce (approximately one tablespoon) of engine oil into cylinder and crank slowly to distribute the oil.
- Replace spark plug.
- Do not store gasoline from one season to another.
- Replace your gasoline can if it starts to rust. Rust and/or dirt in the gasoline will cause problems.
- Store unit in a clean, dry area. Do not store next to corrosive materials, such as fertilizer.

**NOTE:** If storing in an unventilated or metal storage shed, be certain to rustproof the equipment by coating with a light oil or silicone.

## SECTION 8: TROUBLESHOOTING

Problem	Cause	Remedy
Engine fails to start	<ol style="list-style-type: none"> <li>1. Spark plug wire disconnected.</li> <li>2. Fuel tank empty or stale fuel.</li> <li>3. Throttle control lever not in correct starting position.</li> <li>4. Choke not in CHOKE position.</li> <li>5. Engine not primed properly.</li> <li>6. Blocked fuel line.</li> <li>7. Faulty spark plug.</li> </ol>	<ol style="list-style-type: none"> <li>1. Connect wire to spark plug.</li> <li>2. Fill tank with clean, fresh gasoline.</li> <li>3. Move throttle lever to FAST position.</li> <li>4. Move choke to CHOKE position.</li> <li>5. Prime engine.</li> <li>6. Clean fuel line.</li> <li>7. Clean, adjust gap, or replace.</li> </ol>
Engine runs erratic	<ol style="list-style-type: none"> <li>1. Spark plug wire loose.</li> <li>2. Unit running on CHOKE.</li> <li>3. Blocked fuel line or stale fuel.</li> <li>4. Water or dirt in fuel system.</li> <li>5. Dirty air cleaner.</li> <li>6. Carburetor out of adjustment.</li> </ol>	<ol style="list-style-type: none"> <li>1. Connect and tighten spark plug wire.</li> <li>2. Move choke lever to OFF position.</li> <li>3. Clean fuel line; fill tank with clean, fresh gasoline</li> <li>4. Drain fuel tank. Refill with fresh fuel.</li> <li>5. Clean or replace air cleaner.</li> <li>6. See authorized service dealer.</li> </ol>
Engine overheats	<ol style="list-style-type: none"> <li>1. Engine oil level low.</li> <li>2. Dirty air cleaner.</li> <li>3. Carburetor not adjusted properly.</li> </ol>	<ol style="list-style-type: none"> <li>1. Fill crankcase with proper oil.</li> <li>2. Clean or replace air cleaner.</li> <li>3. See authorized service dealer.</li> </ol>

**NOTE:** For repairs beyond those listed above, contact your nearest authorized service center.

## Hydraulic Troubleshooting

Problem	Cause	Remedy
Cylinder rod will not move	<ol style="list-style-type: none"> <li>1. Broken drive shaft.</li> <li>2. Shipping plugs left in hydraulic hoses.</li> <li>3. Set screws in coupling not adjusted properly.</li> <li>4. Loose shaft coupling.</li> <li>5. Gear sections damaged.</li> <li>6. Damaged relief valve.</li> <li>7. Hydraulic lines blocked.</li> <li>8. Incorrect oil level.</li> <li>9. Damaged directional valve.</li> <li>10. Blocked directional valve.</li> </ol>	<ol style="list-style-type: none"> <li>1. See authorized service dealer.</li> <li>2. Disconnect hydraulic hoses, remove shipping plugs, reconnect hoses.</li> <li>3. See operator's manual for correct adjustment.</li> <li>4. Correct engine/pump alignment as necessary.</li> <li>5. See authorized service dealer.</li> <li>6. See authorized service dealer.</li> <li>7. Flush and clean hydraulic system.</li> <li>8. Check oil level.</li> <li>9. See authorized service dealer.</li> <li>10. Flush and clean hydraulic system.</li> </ol>
Slow cylinder shaft speed while extending and retracting.	<ol style="list-style-type: none"> <li>1. Gear sections damaged.</li> <li>2. Excessive pump inlet vacuum.</li> <li>3. Slow engine speed.</li> <li>4. Damaged relief valve.</li> <li>5. Incorrect oil level.</li> <li>6. Contaminated oil.</li> <li>7. Directional valve leaking internally.</li> <li>8. Internally damaged cylinder.</li> </ol>	<ol style="list-style-type: none"> <li>1. See authorized service dealer.</li> <li>2. Make certain pump inlet hoses are clear and unblocked-use short, large diameter inlet hoses.</li> <li>3. See authorized service dealer.</li> <li>4. See authorized service dealer.</li> <li>5. Check oil level.</li> <li>6. Drain oil, clean reservoir, and refill.</li> <li>7. See authorized service dealer.</li> <li>8. See authorized service dealer.</li> </ol>
Leaking cylinder	<ol style="list-style-type: none"> <li>1. Broken seals.</li> <li>2. Scored cylinder.</li> </ol>	<ol style="list-style-type: none"> <li>1. See authorized service dealer.</li> <li>2. See authorized service dealer.</li> </ol>
Engine runs but wood will not split or wood splits too slowly	<ol style="list-style-type: none"> <li>1. Small gear section damaged.</li> <li>2. Pump check valve leaking.</li> <li>3. Excessive pump inlet vacuum.</li> <li>4. Incorrect oil level.</li> <li>5. Contaminated oil.</li> <li>6. Directional valve leaking internally.</li> <li>7. Overloaded cylinder.</li> <li>8. Internally damaged cylinder.</li> </ol>	<ol style="list-style-type: none"> <li>1. See authorized service dealer.</li> <li>2. See authorized service dealer.</li> <li>3. Make certain pump inlet hoses are clear and unblocked.</li> <li>4. Check oil level.</li> <li>5. Drain oil, clean reservoir, and refill.</li> <li>6. See authorized service dealer.</li> <li>7. Do not attempt to split wood against the grain.</li> <li>8. See authorized service dealer.</li> </ol>
Engine stalls during splitting	<ol style="list-style-type: none"> <li>1. Low horsepower/weak engine.</li> <li>2. Overloaded cylinder.</li> </ol>	<ol style="list-style-type: none"> <li>1. See authorized service dealer.</li> <li>2. Do not attempt to split wood against the grain or see authorized service dealer.</li> </ol>
Engine will not turn or stalls under low load conditions	<ol style="list-style-type: none"> <li>1. Engine/pump misalignment.</li> <li>2. Frozen or seized pump.</li> <li>3. Low horsepower/weak engine.</li> <li>4. Hydraulic lines blocked.</li> <li>5. Blocked directional valve.</li> </ol>	<ol style="list-style-type: none"> <li>1. Correct alignment as necessary.</li> <li>2. See authorized service dealer.</li> <li>3. See authorized service dealer.</li> <li>4. Flush and clean hydraulic system.</li> <li>5. Flush and clean hydraulic system.</li> </ol>
Leaking pump shaft seal	<ol style="list-style-type: none"> <li>1. Broken drive shaft.</li> <li>2. Engine/pump misalignment.</li> <li>3. Gear sections damaged.</li> <li>4. Poorly positioned shaft seal.</li> <li>5. Plugged oil breather.</li> </ol>	<ol style="list-style-type: none"> <li>1. See authorized service dealer.</li> <li>2. Correct alignment as necessary.</li> <li>3. See authorized service dealer.</li> <li>4. See authorized service dealer.</li> <li>5. Make certain reservoir is properly vented.</li> </ol>

**NOTE:** For repairs beyond those listed here, contact your nearest authorized service center.

# SECTION 9: PARTS LIST FOR MODEL LS275

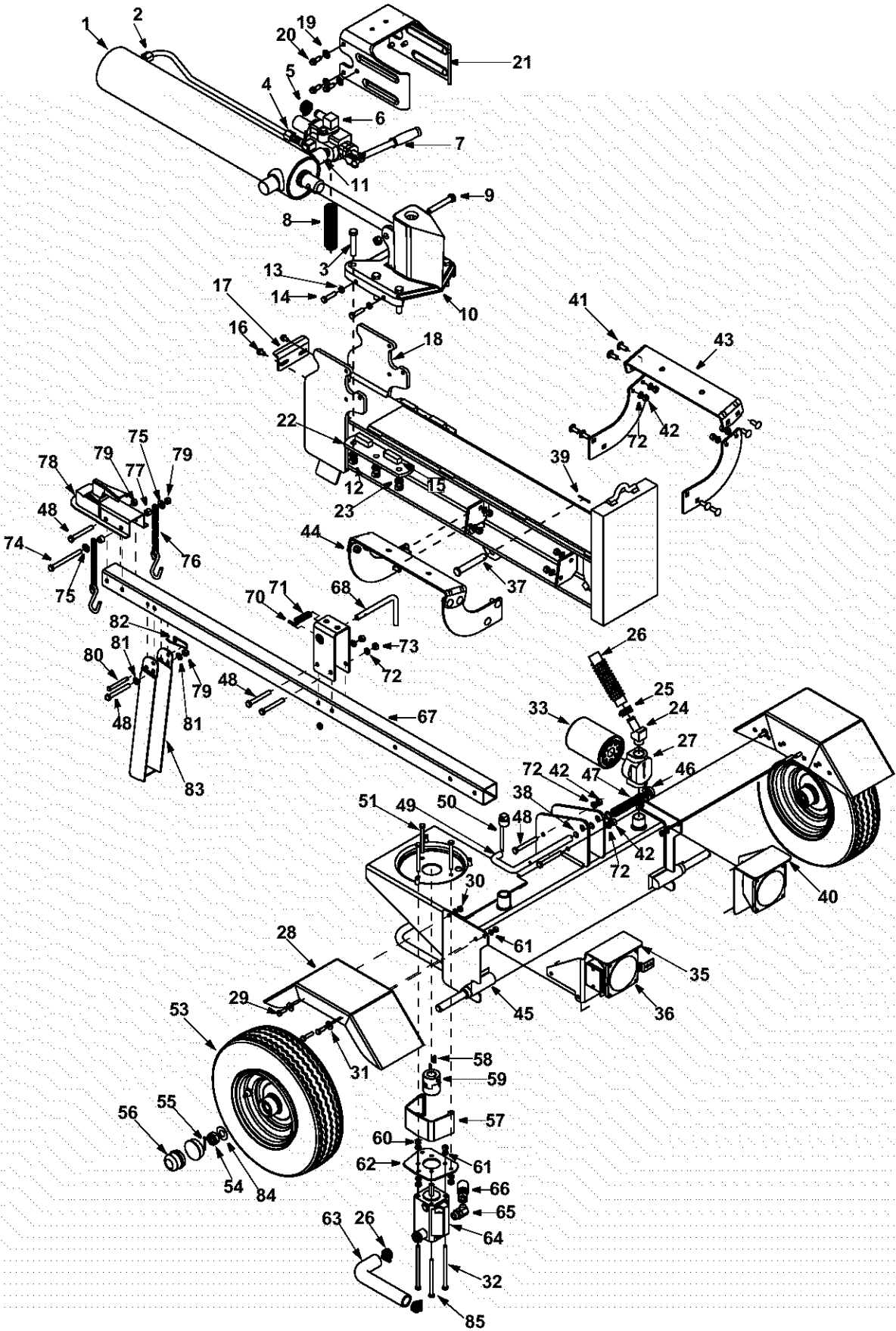

# Model LS275

Ref. No.	Part No.	Part Description	Ref. No.	Part No.	Part Description
1.	718-0769	Hydraulic Cylinder	42.	712-0798	Hex Nut 3/8-16
2.	727-0634	Hydraulic Tube	43.	781-0682	Log Tray
3.	710-1018	Hex Cap Screw 1/2-20 x 2.75	44.	781-0686	Log Tray Bracket
4.	737-0192	90 Degree Solid Adapter	45.	681-0161	Frame Assembly
5.	781-0526	Hose Guard	46.	726-0214	Push Cap
6.	737-0153	Return Elbow	47.	732-0583	Compression Spring
7.	718-0481	Control Valve	48.	710-0521	Hex Bolt 3/8-16 x 3"
8.	781-0538	Hose Guard	49.	781-0690	Lock Rod
9.	710-0515	Hex Cap Screw 1/2-20 x 3.50	50.	737-0348A	Vented Dipstick
10.	719-0550	Wedge Assembly	51.	710-1338	Hex Screw 5/16-24 x 3.25
11.	737-0238	Nipple Pipe 1/2-14	53.	634-0186	Wheel Assembly
12.	712-0239	Lock Nut 1/2-20	54.	712-0359	Slotted Nut 3/4-16
13.	712-0711	Hex Jam Nut 3/8-24	55.	714-0162	Cotter Pin
14.	710-0459A	Hex Cap Screw 3/8-24 x 1.5	56.	734-0873	Hub Cap
15.	781-0351	Adjustable Gib	57.	719-0353	Coupling Shield
16.	710-1260A	LD Screw 5/16-18 x .75	58.	714-0122	Square Key 3/16" x .75
17.	781-1054	Support Bracket	59.	718-0686	Flexible Coupling
18.	681-0162	Beam Assembly	60.	712-0123	Hex Nut 5/16-24
19.	736-0300	Flat Washer .406 ID x .875 OD	61.	736-0119	Lock Washer 5/16" ID
20.	710-0654A	Hex Washer Screw 3/8-16 x 1.0	62.	781-0097	Rear Coupling Support Bracket
21.	781-1048	Dislodger	63.	727-0633	Hose
22.	781-0790	Back Plate	64.	718-0683	Gear Pump (11gpm)
23.	736-0921	Lock Washer 1/2	65.	737-0329	45 Degree Elbow
24.	737-0312	Adapter 3/4-14	66.	727-0502	High Pressure Hydraulic Hose
25.	727-0443	Return Hose 3/4" ID x 44" Lg.	67.	781-0788	Tongue Tube Assembly
26.	726-0132	Hose Clamp 5/8"	68.	747-1261	Latch Rod: Tongue
27.	737-0316	Filter Housing	69.	781-1045	Latch
28.	781-04002	Fender	70.	715-0120	Spiral Pin
29.	710-3038	Hex Screw	71.	732-3127	Compression Spring
30.	712-3010	Hex Nut 5/16-18	72.	736-0169	L-Washer 3/8"
31.	736-0371	Lock Washer 5/16	73.	712-0798	Hex Nut 3/8-16
32.	710-1253	Hex Bolt 5/16-24 x 5.25"	74.	710-0944	Hex Cap Screw 3/8-16 x 4.25
33.	723-0405	Oil Filter	75.	736-0262	Flat Washer .385 ID x .870 OD
34.	710-0376	Hex Cap Screw 5/16-18 x 1.0	76.	713-0433	Chain
35.	681-0164	Light Bracket LH	77.	750-0497	Spacer .375 ID x .625 OD
36.	625-0062	Taillight	78.	727-0311	Coupling Hitch
	725-2058	RH Taillight Assembly	79.	712-0375	Hex Lock Nut 3/8-16
	725-2059	LH Taillight Assembly	80.	711-0813	Clevis Pin
	725-2060	Wiring Harness	81.	736-0185	Flat Washer .375 ID x .738 OD
37.	711-1587	Clevis Pin	82.	732-0194	Spring Pin
38.	736-0116	Flat Washer .635 ID x .93 OD	83.	781-0789	Jack Stand
39.	714-0470	Cotter Pin	84.	736-0351	Flat Washer .760 ID x .500 OD
40.	781-1027	Light Bracket RH	85.	710-3195	Hex Bolt 5/16-18 x 4.5"
41.	710-3097	Carriage Bolt 3/8-16 x 1.0			

# MANUFACTURER'S LIMITED WARRANTY FOR:



The limited warranty set forth below is given by Troy-Bilt LLC with respect to new merchandise purchased and used in the United States, its possessions and territories.

Troy-Bilt LLC warrants this product against defects for a period of two (2) years commencing on the date of original purchase and will, at its option, repair or replace, free of charge, any part found to be defective in materials or workmanship. This limited warranty shall only apply if this product has been operated and maintained in accordance with the Operator's Manual furnished with the product, and has not been subject to misuse, abuse, commercial use, neglect, accident, improper maintenance, alteration, vandalism, theft, fire, water, or damage because of other peril or natural disaster. Damage resulting from the installation or use of any accessory or attachment not approved by Troy-Bilt LLC for use with the product(s) covered by this manual will void your warranty as to any resulting damage.

Normal wear parts or components thereof are subject to separate terms as follows: All normal wear parts or component failures will be covered on the product for a period of 90 days regardless of cause. After 90 days, but within the two year period, normal wear part failures will be covered ONLY IF caused by defects in materials or workmanship of OTHER component parts. Normal wear parts and components include, but are not limited to: batteries, belts, blades, blade adapters, grass bags, rider deck wheels, seats, snow thrower skid shoes, shave plates, auger spiral rubber, and tires.

**HOW TO OBTAIN SERVICE:** Warranty service is available, WITH PROOF OF PURCHASE, through your local authorized service dealer. To locate the dealer in your area, check your Yellow Pages, or contact Troy-Bilt LLC at P.O. Box 361131, Cleveland, Ohio 44136-0019, or call 1-866-840-6483 or 1-330-558-7220, or log on to our Web site at [www.troybilt.com](http://www.troybilt.com).

This limited warranty does not provide coverage in the following cases:

- a. The engine or component parts thereof. These items carry a separate manufacturer's warranty. Refer to applicable manufacturer's warranty for terms and conditions.
- b. Log splitter pumps, valves, and cylinders have a separate one year warranty.
- c. Routine maintenance items such as lubricants, filters, blade sharpening, tune-ups, brake adjustments, clutch adjustments, deck adjustments, and normal deterioration of the exterior finish due to use or exposure.
- d. Troy-Bilt LLC does not extend any warranty for products sold or exported outside of the United States, its possessions and territories, except those sold through Troy-Bilt LLC's authorized channels of export distribution.
- e. Parts that are not genuine Troy-Bilt parts are not covered by this warranty.
- f. Service completed by someone other than an authorized service dealer is not covered by this warranty.
- g. Transportation charges and service calls are not covered.

**No implied warranty, including any implied warranty of merchantability of fitness for a particular purpose, applies after the applicable period of express written warranty above as to the parts as identified. No other express warranty, whether written or oral, except as mentioned above, given by any person or entity, including a dealer or retailer, with respect to any product, shall bind Troy-Bilt LLC. During the period of the warranty, the exclusive remedy is repair or replacement of the product as set forth above.**

**The provisions as set forth in this warranty provide the sole and exclusive remedy arising from the sale. Troy-Bilt LLC shall not be liable for incidental or consequential loss or damage including, without limitation, expenses incurred for substitute or replacement lawn care services or for rental expenses to temporarily replace a warranted product.**

Some states do not allow the exclusion or limitation of incidental or consequential damages, or limitations on how long an implied warranty lasts, so the above exclusions or limitations may not apply to you.

In no event shall recovery of any kind be greater than the amount of the purchase price of the product sold. **Alteration of safety features of the product shall void this warranty.** You assume the risk and liability for loss, damage, or injury to you and your property and/or to others and their property arising out of the misuse or inability to use the product.

This limited warranty shall not extend to anyone other than the original purchaser or to the person for whom it was purchased as a gift.

**HOW STATE LAW RELATES TO THIS WARRANTY:** This limited warranty gives you specific legal rights, and you may also have other rights which vary from state to state.

**Troy-Bilt LLC, P.O. BOX 361131 CLEVELAND, OHIO 44136-0019; Phone: 1-866-840-6483, 1-330-558-7220**