

# OPERATOR'S MANUAL

## Chipper Shredder Model Series 462 thru 465

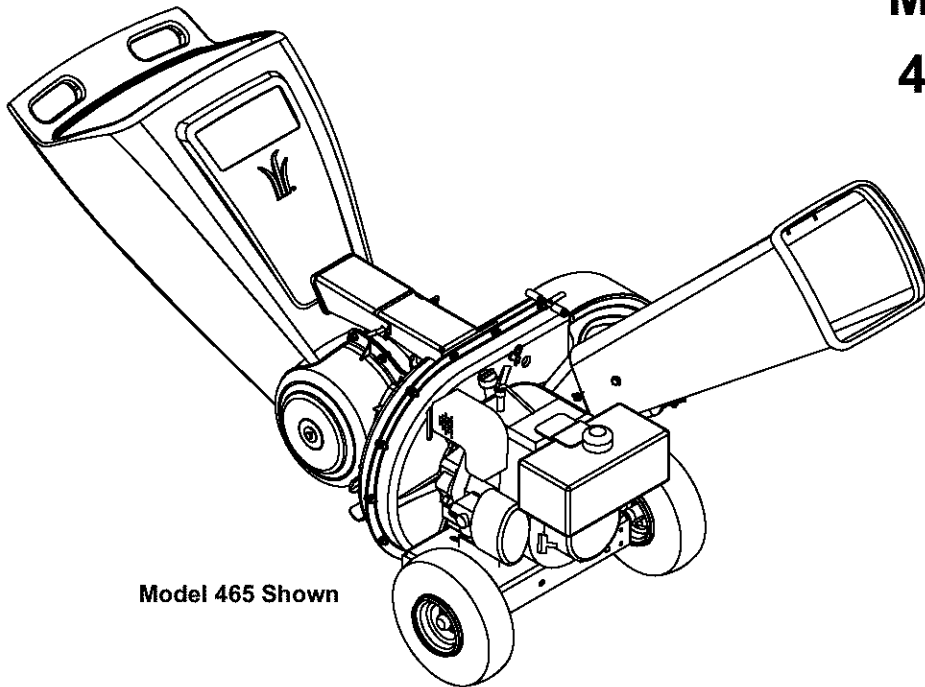

Model 465 Shown

### **IMPORTANT: READ SAFETY RULES AND INSTRUCTIONS CAREFULLY**

**Warning:** This unit is equipped with an internal combustion engine and should not be used on or near any unimproved forest-covered, brush-covered or grass-covered land unless the engine's exhaust system is equipped with a spark arrester meeting applicable local or state laws (if any). If a spark arrester is used, it should be maintained in effective working order by the operator. In the State of California the above is required by law (Section 4442 of the California Public Resources Code). Other states may have similar laws. Federal laws apply on federal lands. A spark arrester for the muffler is available through your nearest engine authorized service dealer or contact the service department, P.O. Box 361131 Cleveland, Ohio 44136-0019.

**MTD LLC, P.O. BOX 361131 CLEVELAND, OHIO 44136-0019**

PRINTED IN U.S.A.

FORM NO. 770-10048F

5/2003

# TABLE OF CONTENTS

Content	Page
Important Safe Operation Practices.....	3
Assembling Your Chipper Shredder.....	5
Know Your Chipper Shredder .....	7
Operating Your Chipper Shredder .....	8
Maintaining Your Chipper Shredder .....	9
Troubleshooting .....	12
Parts List.....	13

## FINDING MODEL NUMBER

This Operator's Manual is an important part of your new chipper shredder. It will help you assemble, prepare and maintain the unit for best performance. Please read and understand what it says.



**Before you start assembling your new equipment**, please locate the model plate on the equipment and copy the information from it in the space provided below. The information on the model plate is very important if you need help from our Customer Support Department or an authorized dealer.

- You can locate the model number by standing behind the unit and looking down at the frame below the engine. A sample model plate is explained below. For future reference, please copy the model number and the serial number of the equipment in the space below.



Copy the model number here: \_\_\_\_\_

Copy the serial number here: \_\_\_\_\_

## ENGINE INFORMATION

The engine manufacturer is responsible for all engine-related issues with regards to performance, power-rating, specifications, warranty and service. Please refer to the engine manufacturer's Owner's/Operator's Manual packed separately with your unit for more information.

## CALLING CUSTOMER SUPPORT

**Please do NOT return the unit to the retailer from which it was purchased, without first contacting Customer Support.**

Should you have difficulty assembling this product or have any questions regarding the controls, operation or maintenance of this unit, please call the Customer Support Department.



Call **1- (330) 220-4MTD (4683)** or **1- (800)-800-7310** to reach a Customer Support representative. Please have your unit's model number and serial number ready when you call. See previous section to locate this information. You will be asked to enter the serial number in order to process your call.

---

## SECTION 1: IMPORTANT SAFE OPERATION PRACTICES



**WARNING:** This symbol points out important safety instructions which, if not followed, could endanger the personal safety and/or property of yourself and others. Read and follow all instructions in this manual before attempting to operate this machine. Failure to comply with these instructions may result in personal injury. When you see this symbol - **heed its warning.**

**WARNING:** The Engine Exhaust from this product contains chemicals known to the State of California to cause cancer, birth defects or other reproductive harm.

**DANGER:** This machine was built to be operated according to the rules for safe operation in this manual. As with any type of power equipment, carelessness or error on the part of the operator can result in serious injury. This machine is capable of amputating hands and feet and throwing objects. Failure to observe the following safety instructions could result in serious injury or death.

### TRAINING

1. Read, understand, and follow all instructions on the machine and in the manual(s) before attempting to assemble and operate. Keep this manual in a safe place for future and regular reference and for ordering replacement parts.
2. Be familiar with all controls and their proper operation. Know how to stop the machine and disengage them quickly.
3. Never allow children under 16 years old to operate this machine. Children 16 years old and over should read and understand the operation instructions and safety rules in this manual and should be trained and supervised by a parent.
4. Never allow adults to operate this machine without proper instruction.
5. Keep bystanders, helpers, pets, and children at least 75 feet from the machine while it is in operation. Stop machine if anyone enters the area.
6. Never run an engine indoors or in a poorly ventilated area. Engine exhaust contains carbon monoxide, an odorless and deadly gas.
7. Do not put hands and feet near rotating parts or in the feeding chambers and discharge opening. Contact with the rotating impeller can amputate fingers, hands, and feet.
8. Never attempt to unclog either the feed intake or discharge opening, remove or empty bag, or inspect and repair the machine while the engine is running. Shut the engine off and wait until all moving parts have come to a complete stop. Disconnect the spark plug wire and ground it against the engine.
2. Always wear safety glasses or safety goggles during operation or while performing an adjustment or repair, to protect eyes. Thrown objects which ricochet can cause serious injury to the eyes.
3. Wear sturdy, rough-soled work shoes and close-fitting slacks and shirts. Loose fitting clothes or jewelry can be caught in movable parts. Never operate this machine in bare feet or sandals. Wear leather work gloves when feeding material in the chipper chute.
4. Before starting, check all bolts and screws for proper tightness to be sure the machine is in safe working condition. Also, visually inspect machine for any damage at frequent intervals.
5. Maintain or replace safety and instructions labels, as necessary.
6. To avoid personal injury or property damage use extreme care in handling gasoline. Gasoline is extremely flammable and the vapors are explosive. Serious personal injury can occur when gasoline is spilled on yourself or your clothes which can ignite. Wash your skin and change clothes immediately.
  - a. Use only an approved gasoline container.
  - b. Extinguish all cigarettes, cigars, pipes, and other sources of ignition.
  - c. Never fuel machine indoors.
  - d. Never remove gas cap or add fuel while the engine is hot or running.
  - e. Allow engine to cool at least two minutes before refueling.
  - f. Never over fill fuel tank. Fill tank to no more than 1/2 inch below bottom of filler neck to provide space for fuel expansion.
  - g. Replace gasoline cap and tighten securely.
  - h. If gasoline is spilled, wipe it off the engine and equipment. Move machine to another area. Wait 5 minutes before starting the engine.
  - i. Never store the machine or fuel container inside where there is an open flame, spark, or pilot light (e.g. furnace, water heater, space heater, clothes dryer, etc.)

### PREPARATION

1. Thoroughly inspect the area where the equipment is to be used. Remove all rocks, bottles, cans, or other foreign objects which could be picked up or thrown and cause personal injury or damage to the machine.

- j. To reduce a fire hazard, keep machine free of grass, leaves, or other debris build-up. Clean up oil or fuel spillage and remove any fuel soaked debris.
- k. Allow machine to cool at least 5 minutes before storing.

## OPERATION

1. Do not put hands and feet near rotating parts or in the feeding chambers and discharge opening. Contact with the rotating impeller can amputate fingers, hands, and feet.
2. Before starting the machine, make sure the chipper chute, feed intake, and cutting chamber are empty and free of all debris.
3. Thoroughly inspect all material to be shredded and remove any metal, rocks, bottles, cans, or other foreign objects which could cause personal injury or damage to the machine.
4. If it becomes necessary to push material through the shredder hopper, use a small diameter stick. Do not use your hands or feet.
5. If the impeller strikes a foreign object or if your machine should start making an unusual noise or vibration, immediately shut the engine off. Allow the impeller to come to a complete stop. Disconnect the spark plug wire, ground it against the engine and perform the following steps:
  - a. Inspect for damage.
  - b. Repair or replace any damaged parts.
  - c. Check for any loose parts and tighten to assure continued safe operation.
6. Do not allow an accumulation of processed material to build up in the discharge area. This can prevent proper discharge and result in kickback of material through the feed opening.
7. Do not attempt to shred or chip material larger than specified on the machine or in this manual. Personal injury or machine damage could result.
8. Never attempt to unclog either the feed intake or discharge opening while the engine is running. Shut the engine off, wait until all moving parts have stopped, disconnect the spark plug wire and ground it against the engine before clearing debris.
9. Never operate without the shredder hopper, chipper chute, or discharge chute properly attached to the machine. Never empty or change discharge bag while the engine is running.
10. Keep all guards, deflectors and safety devices in place and operating properly.
11. Keep your face and body back and to the side of the chipper chute while feeding material into the machine to avoid accidental kickback injuries.
12. Never operate this machine without good visibility or light.
13. Do not operate this machine on a paved, gravel or non-level surface.
14. Do not operate this machine while under the influence of alcohol or drugs.
15. Muffler and engine become hot and can cause a burn. Do not touch.
16. Never pick up or carry machine while the engine is running.

## MAINTENANCE AND STORAGE

1. Never tamper with safety devices. Check their proper operation regularly.
2. Check bolts and screws for proper tightness at frequent intervals to keep the machine in safe working condition. Also, visually inspect machine for any damage and repair, if needed.
3. Before cleaning, repairing, or inspecting, stop the engine and make certain the impeller and all moving parts have stopped. Disconnect the spark plug wire and ground it against the engine to prevent unintended starting.
4. Do not change the engine governor settings or overspeed the engine. The governor controls the maximum safe operating speed of the engine.
5. Maintain or replace safety and instruction labels, as necessary.
6. Follow this manual for safe loading, unloading, transporting, and storage of this machine.
7. Never store the machine or fuel container inside where there is an open flame, spark or pilot light such as a water heater, furnace, clothes dryer, etc.
8. Always refer to the operator's manual for proper instructions on off-season storage.
9. If the fuel tank has to be drained, do this outdoors.
10. Observe proper disposal laws and regulations for gas, oil, etc. to protect the environment.



**WARNING: - YOUR RESPONSIBILITY:** Restrict the use of this power machine to persons who read, understand and follow the warnings and instructions in this manual and on the machine.

**NOTE:** Not all safety labels shown may apply to your chipper shredder.

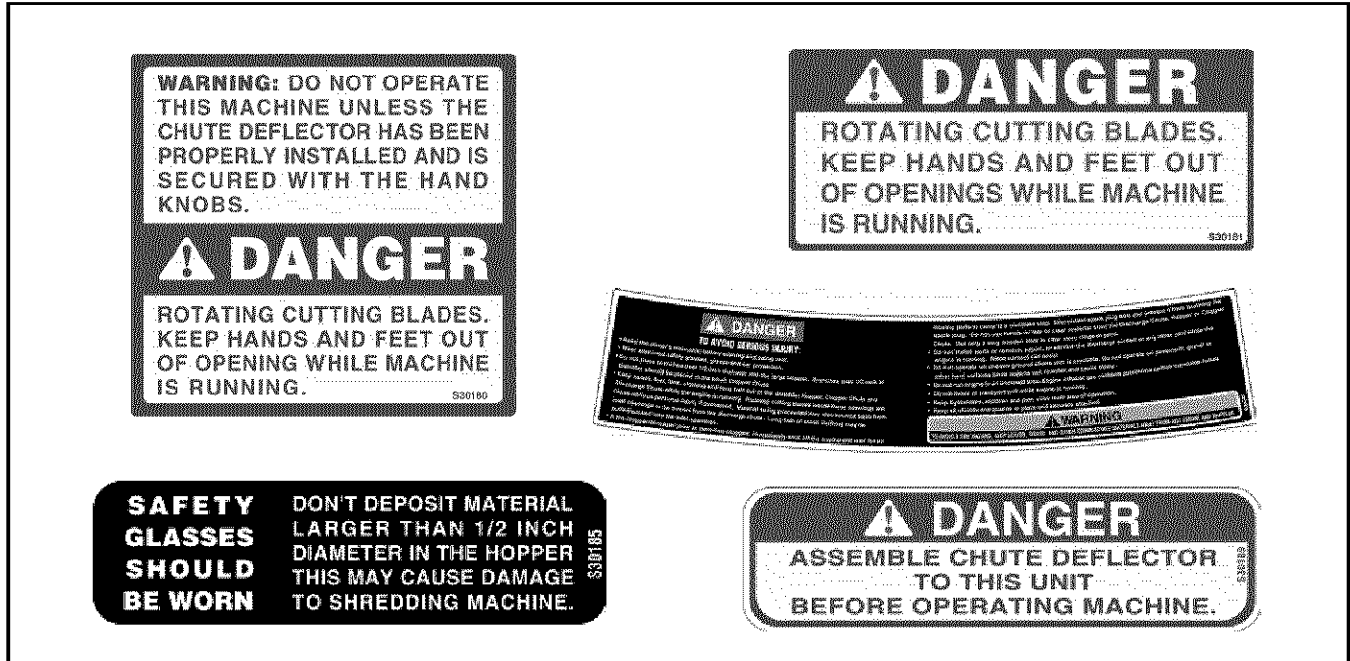

## SECTION 2: ASSEMBLING YOUR CHIPPER SHREDDER

**IMPORTANT:** This unit is shipped without gasoline or oil in the engine. Be certain to service engine with gasoline and oil as instructed in the separate engine manual before operating your machine.

**NOTE:** Reference to right or left hand side of the chipper shredder is observed from the operating position.

### Removing Unit From Carton

- Remove staples, break glue on top flaps, or cut tape at carton end and peel along top flap to open carton.
- Remove loose parts if included with unit (i.e., operator's manual, etc.)
- Cut along corners, lay carton down flat, and remove packing material.
- Roll or slide unit out of carton and check carton thoroughly for loose parts.

### Loose Parts In Carton (See Figure 1)

- Hopper Assembly
- Discharge Chute
- Chipper Chute (463 thru 465)
- Bag (Not Shown)
- Tamper Plug (If Equipped)
- Safety Goggles (Not Shown)

### Disconnecting Spark Plug Wire

Before setting up your chipper shredder, disconnect the spark plug wire from the spark plug and ground against the engine.

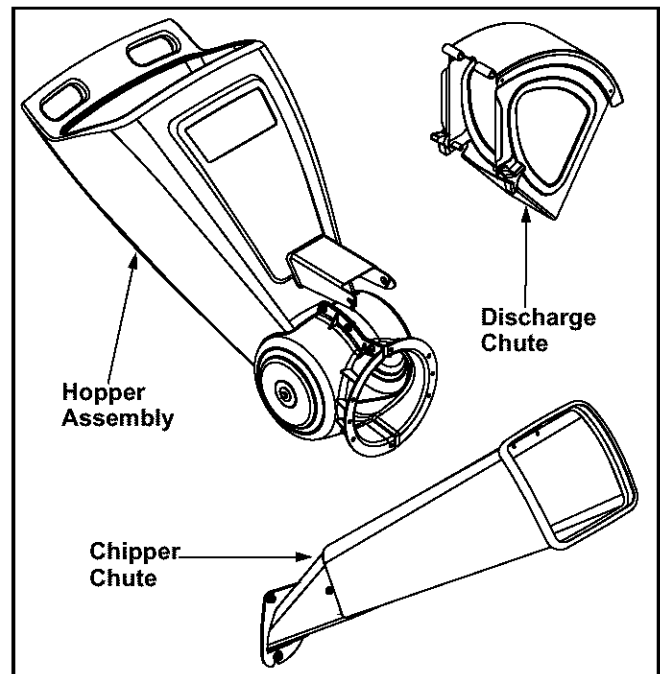

Figure 1

## Attaching The Hopper Assembly (All Models)

- Remove six hex nuts and washers from the weld studs on the impeller housing. Do not remove the support plate. See Figure 2.
- Place hopper assembly into position in front of impeller housing, aligning holes in hopper assembly collar with weld studs.

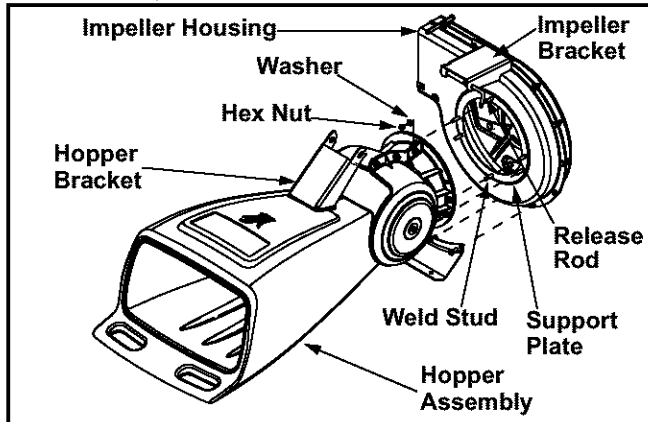

Figure 2

- Slide hopper assembly onto weld studs and replace washers and hex nuts. Do not tighten completely.
- Lift hopper assembly up to impeller bracket assembly and slide the release rod out slightly to hook the hopper bracket onto the rod. See Figure 2.
- Tighten the six hex nuts that secure hopper assembly to impeller housing and also tighten the hex nuts that secure hopper bracket to hopper assembly.

## Attaching The Discharge Chute (All Models)

- Remove the wing knobs from each side of the lower impeller housing. See Figure 3.

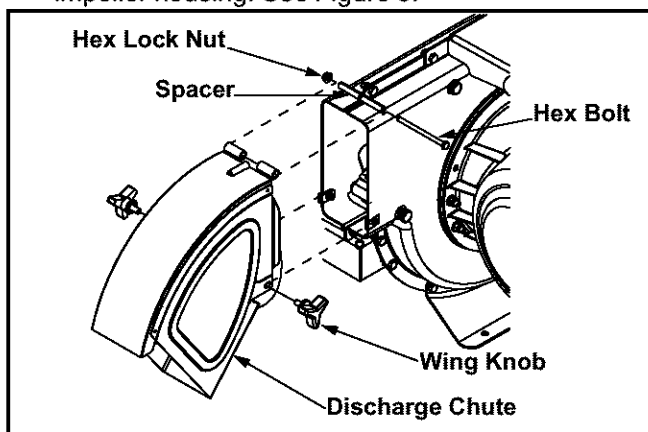

Figure 3

- Remove the hex lock nut, spacers, and hex bolt from the top of the impeller housing.
- Align the discharge chute in position on the discharge opening and insert hex bolt with spacer through hinge on discharge chute (spacers fit inside of hinges). See Figure 3.

- Place second spacer over hex bolt inside other hinge and secure with hex lock nut.
- Secure both sides of discharge chute to impeller housing using wing knobs previously removed.

## Attaching The Chipper Chute

(Model 463 Thru 465 Only)

- Remove the three cupped washers and hex nuts from weld studs besides the opening on the side of the impeller housing. See Figure 4.

**NOTE:** Engine is not shown for clarity.

- Remove the hex bolts, lock nuts, and flat washers from the two holes on the upper end of the support brace.

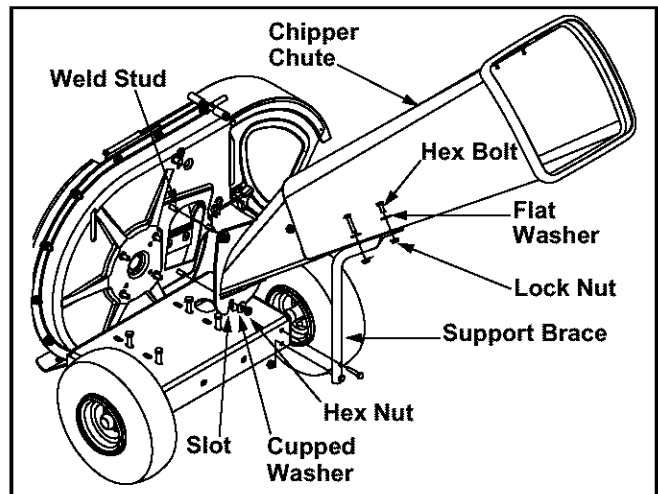
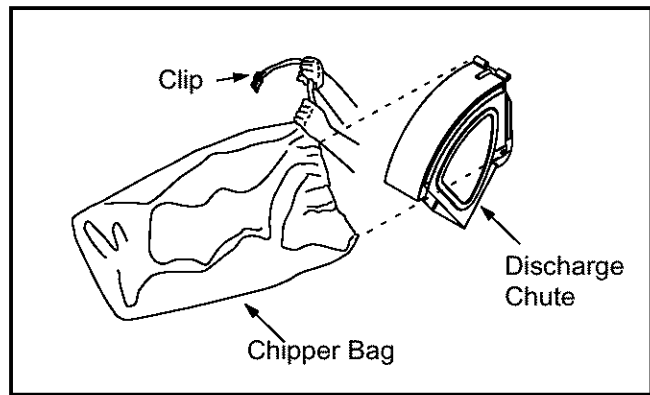

Figure 4

- Align the chipper chute over the weld studs, so the slot in the bottom of the chute is facing down.
- Secure chipper chute with the three cupped washers (cupped side against the chipper chute) and hex nuts previously removed. Do not tighten the nuts at this time.
- The chipper shredder was shipped with one end of the support brace already secured to the lower frame. **Loosen but do not remove** the bolts securing the brace to the frame.
- Align the holes in the chute with the holes in the top of the brace and attach brace to chipper chute with hardware previously removed. Tighten securely.
- Tighten the bolts securing the support brace to the frame.
- Tighten the three nuts on the weld studs holding the chipper chute to the impeller housing.

## Attaching The Bag (All Models)

- To attach the bag, place the opening of the bag completely over the discharge chute.
- Pull on the drawstring until the bag is tight around discharge chute opening.
- Clip the drawstring back on itself, tight against the discharge chute to secure into position.



## SECTION 3: KNOW YOUR CHIPPER SHREDDER

Read this operator's manual and safety rules before operating your chipper shredder. Compare the illustrations in Figure 5 with your unit to familiarize yourself with the location of various controls and adjustments. Save this manual for future reference.

### Starter Handle

The starter handle is located on the engine. Pull the starter handle to start engine. See Figure 5.

### Release Rod

The release rod is located on the impeller bracket assembly and it is used to release or lock the hopper when raising or lowering. See Figure 5.

### Chipper Chute

Allow twigs and small branches up to 3" in diameter on models 463 thru 465 and 2" in diameter on models 462 to be fed into the impeller for chipping. See Figure 5.

### Hopper Assembly

Allow leaves and small branches up to 1/2 diameter to be fed into the impeller for chipping and shredding. Material can be raked into hopper assembly by lowering the hopper assembly. See Figure 5.

### Tamper Plug (If Equipped)

The tamper plug is designed to insert in the chipper chute to push material toward the impeller. See Figure 5.

### Engine Controls

See the separate engine manual for the location and function of the controls on the engine.

### Stopping Engine

- Move throttle control lever to STOP or OFF position.
- Disconnect spark plug wire from spark plug and ground against the engine.

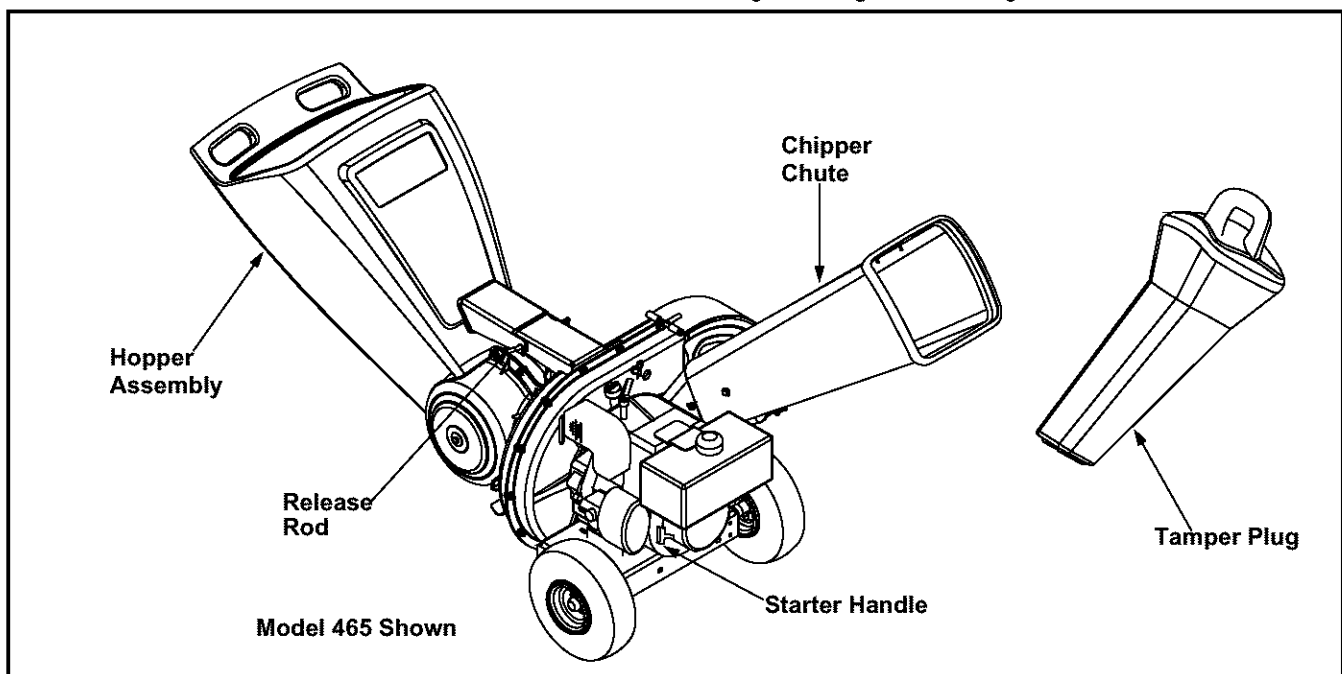

Figure 5

## SECTION 4: OPERATING YOUR CHIPPER SHREDDER



**WARNING:** The operation of any chipper shredder can result in foreign objects being thrown into the eyes, which can damage your eyes severely. Always wear the safety glasses provided with this unit or eye shields before chipping or shredding and while performing any adjustments or repairs.

### Gas And Oil Fill-Up

Service the engine with gasoline and oil as instructed in the separate engine manual packed with your chipper shredder. Read instructions carefully.



**WARNING:** Never fill fuel tank indoors with engine running or until the engine has been allowed to cool for at least two minutes after running.

### Starting Engine

- Attach spark plug wire to spark plug. Make certain the metal cap on the end of the spark plug is fastened securely over the metal tip on the spark plug.
- **Engines with choke lever:**  
Move choke lever on engine to CHOKE position. (A warm engine may not require choking).
- **Engines with primer:**  
Prime engine as instructed in separate engine manual.
- The throttle control lever is located on the engine. Move engine throttle control lever to FAST or START position.
- Grasp starter handle and pull rope out slowly until engine reaches start of compression cycle (rope will pull slightly harder at this point).

**NOTE:** A noise will be heard when finding the start of the compression cycle. This noise is caused by the flails and fingers, which are part of the shredding mechanism, and it should be expected until the impeller reaches full speed.

- Pull rope with a rapid, continuous, full arm stroke. Keep a firm grip on starter handle. Let rope rewind slowly.
- Repeat the previous steps until engine fires. When engine starts, move choke control (if equipped) gradually to RUN position.



**WARNING:** Never run the engine indoors or in a poorly ventilated area. Engine exhaust contains carbon monoxide, an odorless and deadly gas.

### To Empty Bag

- Un-clip drawstring and loosen bag from discharge chute opening.
- Empty bag and reattach to the discharge chute opening. Pull on the drawstring until the bag is tight around the chute opening and clip the drawstring tight against the discharge chute.

### Lowering The Hopper Assembly

- With one hand grasp the handle at the top of the hopper assembly and lift slightly.
- With the other hand pull out on the release rod and lower the hopper assembly to the ground. See Figure 6.

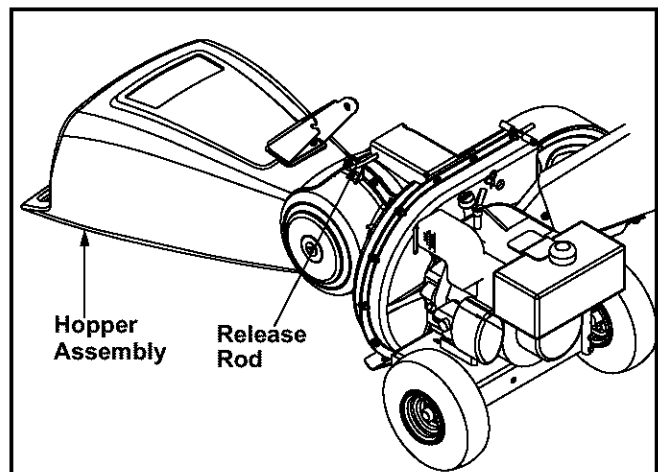

Figure 6

### Using The Chipper Shredder

Yard waste such as leaves and pine needles can be raked up through the hopper assembly for shredding. After material has been shredded by the flail blades on the impeller assembly, it will be discharged out of opening or into catcher bag. Do not attempt to shred or chip any material other than vegetation found in a normal yard (i.e. branches, leaves, twigs, etc.) Avoid fibrous plants such as tomato vines until they are thoroughly dried out. Twigs and small branches up to 3" in diameter on models 463 thru 465 and 2" in diameter on models 462 can be fed into the chipper chute. If equipped, use the tamper plug to push material into the chipper chute. See Figure 7.



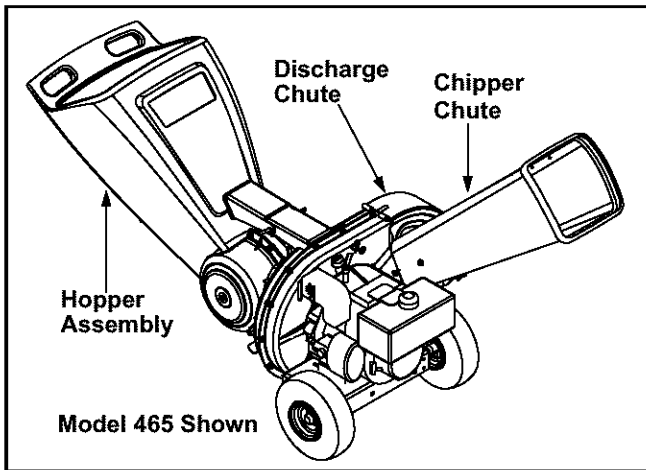

Figure 7

**IMPORTANT:** The flail screen is located inside the housing in the discharge area. If the flail screen becomes clogged, remove and clean as instructed in SECTION 5: MAINTAINING YOUR CHIPPER SHREDDER. For best performance, it is also important to keep the chipper blade sharp.

## SECTION 5: MAINTAINING YOUR CHIPPER SHREDDER

### Customer Responsibilities

MAINTENANCE SCHEDULE		Before each use	Every 25 hours	Every 50 hours	Every 100 hours	Once a season	Before storage	SERVICE DATES					
PRODUCT	Lubricate Release Bracket					✓							
	Lubricate Hopper Assembly					✓							
	Lubricate Discharge Chute					✓							
	Check Chipper Blade		✓			✓							
ENGINE	Check Oil	✓											
	Change Oil		✓				✓						
	Clean Air Filter		✓			✓							
	Clean Engine	✓					✓						
	Check Spark Plug			✓		✓							



**WARNING:** Always stop engine, disconnect spark plug, and ground against engine before cleaning, lubricating or doing any kind of maintenance on your machine.

### Lubrication

**Release Rod:** Lubricate the release rod and spring with light oil once a season.

**Hopper Assembly:** Lubricate the pivot points on the hopper assembly with light oil once a season.

**Discharge Chute:** Lubricate the pivot points on the chute deflector with light oil once a season.

**Engine:** Follow the separate engine manual packed with you unit for lubrication instructions.

### Maintenance

#### Engine

Refer to the separate engine manual for all engine maintenance instructions.

- Check **engine oil level** before each use as instructed in the separate engine manual packed with your unit. Read and follow instructions carefully.
- Clean **air cleaner** every 25 hours under normal conditions or once a season. Clean every few hours under extremely dusty conditions. To service the air cleaner, refer to the separate engine manual packed with your unit.

- The **spark plug** should be cleaned and the gap reset once a season. Check engine manual for correct plug type and gap specifications.

## Removing The Flail Screen

If the discharge area becomes clogged, remove the flail screen and clean area as follows:

- Stop the engine and make certain the chipper shredder has come to a complete stop.
- Disconnect spark plug wire from spark plug and ground against the engine.
- Remove the two wing knobs on each side of the discharge chute and lift the discharge chute up to keep it out of the way. See Figure 8.

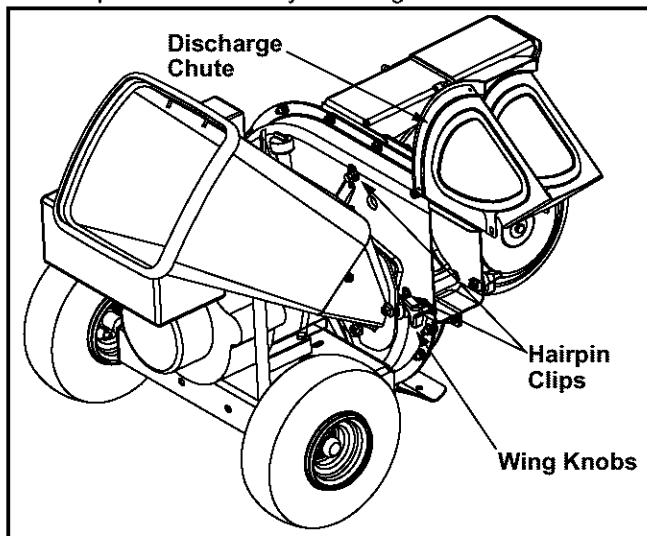

Figure 8

- Remove the two hairpin clips from each clevis pin which extend through the housing and remove the pins. See Figure 8.
- Remove the flail screen from inside the housing and clean the screen by scraping or washing with water.
- Reinstall the screen, making certain to reassemble the flail screen with the curve side down.
- Reattach the discharge chute with the hardware previously removed and connect the bag (if equipped) to unit.

## Sharpening Or Replacing Chipper Blades

- Disconnect the spark plug wire and ground against the engine.
- Remove the flail screen as instructed in the previous section.
- Remove the chipper chute by removing three hex nuts and washers.

### Models 463 or 465

- Remove the chipper chute support brace from the frame by removing the hex bolts.

### All Models

- Rotate the impeller assembly by hand until you locate one of the two chipper blades in the chipper chute opening.
- Remove the blade using a 3/16" allen wrench on the outside of the blade and an adjustable wrench on the impeller assembly. See Figure 9.

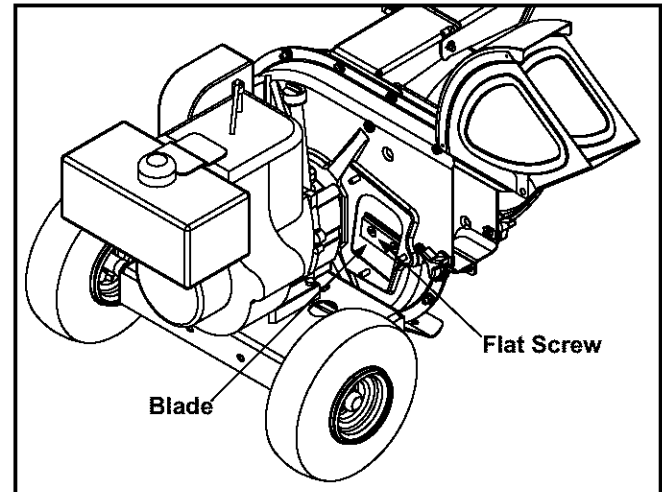

Figure 9

- Rotate the impeller to expose other blade and remove in the same manner.
- Replace or sharpen blades.
- When sharpening the blade, protect hands by using gloves and follow the original angle of grind. Also, make sure to remove an equal amount from each blade and torque to 250 - 300 in. lbs.

**NOTE:** Make certain blades are reassembled with the sharp edge facing upward.

## Sharpening Or Replacing The Shredder Blade

- Disconnect the spark plug wire and ground against the engine.
- Lower the hopper assembly and block up the housing.
- Remove the six hex lock nuts and flat washers from the weld studs on the flail housing.
- Separate the hopper assembly from the impeller assembly and remove the support plate.

**NOTE:** When reassembling the support plate, make certain the embossed tab faces inward towards the impeller.

- Remove the two wing knobs and cupped washers that secure the discharge chute and raise the chute.
- Insert a 1/2" or 3/4" diameter pipe through the flail screen into the impeller to keep it from turning or

remove the flail screen and insert a piece of wood into the chute opening.

- Remove the two outside screws on the blade, using a 3/16" allen wrench and a 1/2" wrench. See Figure 10.

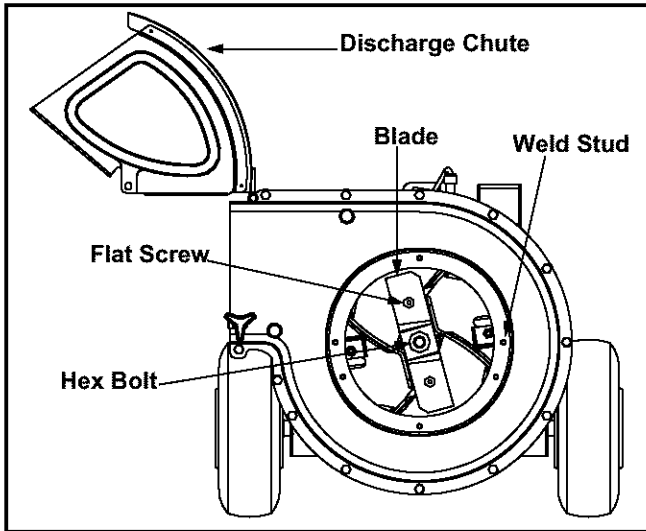

Figure 10

- Remove the blade by removing the center bolt, lock washer, and flat washer.

**NOTE:** Use caution when removing the blade to avoid contacting the weld studs on the housing.

- When sharpening the blade, follow the original angle of grind as a guide. It is extremely important that each cutting edge receives an equal amount of grinding to prevent an unbalanced blade.
- An unbalanced blade will cause excessive vibration when rotating at high speeds and may cause damage to the unit. The blade can be tested by balancing it on a screwdriver or nail. Remove metal from the heavy side until it is balanced evenly.
- When reassembling the blade, tighten center bolt to between 550 and 700 in.-lbs. and the two out bolts to between 250 and 350 in.-lbs.

### Storing Your Chipper Shredder

- Clean the equipment thoroughly.
- Wipe equipment with an oiled rag to prevent rust.
- Refer to engine manual for correct engine storage instructions
- Store unit in a clean, dry area. Do not store next to corrosive materials such as fertilizer.

## SECTION 6: TROUBLESHOOTING

Problem	Cause	Remedy
Engine fails to start	<ol style="list-style-type: none"> <li>1. Spark plug wire disconnected.</li> <li>2. Fuel tank empty or stale fuel.</li> <li>3. Throttle control lever not in correct starting position. (If Equipped)</li> <li>4. Choke not in CHOKE position. (If Equipped)</li> <li>5. Engine not primed.</li> <li>6. Blocked fuel line.</li> <li>7. Faulty spark plug.</li> </ol>	<ol style="list-style-type: none"> <li>1. Connect wire to spark plug.</li> <li>2. Fill tank with clean, fresh gasoline.</li> <li>3. Move throttle lever to FAST position.</li> <li>4. Move choke to CHOKE position.</li> <li>5. Prime engine.</li> <li>6. Clean fuel line.</li> <li>7. Clean, adjust gap, or replace.</li> </ol>
Engine runs erratic	<ol style="list-style-type: none"> <li>1. Spark plug wire loose.</li> <li>2. Unit running on CHOKE. (If Equipped)</li> <li>3. Blocked fuel line or stale fuel.</li> <li>4. Water or dirt in fuel system.</li> <li>5. Dirty air cleaner.</li> <li>6. Carburetor out of adjustment.</li> </ol>	<ol style="list-style-type: none"> <li>1. Connect and tighten spark plug wire.</li> <li>2. Move choke lever to OFF position.</li> <li>3. Clean fuel line; fill tank with clean, fresh gasoline</li> <li>4. Drain fuel tank. Refill with fresh fuel.</li> <li>5. Clean or replace air cleaner.</li> <li>6. See authorized service dealer.</li> </ol>
Too much vibration	<ol style="list-style-type: none"> <li>1. Loose parts or damaged impeller.</li> </ol>	<ol style="list-style-type: none"> <li>1. See authorized service dealer.</li> </ol>
Engine overheats	<ol style="list-style-type: none"> <li>1. Engine oil level low.</li> <li>2. Dirty air cleaner.</li> <li>3. Carburetor not adjusted properly.</li> </ol>	<ol style="list-style-type: none"> <li>1. Fill crankcase with proper oil.</li> <li>2. Clean or replace air cleaner.</li> <li>3. See authorized service dealer.</li> </ol>
Occasional skip (hesitates) at high speed	<ol style="list-style-type: none"> <li>1. Spark plug gap too close.</li> </ol>	<ol style="list-style-type: none"> <li>1. Adjust gap to .030".</li> </ol>
Unit does not discharge	<ol style="list-style-type: none"> <li>1. Discharge chute clogged.</li> <li>2. Foreign object lodged in impeller.</li> <li>3. Low engine RPM.</li> </ol>	<ol style="list-style-type: none"> <li>1. Stop engine immediately and disconnect spark plug wire. Clean flail screen and inside of discharge opening.</li> <li>2. Stop engine and disconnect spark plug wire. Remove lodged object.</li> <li>3. Always run engine at full throttle.</li> </ol>
Rate of discharge slows considerably or composition of discharged material changes.	<ol style="list-style-type: none"> <li>1. Low engine RPM.</li> <li>2. Chipper blade dull.</li> </ol>	<ol style="list-style-type: none"> <li>1. Always run engine at full throttle.</li> <li>2. Replace chipper blade or see your authorized service dealer.</li> </ol>

**NOTE:** For repairs beyond the minor adjustments listed above, contact your nearest authorized service dealer.

**Model Series 462 Thru 465**

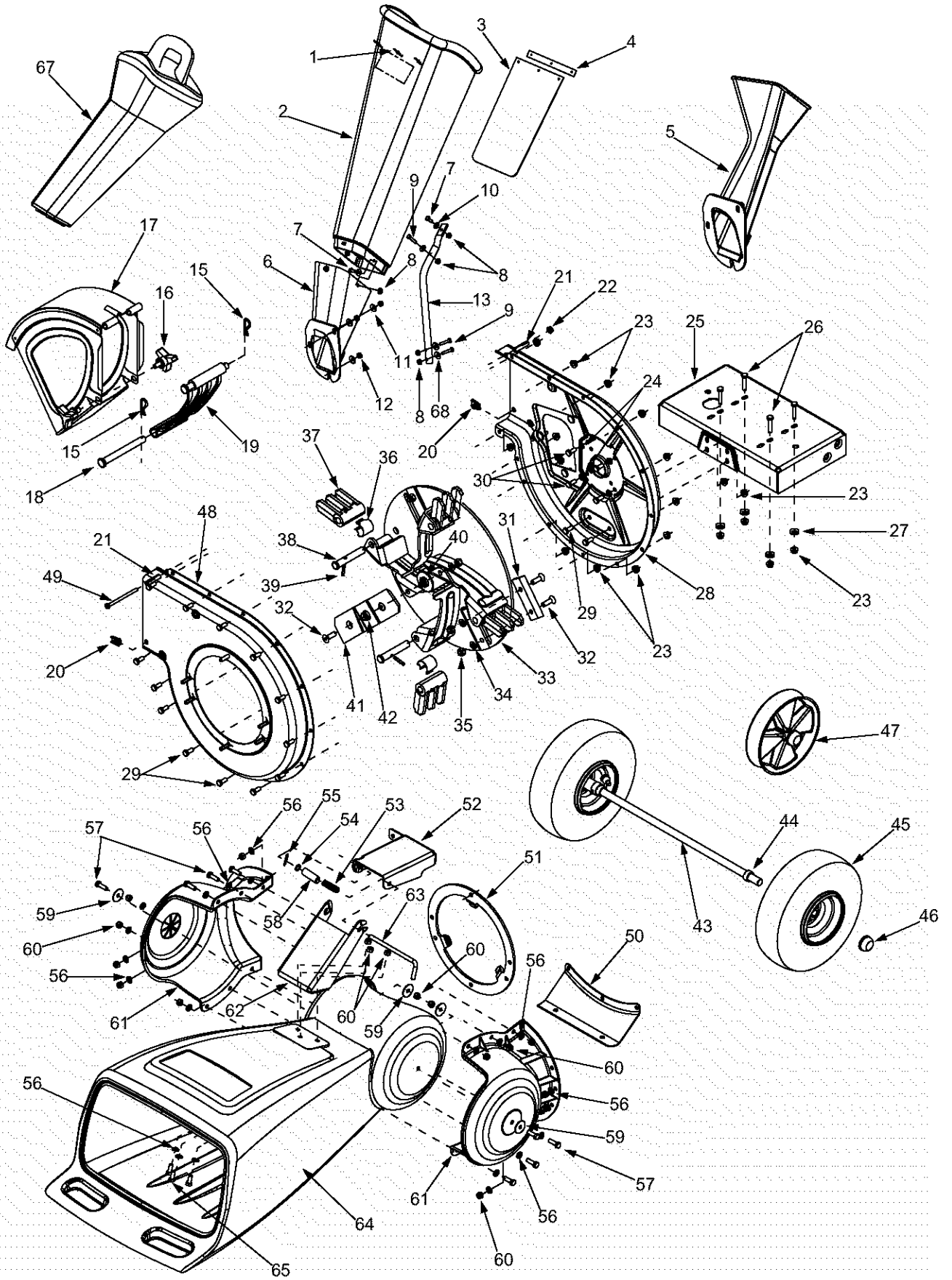

## Model Series 462 Thru 465

Ref. No.	Part No.	Part Description	Ref. No.	Part No.	Part Description
1.	728-0175	Pop Rivet	37.	719-0329	Flail Blade
2.	731-1899	Chipper Chute	38.	711-0833B	Clevis Pin
3.	735-0249	Chute Flap	39.	715-0166	Pin
4.	781-0633	Chute Flap Strip	40.	736-0247	Flat Washer 3/8 x 1.25
5.	681-0095	Chipper Chute †	41.	742-0571	Shredder Blade
6.	681-0068A	Chipper Chute Assembly	42.	710-1254	Hex Cap Screw 3/8-24 x 2.25
7.	710-0751	Hex Cap Screw 1/4 -20 x.620	43.	738-0813	Axle Assembly
8.	712-3027	Hex Lock Nut 1/4-20		738-0814	Axle Assembly †
9.	710-0106	Hex Cap Screw 1/4-20 x 1.25	44.	750-0786	Spacer
10.	736-0173	Flat Washer.28 ID x.74 OD	45.	734-1597A	Wheel Assembly 10.0 x 4.0
11.	736-0242	Bell Washer.340 ID x.872 OD	46.	726-0214	Push Cap
12.	712-3010	Hex Nut 5/16-18	47.	634-04009	Wheel Complete 10 x 4 x 4 †
13.	749-1004	Support Brace		734-1600	Wheel Assembly 10.0 x 2.5 †
15.	714-0149B	Cotter Pin	48.	681-0004A	Outer Impeller Housing Assembly
16.	681-0048	Wing Knob 5/16-18	49.	710-0825	Hex Cap Screw 1/4-20 x 3.75
17.	681-0094	Discharge Chute Assembly	50.	781-0515	Support Bracket
18.	711-0835	Clevis Pin	51.	781-0574	Support Plate
19.	781-0457	Flail Screen	52.	681-0104	Impeller Bracket Assembly
20.	726-0211	U-Nut 5/16-18	53.	732-0306	Compression Spring 1.75
21.	750-0793	Spacer	54.	736-0117	Flat Washer
22.	712-3027	Hex Lock Nut 1/4-20	55.	714-0104	Cotter Pin
23.	712-3004A	Hex Lock Nut 5/16-18	56.	736-0264	Flat Washer.330 ID x.630 OD
24.	736-0119	Lock Washer 5/16	57.	710-0376	Hex Cap Screw 5/16-18 x 1.0
25.	681-0184	Frame	58.	748-0453	Spacer,.375 ID x 2.50 LG
26.	710-0805	Hex Cap Screw 5/16-18 x 1.50	59.	736-0362	Flat Washer.320 ID x 1.25 OD
27.	736-0170	Bell Washer 5/16 x 1.0	60.	712-0429	Hex Lock Nut 5/16-18
28.	681-0117	Inner Impeller Housing Assembly	61.	731-1710	Hopper Collar
29.	710-3008	Hex Cap Screw 5/16-18 x.75	62.	681-0123	Hopper Bracket Assembly
30.	710-0157	Hex Cap Screw 5/16-24 x.75	63.	711-1128	Lock Rod
31.	781-0490	Chipper Blade	64.	731-1707	Hopper Assembly
32.	710-1054	Hex Cap Screw 5/16-24 x 1.0	65.	710-3008	Hex Cap Screw 5/16-18 x.75
33.	681-0030	Impeller Assembly	67.	731-1617	Tamper Plug (If Equipped)
34.	736-0119	Lock Washer 5/16	68.	736-0451	Washer,.320 ID x.93 OD
35.	712-0411	Hex Lock Nut 5/16-24	69.	662-04022	Chipper Bag Assembly ^
36.	781-0735	Pin Clip			

† Model 462 Only

^ Not Shown

## Notes

# MANUFACTURER'S LIMITED WARRANTY FOR:



The limited warranty set forth below is given by MTD LLC with respect to new merchandise purchased and used in the United States, its possessions and territories.

MTD LLC warrants this product against defects for a period of two (2) years commencing on the date of original purchase and will, at its option, repair or replace, free of charge, any part found to be defective in materials or workmanship. This limited warranty shall only apply if this product has been operated and maintained in accordance with the Operator's Manual furnished with the product, and has not been subject to misuse, abuse, commercial use, neglect, accident, improper maintenance, alteration, vandalism, theft, fire, water, or damage because of other peril or natural disaster. Damage resulting from the installation or use of any accessory or attachment not approved by MTD LLC for use with the product(s) covered by this manual will void your warranty as to any resulting damage.

Normal wear parts or components thereof are subject to separate terms as follows: All normal wear parts or component failures will be covered on the product for a period of 90 days regardless of cause. After 90 days, but within the two year period, normal wear part failures will be covered ONLY IF caused by defects in materials or workmanship of OTHER component parts. Normal wear parts and components include, but are not limited to: batteries, belts, blades, blade adapters, grass bags, rider deck wheels, seats, snow thrower skid shoes, shave plates, auger spiral rubber, tires.

**HOW TO OBTAIN SERVICE:** Warranty service is available, WITH PROOF OF PURCHASE, through your local authorized service dealer. To locate the dealer in your area, check your Yellow Pages, or contact MTD LLC at P.O. Box 361131, Cleveland, Ohio 44136-0019, 1-800-800-7310, 1-330-220-4683 or log on to our Web site at [www.mtdproducts.com](http://www.mtdproducts.com).

This limited warranty does not provide coverage in the following cases:

- a. The engine or component parts thereof. These items carry a separate manufacturer's warranty. Refer to the applicable manufacturer's warranty for terms and conditions.
- b. Log splitter pumps, valves, and cylinders have a separate one year warranty.
- c. Routine maintenance items such as lubricants, filters, blade sharpening, tune-ups, brake adjustments, clutch adjustments, deck adjustments, and normal deterioration of the exterior finish due to use or exposure.
- d. MTD LLC does not extend any warranty for products sold or exported outside of the United States, its possessions and territories, except those sold through MTD LLC's authorized channels of export distribution.
- e. Parts that are not genuine MTD parts are not covered by this warranty.
- f. Service completed by someone other than an authorized service dealer is not covered by this warranty.
- g. Transportation charges and service calls are not covered.

**No implied warranty, including any implied warranty of merchantability of fitness for a particular purpose, applies after the applicable period of express written warranty above as to the parts as identified. No other express warranty, whether written or oral, except as mentioned above, given by any person or entity, including a dealer or retailer, with respect to any product, shall bind MTD LLC. During the period of the warranty, the exclusive remedy is repair or replacement of the product as set forth above.**

**The provisions as set forth in this warranty provide the sole and exclusive remedy arising from the sale. MTD LLC shall not be liable for incidental or consequential loss or damage including, without limitation, expenses incurred for substitute or replacement lawn care services or for rental expenses to temporarily replace a warranted product.**

Some states do not allow the exclusion or limitation of incidental or consequential damages, or limitations on how long an implied warranty lasts, so the above exclusions or limitations may not apply to you.

In no event shall recovery of any kind be greater than the amount of the purchase price of the product sold. **Alteration of safety features of the product shall void this warranty.** You assume the risk and liability for loss, damage, or injury to you and your property and/or to others and their property arising out of the misuse or inability to use the product.

This limited warranty shall not extend to anyone other than the original purchaser or to the person for whom it was purchased as a gift.

**HOW STATE LAW RELATES TO THIS WARRANTY: This limited warranty gives you specific legal rights, and you may also have other rights which vary from state to state.**