



**SAFETY FIRST!**

Before operating this equipment, read this Owner's Manual and the separate manual supplied by the engine manufacturer.

Model

12183

## **OWNER'S MANUAL**

### **5.5 HP Model Tiller**

- **Safety**
- **Assembly**
- **Features and Controls**
- **Operation**
- **Maintenance**
- **Parts List**



Dear Owner:

You now own one of the finest rear-tine rototillers available. Your new tiller allows you to till and cultivate your garden with ease, and accomplish dozens of other property management projects as well. Your tiller is famous for its ruggedness, performance and high-quality engineering. We know you'll enjoy using it.

Please carefully read this Manual. It tells you how to safely and easily assemble, operate and maintain your machine. *Be sure that you and any other operators carefully follow the recommended safety practices at all times. Failure to do so could result in personal injury or property damage.*

Of course, if you should ever have any problems or questions, please contact your local authorized service dealer or call us Toll-Free (see back cover of this manual).

We want to be sure that you are completely satisfied at all times.

---

**See back cover for Customer Service information.**

---

### Safety Alert Symbol



This is a safety alert symbol. It is used in this manual and on the unit to alert you to potential hazards. When you see this symbol, read and obey the message that follows it. Failure to obey safety messages could result in personal injury or property damage.

**This machine meets voluntary safety standard B71.8 – 1996, which is sponsored by the Outdoor Power Equipment Institute, Inc., and is published by the American National Standards Institute.**

## **WARNING**

**The engine exhaust from this product contains chemicals known to the State of California to cause cancer, birth defects or other reproductive harm.**

## Table of Contents

<b>SECTION 1: SAFETY</b> .....	<b>3</b>
Safety Decals .....	5
<b>SECTION 2: ASSEMBLY</b> .....	<b>6</b>
Unpacking Instructions.....	6
Attach Handlebars .....	6
Attach Reverse Clutch Control Cable .....	7
Attach Forward Clutch Control Cable .....	7
Check Transmission Gear Oil Level .....	8
Add Motor Oil to Engine .....	8
Attach Wheel Gear Lever .....	8
Check Air Pressure in Tires .....	8
Check Hardware for Tightness.....	8
<b>SECTION 3: FEATURES &amp; CONTROLS</b> .....	<b>9</b>
Wheel Gear Lever .....	9
Forward Clutch Control Levers .....	9
Reverse Clutch Control.....	9
Depth Regulator Lever .....	9
Handlebar Height Adjustment .....	10
Engine Controls .....	10
<b>SECTION 4: OPERATION</b> .....	<b>11</b>
Break-in Operation.....	11
Starting/Stopping Engine.....	11
Operating the Tiller .....	12
Tilling Tips & Techniques .....	13
Loading and Unloading the Tiller .....	15
<b>SECTION 5: MAINTENANCE</b> .....	<b>15</b>
Maintenance Schedule.....	16
Tiller Lubrication.....	16
Check Hardware .....	16
Check Tire Pressure.....	16
Check for Oil Leaks.....	16
Transmission Gear Oil Service.....	16
Gear Oil Specifications.....	16
Engine Oil Service.....	17
Air Cleaner Service .....	17
Spark Plug Service .....	17
Spark Arrester Screen Service .....	17
Engine Cleaning.....	17
Carburetor/Governor Control Adjustments .....	17
Throttle Control Adjustment .....	17
Wheel Gear Cable Adjustment .....	17
Off Season Storage.....	18
Bolo Tines.....	18
Checking and Adjusting Tension on Clutch Belts.....	19
Forward Clutch Belt Removal and Installation .....	20
Reverse Clutch Belt Removal and Installation.....	21
<b>Tiller Attachments</b> .....	<b>22</b>
<b>Troubleshooting</b> .....	<b>23</b>
<b>Parts List</b> .....	<b>24</b>
<b>Customer Service Information</b> .....	<b>Back Cover</b>

**SPARK ARRESTER WARNING TO RESIDENTS OF CALIFORNIA AND SEVERAL OTHER STATES**

Under California law, and under the laws of several other states, you are not permitted to operate an internal combustion engine using hydrocarbon fuels on any forest, brush, hay, grain, or grass covered land; or land covered by any flammable agricultural crop without an engine spark arrester in continuous effective working order.

The engine on the unit is an internal combustion engine which burns gasoline, a hydrocarbon fuel, and must be equipped with a spark arrester muffler in continuous effective working order. The spark arrester must be attached to the engine exhaust system in such a manner that flames or heat from the system will not ignite flammable material. Failure of the owner/operator of the unit to comply with this regulation is a misdemeanor under California law (and other states) and may also be a violation of other state and/or federal regulations, laws, ordinances or codes. Contact your local fire marshal or forest service for specific information about which regulations apply in your area.

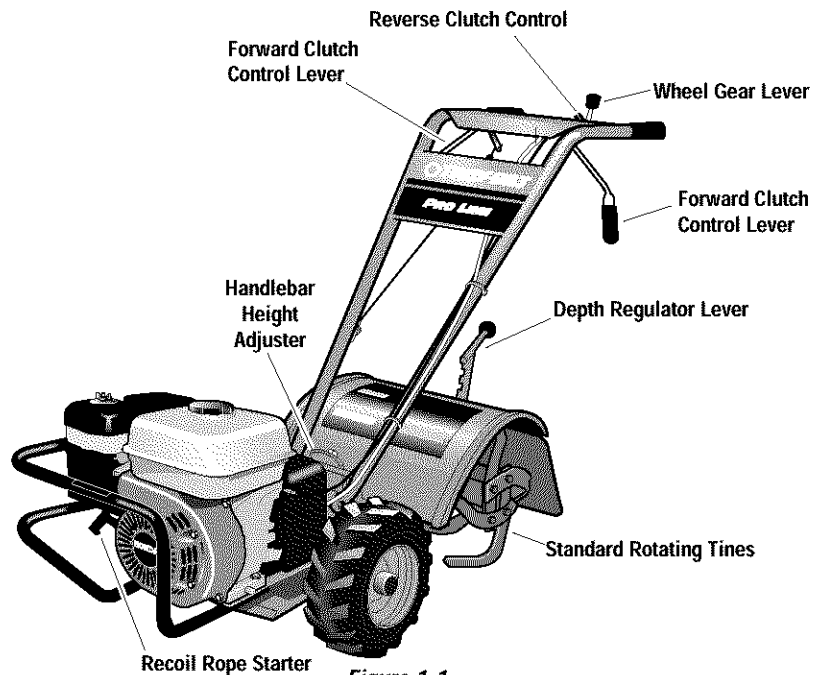

Figure 1-1

**TRAINING**

1. Carefully read this Owner's Manual, the separate Engine Owner's Manual, and any other literature you may receive. Be thoroughly familiar with the controls and the proper use of the tiller and its engine. Know how to stop the unit and disengage the controls quickly.
2. Never allow children to operate the tiller. Never allow adults to operate the tiller without proper instruction.
3. Keep the area of operation clear of all persons, particularly children and pets.
4. Keep in mind that the operator or user is responsible for accidents or hazards occurring to other people, their property, and themselves.

**PREPARATION**

1. Thoroughly inspect the area where the tiller is to be used and remove all foreign objects.
2. Be sure all controls are released and the Wheel Gear Lever is in ENGAGE before starting the engine.
3. Do not operate the tiller without wearing adequate outer garments. Avoid loose garments or jewelry that could get caught in moving parts.
4. Do not operate the tiller when barefoot or wearing sandals, sneakers, or light

footwear. Wear protective footwear that will improve footing on slippery surfaces.

5. Do not till near underground electric cables, telephone lines, pipes or hoses. If in doubt, contact your telephone or utility company.
6. Warning: Handle fuel with care; it is highly flammable and its vapors are explosive. Take the following precautions:
  - a. Store fuel in containers specifically designed for this purpose.
  - b. The gas cap shall never be removed or fuel added while the engine is running. Allow the engine to cool for several minutes before adding fuel.
  - c. Keep matches, cigarettes, cigars, pipes, open flames, and sparks away from the fuel tank and fuel container.
  - d. Fill fuel tank outdoors with extreme care. Never fill fuel tank indoors. Use a funnel or spout to prevent spillage.
  - e. Replace all fuel tank and container caps securely.
  - f. If fuel is spilled, do not attempt to start the engine, but move the machine away from the area of spillage and avoid creating any source of ignition until fuel vapors have dissipated.

7. Never make adjustments when engine is running (unless recommended by manufacturer).

**OPERATION**

1. Do not put hands or feet near or under rotating parts.
2. Exercise extreme caution when on or crossing gravel drives, walks, or roads. Stay alert for hidden hazards or traffic. Do not carry passengers.
3. After striking a foreign object, stop the engine, disconnect the spark plug wire and prevent it from touching the spark plug, carefully inspect the tiller for any damage, and repair the damage before restarting and operating the tiller.
4. Exercise caution to avoid slipping or falling.
5. If the unit should start to vibrate abnormally, stop the engine. Disconnect the spark plug wire and prevent it from touching the spark plug, and check immediately for the cause. Vibration is generally a warning of trouble.
6. Stop the engine, disconnect the spark plug wire and prevent it from touching the spark plug whenever you leave the operating position, before unclogging the tines, or when making any repairs, adjustments or inspections.

7. Take all possible precautions when leaving the machine unattended. Stop the engine. Disconnect spark plug wire and move it away from the spark plug. Move Wheel Gear Lever to ENGAGE.

8. Before cleaning, repairing, or inspecting, stop the engine and make certain all moving parts have stopped. Disconnect the spark plug wire and prevent it from touching the spark plug to prevent accidental starting.

9. Always keep the tiller tine hood flap down, unless using the tiller/furrower attachment.

10. Never use the tiller unless proper guards, plates, or other safety protective devices are in place.

11. Do not run engine in an enclosed area. Engine exhaust contains carbon monoxide gas, a deadly poison that is odorless, colorless, and tasteless.

12. Keep children and pets away.

13. **Never operate the tiller under engine power if the Wheel Gear Lever is in DIS-ENGAGE (FREEWHEEL). In this position, the wheels will not hold the tiller back and the revolving tines could propel the tiller rapidly, possibly causing loss of control.** Always move the Wheel Gear Lever to ENGAGE before starting the engine or engaging the tines/wheels with Forward Clutch Control or Reverse Clutch Control.

14. Be aware that the tiller may unexpectedly bounce upward or jump forward if the tines should strike extremely hard packed soil, frozen ground, or buried obstacles like large stones, roots, or stumps. If in doubt about the tilling conditions, always use the following operating precautions to assist you in maintaining control of the tiller:

- a. **Walk behind and to one side of the tiller, using one hand on the handlebars. Relax your arm, but use a secure hand grip.**
- b. **Use shallower depth regulator settings, working gradually deeper with each pass.**
- c. **Use slower engine speeds.**
- d. **Clear the tilling area of all large stones, roots and other debris.**
- e. **Avoid using downward pressure on handlebars. If need be, use slight upward pressure to keep the tines from digging too deeply.**

f. **Before contacting hard packed soil at the end of a row, reduce engine speed and lift handlebars to raise tines out of the soil.**

g. **In an emergency, stop tines and wheels by releasing whichever Clutch Lever is engaged. Do not attempt to restrain the tiller.**

15. Do not overload the tiller's capacity by attempting to till too deeply at too fast a rate.

16. Never operate tiller at high transport speeds on hard or slippery surfaces. Look behind and use care when backing up.

17. Do not operate the tiller on a slope that is too steep for safety. When on slopes, slow down and make sure you have good footing. Never permit the tiller to freewheel down slopes.

18. Never allow bystanders near the unit.

19. Only use attachments and accessories that are approved by the tiller manufacturer.

20. Use tiller attachments and accessories when recommended.

21. Never operate the tiller without good visibility or light.

22. Never operate the tiller if you are tired, or under the influence of alcohol, drugs or medication.

23. Operators shall not tamper with the engine-governor settings on the machine; the governor controls the maximum safe operating speed to protect the engine and all moving parts from damage caused by over-speed. Authorized service shall be sought if a problem exists.

24. Do not touch engine parts which may be hot from operation. Let parts cool down sufficiently.

25. The battery on electric start model tillers (if so equipped) contains sulfuric acid. Avoid contact with skin, eyes, or clothing. Keep out of the reach of children.

**Antidote—External Contact:** Flush immediately with lots of water.

**Antidote—Internal:** Drink large quantities of water or milk. Follow with milk of magnesia, beaten eggs or vegetable oil. Call a doctor **immediately**.

**Antidote—Eye Contact:** Flush with water for 15 minutes. **Get prompt medical attention.**

26. Batteries produce explosive gases. Keep sparks, flame, and smoking materials away. Ventilate when charging batteries or when using a battery in an enclosed space. ALWAYS wear safety goggles when working near batteries.

27. Please remember: You can always stop the tines and wheels by releasing the Forward Clutch Control Lever or the Reverse Clutch Control knob (whichever control you have engaged), or by moving the engine switch (located on engine) to the OFF position.

28. To load or unload the tiller, see the instructions in Section 4 of this Manual.

29. Use extreme caution when reversing or pulling the machine towards you.

30. Start engine carefully according to instructions and with feet away from tines.

31. Never pick up or carry a machine while the engine is running.

## MAINTENANCE AND STORAGE

1. Keep the tiller, attachments and accessories in safe working condition.

2. Check all nuts, bolts, and screws at frequent intervals for proper tightness to be sure the equipment is in safe working condition.

3. Never store the tiller with fuel in the fuel tank inside a building where ignition sources are present such as hot water and space heaters, furnaces, clothes dryers, stoves, electric motors, etc. Allow engine to cool before storing in any enclosure.

4. To reduce the chances of a fire hazard, keep the engine free of grass, leaves, or excessive grease.

5. Store gasoline in a cool, well-ventilated area, safely away from any spark- or flame-producing equipment. Store gasoline in an approved container, safely away from the reach of children.

6. Refer to the storage instructions in the Maintenance section of this Manual and in the separate Engine Owner's Manual for instructions if the tiller is to be stored for an extended period.

7. Never perform maintenance while the engine is running or the spark plug wire is connected, except when specifically instructed to do so.

8. If the fuel tank has to be drained, do this outdoors.

## DECALS

For your safety and the safety of others, various safety message decals are on your unit (see Figure 1-2). Keep the decals clean and legible at all times. Contact your local service dealer or the Factory for replacements if any decals are damaged or missing.

Refer to the Parts List in this manual for decal locations, part numbers and ordering instructions.

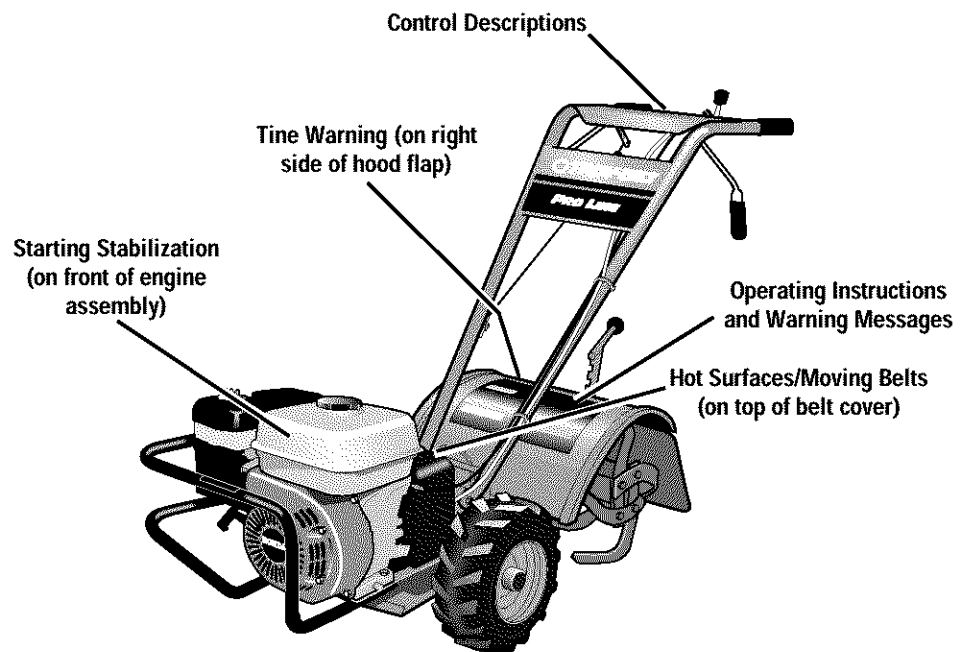
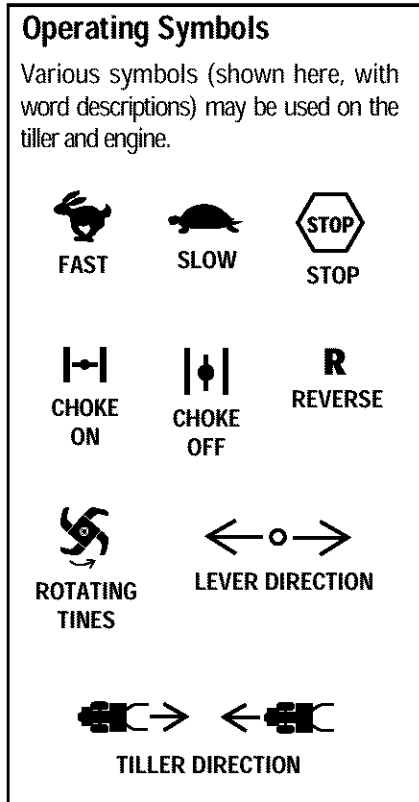

Figure 1-2: Location of safety and operating decals.

### WARNING

#### TO AVOID SERIOUS INJURY:

- READ THE OWNER'S MANUAL.
- KNOW LOCATIONS AND FUNCTIONS OF ALL CONTROLS.
- KEEP ALL SAFETY DEVICES AND SHIELDS IN PLACE AND WORKING.
- NEVER ALLOW CHILDREN OR UNINSTRUCTED ADULTS TO OPERATE TILLER.
- SHUT OFF ENGINE AND DISCONNECT SPARK PLUG WIRE BEFORE MANUALLY UNCLOGGING TINES OR MAKING REPAIRS.
- KEEP BYSTANDERS AWAY FROM MACHINE.
- KEEP AWAY FROM ROTATING PARTS.
- USE EXTREME CAUTION WHEN REVERSING OR PULLING THE MACHINE TOWARDS YOU.

**WARNING**

To prevent personal injury or property damage, do not start the engine until all assembly steps are complete and you have read and understand the safety and operating instructions in this Manual.

**INTRODUCTION**

Carefully follow these assembly steps to correctly prepare your tiller for use. It is recommended that you read this Section in its entirety before beginning assembly.

**INSPECT UNIT**

Inspect the unit and carton for damage immediately after delivery. Contact the carrier (trucking company) if you find or suspect damage. Inform them of the damage and request instructions for filing a claim. To protect your rights, put your claim in writing and mail a copy to the carrier within 15 days after the unit has been delivered. Contact us at the factory if you need assistance in this matter.

**UNPACKING AND ASSEMBLY INSTRUCTIONS****STEP 1: UNPACKING INSTRUCTIONS**

1. Remove any cardboard inserts and packaging material from the carton. Remove any staples from the bottom of the carton and remove the carton.
2. Cut the large, plastic tie strap that secures the transmission tube to the shipping pallet. Leave the handlebars on top of the tiller to avoid damaging any cables.
3. A bag with loose hardware is inside the literature envelope. Check the contents against the following list and Figure 2-1. Contact your local dealer or the factory if any items are missing or damaged.
4. The tiller is heavy. You should not attempt to remove it from the shipping platform until instructed to do so in these "Assembly" steps.

**HARDWARE BAG PARTS LIST**

Fig. Ref.	Qty.	Description
1	2	3/8"-16 x 1" Hex Hd. Screw
2	1	Keyed Washer
3	1	Wheel Gear Lever Knob
4	1	Height Adjustment Flange Screw (See Figure 2-1A)
5	2	3/8" Flat Washer
6	2	#10 Lockwasher
7	2	3/8"-16 Nylock Locknut
8	2	#10-32 x 1/2" Round Hd. Screw
9	1	Cotter Pin (not used)
10	4	Plastic Tie Strap (2 not used)

**Tools/Materials Needed for Assembly**

- (1) 3/8" open-end wrench\*
  - (2) 9/16" open-end wrench\*
  - (1) 7/8" open-end wrench or 8" long adjustable wrench
  - (1) Scissors (to trim plastic ties)
  - (1) Ruler
  - (1) Small board (to tap plastic knob on lever)
  - (1) Tire pressure gauge
  - (1) Clean oil funnel
  - (1) Clean, high-quality motor oil. Refer to the separate Engine Owner's Manual for motor oil specifications and quantity required.
- \* Adjustable wrenches may be used.

**IMPORTANT:** Motor oil must be added to the engine crankcase before the engine is started. Follow the instructions in this "Assembly" Section and in the separate Engine Owner's Manual.

**NOTE:** LEFT and RIGHT sides of the tiller are as viewed from the operator's position behind the handlebars.

**STEP 2: ATTACH HANDLEBARS**

1. Cut the large, plastic cable ties that secure the handlebar ends to the handlebar mounting tabs on the transmission top cover.
2. Gently lift handlebar (do not overstretch attached cable) and place handlebar cross-brace (B, Figure 2-2) in front of curved height adjustment bracket (C).

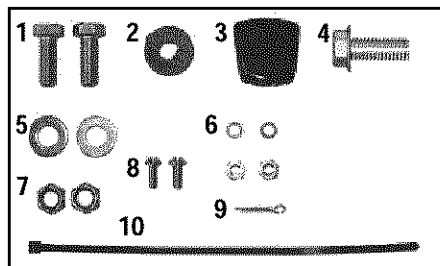

Figure 2-1: Loose hardware (shown in reduced size).

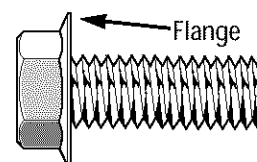

Figure 2-1A: Handlebar height adjustment uses the flange head screw.

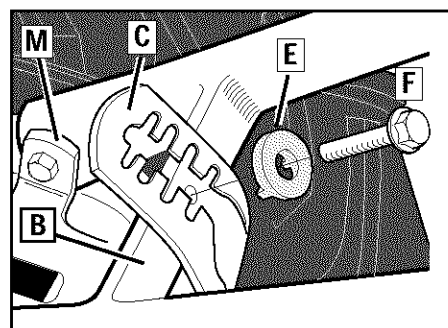

Figure 2-2: Forward clutch control cable not shown for clarity.

3. With forward clutch cable (N, Figure 2-3) on inside of handlebar, position handlebar ends on outside of the two mounting tabs (M, Figure 2-2) on transmission top cover.

4. Loosely attach the handlebars to the mounting tabs with two 3/8"-16 x 1" screws (heads of screws go to inside of tabs), 3/8" flat washers and 3/8"-16 locknuts (O, Figure 2-3).

5. Move the handlebars up or down to align the threaded hole in the cross-brace with one of the four slots in the curved height adjustment bracket. Place the keyed washer (E, Figure 2-2) on the flange head height adjustment screw (F) with the raised keys (edges) of the washer facing down.

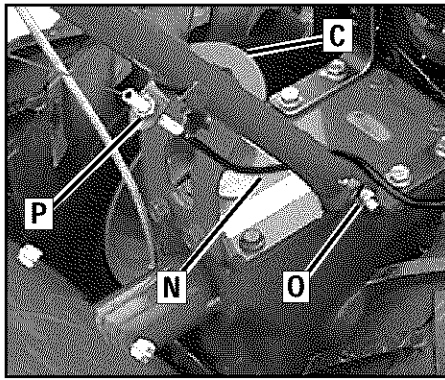

Figure 2-3: Attach handlebars.

6. Thread the height adjustment screw (F, Figure 2-2) into the hole in the handlebar cross-brace, making sure that the raised keys on the washer fit into the slot on the height adjustment bracket. Tighten the height adjustment screw securely. Next, securely tighten the two screws and nuts in the ends of the handlebar (M, Figure 2-2).

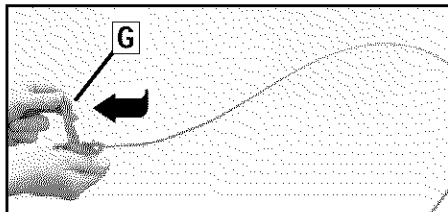

Figure 2-4: Carefully unwrap Wheel Gear Lever and move lever to DISENGAGE.

7. To remove the tiller from its shipping platform, first carefully unwrap the wheel gear cable (with attached lever - see Figure 2-4) from around the chassis. Move the Wheel Gear Lever (G) to the DISENGAGE position--this allows the wheels to rotate freely. Use the handlebars to roll the tiller off the platform.

NOTE: The Wheel Gear Lever will be installed later in this procedure.

**IMPORTANT:** Use the DISENGAGE position only when the engine is not running. Before starting the engine, the Wheel Gear Lever must be placed in the ENGAGE position (see Section 3 for details).

### STEP 3: ATTACH REVERSE CLUTCH CONTROL CABLE

1. Carefully unwrap the reverse clutch control cable (H, Figure 2-5) from its shipping position and route it up along the inside edge of the left side handlebar. A knob and large hex nut (I) is installed on the cable.

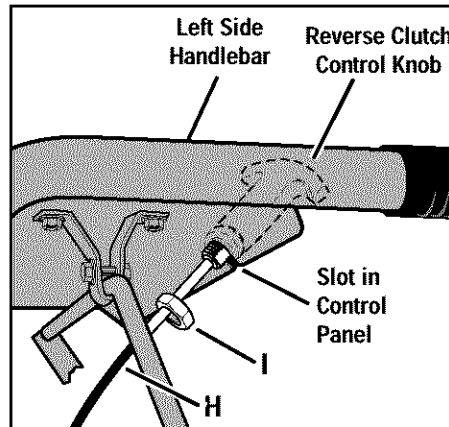

Figure 2-5: Attach reverse clutch control assembly to slotted hole in handlebar panel.

2. Insert the cable into the slot in the control panel and fit the threaded assembly into the hole in the slot (see Figure 2-5). Be sure that the flat side of the threaded assembly is aligned with the flat side of the hole. Slide the hex nut (I) up the cable and tighten it securely.

3. Test the function of the reverse clutch control cable by pulling the knob out and releasing it. The knob should return to its neutral position against the tapered bushing when it is released. If it doesn't, contact your local dealer or the factory for technical assistance.

### STEP 4: ATTACH FORWARD CLUTCH CONTROL CABLE

1. Remove any fasteners (rubber bands, tape, etc.) that may secure the Forward Clutch Control levers (J, Figure 2-6) to the handlebar.

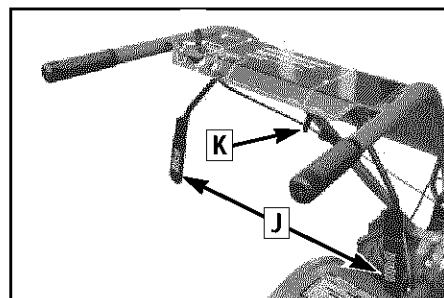

Figure 2-6: Forward Clutch Control levers (J). Forward clutch control linkage (K).

2. The forward clutch control cable (with attached spring) is hanging loosely near the right-side wheel. Being careful not to kink or stretch the cable, insert the z-connector (L, Figure 2-7 - end of the spring) into the hole at the end of the forward clutch control linkage (K, Figure 2-6).

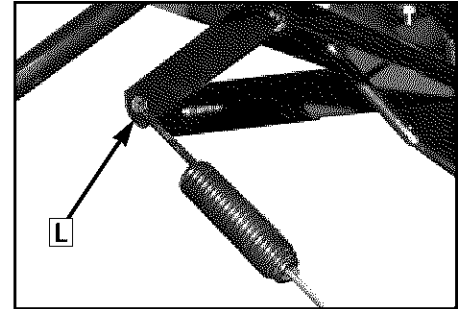

Figure 2-7

3. Attach the cable adjuster (A, Figure 2-8) to the bracket on the right-side handlebar. Use two 1/2" wrenches to loosen the two jam nuts (B) just enough to slide the cable adjuster onto the bracket. Then hand tighten the jam nuts.

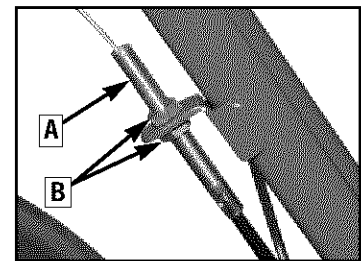

Figure 2-8

### ⚠ CAUTION

Incorrect cable adjustment could cause the wheels and tines to rotate unexpectedly. Follow adjustment procedures carefully. Failure to do so could result in personal injury or property damage.

4. Check for correct spring/cable tension as instructed in Section 5, *Checking and Adjusting Forward Clutch Belt Tension*.

5. When tension is correct, tighten the two jam nuts (B, Figure 2-8) securely.

## STEP 5: CHECK TRANSMISSION GEAR OIL LEVEL

The transmission was filled with gear oil at the factory. However, be sure to check the oil level at this time to make certain it is correct.

**IMPORTANT:** Do not operate the tiller if the gear oil level is low. Doing so will result in severe damage to the transmission components.

1. With the tiller on level ground, pull the Depth Regulator Lever (L, Figure 2-9) back and then slide it to the second notch from the top. NOTE: If the lever does not move, lift the tine hood flap and look for a plastic tie securing the lever in place. Cut and remove the tie.

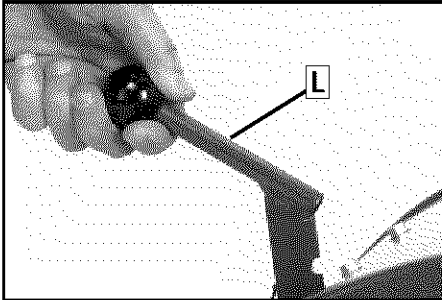

Figure 2-9: Put lever in second notch.

2. Remove the oil level check plug (M, Figure 2-10) on the left-side of the transmission. (Due to dried paint on the plug threads, it may require some force to remove the plug the first time.) The gear oil level is correct if oil starts to flow out of the hole as the plug is removed. If so, securely reinstall the plug.

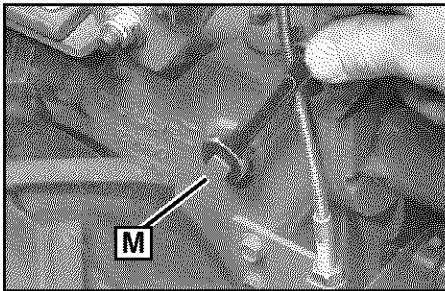

Figure 2-10: Gear oil level check plug.

3. If oil does not flow from the check hole, add oil as follows:

NOTE: Do not use automatic transmission fluid or motor oil in the transmission.

- Clean area around the fill hole (N, Figure 2-11) and unscrew gear oil fill plug.
- If adding only a few ounces of gear oil, use API rated GL-4 or GL-5 gear oil

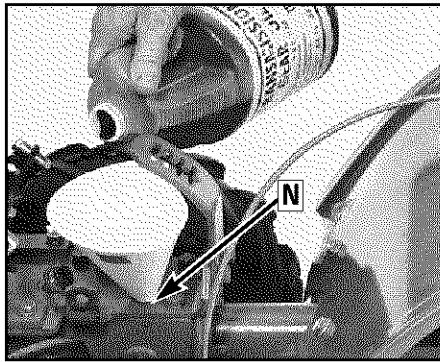

Figure 2-11: Adding gear oil.

having a viscosity of SAE 140, SAE 85W-140 or SAE 80W-90. If refilling an empty transmission, use only GL-4 gear oil having a viscosity of SAE 85W-140 or SAE 140.

- Using a clean funnel, slowly add gear oil until it flows from the gear oil level check hole (N, Figure 2-11).
- Reinstall and tighten securely the gear oil fill plug (M, Figure 2-10).

## STEP 6: ADD MOTOR OIL TO ENGINE

The tiller is shipped *without* oil in the engine.

**IMPORTANT:** Do not start the engine without first adding motor oil. Severe engine damage will result if the engine is run without oil.

- Refer to the separate Engine Owner's Manual for motor oil specifications and capacities.
- With the unit on level ground, move the Depth Regulator Lever (L, Figure 2-9) up or down until the engine is level.
- Add motor oil as described in the Engine Owner's Manual.
- Move the Depth Regulator Lever all the way down until the highest notch is engaged. This places the tines in the "travel" position.

## STEP 7: ATTACH WHEEL GEAR LEVER

- Insert the Wheel Gear Lever (P, Figure 2-12) up through the control panel that is labeled "WHEEL GEAR."
- Insert two #10-32 x 1/2" round head screws down through the "+" marks on the control panel decal and securely attach the wheel gear mounting bracket using two #10 lockwashers and #10-32 nuts.
- Using a board, tap the Wheel Gear Lever knob securely onto the lever.

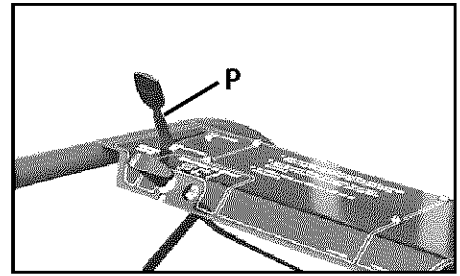

Figure 2-12: Attach Wheel Gear Lever.

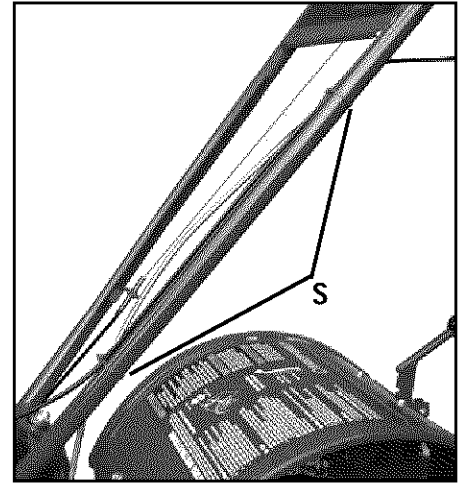

Figure 2-13: Attach wheel gear cable and reverse clutch cable with cable ties (S).

4. Secure the wheel gear cable and the reverse clutch control cable to the left-side handlebar with two plastic ties (S, Figure 2-13) located about two feet apart. Snip off any excess tie length with scissors.

## STEP 8: CHECK AIR PRESSURE IN TIRES

Use a tire pressure gauge to check the air pressure in both tires. Deflate or inflate both tires equally to 15-to-20 PSI (pounds per square inch). Be sure that both tires are inflated equally or the unit will pull to one side.

## STEP 9: CHECK HARDWARE FOR TIGHTNESS

Inspect the hardware on the unit and tighten any loose screws, bolts and nuts.

**This completes the assembly steps. Be sure to read the rest of this Manual before you operate your tiller.**



**⚠ WARNING**

Before operating your machine, carefully read and understand all safety, controls and operating instructions in this Manual, in the separate Engine Owner's Manual, and on the decals on the machine.

Failure to follow these instructions can result in serious personal injury.

**INTRODUCTION**

This section describes the location and function of the controls on your tiller. Refer to Section 4: *Operation* for detailed operating instructions.

Practice using these controls, with the engine shut off, until you understand the operation of the controls and feel confident with each of them.

**IMPORTANT:** Refer to the separate engine manufacturer's Engine Owner's Manual for information about the controls on the engine.

**WHEEL GEAR LEVER**

This lever (A, Figure 3-1) has two positions: ENGAGE and DISENGAGE.

In the ENGAGE position, the wheels will start turning when either the Forward Clutch Control or Reverse Clutch Control is engaged (the tines will also start turning when either is engaged).

The DISENGAGE (freewheel) position places the wheels in the freewheeling mode to allow the unit to be moved without the engine running. Use the DISENGAGE position only when the engine is not running. See "DANGER" statement that follows.

To shift to ENGAGE, gently (do not force) move the lever forward while also rolling the tiller a few inches forward or backward. Moving the tiller helps to align the shift mechanism with the transmission wheel drive gears.

To shift to DISENGAGE, move the lever rearward, without rolling the tiller. The wheels will roll freely when the lever is properly set into the DISENGAGE position.

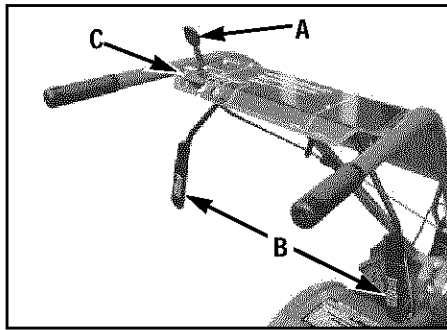

Figure 3-1: Controls located on handlebar.

**⚠ DANGER**

Never place the Wheel Gear Lever in DISENGAGE (Freewheel) when the engine is running.

Having the Wheel Gear Lever in DISENGAGE and then engaging the tines/wheels with either Forward Clutch Control Lever or Reverse Clutch Control could allow the tines to propel the tiller rapidly forward or backward.

Failure to follow this instruction could result in personal injury or property damage.

**⚠ WARNING**

Never engage the wheels and tines with Forward Clutch Control Levers or Reverse Clutch Control unless the Wheel Gear Lever is in ENGAGE.

Engaging Forward Clutch Control Levers or Reverse Clutch Control when the wheels are not engaged could allow the tines to rapidly propel the tiller forward or backward.

Failure to follow this warning could result in personal injury or property damage.

**FORWARD CLUTCH CONTROL LEVERS**

The two interconnected levers (B, Figure 3-1) control the engagement of forward drive to the wheels and tines.

**To Operate the Forward Clutch Control:**

1. Before engaging the Forward Clutch Control Levers, put the Wheel Gear Lever in the ENGAGE position (see "WARNING" above).

2. Lift and hold one or both of the levers against the handlebar grips to engage the wheels and tines.

3. Release BOTH levers to disengage (stop) the wheels and tines. All forward motion will stop (the engine will continue to run).

**REVERSE CLUTCH CONTROL**

The Reverse Clutch Control (C, Figure 3-1) controls the engagement of reverse drive to the wheels and tines.

The reversing feature is used for maneuvering the tiller only – never engage the tines in the ground while reversing.

**To Operate the Reverse Clutch Control:**

1. Put the Wheel Gear Lever in the ENGAGE position (see previous "WARNING" statement).
2. Stop all tiller motion by releasing the Forward Clutch Control Levers.
3. Lift up the handlebars until the tines clear the ground, look behind you to avoid any obstacles, and then pull the Reverse Clutch Control knob out. The tines and wheels will rotate in a reverse direction.
4. Release the Reverse Clutch Control knob to disengage (stop) the wheels and tines. All reverse motion will stop (the engine will continue to run).

**⚠ WARNING**

- Use extreme caution when reversing or pulling the machine towards you. Look behind to avoid obstacles.

- Never attempt to till in reverse.

Failure to follow this warning could result in personal injury or property damage.

**DEPTH REGULATOR LEVER**

This lever (D, Figure 3-2) controls the tilling depth of the tines. Pull the lever straight back and slide it up or down to engage the notched height settings.

The highest notch (lever all the way down) raises the tines approximately 1-1/2 inches off the ground. This "travel" position allows the tiller to be moved without the tines digging into the ground.

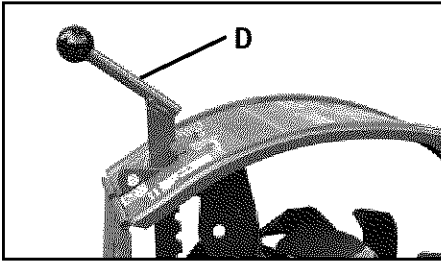

Figure 3-2: Depth Regulator Lever.

Moving the lever up increases the tilling depth. The lowest notch allows a tilling depth of approximately six to eight inches, depending on soil conditions.

**For best results, always begin tilling at a very shallow depth setting and gradually increase the tilling depth.**

Complete details on using the Depth Regulator are found in Section 4 of this manual.

### **⚠ WARNING**

- Do not attempt to till too deeply too quickly. Gradually work down to deeper tilling depths.
- Place the Depth Regulator Lever in the "travel" position before starting the engine. This position prevents the tines from touching the ground until you are ready to begin tilling.

**Failure to follow this warning could result in personal injury or property damage.**

### HANDLEBAR HEIGHT ADJUSTMENT

The handlebar height is adjustable to four different settings. When setting the height, keep in mind that the handlebars will be lower when the tines are engaged in the soil.

#### To Adjust the Handlebar Height:

1. Stop the engine, wait for all parts to stop moving and then disconnect the spark plug wire. Remove the ignition key on electric start models.
2. Loosen the two screws at the lower ends of the handlebar.
3. Loosen the height adjustment flange screw (F, Figure 3-3) and pull the keyed washer (E) free of the slots in the curved height adjustment bracket.

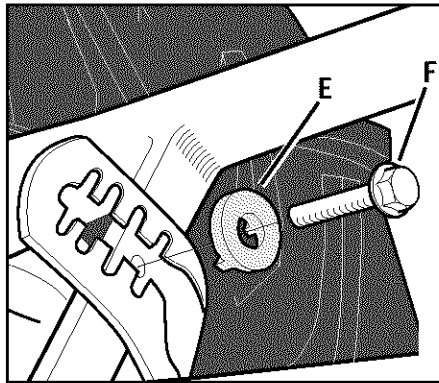

Figure 3-3

4. Move the handlebars to the new slot setting and insert the raised keys on the keyed washer into the slot. Tighten the height adjustment flange screw securely.
5. Retighten the two screws at the ends of the handlebar.

### ENGINE CONTROLS

Refer to the engine manufacturer's Engine Owner's Manual (included in the tiller literature package) to identify the controls on your engine.

**IMPORTANT:** The control for stopping the engine is located on the engine.

#### **SPECIAL NOTICE REGARDING "MOTOR OIL ALERT SYSTEM"**

The engine on your tiller *is not* equipped with a functioning "Oil Alert System" and you should ignore any references in your Engine Owner's Manual regarding this feature.

The "Oil Alert System" is not practical for use with your tiller because the engine is frequently operated in non-level applications that would provide false readings to the system's oil level sensor. These false readings would result in frequent, and unnecessary, engine shut downs.

You can easily protect your engine from damage caused by insufficient oil in the crankcase by simply remembering to do the following:

- Check the motor oil level before starting the engine.
- Check the motor oil level after every five (5) hours of continuous operation.

**⚠ WARNING**

Before operating your machine, carefully read and understand all safety (Section 1), controls (Section 3) and operating instructions (Section 4) in this Manual, in the separate Engine Owner's Manual, and on the decals on the machine.

Failure to follow these instructions can result in serious personal injury.

**INTRODUCTION**

Read this section of the manual thoroughly before you start the engine. Then, take the time to familiarize yourself with the basic operation of the tiller before using it in the garden. Find an open, level area and practice using the tiller controls without the tines engaging the soil (put tines in "travel" setting). Only after you've become completely familiar with the tiller should you begin using it in the garden.

**BREAK-IN OPERATION**

Perform the following maintenance during the first 2 (two) hours of new operation (see Section 5 of this manual and the Maintenance section of the Engine Owner's Manual).

1. Change motor oil.
2. Check for loose or missing hardware on unit. Tighten or replace as needed.
3. Check transmission gear oil level.
4. Check tension on forward clutch belt.

**STARTING/STOPPING ENGINE****PRE-START CHECKLIST**

Do the following before starting the engine:

1. Read the *Safety and Features and Controls* sections in this manual. Read the separate Engine Owner's Manual provided by the engine manufacturer.
2. Check unit for loose or missing hardware. Service as required.
3. Check motor oil level. See Engine Owner's Manual.
4. Check that all safety guards and covers are in place.
5. Check air cleaner and engine cooling system. See Engine Owner's Manual.

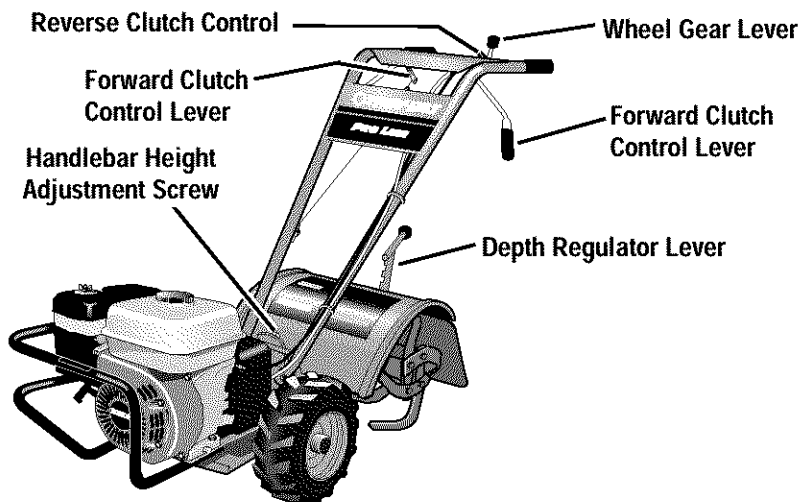

Figure 4-1

**⚠ DANGER**

**GASOLINE IS HIGHLY FLAMMABLE AND ITS VAPORS ARE EXPLOSIVE.**

Follow gasoline safety rules in this manual (see Section 1) and in the separate Engine Owner's Manual.

Failure to follow gasoline safety instructions can result in serious personal injury and property damage.

6. Fill the fuel tank with gasoline according to the directions in the separate Engine Owner's Manual. Follow all instructions and safety rules carefully.
7. Attach spark plug wire to spark plug.

**⚠ CAUTION**

To help prevent serious personal injury or damage to equipment:

- Before starting engine, put Wheel Gear Lever in ENGAGE position.
- Before starting engine, put Forward Clutch Control Levers and Reverse Clutch Control in neutral (disengaged) positions by releasing controls.
- Never run engine indoors or in enclosed, poorly ventilated area. Engine exhaust contains carbon monoxide, an odorless and deadly gas.
- Avoid engine muffler and nearby areas. Temperatures in these areas may exceed 150°F.

**STARTING THE ENGINE**

The following steps describe how to start and stop the engine.

Do not engage the tines or wheels until you have read all of the operating instructions in this section, the safety rules in Section 1: *Safety*, and the controls information in Section 3: *Features and Controls*.

1. Complete the *Pre-Start Checklist* in this section.

**⚠ WARNING**

**Keep away from rotating tines. Rotating tines will cause injury.**

2. Put the Wheel Gear Lever (Figure 4-1) in the ENGAGE position.
3. Put the Depth Regulator Lever in the "travel" position (lever all the way down) so that the tines are clear of the ground.
4. Release all controls on the tiller.
5. Put the engine switch in the ON position, as instructed in the separate Engine Owner's Manual.
6. On engines equipped with a fuel valve, move valve to the ON position as instructed in the separate Engine Owner's Manual.
7. Choke or prime engine as instructed in the separate Engine Owner's Manual.
8. Put the throttle lever in the start position as instructed in the separate Engine Owner's Manual.
9. Operate the recoil starter:
  - (a) Place one hand on fuel tank to stabilize unit when you pull the starter handle.

(b) Use the recoil starter rope to start the engine as instructed in the separate Engine Owner's Manual. When the engine starts, gradually move the choke lever (if used) to the OPEN, CHOKE OFF or RUN position.

(c) Put the engine throttle lever in the FAST setting when tilling.

## STOPPING THE ENGINE

1. To stop the wheels and tines, release the Forward Clutch Control Levers or the Reverse Clutch Control knob (whichever control you have engaged).

2. To stop the engine, move the engine switch to the OFF position (if time allows, first move the engine throttle lever to the SLOW position).

3. Turn the fuel valve (if so equipped) to the OFF position.

## OPERATING THE TILLER

### ⚠ WARNING

Before tilling, contact your telephone or utilities company and inquire if underground equipment or lines are on your property.

The following pages provide guidelines to using your tiller effectively and safely in various gardening applications. Be sure to read *Tilling Tips & Techniques* in this section before you actually put the tines into the soil.

NOTE: This is a traditional "standard rotating tine" tiller with forward rotating tines. It operates completely differently from CRT (Counter Rotating Tines) tillers or from low-cost front tine tillers.

1. Follow the *Pre-Start Checklist* on the previous page. Be sure that the Wheel Gear Lever is in the ENGAGE position.

2. Put the Depth Regulator Lever in the "travel" position (lever all the way down) so that the tines clear the ground. Use this position when practicing with or transporting the tiller. When you are ready to begin tilling, move the Depth Regulator Lever to the desired depth setting (see *Tilling Tips & Techniques*).

3. Start the engine and allow it to warm up. When warm, put throttle control in FAST speed setting.

4. FORWARD MOTION of the wheels and tines:

(a) Pull up and hold one or both of the Forward Clutch Control Levers against the handlebars. To stop the wheels and tines, release both levers.

### ⚠ WARNING

**Do not push down on the handlebars to make the tiller till more deeply. This prevents the wheels from holding tiller back and can allow the tines to rapidly propel the tiller forward, which could result in loss of control, property damage, or personal injury.**

(b) As the tiller moves forward, relax and let the wheels pull the unit along while the tines dig. Walk behind and a little to one side of the tiller. Use a light but secure grip with one hand on the handlebars, but keep your arm loose. See Figure 4-2. Let the tiller move ahead at its own pace. Do not push down on the handlebars to try and force the tiller to dig deeper – this takes weight off the wheels, reduces traction, and causes the tines to try and propel the tiller.



Figure 4-2: Guiding the tiller with one hand.

5. REVERSE MOTION of the wheels and tines:

(a) Look behind and exercise caution when operating in reverse. **Do not till while in reverse.**



Figure 4-3: Reversing the tiller.

(b) Stop all forward motion before reversing. Lift the handlebars with one hand until the tines are off the ground and then pull the Reverse Clutch Control knob out (Figure 4-3). To stop reverse motion, let go of the Reverse Clutch Control knob.

6. To turn the tiller around:

(a) Practice turning in a level, open area. Be very careful to keep your feet and legs away from the tines.

(b) To start a turn, reduce the engine speed and then lift the handlebars until the engine and tines are balanced over the wheels (Figure 4-4).



Figure 4-4: Find balance point before turning.

(c) With tiller balanced, push sideways on handlebar to move tiller in direction of the turn (Figure 4-5). After completing the turn, slowly lower the tines to the soil and increase the engine speed.

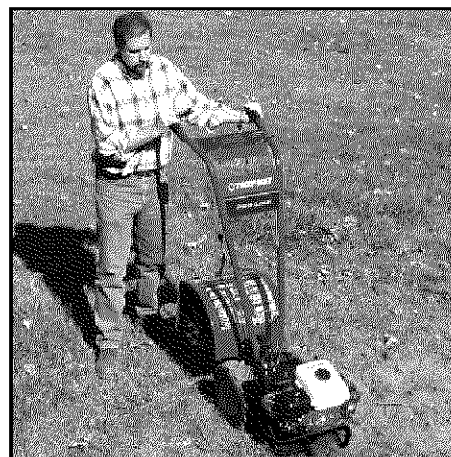

Figure 4-5: Push handlebars sideways to turn tiller.

## STOPPING THE TILLER AND ENGINE

1. To stop the wheels and tines, release the Forward Clutch Control Levers or the Reverse Clutch Control knob (whichever is engaged).

2. To stop the engine, move the engine switch to the OFF position.

## TILLING TIPS & TECHNIQUES

### Tilling Depths

- Avoid the temptation to push down on the handlebars in an attempt to force the tiller to dig deeper. Doing so takes the weight off the powered wheels, causing them to lose traction. Without the wheels to help hold the tiller back, the tines will attempt to propel the tiller – often causing the tiller to skip rapidly across the ground. (Sometimes, slight downward pressure on the handlebars will help get through a particularly tough section of sod or unbroken ground, but in most cases this won't be necessary.)
- When cultivating (breaking up surface soil around plants to destroy weeds, see Figure 4-9), adjust the tines to dig only 1" to 2" deep. Using shallow tilling depths helps prevent injury to plants whose roots often grow close to the surface. If needed, lift up on the handlebars slightly to prevent the tines from digging too deeply. (Cultivating on a regular basis eliminates weeds, and loosens and aerates the soil for better moisture absorption and faster plant growth.)
- Avoid trying to dig too deeply too quickly, especially when busting sod or when tilling soil that hasn't been tilled for some time. Use shallow depth regulator settings (only an inch or two deep) for the first passes through the garden area. With each succeeding pass, adjust the depth regulator to dig another inch or two deeper. (Watering the garden area a few days prior to tilling will make tilling easier, as will letting the newly worked soil set for a day or two before making a final, deep tilling pass.)

### Choosing Correct Wheel and Tine Speeds

With experience, you will find the "just right" tilling depth and tilling speed combination that is best for your garden.

Set the engine throttle lever at a speed to give the engine adequate power and yet allow it to operate at the slowest possible speed...at least until you have achieved the maximum tilling depth you desire. Faster engine speeds may be desirable when making final passes through the seedbed or when cultivating. Selection of the correct engine speed, in relation to the tilling depth, will ensure a sufficient power level to do the job without causing the engine to labor.

### Let the Tiller Do the Work

While tilling, relax and let the wheels pull the tiller along while the tines do the digging. Walk on the side that is not yet finished (to avoid making footprints in the freshly tilled soil) and lightly, but securely grip the handlebar with just one hand.

### Avoid Making Footprints

Whenever possible, walk on the untilled side of the unit to avoid making footprints in your freshly tilled or cultivated soil. Footprints cause soil compaction that can hamper root penetration and contribute to soil erosion. They can also "plant" unwanted weed seeds back into the freshly tilled ground.

### Avoid Tilling Soggy, Wet Soil

Tilling wet soil often results in large, hard clumps of soil that can interfere with planting. If time permits, wait a day or two after heavy rains to allow the soil to dry before tilling. Test soil by squeezing it into a ball. If it compresses too easily, it is too wet to till.

### Preparing Seedbeds

- When preparing a seedbed, go over the same path twice in the first row, then overlap one-half the tiller width on the rest of the passes (see Figure 4-6). When finished in one direction, make a second pass at a right angle, as shown in Figure 4-7. Overlap each pass for best results (in very hard ground, it may take three or four passes to thoroughly pulverize the soil.)

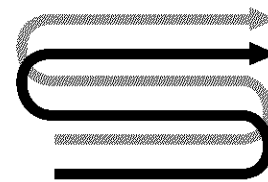

Figure 4-6

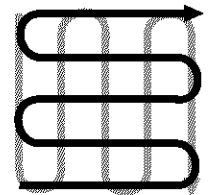

Figure 4-7

- If the garden size will not permit lengthwise and then crosswise tilling, then overlap the first passes by one-half a tiller width, followed by successive passes at one-quarter width (see Figure 4-8).



Figure 4-8

### Cultivating

With planning, you can allow enough room between rows to cultivate (see Figure 4-9). Leave room for the hood width, plus enough extra room for future plant growth.

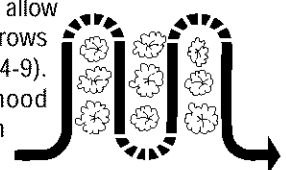

Figure 4-9

## TILLING TIPS & TECHNIQUES (cont.)

### Power Composting

Power composting simply means tilling under and burying in the soil all manner of organic matter such as crop residues, leaves, grass clippings and cover crops. This material will decompose during the non-growing season and add important natural nutrients to the soil.

The first place to begin is with crop residues such as leftover vines, stalks, stems and roots. Power compost these crop residues as soon as they finish bearing. The sooner this is done, the better, as tender green matter is easier to till under. Use the deepest depth regulator setting possible without causing the engine to labor or the tiller to jump ahead.

Standing cornstalks of reasonable height can be power composted. Pushing over (but not uprooting) cornstalks will often make it easier to chop up the stalks. Keep the tines clear of excessive tangling by "fishtailing" or frequently using reverse. Make several passes, then return a few days later to finish off any remaining stubble.

After tilling under crop residues, add more organic matter such as leaves, grass clippings and even kitchen scraps. When tilled into the soil, this organic matter will decompose and add even more important nutrients to the soil.

After power composting, you may want to plant a "green manure" cover crop to protect the soil during the off-season. You simply grow a crop of clover, alfalfa, buckwheat, peas, beans, rye grass, grain, or kale and then till it into the soil prior to the planting season.

### WARNING

When power composting, do not keep the Depth Regulator Lever at a deep setting if the tiller jumps or bucks.

If jumping or bucking occurs, move the Depth Regulator Lever down to a shallow setting and then slowly increase the tilling depth on later passes.

Failure to follow this warning could result in personal injury.

### Tilling On Slopes

#### Read the following recommendations before tilling on slopes:

If you must garden on a moderate slope, please follow two very important guidelines:

1. Till only on moderate slopes, never on steep ground where footing is difficult (review safety rules in Section 1: *Safety* of this manual).
2. We recommend tilling up and down slopes rather than terracing. Tilling vertically on a slope allows maximum planting area and also leaves room for cultivating.

**IMPORTANT:** When tilling on slopes, be sure the correct oil level is maintained in the engine (check every one-half hour of operation). The incline of the slope will cause the oil to slant away from its normal level and this can starve engine parts of required lubrication. Keep the motor oil level at the full point at all times!

#### Tilling Up and Down Slopes (Vertical Tilling)

- To keep soil erosion to a minimum, be sure to add enough organic matter to the soil so that it has good moisture-holding texture and try to avoid leaving footprints or wheel marks.
- When tilling vertically, try to make the first pass uphill as the tiller digs more deeply going uphill than it does downhill. In soft soil or weeds, you may have to lift the handlebars slightly while going uphill. When going downhill, overlap the first pass by about one-half the width of the tiller.

#### Terrace Gardening

- When a slope is too steep or too short for vertical tilling, it may be necessary to till across the slope and create terraced rows. Terraces are rows that are cut into the side of a slope, creating a narrow, but flat area on which to plant.
- On a long slope, you can make several terraces, one below the other.
- Terraces should be only 2-to-3 feet wide. Digging too far into the side of the slope will expose poor subsoil that is unproductive for plants.

### WARNING

Do not operate the tiller on a slope too steep for safety. When on slopes, slow down and make sure you have good footing. Never permit the tiller to free-wheel down slopes. Failure to follow this warning could result in personal injury.

#### Tilling Across Slopes Without Using Terraces (Horizontal Tilling)

- If vertical or terrace gardening aren't practical for you, then you can till laterally across a slope. We don't recommend this method as it can create unsure footing and invites soil erosion.
- As in terrace gardening, start at the top of the slope and overlap the first pass by half the width of the tiller. For added stability of the tiller, always keep the uphill wheel in the soft, newly tilled soil.

## TILLING TIPS & TECHNIQUES (cont.)

### Terrace Gardening (continued)

- To create a terrace, start at the top of the slope and work down. Go back and forth across the first row as shown in Figure 4-10.
- Each succeeding lower terrace is started by walking below the terrace you're preparing. For added stability of the tiller, always keep the uphill wheel in the soft, newly tilled soil. Do not till the last 12" or more of the downhill outside edge of each terrace. This untilled strip helps prevent the terraces from breaking apart and washing downhill. It also provides a walking path between rows.

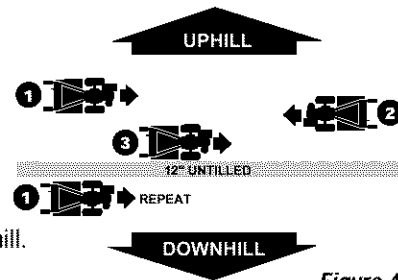

Figure 4-10

### Clearing the Tines

The tines have a self-clearing action which eliminates most tangling of debris in the tines. However, occasionally dry grass, stringy stalks or tough vines may become tangled. Follow these procedures to help avoid tangling and to clean the tines, if necessary.

- To reduce tangling, set the depth regulator deep enough to get maximum "chopping" action as the tines chop the material against the ground. Also, try to till under crop residues or cover crops while they are green, moist and tender.
- While power composting, try swaying the handlebars from side to side (about 6" to 12"). This "fishtailing" action often clears the tines of debris.
- If tangling occurs, lift the tines out of the soil and run the tiller in reverse (if unit is equipped with powered reverse) for a few feet. This reversing action should unwind a good deal of debris.

- It may be necessary to remove the debris by hand (a pocket knife will help you to cut away the material). Be sure to stop the engine and disconnect the spark plug wire before clearing the tines by hand.

### ⚠ WARNING

**Before clearing the tines by hand, stop the engine, allow all moving parts to stop and disconnect the spark plug wire. Remove the ignition key on electric start models.**

**Failure to follow this warning could result in personal injury.**

## LOADING AND UNLOADING THE TILLER

### ⚠ WARNING

**Loading and unloading the tiller into a vehicle is potentially hazardous and we don't recommend doing so unless absolutely necessary, as this could result in personal injury or property damage.**

**However, if you must load or unload the tiller, follow the guidelines given next.**

- Before loading or unloading, stop the engine, wait for all parts to stop moving, disconnect the spark plug wire and let the engine and muffler cool. Remove the ignition key on electric start models.
- The tiller is too heavy (over 170 lbs.) and bulky to lift safely by one person. Two or more people should share the load.
- Use sturdy ramps and manually (engine shut off) roll the tiller into and out of the vehicle. Two or more people are needed to do this.
- Ramps must be strong enough to support the combined weight of the tiller and any handlers. The ramps should provide good traction to prevent slipping; they should have side rails to guide the tiller along the ramps; and they should have a locking device to secure them to the vehicle.
- The handlers should wear sturdy footwear that will help to prevent slipping.
- Position the loading vehicle so that the ramp angle is as flat as possible (the less incline to the ramp, the better). Turn the vehicle's engine off and apply its parking brake.
- When going up ramps, stand in the normal operating position and push the tiller ahead of you. Have a person at each side to turn the wheels.
- When going down ramps, walk backward with the tiller following you. Keep alert for any obstacles behind you. Position a person at each wheel to control the speed of the tiller. Never go down ramps tiller-first, as the tiller could tip forward.
- Place wooden blocks on the downhill side of the wheels if you need to stop the tiller from rolling down the ramp. Also, use the blocks to temporarily keep the tiller in place on the ramps (if necessary), and to chock the wheels in place after the tiller is in the vehicle.
- After loading the tiller, prevent it from rolling by engaging the wheels (put Wheel Gear Lever in ENGAGE). Chock the wheels with blocks and securely tie the tiller down.



**WARNING**

Before inspecting, cleaning or servicing the machine, shut off engine, wait for all moving parts to come to a complete stop, disconnect spark plug wire and move wire away from spark plug. Remove ignition key on electric start models.

Failure to follow these instructions can result in serious personal injury or property damage.

**MAINTENANCE SCHEDULE**

PROCEDURE	NOTES
Check motor oil level	2, 3
Clean engine	2, 7
Check clutch belt tension	1, 4
Check nuts and screws	1, 4
Change motor oil	1, 4, 6
Lubricate tiller	4
Service foam pre-cleaner air filter (if so equipped)	7
Service paper air filter (if so equipped)	7
Check gear oil level in transmission	1, 5
Check tines for wear	5
Check air pressure in tires	5
Service spark plug	7

**NOTES**

- 1 - After first 2 hours of break-in operation.
- 2 - Before each use.
- 3 - Every 5 operating hours.
- 4 - Every 10 operating hours.
- 5 - Every 30 operating hours.
- 6 - More frequently in dusty or dirty conditions.
- 7 - See Engine Owner's Manual for service recommendations.
- 8 - Whichever time interval occurs first.

**TILLER LUBRICATION**

Proper lubrication of the tiller is an essential part of your maintenance program. After every 10 operating hours, oil or grease the lubrication points shown in Figure 5-1, as described below.

Use general purpose lubricating oil (#30 weight motor oil is suitable) and a general purpose grease (grease that has a metal lubricant is preferred, if available).

- Remove wheels and clean wheel shaft (A, Figure 5-1). Apply a thin coating of grease to shaft before reinstalling wheels.
- Grease back, front and sides of Depth Regulator Lever (B, Figure 5-1).

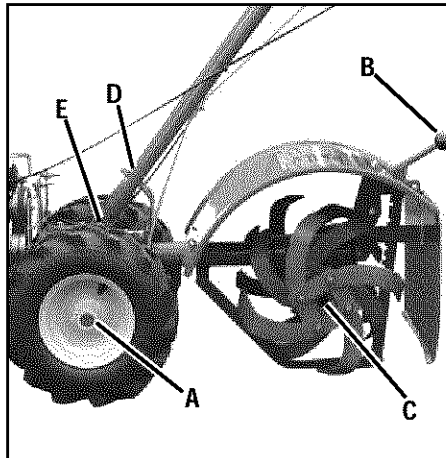

Figure 5-1

- Remove tines and clean tine shafts (C, Figure 5-1). Inspect tines for rust, rough spots or burrs (especially around holes). File or sand smooth and coat ends of shaft with grease.
- Oil threads on handlebar height adjustment flange screw (D, Figure 5-1).
- Oil threads on handlebar attaching screws (E, Figure 5-1).

**CHECK HARDWARE**

Check unit for loose/missing hardware after every 10 operating hours. Loose or missing hardware can lead to equipment failure, poor performance, or oil leaks.

Be sure to check the three end cap mounting screws located at the rear of the transmission (Figure 5-2). Lift the tine flap to service those screws.

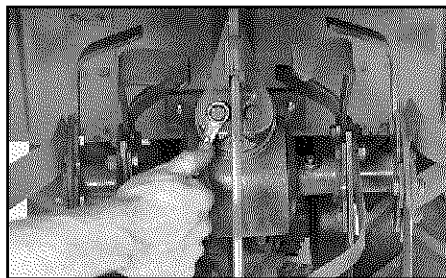

Figure 5-2

**CHECK TIRE PRESSURE**

Check air pressure in both tires. Deflate or inflate both tires evenly to 15-to-20 PSI (pounds per square inch). Be sure that both tires have same air pressure or unit will pull to one side.

**CHECK FOR OIL LEAKS**

Before each use, check tiller for signs of oil leakage—usually a dirty, oily accumulation either on unit or on floor where it has been parked.

A little seepage around a cover or oil seal is usually not cause for alarm. However, if oil drips overnight, then immediate attention is needed—ignoring a leak can result in severe transmission damage.

If a cover leaks, try tightening any loose screws or bolts. If fasteners are tight, a new gasket or oil seal may be needed. If leakage occurs around a shaft and oil seal, the oil seal probably needs replacement. See an authorized dealer or contact the factory for service or advice.

**IMPORTANT:** Never operate tiller if transmission is low on oil. Check oil level after every 30 hours of operation and whenever there is any oil leakage.

**TRANSMISSION GEAR OIL SERVICE****Gear Oil Specifications**

For small top-offs: Use SAE 140, SAE 85W-140, or SAE 80W-90 gear oil with an API rating of either GL-4 or GL-5.

For full replacement: Use SAE 140 or SAE 85W-140 gear oil with API rating of GL-4 (do not use GL-5). Check transmission gear oil level after every 30 hours of operation or whenever an oil leak appears. Operating the tiller when transmission is low on oil can result in severe damage.

**A. To Check Transmission Gear Oil Level:**

1. Check gear oil level when transmission is cool. Gear oil expands when warm and will result in an incorrect oil level reading.
2. To check gear oil level (and to add oil, if necessary), see Section 2, STEP 5: Check Gear Oil Level in Transmission. Also see B. To Drain and Refill Transmission in this section.

**B. To Drain and Refill the Transmission:**

The transmission gear oil does not need changing unless it has been contaminated with dirt, sand or metal particles.

1. Prop up left side of unit so that it is securely supported. Remove left-side wheel by removing wheel mounting hardware.

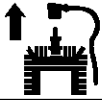

**WARNING**

Before inspecting, cleaning or servicing the machine, shut off engine, wait for all moving parts to come to a complete stop, remove ignition key on electric start models, disconnect spark plug wire and move wire away from spark plug.

Failure to follow these instructions can result in serious personal injury or property damage.

2. Unscrew plastic gear oil fill plug from top of transmission.

3. Place a clean pan below the transmission drain plug (see Figure 5-3) and then remove the drain plug. Oil will flow from the drain hole (it may flow slowly, especially in cold temperatures).

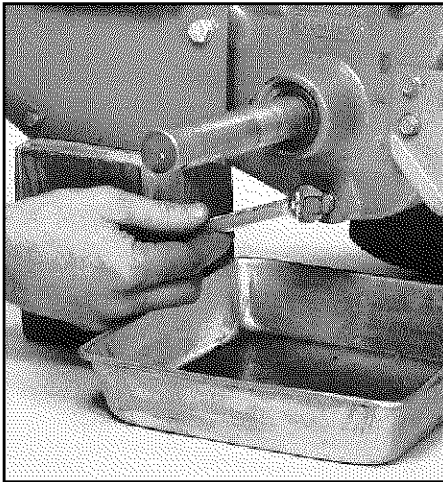

*Figure 5-3: Remove drain plug to drain transmission gear oil (also remove oil fill plug and oil level check plug).*

4. Remove transmission gear oil level check plug located a few inches above left-side wheel shaft.

5. When oil stops flowing, tilt transmission forward to drain oil from rear of transmission.

6. After draining oil, clean threads of drain plug, apply non-hardening, removable gasket sealant to threads, and securely reinstall drain plug.

7. Use a clean funnel to slowly add SAE 140 or SAE 85W-140 weight gear oil (API rating of GL-4 only) to the transmission. The transmission holds approximately 3-1/4 pints (52-54 ounces). Tilt the tiller slightly backwards to make sure the gear oil reaches the rear (tine) end of the transmission. Stop adding gear oil when it begins to flow from the oil level check hole on the side of transmission.

8. Securely reinstall oil level check plug.

9. Securely reinstall gear oil fill plug on top of transmission.

10. Reinstall wheel and remove prop.

**ENGINE OIL SERVICE**

Check motor oil level before starting engine each day and after each 5 hours of continuous operation. Running engine when oil level is low will quickly ruin engine.

It is recommended that you change motor oil after every 10 hours of operation and even sooner when operating in extremely dirty or dusty conditions.

**A. To Check Motor Oil Level:**

1. Move tiller to level area and stop engine.

2. Level engine by putting Depth Regulator Lever into second notch from top.

3. Clean area around oil dipstick or oil fill tube (whichever applies) to prevent dirt from falling into crankcase.

4. On engines with an oil fill tube, remove filler cap and add oil (if required) until it reaches top of tube. Reinstall filler cap.

5. On engines with a dipstick, remove, wipe clean, and reinstall finger-tight. Remove dipstick again and check reading. Add oil (if required) to FULL mark. Do not overfill. Refer to Engine Owner's Manual for complete details.

**B. To Change Motor Oil:**

Change motor oil as instructed in separate Engine Owner's Manual.

**AIR CLEANER SERVICE**

The engine air cleaner filters dirt and dust out of the air before the air enters the carburetor. Operating the engine with a dirty, clogged air filter can cause poor performance and damage the engine. Never operate the engine without an air cleaner installed. Inspect and service the air cleaner more often if operating in very dusty or dirty conditions.

Service the air cleaner as instructed in the Engine Owner's Manual.

**SPARK PLUG SERVICE**

Inspect and clean or replace the spark plug after every 100 operating hours or annually. Clean the plug and set the gap as described in Engine Owner's Manual.

**SPARK ARRESTER SCREEN SERVICE**

If the engine muffler is equipped with a spark arrester screen, remove and clean it according to the time intervals and instructions in the separate Engine Owner's Manual.

**ENGINE CLEANING**

The engine must be kept clean to assure smooth operation and to prevent damage from overheating. Refer to the Engine Owner's Manual for specific repair and cleaning instructions. All inspections and services must be done with the engine shut off and cool to the touch.

**CARBURETOR/GOVERNOR CONTROL ADJUSTMENTS****WARNING**

Operators shall not tamper with the engine governor settings; the governor controls the maximum safe operating speed to protect the engine and all moving parts from damage caused by overspeed. Authorized service shall be sought if a problem exists.

The carburetor was adjusted at the factory for best operating speed. Refer to the separate Engine Owner's Manual for any adjustment information or see your authorized engine service dealer.

The governor controls the maximum safe operating speed and protects the engine and all moving parts from damage caused by overspeeding. Do not tamper with the engine governor settings. Seek an authorized service dealer if a problem exists.

**THROTTLE CONTROL ADJUSTMENT**

If the engine does not respond to various throttle lever settings, refer to the separate Engine Owner's Manual for service information or contact your local authorized engine service dealer.

**WHEEL GEAR CABLE ADJUSTMENT**

When the Wheel Gear Lever is in DISENGAGE, the wheels will roll freely (free-wheel). The wheels should not roll freely when the lever is in ENGAGE. If the

## WARNING

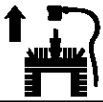

Before inspecting, cleaning or servicing the machine, shut off engine, wait for all moving parts to come to a complete stop, remove ignition key on electric start models, disconnect spark plug wire and move wire away from spark plug.

Failure to follow these instructions can result in serious personal injury or property damage.

wheels roll freely when the Wheel Gear Lever is in ENGAGE, the wheel gear cable needs to be adjusted as described below.

1. With engine shut off and spark plug wire disconnected, put Wheel Gear Lever in ENGAGE.
2. Loosen top adjustment nut (A, Figure 5-4) on wheel gear cable bracket located on left side rear of transmission.

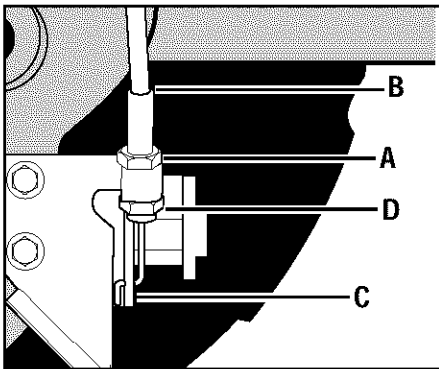

Figure 5-4: Wheel gear cable assembly.

3. Push wheel gear cable (B) down and roll tiller slightly forward or backward until eccentric lever (C) engages (locks) wheels. Hold cable in that position and tighten top (A) and bottom (D) adjustment nuts.
4. Move Wheel Gear Lever into ENGAGE and DISENGAGE several times to check adjustment. The wheels should not roll when lever is in ENGAGE, but should roll when lever is in DISENGAGE. Readjust cable as required.

## OFF SEASON STORAGE

To prepare tiller for extended storage:

1. Clean tiller and engine.
2. Do routine tiller lubrication (see *Tiller Lubrication*) and check for loose parts and hardware (see *Check Hardware*).
3. Protect engine by performing the recommended engine storage instructions in Engine Owner's Manual. NOTE: Be sure to protect fuel lines, carburetor and fuel tank from gum deposits by removing fuel or by treating fuel with fuel stabilizer (follow engine manufacturer's recommendations).

4. Store unit in a clean, dry area.

5. Never store tiller with fuel in fuel tank in an enclosed area where gas fumes could reach an open flame or spark, or where ignition sources are present (space heaters, hot water heaters, furnaces, etc.).

## BOLO TINES

Tines will wear with use and should be inspected at the beginning of each tilling season and after every 30 operating hours. Tines can be replaced individually or as a complete set. Never inspect or service tines unless engine is stopped, spark plug wire is disconnected, and ignition key is removed on electric start models.

### A. Tine Inspection:

With use, tines will become shorter, narrower and pointed (Figure 5-5). Badly worn tines result in loss of tilling depth and reduced effectiveness when chopping up and turning under organic matter. Use Figure 5-5 as a guide to when to replace tines.

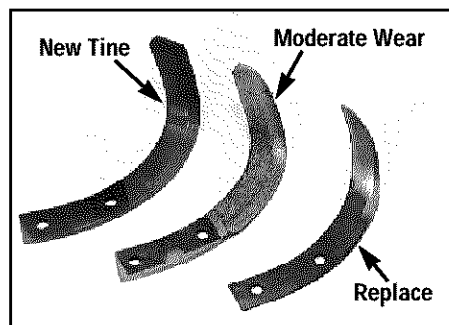

Figure 5-5: Checking tines for wear.

### B. Removing a Single Tine:

1. With engine shut off and spark plug wire disconnected, remove two screws and nuts that attach a single tine to a tine holder (Figure 5-6). If needed, use penetrating oil to help free nuts.
2. When installing a single tine, be sure to position it so that its *cutting edge enters the soil first as the tiller moves forward*.

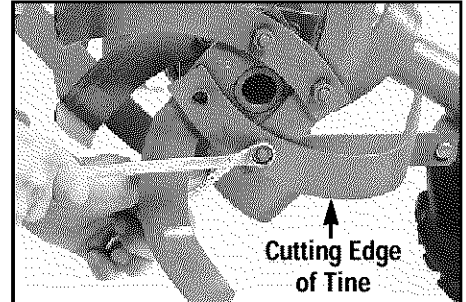

Figure 5-6: Removing single tine.

### C. Removing and Installing Tine Assemblies:

1. With engine shut off and spark plug wire disconnected, remove tine hood by removing two attaching screws at rear of hood and two attaching screws at front of hood.
2. If removing both tine assemblies, mark them "left" and "right" before removal. Remove the screw and locknut that secure the tine assembly to the tine shaft (Photo 5-7). If necessary, use a rubber mallet to tap tine assembly outward off shaft.

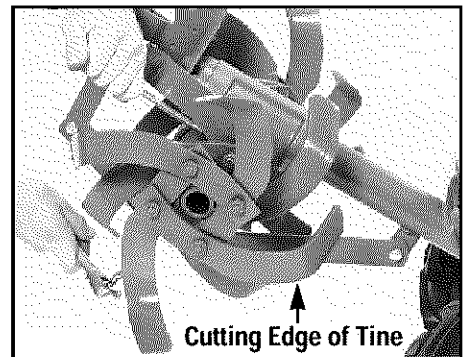
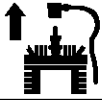

Figure 5-7: Removing tine assembly.

3. Before reinstalling a tine assembly, inspect tine shaft for rust, rough spots or burrs and file or sand as needed. Apply a thin coat of grease to shaft.
4. Install each tine assembly so that the *cutting edge of tines enter soil first when tiller moves forward*. Secure tine assembly to tine shaft using screw and locknut previously removed. Tighten securely.
5. Replace tine hood using four screws previously removed. Tighten securely.

**⚠ WARNING**

Before inspecting, cleaning or servicing the machine, shut off engine, wait for all moving parts to come to a complete stop, remove ignition key on electric start models, disconnect spark plug wire and move wire away from spark plug.

Failure to follow these instructions can result in serious personal injury or property damage.

### CHECKING AND ADJUSTING TENSION ON CLUTCH BELT

**⚠ WARNING**

Follow the belt adjustment instructions carefully. An incorrect adjustment could result in the clutch control mechanism engaging too soon. This could cause loss of tiller control and result in personal injury or property damage.

Maintaining correct belt tension is important to good tilling performance and long belt life. A loose belt will slip on the engine and transmission pulleys and cause the tines and wheels to slow down – or stop – even though the engine is running at full speed. A loose belt will also result in premature belt wear.

While checking belt tension, also check for cracks, cuts or frayed edges. A belt in poor condition should be replaced.

Tension on a new forward clutch belt (C, Figure 5-8) should be checked after the first two (2) hours of operation and after every ten (10) hours of operation.

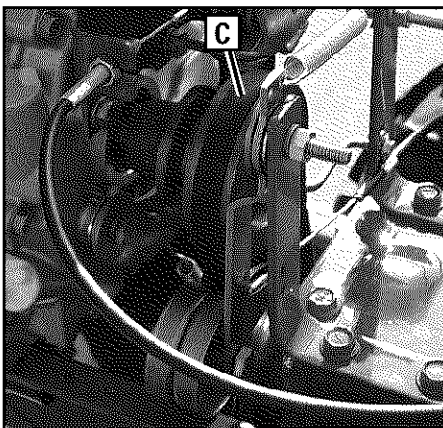

Figure 5-8: Forward clutch belt (C). (Left-side view, no belt cover.)

The reverse clutch belt (D, Figure 5-9), because it is used more sparingly, may not require tension adjustment until a significant number of operating hours has passed. A tension adjustment is required only if there is little or no reverse movement when the Reverse Clutch Control knob is pulled out.

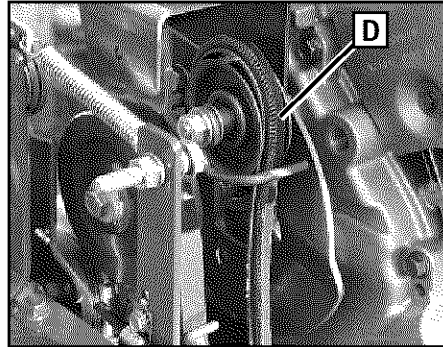

Figure 5-9: Reverse clutch belt (D). (Right-side view, no belt cover.)

### Checking and Adjusting Forward Clutch Belt Tension

#### Checking Forward Belt Tension

1. Before adjusting, shut off engine, allow the engine and muffler to cool down, disconnect the spark plug wire, and remove the ignition key on electric start models.
2. The coiled part of the forward clutch spring (E, Figure 5-10) measures 2" in length when the Forward Clutch Control levers (G) are not pulled up. Pull either Forward Clutch Control Lever up against the handlebar and measure the length of the extended coil. Tension is correct if the length of the extended coil is 2-1/2" (see Figure 5-11). The forward clutch control cable needs adjustment if the extended length of the coil is not 2-1/2". See *Adjusting the Forward Clutch Belt* for a procedure.

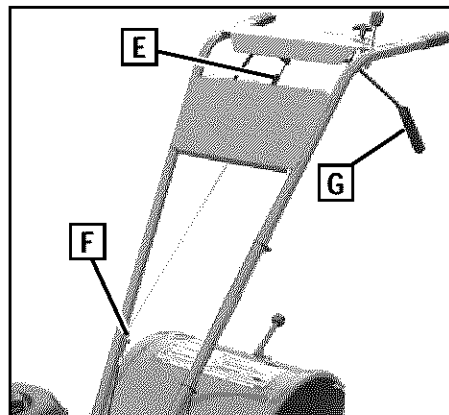

Figure 5-10: Location of forward clutch cable spring (E) and forward cable adjuster (F).

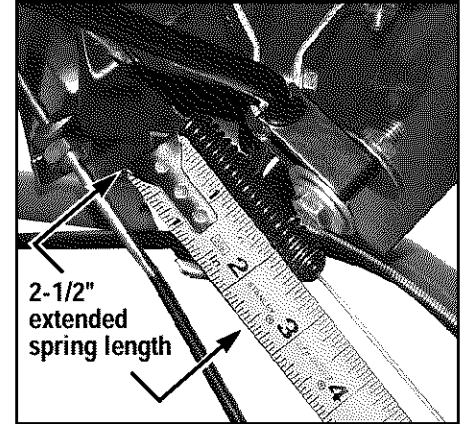

Figure 5-11: Correct spring length when Forward Clutch Levers are engaged is 2-1/2".

### Adjusting the Forward Clutch Belt

**⚠ CAUTION**

Incorrect cable adjustment could cause the wheels and tines to rotate unexpectedly. Follow adjustment procedures carefully. Failure to do so could result in personal injury or property damage.

Do this procedure if the forward clutch spring measurement is not correct (see *Checking Forward Belt Tension*).

1. Before adjusting, shut off engine, allow the engine and muffler to cool down, disconnect the spark plug wire, and remove the ignition key on electric start models.
2. Belt adjustments are done with the forward clutch cable adjuster (F, Figure 5-10). Use two 1/2", open-end wrenches to loosen the two jam nuts (A, Figure 5-12) a few turns.

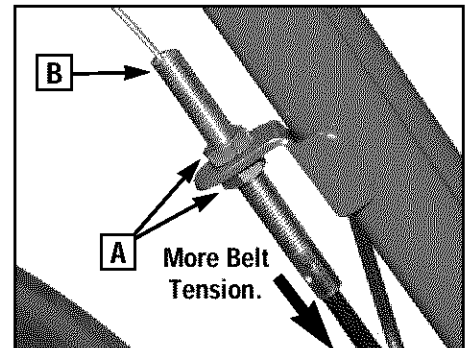
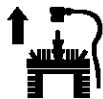

Figure 5-12: Move forward clutch cable adjuster down for more belt tension.

## ⚠ WARNING



Before inspecting, cleaning or servicing the machine, shut off engine, wait for all moving parts to come to a complete stop, remove ignition key on electric start models, disconnect spark plug wire and move wire away from spark plug.

Failure to follow these instructions can result in serious personal injury or property damage.

NOTE: Do not loosen the nuts more than a few turns for each adjustment check.

3. Move cable adjuster (B, Figure 5-12) downward for more belt tension.

4. Hand tighten the jam nuts and pull the Forward Clutch Control levers up against the handlebar. Measure the spring coil (Figure 5-11). The extended length of the coil should be 2-1/2". Repeat this procedure until the extended spring length is correct.

NOTE: A new belt is needed when the jam nuts are adjusted close to the end of the threaded adjuster.

5. Tighten both jam nuts securely.

### Checking and Adjusting Reverse Clutch Belt Tension

#### Checking Reverse Clutch Belt Tension

The reverse clutch belt (D, Figure 5-9) needs adjustment if the belt slips in reverse or if there is no reverse. See *Adjusting Reverse Clutch Belt* below.

#### Adjusting Reverse Clutch Belt

1. Before adjusting the belt, shut off engine, allow the engine and muffler to cool down, disconnect the spark plug wire, and remove the ignition key on electric start models.

2. Remove the two flange locknuts (C, Figure 5-13) and remove the belt cover.

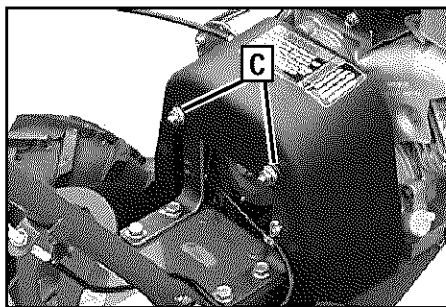

Figure 5-13: Belt cover.

3. Reverse belt tension adjustments are done with the reverse clutch cable adjuster located on the left side of the machine near the engine (D, Figure 5-14). Use two 1/2" open-end wrenches to loosen the two adjuster jam nuts (E) a few turns.

NOTE: Do not loosen the nuts more than a few turns for each adjustment check.

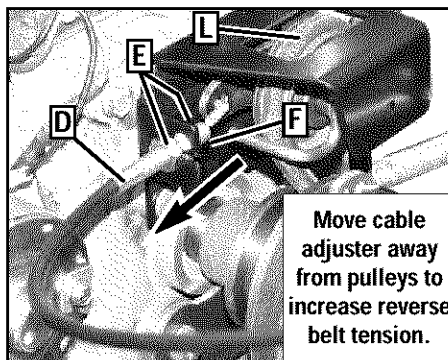

Figure 5-14: Reverse clutch cable adjuster. Left-side view with belt cover removed.

4. Move the cable adjuster (D, Figure 5-14) away from the pulleys to increase belt tension.

NOTE: A new belt is needed when the jam nuts are adjusted close to the end of the threaded adjuster.

5. Tighten both jam nuts securely.

6. Pull back on the Reverse Clutch Control knob and make sure that the reverse clutch belt fully contacts the groove in the engine pulley. Release knob and make sure that the belt doesn't engage the reverse engine pulley (L, Figure 5-14). If it does, it may cause the unit to move in reverse when the Wheel Gear Lever is engaged. Adjust the cable for less tension if this condition occurs. See *Checking and Adjusting Reverse Belt Tension* for more information.

7. Reinstall the belt cover.

8. Move the unit to an open area and test the reverse operation. Repeat this procedure if the unit does not respond when the reverse clutch is engaged.

### FORWARD CLUTCH BELT REMOVAL AND REPLACEMENT

The forward clutch belt (K, Figure 5-15) engages the engine pulley (I) and the transmission pulley (J) when either Forward Clutch Control Lever is pulled up against the handlebar. Pulling the lever(s) tightens the forward clutch cable (G) which causes the forward clutch idler pulley (H) to apply tension to the forward clutch belt. This causes the belt to transfer power from the engine pulley to the transmission pulley for Forward movement.

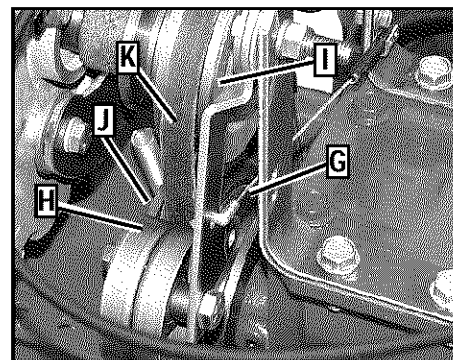

Figure 5-15: Forward clutch control assembly.

### Removing Forward Clutch Belt

1. Stop engine, allow it to cool and disconnect spark plug wire before working near belts. Also remove ignition key on electric start models.

2. Remove the two nuts (C, Figure 5-13) and remove the belt cover.

3. Move the reverse clutch belt (A, Figure 5-16) out of the way. Press on the reverse idler pulley to create slack. Then slip the bottom half of the belt completely off the transmission pulley. Pull the bottom half of the belt out of the housing and let it hang outside the unit (B).

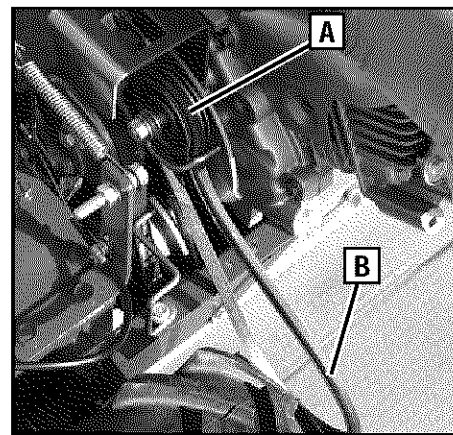
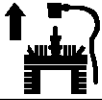

Figure 5-16

4. On left-side of unit, disconnect the forward clutch cable from the forward clutch idler arm bracket (Figure 5-17). Note the hole from which you disconnect the cable. It is important to reconnect the cable to the same hole.

**WARNING**

Before inspecting, cleaning or servicing the machine, shut off engine, wait for all moving parts to come to a complete stop, remove ignition key on electric start models, disconnect spark plug wire and move wire away from spark plug.

Failure to follow these instructions can result in serious personal injury or property damage.

Press Forward Clutch Idler Arm inward to take pressure off Clutch Cable.

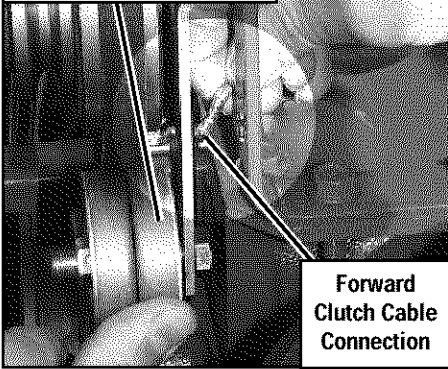

Figure 5-17

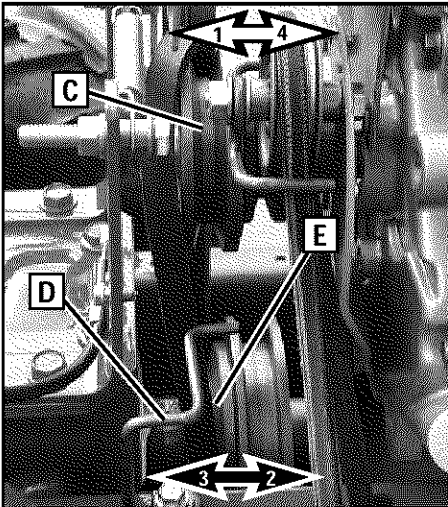

Figure 5-18: Right-side view.

5. Slide the forward clutch belt off the engine pulley (C, Figure 5-18), away from engine (in the direction of arrow 1), out from behind the belt guide (D), and completely off the pulley.

6. Slip the belt off the front of the transmission pulley (E, Figure 5-18, in the direction of arrow 2).

7. Work the belt out from between the pulley and the frame, around the transmission cover spring, then up and out of the machine.

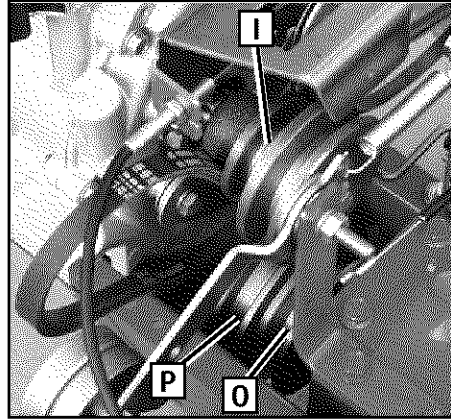

Figure 5-19

### Installing Forward Clutch Belt

1. Stop engine, allow it to cool and disconnect spark plug wire before working near belts. Also remove ignition key on electric start models.

2. Remove the old forward clutch belt as described in *Removing Forward Clutch Belt*.

3. From the front of tiller, insert the forward clutch belt in between the bottom of the engine pulley (I, Figure 5-19) and the top of transmission pulley (P).

4. Insert the bottom half of belt into the smaller, rear-most groove of the transmission pulley (E, Figure 5-18, in the direction of arrow 3). Now slip the top half of belt behind the belt guide (D, Figure 5-18, in the direction of arrow 4) and onto the large groove of engine pulley (C, Figure 5-18).

5. Reconnect the forward clutch cable to the correct hole in the idler arm bracket, as shown in Figure 5-17.

NOTE: Be sure to position the clutch cable on the pulley side (G, Figure 5-20) of the left-side cover support bracket (J).

**IMPORTANT:** Belt must be installed behind the belt guide (H, Figure 5-20).

6. Reinstall the reverse clutch belt. Insert the bottom of the belt into the frame, then pull down on the belt and slip it onto the large, forward-most groove of the transmission pulley (P, Figure 5-19).

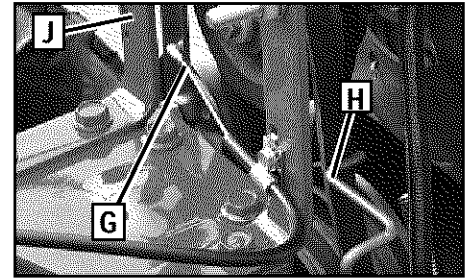

Figure 5-20: Correct forward clutch cable positioning.

7. Pull back on the Reverse Clutch Control knob and make sure that the reverse clutch belt fully contacts the groove in the engine pulley. Release knob and make sure that the belt doesn't engage the reverse engine pulley. If it does, it may cause the unit to move in reverse when the Wheel Gear Lever is engaged. Adjust the cable for less tension if this condition occurs. See *Checking and Adjusting Reverse Belt Tension*.

8. Reinstall the belt cover.

9. Test for correct tension on the forward clutch belt. See *Checking Forward Belt Tension*.

10. Move the unit to an open area and test the reverse operation. It needs adjustment if the belt slips in reverse or if there is no reverse. See *Adjusting Reverse Clutch Belt*.

### REVERSE CLUTCH BELT REMOVAL AND REPLACEMENT

The reverse clutch belt (J, Figure 5-21) is driven by the engine pulley (I, Figure 5-19). When the Reverse Clutch Control knob is pulled out, it pulls the reverse idler arm and pulley (N, Figure 5-21) inward, which tightens the belt against the engine pulley. This drives the transmission pulley (L), resulting in reverse motion.

#### Removing Reverse Clutch Belt

1. Stop engine, allow it to cool and disconnect spark plug wire before working near belts. Also remove ignition key on electric start models.

2. Remove belt cover (Figure 5-13) by removing two flange locknuts (C).



## WARNING



Before inspecting, cleaning or servicing the machine, shut off engine, wait for all moving parts to come to a complete stop, remove ignition key on electric start models, disconnect spark plug wire and move wire away from spark plug.

Failure to follow these instructions can result in serious personal injury or property damage.

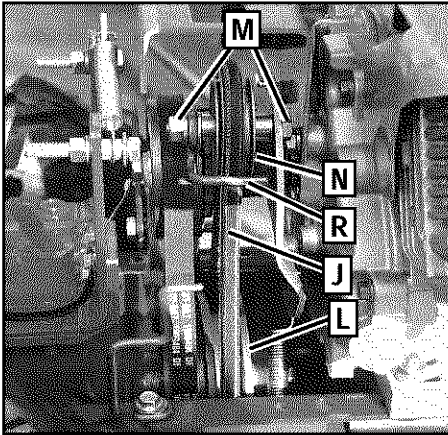

Figure 5-21: Right-side view.

3. Pull the reverse clutch belt downward and slip it off the transmission pulley (L, Figure 5-21).

4. Use two 1/2" wrenches to loosen and remove wire belt guide (R, Figure 5-21) from the reverse idler arm pulley. Do not remove locknut and screw.

5. Remove the reverse belt and pull it out through front of transmission housing.

### Installing Reverse Clutch Belt

1. Stop engine, allow it to cool and disconnect spark plug wire before working near belts. Also remove ignition key on electric start models.

**IMPORTANT:** The forward clutch belt must be installed before the reverse clutch belt (see *Installing Forward Clutch Belt* in this Section).

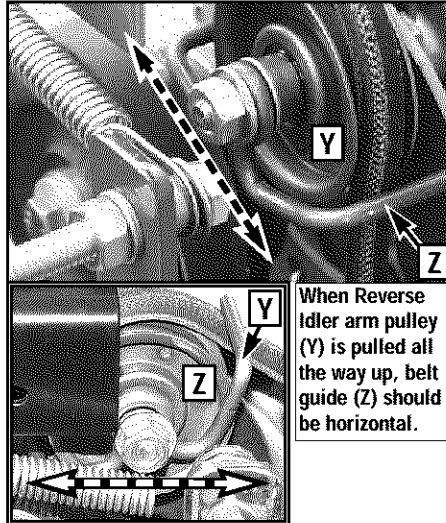

Figure 5-22: Reverse belt guide positioning.

**IMPORTANT:** The reverse belt has a "V" shape. When installing the belt, make sure that the widest (flat) side of the belt rides against the reverse idler pulley (N, Figure 5-21) and transmission pulley (L). If needed, the belt can be twisted "inside out" so that the "V" shaped side is on the outside and the widest side is on the inside.

2. Insert the belt down into the front of the transmission housing. Slip the top half of the belt onto the reverse idler arm pulley (N, Figure 5-21).

3. Pull the belt downward and loop the bottom half of belt around the front groove of transmission pulley (L, Figure 5-21).

4. Mount the belt guide between the two flat washers and tighten snugly. The guide needs adjusting before fully tightening.

5. (You will need an assistant to help with this step.) Pull the reverse idler pulley (Y) up to its highest point and position the belt guide (Z) horizontally level as shown in Figure 5-22. Securely tighten the screw and locknut (M, Figure 5-21).

6. Pull back on the Reverse Clutch Control knob and make sure that the reverse clutch belt fully contacts the groove in the engine pulley. Release knob and make sure that the belt doesn't engage the reverse engine pulley. If it does, it may cause the unit to move in reverse when the Wheel Gear Lever is engaged. Adjust the cable for less tension if this condition occurs. See *Checking and Adjusting Reverse Belt Tension* for more information.

7. Reinstall the belt cover and secure it with two flange locknuts.

8. Test the unit in an open location.

9. Move the unit to an open area and test the reverse operation. It needs adjustment if the belt slips in reverse or if there is no reverse. See *Adjusting Reverse Clutch Belt*.

## TILLER ATTACHMENTS

The attachments listed below are available for your tiller. The information is the most current at the time this manual was printed. Contact your authorized dealer or the Factory for current information.

### HILLER/FURROWER

The furrower blade attaches to the back of the depth regulator assembly and is used to create rows, trenches and ditches up to 8" deep, depending on soil conditions. The two hiller wings attach to the sides of the furrower blade and are used to make hilled rows and raised bed gardens.

### ROW MARKER

The row marker attaches to the hiller/furrower attachment and is used to scratch lines in the seedbed for laying out furrows, trenches, raised beds, etc. (eliminates the need for stakes, string and measuring tape). The row marker is adjustable in length from 28" to 49-3/4", allowing you to vary the width of the marked rows, as required.

## TROUBLESHOOTING

Before performing any troubleshooting procedures, refer to the appropriate safety, operating or maintenance instructions in this Manual or in the Engine Owner's Manual. Contact your local authorized engine service dealer for engine service. Contact your local authorized tiller dealer or the factory for all other service problems.

PROBLEM	POSSIBLE CAUSE	CORRECTION
<b>Engine does not start.</b>	<ol style="list-style-type: none"> <li>1. Spark plug wire disconnected.</li> <li>2. Engine Throttle Control Lever incorrectly set.</li> <li>3. Fuel tank empty.</li> <li>4. Choke control (if so equipped) in incorrect position.</li> <li>5. Stale gasoline.</li> <li>6. Dirty air filter(s).</li> <li>7. Defective or incorrectly gapped spark plug.</li> <li>8. Carburetor out of adjustment.</li> <li>9. Misadjusted throttle control.</li> <li>10. Dirt or water in fuel tank.</li> </ol>	<ol style="list-style-type: none"> <li>1. Reconnect wire.</li> <li>2. Put lever in START position.</li> <li>3. Add fuel.</li> <li>4. See Engine Owner's Manual.</li> <li>5. Drain fuel and add fresh fuel.</li> <li>6. Clean or replace filter(s).</li> <li>7. Inspect spark plug.</li> <li>8. See Engine Service Dealer.</li> <li>9. See Engine Service Dealer.</li> <li>10. See Engine Service Dealer.</li> </ol>
<b>Engine runs poorly.</b>	<ol style="list-style-type: none"> <li>1. Defective or incorrectly gapped spark plug.</li> <li>2. Dirty air filter(s).</li> <li>3. Carburetor out of adjustment.</li> <li>4. Stale gasoline.</li> <li>5. Dirt or water in fuel tank.</li> <li>6. Engine cooling system clogged.</li> </ol>	<ol style="list-style-type: none"> <li>1. Inspect spark plug (see Engine Owner's Manual).</li> <li>2. Clean or replace (see Engine Owner's Manual).</li> <li>3. See Engine Service Dealer.</li> <li>4. Replace with fresh gasoline.</li> <li>5. See Engine Service Dealer.</li> <li>6. Clean air cooling system (see Engine Owner's Manual).</li> </ol>
<b>Engine overheats.</b>	<ol style="list-style-type: none"> <li>1. Engine cooling system clogged.</li> <li>2. Carburetor out of adjustment.</li> <li>3. Oil level is low.</li> </ol>	<ol style="list-style-type: none"> <li>1. Clean air cooling area (see Engine Owner's Manual).</li> <li>2. See Engine Service Dealer.</li> <li>3. Check oil level (see Engine Owner's Manual).</li> </ol>
<b>Engine does not shut off.</b>	Misadjusted/faulty engine switch.	See Engine Owner's Manual or Engine Service Dealer.
<b>Wheels and Tines will not turn.</b>	<ol style="list-style-type: none"> <li>1. Improper use of controls.</li> <li>2. Forward Clutch: Misadjusted forward clutch control cable.</li> <li>3. Reverse Clutch: Misadjusted clutch control cable.</li> <li>4. Worn or broken clutch belt(s).</li> <li>5. Internal transmission wear or damage.</li> <li>6. Screw and key loose in transmission pulley.</li> </ol>	<ol style="list-style-type: none"> <li>1. Review Sections 3 and 4.</li> <li>2. Adjust cable tension (Section 5).</li> <li>3. Adjust cable tension (Section 5).</li> <li>4. Check belts. Replace parts as needed (Section 5).</li> <li>5. Contact local dealer or Factory.</li> <li>6. Tighten screw; check that key is in place.</li> </ol>
<b>Tines turn, but wheels don't.</b>	<ol style="list-style-type: none"> <li>1. Wheel mounting hardware missing.</li> <li>2. Screw and key loose in transmission pulley.</li> <li>3. Internal transmission wear or damage.</li> <li>4. Misadjusted wheel gear cable.</li> <li>5. Wheel Gear Lever not fully engaged.</li> </ol>	<ol style="list-style-type: none"> <li>1. Replace hardware.</li> <li>2. Tighten screw; check that key is in place.</li> <li>3. Contact local Dealer or Factory.</li> <li>4. See <i>Wheel Gear Cable Adjustment</i>, Section 5.</li> <li>5. Engage lever (see Section 3).</li> </ol>
<b>Wheels Turn, but Tines Don't.</b>	<ol style="list-style-type: none"> <li>1. Tine holder mounting hardware missing.</li> <li>2. Internal transmission wear or damage.</li> </ol>	<ol style="list-style-type: none"> <li>1. Replace hardware.</li> <li>2. Contact local Dealer or Factory.</li> </ol>
<b>Poor tilling performance.</b>	<ol style="list-style-type: none"> <li>1. Worn tines.</li> <li>2. Improper Depth Regulator setting.</li> <li>3. Incorrect throttle setting.</li> <li>4. Belt(s) slipping.</li> </ol>	<ol style="list-style-type: none"> <li>1. See <i>Bolo Tines</i> (Section 5).</li> <li>2. See <i>Tilling Tips &amp; Techniques</i>, Section 4.</li> <li>3. See Section 4.</li> <li>4. See <i>Checking Clutch Belt Tension</i>, Section 5.</li> </ol>

DRAWING NO. 1

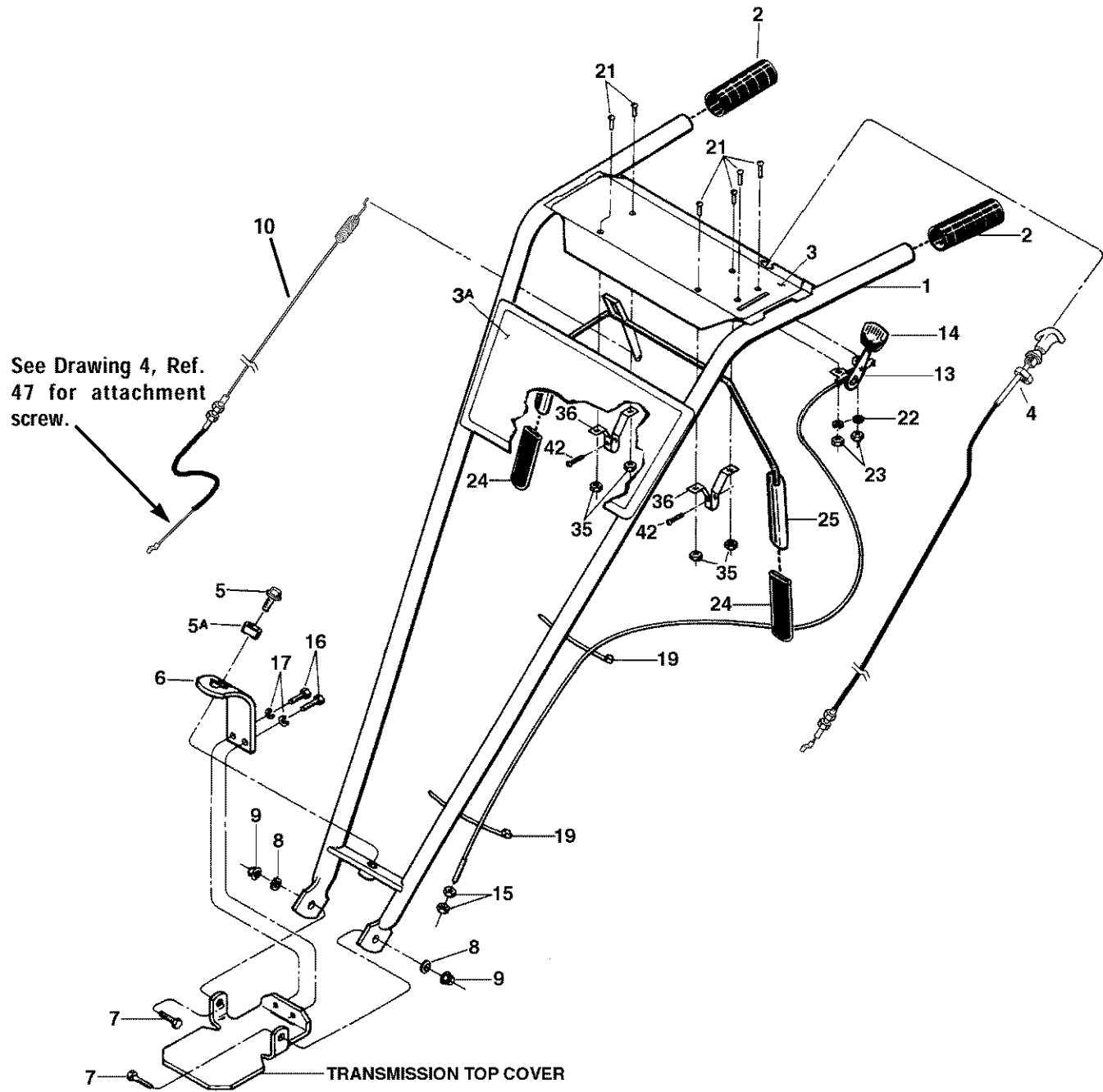



**PARTS LIST - DRAWING NO. 1**

REF No.	PART No.	DESCRIPTION	QTY.	REF No.	PART No.	DESCRIPTION	QTY.
1	1918791	Handlebars--(Incl. Refs. 2, 3 and 3A)...	1	15	1186211	Hex Nut, 5/16-24 - Wheel gear cable adjustment.....	2
2	9126	Grip .....	2	16	1100068	Hex Hd. Screw, 3/8-16 x 3/4* .....	2
3	1916931	Decal--Operator control panel .....	1	17	1100243	Lockwasher, 3/8 .....	2
3A	1916930	Decal--Logo .....	1	19	1735531	Plastic Tie .....	2
4	1916784	Reverse Clutch Cable Assembly.....	1	21	1114748	Round Hd. Screw, #10-32 x 1/2 .....	6
5	1186347	Height Adjustment Flange Screw.....	1	22	1100240	Lockwasher, #10 .....	2
5A	9955	Keyed Washer.....	1	23	1186208	Hex Nut, #10-32 .....	2
6	1900475001	Bracket--Handlebar height adjust .....	1	24	9390	Grip--Lever .....	2
7	1100046	Hex Hd. Screw, 3/8-16 x 1* .....	2	25	1918840	Lever--Forward Clutch Control (Incl. two Grips, Ref. 24) .....	1
8	9904	Plain Washer (flat), 3/8, S.A.E. ....	2	35	9853	Sems Nut.....	4
9	9837	Hex Locknut, 3/8-16 .....	2	36	20806	Bracket--Bail support .....	2
10	1918791	Cable, Forward Clutch Control .....	1	42	1100805	Hex Flange Screw, self-tapping, 1/4-20 x 1/2* .....	2
13	9442	Wheel Gear Control & Cable Assy. (Incl. Refs. 14, 15, 19, 21, 22 and 23) .....	1				
14	9057	Knob--Wheel gear control lever.....	1				

\* Specify GRADE 5 if ordering part locally.

DRAWING NO. 2

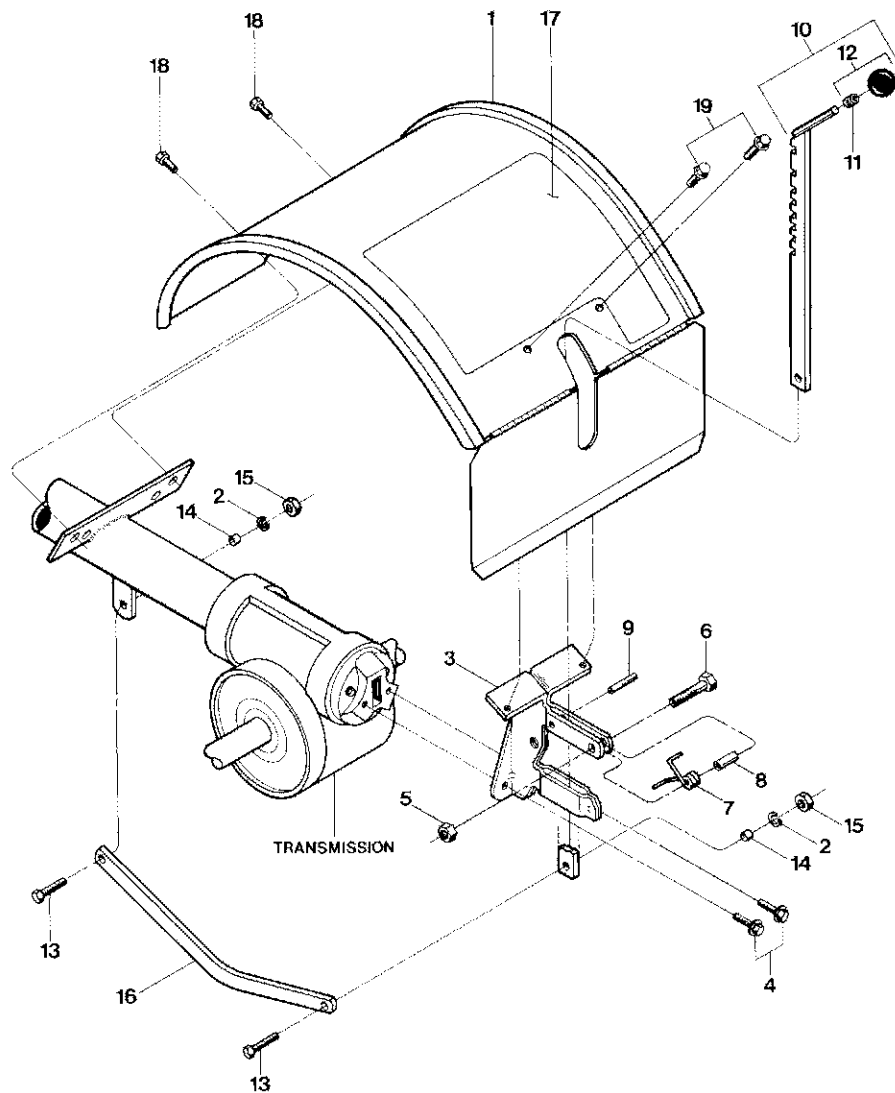

REF No.	PART No.	DESCRIPTION	QTY.
1	1917143	Hood-Tine cover, with hinged flap (Incl. Ref. 17).....	1
2	1100243	Lockwasher, 3/8.....	2
3	2527	Bracket-Hood & Depth Regulator (Incl. Ref. 9).....	1
4	90038	Screw-flanged hex hd., 5/16-18 x 5/8*.....	2
5	9811	Hex Locknut, 1/4-20.....	1
6	1100069	Hex Hd. Screw, 1/4-20 x 1*.....	1
7	9384	Spring-Depth regulator plunger.....	1
8	9438	Spacer.....	1
9	9308	Roll Pin-1/4 x 1 (spiral).....	1
10	1117A	Bar Assembly-Depth adjustment (Incl. Refs. 11 and 12).....	1

REF No.	PART No.	DESCRIPTION	QTY.
11	9120	Ring-Retaining, tolerance ring.....	1
12	9119	Knob-Depth regulator (Incl. Ref. 11).....	1
13	1100043	Hex Hd. Screw, 3/8-16 x 1-1/4*.....	2
14	1113-1	Bushing-Spacer.....	2
15	1186231	Hex Nut, 3/8-16.....	2
16	20775	Drag Bar.....	1
17	1917536	Decal-Tiller operating instructions.....	1
18	9553	Hex Hd. Screw, self-tapping, 5/16-18 x 1/2*.....	2
19	9552	Screw-flanged hex hd, self-tapping, 1/4-20 x 1/2*.....	2

\* Specify GRADE 5 if ordering part locally.

DRAWING NO. 3

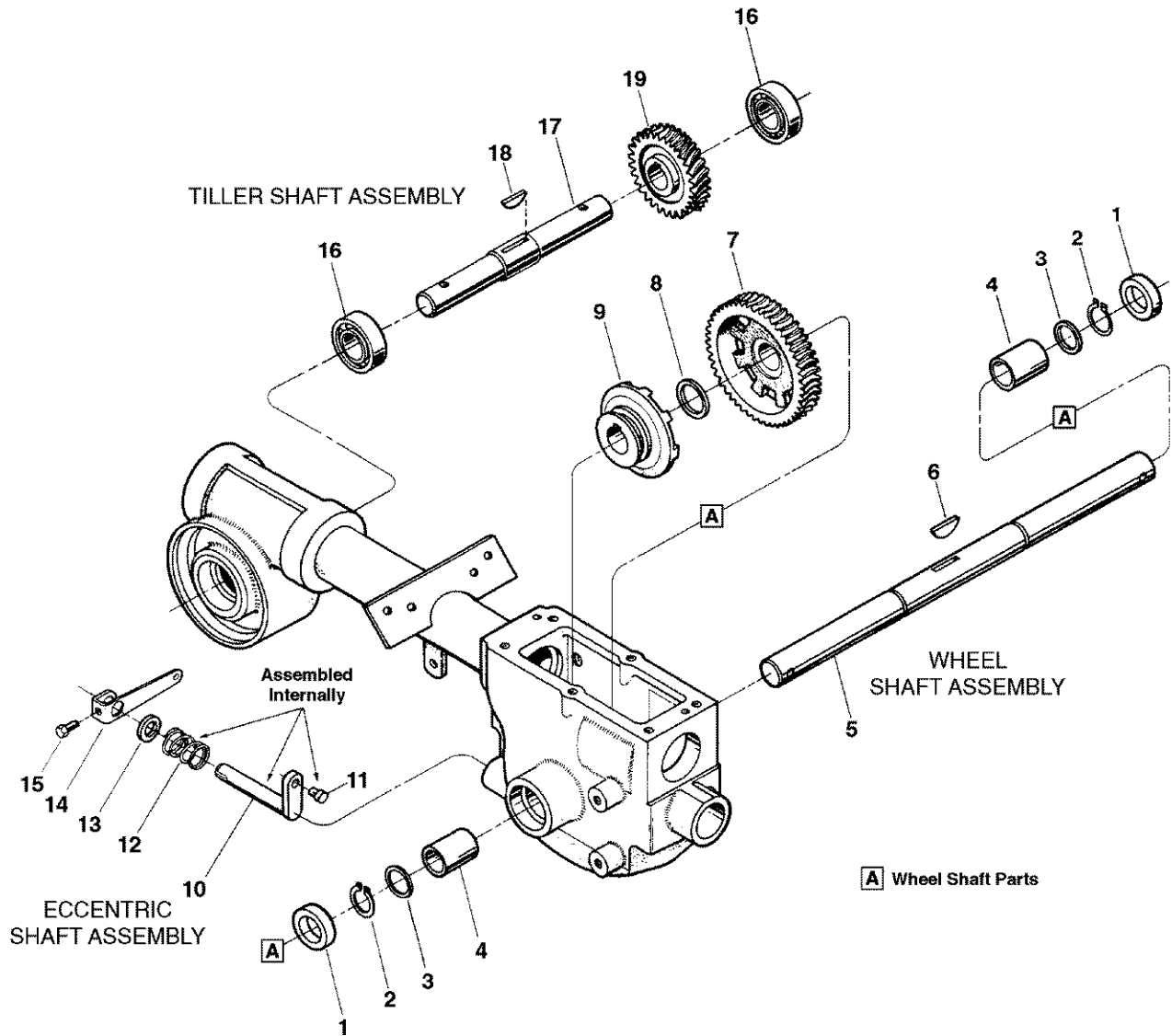

REF No.	PART No.	DESCRIPTION	QTY.	REF No.	PART No.	DESCRIPTION	QTY.
1	9621	Oil Seal.....	2	9	20712	Clutch-Wheel drive, cast iron.....	1
2	9511	Ring-Retaining, heavy-duty, ext.....	2	10	20879	Eccentric Shaft-Wheel clutch.....	1
3	1166-1	Shim-1-1/64 I.D., .062 thick.....	A/R	11	1442	Pin-Eccentric shaft.....	1
---	1166-2	Shim-as above, but .030 thick.....	A/R	12	9055	Spring.....	1
---	1166-3	Shim-as above, but .015 thick.....	A/R	13	9622	Oil Seal-Eccentric shaft.....	1
---	1166-4	Shim-as above, but .010 thick.....	A/R	14	20757	Lever-Eccentric shaft.....	1
4	1086	Bushing.....	2	15	11000804	Hex Hd. Screw, 1/4-20 x 1/2*.....	1
5	2494	Wheel Shaft (axle)-Incl. Ref. 6.....	1	16	97074	Ball Bearing.....	2
6	9373	Key-Hi-Pro, 1/4 x 1-5/16.....	1	17	20896	Tiller Shaft-Incl. Ref. 18.....	1
7	20914	Gear-Wheel drive (worm gear).....	1	18	1104	Key-Woodruff, 1/4 x 1-1/4.....	1
8	9935	Shim-1.016 I.D. x 1.468 O.D. x .062 thick.....	1	19	20913	Worm Gear-bronze, tiller drive.....	1

\* Specify GRADE 5 if ordering part locally.

A/R - As Required

DRAWING NO. 4

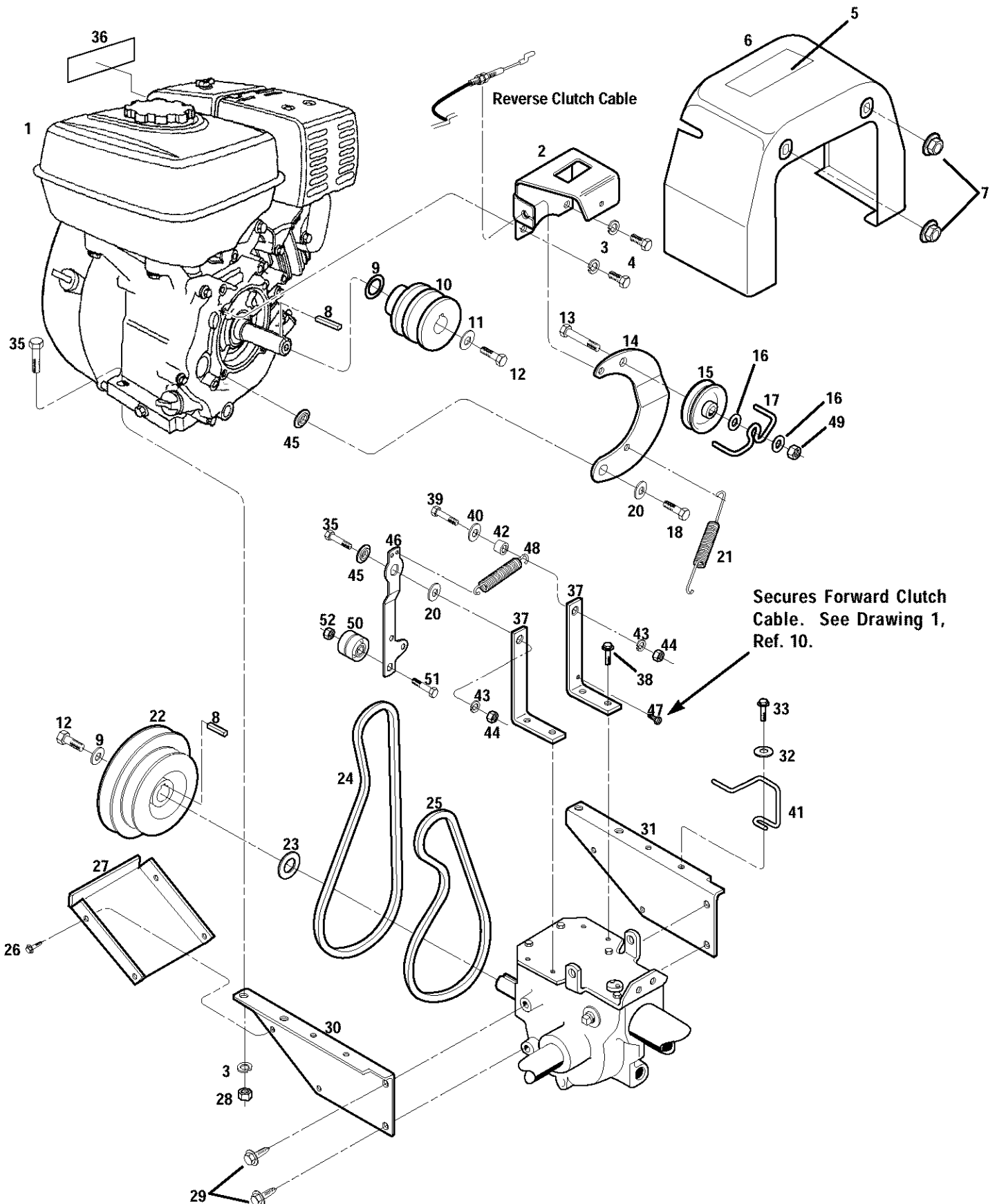

**PARTS LIST - DRAWING NO. 4**

REF. No.	PART No.	DESCRIPTION	QTY.	REF. No.	PART No.	DESCRIPTION	QTY.
1	**	Engine – standard recoil start .....	1	27	1916189001	Guard, Belts/Pulleys.....	1
2	1917326	Bracket, Clutch Cable .....	1	28	1186230	Hex Nut, 5/16–18 .....	4
3	1100242	Lockwasher–5/16.....	6	29	1186329	Hex Flange Screw, 5/16-18 x 3/4* .....	4
4	1111696	Hex Hd. Screw, 5/16-24 x 1/2 .....	2	30	1916797001	Engine Support Bracket, left side .....	1
5	1904557	Decal, Hot Surfaces/Belt Warning .....	1	31	1916796001	Engine Support Bracket, right side.....	1
6	1917139	Cover (Incl. Ref. 5).....	1	32	1107381	Flat Washer, 1/4 .....	1
7	1186391	Flange Locknut, 5/16-18 .....	2	33	1754128	Hex Flange Screw, 1/4-20 x 3/4 .....	1
8	1108841	Key, 3/16 x 1-1/2 .....	2	35	1100799	Hex Hd. Screw, 5/16–18 x 1-1/2 .....	3
9	1138-1	Shim .....	1	36	1915810	Decal, Stabilization.....	1
10	1916520	Pulley, Engine Drive .....	1	37	1918774001	Mounting Bar .....	2
11	9944	Belleville Washer .....	2	38	1186331	Hex Flange Screw, 5/16-18 x 1 .....	2
12	9572	Hex Hd. Screw, 5/16–24 x 1-1/8 .....	2	39	1111607	Hex Hd. Screw, 5/16-18 x 2-1/4* .....	2
13	1111606	Hex Hd. Screw, 5/16–18 x 2 .....	1	40	1107382	Flat Washer, 5/16' .....	1
14	1918731	Reverse Idler Arm .....	1	41	1918846	Belt Guide, Wire Formed, Fwd Belt.....	1
15	1916535	Pulley, Reverse Idler .....	1	42	55088	Pivot Bushing.....	2
16	1107382	Flat Washer, 5/16 .....	2	43	1100242	Lockwasher, 5/16.....	2
17	1916725	Belt Guide, Wire Formed .....	1	44	1186230	Hex Nut, 5/16-18.....	2
18	1100005	Hex Head Screw, 5/16-24 x 1.....	1	45	1917746	Washer, Shoulder .....	2
19	1917746	Washer, Shoulder .....	1	46	1918744	Idler Arm, Forward Tiller Direction.....	1
20	9929	Washer, Flat, 1-1/8.....	2	47	1767754	Screw, self tapping, #10-24 .....	1
21	1916728	Spring, Reverse Return.....	1	48	1916727	Spring .....	1
22	1916522	Transmission Pulley.....	1	49	1110107	Hex Locknut, 5/16-18 .....	1
23	1440	Support Washer .....	1	50	9090	Idler Pulley, Forward .....	1
24	1918812	Reverse Clutch Belt.....	1	51	1100086	Screw, 3/8-18 x 1-3/4 .....	1
25	1909404	Forward Clutch Belt.....	1	52	1110108	Hex Locknut, 3/8-16 .....	1
26	1900396	Hex Hd. Screw, #10-32 x 1/2, self-tapping .....	4				

\* Specify GRADE 5 if ordering part locally.

\*\* See your local authorized engine service dealer for engine parts or service. Refer to engine nameplate for engine type and code information.

**DRAWING NO. 5**

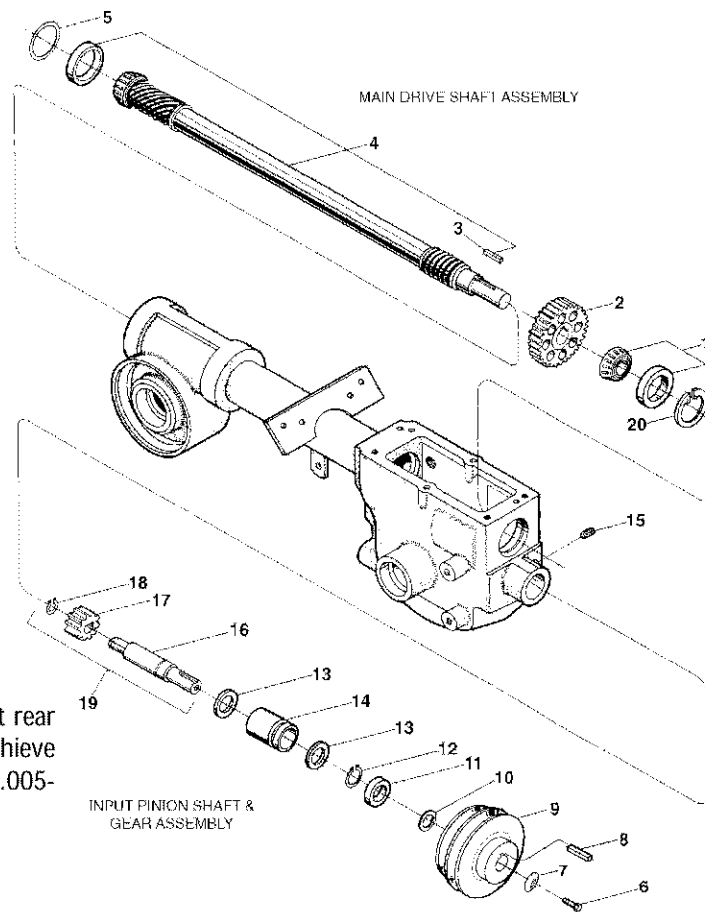

NOTE 1-Shim between drive shaft rear bearing and rear bearing cap to achieve 5-to-10 thousandths of an inch (.005-.010) end play on drive shaft.

REF No.	PART No.	DESCRIPTION	QTY.
<b>MAIN DRIVE SHAFT ASSEMBLY</b>			
1	1714	Bearing-Tapered roller with race .....	1
2	20718	Gear-Spur, main drive shaft .....	1
3	9301	Key, 3/16 sq. x 1 .....	1
4	11603	Drive Shaft-with integral, single-lead worm at front and six-lead worm at rear (includes pressed-on #1714 rear roller bearing, race for bearing and #9301 key) .....	1
5	1224-1	Shim-Rear bearing cap, .010 thick (see Note 1) .....	A/R
5	1224-2	Shim-same as above, but .030 thick (see Note 1) .....	A/R
5	1224-3	Shim-same as above, but .005 thick (see Note 1) .....	A/R
...	1325C	Shim Set-includes the following shims: two 1224-1; two 1224-2; one #1224-3 .....	A/R

REF No.	PART No.	DESCRIPTION	QTY.
<b>INPUT PINION SHAFT &amp; GEAR ASSEMBLY</b>			
6	9572	Hex Hd. Screw, 5/16-24 x 1-1/8* .....	1
7	9944	Washer-Disc spring (concave surface faces pulley).....	1
8	1108841	Key, 3/16 sq. x 1-1/2.....	1
9	20880	Pulley-Transmission drive .....	1
10	1440	Support Washer .....	1
11	85030	Oil Seal-Input pinion shaft, front.....	1
12	9500	Ring-Retaining (snap ring), external.....	1
13	9953	Thrust Washer.....	2
14	9428	Bushing.....	1
15	9677	Set Screw, 5/16-18 x 3/8*.....	1
16	20791	Input Pinion-steel shaft .....	1
17	20792	Gear-Input pinion .....	1
18	9093	Retainer-Snap ring, external .....	1
19	20799	Pinion Assy-(incl. one each of Ref. No.'s 16, 17 and 18 .....	A/R
20	9517	Retainer-Snap ring, internal.....	1

\* Specify GRADE 5 if ordering part locally.

A/R - As Required

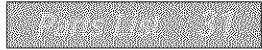

DRAWING NO. 6

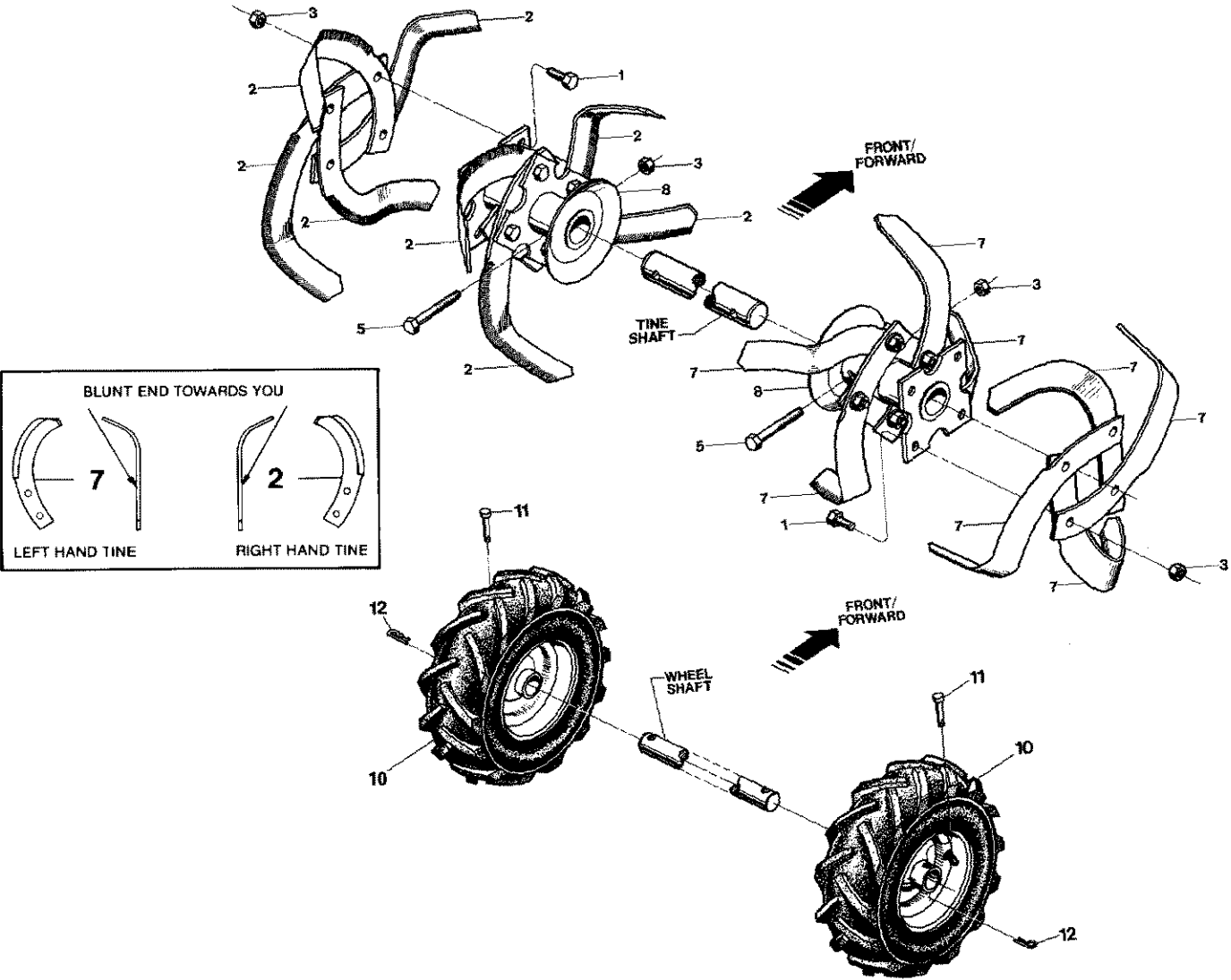

REF No.	PART No.	DESCRIPTION	QTY.
1	1100043	Hex Hd. Screw, 3/8-16 x 1-1/4*	16
2	1270-2A	Bolo Tine--single, right hand tine used on left side of tiller (Incl. two of each Ref. No.'s 1 and 3)	8
3	1733398	Hex Locknut, 3/8-16	18
5	1982612	Hex Hd. Screw, 3/8-16 x 2, GRADE 8	2
7	1270-1A	Bolo Tine--Single, left hand tine used on right side of tiller (Incl. two of each Ref. No.'s 1 and 3)	8

REF No.	PART No.	DESCRIPTION	QTY.
8	1902154001	Tine Holder--for bolo tines, left and right sides	2
--	1901118	Replacement set of 16 Bolo Tines-- includes eight each of right hand and left hand tines, and sixteen each of Ref. No.'s 1 and 3	1
10	1917487	Wheel & Tire Assembly	2
11	9380	Clevis Pin--.312 x 1-3/4 long	2
12	9338	Hitch Pin	2

\* Specify GRADE 5 if ordering part locally.

**IMPORTANT:** Left and right sides of tiller are determined by standing in the operator position and facing the direction of forward travel.

DRAWING NO. 7

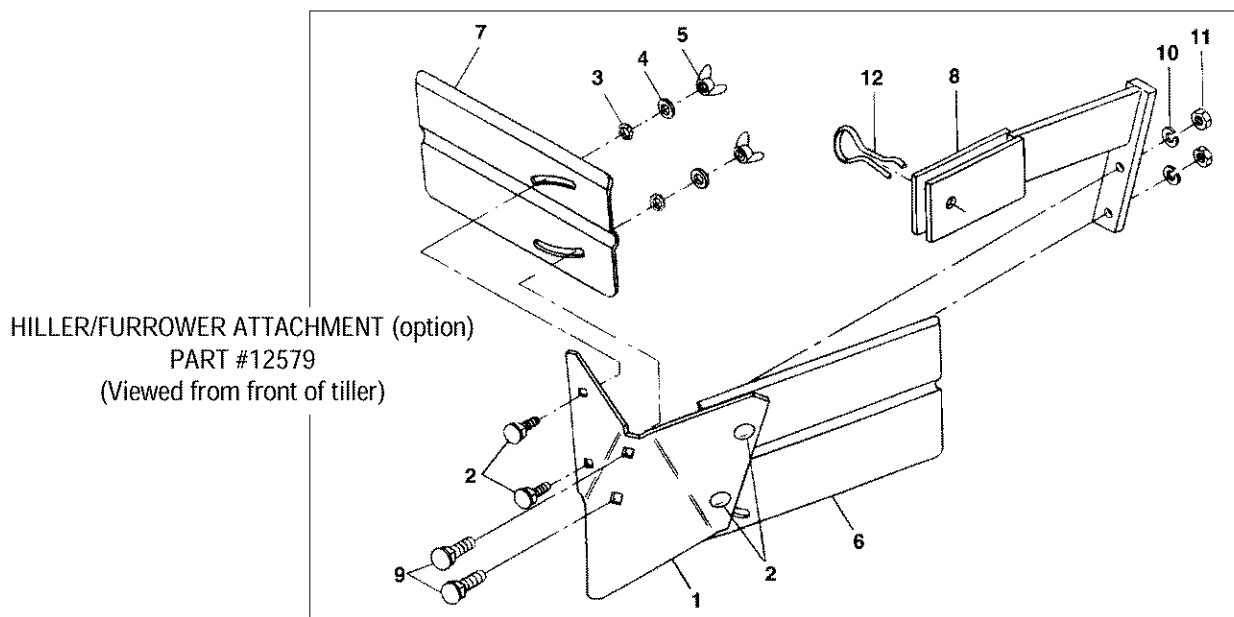
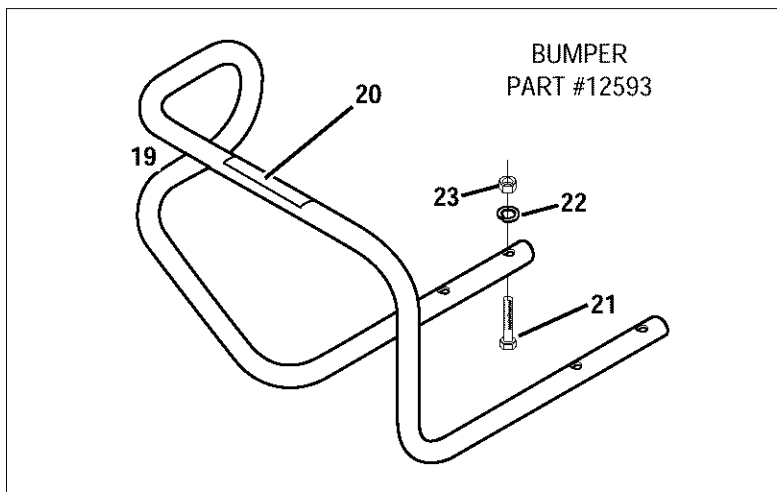
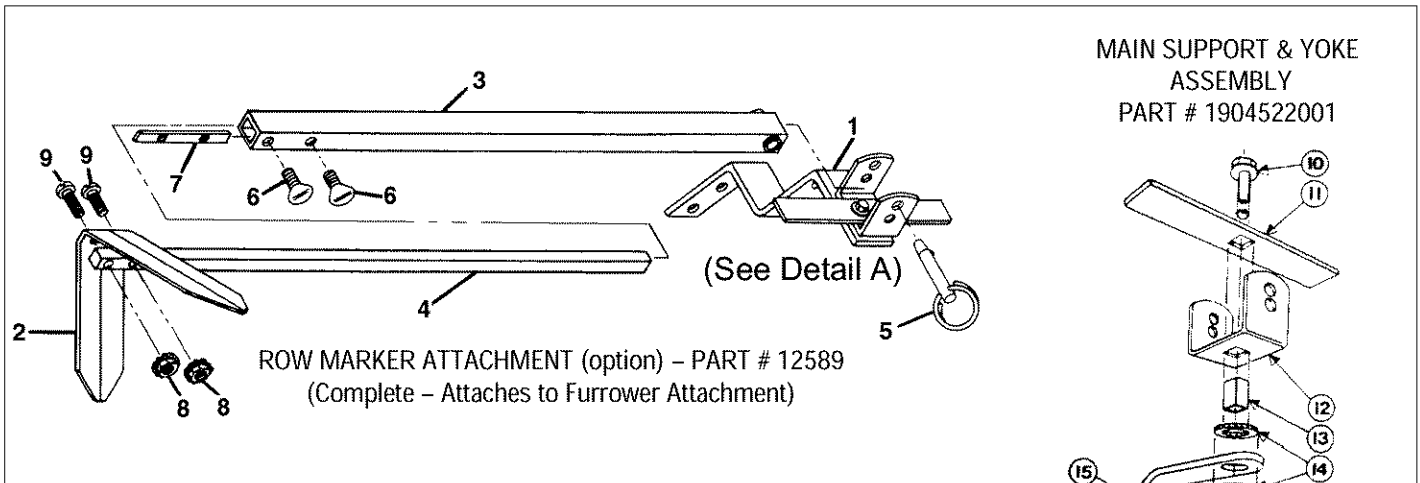





PARTS LIST - DRAWING NO. 7

REF No.	PART No.	DESCRIPTION	QTY.
<b>Row Marker Attachment (option) – Part #12589</b>			
1	1904522001	Main Support & Yoke Assy–complete. Incl. Ref. No.'s 10,11,12,13,14,15,16,17 & 18 .....	1
2	1594	Marker Blade–blade only .....	1
3	1904524001	Marker Arm–main arm .....	1
4	1904523001	Marker Arm–extension arm with stop pin .....	1
5	9347	Hitch Pin–(incl. in Hardware Pkg #1837) .....	1
6	9786	Thumbscrew–1/4-20 x 1/2, not avail. sep. (see hardware pkg. #1837) .....	2
7	1596	Nut Bar–(incl. in hardware pkg #1837) .....	1
8	9828	Nut–hex, 10-24 w/attached start washers, not avail. sep. (see hardware pkg #1837) .....	2
9	1100135	Screw–round hd., 10-24 x 1, not avail. sep. (see hardware pkg #1837) .....	2
---	1837	Hardware Package–includes: one #9347 hitch pin (Ref. 5), two #9786 thumbscrews (Ref. 6), one #1596 nut bar (Ref. 7), two #9828 hex nuts (Ref. 8), two 1100135screws (Ref. 9) .....	1
---	12582	Row Marker Attachment & Pony Hiller/Furrower Attachment – complete: incl. #12579 Pony Hiller/Furrower and #12589 Row Marker .....	1
---	12589	Row Marker Attachment – complete: attaches to furrower attachment #12579, includes #1904522001 Main Support & Yoke Assy. ....	1

REF No.	PART No.	DESCRIPTION	QTY.
<b>Row Marker Main Support &amp; Yoke Assembly – Part #1904522001</b>			
10	1186349	Screw–hex flanged locking, 3/8-16 x 1-1/2* .....	1
11	1593	Stop Bar .....	1
12	1592	Yoke .....	1
13	1591	Tube Key–square .....	1
14	1590	Washer–friction .....	2
15	1588	Main Support .....	1
16	1589	Washer–square hole .....	1
17	9925	Washer–disc spring .....	1
18	1186231	Nut–hex 3/8-16 .....	1
<b>Bumper – Part #12593</b>			
19	1918749001	Bumper (includes Ref. 20) .....	1
20	1448	Decal - Caution .....	1
21	1111607	Screw–hex hd., 5/16-18 x 2-1/4*, not avail. separately (order #1918781 hardware kit) ..	4
22	1100242	Lockwasher–5/16*, not avail. separately (order #1918781 hardware kit) .....	4
23	1186230	Nut–hex, 5/16-18*, not avail. separately (order #1918781 hardware kit) .....	4
---	1918781	Hardware Kit: Incl. four each of Refs. 21, 22 and 23 .....	1
<b>Hiller/Furrower Attachment (option) – Part #12579</b>			
1	1900771001	Furrower–blade only .....	1
2	1186098	Carriage Screw–5/16-18 x 3/4 .....	4
3	1177548	Star Washer–external tooth, 5/16 .....	4
4	9902	Plain Washer–5/16 S.A.E. ....	4
5	9824	Wing Nut–5/16-18 .....	4
6	1900773001	Hiller Wing–left .....	1
7	1900774001	Hiller Wing–right .....	1
8	1900772001	Bracket–blade mounting .....	1
9	9725	Carriage Screw–blade mounting, 3/8-16 x 1-1/2 .....	2
10	1100243	Lockwasher–3/8, plated .....	2
11	1186231	Nut–hex, 3/8-16, plated .....	2
12	9318	Pin–clinch .....	1
--	12579	Hiller/Furrower–complete attachment (owner must screw blade to mounting bracket, and wings to blade). Instructions included .....	1

Note: Common hardware listed above as "not available separately" can be found at most hardware stores.

\* Specify GRADE 5 if ordering part locally.

DRAWING NO. 8

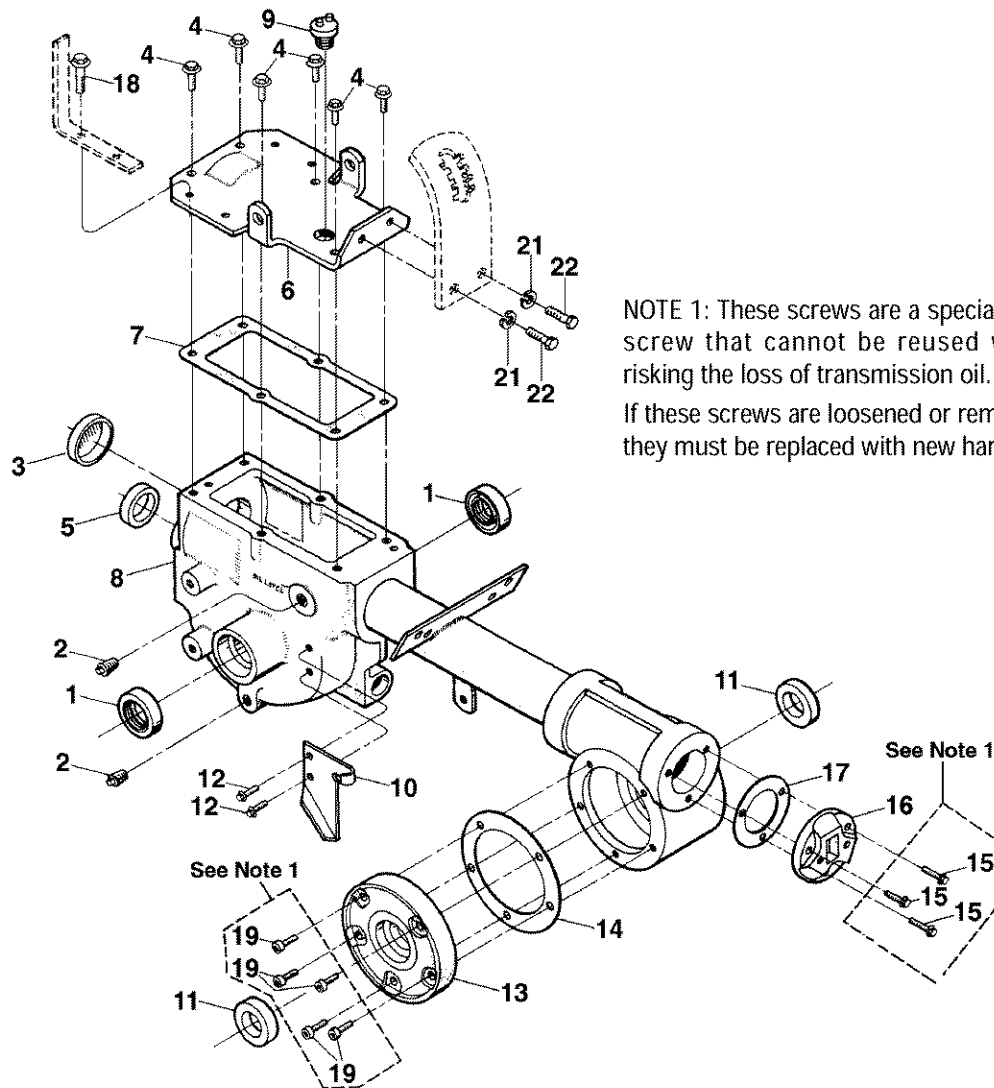

NOTE 1: These screws are a special sealing screw that cannot be reused without risking the loss of transmission oil. If these screws are loosened or removed, they must be replaced with new hardware.

REF No.	PART No.	DESCRIPTION	QTY.	REF No.	PART No.	DESCRIPTION	QTY.
1	9621	Oil Seal—double lip, wheel shaft.....	2	11	97073	Oil Seal—tiller shaft.....	2
2	9726	Pipe Plug, 1/4.....	2	12	90038	Screw—flanged hex hd., 5/16-18 x 5/8*.....	2
3	97076	Seal—Transmission bore.....	1	13	20873	Cover—tiller housing, left-side.....	1
4	1186329	Screw—flanged hex hd., 5/16-18 x 3/4*.....	6	14	1129-1	Gasket—tiller housing cover, .010.....	A/R
5	85030	Oil Seal—input pinion shaft.....	1	15	1915089	Screw Kit: includes three (3) 1/4-20 x 7/8 self-sealing screws.....	A/R
6	11513	Cover—Top of transmission (incl. four of Ref. No. 18 and two each of Ref. No.'s 21 and 22).....	1	16	1115	Cap—Rear bearing.....	1
7	20694	Gasket—Transmission top cover.....	1	17	1124-2	Gasket—Rear bearing cap, .010 thick.....	A/R
8	20893	Transmission case, tube and rear housing assembly.....	1	18	1186331	Screw—flanged hex hd., 5/16-18 x 1*.....	4
9	9467	Plug—gear oil fill hole.....	1	19	1915087	Screw Kit: includes five (5) 1/4-20 x 5/8 self-sealing screws.....	A/R
10	20889	Plate—wheel drive cable mounting.....	1	21	1100243	Lockwasher, 3/8.....	2
				22	1100068	Hex Hd. Screw, 3/8-16 x 3/4*.....	2

\* Specify GRADE 5 if ordering part locally.

A/R – As Required



# NOTES

---

# CUSTOMER SERVICE INFORMATION

## Owner Registration Card

Please fill out and mail the enclosed owner registration card. The purpose of this card is to register each unit at the Factory so that we can provide you with warranty benefits and informational bulletins.

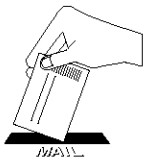

## Warranty Service

The warranty statement is included in the unit's literature package.

## Model/Serial Numbers

A Model/Serial Numbers decal is located on top of the transmission. For ready reference, record these numbers in the spaces below.

Date of Purchase: \_\_\_\_\_

Model Number: \_\_\_\_\_

Serial Number: \_\_\_\_\_

## Authorized Dealer Information

If you purchased your unit from an authorized dealer, record the dealer's address and phone number below for ready reference:

Dealer Name: \_\_\_\_\_

Address: \_\_\_\_\_

Phone: \_\_\_\_\_

### IMPORTANT:

**Left and right sides of the unit are determined by standing behind the unit, in the operator's position, and facing in the direction of forward travel.**

### NOTICE:

**We reserve the right to change specifications, add improvements or discontinue the manufacture of any of our equipment without notice or obligation to purchasers of our equipment.**

## Customer Service and Technical Service

If you have questions or problems with the unit, contact your local dealer or the Factory. (When calling or writing, provide the Model/Serial Numbers of the unit.)

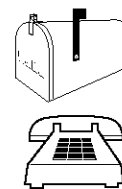

## Replacement Parts

Factory specified replacement parts are available from your authorized dealer or directly from the factory. When ordering parts, be sure to provide the following:

- Model/Serial Numbers of the unit.
- Part number of the part needed.
- Part Description.
- Quantity needed.

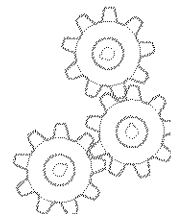

NOTE: All replacement parts must conform to our rigid quality specifications. Although some replacement parts we provide may vary slightly in shape, color or texture from the original parts, any variations will not affect the fit or performance of these parts on your unit.

## Engine Service and Repair

For engine service or repair, contact your nearest authorized engine dealer (look in the Yellow Pages under "Engines-Gasoline"). The engine is warranted by the engine manufacturer. Any unauthorized work performed on the engine during the warranty period may void this warranty. For complete details on the engine warranty, refer to the engine owner manual.

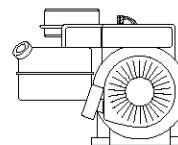

### **⚠ WARNING**

**We urge using only genuine replacement parts, which meet all the latest requirements. Replacement parts manufactured by others could present safety hazards, even though they may fit on the unit.**

*For customer assistance, contact your nearest authorized dealer or:*

**GARDEN WAY INCORPORATED** • 1 Garden Way • Troy, New York 12180  
Customer Service: 1-800-437-8686 • Technical Service: 1-800-520-5520 • Parts Service: 1-800-648-6776  
• FAX: (518) 233-4622 • WEBSITE: [www.troybilt.com](http://www.troybilt.com)

Outside the United States and Canada:

Customer Service: (518) 233-4807 • Technical Service: (518) 233-4808 • Parts Service: (518) 233-4806 • FAX (518) 233-4622