

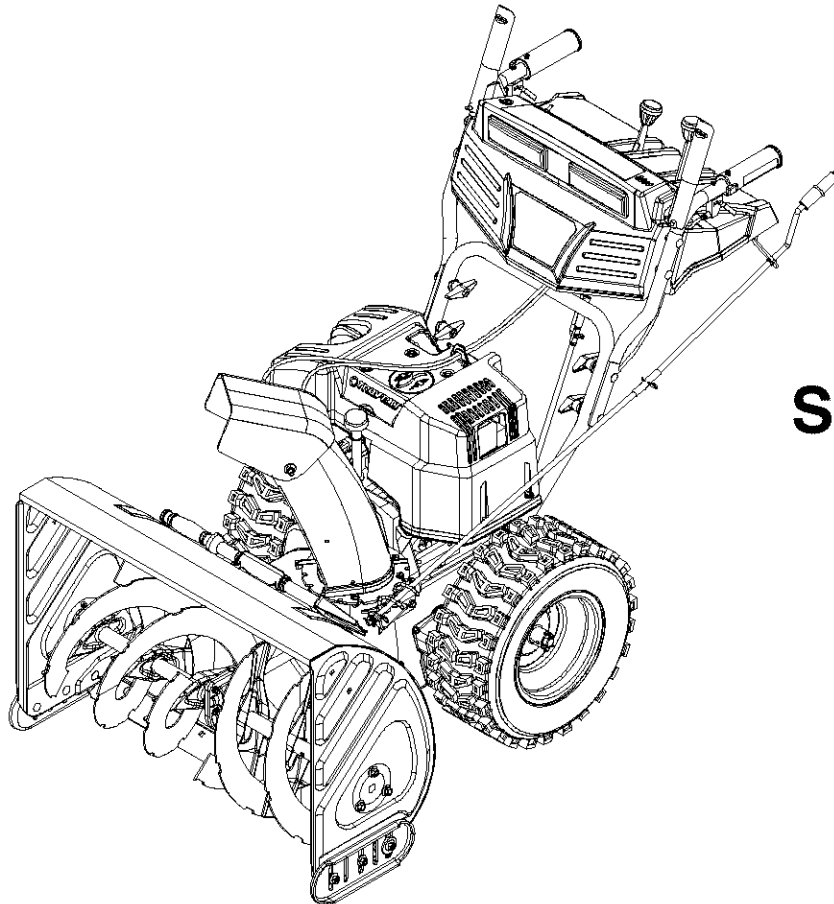

Operator's Manual



Snow Thrower

Model 10030

IMPORTANT: Read safety rules and instructions carefully before operating equipment.

Warning: This unit is equipped with an internal combustion engine and should not be used on or near any unimproved forest-covered, brush-covered or grass-covered land unless the engine's exhaust system is equipped with a spark arrester meeting applicable local or state laws (if any). If a spark arrester is used, it should be maintained in effective working order by the operator. In the State of California the above is required by law (Section 4442 of the California Public Resources Code). Other states may have similar laws. Federal laws apply on federal lands. A spark arrester for the muffler is available through your nearest engine authorized service dealer or contact the service department, P.O. Box 361131 Cleveland, Ohio 44136-0019.

TROY-BILT LLC. P.O. BOX 361131 CLEVELAND, OHIO 44136-0019

PRINTED IN U.S.A.

FORM NO. 769-00376
(6/2002)

TABLE OF CONTENTS

Content	Page
Important Safe Operation Practices	3
Assembling Your Snow Thrower	5
Know Your Snow Thrower	7
Operating Your Snow Thrower.....	9
Making Adjustments.....	11
Maintaining Your Snow Thrower	13
Servicing Your Snow Thrower.....	15
Off-Season Storage	17
Troubleshooting	18
Parts List	20

FINDING MODEL NUMBER

This Operator's Manual is an important part of your new snow thrower. It will help you to assemble, prepare and maintain the unit for best performance. Please read and understand what it says.



Before you start assembling your new snow thrower, please locate the model plate on the equipment and copy the information from it in the space provided below. The information on the model plate is very important if you need help from our Customer Support Department or an authorized dealer.

You can locate the model number by standing behind the unit in the operating position and looking down at the dash panel . A sample model plate is explained below. For future reference, please copy the model number and the serial number of the equipment in the space below.



Copy the model number here: _____

Copy the serial number here: _____

ENGINE INFORMATION

The engine manufacturer is responsible for all engine-related issues with regards to performance, power-rating, specifications, warranty and service. Please refer to the engine manufacturer's Owner's/Operator's Manual packed separately with your unit for more information.

CALLING CUSTOMER SUPPORT

Please do NOT return the unit to the retailer from which it was purchased, without first contacting Customer Support.



If you have difficulty assembling this product or have any questions regarding the controls, operation or maintenance of this unit, please call **1-866-840-6483** or **1-330-558-7220** to reach a Customer Support representative. Please have your unit's model number and serial number ready when you call. See previous section to locate this information. You will be asked to enter the serial number in order to process your call.

For more details about your unit, visit our website at www.troybilt.com

SECTION 1: IMPORTANT SAFE OPERATION PRACTICES



WARNING: This symbol points out important safety instructions which, if not followed, could endanger the personal safety and/or property of yourself and others. Read and follow all instructions in this manual before attempting to operate this machine. Failure to comply with these instructions may result in personal injury. When you see this symbol—**heed its warning.**



WARNING: Engine Exhaust, some of its constituents, and certain vehicle components contain or emit chemicals known to State of California to cause cancer and birth defects or other reproductive harm.

DANGER: This machine was built to be operated according to the rules for safe operation in this manual. As with any type of power equipment, carelessness or error on the part of the operator can result in serious injury. This machine is capable of amputating hands and feet and throwing objects. Failure to observe the following safety instructions could result in serious injury or death.

Training

1. Read, understand, and follow all instructions on the machine and in the manual(s) before attempting to assemble and operate. Keep this manual in a safe place for future and regular reference and for ordering replacement parts.
 2. Be familiar with all controls and their proper operation. Know how to stop the machine and disengage them quickly.
 3. Never allow children under 14 years old to operate this machine. Children 14 years old and over should read and understand the operation instructions and safety rules in this manual and should be trained and supervised by a parent.
 4. Never allow adults to operate this machine without proper instruction.
 5. Thrown objects can cause serious personal injury. Plan your snow-throwing pattern to avoid discharge of material toward roads, bystanders and the like.
 6. Keep bystanders, helpers, pets and children at least 75 feet from the machine while it is in operation. Stop machine if anyone enters the area.
 7. Exercise caution to avoid slipping or falling, especially when operating in reverse.
7. Never attempt to make any adjustments while engine is running, except where specifically recommended in the operator's manual.
 8. Let engine and machine adjust to outdoor temperature before starting to clear snow.
 9. To avoid personal injury or property damage use extreme care in handling gasoline. Gasoline is extremely flammable and the vapors are explosive. Serious personal injury can occur when gasoline is spilled on yourself or your clothes, which can ignite. Wash your skin and change clothes immediately.
 - a. Use only an approved gasoline container.
 - b. Extinguish all cigarettes, cigars, pipes and other sources of ignition.
 - c. Never fuel machine indoors.
 - d. Never remove gas cap or add fuel while the engine is hot or running.
 - e. Allow engine to cool at least two minutes before refueling.
 - f. Never over fill fuel tank. Fill tank to no more than ½ inch below bottom of filler neck to provide space for fuel expansion.
 - g. Replace gasoline cap and tighten securely.
 - h. If gasoline is spilled, wipe it off the engine and equipment. Move machine to another area. Wait 5 minutes before starting the engine.
 - i. Never store the machine or fuel container inside where there is an open flame, spark or pilot light (e.g. furnace, water heater, space heater, clothes dryer etc.).
 - j. Allow machine to cool at least 5 minutes before storing.

Preparation

1. Thoroughly inspect the area where the equipment is to be used. Remove all doormats, newspapers, sleds, boards, wires and other foreign objects, which could be tripped over or thrown by the auger/impeller.
2. Always wear safety glasses or eye shields during operation and while performing an adjustment or repair to protect your eyes. Thrown objects which ricochet can cause serious injury to the eyes.
3. Do not operate without wearing adequate winter outer garments. Do not wear jewelry, long scarves or other loose clothing, which could become entangled in moving parts. Wear footwear which will improve footing on slippery surfaces.
4. Use a grounded three-wire extension cord and receptacle for all units with electric start engines.
5. Adjust collector housing height to clear gravel or crushed rock surfaces.
6. Disengage all clutch levers before starting the engine.

Operation

1. Do not put hands or feet near rotating parts, in the auger/impeller housing or discharge chute. Contact with the rotating parts can amputate hands and feet.
2. The auger/impeller clutch lever is a safety device. Never bypass its operation. Doing so makes the machine unsafe and may cause personal injury.
3. The clutch levers must operate easily in both directions and automatically return to the disengaged position when released.
4. Never operate with a missing or damaged discharge chute. Keep all safety devices in place and working.

5. Never run an engine indoors or in a poorly ventilated area. Engine exhaust contains carbon monoxide, an odorless and deadly gas.
6. Do not operate machine while under the influence of alcohol or drugs.
7. Muffler and engine become hot and can cause a burn. Do not touch.
8. Exercise extreme caution when operating on or crossing gravel surfaces. Stay alert for hidden hazards or traffic.
9. Exercise caution when changing direction and while operating on slopes.
10. Plan your snow-throwing pattern to avoid discharge towards windows, walls, cars etc. Thus, avoiding possible property damage or personal injury caused by a ricochet.
11. Never direct discharge at children, bystanders and pets or allow anyone in front of the machine.
12. Do not overload machine capacity by attempting to clear snow at too fast of a rate.
13. Never operate this machine without good visibility or light. Always be sure of your footing and keep a firm hold on the handles. Walk, never run.
14. Disengage power to the auger/impeller when transporting or not in use.
15. Never operate machine at high transport speeds on slippery surfaces. Look down and behind and use care when in reverse.
16. If the machine should start to vibrate abnormally, stop the engine, disconnect the spark plug wire and ground it against the engine. Inspect thoroughly for damage. Repair any damage before starting and operating.
17. Disengage all clutch levers and stop engine before you leave the operating position (behind the handles). Wait until the auger/impeller comes to a complete stop before unclogging the discharge chute, making any adjustments, or inspections.
18. Never put your hand in the discharge or collector openings. Always use the clean-tool provided to unclog the discharge opening. Do not unclog discharge chute while engine is running. Before unclogging, shut off engine and remain behind handles until all moving parts have stopped completely.
19. Use only attachments and accessories approved by the manufacturer (e.g. wheel weights, tire chains, cabs etc.).
20. If situations occur which are not covered in this manual, use care and good judgment. Contact your dealer or

telephone 1-800-800-7310 for assistance and the name of your nearest servicing dealer.

Maintenance & Storage

1. Never tamper with safety devices. Check their proper operation regularly. Refer to the maintenance and adjustment sections of this manual.
2. Before cleaning, repairing, or inspecting machine disengage all clutch levers and stop engine. Wait until the auger/impeller come to a complete stop. Disconnect the spark plug wire and ground against the engine to prevent unintended starting.
3. Check bolts and screws for proper tightness at frequent intervals to keep the machine in safe working condition. Also, visually inspect machine for any damage.
4. Do not change the engine governor setting or over-speed the engine. The governor controls the maximum safe operating speed of the engine.
5. Snow thrower shave plates and skid shoes are subject to wear and damage. For your safety protection, frequently check all components and replace with original equipment manufacturer's (OEM) parts only. "Use of parts which do not meet the original equipment specifications may lead to improper performance and compromise safety!"
6. Check clutch controls periodically to verify they engage and disengage properly and adjust, if necessary. Refer to the adjustment section in this operator's manual for instructions.
7. Maintain/replace safety/instruction labels, as necessary.
8. Observe proper disposal laws and regulations for gas, oil, etc. to protect the environment.
9. Prior to storing, run machine a few minutes to clear snow from machine and prevent freeze up of auger/impeller.
10. Never store the machine or fuel container inside where there is an open flame, spark or pilot light such as a water heater, furnace, clothes dryer etc.
11. Always refer to the operator's manual for proper instructions on off-season storage.

Your Responsibility

Restrict the use of this power machine to persons who read, understand and follow the warnings and instructions in this manual and on the machine. The safety labels are shown below for your reference.

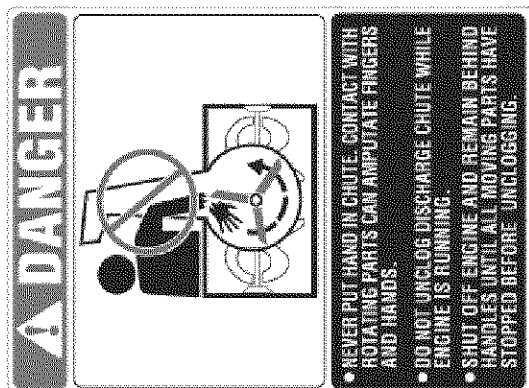

SECTION 2: ASSEMBLING YOUR SNOW THROWER

Unpacking

- Remove staples from the top, sides, and ends of the shipping crate.
- Set panels aside to avoid tire punctures or personal injury.
- Remove and discard plastic bag that covers unit.
- Roll the unit out of the crate.
- Check the crate for loose parts before discarding.

Loose Parts

- The augers are secured to the auger shaft with two shear bolts and hex lock nuts. If you hit a foreign object or ice jam, the snow thrower is designed so that the bolts may shear. Two replacement shear bolts and nuts are provided for your convenience. See Figure 1. Store these safely until needed.



Figure 1

IMPORTANT: NEVER replace the auger shear bolts with standard hex bolts. Any damage to the auger gearbox or other components from using standard bolts will not be covered by your snow thrower's warranty.

Items Required For Assembly

1. Pair of pliers
2. Engine oil
3. Fresh gasoline

Before Assembly

- Disconnect spark plug wire and ground it against the engine to prevent unintended starting.

NOTE: All references in this manual to the left or right side of the snow thrower is from the operating position only. Exceptions, if any, will be specified.

Assembling Handle

For shipping purposes, the upper handle is secured loosely to the lower handle with four wing nuts.

- Remove the **lower** plastic wing nut, cupped washer and carriage bolt from each side of the lower handle. See Figure 2.
- Raise the upper handle assembly until it locks over the lower handle.
- Look at the lower rear of the snow thrower frame to be sure all the cables are aligned with the cable

roller guides. Make sure the spring (found at the end of each cable) is attached to its actuator bracket.

- Secure the upper handle and lower handle with the two plastic wing nuts, cupped washers and carriage bolts previously removed. Attach these hardware on the lower hole in the handles. See Figure 2.
- Tighten the two wing nuts already in place on the upper holes and secure the handles firmly. Slide the shift rod connector down over the end of the lower shift rod. Tap the connector until it **locks** over the lower shift rod. See Figure 2.

NOTE: If the connector is not properly assembled, the shift rod will pivot and you will not be able to change speeds or direction of movement.

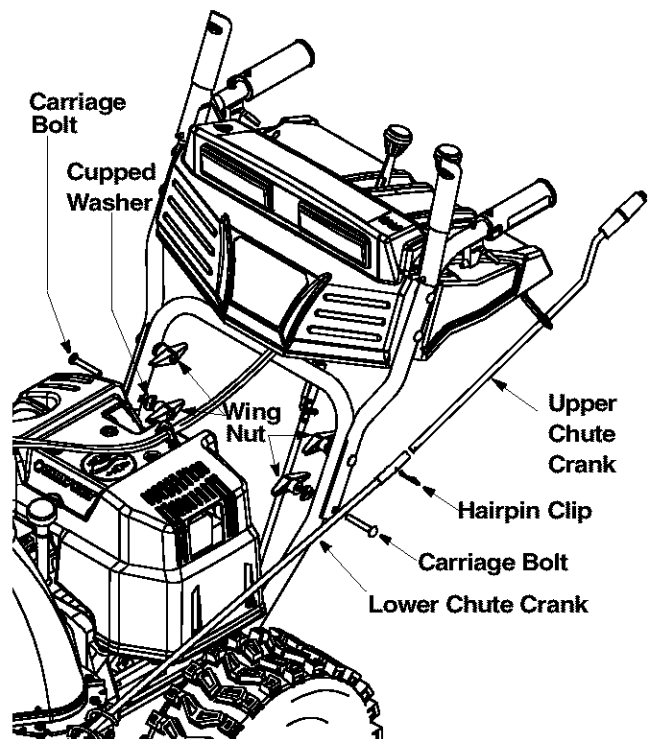

Figure 2

Attaching Chute Crank

- Remove the hairpin clip from the upper chute crank and slide the upper chute crank through the upper chute crank bracket and into the lower chute crank. A pair of pliers may help in this job.
- Align the two holes on both chute cranks and insert the hairpin clip removed earlier, through these holes. See Figure 2.
- If not already attached, slip the cables that run from the handle panel to the discharge chute into the cable guide located on top of the engine. See Figure 3.

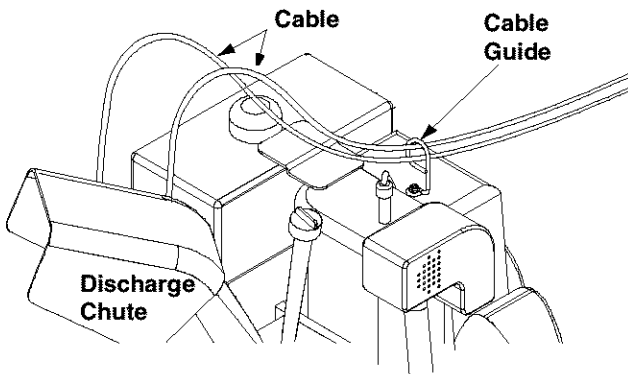
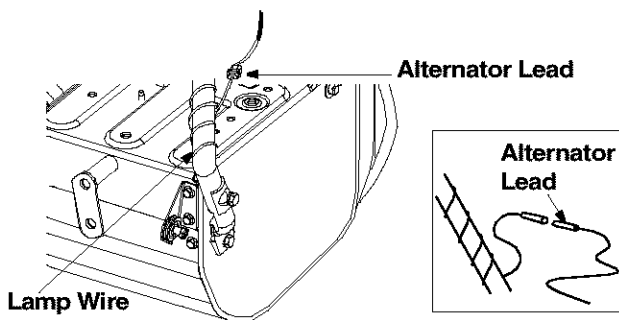

Figure 3

- Unwrap the headlight wire which is attached to the headlight, beneath the handle panel. Wind the headlight wire around the lower right handle until excess slack is removed. See Figure 4.
- Plug the wire from the headlight into the alternator lead coming from the right side of the engine underneath the fuel tank.



NOTE: Wheels are omitted from illustration for clarity.

Figure 4

Chute Clean-Out Tool

- This tool, along with the electric cord, is fastened with a cable tie to the rear of the auger housing for shipping purposes. Cut the cable tie and remove the tool before operating the snow thrower.

Final Adjustments

Make these final adjustments **before** operating your snow thrower for the first time. Failure to follow these instructions may cause damage to the snow thrower.

NOTE: If you have a question about the terms used in these instructions, refer to the descriptions and illustration starting on page 7.

Traction Control & Shift Lever

Perform the following test to determine need for adjustment:

- Move the shift lever into sixth (6) position.

- With the traction control released, push the snow thrower forward, then pull it back. The machine should move freely.
 - Engage the traction control and attempt to move the machine both forward and back, resistance should be felt.
 - Move the shift lever into the fast reverse (R2) position and repeat the previous two steps.
- If you experienced resistance rolling the unit, either when repositioning the shift lever from 6 to R2 or when attempting to move the machine with the traction control released, adjust the traction control immediately. To adjust, proceed as follows:

- Loosen the jam nut on the traction control cable and unthread the cable one full turn.
- Recheck adjustment.
- Retighten the jam nut to secure the cable when correct adjustment is reached.

NOTE: For more details, refer to *Traction Control Adjustment* on page 11.

Auger Control

Check the adjustment of the auger control as follows:

- When the auger control is released and in the disengaged “up” position, the cable should have very little slack, but should NOT be tight.



WARNING: Do not over-tighten the cable.

Over-tightening may prevent the auger from disengaging and compromise the safety of the snow thrower.

- In a well-ventilated area, start the snow thrower engine as instructed on page 9. Make sure the throttle is set in the fast position.
- While standing in the operator’s position (behind the snow thrower) engage the auger.
- Allow the auger to remain engaged for approximately ten (10) seconds before releasing the auger control. Repeat this several times.
- With the engine running in the fast position and the auger control lever in the disengaged “up” position, walk to the front of the machine.
- Confirm that the auger has completely stopped rotating and shows no signs of motion.

IMPORTANT: If the auger shows any signs of rotating, immediately return to the operator’s position and shut off the engine. Wait for all moving parts to stop before readjusting the auger control cable.

- To readjust the control cable, loosen the hex jam nut on the auger control cable “Z” fitting.
- Rotate the coupling end of the cable counterclockwise to provide more slack.
- Retighten the hex jam nut. See Figure 5.
- Repeat Auger Control Test to verify proper adjustment has been achieved..

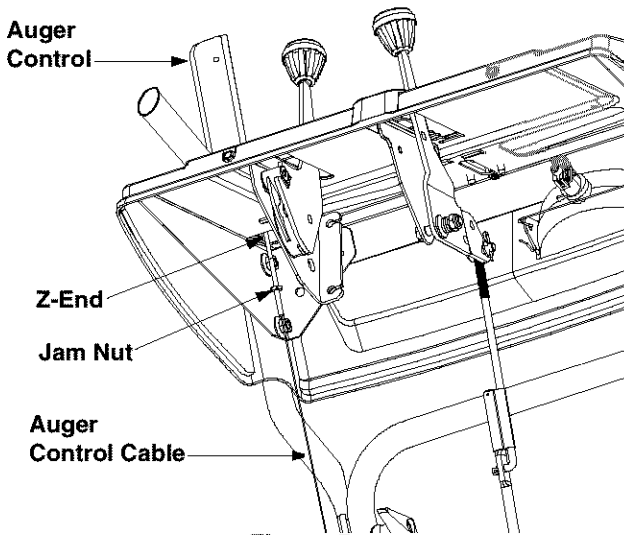

Figure 5

Tire Pressure (Pneumatic Tires)

The tires are overinflated for shipping purposes.

- Check tire pressure. Maintain pressure between 10 and 14 psi.

NOTE: If the tire pressure is not equal in all tires, the unit may pull to one side or the other.



WARNING: Maximum tire pressure under any circumstance is 30 psi. Equal tire pressure should be maintained at all times. Excessive pressure (over 30 psi) when seating beads may cause tire/rim assembly to burst with force sufficient to cause serious injury.

SECTION 3: KNOWING YOUR SNOW THROWER



WARNING: Be familiar with all the controls on the snow thrower and their proper operation. Know how to stop the machine and disengage them quickly.

- Compare the figure below and description of controls in this section with your equipment before starting unit.

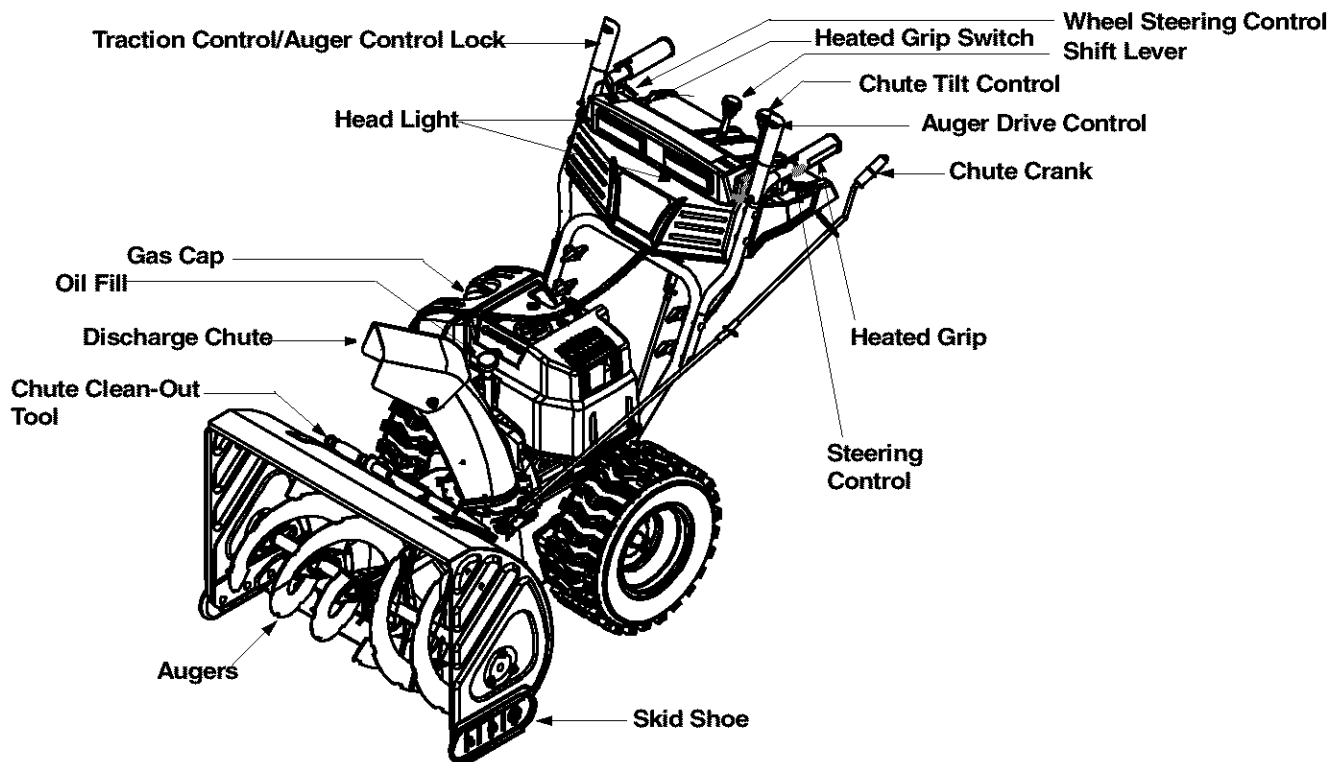

Figure 6

Traction Control / Auger Control Lock

The traction control is located on the right handle. Squeeze the traction control to engage the wheel drive. Release to stop.

This same lever also locks the auger control so you can operate the chute crank without interrupting the snow throwing process. If the auger control is engaged simultaneously with the traction control, the operator can release the auger control (on the left handle) and the augers will remain engaged. Release the traction control to stop the augers and wheel drive (the auger control must also be released).

IMPORTANT: Always release the traction control before changing speeds.

Auger Control

The auger control is located on the left handle. Squeeze the auger control to engage the augers. Release to stop the snow throwing action. The traction control must also be released in order to stop auger.

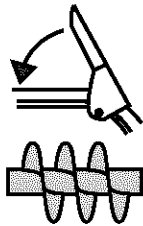

Headlight

The headlight is on whenever the engine is running.

Throttle Control

The throttle control is located on the engine. It regulates the speed of the engine.

Safety Ignition Key

The safety ignition key must be fully inserted in the switch before the unit will start. Remove key when snow thrower is not in use. Do not attempt to turn the key.

Shift Lever

The shift lever is located in the center of the handle panel and is used to determine ground speed and direction of travel. It can be moved into any of eight positions.

IMPORTANT: Always release traction the control before changing speeds.

Forward: The snow thrower has six forward (F) speeds. Position one (1) is the slowest and position six (6) is the fastest.

Reverse: The snow thrower has two reverse (R) speeds—R1 is the slower of the two.

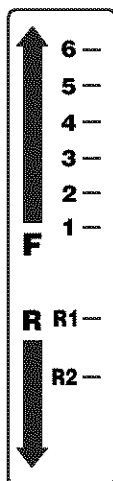

Discharge Chute

The angle of the discharge chute controls the distance that the snow is thrown. Tilt the discharge chute up for greater distance; tilt down for less distance.

Chute Crank

The chute crank is located on the left hand side of the snow thrower. Use it to change the direction in which snow is thrown. Avoid targetting persons, animals or cars and buildings.



Chute Tilt Control

The distance snow is thrown can be changed by adjusting the angle of the chute assembly. Move the chute tilt control forward to decrease the distance, toward the rear to increase.

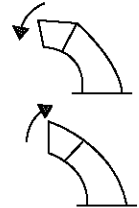

Chute Clean-Out Tool

The chute clean-out tool is designed to clear a clogged discharge chute. Refer to page 10 for instructions on how to properly use it.



WARNING: Never use your hand to clear a clogged discharge chute. Shut off engine and remain behind handles until all moving parts have stopped before unclogging.

Heated Grips Switch

The heated grips switch is located on the right side of the snow thrower handle panel.

- To activate heated grips, toggle the switch to the right to generate heat within the handles. Toggle the switch to the left to the OFF position to deactivate it.

NOTE: The Heated Grips are a compliment to, not a substitute for, proper cold weather outerwear for hands. It is recommended that the user wear adequate winter protection for hands (like gloves/mittens) when operating this snow thrower.

Wheel Steering Controls

The left and right wheel steering controls are located on the underside of the handles.

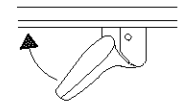

- Squeeze the right control to turn right; squeeze the left control to turn left.

NOTE: Operate the snow thrower in open areas until you are familiar with these controls.

Skid Shoe

The skid shoe position is determined by the condition of the ground from where snow has to be removed. Higher the snow level, lower will be the skid shoe. Adjust it accordingly.

SECTION 4: OPERATING YOUR SNOW THROWER

Before Starting

Read and understand all instructions and warnings on the machine and in this manual **before** operating.

Gas & Oil Fill-Up

- Service the engine with gasoline and oil as instructed in the engine manual shipped with the snow thrower.



WARNING: Use extreme care when handling gasoline. Gasoline is extremely flammable and the vapors are explosive. Never fuel machine indoors or while the engine is hot or running. Extinguish cigarettes, cigars, pipes or other sources of ignition.

- A plastic cap is provided inside the fuel fill opening on the fuel tank. Remove and discard this cap before filling up the tank. Use the separate fuel tank cap to close after fill-up.

To Start Engine

NOTE: *If unit shows any sign of motion (drive or augers) with the clutch grips disengaged, shut engine off immediately. Readjust as instructed in the Final Adjustments in the Assembly Section.*

- Attach spark plug wire to spark plug. Make certain the metal loop on end of the spark plug wire (inside the boot) is fastened securely over the metal tip on the spark plug.
- Make certain the auger and drive clutch levers are in the disengaged (released) position.
- Move throttle control up to FAST position.
- Insert ignition key into slot. Be certain it snaps into place. **Do not turn key.**

NOTE: *Engine will not start unless ignition key is inserted into ignition slot in carburetor cover.*

Electric Starter

- Determine that your house wiring is a three-wire grounded system. Ask a licensed electrician if you are not certain.



WARNING: The electric starter is equipped with a grounded three-wire power cord and plug and is designed to operate on 120 volt AC household current. It must be used with a properly grounded three-prong receptacle at all times to avoid the possibility of electric shock. Follow all instructions carefully prior to operating the electric starter.

- **If your house wiring system is not a three-wire grounded system**, do not use this electric starter under any conditions.
- **If your home electrical system is grounded, but a three-hole receptacle is not available**, one should be installed by a licensed electrician before using the electric starter.
- **If you have a grounded three-prong receptacle**, proceed as follows:
- Rotate choke knob to OFF position and do not prime engine.
- Connect power cord to switch box on engine. Plug the other end of power cord into a three-hole, grounded 120 volt AC receptacle.
- Push starter button on top of the engine to crank engine. As you crank the engine, move choke knob to FULL choke position.
- When engine starts, release starter button, and move choke gradually to OFF. If engine falters, move choke immediately to FULL and then gradually to OFF.
- When disconnecting the power cord, always unplug from the three-prong receptacle first and then from the snow thrower.

Recoil Starter

- Rotate choke knob to FULL choke position (cold engine start). If engine is warm, place choke in OFF position instead of FULL.
- Push primer button two or three times. If engine is warm, push primer button once only.

NOTE: *Always cover vent hole in primer button when pushing. Additional priming may be necessary for first start if temperature is below 15°F.*

- Grasp starter handle and pull rope out slowly, until it pulls slightly harder. Let rope rewind slowly.
- Pull starter handle rapidly. Do not allow handle to snap back. Allow it to rewind slowly while holding firmly. Repeat until engine starts.

To Stop Engine

- Run engine for a few minutes before stopping to help dry off any moisture on the engine.
- To prevent possible freeze-up of starter:
Electric Starter: Connect power cord to switch box on engine, then to 120 volt AC receptacle. With the engine running, push starter button and spin the starter for several seconds. The unusual sound made by spinning the starter will not harm engine or starter. Disconnect the power cord from receptacle first, and then from switch box.

Recoil Starter: With engine running, pull starter rope with a rapid, continuous full arm stroke three or four times. Pulling the starter rope will produce a loud clattering sound, which is normal.

- Move throttle control to “stop” or “off” position.
- Remove ignition key. Do not turn key. Disconnect the spark plug wire from the spark plug to prevent accidental starting while equipment is unattended.

NOTE: *Keep it in a safe place. Engine will not start without ignition key.*

- Wipe all snow and moisture from the carburetor cover in the area of the control levers. Also, move control levers back and forth several times.

To Engage Wheel Drive

- With the engine running near top speed, move the shift lever into one of the six FORWARD positions or two REVERSE positions. Select a speed appropriate for the snow conditions that exist.

NOTE: *Use slower speeds in higher snow, and until you are familiar with the operation of the snow thrower.*

- Squeeze the traction control against the right handle and the snow thrower will move. Release it and the drive motion will stop.

IMPORTANT: NEVER move the shift lever without first releasing the traction control. Doing so will cause premature wear on the drive system’s friction wheel.

To Engage Augers

- To engage augers and start snow throwing, squeeze the auger control against the left handle.
- To disengage power to the augers, release both the auger control and the traction control, if engaged.

The auger control can be locked so you can turn the electric chute directional control without interrupting the snow throwing process.

Operating Tips

NOTE: *Allow the engine to warm up for a few minutes. The engine will not develop full power until it reaches operating temperature.*

- For efficiency in job, remove snow immediately after it falls.



WARNING: The temperature of the muffler and the surrounding areas may exceed 150°F. Avoid these areas.

- Discharge snow downwind whenever possible.
- Slightly overlap each previous path.
- Set the skid shoes 1/4" below the shave plate for normal usage. Adjust it upward for hard-packed snow and downward when using on gravel or crushed rock.

Chute Clean-Out Tool

The chute clean-out tool is conveniently fastened to the rear of the auger housing with a mounting clip. **Never** use your hand to clean a clogged chute or chute opening; use this clean-out tool instead.

- Release both the auger control lever and the traction/auger control lock lever.
- Stop the engine by removing the ignition key.
- Remove the clean-out tool from the clip which secures it to the rear of the auger housing. See Figure 7.
- Use the shovel-shaped end of the clean-out tool to remove any snow and ice in the discharge chute.
- Re-fasten the clean-out tool to the mounting clip on the rear of the auger housing and restart engine.
- While standing in the operator’s position (behind the snow thrower), engage the auger clutch lever for a few seconds to clear any remaining snow or ice from the discharge chute before continuing to clear snow.

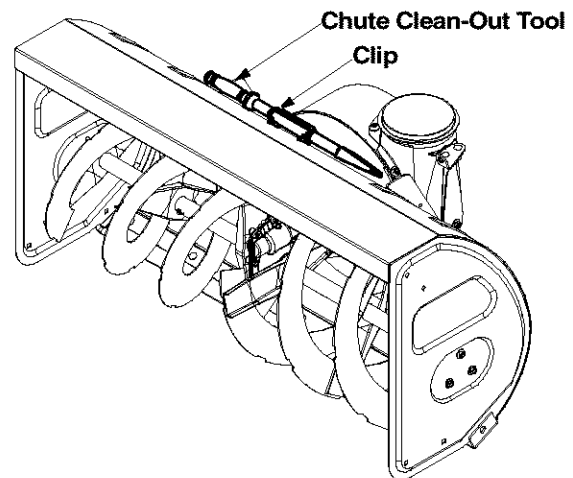

Figure 7

SECTION 5: MAKING ADJUSTMENTS



WARNING: NEVER attempt to clean chute or make any adjustments while engine is running.

Shift Rod

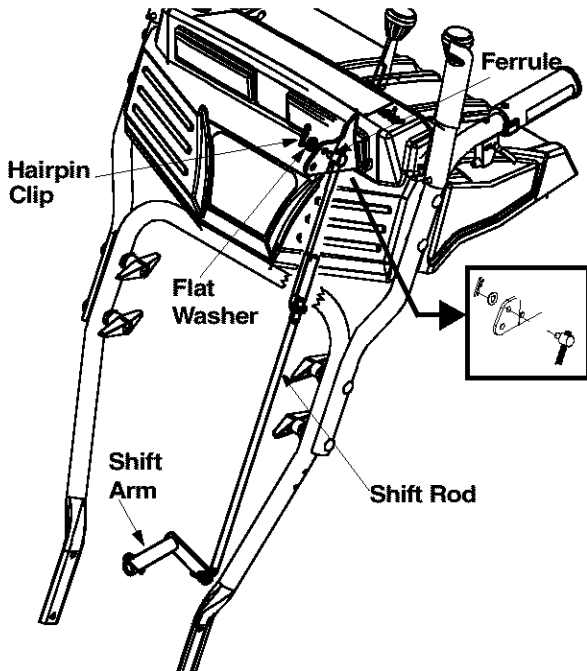

Figure 8

- Remove the hairpin clip and flat washer from the shift handle under the handle panel. See Figure 8.
- Place shift lever in sixth (6) position or fastest forward speed.
- Push shift arm assembly down as far as it will go.
- Rotate the ferrule up or down on the shift rod as necessary until the ferrule lines up with the upper hole in the shift lever. See Figure 8.
- Insert ferrule from the left side of the snow thrower into the upper hole. See Figure 8 inset.
- Reinstall the hairpin clip and the flat washer.

IMPORTANT: Before operating the snow thrower, make sure the shift rod is adjusted according to instructions on page 6.

NOTE: For adjustment of auger control, skid shoe and chute assembly, refer to Final Adjustments in Section 1.

Traction Control

If you are uncertain about correct adjustment, proceed as follows:

- Drain the gasoline out of your snow thrower's engine, and place a piece of plastic film under the gas cap to avoid spillage.

- Tip the snow thrower forward, allowing it to rest on the auger housing. See Figure 9.

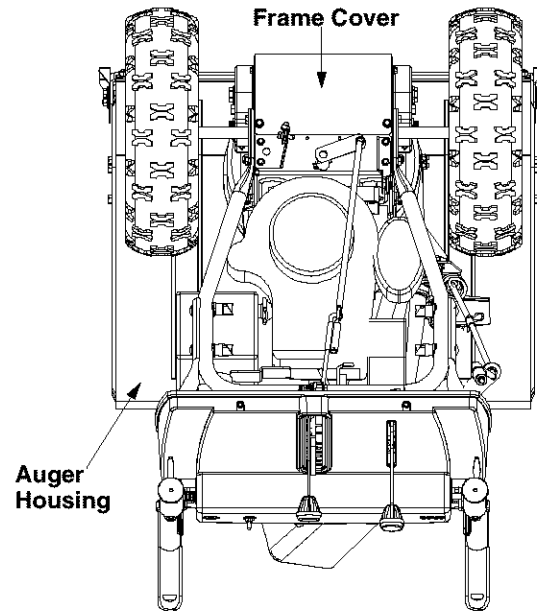

Figure 9

- Remove the frame cover underneath the snow thrower by removing six self-tapping screws.
- With the traction control released, check if there is clearance between friction wheel and drive plate in all positions of the shift lever. See Figure 10.
- With the traction control lever engaged, check if the friction wheel solidly contacts the drive plate. See Figure 10. If not, adjust as follows:
- Loosen the jam nut on the traction drive cable and thread the cable in or out as necessary.
- Retighten the jam nut to secure the cable when correct adjustment is reached.
- Reassemble the frame cover.
- If you placed plastic film under the gas cap earlier, remove it now.

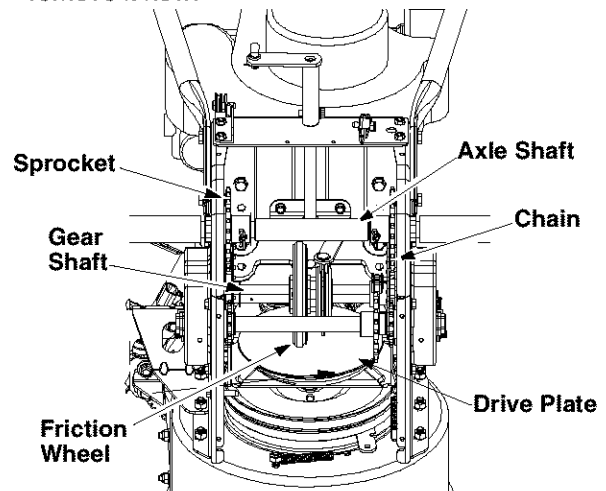

Figure 10

Skid Shoe

The space between the shave plate and the ground can be adjusted by raising or lowering the skid shoes.

For close snow removal, as when using on a smooth concrete or asphalt driveway, place the skid shoes in the low position. Use the middle or high position when the area to be cleared is uneven. When operating on gravel, always put skid shoes in the high position. See Figure 11. Adjust skid shoes as follows:

- Loosen, but do not remove, the three hex nuts which fasten the skid shoe to the auger housing.
- Raise or lower the skid shoe to desired position.
- Retighten the hex nuts loosened earlier.
- Repeat on the other side of the snow thrower.

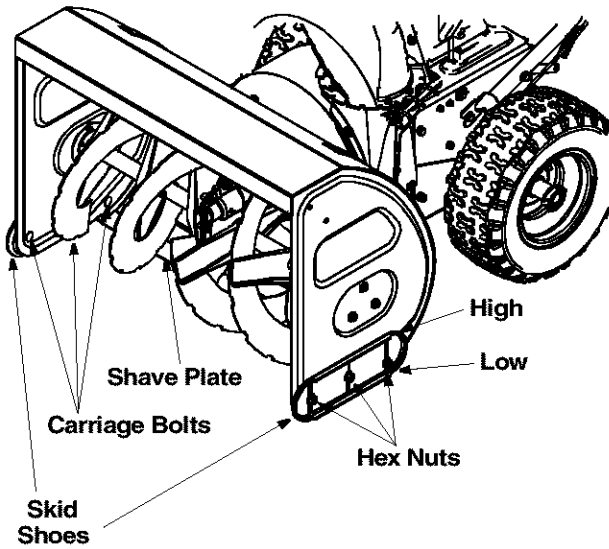

Figure 11

NOTE: Make certain the bottom surface of skid shoe is flat against the ground to avoid uneven wear.

Auger Control

Refer to **Auger Control Test** on page 6 to adjust the auger control. Make certain to check for correct adjustment as instructed before operating the snow thrower.

Chute Assembly

- The distance snow is thrown can be adjusted by adjusting the angle of the chute assembly. Refer to page 8 for instructions.
- The remote chute control cables have been pre-adjusted at the factory. Move the remote chute lever on the control panel back and forward to adjust angle of the chute assembly.

Drive Wheels

- The wheels may be adjusted for two different methods of operation. Follow the steps below for adjustment. See Figure 12.

One Wheel Driving

- On the right side of the unit, place klick pin in the outside axle hole only. Do not place pin through wheel hub. This position gives power drive to the left wheel only, making the unit easier to maneuver.

Both Wheels Driving

- Rotate wheel assembly to align hole in the hub with the inner hole on the axle shaft. Insert klick pin in the hole. Outer axle shaft hole should be visible.

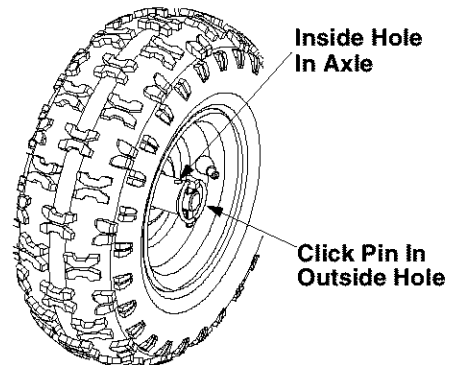

Figure 12

NOTE: NEVER operate the snow thrower with the click pin inserted through both the RIM and the OUTSIDE HOLE in the axle. Doing so can result in serious damage to the drive system.

SECTION 6: MAINTAINING YOUR SNOW THROWER



WARNING: Before lubricating, repairing, or inspecting, disengage all clutch levers and stop engine. Wait until all moving parts have come to a complete stop. Disconnect the spark plug wire and ground it against the engine to prevent unintended starting.

General Recommendations

- Always observe safety rules when performing any maintenance.
- The warranty on this snow thrower does not cover items that have been subjected to operator abuse or negligence. To receive full value from the warranty, operator must maintain the snow thrower as instructed in this manual.
- Some adjustments will have to be made periodically to maintain your unit properly.
- All adjustments in the service and adjustments sections of this manual should be checked at least once each season.
- Periodically check all fasteners and hardware to make sure these are tight.

Lubrication

Drive and Shifting Mechanism

- At least once a season or after every 25 hours of operation, remove rear cover. Lubricate any chains, sprockets, gears, bearings, shafts, and the shifting mechanism at least once a season. Use engine oil or a spray lubricant. Refer to Figure 10.

IMPORTANT: Avoid spillage of oil on rubber friction wheel and aluminum drive plate.

Gear Shaft

- Lubricate the gear shaft with 6-in-1 grease (part number 737-0170) at least once a season, or after every 25 hours of operation. Refer to Figure 10.

IMPORTANT: Keep all grease and oil off the rubber friction wheel and drive plate.

Gear Case

The gear case is lubricated with grease at the factory and it does not require checking.

- If disassembled for any reason, lubricate with 2 ounces of Shell Alvania grease EPR00, part number 737-0168. Before reassembling, remove old sealant and apply new sealant.

IMPORTANT: Do not overfill the gear case, since damage to the seals could result. Be sure the vent plug is free of grease in order to relieve pressure.

Auger Shaft

- At least once a season, remove the shear bolts from the auger shaft and spray lubricant inside the shaft. See Figure 13.

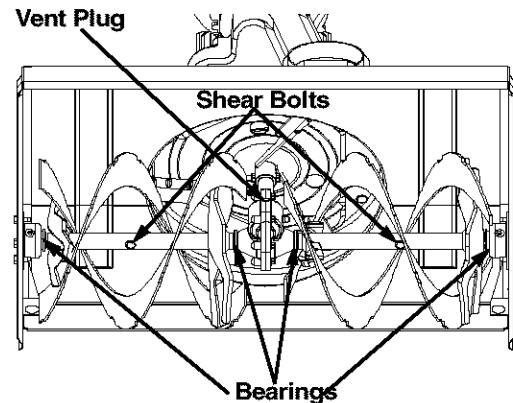

Figure 13

Auger Bearings and Shaft

- Every season lubricate the auger bearings and the bearings on the side of the frame with light oil. See to Figure 13.

Wheels

- Oil or spray lubricant into bearings at wheels at least once a season. Pull klik pin, remove wheels, clean and coat axles with a multipurpose automotive grease. See Figure 14.

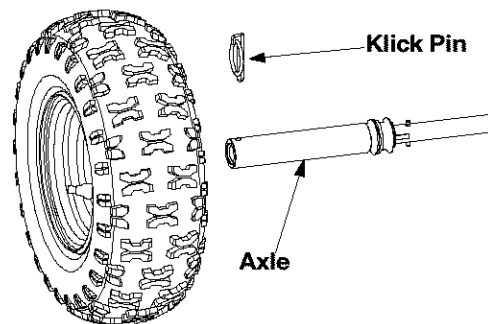

Figure 14

Engine

Refer to the engine manual for instructions.

Discharge Chute

The base of the discharge chute and the spirals on the chute crank should be lubricated at least every 25 hours of use. Apply the lubricant under the base of the chute and where the spirals contact the discharge chute. See Figure 15.

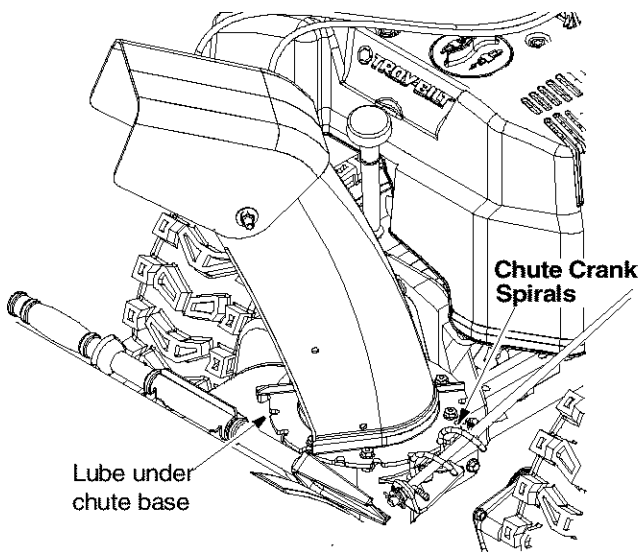

Figure 15

Traction Control / Auger Control Lock

The cams on the ends of the control rods which interlock the traction drive and auger drive clutches must be lubricated at least once a season or every 25 hours of operation using a multi-purpose automotive grease. The cams can be accessed beneath the handle panel. See Figure 16.

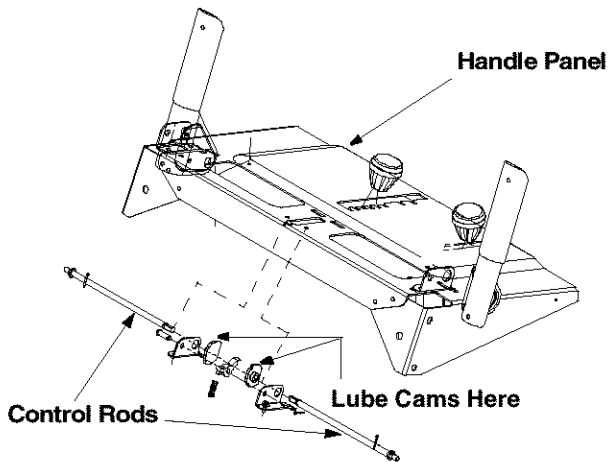

Figure 16

Friction Wheel Rubber

Follow the instructions below to check the condition of the friction wheel rubber every 25 hours of operation.

- Remove the six self-tapping screws from the frame cover underneath the snow thrower.
- Visually inspect the friction wheel rubber for excessive wear, cracks, or loose fit on the friction wheel drive hub.
- Also engage the traction control and check if the friction wheel is making contact with friction plate. Refer to Figure 10. If it does not make contact, adjust the traction drive cable and recheck the friction wheel.
- Replace friction wheel rubber if necessary. Refer to instructions on page 16.

Drive Belts

Check the condition of the drive belts every 50 hours of operation.

- Remove the plastic belt cover on the front of the engine by removing the three self-tapping screws.
- Visually inspect for frayed, cracked, or excessively worn out belts.
- Replace belts as necessary as outlined in Service Section on page 15.

Carburetor



WARNING: If any adjustments are made to the engine while the engine is running (e.g. carburetor), keep clear of all moving parts. Be careful of heated surfaces and mufflers.

Minor carburetor adjustments may be required to compensate for differences in fuel temperature, altitude and load. Refer to the engine manual for instructions.

SECTION 7: SERVICING YOUR SNOW THROWER



WARNING: Before servicing, repairing, or inspecting, disengage all clutch levers and stop engine. Wait until all moving parts have come to a complete stop. Disconnect spark plug wire and ground it against the engine to prevent unintended starting.

Augers

The augers are secured to the spiral shaft with two shear bolts and hex lock nuts. If you hit a foreign object or ice jam, the snow thrower is designed so that the bolts may shear. Refer to Figure 13.

- If the augers do not turn, check if the bolts have sheared. Two replacement shear bolts and hex lock nuts have been provided with the snow thrower. Refer to Loose Parts in the Assembly Section.

IMPORTANT: NEVER replace the auger shear bolts with standard hex bolts. Any damage to the auger gearbox or other components, as a result of doing so, will NOT be covered by your snow thrower's warranty.

Shave Plate and Skid Shoes

The shave plate and skid shoes on the bottom of the snow thrower are subject to wear. These should be checked periodically and replaced when necessary.

NOTE: The skid shoes on this machine have two wear edges. When one side wears out, they can be rotated 180° to use the other edge.

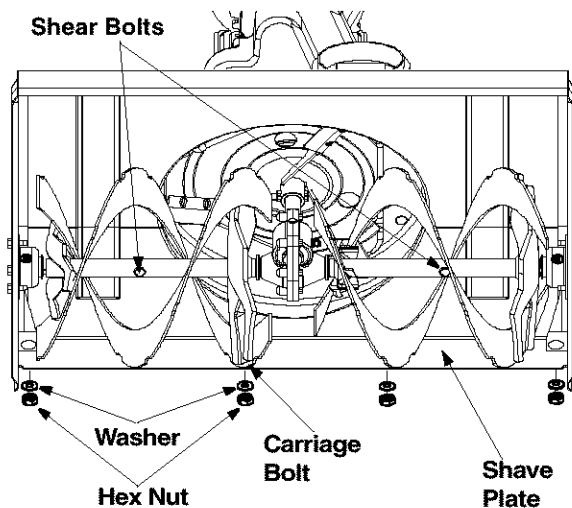

Figure 17

- Remove the six carriage bolts, belleville washers and hex nuts which attach two skid shoes to the snow thrower on two sides. See Figure 11.
- Reassemble new skid shoes with the hardware removed earlier (cupped side of belleville washer

against the skid shoes). Make certain the skid shoes are adjusted to be level.

- To remove the shave plate, remove the carriage bolts, belleville washers and hex nuts which attach the shave plate to the snow thrower housing. See Figure 17.
- Reassemble the new shave plate, with heads of carriage bolts to the inside of the housing. Tighten securely.

Replacing Belts

To remove and replace either the auger belt or the drive belt, follow the steps below and then proceed to the specific steps listed under respective sub-headings.

- Disconnect the chute crank assembly at the discharge chute end by removing the hairpin clip and the two flat washers. See Figure 18A.
- Remove the engine shroud by removing the lock nuts and bolts securing it. See Figure 18B.
- Remove the plastic belt cover, located near the engine, by removing the three self-tapping screws and flat washers that secure it. See Figure 18B.

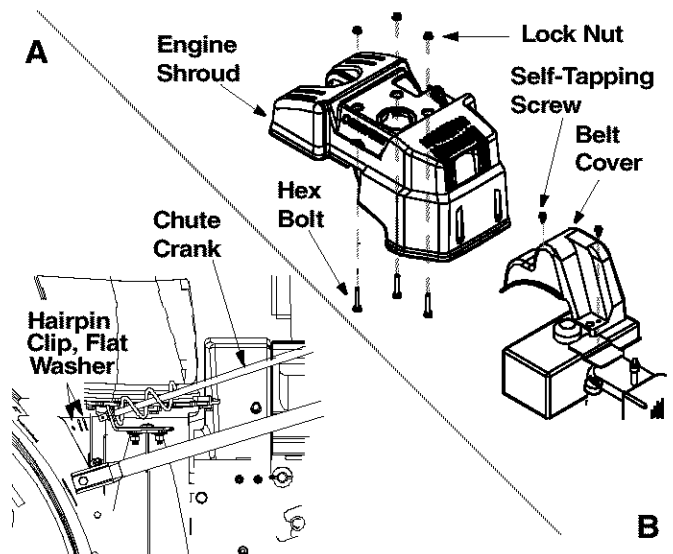

Figure 18

- Tip the snow thrower up and forward so that it rests on its auger housing. Refer to Figure 9.
- Remove the six self-tapping screws from the frame cover underneath the snow thrower.
- Roll the front and rear auger belts off the auger drive pulley. See Figure 19.
- Unhook the idler spring from the hex bolt on the auger housing. See Figure 20.
- Back out the stop bolt until the support bracket rests on the auger pulley.

NOTE: Loosening the six nuts that connect the frame to the auger housing may aid in belt removal.

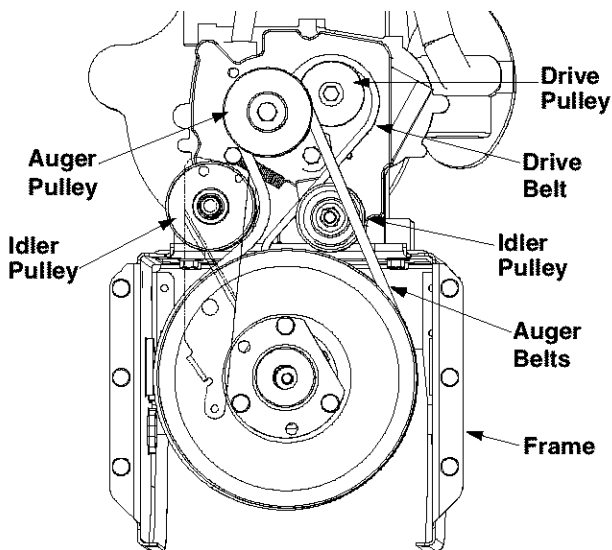

Figure 19

- Lift the rear auger belt from the auger pulley, and slip the belt between the support bracket and the auger pulley. Repeat for the front auger belt. See Figure 20.
- Replace both auger drive belts by following instructions in reverse order.
- If you placed plastic film under the gas cap earlier, remove it now.

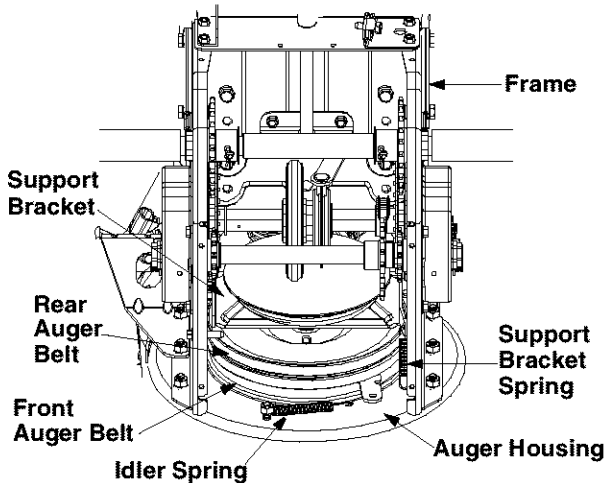

Figure 20

Drive Belt

- Follow the first four steps of the instructions for servicing the auger belts.
- Pull the idler pulley up and lift the belt off the wheel drive pulley and friction wheel disc. See Figure 19.
- Back out the stop bolt until the support bracket rests on the auger pulley. See Figure 21.
- Slip the belt between the friction wheel and drive disc. Remove and replace the belt. Reassemble following the instructions in reverse order.

NOTE: The support bracket must rest on the stop bolt after the new belt has been assembled.

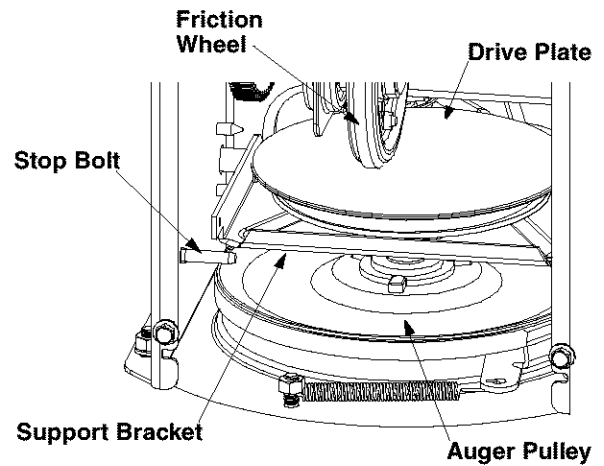

Figure 21

Changing Friction Wheel Rubber

The rubber on the friction wheel is subject to wear and should be checked after the first 25 hours of operation, and periodically thereafter. Replace the friction wheel rubber if any signs of wear or cracking are found.

- Drain the gasoline from the snow thrower, or place a piece of plastic under the gas cap.
- Tip the snow thrower up and forward, so that it rests on the housing.
- Remove the six self-tapping screws from the frame cover underneath the snow thrower.
- Remove the click pin that secures the left wheel to the axle and slide the wheel from the axle.
- Remove the four screws securing the left drive cover to the frame. Remove the drive cover. See Figure 22.

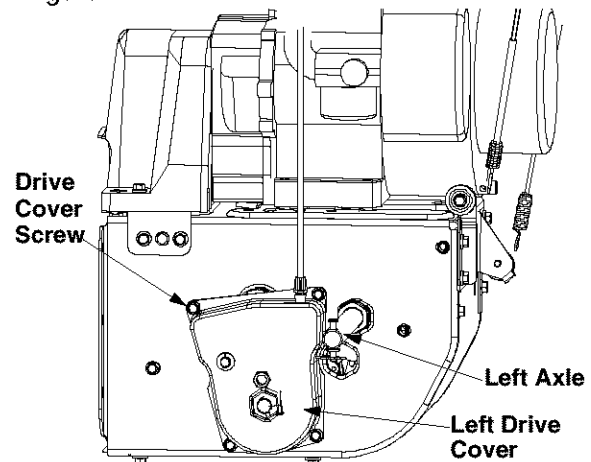

Figure 22

- Holding the friction wheel assembly, slide the hex shaft out of the left side of the frame. The spacer on the right side of the hex shaft will fall and the sprocket should remain hanging loose in the chain. See Figure 23.

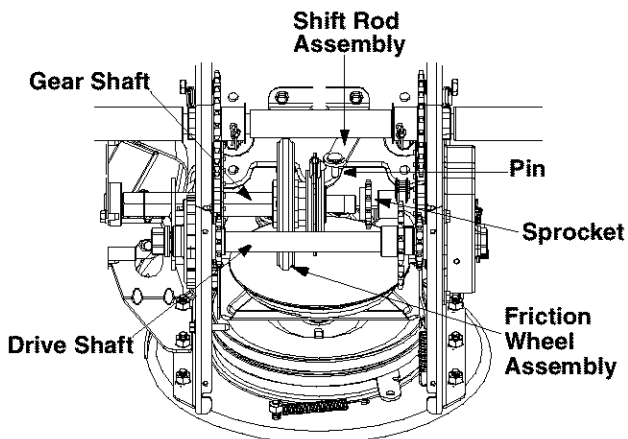

Figure 23

- Lift the friction wheel assembly out between the axle shaft and the drive shaft assemblies.
- Remove the four screws from the friction wheel assembly. Remove the friction wheel rubber from between the friction wheel plates. See Figure 24.

- Reassemble the new friction wheel rubber to the friction wheel plates and hub, tightening the six screws in rotation and with equal force.
- Position the friction wheel assembly up onto the pin of the shift rod assembly, and slide the hex shaft through the friction wheel assembly. Reassemble in reverse order.

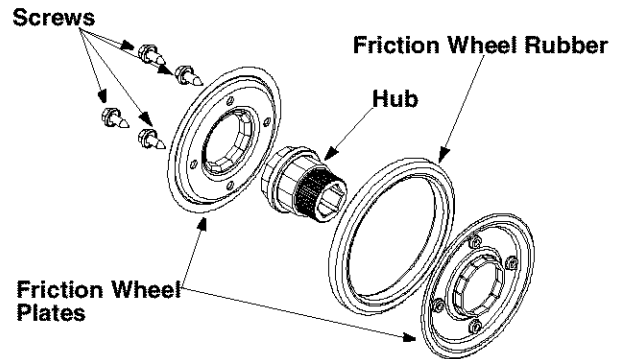

Figure 24

Engine

Refer to separate engine manual for all engine maintenance procedures.

SECTION 8: OFF-SEASON STORAGE



WARNING: Never store engine with fuel in tank indoors or in poorly ventilated areas, where fuel fumes may reach an open flame, spark or pilot light as on a furnace, water heater, clothes dryer or other gas appliance.

- If unit is to be stored over 30 days, prepare engine for storage as instructed in the engine manual.
- Remove all debris from the exterior of equipment.
- Follow lubrication recommendations on page 13.
- Always store the snow thrower in a clean, dry area.

NOTE: When storing any type of power equipment in an unventilated or metal storage shed, care should be taken to rust proof the equipment. Using a light oil or silicone, coat the equipment, especially any chains, springs, bearings and cables.

If unit is to be stored over 30 days, prepare for storage as follows:

- Remove gasoline from carburetor and fuel tank to prevent gum deposits from forming on these parts and causing possible malfunction of engine.



WARNING: Drain fuel into an approved container outdoors, away from an open flame. Allow engine to cool. Extinguish cigarettes, cigars, pipes, and other sources of ignition prior to draining fuel. Fuel left in engine for extended periods deteriorates and will cause starting problems.

- Run engine until fuel tank is empty and engine stops due to lack of fuel.
- Drain carburetor by pressing upward on bowl drain, located below the carburetor cover.

NOTE: Fuel stabilizer is an acceptable alternative in minimizing the formation of fuel gum deposits during storage. Do not drain carburetor if using fuel stabilizer.

- Wipe equipment with an oiled rag to prevent rust.
- Remove spark plug and pour one ounce of engine oil through spark plug hole into cylinder. Cover spark plug hole with rag. Crank engine several times to distribute oil. Replace spark plug.

SECTION 9: TROUBLESHOOTING

Problem	Cause	Remedy
Engine fails to start.	<ol style="list-style-type: none"> 1. Fuel tank empty, or stale fuel. 2. Blocked fuel line. 3. Choke not in ON position 4. Faulty spark plug. 5. Safety key not in ignition switch on engine. 6. Spark plug wire disconnected. 7. Primer button not being used properly. 	<ol style="list-style-type: none"> 1. Fill tank with fresh gasoline. 2. Clean the fuel line. 3. Move switch to ON position 4. Clean, adjust gap or replace. 5. Insert the key fully into the switch. 6. Connect spark plug wire. 7. Refer to the engine manual.
Engine runs erratic.	<ol style="list-style-type: none"> 1. Unit running on CHOKE. 2. Blocked fuel line or stale fuel. 3. Water or dirt in fuel system. 4. Carburetor out of adjustment. 	<ol style="list-style-type: none"> 1. Move choke lever to OFF position. 2. Clean fuel line and fill tank with clean, fresh gasoline. 3. Drain fuel tank and carburetor. Refill with fresh fuel. 4. Refer to the engine manual.
Loss of power.	<ol style="list-style-type: none"> 1. Spark plug wire loose. 2. Gas cap vent hole plugged. 3. Exhaust port plugged. 	<ol style="list-style-type: none"> 1. Connect and tighten spark plug wire. 2. Remove ice and snow from gas cap. Be certain vent hole is clear. 3. Refer to the engine manual.
Engine overheats.	<ol style="list-style-type: none"> 1. Carburetor not adjusted properly. 	<ol style="list-style-type: none"> 1. Refer to the engine manual or have the carburetor adjusted by an authorized engine service dealer.
Excessive vibration.	<ol style="list-style-type: none"> 1. Loose parts or damaged auger. 	<ol style="list-style-type: none"> 1. Stop engine immediately and disconnect spark plug wire. Tighten all bolts and nuts. If vibration continues, have unit serviced by an authorized service dealer.
Unit fails to propel itself.	<ol style="list-style-type: none"> 1. Traction control cable in need of adjustment. 2. Drive belt loose or damaged. 	<ol style="list-style-type: none"> 1. Adjust traction control cable. Refer to Adjustments. 2. Replace drive belt.
Unit fails to discharge snow.	<ol style="list-style-type: none"> 1. Discharge chute clogged. 2. Foreign object lodged in auger. 3. Auger control cable in need of adjustment. 4. Auger belt loose or damaged. 5. Shear bolt(s) sheared. 	<ol style="list-style-type: none"> 1. Stop engine immediately and disconnect spark plug wire. Clean discharge chute and inside of auger housing. 2. Stop engine immediately and disconnect spark plug wire. Remove object from auger. 3. Refer to Final Adjustments in Assembly Section. 4. Refer to Adjustments. 5. Replace shear bolt(s).

NOTE: For repairs beyond minor adjustments listed above, contact the local dealer.

Safety & Decorative Labels

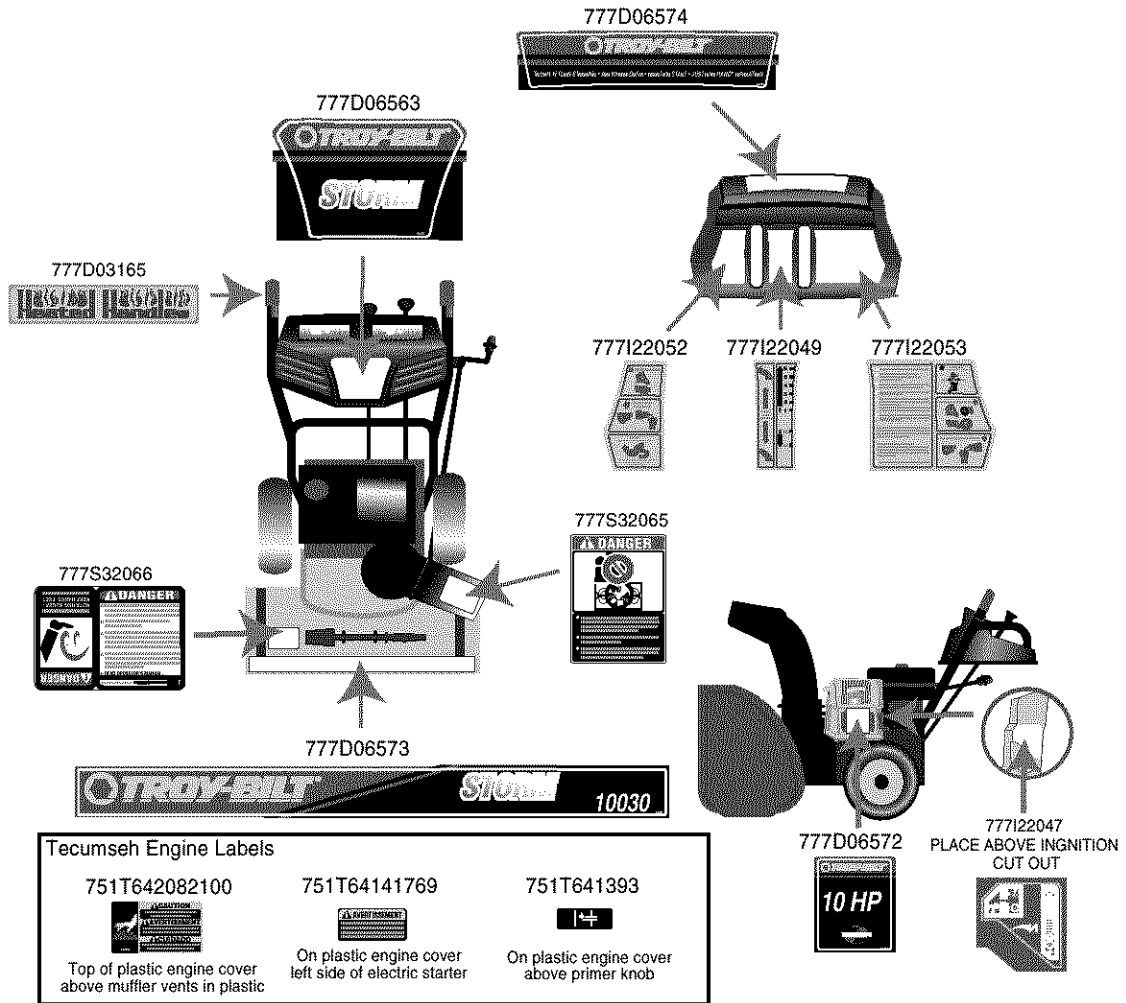

SECTION 10: PARTS LIST FOR MODEL 10030

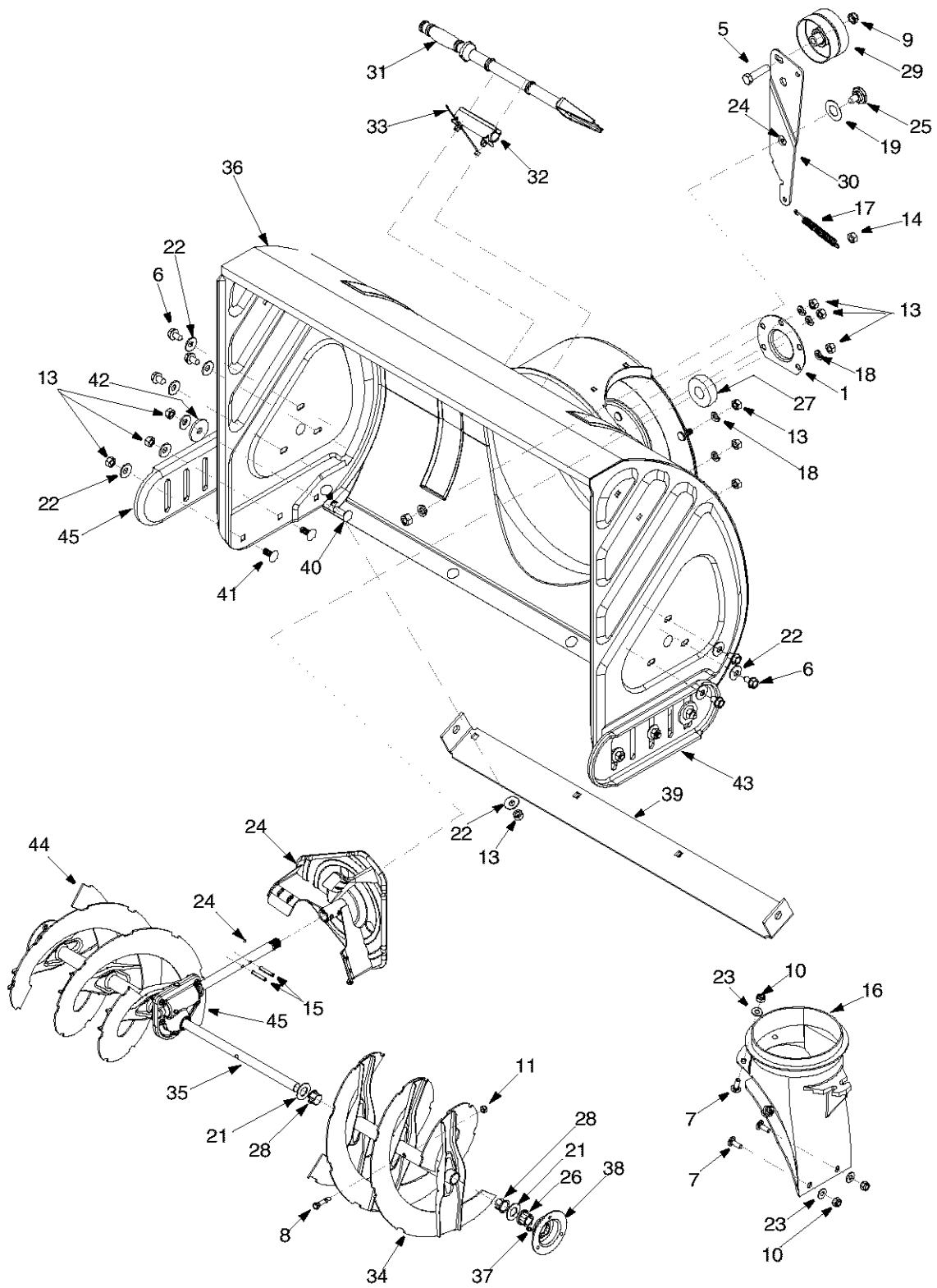

Model 10030

Ref. No.	Part No.	Part Description	Ref. No.	Part No.	Part Description
1.	05931A	Bearing Housing	24.	737-0318	Grease
2.	684-0065	Impeller Assembly	25.	738-0281	Shoulder Screw
3.	705-5226	Chute Reinforcement	26.	741-0245	Hex Flange Bearing
4.	710-0451	Carriage Bolt	27.	741-0309	Ball Bearing
5.	710-0459A	Hex Bolt 3/8-24 x 1.5"	28.	741-0493A	Flange Bearing
6.	710-0604A	TT Screw 5/16-18 x 0.625"	29.	756-0178	Flat Idler
7.	710-0703	Carriage Screw 1/4-20 x 0.75"	30.	784-5632B	Auger Idler Bracket
8.	710-0890A	Shear Bolt	31.	731-2643	Chute Clean-Out Tool
9.	712-0116	Lock Nut 3/8-24	32.	731-2635	Tool Mount
10.	712-0324	Lock Nut 1/4-20	33.	725-0157	Cable Tie
11.	712-0429	Lock Nut	34.	605-5249B	Spiral Assembly LH 30"
12.	712-0798	Hex Nut 3/8-16	35.	618-0417A	Auger Shaft Assembly 30"
13.	712-3010	Hex Nut 5/16-18	36.	684-04004	Auger Housing Assembly
14.	712-3068	Hex Lock Nut	37.	737-3000	Lube Fitting
15.	715-0114	Spring Pin	38.	784-0399	Bearing Housing
16.	731-1379C	Chute Adapter	39.	784-5575	Shave Plate
17.	732-0611	Extension Spring	40.	710-0276	Carriage Screw 5/16-18 x 1.0"
18.	736-0119	Lock Washer	41.	710-0451	Carriage Bolt 5/16-18 x 0.75"
19.	736-0167	Flat Washer	42.	736-0320	Flat Washer .38 x 1.38 x .125
20.	736-0169	Lock Washer	43.	784-5038B	Skid Shoe
21.	736-0188	Flat Washer	44.	605-5248B	Spiral Assembly RH 30"
22.	736-0242	Bell Washer	45.	618-0436	Gear Assembly: Auger
23.	736-0463	Flat Washer			

Model 10030

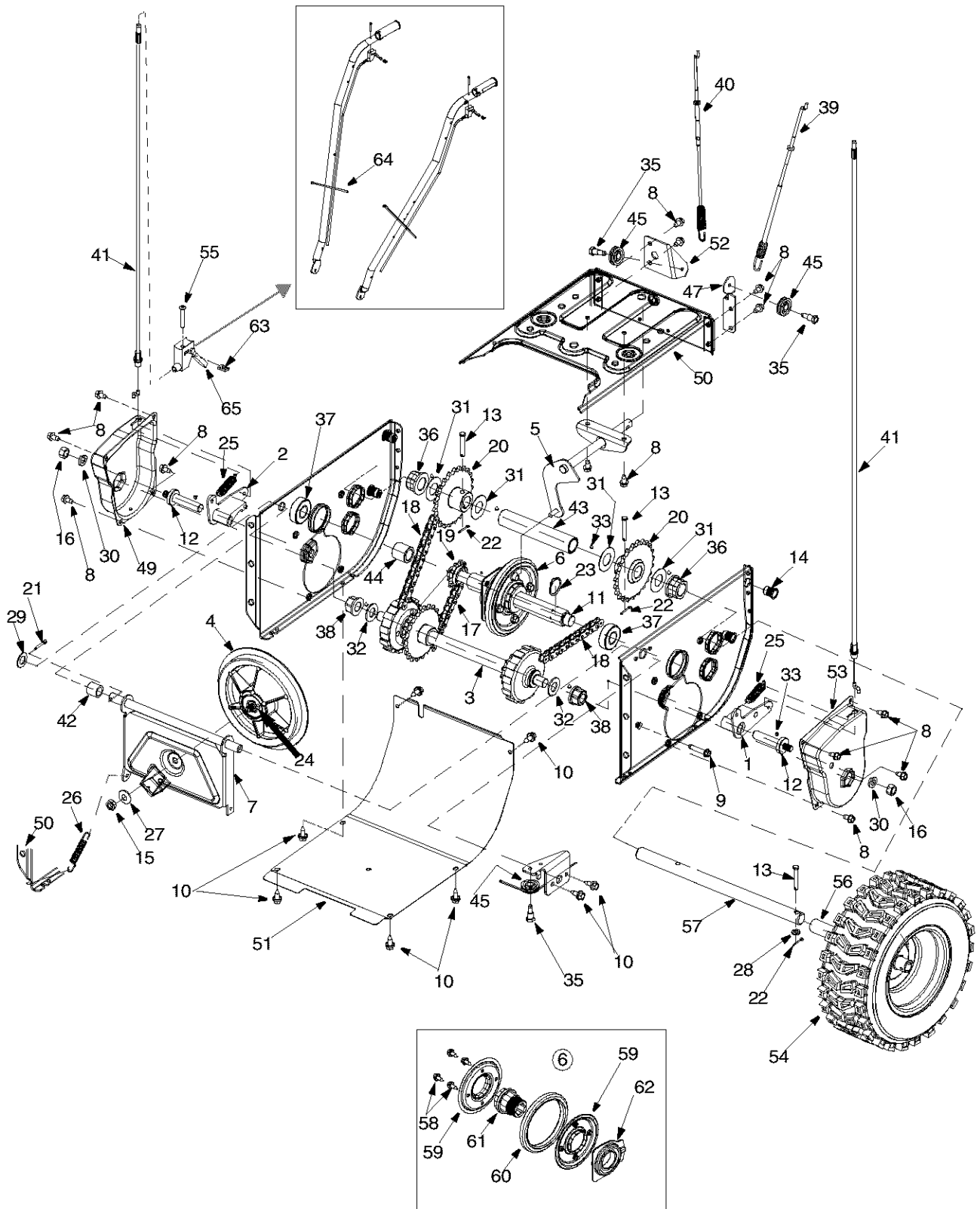

Model 10030

Ref. No.	Part No.	Part Description	Ref. No.	Part No.	Part Description
1.	618-0043	Dogg Assembly RH	34.	737-04027	Lubricant
2.	618-0044	Dogg Assembly LH	35.	738-0924	C Screw 1/4-28 x .375"
3.	618-0575	Drive Shaft	36.	741-0598	Hex Flange Bearing
4.	656-0012A	Friction Wheel Disc Assembly	37.	741-0600	Ball Bearing
5.	684-0014B	Shift Rod Assembly	38.	741-1111	Hex Flange Bearing
6.	684-0042C	Friction Wheel Assembly (includes items 58 to 62)	39.	746-0897	Auger Clutch Cable
7.	684-0131A	Support Bracket	40.	746-0898B	Drive Clutch Cable
8.	710-0599	TT screw 1/4-20 x 0.5"	41.	746-0956	Steering Cable
9.	710-0809	TT Screw 1/4-20 x 1.25"	42.	748-0190	Spacer
10.	710-1652	TT Screw 1/4-20 x .625"	43.	750-1161A	Support Tube: Axle
11.	711-1267	Drive Shaft	44.	750-1162	Spacer
12.	711-1268	Actuator Shaft	45.	756-0625	Cable Roller
13.	711-1364	Clevis Pin	46.	784-5590	Shft Frame Bracket
14.	712-0703A	Nut Insert	47.	784-5687A	Bracket: Auger Clutch Cable Guide
15.	712-0711	Jam Nut	48.	784-5689A	Bracket: Auger Cable Front Support
16.	712-3017	Hex Nut	49.	784-5730A	Shaft Retainer
17.	713-0233	Chain	50.	784-5731B	Frame
18.	713-0374	Chain	51.	784-5732	Frame Cover
19.	713-0413	Sprocket	52.	784-5733	Roller Bracket
20.	713-0472	Sprocket	53.	784-5740	Shaft Retainer
21.	714-0474	Hairpin Clip	54.	634-0227A	Wheel Assembly LH: Complete
22.	714-0474	Hairpin Clip		634-0228A	Wheel Assembly RH: Complete
23.	716-0102	Snap Ring	55.	710-1233	Oval C-Sunk Machine Screw
24.	721-0263	Loctite™	56.	731-04043	Spacer
25.	732-0209	Extension Spring	57.	738-0994A	Axle: Wheel
26.	732-0264	Extension Spring	58.	710-1652	TT Screw 1/4-20 x .625"
27.	736-0105	Bell Washer	59.	784-5617A	Friction Plate
28.	736-0142	Flat Washer	60.	735-0243B	Friction Wheel Rubber
29.	736-0160	Flat Washer	61.	718-0301A	Friction Wheel Hub
30.	736-0169	Lock Washer	62.	618-0063A	Friction Wheel Bearing
31.	736-0351	Flat Washer	63.	712-0127	Weld Nut
32.	736-0626	Flat Washer	64.	725-0157	Cable Tie
33.	737-0318	Loctite™	65.	746-0950	Turn Trigger

Model 10030

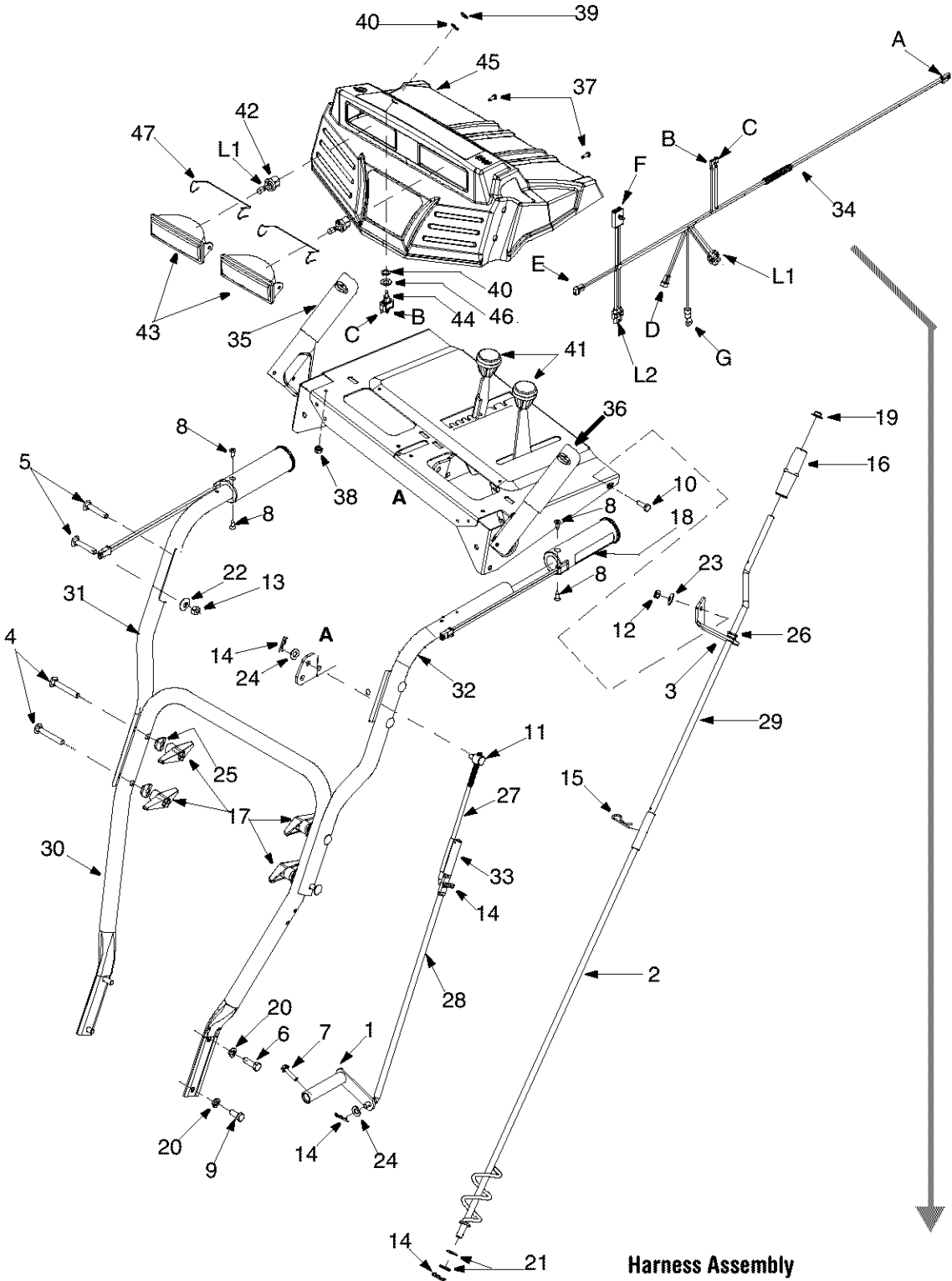

Harness Assembly

Connector	Plugs to:
A	Alternator lead from engine
B, C, L1, L2	Switch and Light 1 and 2
D, E	Heated Grips of handles
F	indicates fuse; G indicates grounding wire.

Model 10030

Ref. No.	Part No.	Part Description
1.	684-0008A	Shift Arm Assembly
2.	684-0053B	Chute Crank assembly
3.	705-5266	Chut Crank Bracket
4.	710-0449	Carriage Screw 5/16-18 x 2.25"
5.	710-0458	Carriage Bolt 5/16-18 x 1.75"
6.	710-0643	Hex Screw 5/16-18 x 1.0"
7.	710-0788	TT Screw 1/4-20 x 1.0"
8.	710-0837	AB Screw
9.	710-1880	Hex Screw 5/16-18 x 0.75"
10.	710-3015	Hex Screw 1/4-20 x 0.75"
11.	711-0677	Ferrule
12.	712-0287	Hex Nut 1/4-20
13.	712-3068	Lock Nut 5/16-18
14.	714-0104	Hairpin Clip
15.	714-0145	Click Pin
16.	720-0201A	Chute Crank Knob
17.	720-0284	Wing Nut
18.	725-1757	Heated Grip
19.	726-0100	Push Cap
20.	736-0119	Lock Washer
21.	736-0185	Flat Washer
22.	736-0242	Bell Washer
23.	736-0270	Bell Washer
24.	736-0275	Flat Washer
25.	736-0451	Saddle Washer
26.	741-0475	Plastic Bushing
27.	747-0620A	Shift Rod: Upper
28.	747-0621	Shift Rod: Lower
29.	747-0737	Chute Crank: Upper
30.	749-0951	Lower Handle
31.	749-0952A	Handle: L Style Fold RH
32.	749-0953A	Handle: L Style Fold LH
33.	750-0963	Connector
34.	629-04007	Harness Assy. (See also table on page 24)
35.	684-0036A	Handle Engagement RH: Black
36.	684-0037B	Handle Engagement LH: Black
37.	710-1003	B Screw #10-16 x 0.625"
38.	712-0271	Sems Nut
39.	712-0693	Hex Nut
40.	716-0398	Toggle Switch
41.	720-0232	Shift Knob
42.	725-1658	Halogen Lamp
43.	725-1672	Lamp Housing
44.	725-1756	Toggle Switch
45.	731-04068	Handle Panel
46.	736-0226	Flat Washer .474 x .879 x .064
47.	747-1136	Headlight Retainer

Model 10030

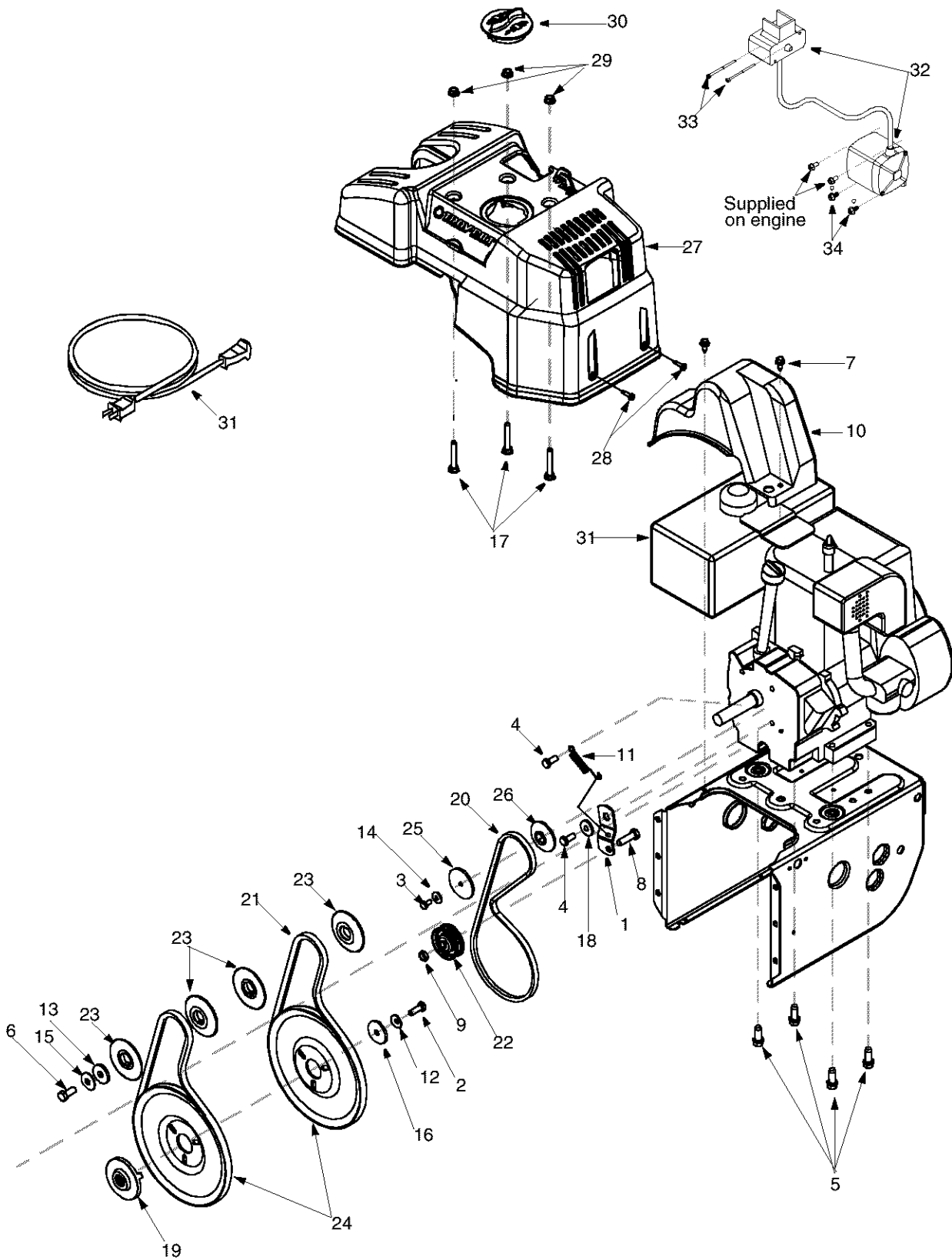

Model 10030

Ref. No.	Part No.	Description
1.	05896A	Idler Bracket: Drive Clutch
2.	710-1245B	Hex Bolt 5/16-24 x .875"
3.	710-0230	Hex Screw 1/4-28 x .50"
4.	710-0627	Hex Screw 5/16-24 x .750"
5.	710-0654A	TT Screw 3/8-16 x 1.0"
6.	710-0696	Hex Screw 3/8-24 x .875"
7.	710-1652	TT Screw 1/4-20 x .625"
8.	710-3005	Hex Screw 3/8-16 x 1.25"
9.	712-0181	Jam Nut
10.	731-1324	Belt Cover
11.	732-0710	Extension Spring
12.	736-0242	Bell Washer
13.	736-0247	Flat Washer .406 x 1.25
14.	736-0270	Bell Washer .265 x .75 x .062
15.	736-0331	Bell Washer .390 x 1.13 x .062
16.	736-0505	Flat Washer .34 x 1.5 x .150
17.		
18.	748-0234	Shoulder Spacer
19.	748-0360	Pulley
20.	754-0346	V-Belt
21.	754-0430B	Belt
22.	756-0313	Flat Idler Pulley
23.	756-0569	Pulley Half
24.	756-0967	Auger Pulley
25.	756-0986	Pulley Half
26.	756-0987	Pulley Half
27.	731-04049	Shroud
28.	710-04082	Hex Screw #10-16 x .75"
29.	712-3004A	Flange Lock Nut 5/16-18
30.	684-04011	Spark Plug Access
31.	629-0071	Extension Cord
32.	7511A173106	Electric Starter
33.	7514289474	Hex Screw #6-32 x 2.5
34.	75142896	Hex Screw 1/4-20 x .500

Model 10030

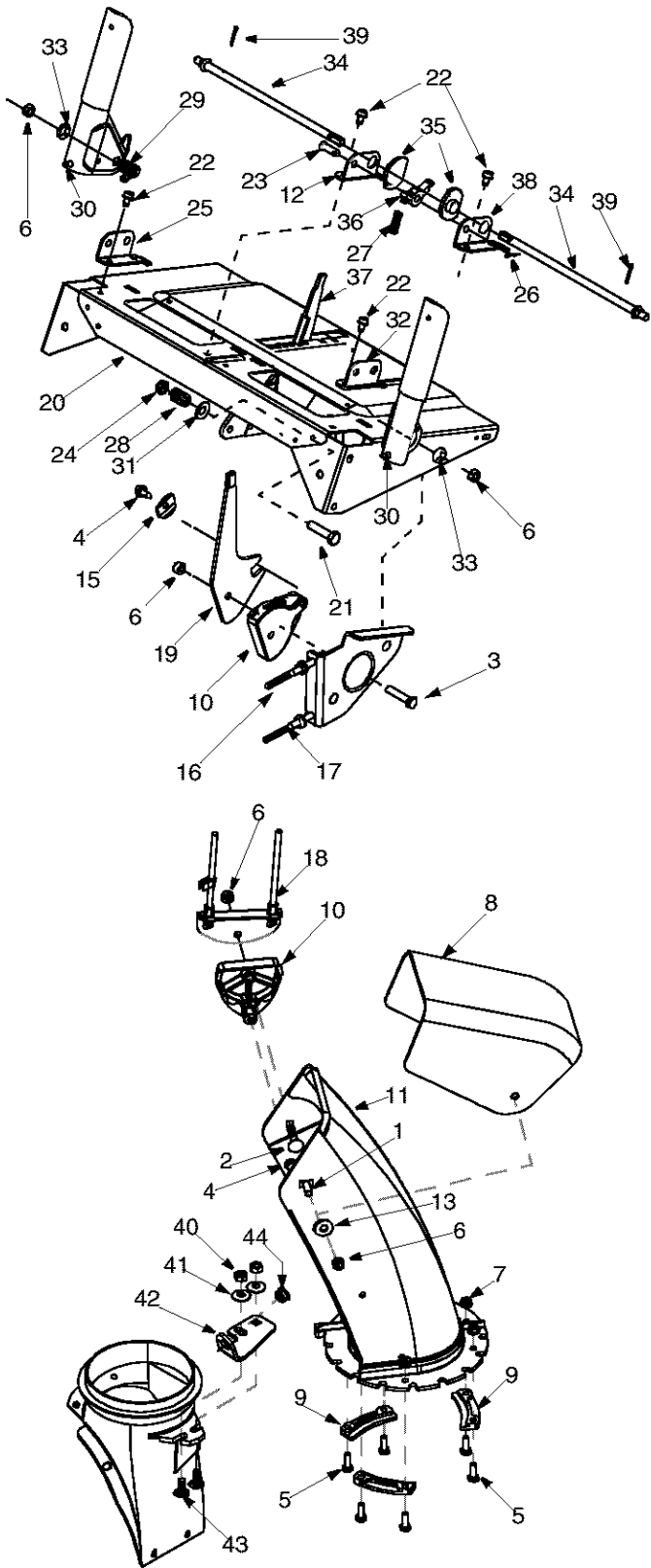

Ref. No.	Part No.	Description
1.	710-04071	Carriage Bolt 5/16-18 x 1.0"
2.	710-0262	Carriage Bolt 5/16-18 x 1.5"
3.	710-0805	Hex Bolt 5/16-18 x 1.5"
4.	710-0896	Hex AB Screw 1/4-14 x .625"
5.	710-3015	Hex Screw 1/4-20 x .75"
6.	712-0429	Hex Lock Nut
7.	712-3027	Hex Flange Lock Nut
8.	731-1320	Upper Chute
9.	731-0851A	Chute Flange Keeper
10.	731-1313C	Cable Guide: Chute Tilt
11.	731-1300B	Lower Chute
12.	784-5680	Handle Suppt. Bracket 5/8 RH
13.	736-0159	5/16 Washer
14.	736-0231	Flat Washer
15.	736-0506	Special Washer
16.	746-0902	Chute Control Cable
17.	746-0903	Chute Cable w/Clip
18.	784-5594	Cable Bracket
19.	784-5604	Chute Tilt Handle
20.	684-0102	Handle Panel Assembly w/ Tilt
21.	710-0459A	Hex Bolt 3/8-24 x 1.5"
22.	710-0599	TT Screw 1/4-20 x 0.5"
23.	711-0653	Clevis Pin
24.	712-0116	Jam Nut
25.	784-5682	Handle Suppt. Bracket 3/8 RH
26.	714-0104	Cotter Pin
27.	732-0145	Spring
28.	732-0193	Spring
29.	732-0746	Torsion Spring
30.	735-0199A	Rubber Bumper
31.	736-0105	Bell Washer
32.	784-5681	Handle Suppt. Bracket 3/8 LH
33.	736-0509	Special Washer
34.	747-0877	Cam Rod
35.	748-0362	Cam: Handle Lock
36.	748-0363	Pawl: Handle Lock
37.	784-5619A	Shift Handle
38.	784-5679	Handle Suppt. Bracket 5/8 LH
39.	714-0507	Hairpin Clip
40.	712-3010	Hex Nut 5/16-18
41.	736-0242	Bell Washer
42.	784-5647	Chute Crank Bracket
43.	710-0451	Carriage Bolt 5/16-18 x .750"
44.	741-0475	Plastic Bushing

MANUFACTURER'S LIMITED WARRANTY FOR:



The limited warranty set forth below is given by Troy-Bilt LLC with respect to new merchandise purchased and used in the United States, its possessions and territories.

Troy-Bilt LLC warrants this product against defects for a period of two (2) years commencing on the date of original purchase and will, at its option, repair or replace, free of charge, any part found to be defective in materials or workmanship. This limited warranty shall only apply if this product has been operated and maintained in accordance with the Operator's Manual furnished with the product, and has not been subject to misuse, abuse, commercial use, neglect, accident, improper maintenance, alteration, vandalism, theft, fire, water, or damage because of other peril or natural disaster. Damage resulting from the installation or use of any accessory or attachment not approved by Troy-Bilt LLC for use with the product(s) covered by this manual will void your warranty as to any resulting damage.

Normal wear parts or components thereof are subject to separate terms as follows: All normal wear parts or component failures will be covered on the product for a period of 90 days regardless of cause. After 90 days, but within the two year period, normal wear part failures will be covered ONLY IF caused by defects in materials or workmanship of OTHER component parts. Normal wear parts and components include, but are not limited to: batteries, belts, blades, blade adapters, grass bags, rider deck wheels, seats, snow thrower skid shoes, shave plates, auger spiral rubber, and tires.

HOW TO OBTAIN SERVICE: Warranty service is available, WITH PROOF OF PURCHASE, through your local authorized service dealer. To locate the dealer in your area, check your Yellow Pages, or contact Troy-Bilt LLC at P.O. Box 361131, Cleveland, Ohio 44136-0019, or call 1-866-840-6483 or 1-330-558-7220, or log on to our Web site at www.troybilt.com.

This limited warranty does not provide coverage in the following cases:

- a. The engine or component parts thereof. These items carry a separate manufacturer's warranty. Refer to applicable manufacturer's warranty for terms and conditions.
- b. Log splitter pumps, valves, and cylinders have a separate one year warranty.
- c. Routine maintenance items such as lubricants, filters, blade sharpening, tune-ups, brake adjustments, clutch adjustments, deck adjustments, and normal deterioration of the exterior finish due to use or exposure.
- d. Troy-Bilt LLC does not extend any warranty for products sold or exported outside of the United States, its possessions and territories, except those sold through Troy-Bilt LLC's authorized channels of export distribution.
- e. Parts that are not genuine Troy-Bilt parts are not covered by this warranty.
- f. Service completed by someone other than an authorized service dealer is not covered by this warranty.
- g. Transportation charges and service calls are not covered.

No implied warranty, including any implied warranty of merchantability of fitness for a particular purpose, applies after the applicable period of express written warranty above as to the parts as identified. No other express warranty, whether written or oral, except as mentioned above, given by any person or entity, including a dealer or retailer, with respect to any product, shall bind Troy-Bilt LLC. During the period of the warranty, the exclusive remedy is repair or replacement of the product as set forth above.

The provisions as set forth in this warranty provide the sole and exclusive remedy arising from the sale. Troy-Bilt LLC shall not be liable for incidental or consequential loss or damage including, without limitation, expenses incurred for substitute or replacement lawn care services or for rental expenses to temporarily replace a warranted product.

Some states do not allow the exclusion or limitation of incidental or consequential damages, or limitations on how long an implied warranty lasts, so the above exclusions or limitations may not apply to you.

In no event shall recovery of any kind be greater than the amount of the purchase price of the product sold. **Alteration of safety features of the product shall void this warranty.** You assume the risk and liability for loss, damage, or injury to you and your property and/or to others and their property arising out of the misuse or inability to use the product.

This limited warranty shall not extend to anyone other than the original purchaser or to the person for whom it was purchased as a gift.

HOW STATE LAW RELATES TO THIS WARRANTY: This limited warranty gives you specific legal rights, and you may also have other rights which vary from state to state.

Troy-Bilt LLC, P.O. BOX 361131 CLEVELAND, OHIO 44136-0019; Phone: 1-866-840-6483, 1-330-558-7220