

Operator's Manual



SCROLL SAW

Model No.
137.216200

1/9 HP (Max. Developed)
Pin-end or Plain-end Blade
400-1600 S.P.M.

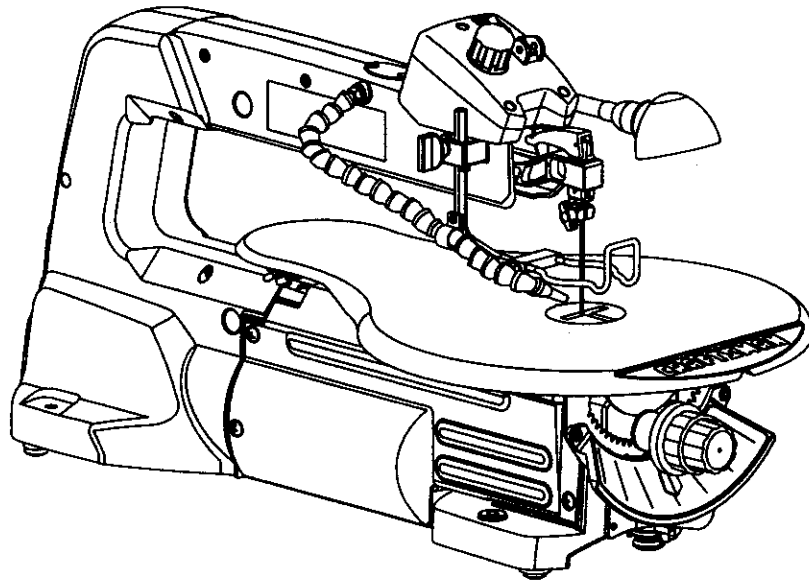

CAUTION:

Before using this Scroll Saw, read this manual and follow all its Safety Rules and Operating Instructions

- Safety Instructions
- Installation
- Operation
- Maintenance
- Parts List

Customer Help Line
1-800-843-1682

Sears, Roebuck and Co., Hoffman Estates, IL 60179 USA
Part No. 137216200001

TABLE OF CONTENTS

SECTION	PAGE
Product Specifications	2
Warning	2
Safety Instructions	3
Accessories and Attachments	6
Carton Contents	6
Know Your Scroll Saw	8
Glossary of Terms	9
Assembly and Adjustments	10
Basic saw Operation	14
Maintenance	17
Troubleshooting Guide	18
Parts	20

WARRANTY

FULL ONE YEAR WARRANTY

If this Scroll Saw fails due to a defect in material or workmanship within one year of date of purchase, Sears will at its option repair or replace it free of charge.

Return this Scroll Saw to a Sears Service Center for repair, or to place of purchase for replacement.

This warranty gives you specific legal rights, and you may also have other rights which may vary from state to state.

Sears, Roebuck and Co., Dept. 817 WA, Hoffman Estates, IL 60179

▲ WARNING

Some dust created by power sanding, sawing, grinding, drilling and other construction activities contains chemicals known to the state of California to cause cancer, birth defects or other reproductive harm. Some examples of these chemicals are:

- Lead from lead-based paints
- Crystalline silica from bricks, cement and other masonry products
- Arsenic and chromium from chemically treated lumber

Your risk from these exposures varies, depending on how often you do this type of work. To reduce your exposure to these chemicals, work in a well ventilated area and work with approved safety equipment such as dust masks that are specially designed to filter out microscopic particles.

PRODUCT SPECIFICATIONS

Motor

Power source 120 V, 60 Hz, 1.4Amp., Ac
 Speed 400 ~ 1600 spm
 Speed control Electronic

Blade

Type Pin-end or Plain-end
 Depth of Throat 20-1/4"
 Blade Stroke 3/4"
 Depth of 45°Cut 1-1/8" Left; 3/4" Right
 Depth of 90°Cut 2-1/4"

Table

Size 23-23/32" X 15-11/16"
 Tilt 45°Left; Right

SAWDUST BLOWER Yes

▲ WARNING

To avoid electrical hazards, fire hazards, or damage to the tool, use proper circuit protection. Use a separate electrical circuit for your tools.

Your scroll saw is wired at the factory for 120V operation. Connect to a 120V, 15 AMP branch circuit and use a 15 Amp time delay fuse or circuit breaker. To avoid shock or fire, replace power cord immediately if it is worn, cut or damaged in any way.

SAFETY

GENERAL SAFETY INSTRUCTIONS

BEFORE USING THE SCROLL SAW

Safety is a combination of common sense, staying alert and knowing how to use your scroll saw.

▲ WARNING

To avoid mistakes that could cause serious injury, do not plug the Scroll Saw in until you have read and understood the following.

- 1. READ** and become familiar with the entire Operator's Manual. **LEARN** the tool's application, limitations and possible hazards.
- 2. KEEP GUARDS IN PLACE** and in working order.
- 3. REMOVE ADJUSTING KEYS AND WRENCHES.** From the habit of checking to see that keys and adjusting wrenches are removed from the tool before turning ON.
- 4. KEEP WORK AREA CLEAN.** Cluttered areas and benches invite accidents.
- 5. DON'T USE IN DANGEROUS ENVIRONMENT.** Don't use power tools in damp and wet locations, or expose them to rain. Keep work area well lighted.
- 6. KEEP CHILDREN AWAY.** All visitors should be kept a safe distance from work area.
- 7. MAKE WORKSHOP CHILD PROOF** with padlocks, master switches, or by removing starter keys.
- 8. DON'T FORCE THE TOOL.** It will do the job better and safer at the rate for which it was designed.
- 9. USE THE RIGHT TOOL.** Do not force tool or attachment to do a job for which it was not designed.
- 10. USE PROPER EXTENSION CORD.** Make sure your extension cord is in good condition. When using an extension cord, be sure to use one heavy enough to carry the current your product will draw. An undersized cord will result in a drop in line voltage and in loss of power which will cause the tool to overheat. The table on page 5 shows the correct size to use depending on cord length and nameplate ampere rating. If in doubt, use the next heavier gauge. The smaller the gauge number, the heavier the cord.
- 11. WEAR PROPER APPAREL.** Do not wear loose clothing, gloves, neckties, rings, bracelets, or other jewelry which may get caught in moving parts. Non-slip footwear is recommended. Wear protective hair covering to contain long hair.
- 12. ALWAYS WEAR EYE PROTECTION.** Any scroll saw can throw foreign objects into the eyes and could cause permanent eye damage. **ALWAYS** wear Safety Goggles (not glasses) that comply with ANSI Safety standard Z87.1. Everyday eyeglasses have only impact-resistance lenses. They **ARE NOT** safety glasses. Safety Goggles are available at Sears. **NOTE:** Glasses or goggles not in compliance with ANSI Z87.1 could cause serious injury when they break.
- 13. WEAR A FACE MASK OR DUST MASK.** Sawing operation produces dust.
- 14. SECURE WORK.** Use clamps or a vise to hold work when practical. It's safer than using your hand and it frees both hands to operate tool.
- 15. DISCONNECT TOOLS** before servicing; when changing accessories such as blades, bits, cutters, and the like.
- 16. REDUCE THE RISK OF UNINTENTIONAL STARTING.** Make sure switch is in OFF position before plugging in.
- 17. USE RECOMMENDED ACCESSORIES.** Consult the Operator's Manual for recommended accessories. The use of improper accessories may cause risk of injury to persons.
- 18. NEVER STAND ON TOOL.** Serious injury could occur if the tool is tipped or if the cutting tool is unintentionally contacted.
- 19. CHECK FOR DAMAGED PARTS.** Before further use of the tool, a guard or other part that is damaged should be carefully checked to determine that it will operate properly and perform its intended function – check for alignment of moving parts, binding of moving parts, breakage of parts, mounting, and any other conditions that may affect its operation. A guard or other part that is damaged should be properly repaired or replaced.
- 20. NEVER LEAVE TOOL RUNNING UNATTENDED. TURN POWER "OFF".** Don't leave tool until it comes to a complete stop.
- 21. DON'T OVERREACH.** Keep proper footing and balance at all times.
- 22. MAINTAIN TOOLS WITH CARE.** Keep tools sharp and clean for best and safest performance. Follow instructions for lubricating and changing accessories.
- 23. DIRECTION OF FEED.** Feed work into a blade or cutter against the direction of rotation of the blade or cutter only.
- 24. DO NOT** operate the tool if you are under the influence of any drugs, alcohol or medication that could affect your ability to use the tool properly.

25. DUST GENERATED from certain materials can be hazardous to your health. Always operate the saw in well-ventilated area and provide for proper dust removal. Use dust collection systems whenever possible.

SPECIFIC SAFETY INSTRUCTIONS FOR SCROLL SAWS

1. **READ AND UNDERSTAND** all safety instructions and operating procedures throughout the manual.
2. **DO NOT** operate the scroll saw until it is completely assembled and installed according to the instructions.
3. **SHOULD** any part of scroll saw be missing, damaged, or fail in any way, or any electrical component fail to perform properly, shut off the switch and remove the plug from the power supply outlet. Replace missing, damaged, or failed parts before resuming operation.
4. **IF YOU ARE NOT** thoroughly familiar with the operation of the scroll saw, obtain advice from your supervisor, instructor, or other qualified person.
5. **SERIOUS INJURY** could occur if the tool tips over or you accidentally hit the cutting tool. Do not store anything above or near the tool.
6. **AVOID INJURY** from unexpected saw movement. Place the saw on a firm level surface where the saw does not rock, and bolt or clamp the saw to its support.
7. **YOUR SCROLL SAW MUST BE SECURELY FASTENED** to a stand or workbench. If there is any tendency for the stand or workbench to move during operation, the stand or workbench **MUST** be fastened to the floor.
8. **THIS SCROLL SAW** is intended for indoor use only.
9. **TENSION BLADE PROPERLY** before starting the saw. Recheck and adjust tension as needed.
10. **BLADE TEETH MUST POINT** downward toward the table.
11. **TABLE MUST BE CLEARED** of all debris before operating saw. Do not perform layout, set up or assemble work on the table when the saw is in operation.
12. **TO PREVENT INJURIES**, avoid awkward hand or finger positions, where a sudden slip could cause a hand to move into the blade when operating the saw.
13. **HOLD WORKPIECE FIRMLY** against the scroll saw table top.
14. **NEVER CUT MATERIAL** that is too small to be held safely.
15. **DO NOT USE** dull or bent blades.
16. **TURN THE SAW OFF AND UNPLUG THE CORD** if the blade binds in the saw kerf while being backed out of the workpiece, usually caused by sawdust clogging the kerf. If this happens, turn off the scroll saw and unplug the power cord. Wedge open the kerf and back the blade out of the workpiece.
17. **DO NOT** feed the material too fast while cutting. Only feed the workpiece at the rate the saw will cut.
18. **TURN THE POWER OFF**, remove the switch key and make sure the scroll saw comes to a complete stop before installing or removing an accessory, and before leaving the work area.
19. **DO NOT START** the saw with workpiece pressing against the blade. Slowly feed the workpiece into the moving blade.
20. **WHEN CUTTING** a large workpiece. **MAKE SURE** the material is supported at table height.
21. **EXERCISE CAUTION** when cutting workpieces that are round or irregularly shaped, workpieces can pinch the blade.
22. **ALWAYS** release blade tension before loosening the blade holder screw.
23. **MAKE CERTAIN** table tilting lock is tightened before starting the machine.
24. **NEVER REACH** under the scroll saw table when motor is running.
25. **CHECK FOR DAMAGED PARTS** before each use. Check for alignment of moving parts, binding of moving parts, breakage of parts, mounting or any other conditions that may affect operation. Parts that are damaged should be properly repaired or replaced before using the tool.
26. **THINK SAFETY.**

ELECTRICAL REQUIREMENTS

GROUNDING INSTRUCTIONS

IN THE EVENT OF A MALFUNCTION OR BREAKDOWN, grounding provides a path of least resistance for electric current and reduces the risk of electric shock. This tool is equipped with an electric cord that has an equipment grounding conductor and a grounding plug. The plug **MUST** be plugged into a matching receptacle that is properly installed and grounded in accordance with ALL local codes and ordinances.

DO NOT MODIFY THE PLUG PROVIDED. If it will not fit the receptacle, have the proper receptacle installed by a qualified electrician.

IMPROPER CONNECTION of the equipment grounding conductor can result in risk of electric shock. The conductor with green insulation (with or without yellow stripes) is the equipment grounding conductor. If repair or replacement of the electric cord or plug is necessary, **DO NOT** connect the equipment grounding conductor to a live terminal.

CHECK with a qualified electrician or service person if you do not completely understand the grounding instructions, or if you are not sure the tool is properly grounded.

USE ONLY 3-WIRE EXTENSION CORDS THAT HAVE 3-PRONG GROUNDING PLUGS AND 3-POLE RECEPTACLES THAT ACCEPT THE TOOL'S PLUG. REPAIR OR REPLACE DAMAGED OR WORN CORD IMMEDIATELY.

GUIDELINES FOR EXTENSION CORDS

USE PROPER EXTENSION CORD. Make sure your extension cord is in good condition. When using an extension cord, be sure to use one heavy enough to carry the current your product will draw. An undersized cord will cause a drop in line voltage, resulting in loss of power and cause overheating. The table below shows the correct size to use depending on cord length and nameplate ampere rating. If in doubt, use the next heavier gauge. The smaller the gauge number, the heavier the cord.

Be sure your extension cord is properly wired and in good condition. Always replace a damaged extension cord or have it repaired by a qualified person before using it. Protect your extension cords from sharp objects, excessive heat and damp or wet areas.

Use a separate electrical circuit for your tools. This circuit must not be less than # 12 wire and should be protected with a 15 Amp time delay fuse. Before connecting the motor to the power line, make sure the switch is in the OFF position and the electric current is rated the same as the current stamped on the motor nameplate, running at a lower voltage will damage the motor.

This tool is intended for use on a circuit that has a receptacle like the one illustrated in FIGURE A. FIGURE A shows a 3-prong electrical plug and receptacle that has a grounding conductor. If a proper grounded receptacle is not available, an adapter (FIGURE B) can be used to temporarily connect this plug to a 2-contact grounded receptacle. The temporary adapter should be used only until a properly grounded receptacle can be installed by a qualified technician. The adapter (FIGURE B) has a rigid lug extending from it that **MUST** be connected to a permanent earth ground, such as a properly grounded receptacle box. The Canadian Electrical Code prohibits the use of the adapters.

CAUTION: In all cases, make certain the receptacle is properly grounded. If you are not sure, have a qualified electrician check the receptacle.

⚠ WARNING

This tool is for indoor use only. Do not expose to rain or use in damp locations.

Fig. A

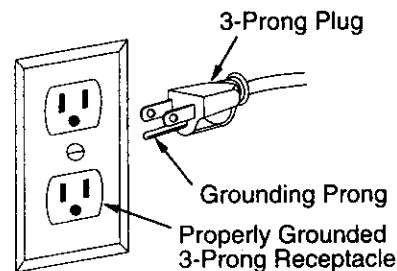
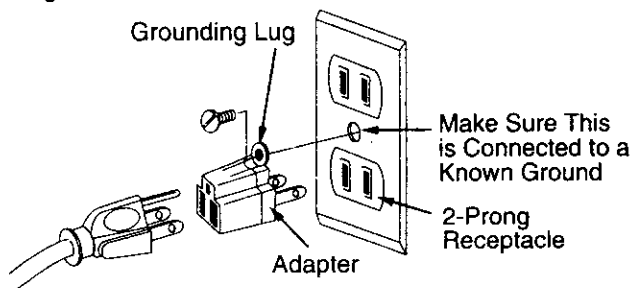

Fig. B



⚠ WARNING

This tool must be grounded while in use to protect the operator from electrical shock.

MINIMUM GAUGE FOR EXTENSION CORDS (AWG)					
(When using 120 volts only)					
Ampere	Rating	Total length of cord in feet			
More than	not more than	25'	50'	100'	150'
0	6	18	16	16	14
6	10	18	16	14	12
10	12	16	16	14	12
12	16	14	12	not recommended	

ACCESSORIES AND ATTACHMENTS

AVAILABLE ACCESSORIES

▲ WARNING

- To avoid injury, do not attempt to modify this tool or any accessories not recommended for use with this tool. Any such alteration or modification is misuse and could result in a hazardous condition leading to possible serious injury.
- Use only accessories available from Sears for this scroll saw. Follow instructions that accompany accessories. Use of improper accessories may cause hazards.

Visit your Sears Hardware Department or see the Sears Power and Handtool catalog for the following accessories:

ITEM

Pin-end saw blades
Plain-end saw blades
Scroll saw handbook
Scroll saw pattern kit

Sears may offer other accessories not listed in this manual.

See your nearest Sears store or Power and Hand Tool Catalog for other accessories.

Do not use any accessory unless you have completely read the instructions or Operator's Manual for that accessory.

CARTON CONTENTS

UNPACKING AND CHECKING CONTENTS

▲ WARNING

- To avoid injury, if any part is missing or damaged, do not plug the scroll saw in until the missing or damaged part is replaced, and assembly is complete.
- To avoid fire and toxic reaction, never use gasoline, naphtha, acetone, lacquer, thinner, or similar highly volatile solvents to clean the scroll saw.

Carefully unpack the scroll saw and all carton contents. Compare them to the following list and illustrations to make sure that they are all there.

To remove the scroll saw from the carton, lift the saw by the back of the upper frame.

ITEM	DESCRIPTION	QUANTITY
A.	Scroll saw	1
B.	Blades (2 Pin-end and 2 Plain-end)	4
C.	Hex wrench	1
D.	Knob	1
STAND:		
E.	Leg with leg flange	1
F.	Legs	3
G.	Top bracket	2
H.	Top bracket	2
I.	Bottom bracket (short)	2
J.	Bottom bracket (long)	2
K.	Foot pads	3
L.	Bolt	1
M.	Nut	1
N.	Mounting hex Bolt	4
O.	Flat washers	4
P.	Screws	20
Q.	Nuts	24

UNPACKING YOUR SCROLL SAW

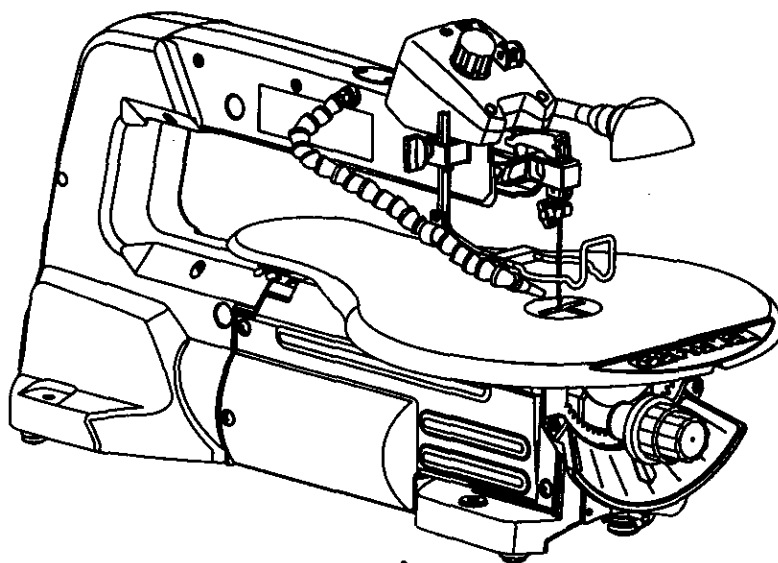

A



B

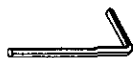

C



D

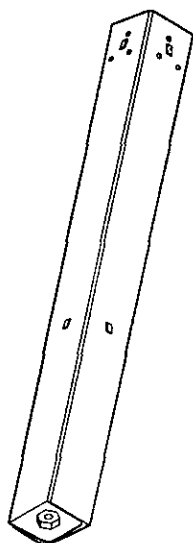

E

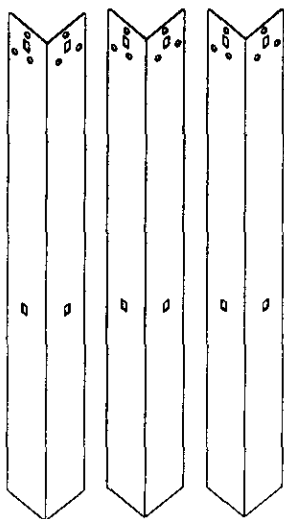

F

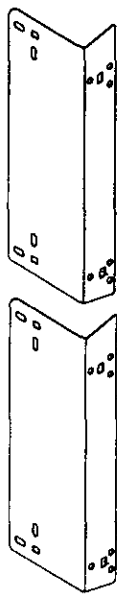

G

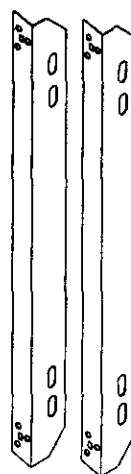

H

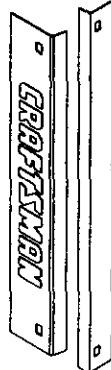

I



J



K



L



M



N



O



P



Q

KNOW YOUR SCROLL SAW

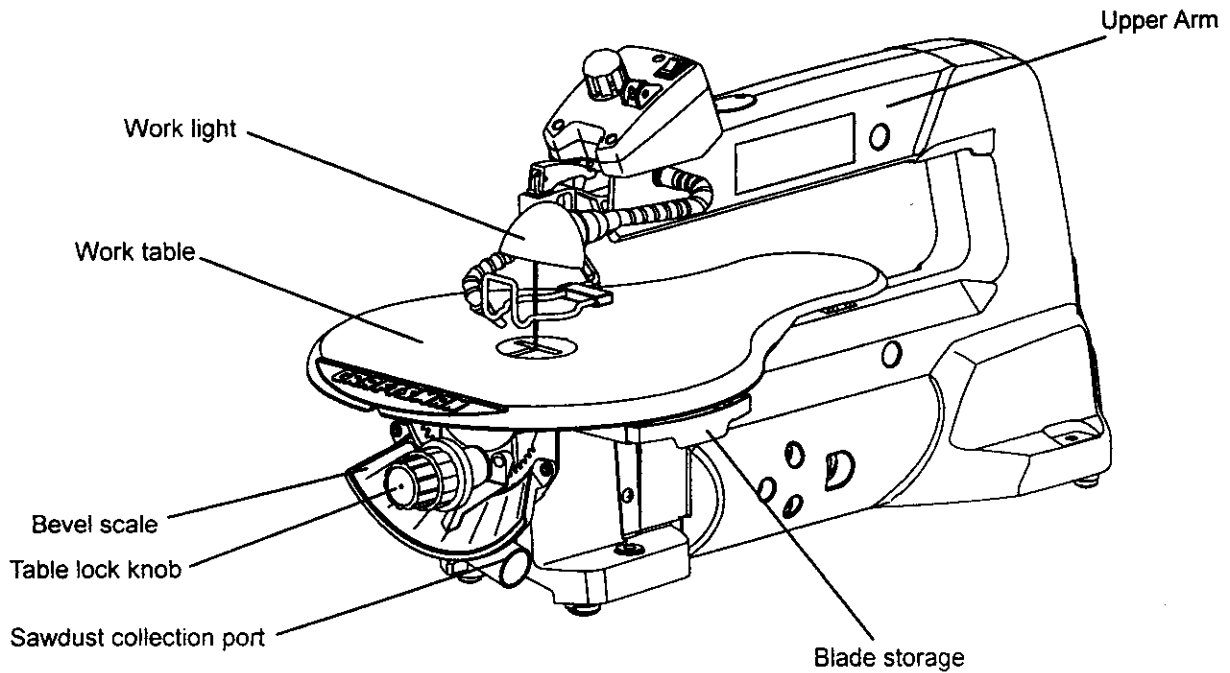
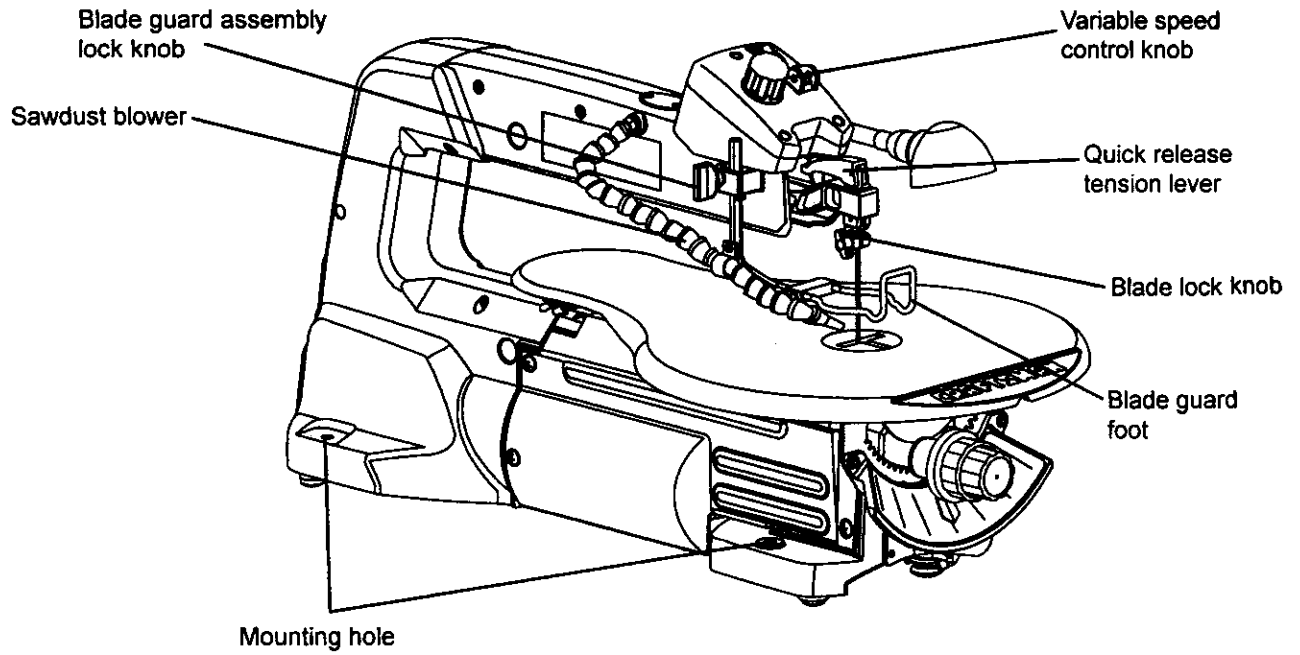

GLOSSARY OF TERMS

SCROLL SAW TERMS

BEVEL SCALE – Represents the degree of table angle, from 0° to 45°, when the table is tilted for bevel cutting.

BLADE GUARD ASSEMBLY – Guards the blade and keeps your workpiece from rising. Helps protect fingers from blade contact.

BLADE GUARD ASSEMBLY LOCK KNOB - Allows you to raise or lower the foot, and lock it at the desired height.

BLADE HOLDERS – Retain and position the blades.

BLADE STORAGE – Provides convenient easy access to extra blades or wrenches.

QUICK RELEASE TENSION LEVER – Quickly loosens and retightens the blade to its original tension. The tension lever quickly sets and resets the blade tension when performing interior cutting operations or changing blades.

SAWDUST BLOWER – Keeps sawdust from covering the line of sight for more accurate cuts. The best results occur when the blower tube is directed toward the blade and workpiece.

SAWDUST COLLECTION PORT – Allows vacuum attachments or hose to be used to remove the sawdust from under the table and base.

TABLE LOCK KNOB – Securely locks the table at the angle desired for bevel cutting.

VARIABLE SPEED ON/OFF CONTROL KNOB – Variable switch dial allows greater versatility when cutting a variety of materials. Pull the control knob OUT to turn the scroll saw ON. Adjust the speed to the desired setting, between 400 to 1600 strokes per minute (SPM), by turning the control knob clockwise or counter clockwise. Push the control knob IN to turn the scroll saw OFF.

WOODWORKING TERMS (FIG. A)

KERF – The slot cut by the blade.

LEADING EDGE – The front edge of the workpiece which is pushed into the blade.

SAW BLADE PATH – Area or line of sight of the workpiece moving in line toward the saw blade edge.

BLADE TOOTH SET – The total blade cut width, based on the distance from the outside point of one bent tooth to the outside point of the next bent tooth.

TRAILING EDGE – The edge of the workpiece that the sawblade will cut through last.

SURFACE – Top of workpiece being cut.

WORKPIECE – Material on which the cutting operation is being performed.

FEED – Rate of moving workpiece into the blade.

DEFLECTION – Slight movement of blade in the horizontal direction while the blade is moving in line during cutting operations. This may be caused by the blade following the grain or the path of least resistance.

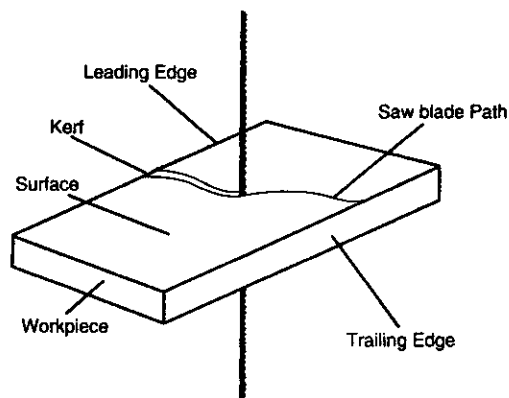

ASSEMBLY AND ADJUSTMENTS

ASSEMBLY INSTRUCTIONS

⚠ WARNING

This scroll saw comes completely assembled from the factory except for the leg set. To avoid injury, make sure all parts are assembled and adjusted properly before plugging into a power source outlet or turning this saw ON.

LEG SET ASSEMBLY (FIG. A)

1. Separate all parts and group by size style.
Note: Finger tighten bolts and nuts when joining parts.
2. Use bolts (Q) and nuts (R) to assemble the leg set parts.
3. Attach the leg (G,F) to the long top bracket (I). Attach the next leg to the opposite end of the top bracket.
4. Repeat this assembly for the opposite side of the leg set.
5. Attach the completed leg set assemblies to the short top brackets (H). Repeat on the opposite side.
6. Attach the two long bottom brackets (M) and two short bottom brackets (J), using the bolts (Q) and nuts (R).
7. Attach the pads (L) to the bottoms of the legs and insert bolt (M) into the leg flange hole and tighten using the nut (N) turn the stand upright on a level surface.
8. Tighten all nuts with an adjustable wrench.

Fig. A

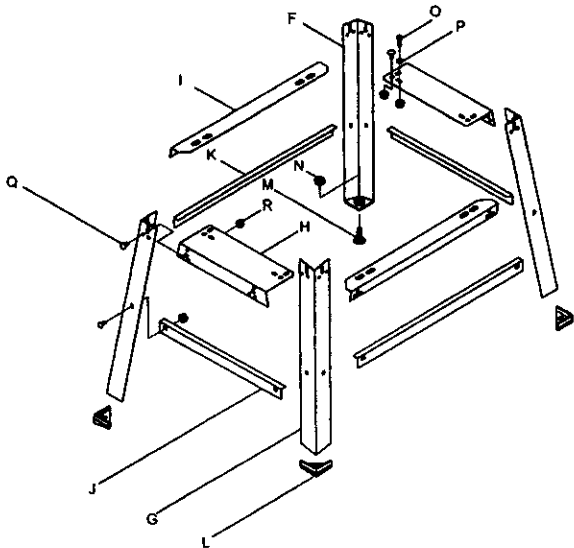

MOUNTING SAW TO STAND (FIG. B)

1. To mount your scroll saw to the stand, position the leg stand on a firm, level surface.
2. Matching the holes in the scroll saw base with the holes in the leg stand, place the scroll saw on the stand.
3. Secure the stand and saw using the hex bolts (O), flat washers (P), and nuts (R) provided. Tighten.

Fig. B

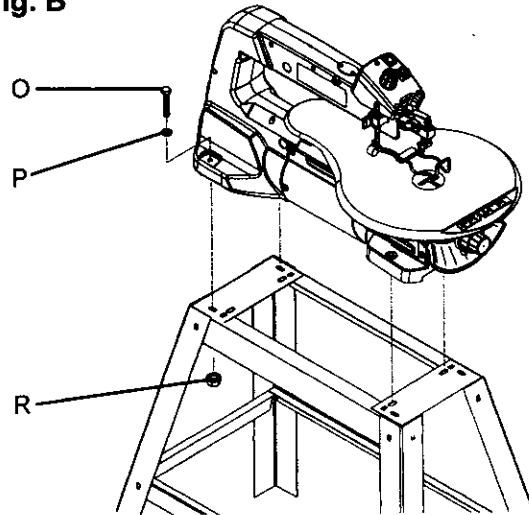

MOUNTING SAW TO WORKBENCH (FIG. C)

1. To mount your scroll saw in a permanent location such as a sturdy workbench, bolt the scroll saw base to a solid workbench top. The scroll saw base (1) has 4 mounting holes.
2. Place the scroll saw on the work surface (5), mark the holes on the work surface and drill 3/8" holes. Use bolts, washers, nuts to secure.
3. If the workbench moves or shakes during operation, it must be fastened to the floor.
4. Your scroll saw is designed to be used on horizontal surfaces only. Motor damage may result when mounted on a non-horizontal surface.

Fig. C

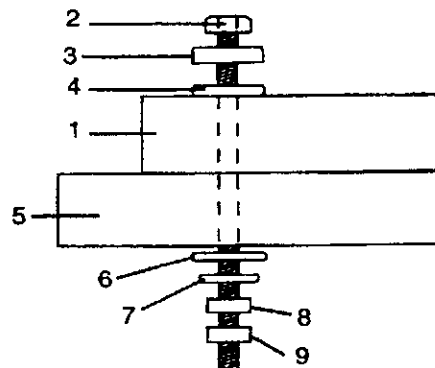

1. Scroll saw
2. Hex bolt
3. Rubber washer
4. Flat washer
5. Workbench
6. Flat washer
7. Lock washer
8. Hex nut
9. Jamb nut

BLADE STORAGE (FIG. D)

The blade storage (1) is located under the table. Pull out the blade storage (1) to open. The blade storage conveniently stores your hex wrenches, and both Pin and Plain end blades.

Fig. D

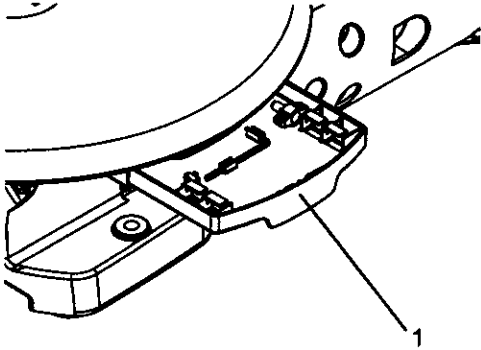

PLAIN-END BLADE REMOVAL (FIG. F, G, H, I)

1. To remove the blade (1), first loosen the blade tension by lifting the quick release tension lever (2) located on the saw's blade arm (3). (Fig. F)

Fig. F

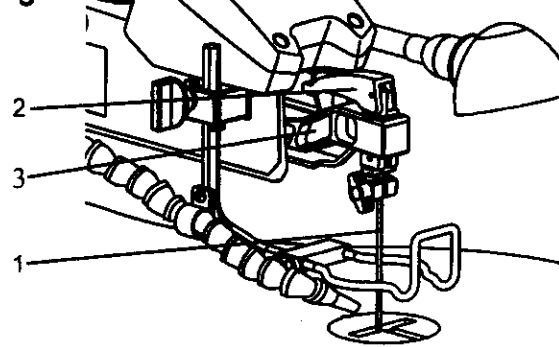

2. Loosen the upper blade holder (4) by turning the quick release knob (5) counterclockwise (Fig. G).

Note: The hex set screw (6) on the left side is used for fine adjustments and only needs to be adjusted if the blade is not perpendicular to the table.

Fig. G

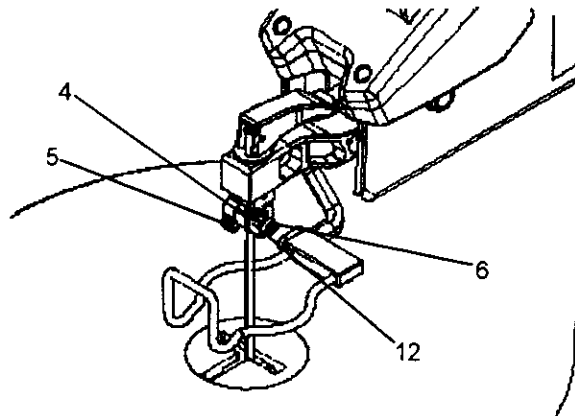

3. Tilt the table to 0° and tighten the bevel knob (7). Loosen the lower blade holder screw (9) under the table on the left side of the lower blade holder (8) by turning counterclockwise. (Fig. H)

Fig. H

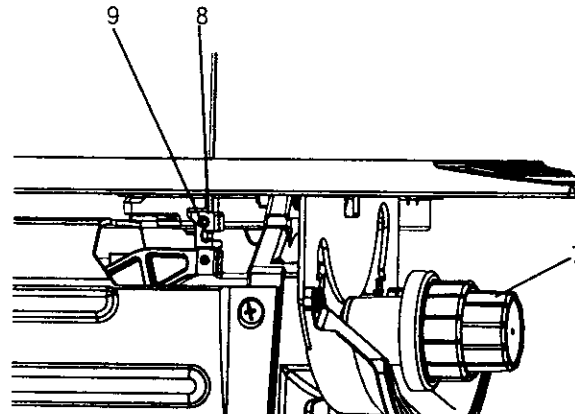

SAWDUST COLLECTION PORT (FIG. E)

To keep your saw cutting efficiently, you must keep the saw base free of sawdust buildup. For that purpose, this saw has a sawdust collection port (1) that will accept a vacuum hose (not provided).

If excessive sawdust buildup does occur inside the saw base, there is a metal plate (2) attached by four screws to the left side of the saw (as viewed from the front). Take out the screws and remove the metal plate. Clean out the sawdust manually or with a wet/dry vacuum. Reattach the metal plate.

Fig. E

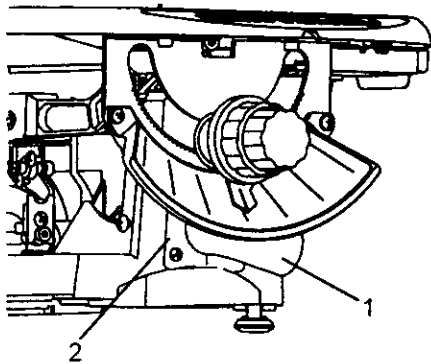

BLADE REMOVAL AND INSTALLATION

PLAIN-END BLADE REMOVAL AND INSTALLATION

This scroll saw accepts 5 inch plain-end or pin-end blades to cut a wide variety of materials.

Plain-end type blades are recommended whenever fine, accurate, and intricate work is being performed on 3/4" or thinner material. It will take slightly longer to install and tension the blade, but you will be able to use finer blades for cutting a thinner kerf.

⚠ WARNING

To avoid injury from accidental starting, always turn the switch OFF and remove power cord plug from power source before removing or replacing the blade.

4. Remove the blade (1), from the upper (4) and lower blade holders (8) by pulling forward and lifting the blade through the access hole (10) in the table (11). (Fig. I)

Fig. I

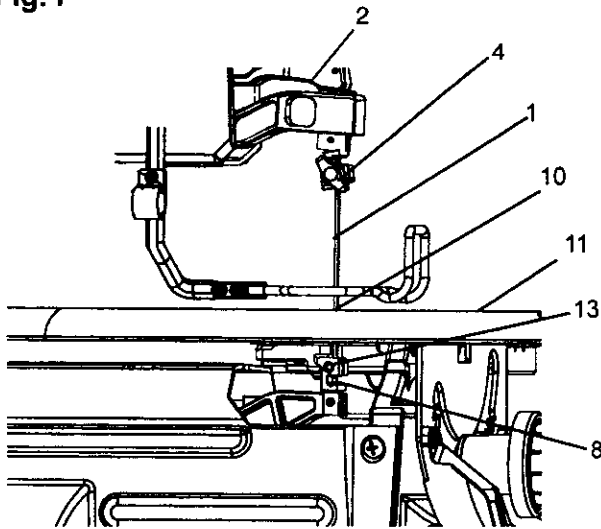

PLAIN-END BLADE INSTALLATION (FIG. F, G, H, I)

CAUTION: In order to avoid uncontrollable lifting of the workpiece, the teeth of the blade should ALWAYS point downward.

1. Install the blade (1) through the access hole (10) in the table (11) with teeth pointing down.
2. Insert the new blade (1) into the lower blade holder slot (13), then tighten the hex set screw (8). (Fig. I)
3. Tilt the table to the 0° bevel setting and lock the bevel knob (7). (Fig. H)
4. Insert the other end of the blade into the upper blade holder slot (12) and then tighten the quick release knob (2) (Fig. G).

Note: Apply slight downward pressure against the upper blade arm (7) when installing the blade into the upper blade holder. (Fig. K)

5. Tighten the tension on the blade (1) by turning the quick release lever (2) clockwise. Push the lock lever downward. Check the tension on the blade. If too loose, turn lever clockwise; do not make too tight or blade will easily break in use. (Fig. F)

Note: The quick release lever handle must always be down to make the tension adjustments. Release the quick release lever upward only during blade changing operations. If the blade is over-tightened, the lever is difficult to lower.

PIN-END BLADE REMOVAL AND INSTALLATION

▲ WARNING

To prevent personal injury, always turn the saw OFF and disconnect the plug from source before changing blades or making adjustments.

Pin-end type blades are thicker for stability and for faster assembly. These blades are required for faster cutting of material 3/4" thickness or greater. Also, use whenever less precision or thicker kerf cutting is acceptable.

Note: When installing pin-end blades, the set screws located on the upper and lower blade holders should not be over or under tightened. The slot must be slightly wider than the thickness of the blade. After the blade is installed, the blade tension mechanism will keep the pin-end in place.

PIN-END BLADE REMOVAL (FIG. J, K)

1. To remove the blade (1), loosen the tension by lifting up the quick release tension lever (2) (Fig. J)

Fig. J

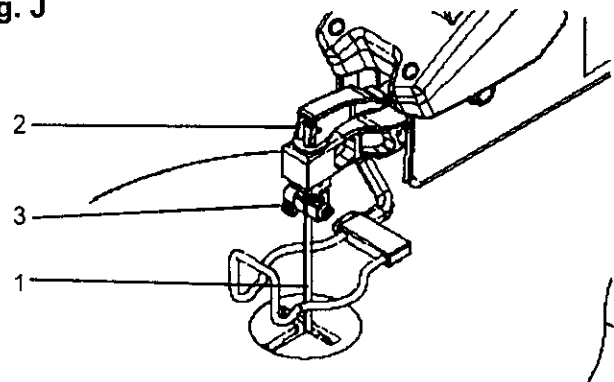

2. Remove the blade (1) from the upper (3) and lower (4) blade holder by pulling it forward to release, then lift the blade through the access hole (5). (Fig. K)

Fig. K

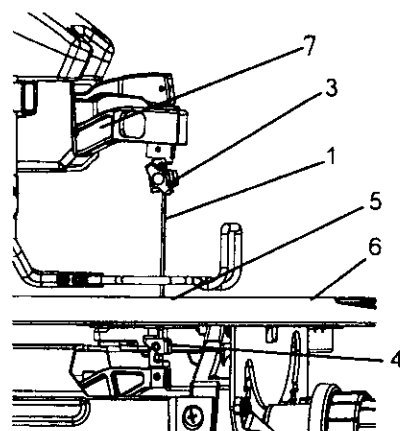

3. Tilt the table (6) to a 45° angle and lock the bevel lock knob to view lower blade holder (4). (Fig. K)

Note: Apply slight downward pressure on the upper blade arm (7) of the saw when removing the blade from the upper blade holder.

PIN-END BLADE INSTALLATION (FIG. L,M)

CAUTION: In order to avoid uncontrollable lifting of the workpiece, the teeth of the blade should always point downward.

1. Install the blade (1) by inserting one end of it through the access hole (6) or throat plate in the table. Hook the lower blade pin in the pin recess in the lower blade holder (5) and then the upper blade pin in the upper blade holder (4)(Fig. L).

Fig. L

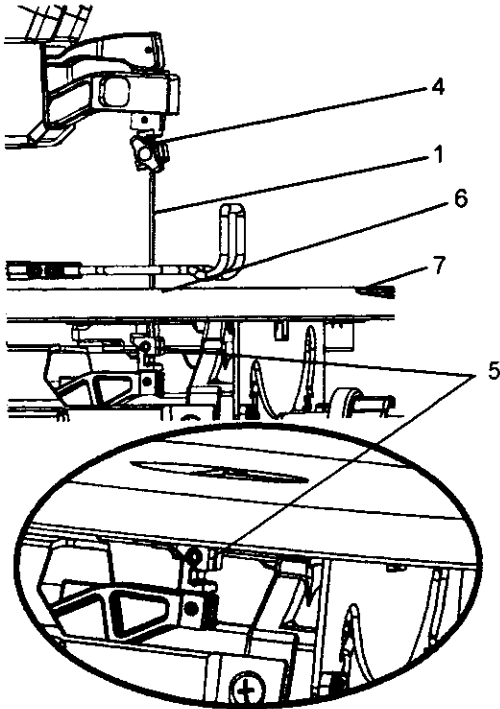

2. Check to see that the pins are properly located in the upper (4) and the lower (5) blade holders and move the table (7) to the 0° bevel position by unlocking the bevel lock knob.
3. To tension the blade (1), lower the quick release tension lever (2). Check the tension on the blade; if tension is too tight, turn the lever counterclockwise. If tension is too loose, turn the lever clockwise (Fig. M).

Note: If the blade is over tensioned, the lever will be difficult to lower and could result in damage to the blade holder or blade arm assembly.

Fig. M

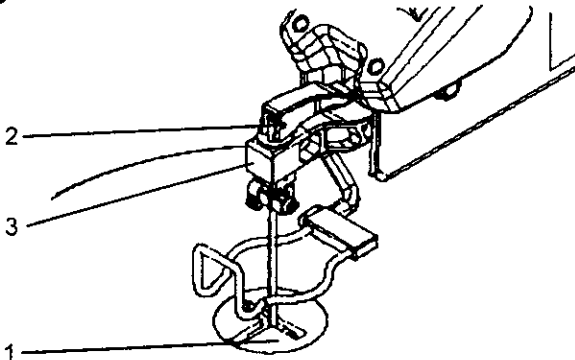

ADJUSTMENT

BLADE GUARD ASSEMBLY ADJUSTMENT (FIG. N)

When cutting at angles, the blade guard assembly (1) should be adjusted so it is parallel to the table and rests flat above the workpiece.

1. To adjust, loosen the screw (2), tilt the foot so it's parallel to table and tighten the screw.
2. Loosen the knob (3) to raise or lower the foot until it just rests on top of the workpiece. Tighten knob.

Fig. N

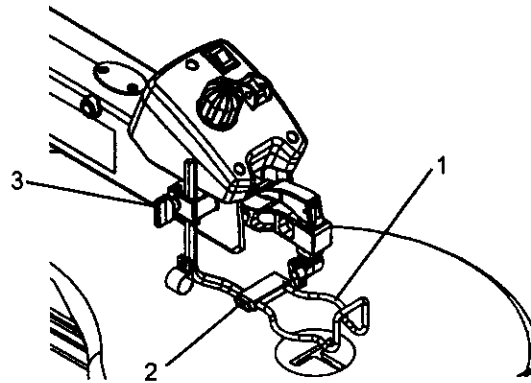

SAWDUST BLOWER (FIG. O)

The sawdust blower (1) should be positioned to point at the blade and workpiece to blow sawdust out of the line-of-sight when cutting. It is not designed to blow all of the sawdust off the table.

Fig. O

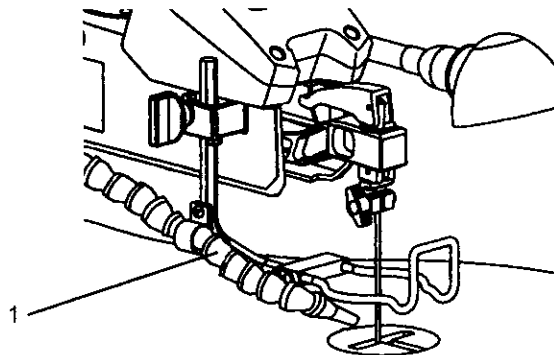

BLADE SELECTION

BLADE SELECTION (FIG. P)

To avoid injury from accidental starting, always turn the switch "OFF" and unplug the scroll saw before moving, replacing the blade, or making adjustments.

This scroll saw accepts 5" length blades with a wide variety of blade thickness and widths. The type of material and intricacies of cutting operations (size of radius or curve) will determine the number of teeth per inch. As a general rule, always select the narrowest blades for intricate curve cutting and the widest blades for straight and large curve cutting operations.

The following table represents suggestions for various materials. When purchasing blades, refer to the back of the package for the best use of blades and speeds on various materials. Use this table as a guide, but practice and your own personal preference will be the best selection method.

Fig. P

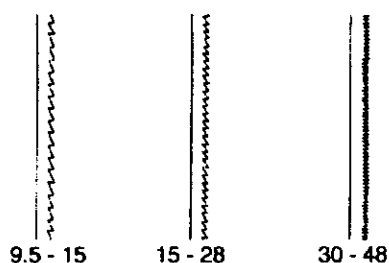

TEETH/ INCH TPI*	BLADE WIDTH INCH	BLADE THICKNESS INCH	BLADE/ SPM**	MATERIAL CUT
9.5-15	0.110	0.018	400-1200	Medium turns on 1/4" to 1-3/4" wood, soft metal and hardwoods
15-28	.055-.110	.010-.018	800-1800	Small turns on 1/8" to 1-1/2" wood, soft metal, hardwoods
30-48	.024-.041	.012-.019	Varies	Use very slow speeds on non-ferrous metals and hardwoods

* TPI: Teeth per inch

** SPM: Strokes per minute

Note: When using blades, sometimes speeds must change to compensate for smaller curves, radii, or smaller diameters. Thinner blades will have more possibilities for blade deflection when cutting angles which are not perpendicular to the table. Read BASIC SCROLL SAW OPERATION for more suggestions.

Note: The blade must be installed with the teeth pointing downward, as shown in FIG. P, to prevent the workpiece from being pulled upward by the saw blade action.

BASIC SAW OPERATION

VARIABLE SPEED CONTROL ON/OFF SWITCH

▲ WARNING

For your own safety, always push the control knob OFF when the scroll saw is not in use. Also, in the case of power failure push the knob OFF. Remove the plug from the power source outlet to avoid accidental starting.

The variable speed control allows greater versatility to cut a variety of materials such as wood, plastics, non-ferrous metals, etc. Depending on the hardness and thickness of material, the saw speed should be reduced to allow the blade teeth to remove cut material from the kerf.

REPLACING THE BULB

1. Use only a (10 watt maximum), candelabra base bulb. Turn the light switch OFF and unplug the saw.
2. Remove old bulb. Replace new bulb into socket.

VARIABLE SPEED SWITCH (FIG. Q)

Your saw is equipped with a variable speed dial (1). Adjust the blade stroke rate by rotating the dial. To increase speed, rotate dial clockwise. To reduce speed, rotate dial counterclockwise.

ON/OFF SWITCH (FIG. Q)

To turn power ON or OFF push the power switch (2).

OVERLOAD BREAKER (FIG. Q, R)

When the motor becomes too hot during operation, the overload breaker (3) will cause the motor to stop automatically to prevent damage to the motor. Push in on the toggle switch (2) to turn saw OFF and do not restart until the motor has had time to cool. Push in on the breaker switch (3) and switch the toggle switch (2) to ON to start the saw.

Fig. Q

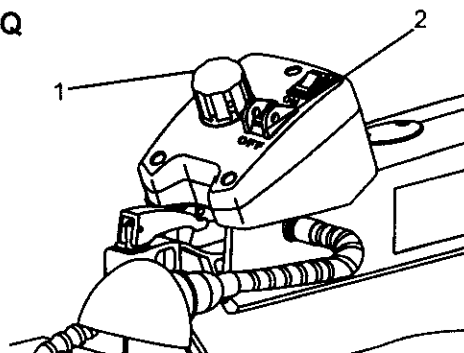
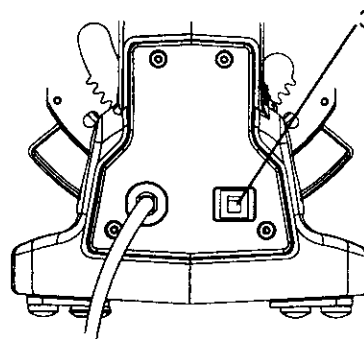

Fig. R



RECOMMENDATIONS FOR CUTTING

1. When feeding the workpiece into the blade do not force the leading edge of the workpiece into the blade because the blade will deflect, reducing the accuracy of cut and possibly breaking the blade. Allow the saw to cut material by guiding the workpiece into the blade as it cuts.
2. The blade teeth cut material **ONLY** on the down stroke.
3. You must guide the wood into the blade slowly because the teeth of the blade are very small and wood is removed only on the down stroke.
4. There is a learning curve for each person who wants to use this saw. During that period of time it is expected that some blades will break until you learn how to use the saw and receive the greatest benefit from the blades.
5. Best results are achieved when cutting wood less than one inch thick.
6. When cutting wood thicker than one inch the user must guide the wood very, very slowly into the blade and take extra care not to bend or twist the blade while cutting in order to maximize blade life.
7. Teeth on scroll saw blades wear out and must be replaced frequently for best cutting results. Scroll saw blades generally stay sharp for 1/2 to 2 hours of cutting.
8. To get accurate cuts be prepared to compensate for the blade's tendency to follow the wood grain as you are cutting.
9. This scroll saw is intended to cut wood or wood products. Precious and non-ferrous materials perform well on scroll saws that have very slow speed capability, and should be lubricated with machine oil or beeswax.
10. When choosing a blade to use with your scroll saw, use very fine, narrow blades to scroll cut thin wood of 1/4-inch or less thickness. Use wider blades for thicker materials but wider blades will reduce the ability to cut tight curves.
11. Blades wear faster when cutting abrasive materials like plywood or particle board. Angle cutting in hardwoods reduces blade tooth set faster due to blade deflection.

FREEHAND CUTTING (FIG. S)

⚠ WARNING

To avoid injury from an accidental start, make sure the switch is in the OFF position and the plug is not connected to the power source outlet.

1. Lay out desired design, or secure design to the workpiece (1).
2. Raise the blade guard assembly (2) by loosening the height adjustment knob (3).
3. Position the workpiece against the blade (3) and lower the blade guard assembly against the top surface of the workpiece.
4. Secure the blade guard assembly (2) by tightening the height adjustment knob (3).
5. Remove the workpiece from the blade prior to turning the scroll saw ON. Pull the speed control knob (4) out and set the desired speed by turning the control knob clockwise or counterclockwise.

CAUTION: In order to avoid uncontrollable lifting of the workpiece and to reduce blade breakage, do not pull the control knob ON while the workpiece is against the blade..

6. Slowly feed the workpiece into the blade, pressing the workpiece down against the table while cutting.

CAUTION : Do not force the leading edge of the workpiece into the blade. The blade will deflect, reducing accuracy of cut, and may break.

7. When the cut is complete, move the trailing edge of the workpiece beyond the blade guard foot. Push the control knob in to turn the scroll saw OFF.

Fig. S

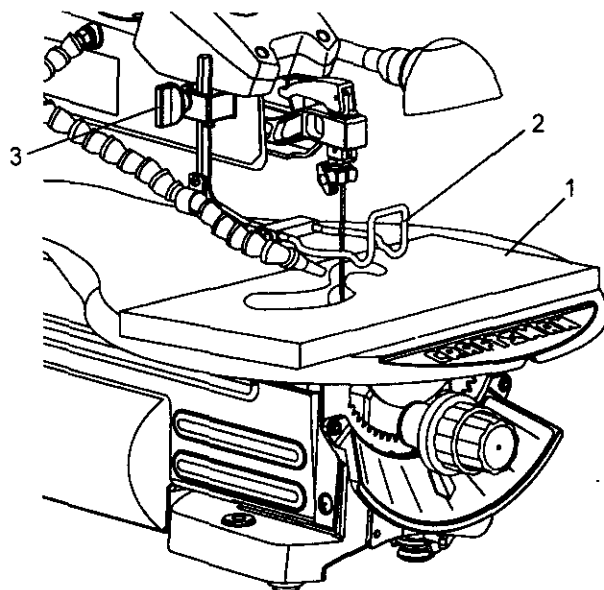

ANGLE CUTTING (FIG. T)

▲ WARNING

To avoid injury from an accidental starting, make sure the switch is in the OFF position and the plug is not connected to the power source outlet before moving, replacing the blade or making adjustments.

1. Lay out or secure design to workpiece (1).
2. Move the blade guard assembly (2) to the highest position by loosening the height adjustment knob (3) and retighten.
3. Tilt the table (4) to the desired angle by loosening the bevel lock handle (5) and moving the table to the proper angle, using the degree scale (6) and the pointer (7).
4. Tighten the bevel lock knob (5).
5. Loosen the blade guard screw (8), and tilt the blade guard to the same angle as the table (4). Retighten the blade guard screw.
6. Position the workpiece on the left and right side of the blade (9). Lower the blade guard assembly against the surface by loosening the height adjustment knob (3).
7. Follow items 4-8 under FREEHAND CUTTING OPERATION.

Fig. T

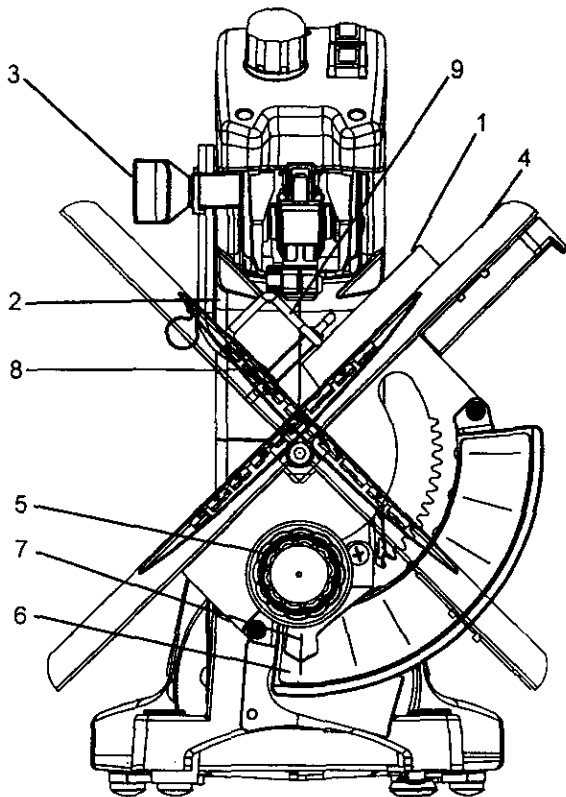

RIP OR STRAIGHT LINE CUTTING (FIG. U)

▲ WARNING

To avoid injury from an accidental starting, make sure the switch is in the OFF position and the plug is not connected to the power source outlet before moving, replacing the blade or making adjustments.

Tools Needed

QUANTITY	DESCRIPTION
2	Small C-clamps
1	Ruler or measuring tape
1	12" Straight scrap of wood (Thickness to match workpiece)

1. Raise the blade guard assembly (1) by loosening the height adjustment knob (2) on the right side of the upper blade arm. Position the straight edge (4) parallel to the blade at the desired ripping distance.
2. Clamp the straight edge (4) to the table (5).
3. Recheck your measurements, using the workpiece to be cut, and make sure the scrap wood is secure.
4. Position the workpiece against the blade and place the blade guard assembly (1) against the top surface of the workpiece.
5. Secure the blade guard assembly in place by tightening the height adjustment knob.
6. Remove the workpiece from the blade prior to turning the scroll saw ON. Pull the speed knob control out and set the desired speed by turning the control knob clockwise or counterclockwise.

CAUTION: In order to avoid uncontrollable lifting of the workpiece and reduce blade breakage, do not pull the control knob ON while the workpiece is against the blade.

7. Position the workpiece against the straight edge (4) prior to touching the leading edge of the workpiece against the blade (3).
 8. Slowly feed the workpiece into the blade, guiding the workpiece against the straight edge and pressing the workpiece down against the table while cutting.
- CAUTION:** Do not force the leading edge of the workpiece into the blade. The blade will deflect, reducing accuracy of cut, and may break.
9. When the cut is complete, move the trailing edge of the workpiece beyond the blade guard assembly.

Push the control knob in to turn the scroll saw OFF.
NOTE: When cutting a narrow workpiece use push sticks.

Fig. U

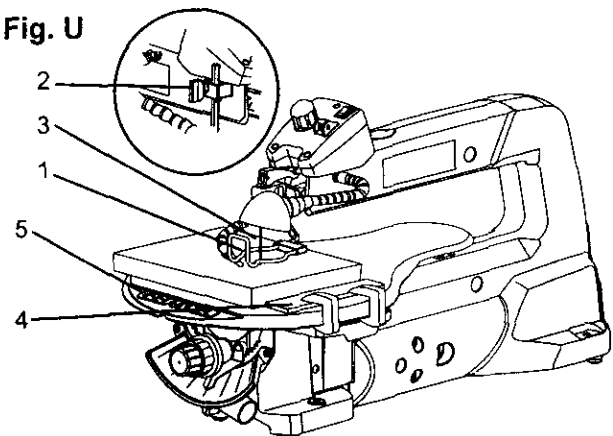

INTERIOR CUTTING (FIG. V)

1. Lay out the design on the workpiece (1). Drill a 1/4" hole in the workpiece.
2. Release the tension knob (2), and remove the blade (3). Refer to BLADE REMOVAL AND INSTALLATION.
3. Place the workpiece on the saw table with the workpiece hole over the access hole (4) in the table.
4. Install the blade (3) through the hole in the workpiece and access hole (4) and lower the quick release tension lever (2).
5. Follow the process, items 3-9, under FREEHAND CUTTING OPERATIONS.
6. When finished making the interior scroll cuts turn the scroll saw OFF, remove the blade from the blade holder, and remove the workpiece from the table.

Fig. V

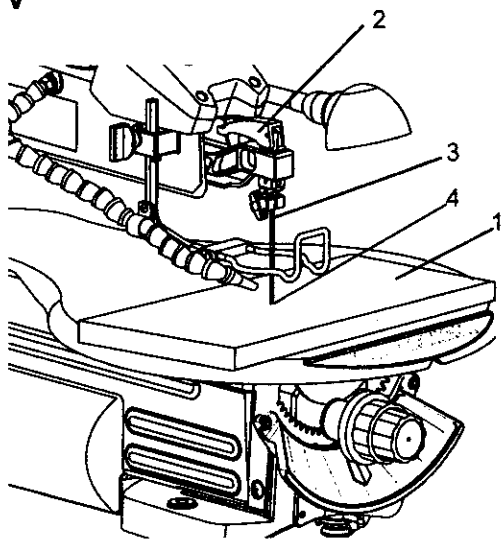

MAINTENANCE

▲ WARNING

For your own safety, turn the switch OFF and remove the plug from the power source before maintaining or lubricating your saw.

GENERAL

An occasional coat of paste wax on the work table will allow the wood being cut to glide smoothly across the work surface.

MOTOR

1. If the power cord is worn, cut, or damaged in any way, have it replaced immediately.
2. Do not attempt to oil the motor bearings or service the motor internal parts.

UPPER ARM BEARINGS (FIG. W)

Lubricate the upper arm bearings after every 50 hours of use.

1. Carefully lay the saw on its side.
2. Loosen the bushing with an 8mm hex key.
3. Squirt a generous amount of SAE 20 (lightweight) oil (1) around the shaft end and bearing (2).
4. Let the oil penetrate the bearing assembly overnight.
5. Replace and tighten. Turn the scroll saw over and repeat on the other side.

Fig. W

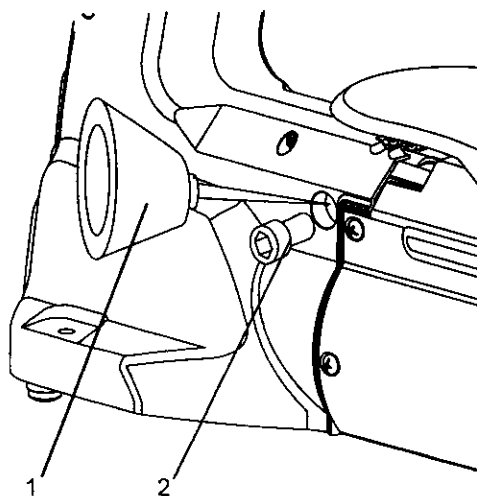

TROUBLESHOOTING

TROUBLESHOOTING GUIDE

▲ WARNING

To avoid injury from accidental starting, always turn switch OFF and unplug the scroll saw before moving, replacing the blade or making adjustments.

Contact your Sears Service Center if for any reason the motor will not run.

PROBLEM	CAUSE	REMEDY
Breaking blades	<ol style="list-style-type: none"> 1. Wrong tension. 2. Overworking blades. 3. Wrong blade application. 4. Twisting blade in wood. 	<ol style="list-style-type: none"> 1. Adjust blade tension. 2. Reduce feed rate. 3. Use narrow blade. 4. Avoid side pressure on blade.
Motor will not run.	<ol style="list-style-type: none"> 1. Defective cord or plug. 2. Defective motor. 3. Blown overload breaker. 	<ol style="list-style-type: none"> 1. Replace defective parts before using saw again. 2. Call Sears Service Center. Any attempt to repair this motor may create a HAZARD unless repair is done by a qualified technician. 3. Push the motor switch to the OFF position. Let the motor cool.
Excessive vibration. NOTE: There will always be some vibration present when the saw is running because of motor operation.	<ol style="list-style-type: none"> 1. Improper mounting of saw. 2. Unsuitable mounting surface. 3. Loose table or table resting against motor. 4. Loose motor mounting. 	<ol style="list-style-type: none"> 1. See mounting instructions in this manual for proper mounting technique. 2. The heavier your workbench is the less vibration will occur. A plywood workbench will not be as good work surface as the same size solid lumber. Use common sense in choosing a mounting surface. 3. Tighten the table lock knob. 4. Tighten motor mounting screw.
Blade not in line with blade arm motion.	<ol style="list-style-type: none"> 1. Blade holders not aligned. 	<ol style="list-style-type: none"> 1. Loosen cap screws holding blade holder to blade arms. Adjust position of blade holders. Retighten cap screw.

NOTE

PARTS LIST

20" SCROLL SAW

MODEL NO. 137.216200

▲ WARNING

When servicing use only CRAFTSMAN replacement parts. Use of any other parts may create a HAZARD or cause product damage.

Any attempt to repair or replace electrical parts on this scroll saw may create a HAZARD unless repair is done by a qualified service technician. Repair service is available at your nearest Sears Service Center.

ORDER ONLY BY MODEL NUMBER AND PART NUMBER

Key Part No.	Description	Size	Qty	Key Part No.	Description	Size	Qty
1	11A00101	PLUNGER HANDLE	1	61	16721602	BELLOWS	1
2	2501MBDN31	FLAT WASHER	1	62	11A12901	PLUG HOUSING	1
3	14403301	SPRING	1	63	2636BBDA07	CR. RE. COUNT HD. SCREW	M4X0.7-8 2
4	11A00401	TENSION HANDLE	1	64	2504MZC004	EXTERNAL TOOTH LOCK WASHER	1
5	11A00601	TILTING SCALE	1	65	2653MZDE11	CR. RE. TRUSS HD. TAPPING SCREW	M4X16-12 1
6	11A00701	TRUNNION BRACKET	1	66	18515401	RETAINING RING	1
7	2668BBDA08	CR. RE. PAN HD. SCREW	1	67	2620BBDC05	CR. RE. PAN HD. SCREW & WASHER	M6X1.0-25 1
8	2617BBLB19	HEX. SOC. HD. CAP BOLT	3	68	19A10701	PLUNGER HOUSING	1
9	2637BBDA70	CR. RE. TRUSS HD. SCREW	2	69	2617BBLC20	HEX. SOCKET HD. CAP SCREWS	M6X1.0-25 2
10	11A01101	NEEDLE POINTER	1	70	2707FBN107	U-TYPE NUT	4
11	11A01201	BRACKET TILT	1	71	11A13801	TRADE-MARK LABEL	2
12	2983AL5010	STEEL BALL	1	72	16702001A2	BEARING SEAT ASSY	1
13	16203001	COMPRESSION SPRING	1	73	20105PBA05	SPHERICAL BEARING	1
14	2668BBDA25	CR. RE. PAN HD. SCREW	1	74	11A15802	BUSH	2
15	11A01601	DUST COLLECTOR JOINT	2	75	14701101	WASHER	1
16		N/A		76	11A16002A1	ECCENTRIC ASSY	1
17	2603BBLA66	HEX. SOC. SET SCREW	1	77	18105002	BLADE	1
18	2602BBLA56	HEX. SOC. HD. CAP BOLT	1	78	15802104	BLADE	1
19		N/A		79	17104403A1	HOLDER BLADE ASSY	1
20	11A02201	BASE	1	80	11A16801A1	BOTTOM ARM ROCKER ASSY	1
21	2705FBD108	NUT CHUCK	1	81	2501MBDN06	FLAT WASHER	φ 6X13-1 2
22	11A02401	TABLE	1	82	2705FBD105	NUT CHUCK	M5X0.8 T=5 2
23	11A02501	INSERT	1	83	15802301	BEARING SEAT	4
24	2668BBDA24	CR. RE. PAN HD. SCREW	1	84	2602BBLA08	HEX. SOC. HD. CAP BOLT	M4X0.7-10 2
25	11A02701	RETAINING CLIP	2	85	14706601	SET PLATE	1
26	11A02801	BLADE BOX	1	86	2617BBLD13	HEX. SOCKET HD. CAP SCREWS	M5X0.8-40 1
27	2138MBL703	WRENCH HEX.	1	87	11A17901A1	LINGAGE BAR ASSY	1
28	2617BBLB58	HEX. SOCKET HD. CAP SCREWS	1	88	11A18001	EXTENSION SPRING	3
29		N/A		89	2677BBDA03	CR. RE. PAN HD. ROUND NECK SCRE	M4X0.7-7.5 1
30	2502ABC408	SPRING WASHER	1	90	11A18801A1	TENSION HANDLE ASSY	1
31	11A03401	CAUTION LABEL	1	91	18105001	BLADE	PLAIN 12.5 1
32	2501MWTN83	FLAT WASHER	1	92	17102701	BLADE	PIN 10T 2
33	11A03601	TRADE-MARK LABEL	1	93	15802103	BLADE	PIN 18T 1
34	2637BBDA39	CR. RE. TRUSS HD. SCREW	1	94	8586128827	MOTOR	1
35	11A10101	PLATE COVER	1	95	2637BBDA39	CR.-RE. TRUSS HD. SCREW	M6X1.0-12 1
36	11A10201	LABEL	1	96	2617BBLC21	HEX. SOCKET HD. CAP SCREWS	M6X1.0-16 1
37	16730102A1	AIR DUCT ASSY	1	97	11A25401	SWITCH BOX	2
38	16730001	PVC HOSE	1	98	2660MBCE14	CR. RE. PAN HD. TAPPING SCREW	M4X16-16 3
39	11A10501	CLAMP PLATE	1	99	11A25601	SWITCH BOX COVER	1
40	2603BBLA36	HEX. SOC. SET SCREW	2	100	2660PBCK15	CR. RE. PAN HD. TAPPING SCREW	M4X18-20 4
41	11A10701	PLUNGER HOUSING	1	101	2852U55722	ROCKER SWITCH	1
42	11A10901	SUPPORT ROD	1	102	11A25901	INDICATED BUTTON	3
43	16700805	CLAMP HANDLE	1	103	2701FBD107	HEX. NUT	M8X1.25 T= 2
44	11A11101	CLAMPER	1	104	2501NBDN59	FLAT WASHER	5/32X13/32- 1
45	11A11202	HOUSING	1	105	2680MBCK16	CR. RE. PAN HD. TAPPING SCREW	M5X0.8-10 1
46	18402702	DUST SHIELD	4	106	11A26302	HOUSING RIGHT	4
47	2660PBCK40	CR. RE. PAN HD. TAPPING SCREW	5	107	19A10101	CLAMP-CORD	4
48	11A11501	CONNECTOR BOX	1	108	11A26501A1	LAMP ASSY	1
49	11A11601A1	CONTROLLER ASSY	1	109	11A27001	STICKER	4
50	2660MBCE01	CR. RE. PAN HD. TAPPING SCREW	2	110	83990121	CLAMP-CORD	1
51	11A11801	CONNECTOR BOX COVER	1	111	2660MBCE14	CR. RE. PAN HD. TAPPING SCREW	1
52	2660PBCK23	CR. RE. PAN HD. TAPPING SCREW	4	112	11A27301	WARNING LABEL	1
53	2853D55714	CIRCUIT BREAKER SWITCH	1				
54	2801UBHA07	STRAIN RELIEF	1				
55	280655581Y	LEAD WIRE ASSY	1				
56	2807BB08HB	POWER CABLE	1				
57	19A10901	SHAFT-PIVOT	1				
58	2501MBDN21	FLAT WASHER	1				
59	2506MBN608	WAVE WASHER	1				
60	2705FBD106	NUT CHUCK	1				

21

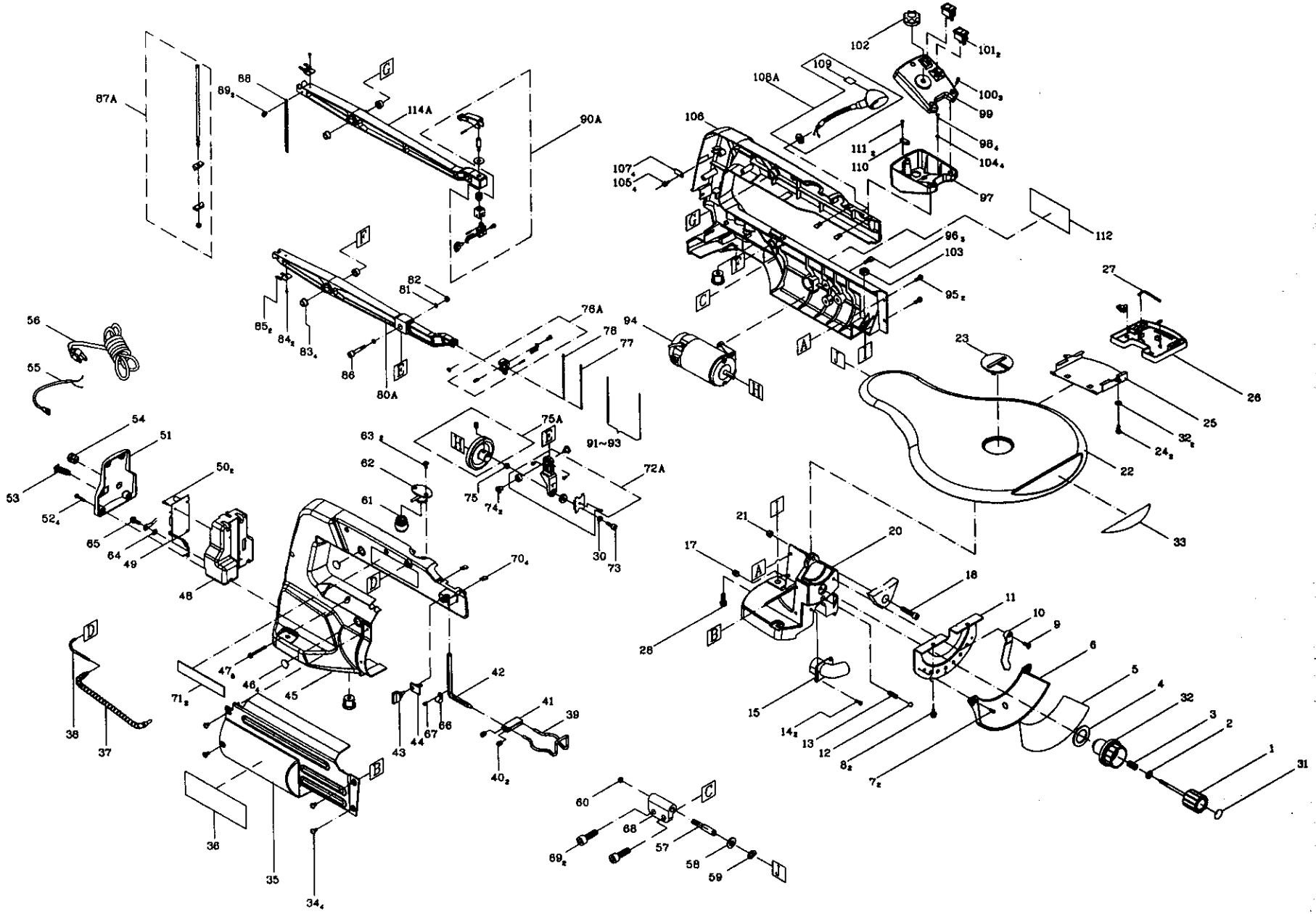

STAND PARTS LIST

ORDER ONLY BY MODEL NUMBER AND PART NUMBER

Key	Part No.	Description	Size	Qty
1	17010103	SPACER		3
2	17050111	SUPPORT BRACKET	L=748.3	3
3	17050511	BOTTOM SUPPORT BRACKET	L=428	1
4	2672BBDA54	CAP HD. SQ.NECK BOLT	M8x1.25-16	20
5	17050313	UPPER SUPPORT BRACKET	L=243	2
6	2708FBD112	SERRATED TOOTHED HEXAGON FLANG NUT	M8x1.25 T=7.5	24
7	17050412	BOTTOM SUPPORT BRACKET	L=810	2
8	17050215	UPPER SUPPORT	L=630	2
9	17050112	SUPPORT BRACKET	L=748.3	1
10	2701QBD509	HEX. NUT	3/8"X16UNC T=8	1
11	1A213201	SPACER		1
12	2601BBDA66	HEX. HD. BOLT	M8x1.25-70	4
13	2501MBDN21	FLAT WASHER	φ 8x16-1.4	4
14	17050510	BOTTOM SUPPORT BRACKET	L=428	1

20" SCROLL SAW

MODEL NO. 137.216200

STAND

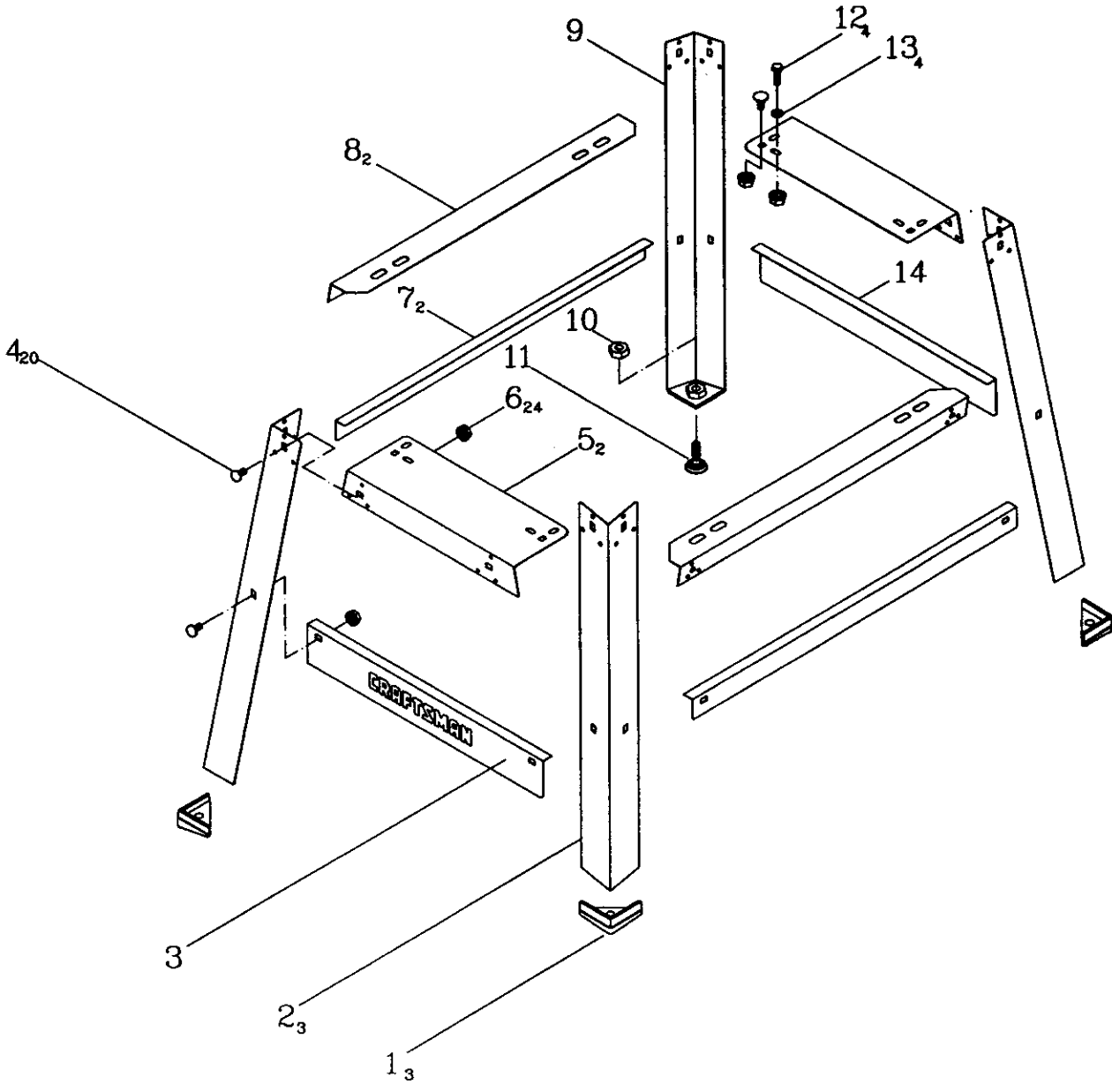

Get it fixed, at your home or ours!

For repair of major brand appliances in your own home...
no matter who made it, no matter who sold it!

1-800-4-MY-HOMESM Anytime, day or night
(1-800-469-4663)

www.sears.com

To bring in products such as vacuums, lawn equipment and electronics
for repair, call for the location of your nearest **Sears Parts & Repair Center.**

1-800-488-1222 Anytime, day or night

www.sears.com

For the replacement parts, accessories and owner's manuals
that you need to do-it-yourself, call **Sears PartsDirectSM!**

1-800-366-PART 6 a.m. – 11 p.m. CST,
(1-800-366-7278) 7 days a week

www.sears.com/partsdirect

To purchase or inquire about a Sears Service Agreement:

1-800-827-6655

7 a.m. – 5 p.m. CST, Mon. – Sat.

Para pedir servicio de reparación a domicilio,
y para ordenar piezas con entrega a domicilio:

1-888-SU-HOGARSM
(1-888-784-6427)

Au Canada pour service en français:

1-877-LE-FOYERSM
(1-877-533-6937)

