

WEIDER[®] PRO 202

Model No. 831.150260

Serial No. _____

Write the serial number in the space above for reference.

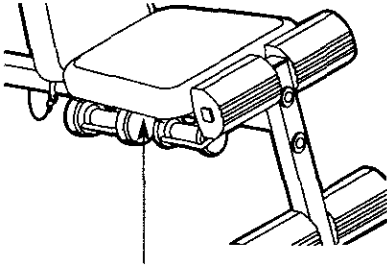

Serial Number Decal (under seat)

- Assembly
- Adjustments
- Part List and Drawing

▲ CAUTION

Read all precautions and instructions in this manual before using this equipment. Save this manual for future reference.

WEIGHT BENCH EXERCISER User's Manual

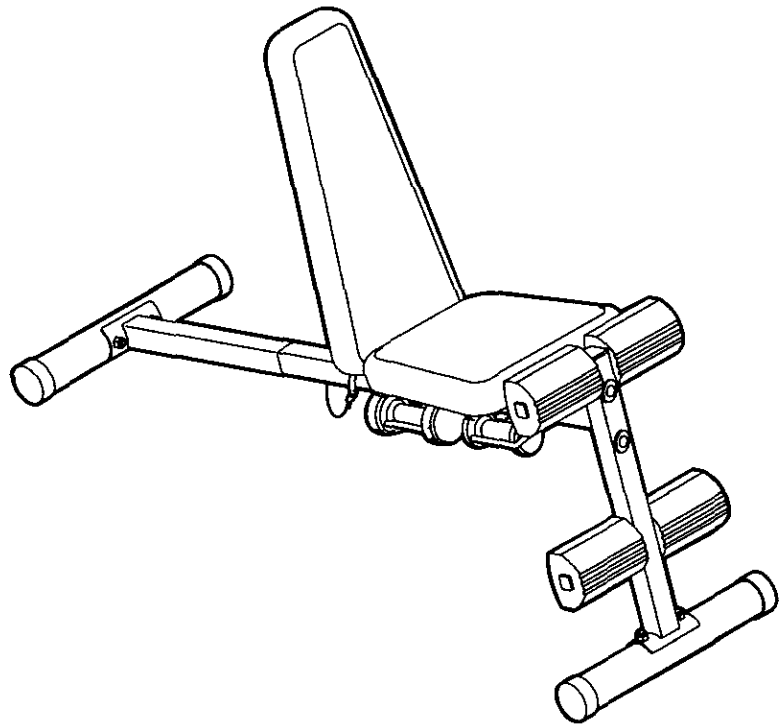

Patent Pending

Sears, Roebuck and Co., Hoffman Estates, IL 60179

TABLE OF CONTENTS

WARNING DECAL PLACEMENT	2
IMPORTANT PRECAUTIONS	3
BEFORE YOU BEGIN	4
PART IDENTIFICATION CHART	5
ASSEMBLY	6
ADJUSTMENTS	8
EXERCISE GUIDELINES	9
PART LIST/EXPLODED DRAWING	11
ORDERING REPLACEMENT PARTS	Back Cover
FULL 90 DAY WARRANTY	Back Cover

WARNING DECAL PLACEMENT

The decal shown here has been placed on the weight bench. If the decal is missing or illegible, please call toll-free 1-800-999-3756, Monday through Friday, 6 a.m. until 6 p.m. Mountain Time, to order a free replacement decal. Apply the decal in the location shown.

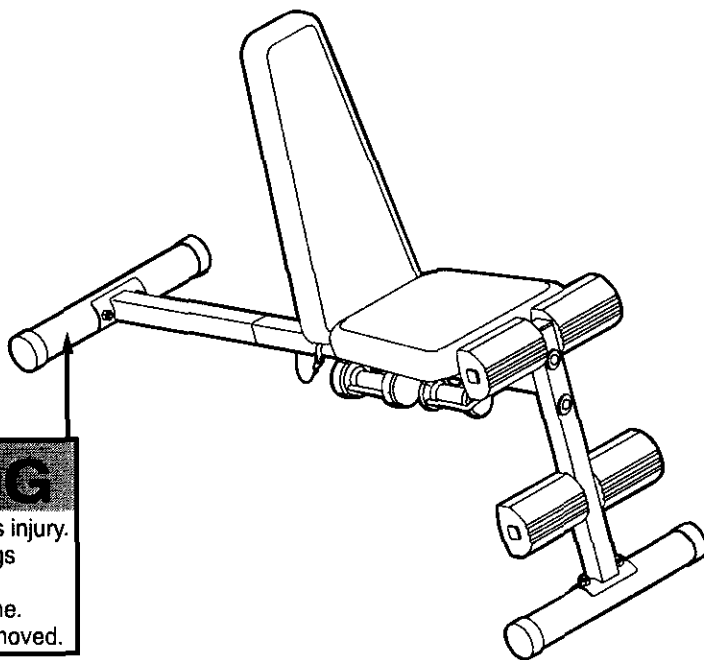

! WARNING

- Misuse of this product may result in serious injury.
- Read user's manual and follow all warnings and operating instructions prior to use.
- Do not allow children on or around machine.
- Replace label if damaged, illegible, or removed.

IMPORTANT PRECAUTIONS

⚠ WARNING: To reduce the risk of serious injury, read the following important precautions before using the weight bench.

1. Read all instructions in this manual before using the weight bench. Use the weight bench only as described in this manual.
2. It is the responsibility of the owner to ensure that all users of the weight bench are adequately informed of all precautions.
3. The weight bench is intended for home use only. Do not use the weight bench in any commercial, rental, or institutional setting.
4. Use the weight bench only on a level surface. Cover the floor beneath the weight bench to protect the floor.
5. Make sure all parts are properly tightened each time the weight bench is used. Replace any worn parts immediately.
6. Keep hands and feet away from moving parts.
7. Keep children under 12 and pets away from the weight bench at all times.
8. Always wear athletic shoes for foot protection while exercising.
9. The weight bench is designed to support a maximum of 410 pounds, including a maximum user weight of 300 pounds. Do not use more than 110 pounds of weight with the weight bench.
10. Always make sure that the locking pin is fully inserted into the pivot bracket and the frame before exercising.
11. If you feel pain or dizziness at any time while exercising, stop immediately and begin cooling down.

⚠ WARNING: Before beginning this or any exercise program, consult your physician. This is especially important for persons over the age of 35 or persons with pre-existing health problems. Read all instructions before using. Sears assumes no responsibility for personal injury or property damage sustained by or through the use of this product.

BEFORE YOU BEGIN

Thank you for selecting the versatile WEIDER® PRO 202 weight bench. The weight bench is designed to help develop the major muscle groups of the upper body. Whether your goal is to tone your body, build dramatic muscle size and strength, or improve your cardiovascular system, the weight bench will help you to achieve the specific results you want.

For your benefit, read this manual carefully before using the weight bench. If you have questions after

reading this manual, call 1-800-4-MY-HOME® (1-800-469-4663). To help us assist you, please note the product model number and serial number before calling. The model number is 831.150260. The serial number can be found on a decal attached to the weight bench (see the front cover of this manual).

Before reading further, please review the drawing below and familiarize yourself with the parts that are labeled.

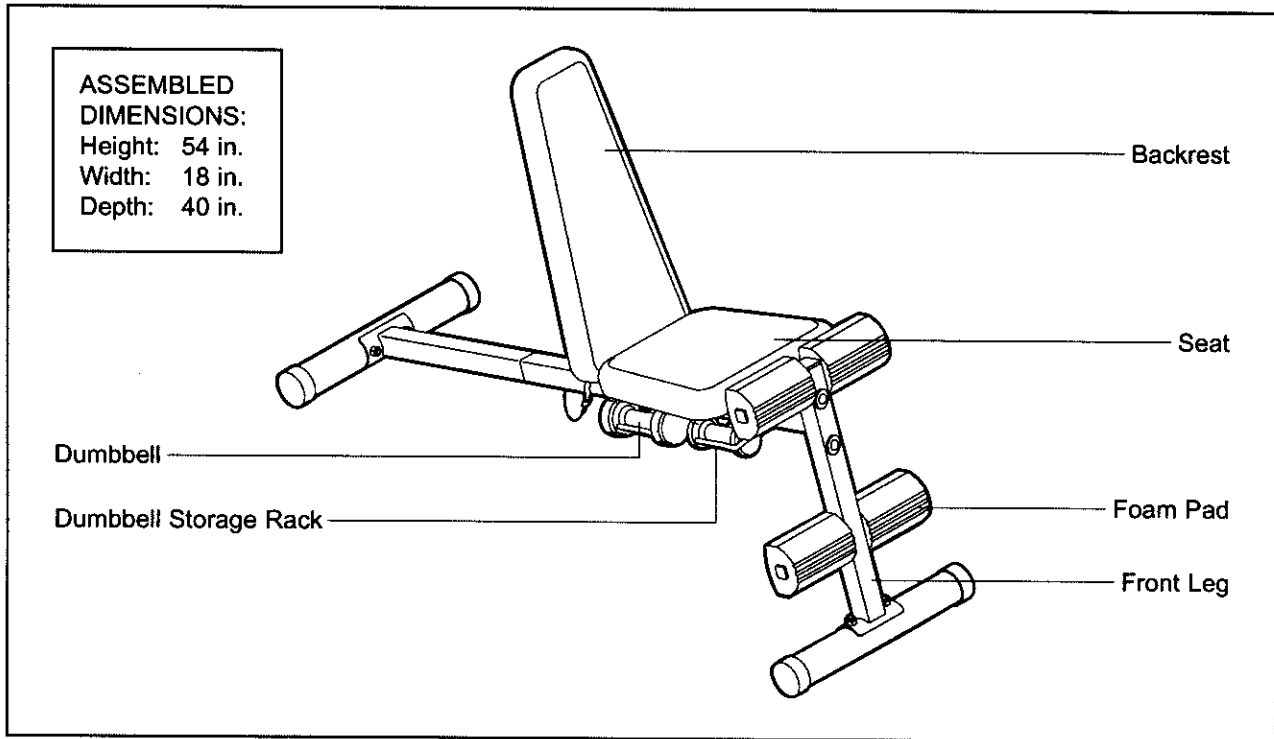

PART IDENTIFICATION CHART

Refer to the drawings below to identify small parts used in assembly. The number in parentheses by each drawing is the key number of the part, from the PART LIST on page 11 of this manual. **Note: Some parts may have been pre-assembled for shipping purposes. If you cannot find a part in the parts bags, check to see if it has been pre-assembled. If a part is missing, call toll-free 1-800-999-3756.**

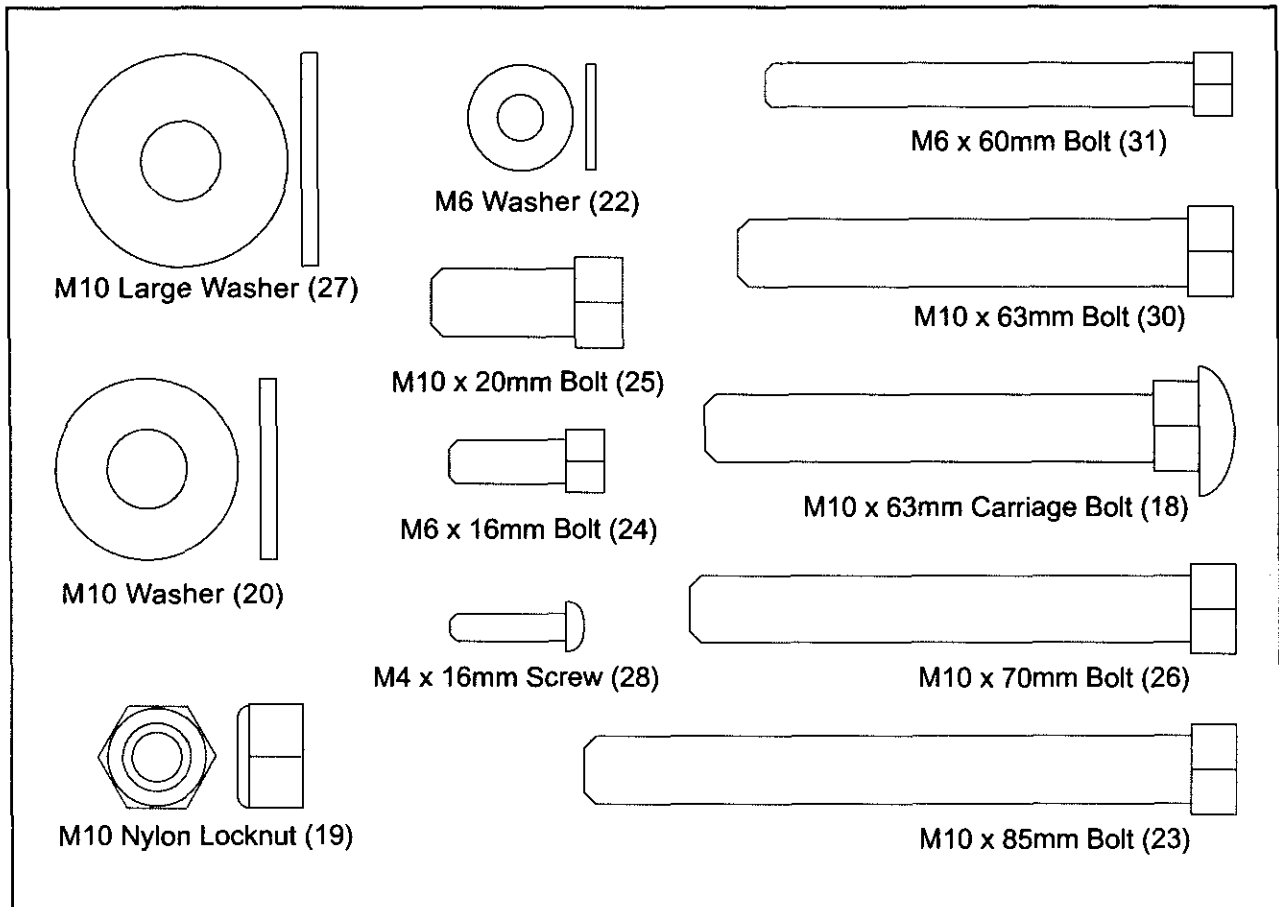

ASSEMBLY

Make Things Easier for Yourself



This manual is designed to ensure that the weight bench can be assembled successfully by anyone. Most people find that by setting aside plenty of time, assembly will go smoothly.

Before beginning assembly, carefully read the following information and instructions:

- Assembly requires two people.
- For help identifying small parts, use the **PART IDENTIFICATION CHART** on page 5.
- Tighten all parts as you assemble them, unless instructed to do otherwise.
- As you assemble the weight bench, make sure all parts are oriented as shown in the drawings.

- Place all parts in a cleared area and remove the packing materials. Do not dispose of the packing materials until assembly is completed.

The following tools (not included) are required for assembly:

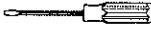
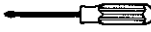
- Two adjustable wrenches 
- One rubber mallet 
- One standard screwdriver 
- One Phillips screwdriver 
- Lubricant, such as grease or petroleum jelly, and soapy water.

Assembly will be more convenient if you have a socket set, a set of open-end or closed-end wrenches, or a set of ratchet wrenches.

1. Before assembling the weight bench, make sure that you understand the information in the box above.

Press a 45mm Square Inner Cap (14) into the top of the Front Leg (2). Press two 50mm Round Outer Caps (12) onto the ends of the Black Stabilizer (29).

Attach the Black Stabilizer (29) to the Front Leg (2) with two M10 x 63mm Carriage Bolts (18) and two M10 Nylon Locknuts (19). Be sure the indents in the Stabilizer and the name decal on the Front Leg are in the positions shown. Do not tighten the Locknuts yet.

2. Press four 50mm Square Inner Caps (13) into the tubes on the Frame (1). Make sure the slots on the Caps are vertical to accommodate the Screws (not shown) that will attach the Seat (not shown) to the Frame.

Attach the Frame (1) to the Front Leg (2) with two M10 x 63mm Bolts (30), two M10 Large Washers (27), and two M10 Nylon Locknuts (19). Do not tighten the Locknuts yet.

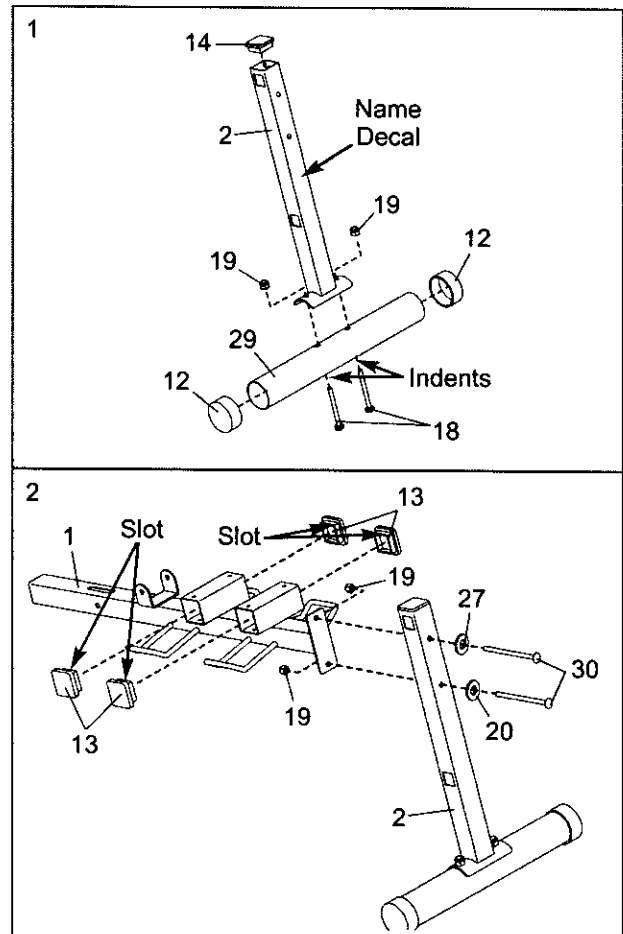

- Press two 50mm Round Outer Caps (12) onto the ends of the Silver Stabilizer (4).

Attach the Silver Stabilizer (4) to the Rear Leg (3) with two M10 x 63mm Carriage Bolts (18) and two M10 Nylon Locknuts (19). **Be sure the indents, the warning decal, and the Rear Leg are oriented as shown. Do not tighten the Locknuts yet.**

Attach the Rear Leg (3) to the Frame (1) with two M10 x 20mm Bolts (25) and two M10 Washers (20).

Tighten the M10 Nylon Locknuts (19) used in steps 1-3.

- Press two 25mm Square Inner Caps (11) into a Pad Tube (10).

Slide the Pad Tube (10) into the Front Leg (2). Wet the ends of the Pad Tube with soapy water. Slide two Foam Pads (9) onto the ends of the Pad Tube.

Repeat this step with the other Pad Tube (10).

- Press a 25mm x 50mm Inner Cap (15) into the Backrest Frame (5).

Attach the Pivot Bracket (6) to the Backrest Frame (5) with two M10 x 70mm Bolts (26) and two M10 Nylon Locknuts (19). **Do not tighten the Locknuts yet.**

Insert the Pivot Bracket (6) into the slot in the Frame (1).

- Lubricate the M10 x 85mm Bolt (23) with grease. Attach the Backrest Frame (5) to the Frame (1) with the Bolt and an M10 Nylon Locknut (19). **Do not overtighten the Locknut; the Backrest Frame must be able to pivot easily.**

Attach the tether on the Locking Pin (21) to the bottom of the Frame (1) with the M4 x 16mm Screw (28).

Insert the Locking Pin (21) into the Frame (1) and through an adjustment hole in the Pivot Bracket (6).

See the inset drawing. Attach an M10 x 20mm Bolt (25) and an M10 Nylon Locknut (19) to the last hole in the Pivot Bracket (6).

Tighten the M10 Nylon Locknuts (19) used in step 5.

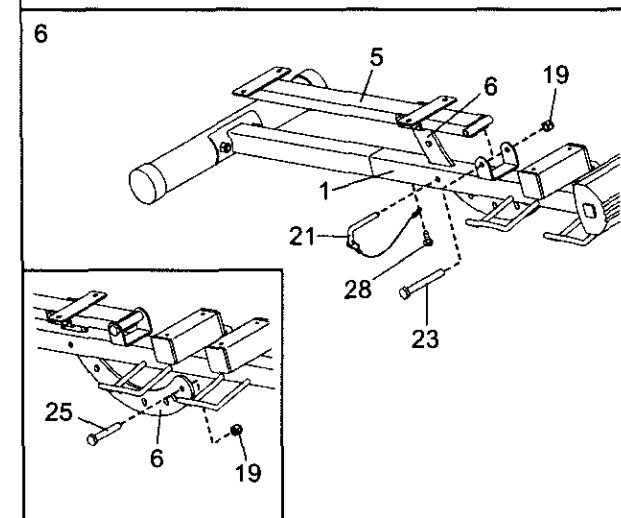
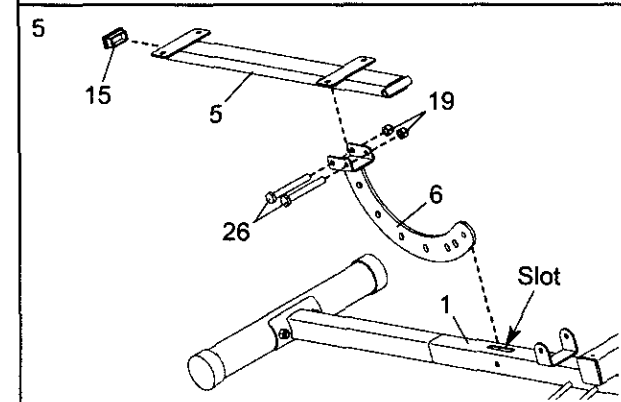
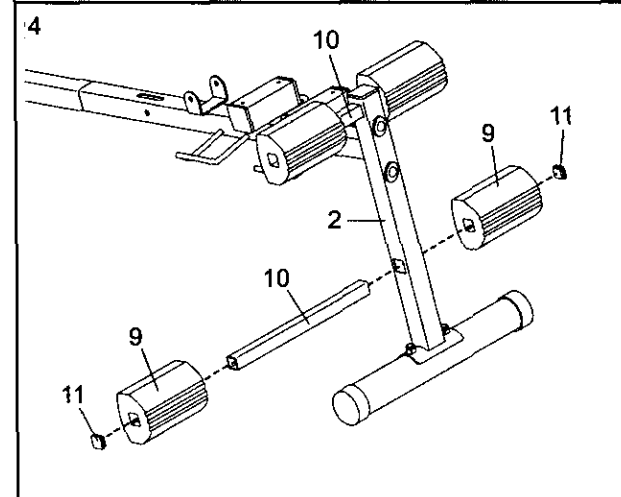
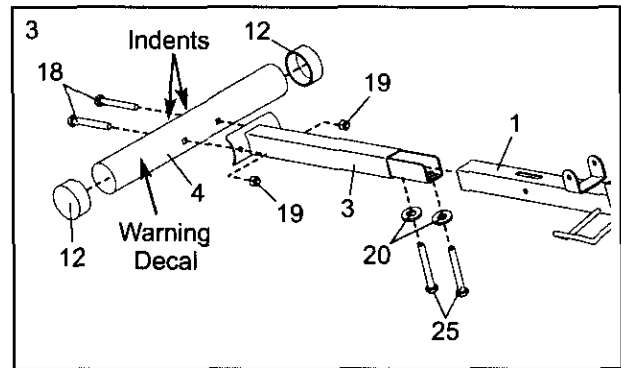

- Attach the Backrest (7) to the Backrest Frame (5) with four M6 x 16mm Bolts (24). **Be sure the Backrest is oriented as shown.**

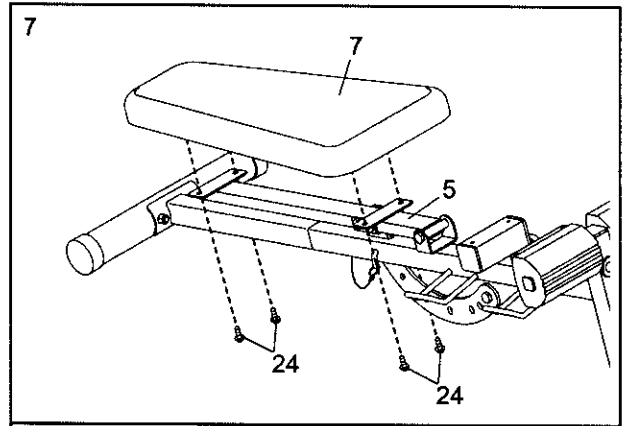

- Attach the Seat (8) to the Frame (1) with four M6 x 60mm Bolts (31) and four M6 Washers (22). **Be sure the wide end of the Seat is on the side shown.**

Set the Dumbbells (not shown) onto the dumbbell storage racks on the Frame (1).

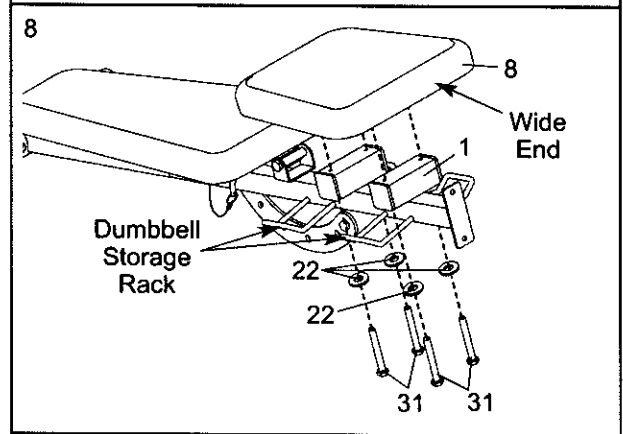

- Make sure all parts are properly tightened before you use the weight bench.**

ADJUSTMENTS

This section explains how to adjust the weight bench. See the EXERCISE GUIDELINES on page 9 for important information about how to get the most benefit from your exercise program. Also, refer to the accompanying exercise guide to see the correct form for each exercise.

Make sure all parts are properly tightened each time the weight bench is used. Replace any worn parts immediately. The weight bench can be cleaned with a damp cloth and a mild, non-abrasive detergent. Do not use solvents.

ADJUSTING THE BACKREST

The Backrest (7) can be used in a declined, a level, or any of four inclined positions. To adjust the Backrest, remove the Locking Pin (21) from the Frame (1). Move the Backrest to the desired position and reinsert the Locking Pin into the Frame and an adjustment hole in the Pivot Bracket (6).

⚠ WARNING: Always make sure the Locking Pin (21) is fully inserted through the Frame (1) and the Pivot Bracket (6).

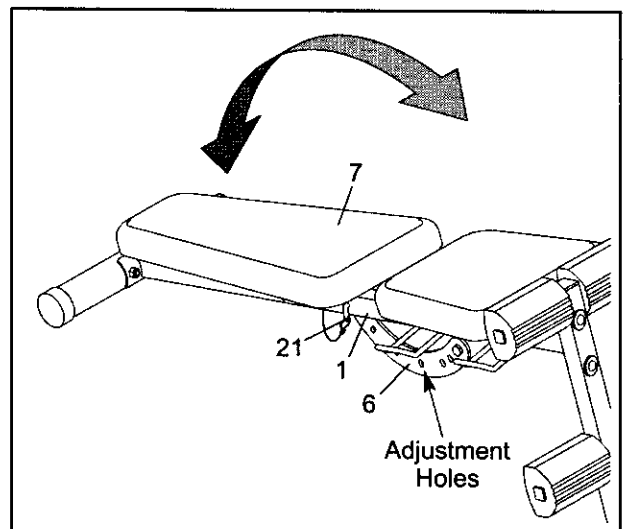

EXERCISE GUIDELINES

THE FOUR BASIC TYPES OF WORKOUTS

Muscle Building

To increase the size and strength of your muscles, push them close to their maximum capacity. Your muscles will continually adapt and grow as you progressively increase the intensity of your exercise. You can adjust the intensity level of an individual exercise in two ways:

- by changing the amount of resistance used
- by changing the number of repetitions or sets performed. (A “repetition” is one complete cycle of an exercise, such as one sit-up. A “set” is a series of repetitions.)

The proper amount of resistance for each exercise depends upon the individual user. You must gauge your limits and select the amount of resistance that is right for you. Begin with 3 sets of 8 repetitions for each exercise you perform. Rest for 3 minutes after each set. When you can complete 3 sets of 12 repetitions without difficulty, increase the amount of resistance.

Toning

You can tone your muscles by pushing them to a moderate percentage of their capacity. Select a moderate amount of resistance and increase the number of repetitions in each set. Complete as many sets of 15 to 20 repetitions as possible without discomfort. Rest for 1 minute after each set. Work your muscles by completing more sets rather than by using high amounts of resistance.

Weight Loss

To lose weight, use a low amount of resistance and increase the number of repetitions in each set. Exercise for 20 to 30 minutes, resting for a maximum of 30 seconds between sets.

Cross Training

Cross training is an efficient way to get a complete and well-balanced fitness program. An example of a balanced program is:

- Plan strength training workouts on Monday, Wednesday, and Friday.
- Plan 20 to 30 minutes of aerobic exercise, such as running on a treadmill or riding on an elliptical or exercise bike, on Tuesday and Thursday.
- Rest from both strength training and aerobic exercise for at least one full day each week to give your body time to regenerate.

The combination of strength training and aerobic exercise will reshape and strengthen your body, plus develop your heart and lungs.

PERSONALIZING YOUR EXERCISE PROGRAM

Determining the exact length of time for each workout, as well as the number of repetitions or sets completed, is an individual matter. It is important to avoid overdoing it during the first few months of your exercise program. You should progress at your own pace and be sensitive to your body's signals. If you experience pain or dizziness at any time while exercising, stop immediately and begin cooling down. Find out what is wrong before continuing. Remember that adequate rest and a proper diet are important factors in any exercise program.

WARMING UP

Begin each workout with 5 to 10 minutes of stretching and light exercise to warm up. Warming up prepares your body for more strenuous exercise by increasing circulation, raising your body temperature and delivering more oxygen to your muscles.

WORKING OUT

Each workout should include 6 to 10 different exercises. Select exercises for every major muscle group, emphasizing areas that you want to develop most. To give balance and variety to your workouts, vary the exercises from session to session.

Schedule your workouts for the time of day when your energy level is the highest. Each workout should be followed by at least one day of rest. Once you find the schedule that is right for you, stick with it.

EXERCISE FORM

Maintaining proper form is an essential part of an effective exercise program. This requires moving through the full range of motion for each exercise, and moving only the appropriate parts of the body. Exercising in an uncontrolled manner will leave you feeling exhausted. On the exercise guide accompanying this manual you will find photographs showing the correct form for several exercises, and a list of the muscles affected. Refer to the muscle chart on the next page to find the names of the muscles.

The repetitions in each set should be performed smoothly and without pausing. The exertion stage of each repetition should last about half as long as the return stage. Proper breathing is important. Exhale during the exertion stage of each repetition and inhale during the return stroke. Never hold your breath.

Rest for a short period of time after each set. The ideal resting periods are:

- Rest for three minutes after each set for a muscle building workout.
- Rest for one minute after each set for a toning workout.
- Rest for 30 seconds after each set for a weight loss workout.

Plan to spend the first couple of weeks familiarizing yourself with the equipment and learning the proper form for each exercise.

COOLING DOWN

End each workout with 5 to 10 minutes of stretching. Include stretches for both your arms and legs. Move

slowly as you stretch and do not bounce. Ease into each stretch gradually and go only as far as you can without strain. Stretching at the end of each workout is an effective way to increase flexibility.

STAYING MOTIVATED

For motivation, keep a record of each workout. List the date, the exercises performed, the resistance used, and the numbers of sets and repetitions completed. Record your weight and key body measurements at the end of every month. Remember, the key to achieving the greatest results is to make exercise a regular and enjoyable part of your everyday life.

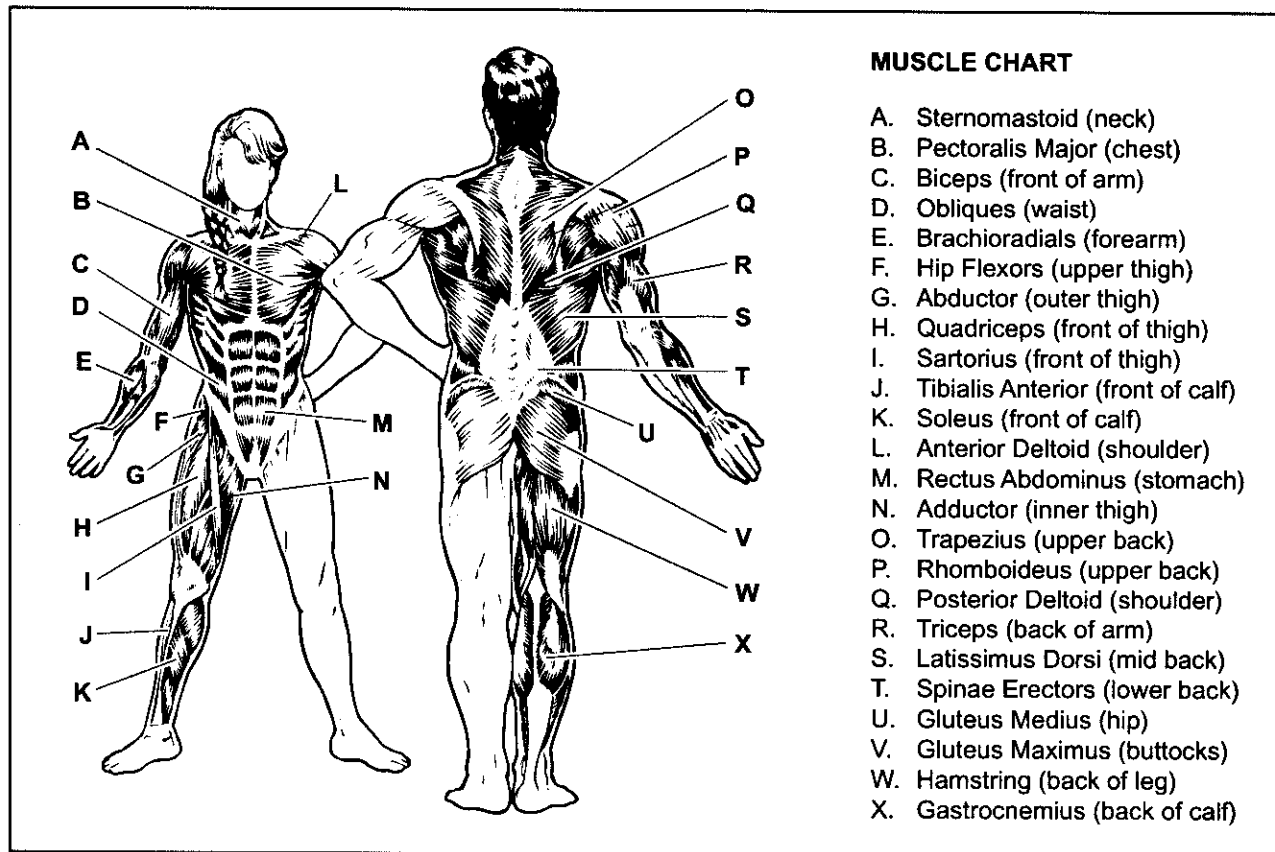

PART LIST/EXPLODED DRAWING—Model No. 831.150260

R0703A

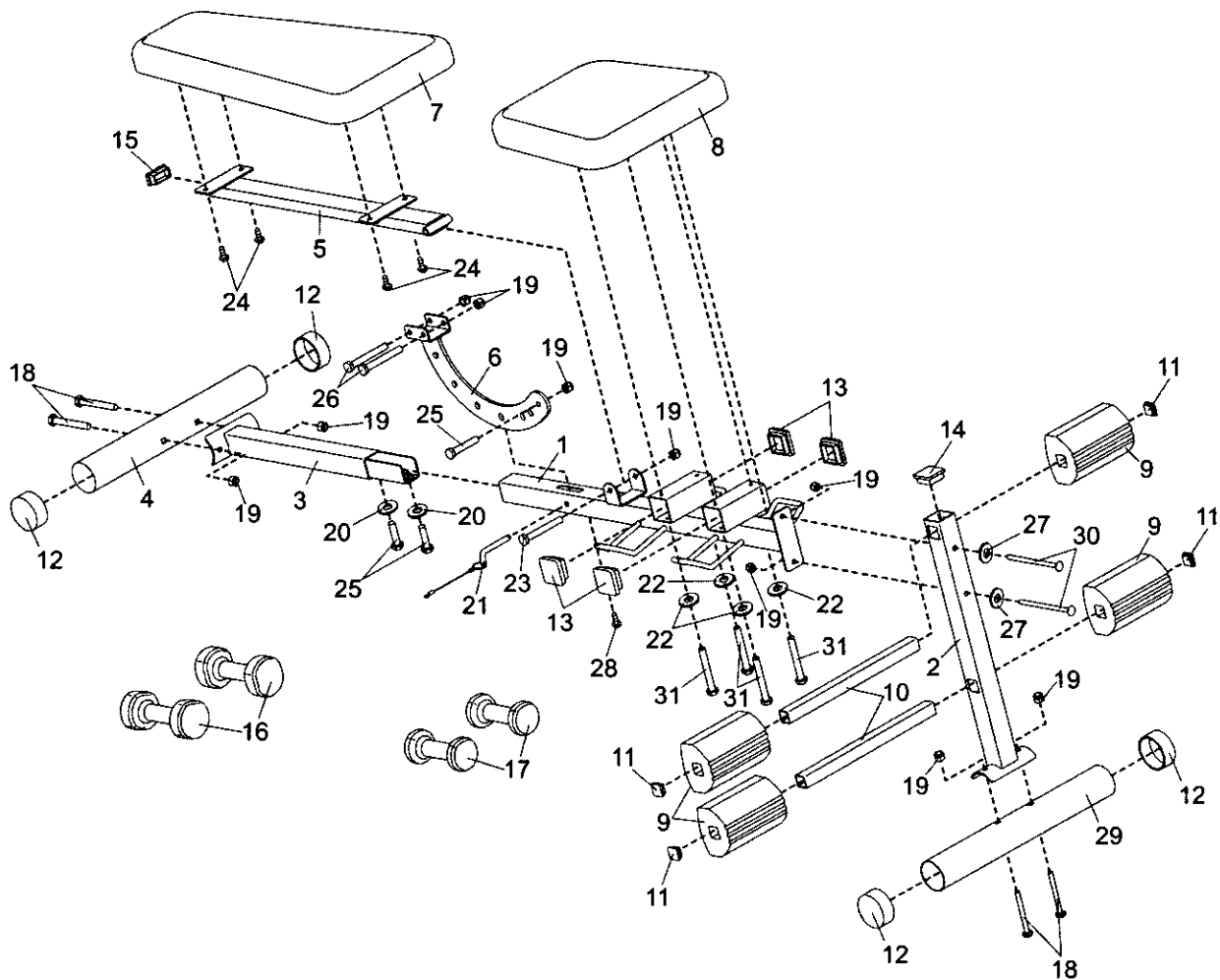

Key No.	Qty.	Description	Key No.	Qty.	Description
1	1	Frame	18	4	M10 x 63mm Carriage Bolt
2	1	Front Leg	19	10	M10 Nylon Locknut
3	1	Rear Leg	20	2	M10 Washer
4	1	Silver Stabilizer	21	1	Locking Pin
5	1	Backrest Frame	22	4	M6 Washer
6	1	Pivot Bracket	23	1	M10 x 85mm Bolt
7	1	Backrest	24	4	M6 x 16mm Bolt
8	1	Seat	25	3	M10 x 20mm Bolt
9	4	Foam Pad	26	2	M10 x 70mm Bolt
10	2	Pad Tube	27	2	M10 Large Washer
11	4	25mm Square Inner Cap	28	1	M4 x 16mm Screw
12	4	50mm Round Outer Cap	29	1	Black Stabilizer
13	4	50mm Square Inner Cap	30	2	M10 x 63mm Bolt
14	1	45mm Square Inner Cap	31	4	M6 x 60mm Bolt
15	1	25mm x 50mm Inner Cap	#	1	User's Manual
16	2	5-pound Dumbbell	#	1	Exercise Guide
17	2	3-pound Dumbbell	#	1	Grease Pack

Note: “#” indicates a non-illustrated part. Specifications are subject to change without notice. See the back cover of this manual for information about ordering replacement parts. If a part is missing, call toll-free 1-800-999-3756.

Get it fixed, at your home or ours!

Your Home

For repair – **in your home** – of **all** major brand appliances, lawn and garden equipment, or heating and cooling systems, **no matter who made it, no matter who sold it!**

For the replacement parts, accessories, and user's manuals that you need to do-it-yourself.

For Sears professional installation of home appliances and items like garage door openers and water heaters.

1-800-4-MY-HOME®

(1-800-469-4663)

www.sears.com

Anytime, day or night

(U.S.A. and Canada)

www.sears.ca

Our Home

For repair of carry-in products like vacuums, lawn equipment, and electronics, call or go on-line for the location of your nearest **Sears Parts and Repair Center.**

1-800-488-1222 Anytime, day or night (U.S.A. only)

www.sears.com

To purchase a protection agreement (U.S.A.) or maintenance agreement (Canada) on a product serviced by Sears:

1-800-827-6655 (U.S.A.)

1-800-361-6665 (Canada)

Para pedir servicio de reparación a domicilio, y para ordenar piezas:

1-888-SU-HOGARSM (1-888-784-6427)

SEARS

® Registered Trademark / ™ Trademark / SM Service Mark of Sears, Roebuck and Co.
© Marca Registrada / ™ Marca de Fábrica / SM Marca de Servicio de Sears, Roebuck and Co.

FULL 90 DAY WARRANTY

For 90 days from the date of purchase, if failure occurs due to defect in material or workmanship in this **WEIGHT BENCH EXERCISER**, contact the nearest Sears Service Center throughout the United States and Sears will repair or replace the **WEIGHT BENCH EXERCISER**, free of charge.

This warranty does not apply when the **WEIGHT BENCH EXERCISER** is used commercially or for rental purposes.

This warranty gives you specific legal rights, and you may also have other rights which vary from state to state.

Sears, Roebuck and Co., Dept 817WA, Hoffman Estates, IL 60179