

PRO-FORM® 4800

Model No. 831.150330

Serial No. _____

Write the serial number in the space above for reference.

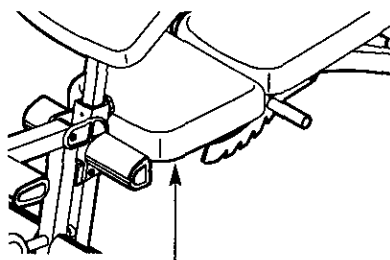

Serial Number Decal (under seat)

- Assembly
- Adjustments
- Part List and Drawing

▲ CAUTION

Read all precautions and instructions in this manual before using this equipment. Save this manual for future reference.

WEIGHT BENCH EXERCISER User's Manual

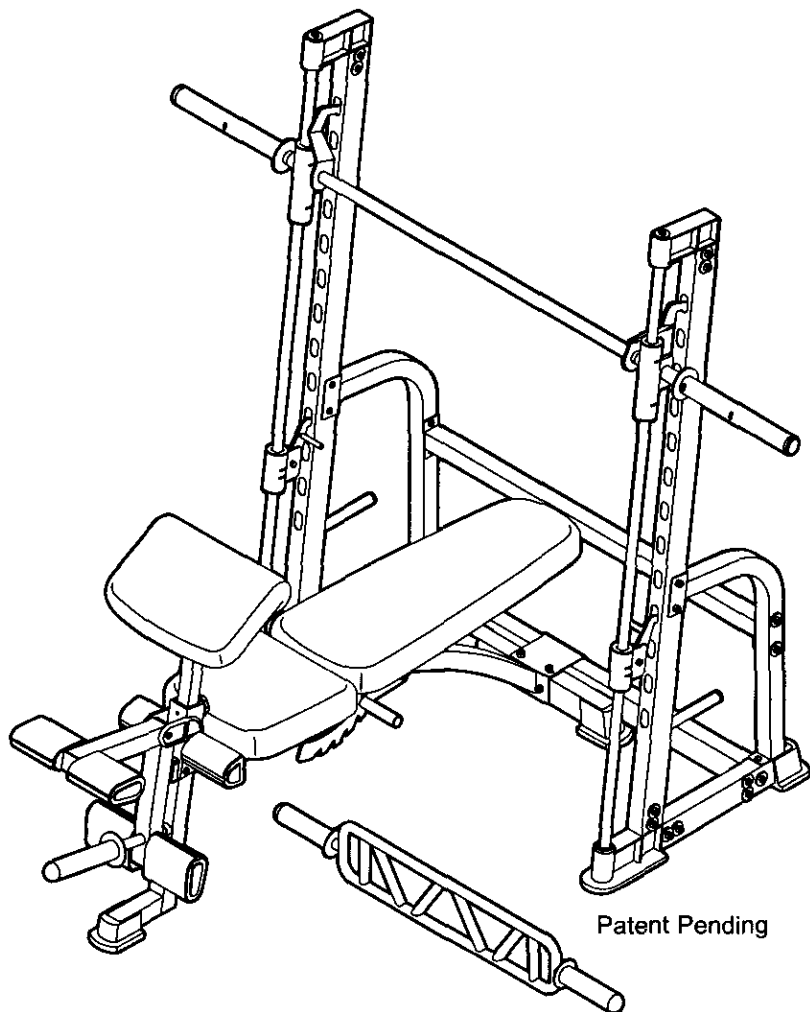

Sears, Roebuck and Co., Hoffman Estates, IL 60179

TABLE OF CONTENTS

WARNING DECAL PLACEMENT	2
IMPORTANT PRECAUTIONS	3
BEFORE YOU BEGIN	4
ASSEMBLY	5
ADJUSTMENTS	12
EXERCISE GUIDELINES	15
ORDERING REPLACEMENT PARTS	Back Cover
FULL 90-DAY WARRANTY	Back Cover

Note: A PART IDENTIFICATION CHART and a PART LIST/EXPLODED DRAWING is attached in the center of this manual. Remove the PART IDENTIFICATION CHART and PART LIST/EXPLODED DRAWING before beginning assembly.

WARNING DECAL PLACEMENT

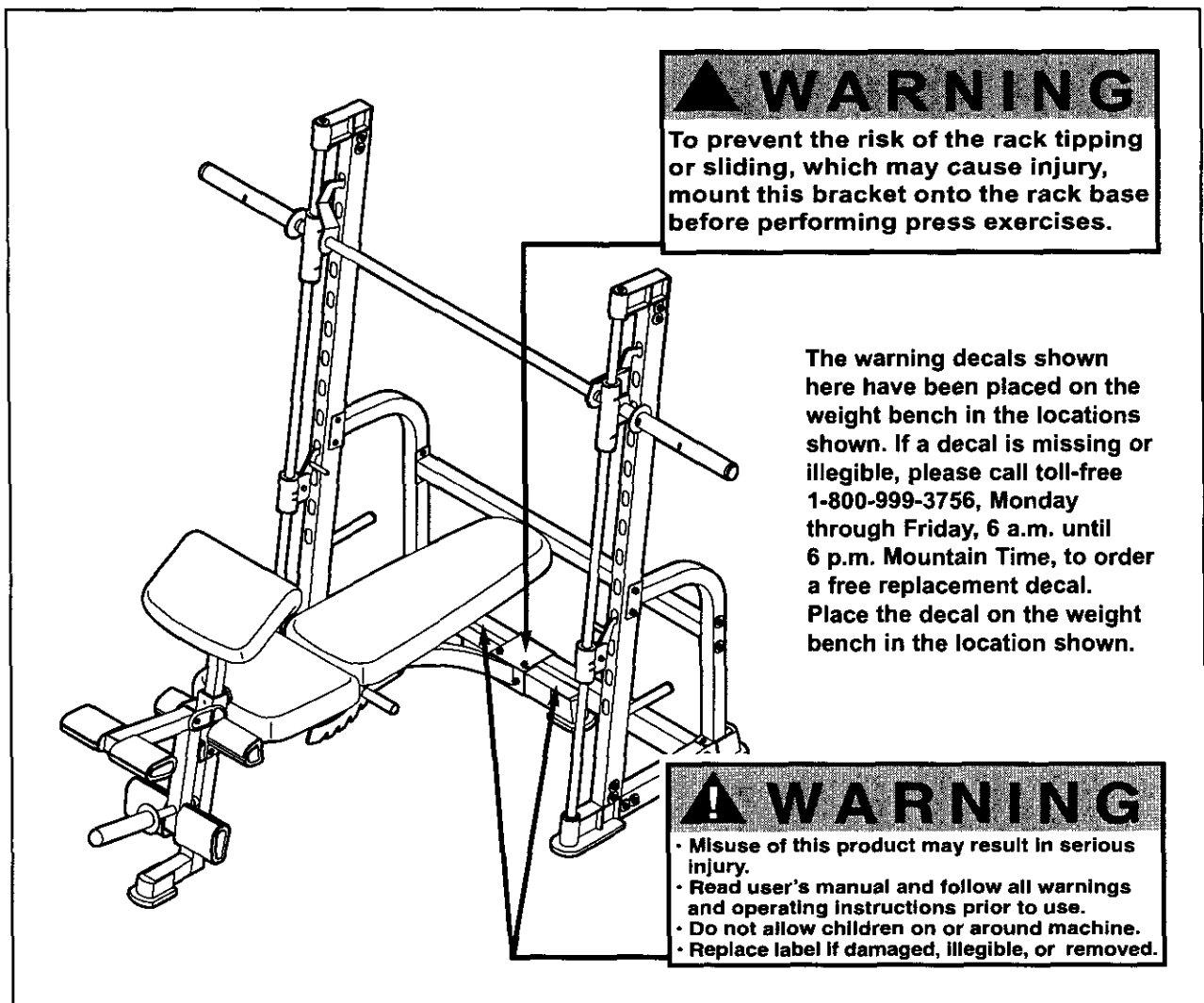

IMPORTANT PRECAUTIONS

▲ WARNING: To reduce the risk of serious injury, read the following important precautions before using the weight bench.

1. Read all instructions in this manual before using the weight bench. Use the weight bench only as described in this manual.
2. It is the responsibility of the owner to ensure that all users of the weight bench are adequately informed of all precautions.
3. The weight bench is intended for home use only. Do not use the weight bench in any commercial, rental, or institutional setting.
4. Use the weight bench only on a level surface. Cover the floor beneath the weight bench to protect the floor.
5. Make sure all parts are properly tightened each time the weight bench is used. Replace any worn parts immediately.
6. Keep children under 12 and pets away from the weight bench at all times.
7. Keep hands and feet away from moving parts.
8. Always wear athletic shoes for foot protection while exercising.
9. Use the curl bar only with the weight clips provided with the bench.
10. Always set both barbell guides and both safety spotters at the same height.
11. Make sure that the set screws attaching the Olympic weight adapters are properly tightened each time the adapters are used.
12. The weight bench is designed to support a maximum user weight of 300 pounds and a maximum total weight of 610 pounds. Do not place more than 310 pounds on the barbell or safety spotters. Do not place more than 150 pounds on the leg lever or curl bar. Note: The weight bench does not include weights.
13. Always place an equal amount of weight on each side of the barbell.
14. Always secure the weights with the weight clips when they are mounted on the barbell.
15. Always make sure the backrest bracket is fully engaged before using the backrest.
16. Always mount the "L"-bracket onto the center base before performing press exercises.
17. Always move your bench out of the way when performing an exercise that does not use the bench.
18. If you feel pain or dizziness at any time while exercising, stop immediately and begin cooling down.

▲ WARNING: Before beginning this or any exercise program, consult your physician. This is especially important for persons over the age of 35 or persons with pre-existing health problems. Read all instructions before using. Sears assumes no responsibility for personal injury or property damage sustained by or through the use of this product.

BEFORE YOU BEGIN

Thank you for selecting the versatile PROFORM® C800 weight bench. The weight bench offers an impressive array of weight stations designed to develop every major muscle group of the body. Whether your goal is to tone your body, build dramatic muscle size and strength, or improve your cardiovascular system, the weight bench will help you to achieve the specific results you want.

For your benefit, read this manual carefully before using the weight bench. If you have questions after

reading this manual, call 1-800-4-MY-HOME® (1-800-469-4663). To help us assist you, please note the product model number and serial number before calling. The model number is 831.150330. The serial number can be found on a decal attached to the weight bench (see the front cover of this manual for the location of the decal).

Before reading further, please review the drawing below and familiarize yourself with the parts that are labeled.

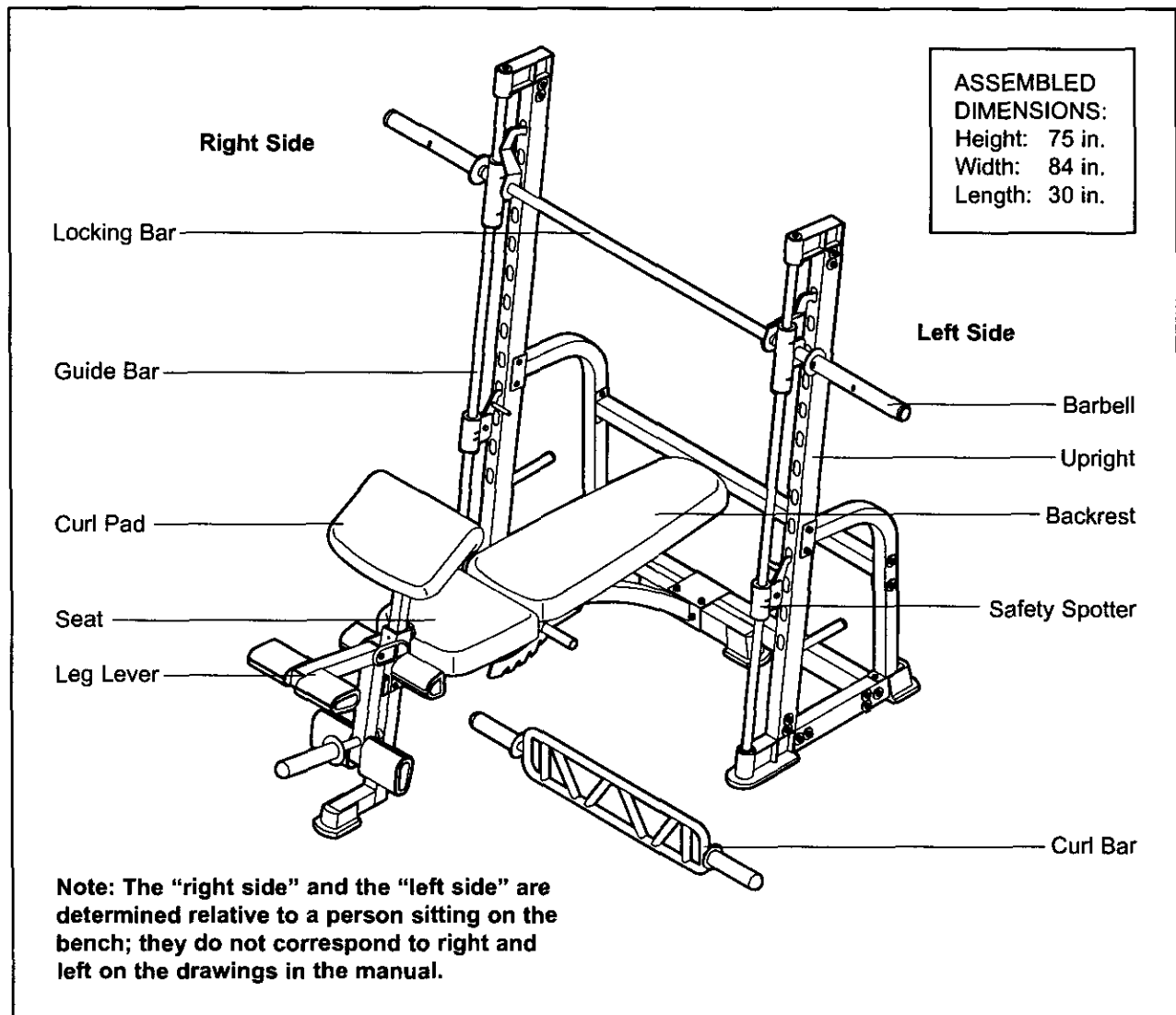

ASSEMBLY

Make Things Easier for Yourself



This manual is designed to ensure that the weight bench can be assembled successfully by anyone. Most people find that by setting aside plenty of time, assembly will go smoothly.

Before beginning assembly, carefully read the following information and instructions:

- Assembly requires two people.
- **For help identifying small parts, use the PART IDENTIFICATION CHART.**
- Tighten all parts as you assemble them, unless instructed to do otherwise.
- As you assemble the weight bench, make sure all parts are oriented as shown in the drawings.

- Place all parts in a cleared area and remove the packing materials. Do not dispose of the packing materials until assembly is completed.

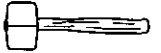
The following tools (not included) are required for assembly:

- Two adjustable wrenches 
- One rubber mallet 
- One standard screwdriver 
- One Phillips screwdriver 
- Lubricant, such as grease or petroleum jelly, and soapy water.

Assembly will be more convenient if you have a socket set, a set of open-end or closed-end wrenches, or a set of ratchet wrenches.

1. Before beginning, make sure you understand the information in the box above. Note: Some parts described in the assembly steps may be pre-assembled.

Press a Notched Square Inner Cap (18) into the end of the Bench Frame (1). Attach a Base Cap (9) to the Stabilizer (2) with an M4 x 16mm Screw (58) and an M10 x 25mm Button Screw (78). Attach another Base Cap to the Stabilizer in the same manner.

Attach the Stabilizer (2) and the "L"-bracket (76) to the Bench Frame (1) with two M10 x 95mm Carriage Bolts (61) and two M10 Nylon Locknuts (69). Secure the Stabilizer to the Bench Frame with two M10 x 68mm Button Bolts (79), two M10 Washers (67), and two M10 Nylon Locknuts. Do not tighten the Locknuts yet.

2. Press a Thin Notched Square Inner Cap (86) into the bottom of the Bench Leg (3). Attach the Small Base Cap (80) to the Bench Leg with an M4 x 16mm Screw (58).

Attach the Bench Leg (3) to the Bench Frame (1) with two M10 x 68mm Button Bolts (79), two M10 Washers (67), and two M10 Nylon Locknuts (69).

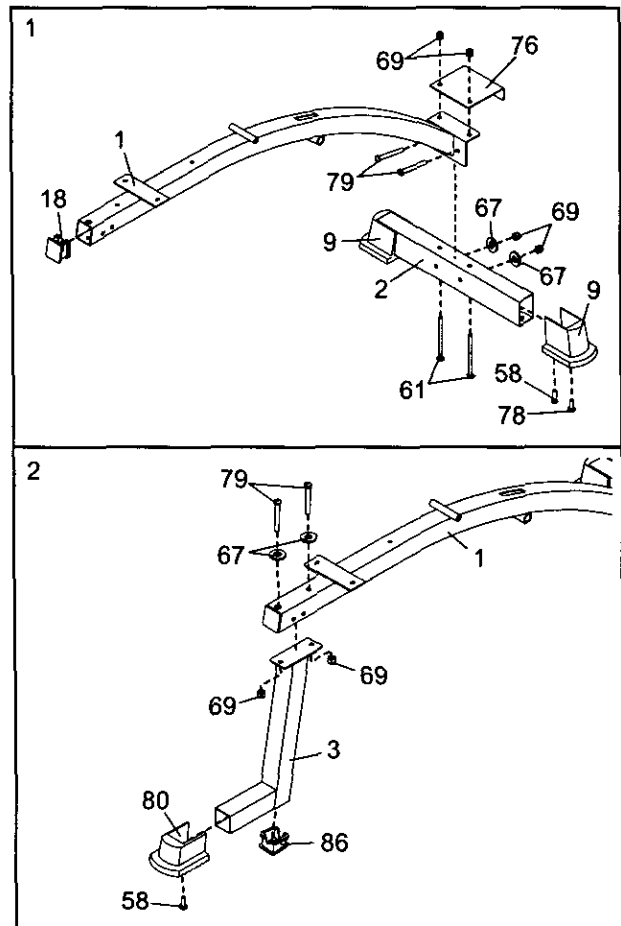

- Attach the Leg Lever Bracket (7) to the Bench Frame (1) with two M10 x 81mm Button Bolts (75) and two M10 Nylon Locknuts (69).

Press two 50mm Square Inner Caps (17) into the Leg Lever (4). Press a 25mm Round Inner Cap (20) into the indicated end of the Weight Tube (11).

Attach the Weight Tube (11) to the Leg Lever (4) with an M8 x 63mm Button Bolt (71), two M8 Washers (73), a 13mm Spacer (25), and an M8 Nylon Locknut (72).

Press a 25mm Round Angled Cap (24) onto the Weight Tube (11).

Lubricate the M10 x 73mm Button Bolt (70) with grease. Attach the Leg Lever (4) to the Leg Lever Bracket (7) with the Bolt and an M10 Nylon Locknut (69). **Do not overtighten the Locknut; the Leg Lever must be able to pivot easily.**

- Lubricate an M10 x 81mm Button Bolt (75) with grease. Attach the lower hole in the Adjustment Lever (8) to the Bench Frame (1) with the Bolt and an M10 Nylon Locknut (69). **Do not overtighten the Locknut; the Adjustment Lever must be able to pivot easily.**

Hold the handle on the Adjustment Lever (8) so that the upper hole is above the Bench Frame (1). Slide the M10 x 65mm Flat Head Screw (77) through the indicated side of the Lever, over the Bench Frame, and tighten it into the other side of the Adjustment Lever. **Make sure that the threads of the Screw show through the Adjustment Lever. Do not overtighten the Screw.**

- Press four 25mm Square Inner Caps (19) into the ends of the Backrest Tubes (6).

Attach the Backrest Bracket (10) to the Backrest Tubes (6) with four M10 x 45mm Button Bolts (74), four M10 Washers (67), and four M10 Nylon Locknuts (69). **Make sure the Backrest Tubes are oriented so that the indicated holes are closer to the bottom. Do not tighten the Locknuts yet.**

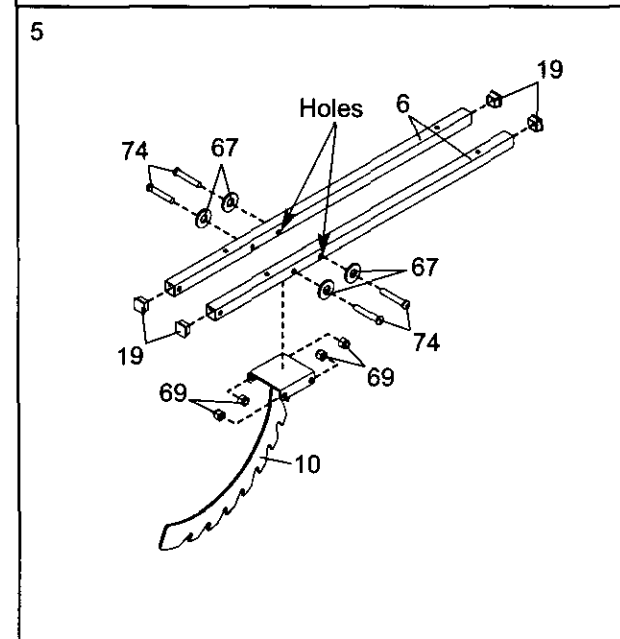
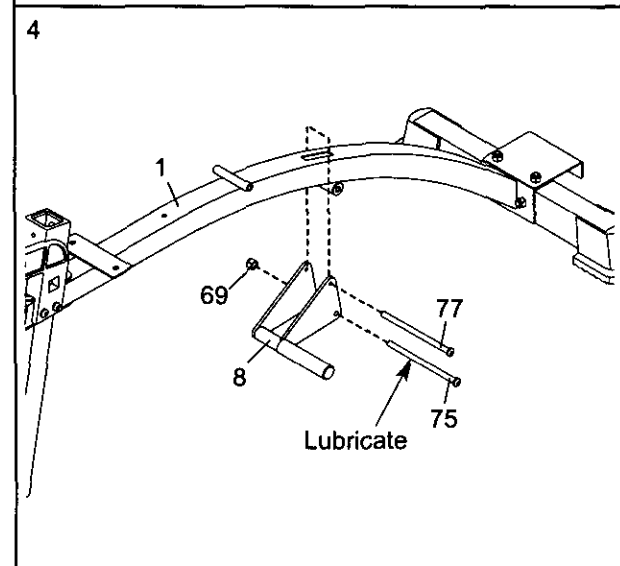
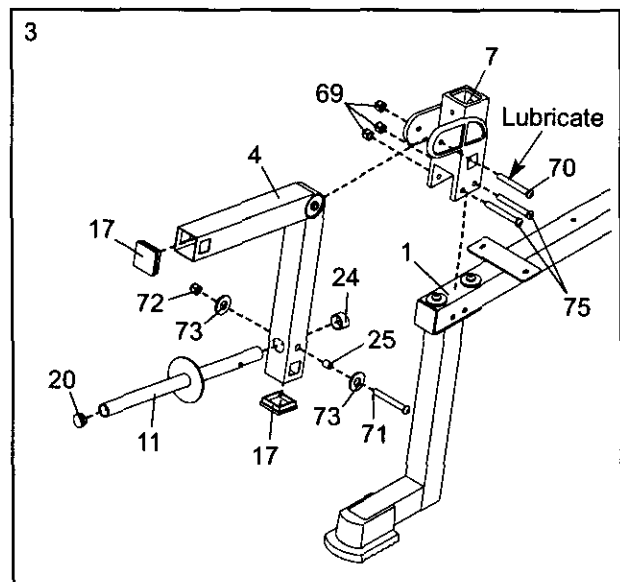

6. Insert the Backrest Bracket (10) through the slot in the Bench Frame (1) and under the Adjustment Lever (8). **Make sure that the M10 x 65mm Flat Head Screw (77) is under the Backrest Bracket arm.**

Lubricate an M10 x 155mm Button Bolt (85) with grease. Attach the Backrest Tubes (6) to the Bench Frame (1) with the Bolt, two M10 Washers (67), and an M10 Nylon Locknut (69). **Do not overtighten the Locknut; the Backrest Tubes must be able to pivot easily.**

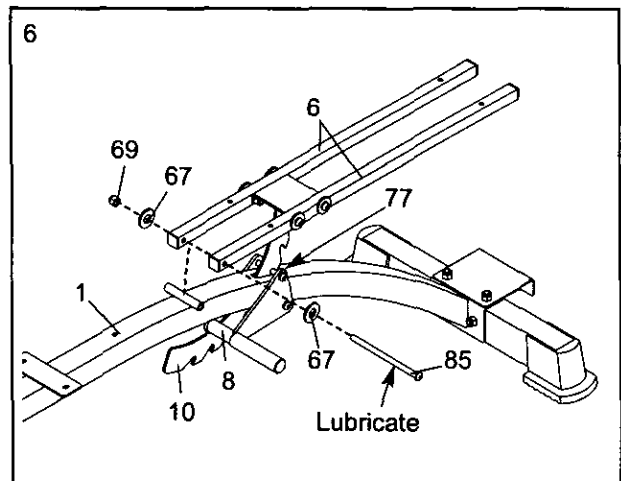

7. Attach the Backrest (12) to the Backrest Tubes (6) with four M6 x 38mm Screws (64) and four M6 Washers (68).

Tighten the four M10 Nylon Locknuts (69) used in step 5.

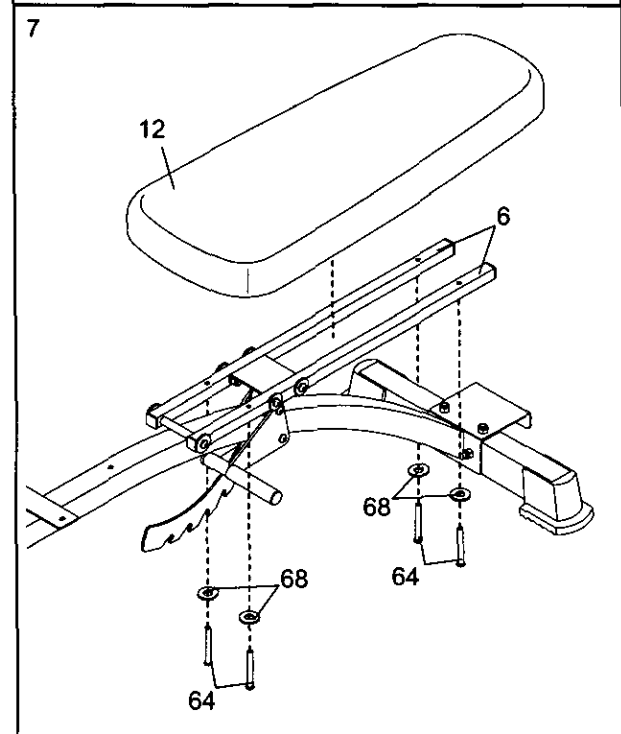

8. Attach the Seat (13) to the Bench Frame (1) with an M6 x 63mm Screw (65), an M6 Washer (68), and two M6 x 16mm Screws (63).

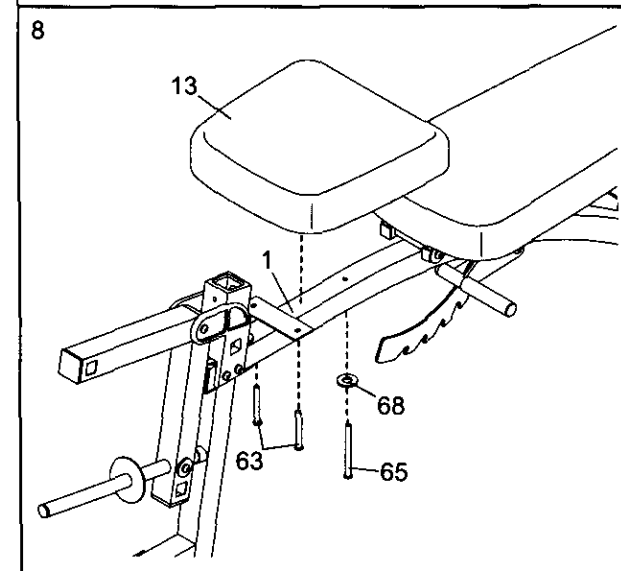

- Slide a Pad Tube (50) into a hole in the Leg Lever (4). Wet both sides of the Pad Tube with soapy water. Slide two Large Foam Pads (51) onto the Pad Tube as shown. Press two Large Pad Caps (53) into the Pad Tube. **Repeat with the other Pad Tube and the Leg Lever.**

Slide the Long Pad Tube (82) into the hole in the Leg Lever Bracket (7). Wet both sides of the Pad Tube with soapy water. Slide two Small Foam Pads (52) onto the Tube as shown. Press two Small Pad Caps (54) into the Pad Tube.

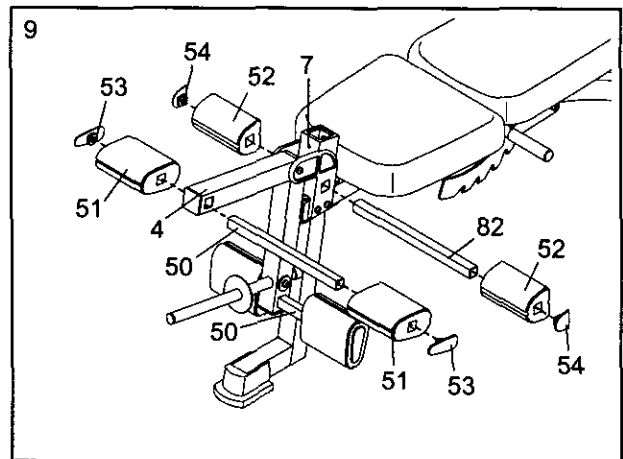

- Attach the Curl Pad (14) to the Curl Post (5) with two M6 x 16mm Screws (63).

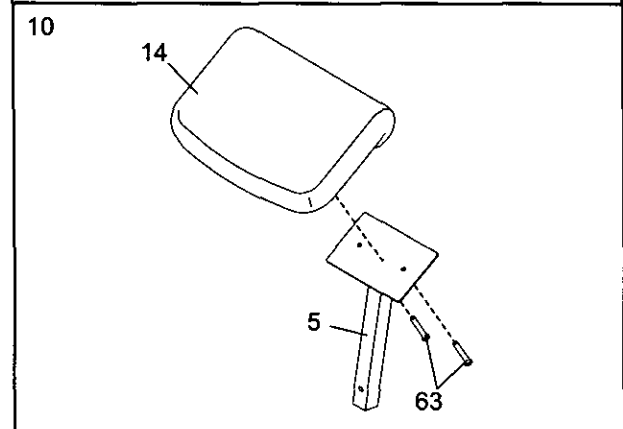

- Press a Round Angled Bushing (45) into a Rack Foot (35). Press a 25mm Round Inner Cap (20) into an Right Upright (62).

Attach a Guide Bar (32) to the Rack Foot (35) with an M10 x 30mm Button Screw (56) and an M10 Washer (67). **Tighten the Screw.**

Using a rubber mallet, tap the Right Upright (62), which has numbers on the indicated side, onto the Rack Foot (35). Attach the Right Upright to the Rack Foot with two M10 x 65mm Button Bolts (60), four M10 Washers (67), and two M10 Nylon Locknuts (69). **Make sure the Bolts are inserted from the side shown. Do not tighten the Locknuts yet.**

Repeat this step with the Left Upright (31 [not shown]), Guide Bar (32), and Rack Foot (35). Insert the M10 x 65mm Button Bolts (60) from the other side.

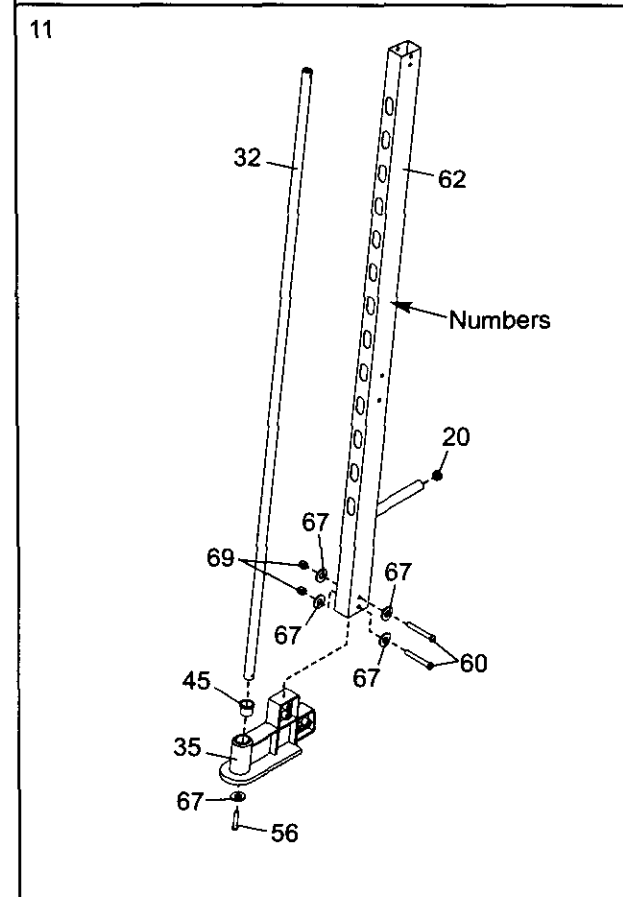

12. Attach a Base Cap (9) and a Rear Support (29) to the a Base (28) with two M10 x 93mm Button Bolts (48), an M10 Washer (67), an M10 Nylon Locknut (69), an M10 Nylon Jamnut (26), and an M4 x 16mm Screw (58).

Repeat this step with the other Base (28) and Rear Support (29).

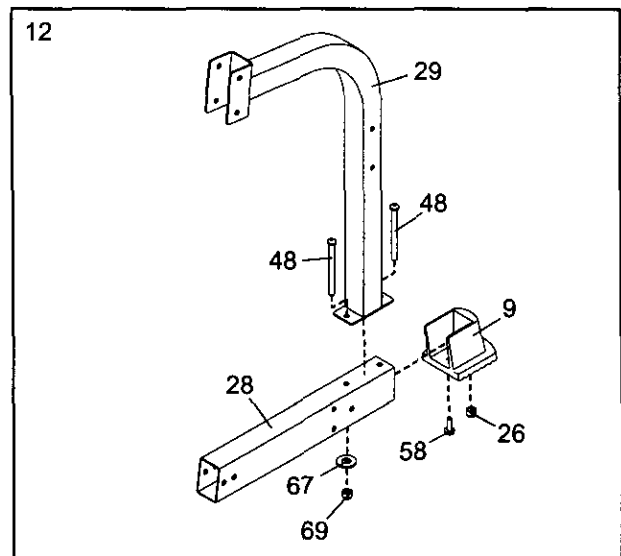

13. Attach a Base (28) to the Center Base (27) with three M10 x 68mm Button Bolts (79), three M10 Washers (67), and two M10 Nylon Locknuts (69). **Do not tighten the Locknuts yet.**

Attach the other Base (28) to the Center Base (27) in the same manner.

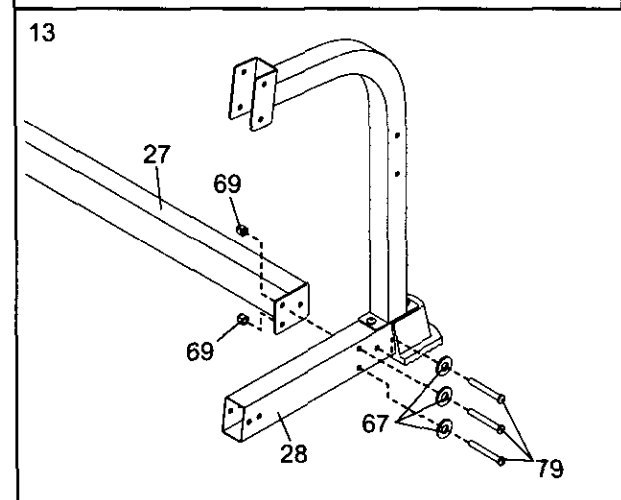

14. Attach the Crossbar (30) to a Rear Support (29) with two M10 x 68mm Button Bolts (79), two M10 Washers (67), and two M10 Nylon Locknuts (69). **Do not tighten the Locknuts yet.**

Attach the Crossbar (30) to the other Rear Support (29) in the same manner.

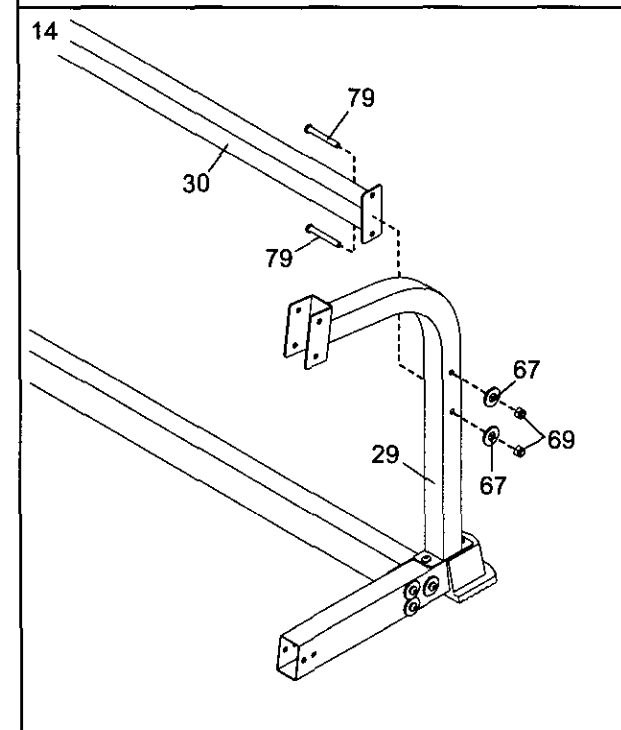

15. Using a rubber mallet, tap the left Rack Foot (35) into the indicated Base (28). Attach the Foot to the Base with two M10 x 65mm Button Bolts (60), four M10 Washers (67), and two M10 Nylon Locknuts (69). **Do not tighten the Locknuts yet.**

Attach the Left Upright (31) to the Rear Support (29) with two M10 x 68mm Button Bolts (79) and two M10 Nylon Locknuts (69). **Do not tighten the Locknuts yet.**

Attach the right Rack Foot (not shown) and Right Upright (not shown) in the same manner.

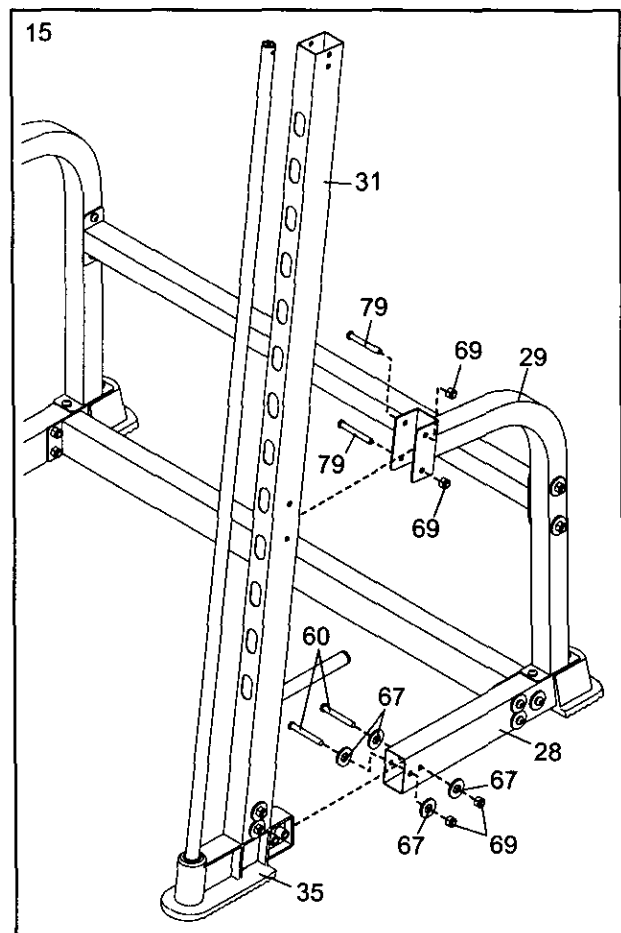

16. Attach the Right Spotter Hook (39) to a Safety Spotter (38) with an M8 x 12mm Shoulder Bolt (57) and an M8 Nylon Locknut (72). **Make sure the bolt head is on the same side as the handle.**

Slide the Safety Spotter (38) onto the right Guide Bar (32) and engage the Right Spotter Hook (39) into an adjustment hole near the bottom of the Right Upright (62).

Assemble the Left Spotter Hook (40) and a Safety Spotter (38) in the same manner.

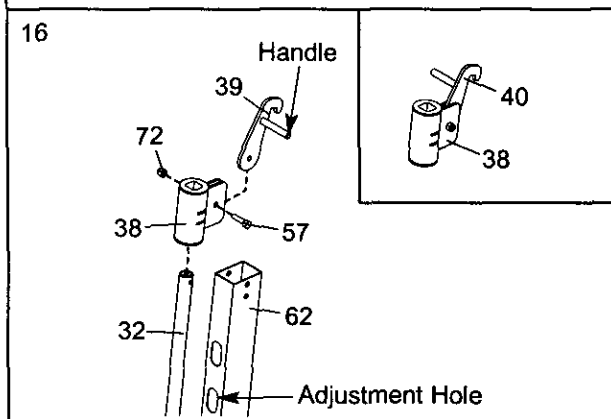

17. Identify the Left and Right Barbell Gliders (37, 81) by the position of the screw holes.

Slide each Barbell Glider (37, 81) onto the Guide Bar (32) next to the indicated Upright (31, 62). **Make sure the Barbell Gliders are oriented as shown.**

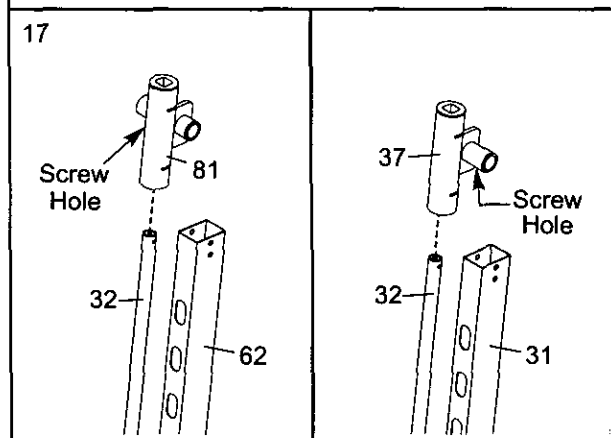

18. Press a Top Bracket Bushing (55) into the Top Bracket (36). Using a rubber mallet, tap the Top Bracket onto the Left Upright (31) and the Guide Bar (32).

Attach the Top Bracket (36) to the Left Upright (31) with two M10 x 65mm Button Bolts (60), four M10 Washers (67), and two M10 Nylon Locknuts (69). **Do not tighten the Locknuts yet.**

Attach the Top Bracket (36) to the Guide Bar (32) with an M10 x 30mm Button Screw (56) and an M10 Washer (67).

Assemble the other Top Bracket (36) in the same manner.

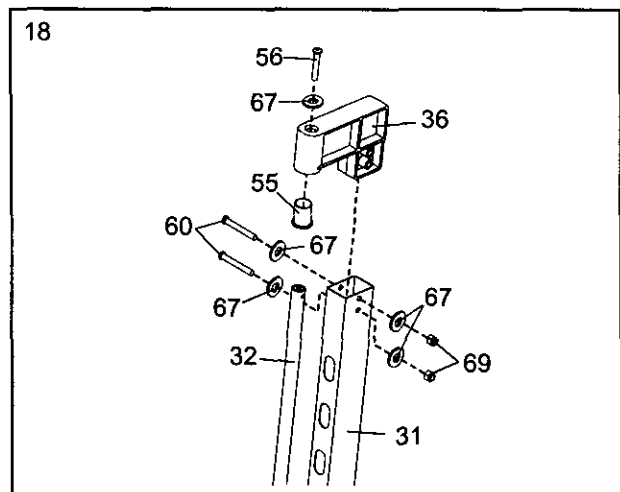

19. Slide the Weight Bar (33) through the Left Barbell Glider (37), the Locking Bar (34), and the Right Barbell Glider (81). **Make sure the Locking Bar is oriented as shown.**

Engage the hooks on the Locking Bar (34) into a set of holes in the Uprights (31, 62).

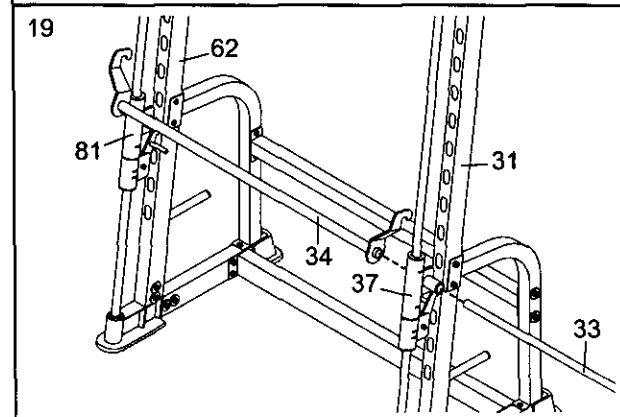

20. Slide a Weight Stop (42) onto the Weight Bar (33). Thread a 1/4" x 14mm Button Screw (59) into the Weight Stop and the hole in the Weight Bar. **Do not tighten the Screws yet.**

Thread a 1/4" x 14mm Button Screw (59) into the Left Barbell Glider (37).

Repeat this step with the Right Barbell Glider (not shown) and the other Weight Stop (not shown).

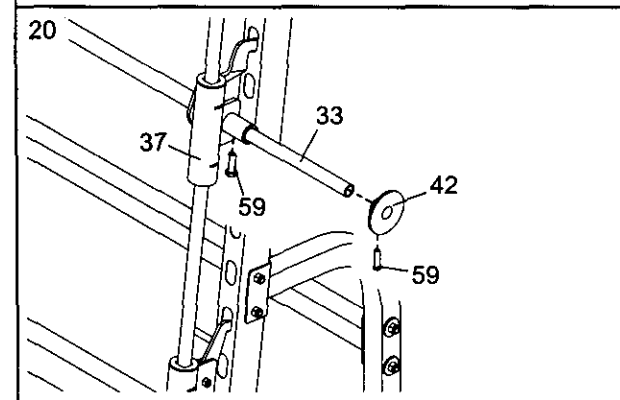

21. Press a 48mm Tapered Inner Cap (46) into a Barbell Adapter (41).

Slide a Barbell Adapter (41) onto the Weight Bar (33). Thread a 1/4" x 9.5mm Allen Head Set Screw (66) into the Barbell Adapter. **Do not tighten the Screw yet.**

Repeat this step with the other Barbell Adapter (not shown).

Tighten the M10 Nylon Locknuts (69) used in steps 11–21. Tighten the 1/4" x 14mm Button Screws (59) and 1/4" x 9.5mm Allen Head Set Screw (66) used in steps 20 and 21.

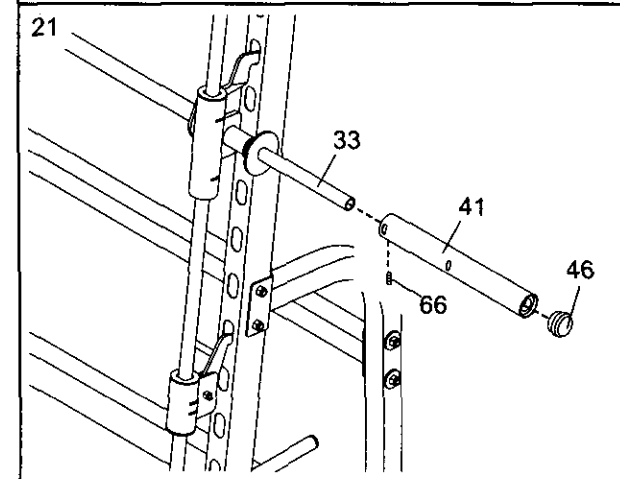

ADJUSTMENTS

This section explains how to adjust the weight bench. See the EXERCISE GUIDELINES on page 15 for important information about how to get the most benefit from your exercise program. Also, refer to the accompanying exercise guide to see the correct form for each exercise.

Make sure all parts are properly tightened each time the weight bench is used. Replace any worn parts immediately. The weight bench can be cleaned with a damp cloth and a mild, non-abrasive detergent. Do not use solvents.

ADJUSTING THE BACKREST

To adjust the position of the Backrest (12), hold the upper end of the Backrest with one hand and lift the Adjustment Lever (8) with the other hand, disengaging the Backrest Bracket (10). Raise or lower the Backrest to the desired position. Lower the Adjustment Lever so that the M10 x 65mm Flat Head Screw (77 [not shown]) engages one of the notches in the Backrest Bracket.

⚠WARNING: Always hold the Backrest (12) securely before disengaging the Backrest Bracket (10). Always make sure the Backrest Bracket is fully engaged before using the Backrest.

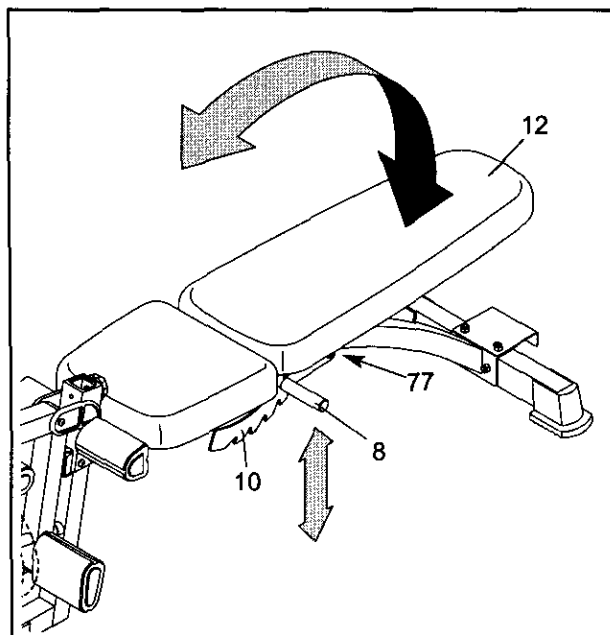

ATTACHING THE CURL POST

For some exercises, the Curl Post (5) must be attached to the weight bench. Slide the Curl Post into the Leg Lever Bracket (7). Align the adjustment holes in the Curl Post with the adjustment hole in the Leg Lever Bracket. Tighten the Curl Knob (22) into the adjustment hole in the Leg Lever Bracket. **Fully tighten the Knob.**

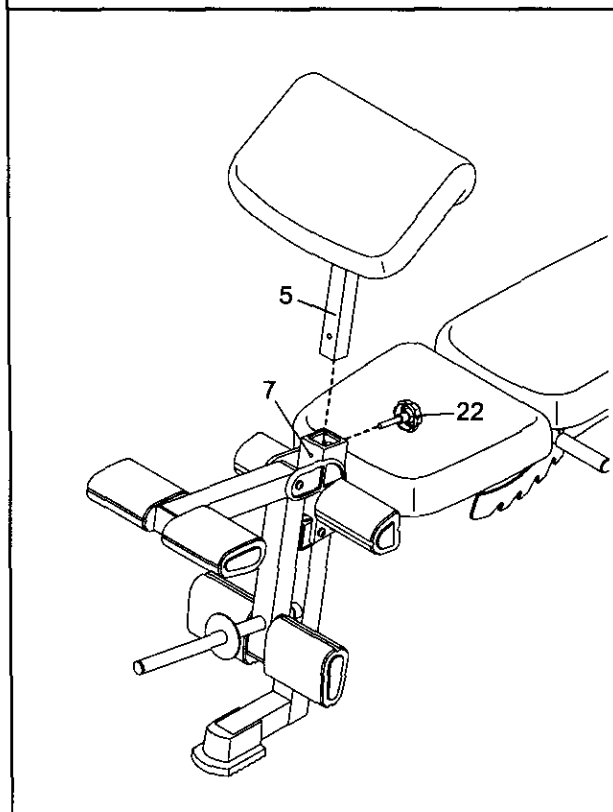

USING THE BENCH FOR PRESS EXERCISES

To prevent the weight rack from tipping while performing press exercises on the bench, set the "L"-bracket (76) over the Center Base (27).

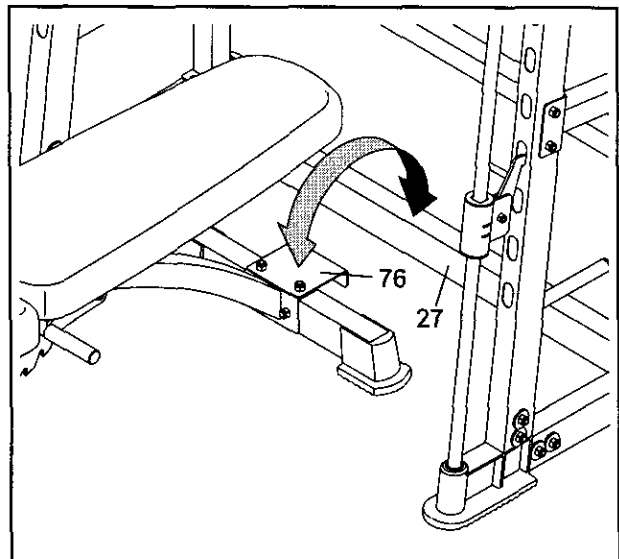

USING THE OLYMPIC WEIGHT ADAPTER

Press a 48mm Round Inner Cap (16) into the Olympic Adapter (15). Attach the Olympic Adapter to the Weight Tube (11) with a 1/4" x 9.5mm Allen Head Set Screw (66). **Make sure that the Set Screw is in the bottom of the Adapter.**

Press a 48mm Round Inner Cap (16) into a Weight Adapter (49). Attach the Weight Adapter to the Curl Bar (47) with a 1/4" x 9.5mm Allen Head Set Screw (66). **Make sure that the Set Screw is in the bottom of the Adapter.** Attach the other Weight Adapter to the Curl Bar in the same manner.

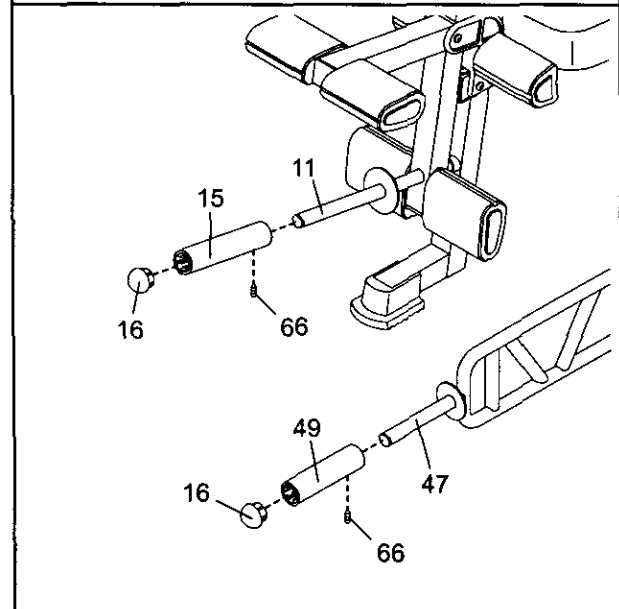

ATTACHING WEIGHTS TO THE LEG LEVER

To use the Leg Lever (4), slide the desired weights (not included) onto the Weight Tube (11). Secure the weights with a Weight Clip (83 or 84 [not shown]).

Weights can be added to the Curl Bar (not shown) in the same manner. Secure the weights to the Curl Bar with two Weight Clips (83 or 84 [not shown]).

⚠ WARNING: Do not place more than 150 pounds on the Weight Tube (11) or the Curl Bar (47).

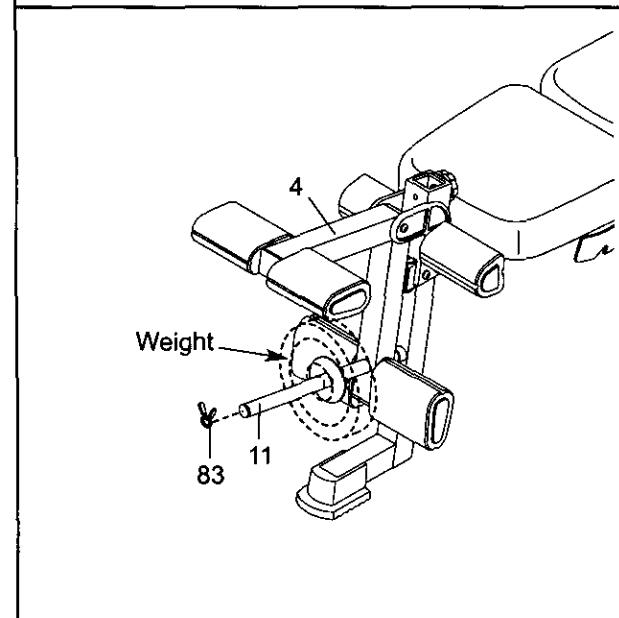

ATTACHING WEIGHTS TO THE BARBELL OR THE WEIGHT CARRIAGE

To use the barbell, slide the desired amount of weight (not included) onto the Barbell Adapters (41). Secure the weights with the Large Weight Clips (84).

▲ WARNING: Do not place more than 310 pounds on the barbell. Always place the same amount of weight on each side of the barbell. Always secure weights with the Large Weight Clips (84).

Your weights can be stored on the tubes on the Uprights (31 [not shown], 62) (see the inset drawing).

USING THE LOCKING BAR

Before starting an exercise, position the Locking Bar (34) and the Safety Spotters (not shown) in the correct position for the exercise.

To do this, stand in front of the rack and grip the Locking Bar (34) with both hands. Turn the Locking Bar until the two hooks disengage the slots in the Uprights (31, 62 [not shown]). Raise or lower the Locking Bar to a new position and turn it until the hooks engage the slots in the Uprights.

USING THE SAFETY SPOTTERS

To move the Safety Spotters (38) to a new position, grip the handles on the Spotter Hooks (39, 40 [not shown]) and pull the hooks out of the slots in the Uprights (31 [not shown], 62). Raise or lower the Safety Spotters to new positions and pivot the hooks back into the slots in the Uprights. **Note: Always position the Safety Spotters at the lowest point to which you want the barbell to move during the exercise.**

▲ WARNING: Always set both Safety Spotters (38) at the same height.

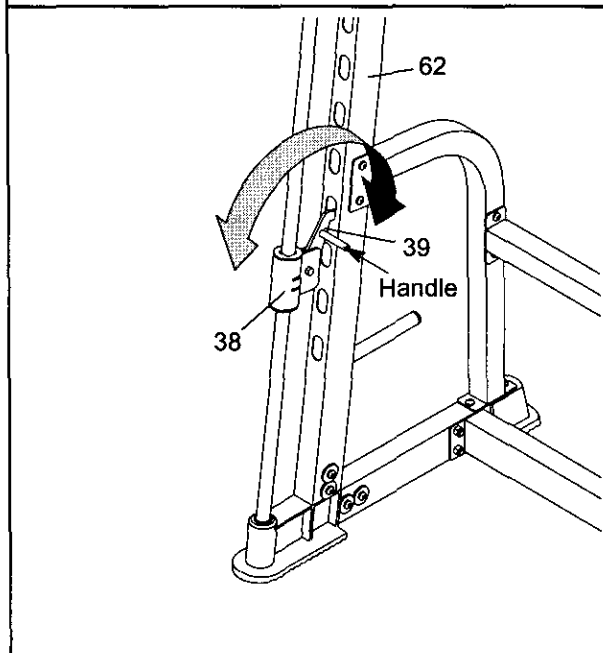
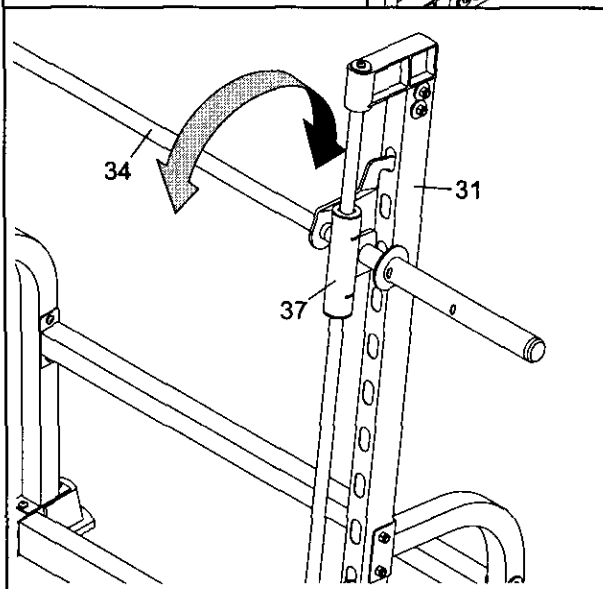
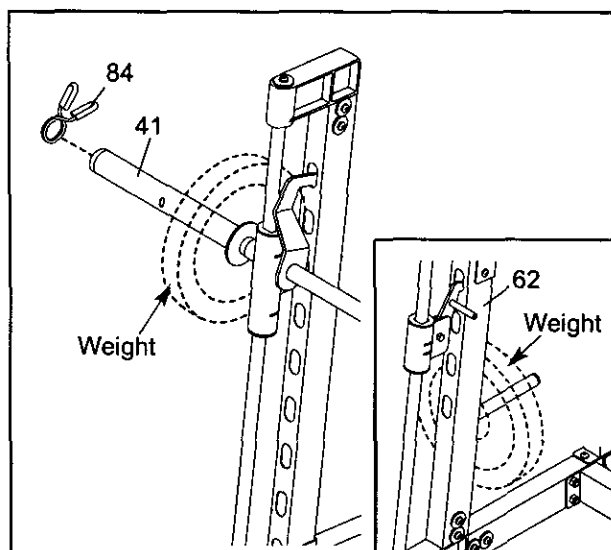

EXERCISE GUIDELINES

THE FOUR BASIC TYPES OF WORKOUTS

MUSCLE BUILDING

To increase the size and strength of your muscles, push them close to their maximum capacity. Your muscles will continually adapt and grow as you progressively increase the intensity of your exercise. You can adjust the intensity level of an individual exercise in two ways:

- by changing the amount of resistance used
- by changing the number of repetitions or sets performed. (A "repetition" is one complete cycle of an exercise, such as one sit-up. A "set" is a series of repetitions.)

The proper amount of resistance for each exercise depends upon the individual user. You must gauge your limits and select the amount of resistance that is right for you. Begin with 3 sets of 8 repetitions for each exercise you perform. Rest for 3 minutes after each set. When you can complete 3 sets of 12 repetitions without difficulty, increase the amount of resistance.

TONING

You can tone your muscles by pushing them to a moderate percentage of their capacity. Select a moderate amount of resistance and increase the number of repetitions in each set. Complete as many sets of 15 to 20 repetitions as possible without discomfort. Rest for 1 minute after each set. Work your muscles by completing more sets rather than by using high amounts of resistance.

WEIGHT LOSS

To lose weight, use a low amount of resistance and increase the number of repetitions in each set. Exercise for 20 to 30 minutes, resting for a maximum of 30 seconds between sets.

CROSS TRAINING

Cross training is an efficient way to get a complete and well-balanced fitness program. An example of a balanced program is:

- Plan strength training workouts on Monday, Wednesday, and Friday.
- Plan 20 to 30 minutes of aerobic exercise, such as running on a treadmill or riding on an elliptical or exercise bike, on Tuesday and Thursday.
- Rest from both strength training and aerobic exercise for at least one full day each week to give your body time to regenerate.

The combination of strength training and aerobic exercise will reshape and strengthen your body, plus develop your heart and lungs.

PERSONALIZING YOUR EXERCISE PROGRAM

Determining the exact length of time for each workout, as well as the number of repetitions or sets completed, is an individual matter. It is important to avoid overdoing it during the first few months of your exercise program. You should progress at your own pace and be sensitive to your body's signals. If you experience pain or dizziness at any time while exercising, stop immediately and begin cooling down. Find out what is wrong before continuing. Remember that adequate rest and a proper diet are important factors in any exercise program.

WARMING UP

Begin each workout with 5 to 10 minutes of stretching and light exercise to warm up. Warming up prepares your body for more strenuous exercise by increasing circulation, raising your body temperature and delivering more oxygen to your muscles.

WORKING OUT

Each workout should include 6 to 10 different exercises. Select exercises for every major muscle group, emphasizing areas that you want to develop most. To give balance and variety to your workouts, vary the exercises from session to session.

Schedule your workouts for the time of day when your energy level is the highest. Each workout should be followed by at least one day of rest. Once you find the schedule that is right for you, stick with it.

EXERCISE FORM

Maintaining proper form is an essential part of an effective exercise program. This requires moving through the full range of motion for each exercise, and moving only the appropriate parts of the body. Exercising in an uncontrolled manner will leave you feeling exhausted. On the exercise guide accompanying this manual you will find photographs showing the correct form for several exercises, and a list of the muscles affected. Refer to the muscle chart on the next page to find the names of the muscles.

The repetitions in each set should be performed smoothly and without pausing. The exertion stage of each repetition should last about half as long as the return stage. Proper breathing is important. Exhale during the exertion stage of each repetition and inhale during the return stroke. Never hold your breath.

Rest for a short period of time after each set. The ideal resting periods are:

- Rest for three minutes after each set for a muscle building workout.
- Rest for one minute after each set for a toning workout.
- Rest for 30 seconds after each set for a weight loss workout.

Plan to spend the first couple of weeks familiarizing yourself with the equipment and learning the proper form for each exercise.

COOLING DOWN

End each workout with 5 to 10 minutes of stretching. Include stretches for both your arms and legs. Move

slowly as you stretch and do not bounce. Ease into each stretch gradually and go only as far as you can without strain. Stretching at the end of each workout is an effective way to increase flexibility.

STAYING MOTIVATED

For motivation, keep a record of each workout. The chart on pages 17–19 of this manual can be photocopied and used to schedule and record your workouts. List the date, the exercises performed, the resistance used, and the numbers of sets and repetitions completed. Record your weight and key body measurements at the end of every month. Remember, the key to achieving the greatest results is to make exercise a regular and enjoyable part of your everyday life.

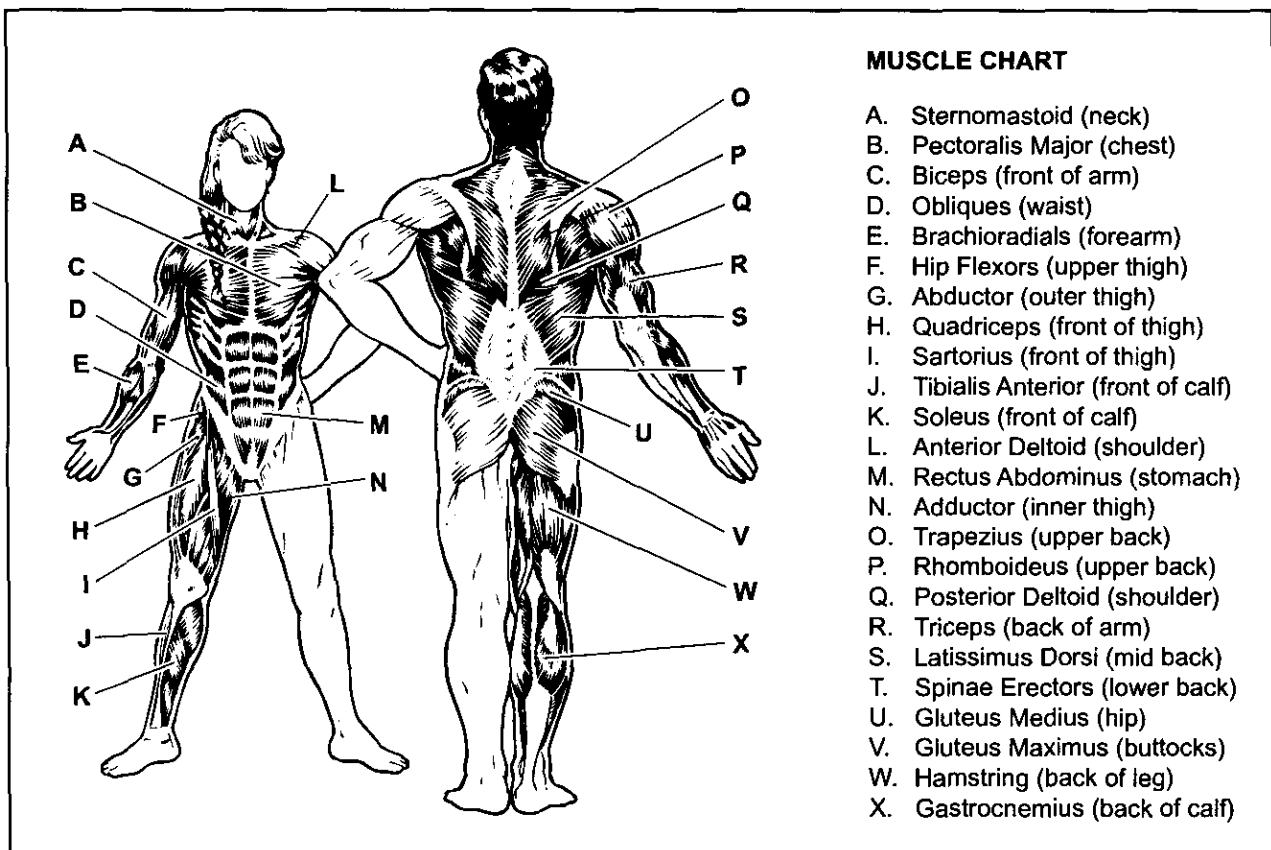

MONDAY Date: _____ / ____ / ____	EXERCISE	WEIGHT	SETS	REPS

TUESDAY AEROBIC EXERCISE

Date: _____ / ____ / ____

WEDNESDAY Date: _____ / ____ / ____	EXERCISE	WEIGHT	SETS	REPS

THURSDAY AEROBIC EXERCISE

Date: _____ / ____ / ____

FRIDAY Date: _____ / ____ / ____	EXERCISE	WEIGHT	SETS	REPS

Make photocopies of this page for scheduling and recording your workouts.

MONDAY Date: _____ / ____ / ____	EXERCISE	WEIGHT	SETS	REPS

TUESDAY AEROBIC EXERCISE

Date: _____ / ____ / ____

WEDNESDAY Date: _____ / ____ / ____	EXERCISE	WEIGHT	SETS	REPS

THURSDAY AEROBIC EXERCISE

Date: _____ / ____ / ____

FRIDAY Date: _____ / ____ / ____	EXERCISE	WEIGHT	SETS	REPS

Make photocopies of this page for scheduling and recording your workouts.

MONDAY Date: _____ / ____ / ____	EXERCISE	WEIGHT	SETS	REPS

TUESDAY AEROBIC EXERCISE

Date: _____ / ____ / ____

WEDNESDAY Date: _____ / ____ / ____	EXERCISE	WEIGHT	SETS	REPS

THURSDAY AEROBIC EXERCISE

Date: _____ / ____ / ____

FRIDAY Date: _____ / ____ / ____	EXERCISE	WEIGHT	SETS	REPS

Make photocopies of this page for scheduling and recording your workouts.

PART LIST—Model No. 831.150330

R0803A

Key No.	Qty.	Description	Key No.	Qty.	Description
1	1	Bench Frame	47	1	Curl Bar
2	1	Stabilizer	48	4	M10 x 93mm Button Bolt
3	1	Bench Leg	49	2	Weight Adapter
4	1	Leg Lever	50	2	Pad Tube
5	1	Curl Post	51	4	Large Foam Pad
6	2	Backrest Tube	52	2	Small Foam Pad
7	1	Leg Lever Bracket	53	4	Large Pad Cap
8	1	Adjustment Lever	54	2	Small Pad Cap
9	4	Base Cap	55	2	Top Bracket Bushing
10	1	Backrest Bracket	56	4	M10 x 30mm Button Screw
11	1	Weight Tube	57	2	M8 x 12mm Shoulder Bolt
12	1	Backrest	58	5	M4 x 16mm Screw
13	1	Seat	59	4	1/4" x 14mm Button Screw
14	1	Curl Pad	60	12	M10 x 65mm Button Bolt
15	1	Olympic Adapter	61	2	M10 x 95mm Carriage Bolt
16	3	48mm Round Inner Cap	62	1	Right Upright
17	2	50mm Square Inner Cap	63	4	M6 x 16mm Screw
18	1	Notched Square Inner Cap	64	4	M6 x 38mm Screw
19	4	25mm Square Inner Cap	65	1	M6 x 63mm Screw
20	5	25mm Round Inner Cap	66	5	1/4" x 9.5mm Allen Head Set Screw
21	1	Handgrip			
22	1	Curl Knob	67	50	M10 Washer
23	2	Small Round Bushing	68	5	M6 Washer
24	1	25mm Round Angled Cap	69	41	M10 Nylon Locknut
25	1	13mm Spacer	70	1	M10 x 73mm Button Bolt
26	2	M10 Nylon Jamnut	71	1	M8 x 63mm Button Bolt
27	1	Center Base	72	3	M8 Nylon Locknut
28	2	Base	73	2	M8 Washer
29	2	Rear Support	74	4	M10 x 45mm Button Bolt
30	1	Crossbar	75	3	M10 x 81mm Button Bolt
31	1	Left Upright	76	1	"L"-bracket
32	2	Guide Bar	77	1	M10 x 65mm Flat Head Screw
33	1	Weight Bar	78	2	M10 x 25mm Button Screw
34	1	Locking Bar	79	18	M10 x 68mm Button Bolt
35	2	Rack Foot	80	1	Small Base Cap
36	2	Top Bracket	81	1	Right Barbell Glider
37	1	Left Barbell Glider	82	1	Long Pad Tube
38	2	Safety Spotter	83	2	Small Weight Clip
39	1	Right Spotter Hook	84	2	Large Weight Clip
40	1	Left Spotter Hook	85	1	M10 x 155mm Button Bolt
41	2	Barbell Adapter	86	1	Thin Notched Square Inner Cap
42	2	Weight Stop	#	1	User's Manual
43	8	Glider Bushing	#	1	Exercise Guide
44	4	Weight Bar Glider Bushing	#	1	Grease Pack
45	2	Round Angled Bushing	#	3	Allen Wrench
46	2	48mm Tapered Inner Cap			

Note: "#" indicates a non-illustrated part. Specifications are subject to change without notice. See the back cover of the user's manual for information about ordering replacement parts.

PART IDENTIFICATION CHART

This chart is provided to help you identify the small parts used in assembly. The number in parenthesis below each part refers to the key number of the part from the PART LIST in the center of this manual. **Important:** Some parts may have been pre-assembled for shipping purposes. If a part is not in the parts bag, check to see if it has been pre-attached. If a part is missing, call toll-free 1-800-999-3756.

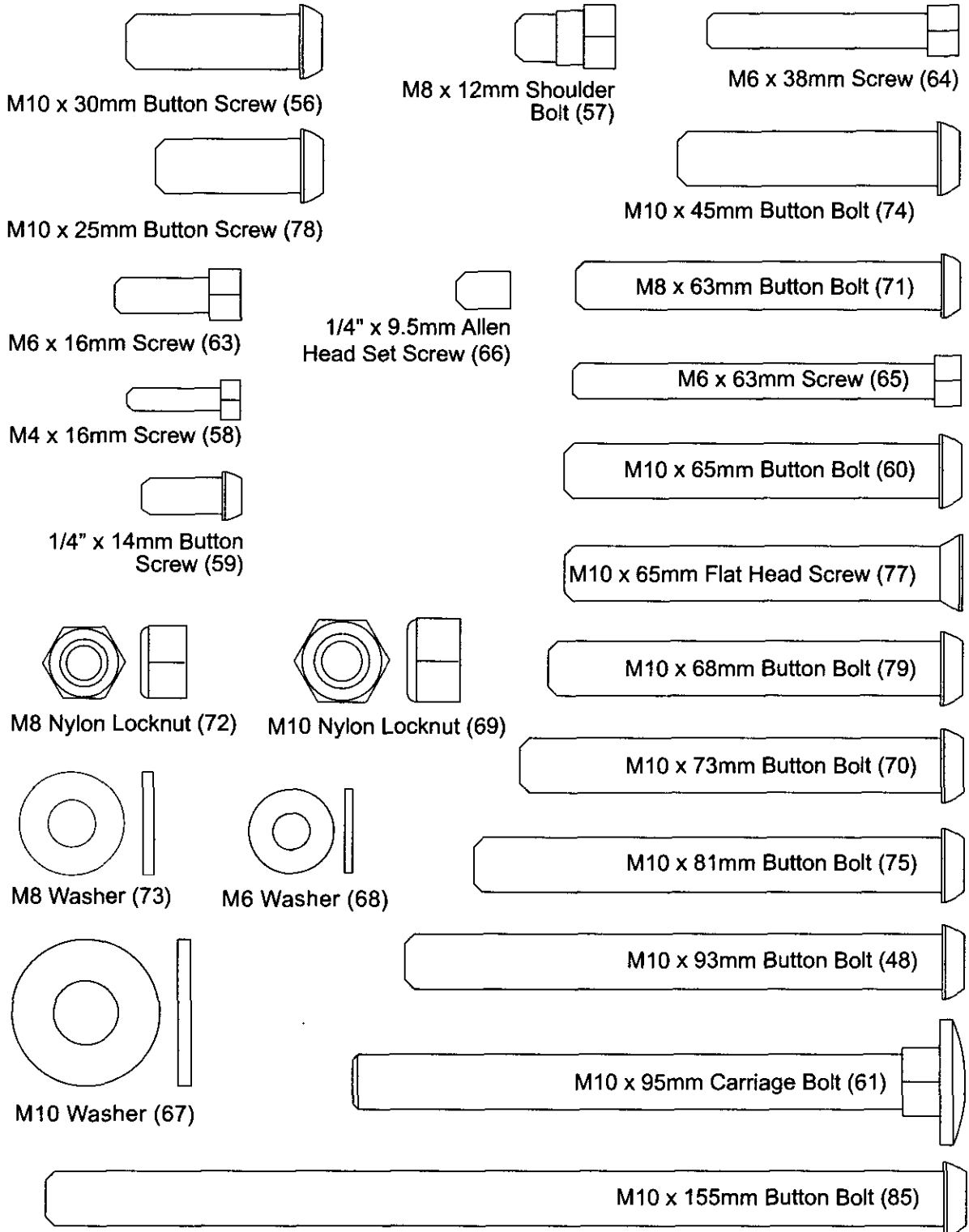

EXPLODED DRAWING—Model No. 831.150330

R0803A

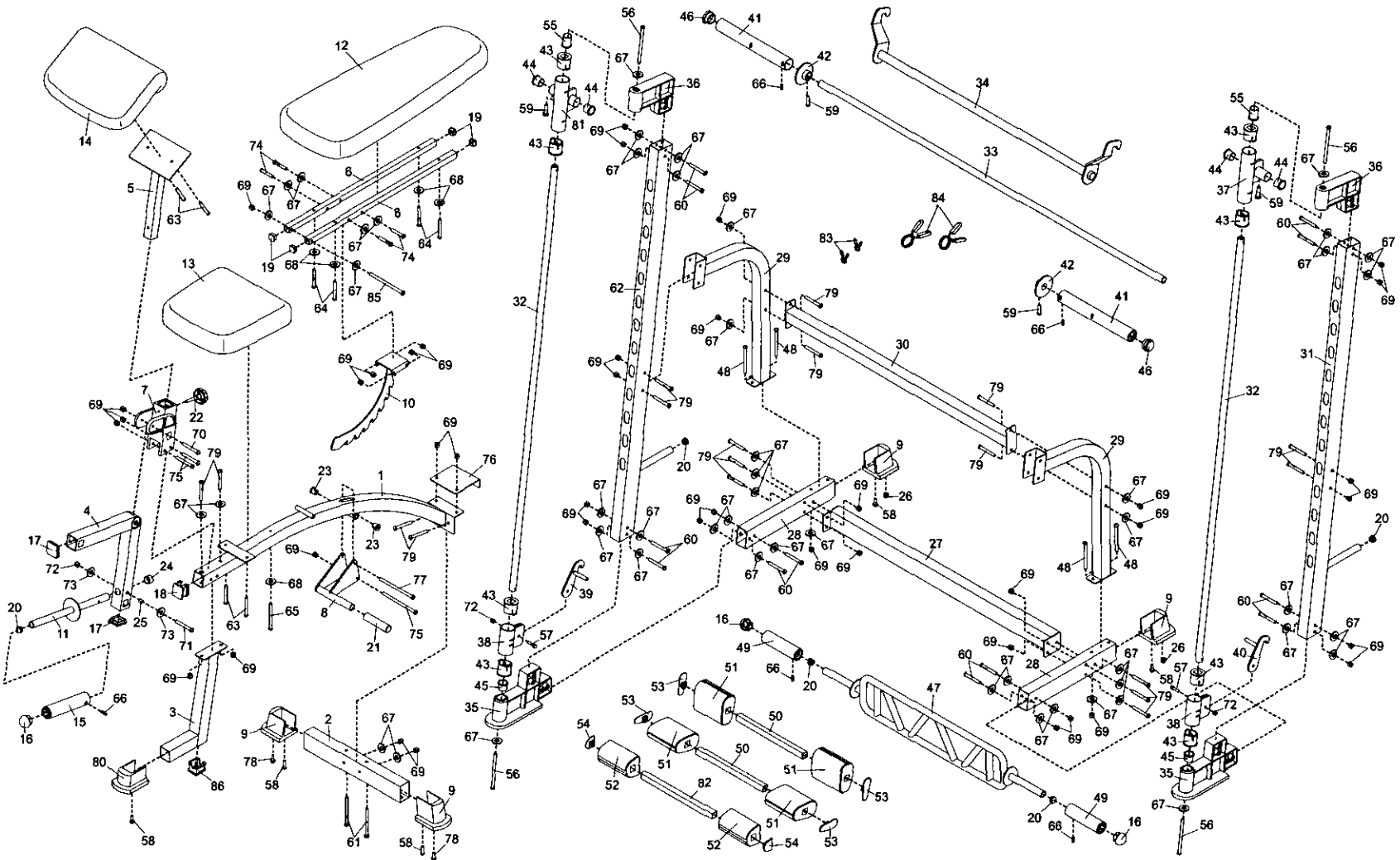

Get it fixed, at your home or ours!

Your Home

For repair – **in your home** – of **all** major brand appliances, lawn and garden equipment, or heating and cooling systems, **no matter who made it, no matter who sold it!**

For the replacement parts, accessories, and user's manuals that you need to do-it-yourself.

For Sears professional installation of home appliances and items like garage door openers and water heaters.

1-800-4-MY-HOME®

(1-800-469-4663)

www.sears.com

Anytime, day or night

(U.S.A. and Canada)

www.sears.ca

Our Home

For repair of carry-in products like vacuums, lawn equipment, and electronics, call or go on-line for the location of your nearest **Sears Parts and Repair Center.**

1-800-488-1222 Anytime, day or night (U.S.A. only)

www.sears.com

To purchase a protection agreement (U.S.A.) or maintenance agreement (Canada) on a product serviced by Sears:

1-800-827-6655 (U.S.A.)

1-800-361-6665 (Canada)

Para pedir servicio de reparación a domicilio, y para ordenar piezas:

1-888-SU-HOGARSM (1-888-784-6427)

SEARS

® Registered Trademark / TM Trademark / SM Service Mark of Sears, Roebuck and Co.
© Marca Registrada / TM Marca de Fábrica / SM Marca de Servicio de Sears, Roebuck and Co.

FULL 90-DAY WARRANTY

For 90 days from the date of purchase, if failure occurs due to defect in material or workmanship in this **WEIGHT BENCH EXERCISER**, contact the nearest Sears Service Center throughout the United States and Sears will repair or replace the **WEIGHT BENCH EXERCISER**, free of charge.

This warranty does not apply when the **WEIGHT BENCH EXERCISER** is used commercially or for rental purposes.

This warranty gives you specific legal rights, and you may also have other rights which vary from state to state.

Sears, Roebuck and Co., Dept 817WA, Hoffman Estates, IL 60179