

# PRO-FORM<sup>®</sup>

# C740

Model No. 831.150320

Serial No. \_\_\_\_\_

Write the serial number in the space above for reference.

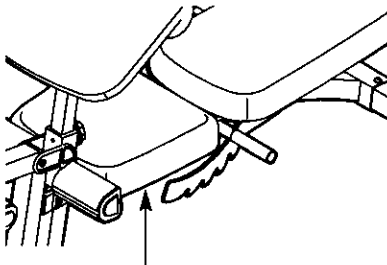

Serial Number Decal (under seat)

## WEIGHT BENCH EXERCISER User's Manual

- Assembly
- Adjustments
- Part List and Drawing

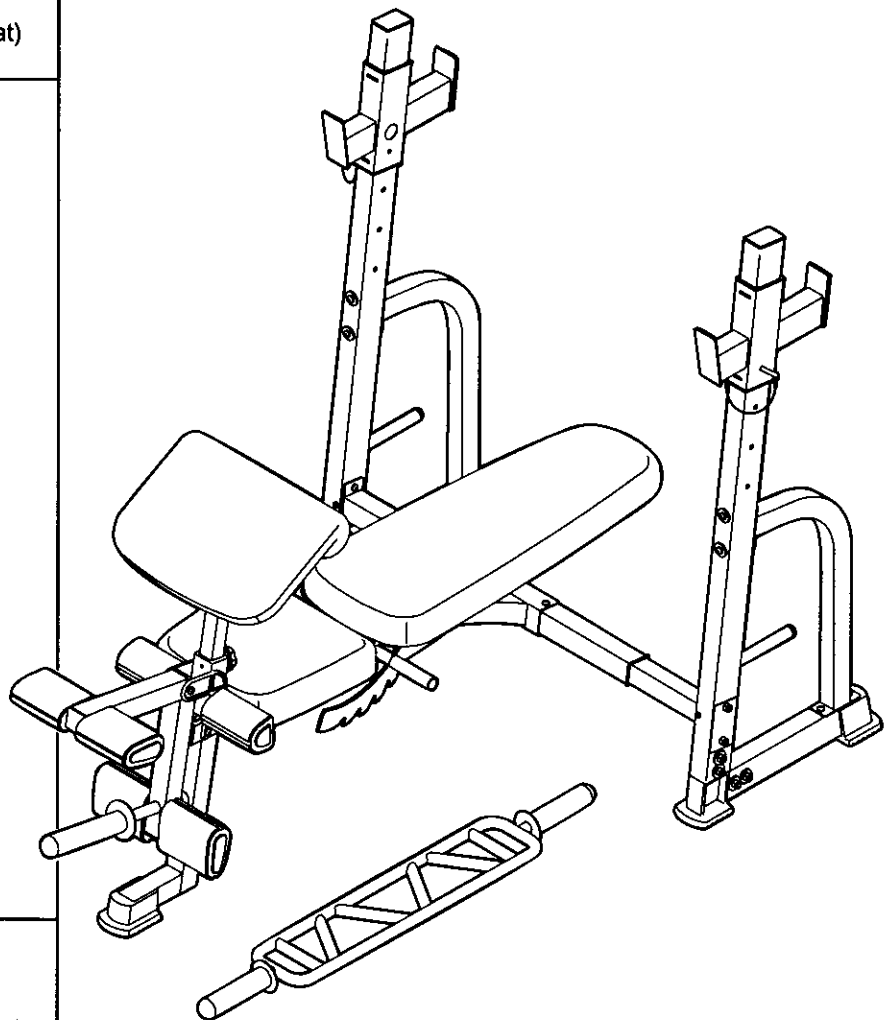

### **▲ CAUTION**

Read all precautions and instructions in this manual before using this equipment. Save this manual for future reference.

Sears, Roebuck and Co., Hoffman Estates, IL 60179

# TABLE OF CONTENTS

|                                  |            |
|----------------------------------|------------|
| WARNING DECAL PLACEMENT .....    | 2          |
| IMPORTANT PRECAUTIONS .....      | 3          |
| BEFORE YOU BEGIN .....           | 4          |
| ASSEMBLY .....                   | 5          |
| ADJUSTMENTS .....                | 11         |
| EXERCISE GUIDELINES .....        | 13         |
| ORDERING REPLACEMENT PARTS ..... | Back Cover |
| FULL 90-DAY WARRANTY .....       | Back Cover |

Note: A PART IDENTIFICATION CHART and a PART LIST/EXPLODED DRAWING is attached in the center of this manual. Remove the PART IDENTIFICATION CHART and PART LIST/EXPLODED DRAWING before beginning assembly.

## WARNING DECAL PLACEMENT

The warning decal shown here has been placed on the weight bench in the location shown. If the decal is missing or illegible, please call toll-free 1-800-999-3756, Monday through Friday, 6 a.m. until 6 p.m. Mountain Time, to order a free replacement decal. Place the decal on the weight bench in the location shown.

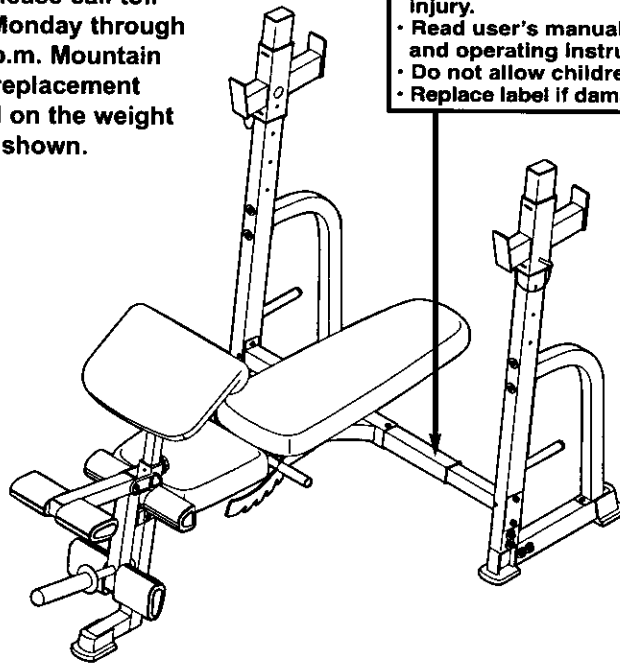
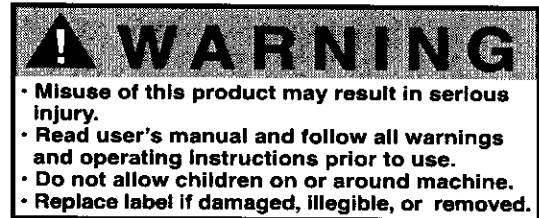

# IMPORTANT PRECAUTIONS

**▲ WARNING:** To reduce the risk of serious injury, read the following important precautions before using the weight bench.

1. Read all instructions in this manual before using the weight bench. Use the weight bench only as described in this manual.
2. It is the responsibility of the owner to ensure that all users of the weight bench are adequately informed of all precautions.
3. The weight bench is intended for home use only. Do not use the weight bench in any commercial, rental, or institutional setting.
4. Use the weight bench only on a level surface. Cover the floor beneath the weight bench to protect the floor.
5. Make sure that all parts are properly tightened each time the weight bench is used. Replace any worn parts immediately.
6. make sure that the set screws attaching the Olympic adapters are properly tightened each time the adapters are used.
7. Keep children under 12 and pets away from the weight bench at all times.
8. Always wear athletic shoes for foot protection while exercising.
9. Keep hands and feet away from moving parts.
10. The weight bench is designed to support a maximum user weight of 300 pounds, and a maximum total weight of 610 pounds. Do not place more than 310 pounds, including a barbell and weights, on the weight rests. Do not place more than 150 pounds on the leg lever or curl bar. Note: The weight bench does not include a barbell or weights.
11. Use the curl bar only with the weight clips provided with the bench.
12. Do not use a barbell that is longer than six feet with the weight bench.
13. Always be sure there is an equal amount of weight on each side of your barbell when you are using it. Always keep some weight on both ends of the barbell when adding or removing weights to prevent the barbell from tipping.
14. When you are using the leg lever, place a barbell with the same amount of weight on the weight rests to balance the bench.
15. Always exercise with a partner. When you are performing bench press exercises, your partner should stand behind you to catch the barbell if you cannot complete a repetition.
16. Make sure that the adjustment knobs are inserted completely and tightened into the uprights before beginning any exercise.
17. Always make sure the backrest bracket is fully engaged before using the backrest.
18. When you put weight on the weight rests, make sure you put at least ten pounds on the leg lever to balance the weight bench.
19. Always remove the curl post from the front leg before performing leg curls with the leg lever.
20. If you feel pain or dizziness at any time while exercising, stop immediately and begin cooling down.

**▲ WARNING:** Before beginning this or any exercise program, consult your physician. This is especially important for persons over the age of 35 or persons with pre-existing health problems. Read all instructions before using. Sears assumes no responsibility for personal injury or property damage sustained by or through the use of this product.

# BEFORE YOU BEGIN

Thank you for selecting the versatile PROFORM® C740 weight bench. The weight bench offers an impressive array of weight stations designed to develop every major muscle group of the body. Whether your goal is to tone your body, build dramatic muscle size and strength, or improve your cardiovascular system, the weight bench will help you to achieve the specific results you want.

**For your benefit, read this manual carefully before using the weight bench.** If you have questions after

reading this manual, call 1-800-4-MY-HOME® (1-800-469-4663). To help us assist you, please note the product model number and serial number before calling. The model number is 831.150310. The serial number can be found on a decal attached to the weight bench (see the front cover of this manual for the location of the decal).

Before reading further, please review the drawing below and familiarize yourself with the parts that are labeled.

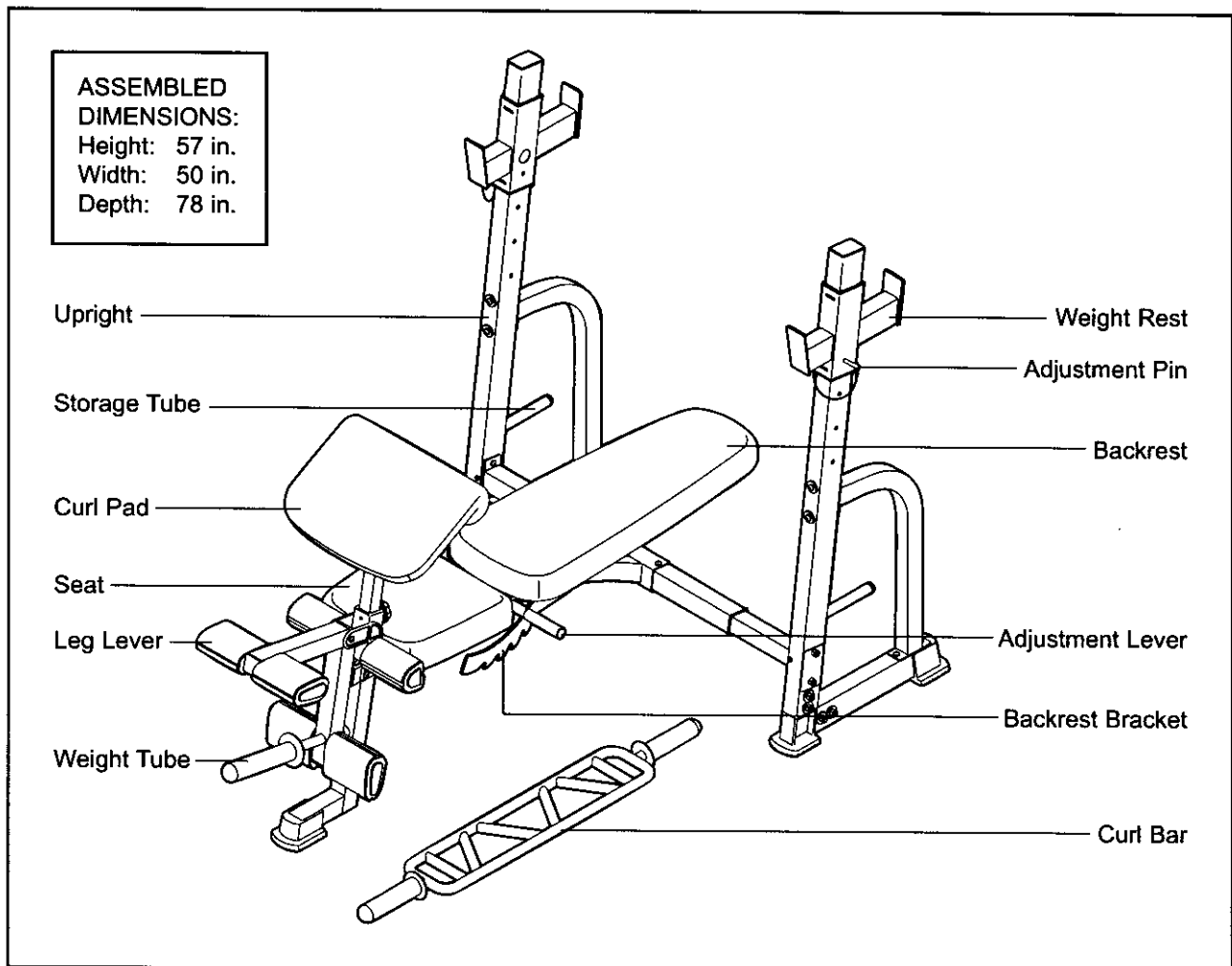

# ASSEMBLY

## Make Things Easier for Yourself



Everything in this manual is designed to ensure that the weight bench can be assembled successfully by anyone. However, it is important to realize that the versatile weight bench has many parts and that the assembly process will take time. Most people find that by setting aside plenty of time, assembly will go smoothly.

Before beginning assembly, carefully read the following information and instructions:

- Assembly requires two persons.
- Place all parts in a cleared area and remove the packing materials. Do not dispose of the packing materials until assembly is completed.
- Tighten all parts as you assemble them, unless instructed to do otherwise.

- As you assemble the weight bench, make sure all parts are oriented as shown in the drawings.
- For help identifying small parts, use the **PART IDENTIFICATION CHART**.

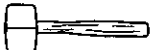
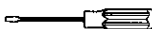
The following tools (not included) are required for assembly:

- Two adjustable wrenches 
- One rubber mallet 
- One standard screwdriver 
- One Phillips screwdriver 
- Lubricant, such as grease or petroleum jelly, and soapy water.

Assembly will be more convenient if you have a socket set, a set of open-end or closed-end wrenches, or a set of ratchet wrenches.

1. Before beginning assembly, make sure that you understand the information in the box above. For help identifying small parts, use the **PART IDENTIFICATION CHART**.

Attach a Base Foot (32) to a Stabilizer (6) with an M4 x 16mm Screw (52).

Attach a Support (7) to the Stabilizer (6) with two M10 x 93mm Button Bolts (45), an M10 Washer (53), an M10 Nylon Locknut (56), and an M10 Nylon Jamnut (69).

Attach an Upright Foot (33) to a Stabilizer (6) with two M10 x 68mm Button Bolts (64), four M10 Washers (53), and two M10 Nylon Locknuts (56). Make sure that the Bolts are inserted from the right side. Do not tighten the Locknuts yet.

Repeat this step with the other Stabilizer (6) and Support (7). Make sure that the M10 x 68mm Button Bolts (64) are inserted from the left side.

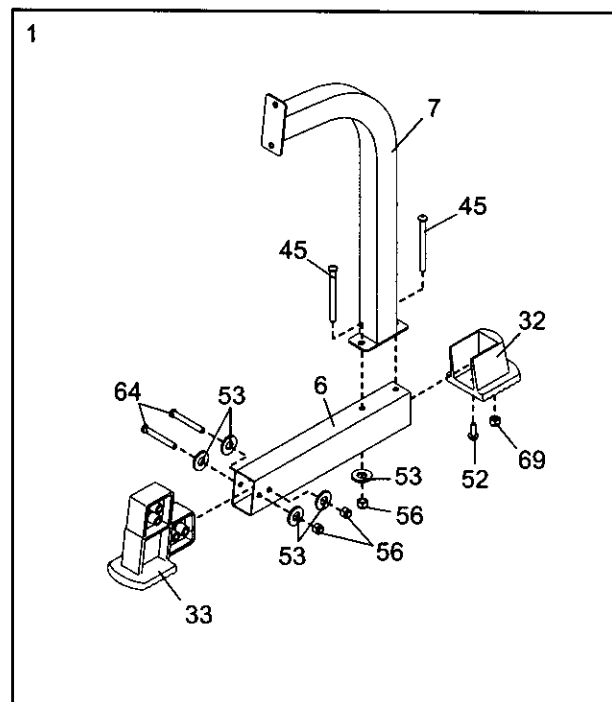

2. Locate the Left Upright (68), which has a name decal in the indicated location. Press a 25mm Round Inner Cap (20) into the Upright. Press a 2" x 3" Inner Cap (25) into the top of the Upright.

Attach the Left Upright (68) to the indicated Upright Foot (33) with two M10 x 68mm Button Bolts (64), four M10 Washers (53), and two M10 Nylon Locknuts (56). **Do not tighten the Locknuts yet. Make sure that the Locknuts are on the same side as the M10 Nylon Locknuts (56) on the Stabilizer (6).**

Attach the Left Upright (68) to the Support (7) with two M10 x 93mm Button Bolts (45), two M10 Washers (53), and two M10 Nylon Locknuts (56). **Do not tighten the Locknuts yet.**

**Repeat this step with the Right Upright (not shown).**

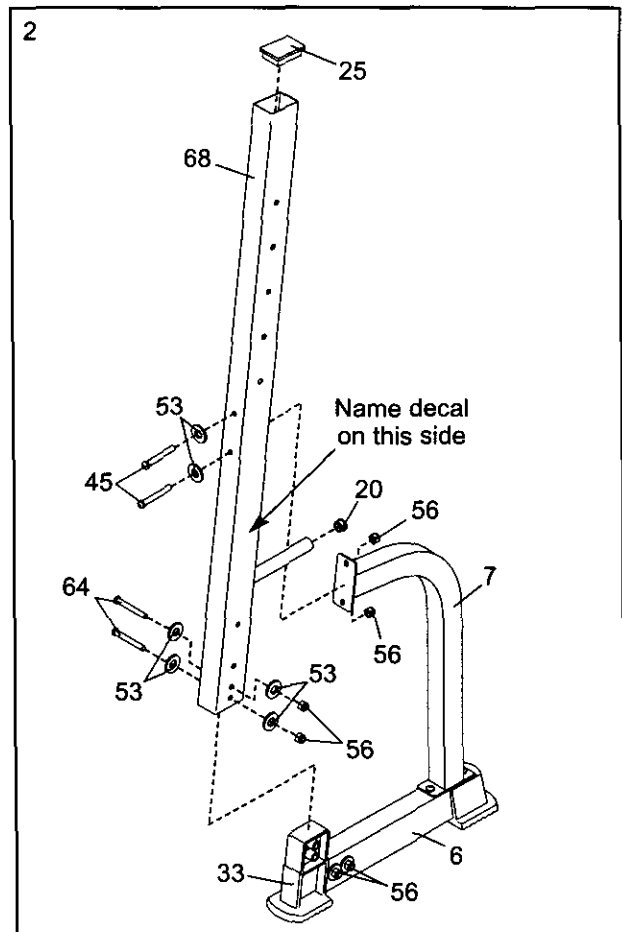

3. Attach the Inner Crossbar (4) to the Left Upright (68) with two M10 x 72mm Button Screws (44), a Support Plate (71), an M10 x 93mm Button Bolt (45), an M10 Washer (53), and three M10 Nylon Locknuts (56). **Do not tighten the Locknuts yet.**

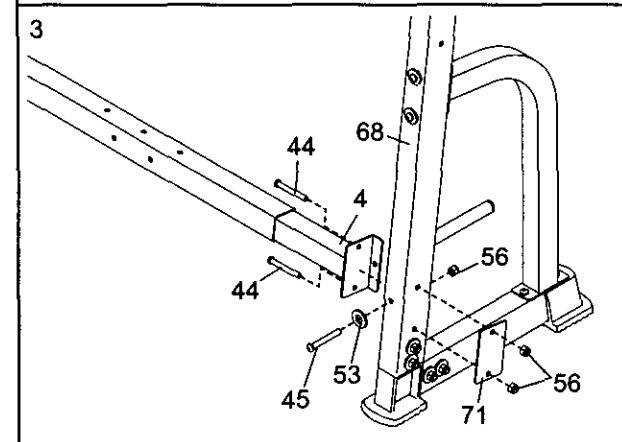

4. Attach the Crossbar (3) to the Right Upright (5) with two M10 x 72mm Button Screws (44), a Support Plate (71), an M10 x 93mm Button Bolt (45), an M10 Washer (53), and three M10 Nylon Locknuts (56). **Do not tighten the Locknuts yet.**

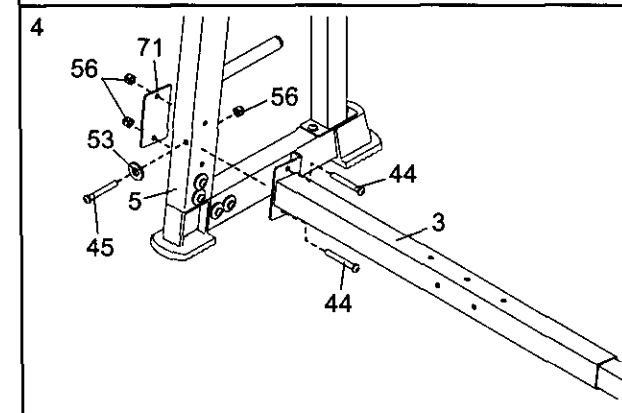

- Attach a Small Base Foot (70) to the Bench Base (2) with an M4 x 16mm Screw (52). Press a Notched Square Inner Cap (27) into the bottom of the Bench Base.

Press a Notched Square Inner Cap (27) into the Bench Frame (1).

Attach the Bench Base (2) to the Bench Frame (1) with two M10 x 68mm Button Bolt (64), two M10 Washers (53), and two M10 Nylon Locknuts (56). **Do not tighten the Locknuts yet.**

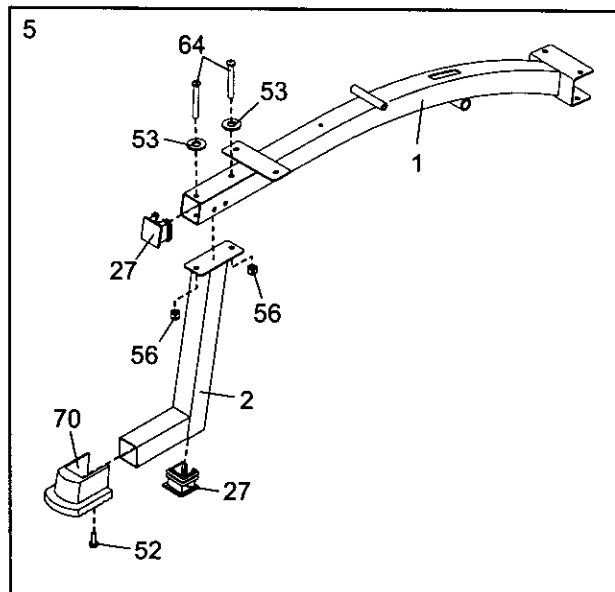

- Note: The weight bench can be adjusted to be used with either a mid-width barbell or an Olympic barbell. Refer to the inset drawing for correct hole alignment for each width.**

Align a set of holes in the Crossbar (3) and the Inner Crossbar (4). Attach the Bench Frame (1) to the Crossbars (3, 4) with an M10 x 72mm Button Screw (44), an M10 Washer (53), two M10 x 78mm Button Bolts (65), and two M10 Nylon Locknuts (56).

**Tighten the M10 Nylon Locknuts (56) and M10 Nylon Jamnuts (69) used in steps 1–6.**

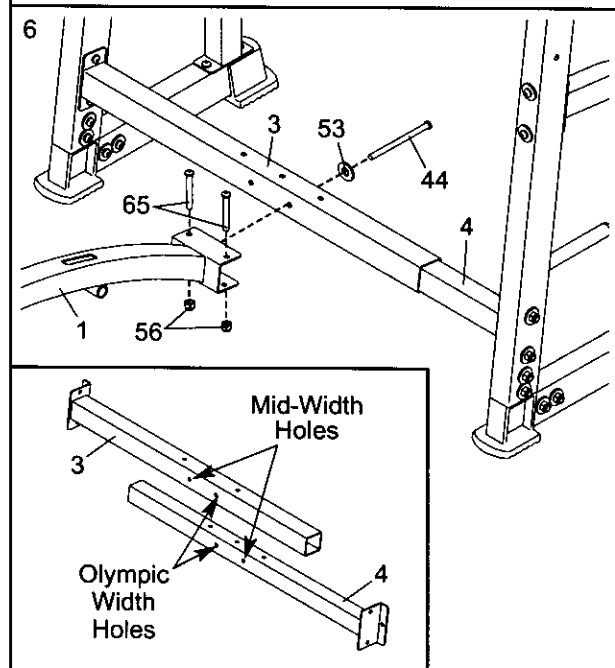

- Attach the Leg Station Attachment (14) to the Bench Frame (1) with two M10 x 81mm Hex Head Bolts (59) and two M10 Nylon Locknuts (56).

Press two 50mm Square Inner Caps (28) into the Leg Lever (8). Press a 25mm Round Inner Cap (20) into the Weight Tube (39).

Attach the Weight Tube (39) to the Leg Lever (8) with an M8 x 63mm Button Bolt (62), two M8 Washers (54), a 10mm Spacer (31), and an M8 Nylon Locknut (58). Press the 25mm Round Angled Cap (60) onto the Weight Tube.

Lubricate an M10 x 75mm Button Bolt (61) with grease. Attach the Leg Lever (8) to the Leg Station Attachment (14) with the Bolt and an M10 Nylon Locknut (56). **Do not overtighten the Locknut; the Leg Lever must be able to pivot easily.**

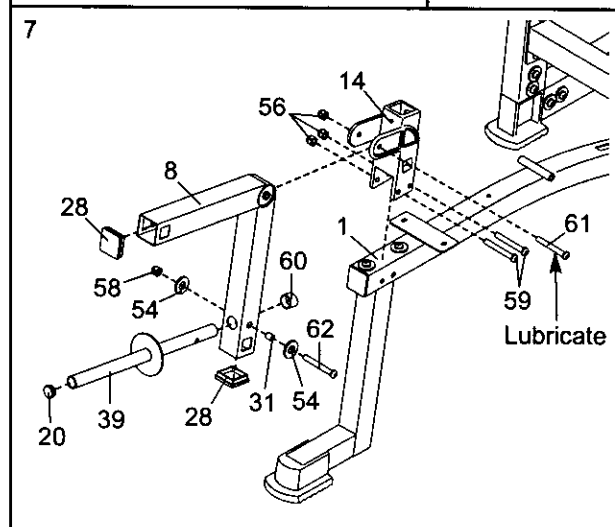

- Slide the Right Weight Rest (17) onto the Right Upright (5). Insert the Weight Rest Pin (43) into the Weight Rest and an adjustment hole in the Upright from the side shown. Rotate the Pin down so that it wraps around the back of the Upright.

**Repeat this step with the Left Weight Rest (not shown) and the Left Upright (not shown).**

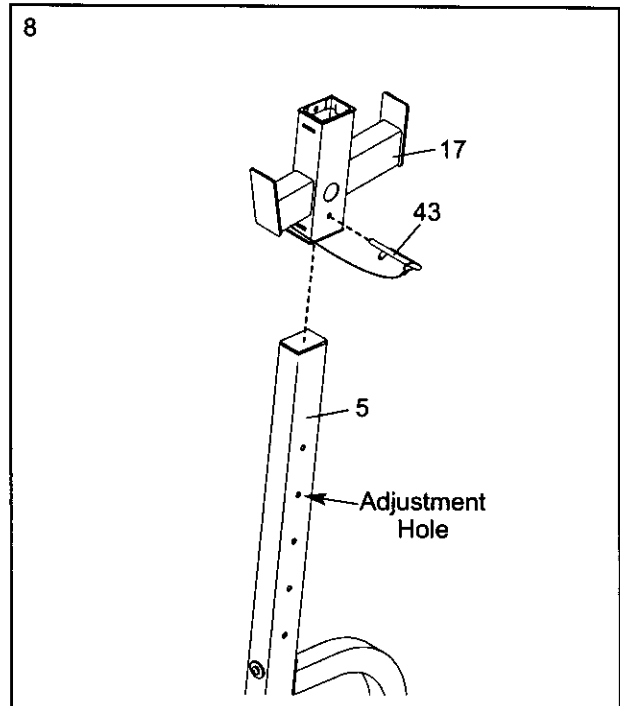

- Lubricate an M10 x 88mm Button Bolt (42) with grease. Attach the Adjustment Lever (29) to the tube on the bottom of the Bench Frame (1) with the Bolt and an M10 Nylon Locknut (56). **Do not overtighten the Locknut; the Lever must be able to pivot easily.**

Hold the handle on the Adjustment Lever (29) so that the upper hole is above the Bench Frame (1). Slide the M10 x 72mm Flat Head Screw (46) through the indicated side of the Lever, over the Bench Frame, and tighten it into the other side of the Adjustment Lever. **Make sure that the threads of the Screw show through the Adjustment Lever.**

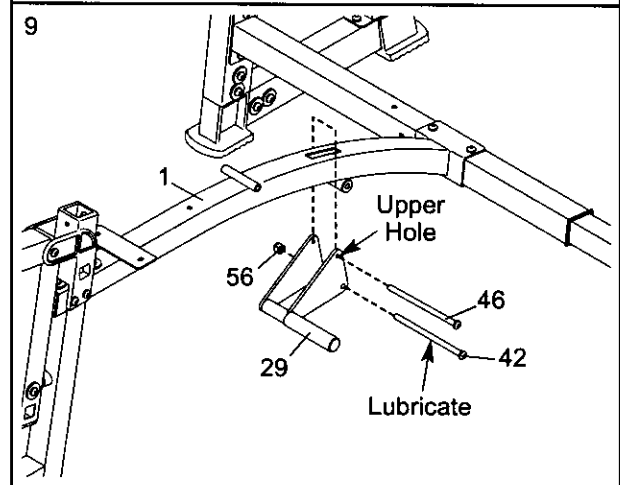

- Press four 25mm Square Inner Caps (26) into the Backrest Tubes (10).

Orient the Backrest Tubes (10) so that the indicated holes are closer to the bottom. Attach the Backrest Bracket (16) to the Backrest Tubes with four M10 x 43mm Button Bolts (49), four M10 Washers (53), and four M10 Nylon Locknuts (56). **Do not tighten the Locknuts yet.**

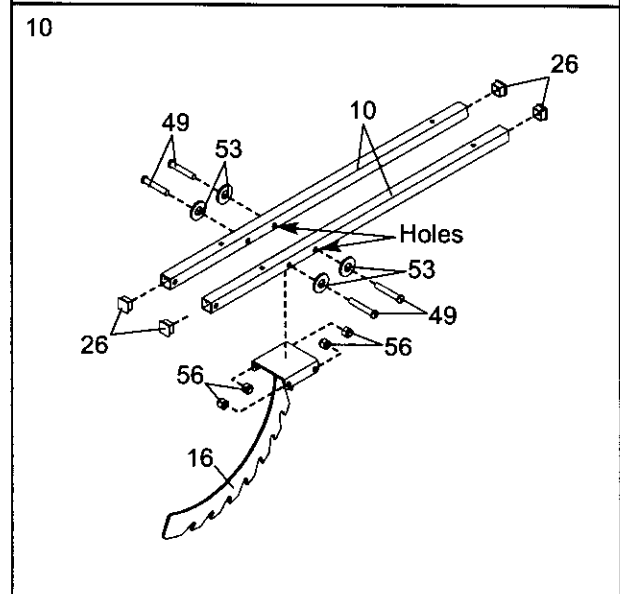



11. Insert the Backrest Bracket (16) through the slot in the Bench Frame (1) and under the Adjustment Lever (29). **Make sure that the M10 x 72mm Flat Head Screw (46) is under the Backrest Bracket arm.**

Lubricate an M10 x 155mm Button Bolt (57) with grease. Attach the Backrest Tubes (10) to the Bench Frame (1) with the Bolt, two M10 Washers (53), and an M10 Nylon Locknut (56). **Do not overtighten the Locknut; the backrest Tubes must be able to pivot easily.**

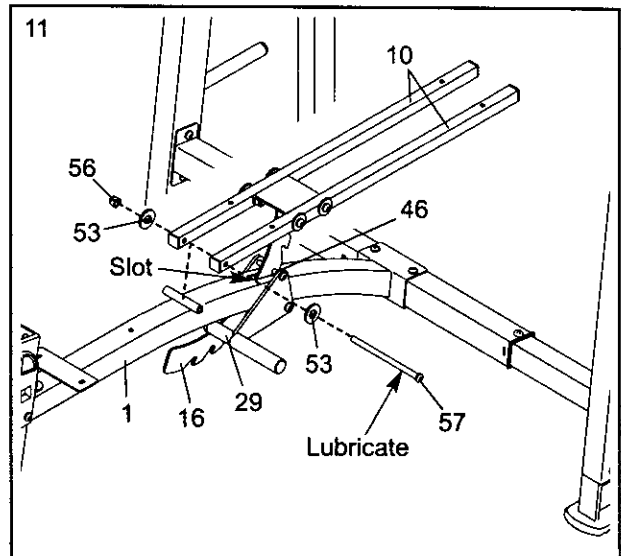

12. Attach the Backrest (12) to the Backrest Tubes (10) with four M6 x 38mm Screws (50) and four M6 Washers (55).

**Tighten the four M10 Nylon Locknuts (56) used in step 10.**

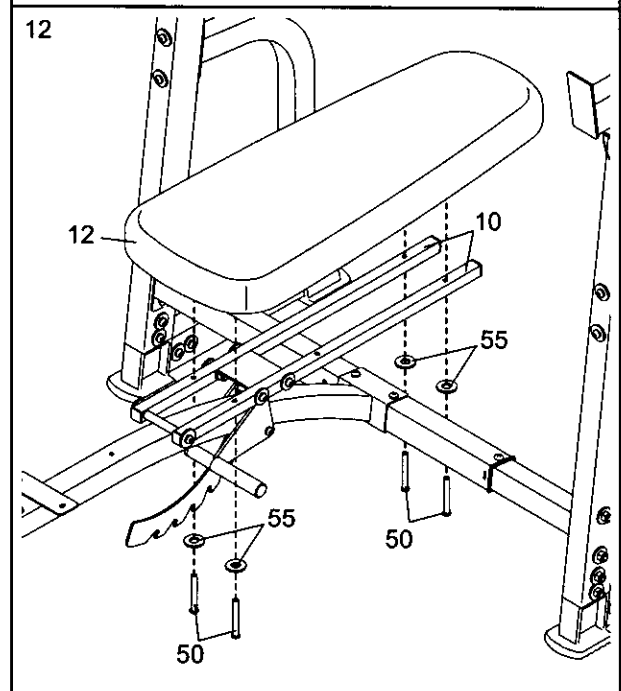

13. Attach the Seat (11) to the Bench Frame (1) with an M6 x 63mm Screw (47), an M6 Washer (55), and two M6 x 16mm Screws (48).

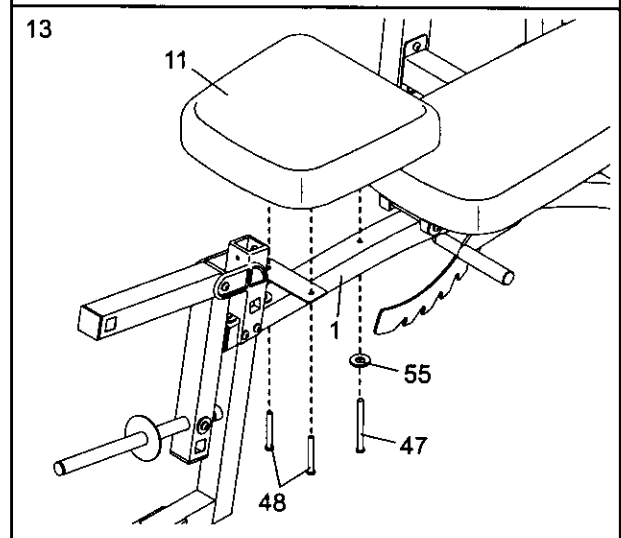

14. Slide a Short Pad Tube (34) into a hole in the Leg Lever (8). Wet both sides of the Pad Tube with soapy water. Slide two Large Pads (35) onto the Pad Tube as shown. Press two Large Pad Caps (36) into the Pad Tube. **Repeat with the other Short Pad Tube and the Leg Lever.**

Slide the Long Pad Tube (66) into the hole in the Leg Station Attachment (14). Wet both sides of the Pad Tube with soapy water. Slide two Small Pads (37) onto the Tube as shown. Press two Small Pad Caps (38) into the Pad Tube.

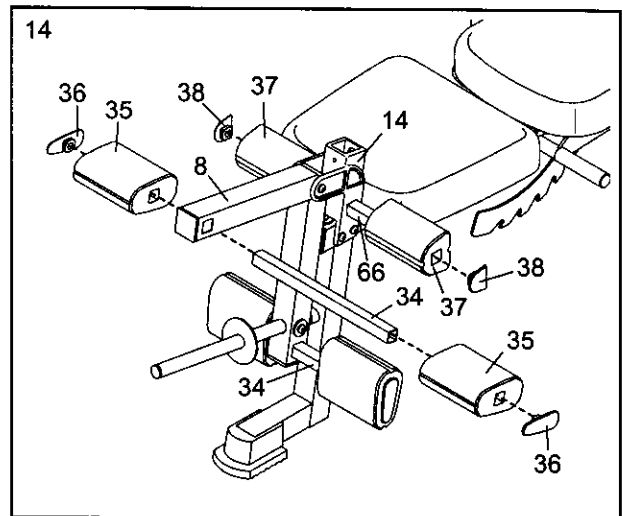

15. Attach the Curl Pad (13) to the Curl Post (9) with two M6 x 16mm Screws (48).

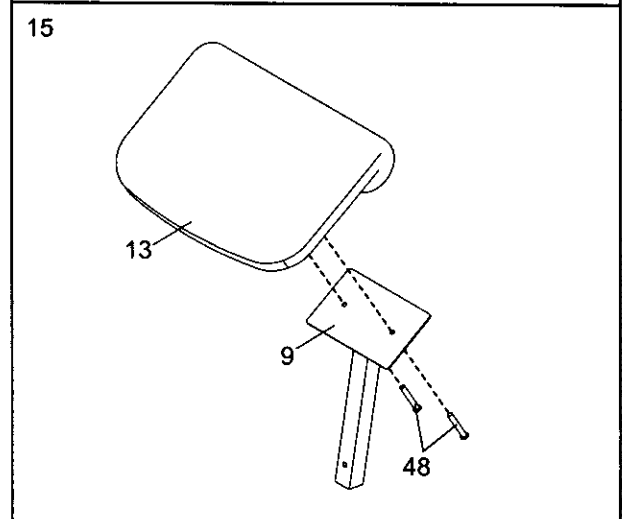

16. **Make sure that that all parts are properly tightened before you use the weight bench.** The use of all remaining parts will be explained in ADJUSTMENTS, beginning on the following page.

# ADJUSTMENTS

The weight bench is designed to be used with your own weight set (not included). The steps below explain how the weight bench can be adjusted. See EXERCISE GUIDELINES on page 13 for important exercise information and refer to the accompanying exercise guide to see the correct form for each exercise. Refer also to the exercise information accompanying your weight set for additional exercises.

Make sure all parts are properly tightened each time the weight bench is used. Replace any worn parts immediately. The weight bench can be cleaned with a damp cloth and a mild, non-abrasive detergent. Do not use solvents.

## ADJUSTING THE BACKREST

To adjust the position of the Backrest (12), hold the upper end of the Backrest with one hand and lift the Adjustment Lever (29) with the other hand, disengaging the Backrest Bracket (16). Raise or lower the Backrest to the desired position. Lower the Adjustment Lever so that the M10 x 72mm Flat Head Screw (not shown) engages one of the notches in the Backrest Bracket.

**▲WARNING:** Always hold the Backrest (12) securely before disengaging the Backrest Bracket (16). Always make sure the Backrest Bracket (16) is fully engaged before using the Backrest.

## ATTACHING WEIGHTS TO THE LEG LEVER

To use the Leg Lever (8), slide the desired weights (not included) onto the Weight Tube (39). Secure the weights with a Weight Clip (23 or 24).

**▲WARNING:** Do not place more than 150 pounds on the Weight Tube (39).

Weights can be added to the Curl Bar (not shown) in the same manner. Secure the weights to the Curl Bar with two Weight Clips (23 or 24). Weights can be stored on the tubes on the Uprights (not shown).

## ADJUSTING THE WEIGHT RESTS

To change the height of the Weight Rests (17, 67 [not shown]), remove the Adjustment Pins (43). Position the Weight Rests at the desired height on the Uprights (5, 68 [not shown]) and secure them with the Adjustment Pins.

**▲WARNING:** Always set both Weight Rests (17, 67) at the same height. Make sure that the Adjustment Pins (43) are wrapped around the back of the Uprights (5, 68).

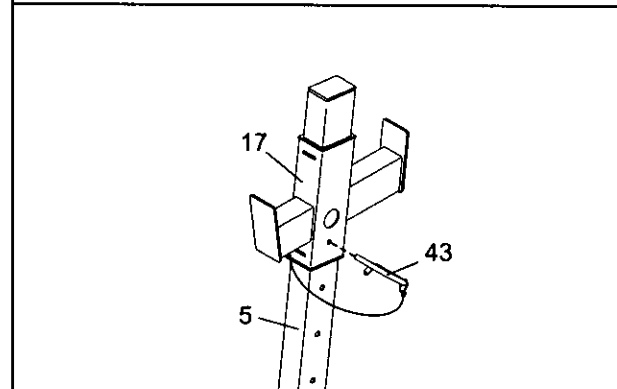
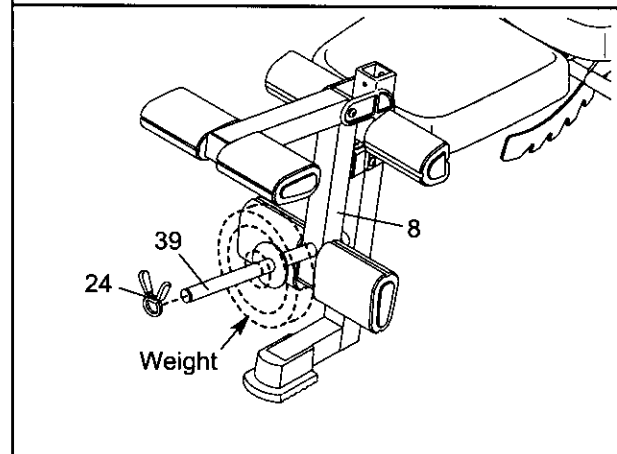
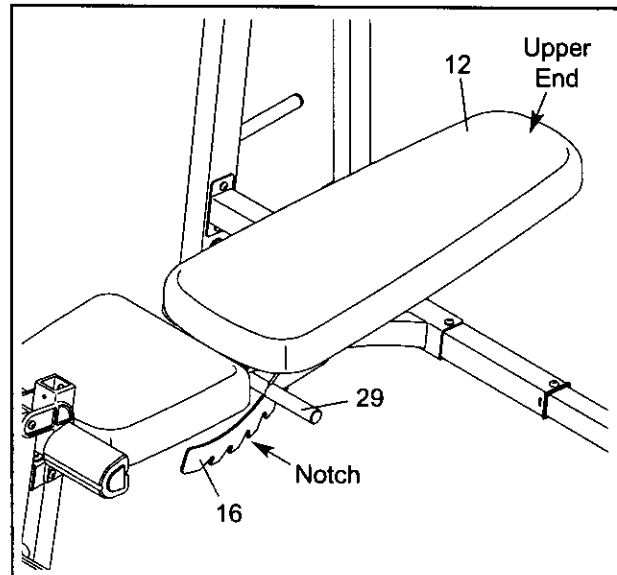

## ADJUSTING THE BENCH WIDTH

To adjust the width of the bench to use either a mid-width barbell or an Olympic barbell, remove the indicated M10 x 72mm Button Screw (44), the M10 Washer (53), the two M10 x 78mm Button Bolt (65), and the two M10 Nylon Locknuts (56) from the Crossbar (3).

Refer to assembly step 6 for instructions on how to reassemble the Crossbar (3) at the desired width.

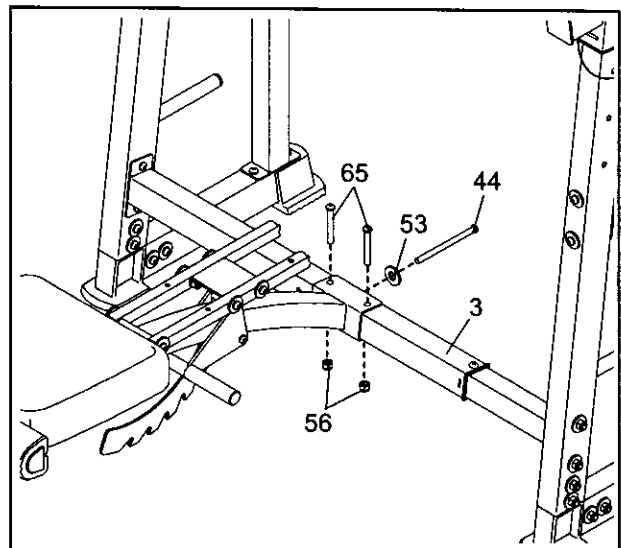

## ATTACHING THE CURL POST

For some exercises, the Curl Post (9) must be attached to the weight bench. Slide the Curl Post into the Leg Station Attachment (14). Align the adjustment holes in the Curl Post with the adjustment hole in the Leg Station Attachment. Tighten the Curl Post Knob (15) into the adjustment hole in the Leg Station Attachment. **Fully tighten the Knob.**

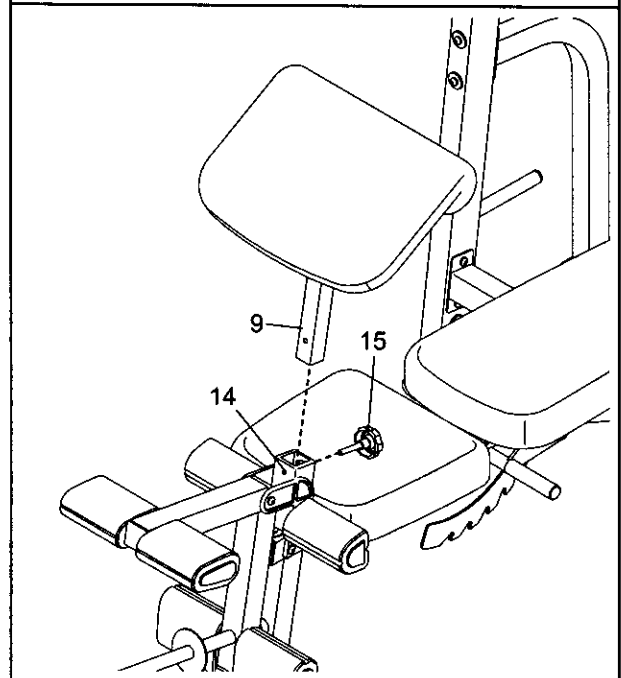

## USING THE OLYMPIC WEIGHT ADAPTER

Press a 48mm Round Inner Cap (22) into the Olympic Adapter (40). Attach the Olympic Adapter to the Weight Tube (39) with a 1/4" x 9mm Allen Head Set Screw (51). **Make sure that the Set Screw is in the bottom of the Adapter.**

Press a 48mm Round Inner Cap (22) into a Curl Bar Olympic Adapter (21). Attach the Curl Bar Olympic Adapter to the Curl Bar (19) with a 1/4" x 9mm Allen Head Set Screw (51). **Attach the other Curl Bar Olympic Adapter to the Curl Bar in the same manner.**

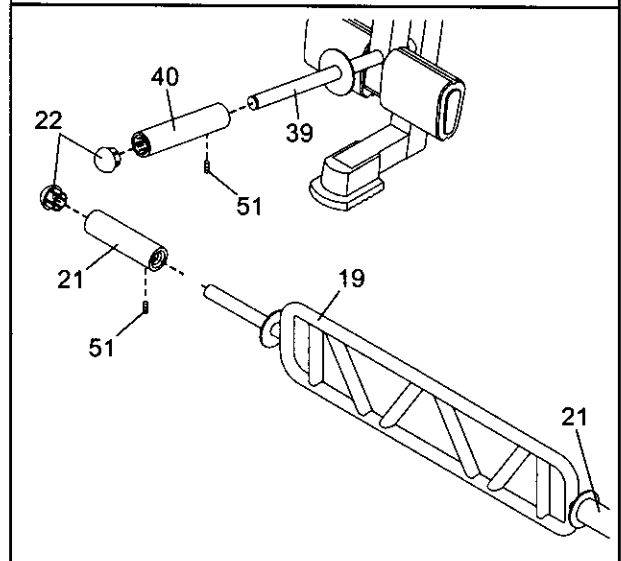

---

# EXERCISE GUIDELINES

## THE FOUR BASIC TYPES OF WORKOUTS

### Muscle Building

To increase the size and strength of your muscles, push them close to their maximum capacity. Your muscles will continually adapt and grow as you progressively increase the intensity of your exercise. You can adjust the intensity level of an individual exercise in two ways:

- by changing the amount of resistance used
- by changing the number of repetitions or sets performed. (A "repetition" is one complete cycle of an exercise, such as one sit-up. A "set" is a series of repetitions.)

The proper amount of resistance for each exercise depends upon the individual user. You must gauge your limits and select the amount of resistance that is right for you. Begin with 3 sets of 8 repetitions for each exercise you perform. Rest for 3 minutes after each set. When you can complete 3 sets of 12 repetitions without difficulty, increase the amount of resistance.

### Toning

You can tone your muscles by pushing them to a moderate percentage of their capacity. Select a moderate amount of resistance and increase the number of repetitions in each set. Complete as many sets of 15 to 20 repetitions as possible without discomfort. Rest for 1 minute after each set. Work your muscles by completing more sets rather than by using high amounts of resistance.

### Weight Loss

To lose weight, use a low amount of resistance and increase the number of repetitions in each set. Exercise for 20 to 30 minutes, resting for a maximum of 30 seconds between sets.

### Cross Training

Cross training is an efficient way to get a complete and well-balanced fitness program. An example of a balanced program is:

- Plan strength training workouts on Monday, Wednesday, and Friday.
- Plan 20 to 30 minutes of aerobic exercise, such as running on a treadmill or riding on an elliptical or exercise bike, on Tuesday and Thursday.
- Rest from both strength training and aerobic exercise for at least one full day each week to give your body time to regenerate.

The combination of strength training and aerobic exercise will reshape and strengthen your body, plus develop your heart and lungs.

## PERSONALIZING YOUR EXERCISE PROGRAM

Determining the exact length of time for each workout, as well as the number of repetitions or sets completed, is an individual matter. It is important to avoid overdoing it during the first few months of your exercise program. You should progress at your own pace and be sensitive to your body's signals. If you experience pain or dizziness at any time while exercising, stop immediately and begin cooling down. Find out what is wrong before continuing. Remember that adequate rest and a proper diet are important factors in any exercise program.

### WARMING UP

Begin each workout with 5 to 10 minutes of stretching and light exercise to warm up. Warming up prepares your body for more strenuous exercise by increasing circulation, raising your body temperature and delivering more oxygen to your muscles.

### WORKING OUT

Each workout should include 6 to 10 different exercises. Select exercises for every major muscle group, emphasizing areas that you want to develop most. To give balance and variety to your workouts, vary the exercises from session to session.

Schedule your workouts for the time of day when your energy level is the highest. Each workout should be followed by at least one day of rest. Once you find the schedule that is right for you, stick with it.

### EXERCISE FORM

Maintaining proper form is an essential part of an effective exercise program. This requires moving through the full range of motion for each exercise, and moving only the appropriate parts of the body. Exercising in an uncontrolled manner will leave you feeling exhausted. On the exercise guide accompanying this manual you will find photographs showing the correct form for several exercises, and a list of the muscles affected. Refer to the muscle chart on the next page to find the names of the muscles.

The repetitions in each set should be performed smoothly and without pausing. The exertion stage of each repetition should last about half as long as the return stage. Proper breathing is important. Exhale during the exertion stage of each repetition and inhale during the return stroke. Never hold your breath.

Rest for a short period of time after each set. The ideal resting periods are:

- Rest for three minutes after each set for a muscle building workout.
- Rest for one minute after each set for a toning workout.
- Rest for 30 seconds after each set for a weight loss workout.

Plan to spend the first couple of weeks familiarizing yourself with the equipment and learning the proper form for each exercise.

### COOLING DOWN

End each workout with 5 to 10 minutes of stretching. Include stretches for both your arms and legs. Move

slowly as you stretch and do not bounce. Ease into each stretch gradually and go only as far as you can without strain. Stretching at the end of each workout is an effective way to increase flexibility.

### STAYING MOTIVATED

For motivation, keep a record of each workout. The chart on page 15 of this manual can be photocopied and used to schedule and record your workouts. List the date, the exercises performed, the resistance used, and the numbers of sets and repetitions completed. Record your weight and key body measurements at the end of every month. Remember, the key to achieving the greatest results is to make exercise a regular and enjoyable part of your everyday life.

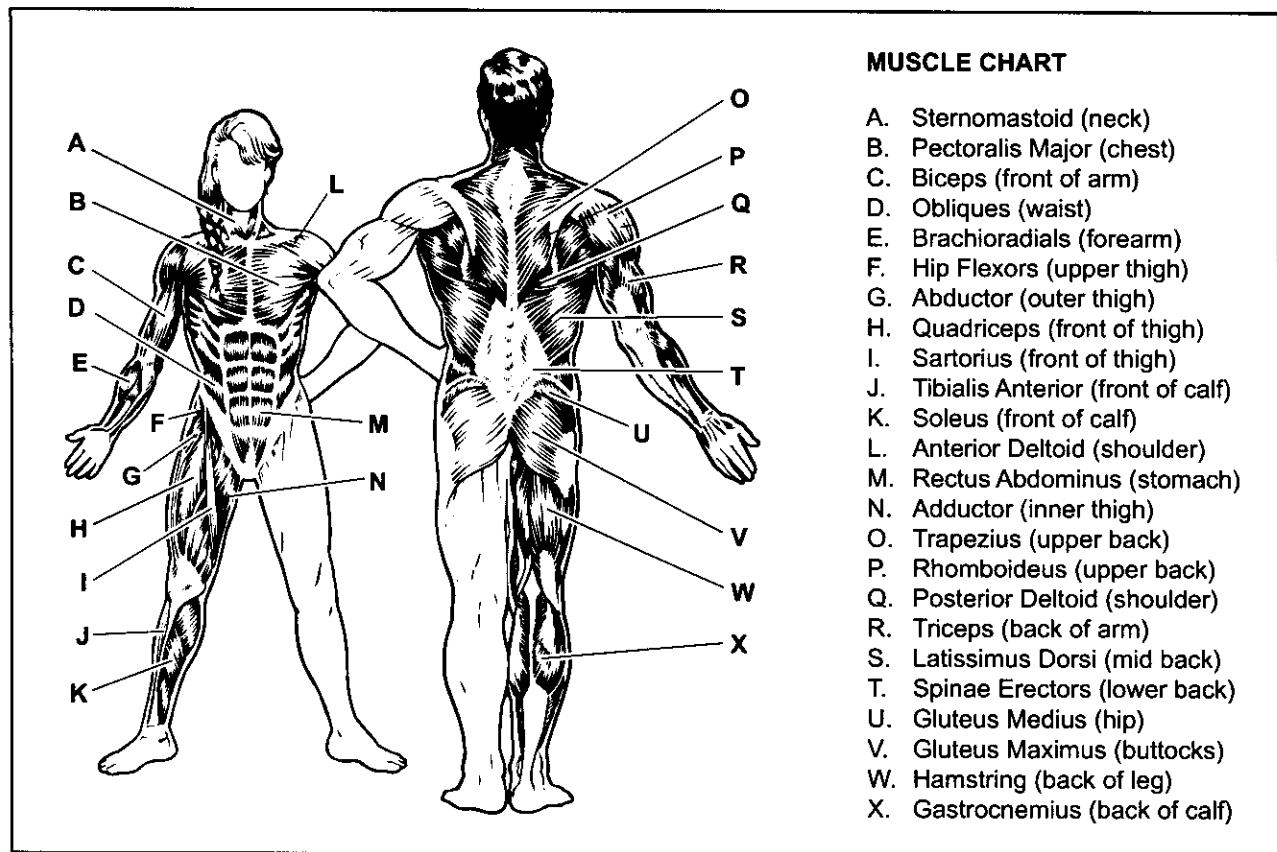

### MUSCLE CHART

- A. Sternomastoid (neck)
- B. Pectoralis Major (chest)
- C. Biceps (front of arm)
- D. Obliques (waist)
- E. Brachioradials (forearm)
- F. Hip Flexors (upper thigh)
- G. Abductor (outer thigh)
- H. Quadriceps (front of thigh)
- I. Sartorius (front of thigh)
- J. Tibialis Anterior (front of calf)
- K. Soleus (front of calf)
- L. Anterior Deltoid (shoulder)
- M. Rectus Abdominus (stomach)
- N. Adductor (inner thigh)
- O. Trapezius (upper back)
- P. Rhomboideus (upper back)
- Q. Posterior Deltoid (shoulder)
- R. Triceps (back of arm)
- S. Latissimus Dorsi (mid back)
- T. Spinae Erectors (lower back)
- U. Gluteus Medius (hip)
- V. Gluteus Maximus (buttocks)
- W. Hamstring (back of leg)
- X. Gastrocnemius (back of calf)

|  |                 |               |             |             |
|--|-----------------|---------------|-------------|-------------|
| <b>MONDAY</b><br>Date: _____ / ____ / ____ | <b>EXERCISE</b> | <b>WEIGHT</b> | <b>SETS</b> | <b>REPS</b> |
|  |                 |               |             |             |
|  |                 |               |             |             |
|  |                 |               |             |             |
|  |                 |               |             |             |
|  |                 |               |             |             |
|  |                 |               |             |             |
|  |                 |               |             |             |
|  |                 |               |             |             |
|  |                 |               |             |             |

---

**TUESDAY      AEROBIC EXERCISE**

Date: \_\_\_\_\_ / \_\_\_\_ / \_\_\_\_

|   |                 |               |             |             |
|---|-----------------|---------------|-------------|-------------|
| <b>WEDNESDAY</b><br>Date: _____ / ____ / ____ | <b>EXERCISE</b> | <b>WEIGHT</b> | <b>SETS</b> | <b>REPS</b> |
|   |                 |               |             |             |
|   |                 |               |             |             |
|   |                 |               |             |             |
|   |                 |               |             |             |
|   |                 |               |             |             |
|   |                 |               |             |             |
|   |                 |               |             |             |
|   |                 |               |             |             |
|   |                 |               |             |             |

---

**THURSDAY      AEROBIC EXERCISE**

Date: \_\_\_\_\_ / \_\_\_\_ / \_\_\_\_

|  |                 |               |             |             |
|--|-----------------|---------------|-------------|-------------|
| <b>FRIDAY</b><br>Date: _____ / ____ / ____ | <b>EXERCISE</b> | <b>WEIGHT</b> | <b>SETS</b> | <b>REPS</b> |
|  |                 |               |             |             |
|  |                 |               |             |             |
|  |                 |               |             |             |
|  |                 |               |             |             |
|  |                 |               |             |             |
|  |                 |               |             |             |
|  |                 |               |             |             |
|  |                 |               |             |             |
|  |                 |               |             |             |

Make photocopies of this page for scheduling and recording your workouts.

# PART IDENTIFICATION CHART

This chart is provided to help you identify the small parts used in assembly. The number in parenthesis below each part refers to the key number of the part, from the PART LIST in the center of this manual. **Important:** Some parts may have been pre-assembled for shipping purposes. If you cannot find a part in the parts bags, check to see if it has been pre-assembled. If a part is missing, call toll-free 1-800-999-3756.

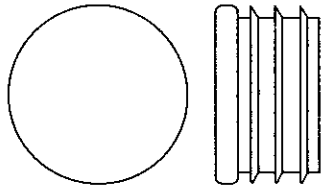

25mm Round Inner Cap (20)

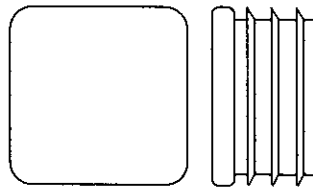

25mm Square Inner Cap (26)

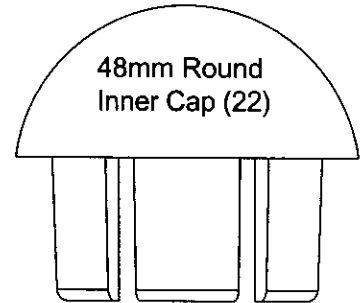

48mm Round Inner Cap (22)

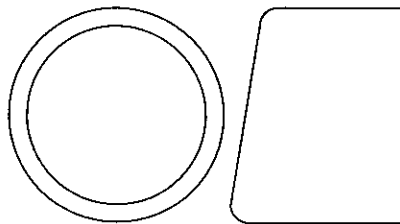

25mm Round Angle Cap (60)

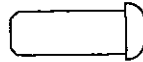

M6 x 16mm Screw (48)

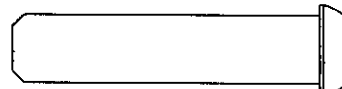

M10 x 43mm Button Bolt (49)

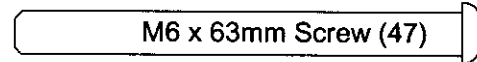

M6 x 63mm Screw (47)

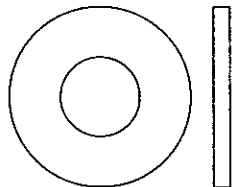

M10 Washer (53)

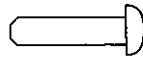

M4 x 16mm Screw (52)

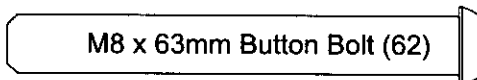

M8 x 63mm Button Bolt (62)



1/4" x 9mm Allen Head Set Screw (51)



M10 x 68mm Button Bolt (64)



M8 Nylon Locknut (58)



M10 x 72mm Flat Head Screw (46)

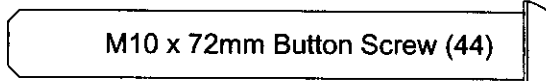

M10 x 72mm Button Screw (44)

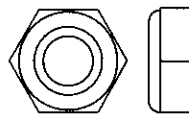

M10 Nylon Jamnut (69)

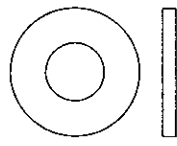

M8 Washer (54)

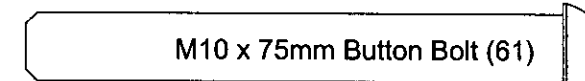

M10 x 75mm Button Bolt (61)

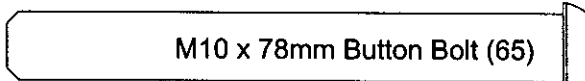

M10 x 78mm Button Bolt (65)



M10 Nylon Locknut (56)



M6 Washer (55)

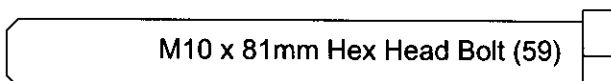

M10 x 81mm Hex Head Bolt (59)

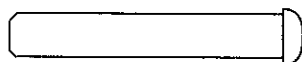

M6 x 38mm Screw (50)

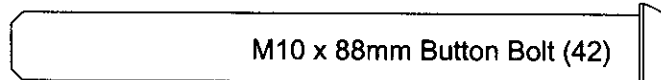

M10 x 88mm Button Bolt (42)

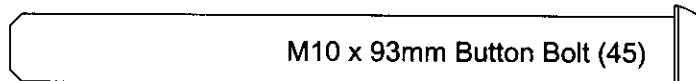

M10 x 93mm Button Bolt (45)

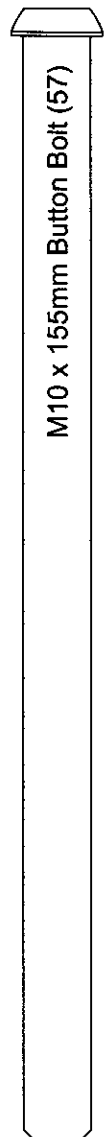

M10 x 155mm Button Bolt (57)



# PART LIST—Model No. 831.150320

R0803B

| Key No. | Qty. | Description              | Key No. | Qty. | Description                     |
|---------|------|--------------------------|---------|------|---------------------------------|
| 1       | 1    | Bench Frame              | 39      | 1    | Weight Tube                     |
| 2       | 1    | Bench Base               | 40      | 1    | Olympic Adapter                 |
| 3       | 1    | Crossbar                 | 41      | 2    | Adjustment Lever Bushing        |
| 4       | 1    | Inner Crossbar           | 42      | 1    | M10 x 88mm Button Bolt          |
| 5       | 1    | Right Upright            | 43      | 2    | Adjustment Pin                  |
| 6       | 2    | Stabilizer               | 44      | 5    | M10 x 72mm Button Screw         |
| 7       | 2    | Support                  | 45      | 10   | M10 x 93mm Button Bolt          |
| 8       | 1    | Leg Lever                | 46      | 1    | M10 x 72mm Flat Head Screw      |
| 9       | 1    | Curl Post                | 47      | 1    | M6 x 63mm Screw                 |
| 10      | 2    | Backrest Tube            | 48      | 4    | M6 x 16mm Screw                 |
| 11      | 1    | Seat                     | 49      | 4    | M10 x 43mm Button Bolt          |
| 12      | 1    | Backrest                 | 50      | 4    | M6 x 38mm Screw                 |
| 13      | 1    | Curl Pad                 | 51      | 3    | 1/4" x 9mm Allen Head Set Screw |
| 14      | 1    | Leg Station Attachment   | 52      | 7    | M4 x 16mm Screw                 |
| 15      | 1    | Curl Post Knob           | 53      | 33   | M10 Washer                      |
| 16      | 1    | Backrest Bracket         | 54      | 2    | M8 Washer                       |
| 17      | 1    | Right Weight Rest        | 55      | 5    | M6 Washer                       |
| 18      | 4    | Weight Rest Bushing      | 56      | 33   | M10 Nylon Locknut               |
| 19      | 1    | Curl Bar                 | 57      | 1    | M10 x 155mm Button Bolt         |
| 20      | 5    | 25mm Round Inner Cap     | 58      | 1    | M8 Nylon Locknut                |
| 21      | 2    | Curl Bar Olympic Adapter | 59      | 2    | M10 x 81mm Hex Head Bolt        |
| 22      | 3    | 48mm Round Inner Cap     | 60      | 1    | 25mm Round Angled Cap           |
| 23      | 2    | 48mm Weight Clip         | 61      | 1    | M10 x 75mm Button Bolt          |
| 24      | 2    | 1" Weight Clip           | 62      | 1    | M8 x 63mm Button Bolt           |
| 25      | 2    | 2" x 3" Inner Cap        | 63      | 1    | Crossbar Cap                    |
| 26      | 4    | 25mm Square Inner Cap    | 64      | 10   | M10 x 68mm Button Bolt          |
| 27      | 2    | Notched Square Inner Cap | 65      | 2    | M10 x 78mm Button Bolt          |
| 28      | 2    | 50mm Square Inner Cap    | 66      | 1    | Long Pad Tube                   |
| 29      | 1    | Adjustment Lever         | 67      | 1    | Left Weight Rest                |
| 30      | 1    | Lever Handgrip           | 68      | 1    | Left Upright                    |
| 31      | 1    | 10mm Spacer              | 69      | 2    | M10 Nylon Jamnut                |
| 32      | 2    | Base Foot                | 70      | 1    | Small Base Foot                 |
| 33      | 2    | Upright Foot             | 71      | 2    | Support Plate                   |
| 34      | 2    | Short Pad Tube           | #       | 1    | User's Manual                   |
| 35      | 4    | Large Pad                | #       | 1    | Exercise Guide                  |
| 36      | 4    | Large Pad Cap            | #       | 3    | Allen Wrench                    |
| 37      | 2    | Small Pad                | #       | 1    | Grease Pack                     |
| 38      | 2    | Small Pad Cap            |         |      |                                 |

"#" Indicates a non-illustrated part. Specifications are subject to change without notice. See the back cover of this manual for information on ordering replacement parts. If a part is missing, call toll-free 1-800-999-3756.

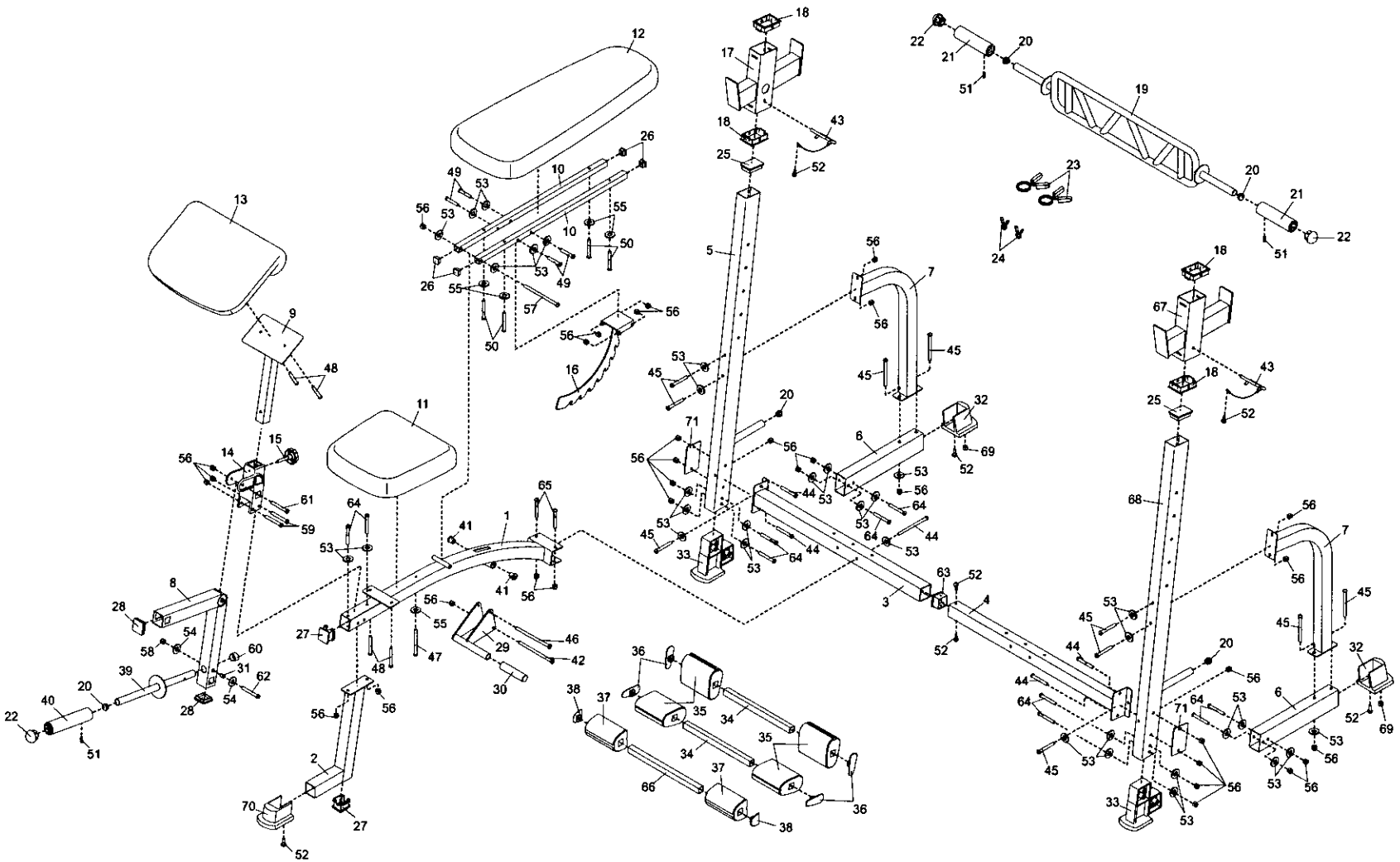

EXPLODED DRAWING—Model No. 831.150320

R0803B

# Get it fixed, at your home or ours!

## Your Home

For repair – **in your home** – of **all** major brand appliances, lawn and garden equipment, or heating and cooling systems, **no matter who made it, no matter who sold it!**

For the replacement parts, accessories, and user's manuals that you need to do-it-yourself.

For Sears professional installation of home appliances and items like garage door openers and water heaters.

**1-800-4-MY-HOME®**

(1-800-469-4663)

[www.sears.com](http://www.sears.com)

Anytime, day or night

(U.S.A. and Canada)

[www.sears.ca](http://www.sears.ca)

## Our Home

For repair of carry-in products like vacuums, lawn equipment, and electronics, call or go on-line for the location of your nearest **Sears Parts and Repair Center.**

**1-800-488-1222** Anytime, day or night (U.S.A. only)

[www.sears.com](http://www.sears.com)

To purchase a protection agreement (U.S.A.) or maintenance agreement (Canada) on a product serviced by Sears:

**1-800-827-6655** (U.S.A.)

**1-800-361-6665** (Canada)

Para pedir servicio de reparación a domicilio, y para ordenar piezas:

**1-888-SU-HOGAR<sup>SM</sup>** (1-888-784-6427)

# SEARS

® Registered Trademark / <sup>TM</sup> Trademark / <sup>SM</sup> Service Mark of Sears, Roebuck and Co.  
© Marca Registrada / <sup>TM</sup> Marca de Fábrica / <sup>SM</sup> Marca de Servicio de Sears, Roebuck and Co.

## FULL 90-DAY WARRANTY

For 90 days from the date of purchase, if failure occurs due to defect in material or workmanship in this WEIGHT BENCH EXERCISER, contact the nearest Sears Service Center throughout the United States and Sears will repair or replace the WEIGHT BENCH EXERCISER, free of charge.

This warranty does not apply when the WEIGHT BENCH EXERCISER is used commercially or for rental purposes.

This warranty gives you specific legal rights, and you may also have other rights which vary from state to state.

**Sears, Roebuck and Co., Dept 817WA, Hoffman Estates, IL 60179**