



NordicTrack®

SL 720

Patent Pending

USER'S MANUAL

Model No. NTC69020

Serial No. _____

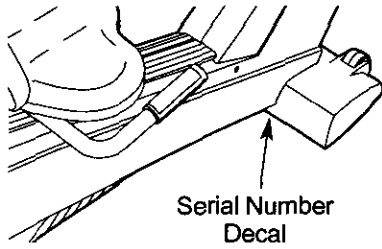

QUESTIONS?

As a manufacturer, we are committed to providing complete customer satisfaction. If you have questions, or if there are missing parts, we will guarantee satisfaction through direct assistance from our factory.

TO AVOID DELAYS, PLEASE CALL DIRECT TO OUR TOLL-FREE CUSTOMER HOT LINE. The trained technicians on our customer hot line will provide immediate assistance, free of charge to you.

CUSTOMER HOT LINE:

1-888-825-2588

Mon.-Fri., 6 a.m.-6 p.m. MST

CAUTION

Read all precautions and instructions in this manual before using this equipment. Keep this manual for future reference.

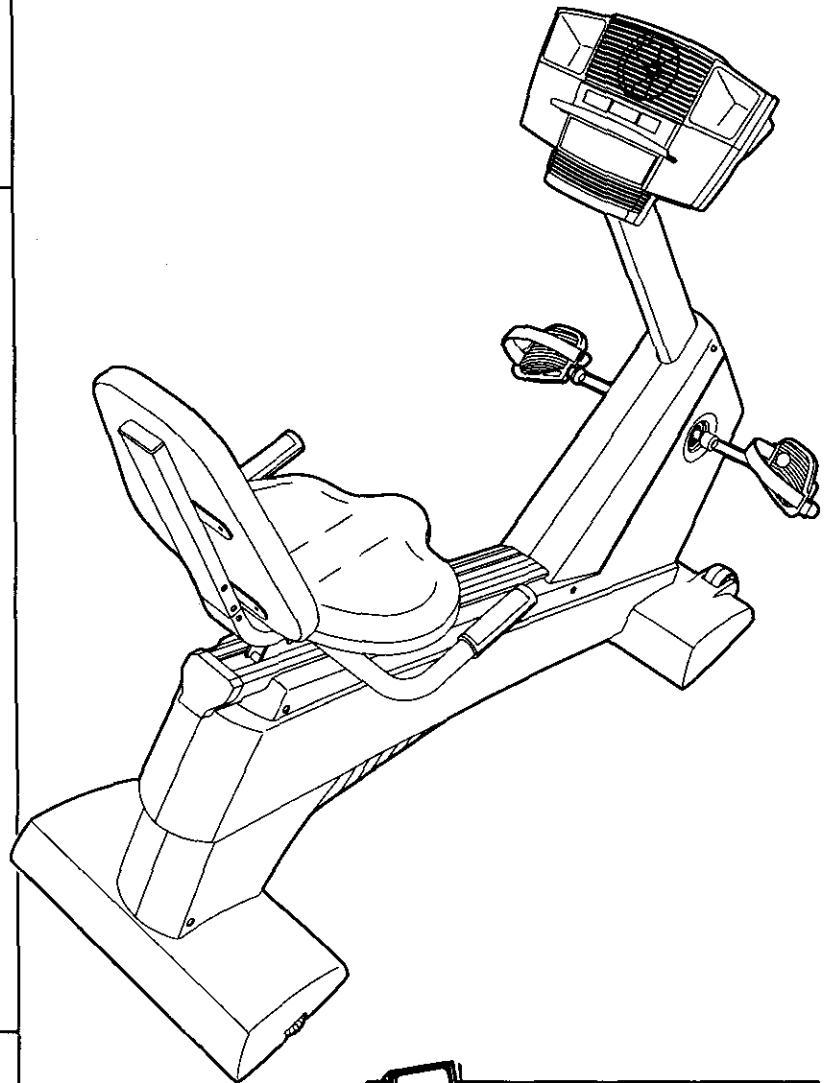

Visit our website at

www.nordictrack.com

*new products, prizes,
fitness tips, and much more!*



TABLE OF CONTENTS

| | |
|---|-------------|
| IMPORTANT PRECAUTIONS | .3 |
| BEFORE YOU BEGIN | .4 |
| ASSEMBLY | .5 |
| HOW TO OPERATE THE EXERCISE CYCLE | .10 |
| MAINTENANCE AND TROUBLESHOOTING | .22 |
| EXERCISE GUIDELINES | .23 |
| PART LIST | .25 |
| EXPLODED DRAWING | .26 |
| HOW TO ORDER REPLACEMENT PARTS | .Back Cover |
| LIMITED WARRANTY | .Back Cover |

IMPORTANT PRECAUTIONS

▲ WARNING: To reduce the risk of serious injury, read the following important precautions before using the exercise cycle.

1. Read all instructions in this manual before using the exercise cycle. Use the exercise cycle only as described.
2. It is the responsibility of the owner to ensure that all users of the exercise cycle are adequately informed of all precautions.
3. Use the exercise cycle indoors on a level surface. Keep the exercise cycle away from moisture and dust. Place a mat under the exercise cycle to protect the floor or carpet.
4. Inspect and properly tighten all parts regularly. Replace any worn parts immediately.
5. Keep children under the age of 12 and pets away from the exercise cycle at all times.
6. The exercise cycle should not be used by persons weighing more than 250 pounds.
7. Wear suitable clothing when using the exercise cycle; do not wear loose clothing that could become caught on the exercise cycle. Always wear athletic shoes.
8. Always keep your back straight when using the exercise cycle. Do not arch your back.
9. If you feel pain or dizziness while exercising, stop immediately and cool down.
10. The pulse sensor is not a medical device. Various factors, including the user's movement, may affect the accuracy of heart rate readings. The pulse sensor is intended only as an exercise aid in determining heart rate trends in general.
11. The exercise cycle is intended for in-home use only. Do not use the exercise cycle in a commercial, rental, or institutional setting.

▲ WARNING: Before beginning this or any exercise program, consult your physician. This is especially important for persons over the age of 35 or persons with pre-existing health problems. Read all instructions before using. ICON assumes no responsibility for personal injury or property damage sustained by or through the use of this product.

BEFORE YOU BEGIN

Congratulations for selecting the new NordicTrack® SL 720 exercise cycle. Cycling is one of the most effective exercises for increasing cardiovascular fitness, building endurance, and toning the entire body. The NordicTrack® SL 720 offers an impressive array of features designed to let you enjoy this healthful exercise in the comfort and privacy of your home.

For your benefit, read this manual carefully before you use the exercise cycle. If you have questions after reading this manual, call our Customer Service

Department toll-free at 1-888-825-2588, Monday through Friday, 6 a.m. until 6 p.m. Mountain Time (excluding holidays). To help us assist you, mention the product model number and serial number when calling. The model number is NTC69020. The serial number can be found on a decal attached to the exercise cycle (see the front cover of this manual for the location of the decal).

Before reading further, please familiarize yourself with the parts that are labeled in the drawing below.

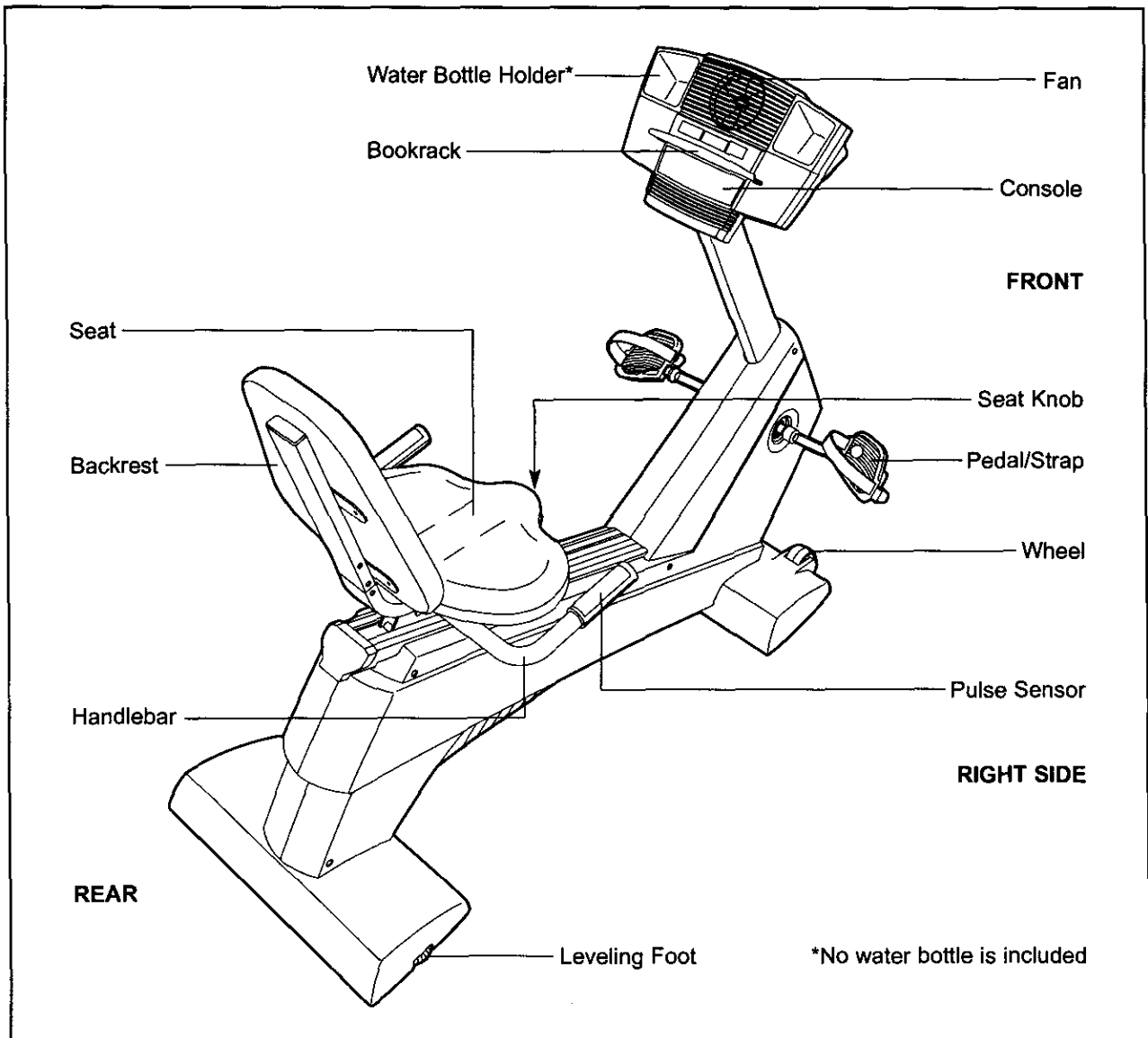

ASSEMBLY

Assembly requires two persons. Place all parts of the exercise cycle in a cleared area and remove the packing materials. Do not dispose of the packing materials until assembly is completed.

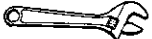
Assembly requires the included tools and your own adjustable wrench .

Use the drawings below to identify the small parts used in assembly. The number in parenthesis below each drawing refers to the key number of the part, from the PART LIST on page 25. The second number refers to the quantity needed for assembly. **Note: Some small parts may have been pre-assembled for shipping. If a part is not in the parts bag, check to see if it has been pre-assembled.**

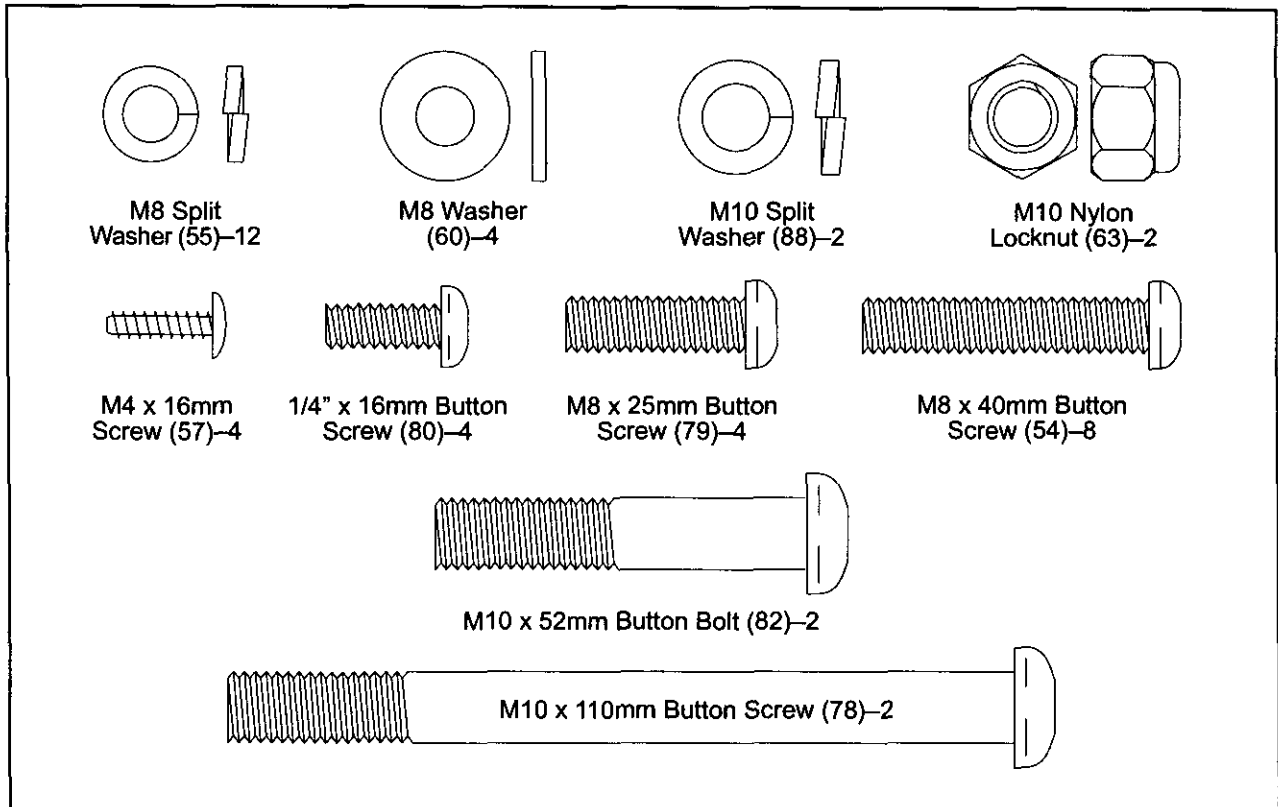

1. Identify the Front Stabilizer (15). While another person lifts the front of the Frame (1), attach the Front Stabilizer to the Frame with four M8 x 40mm Button Screws (54) and four M8 Split Washers (55).

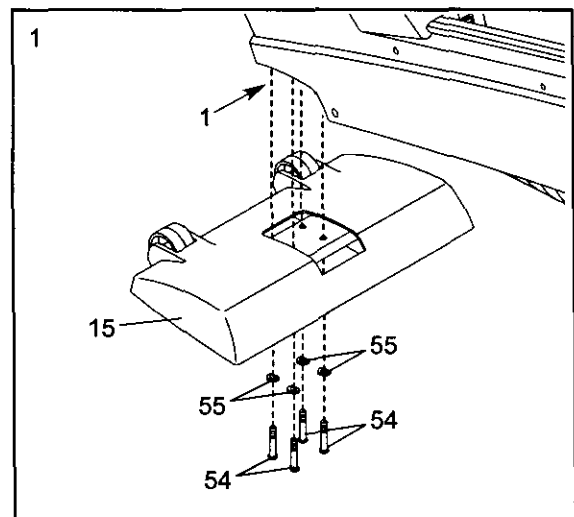

2. While another person lifts the rear of the Frame (1), attach the Rear Stabilizer (16) to the Frame with four M8 x 40mm Button Screws (54) and four M8 Split Washers (55).

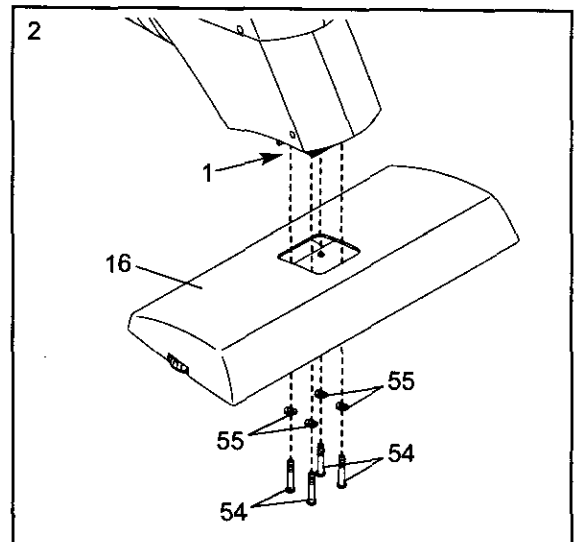

3. Have another person hold the Upright (2) in the position shown. Refer to the inset drawing. Locate the wire extending from the bottom of the Upright. Tie the wire around the ends of the Wire Harness (43) and the Pulse Wire (3) as shown. Carefully pull the wire up through the Upright until the Wire Harness and the Pulse Wire are extending from the top of the Upright. Untie the wire and discard it. **Carefully pull the ends of the Wire Harness and the Pulse Wire to remove any slack.**

Insert the Upright (2) into the Frame (1). **Be careful to avoid pinching the Wire Harness (43) or the Pulse Wire (3).** Attach the Upright with two M10 x 110mm Button Screws (78) and two M10 Split Washers (88).

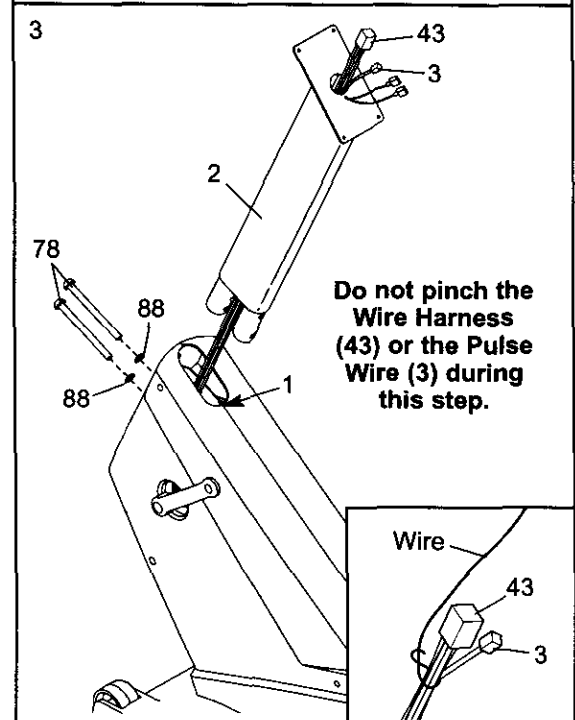

4. Have another person hold the Console (4) near the Upright (2).

Connect the Wire Harness (43) to the wire harness on the Console (4). Connect the Pulse Wire (3) to the pulse wire on the Console. Next, locate the two ground wires that are connected with a screw to the Upright (2). Connect the ground wires to the two smallest wires on the Console.

Carefully insert all excess wiring down into the Upright (2). Attach the Console (4) to the Upright with four M4 x 16mm Screws (57). **Be careful to avoid pinching the wires.**

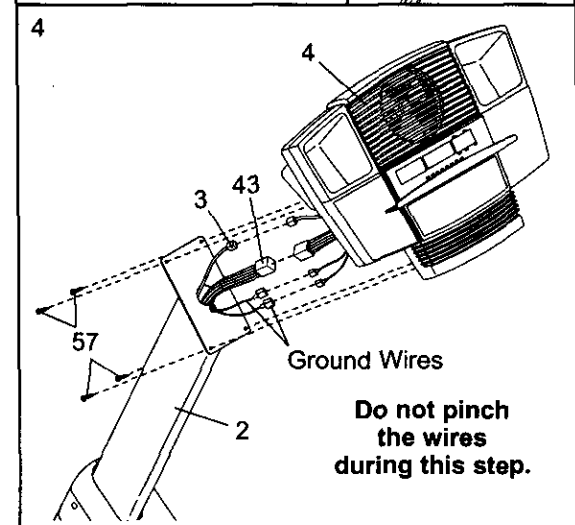

5. Attach the Seat (9) to the Seat Frame (7) with four 1/4" x 16mm Button Screws (80) and four M8 Washers (60).

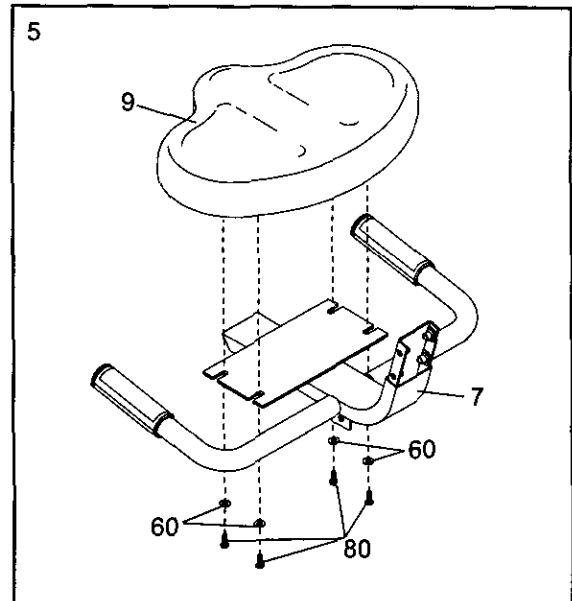

6. Make sure that the Seat Carriage (11) is in the position shown. If necessary, pull the Seat Knob (10) and slide the Seat Carriage forward.

Have another person hold the Seat Frame (7) near the Seat Carriage (11). Locate the two pulse wires extending from the Seat Frame. Connect each pulse wire to the pulse wire of the same color in the Seat Carriage. Insert the excess wiring up into the Seat Frame, and set the Seat Frame on the Seat Carriage. Attach the Seat Frame with two M10 x 52mm Button Bolts (82) and two M10 Nylon Locknuts (63). **Be careful to avoid damaging the pulse wires with the Bolts.**

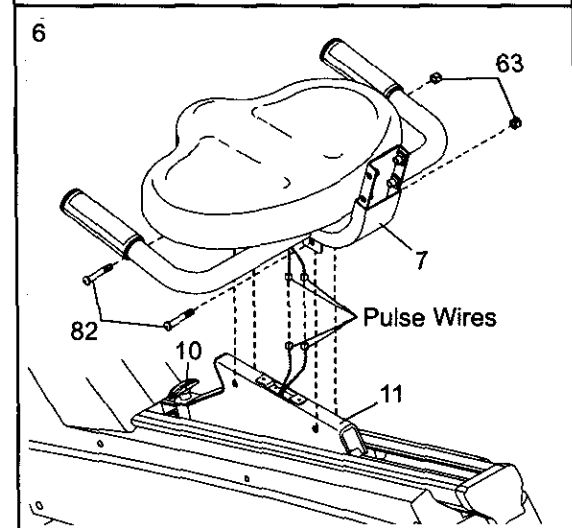

7. Attach the Backrest (62) to the Backrest Frame (42) with four 1/4" x 16mm Button Screws (80).

Slide the Backrest Frame (42) onto the Seat Frame (7). Attach the Backrest Frame with four M8 x 25mm Button Screws (79) and four M8 Split Washers (55).

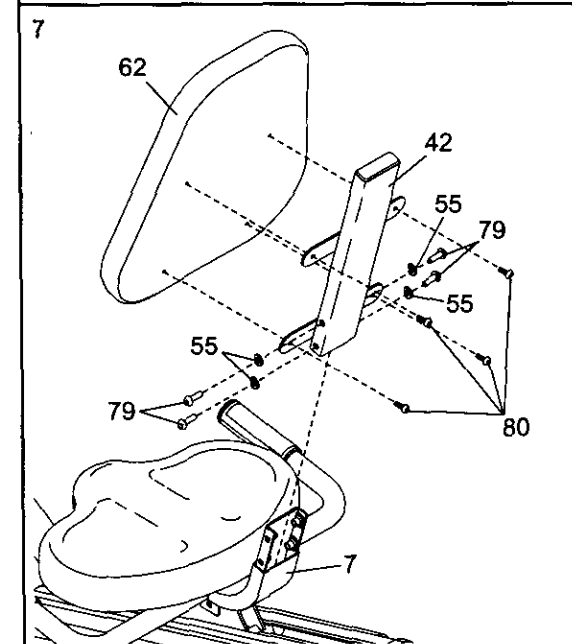

8. Identify the Left Pedal (22), which is marked with an "L." Using an adjustable wrench, **firmly tighten** the Left Pedal *counterclockwise* into the Left Crank Arm (24). Tighten the Right Pedal (not shown) *clockwise* into the Right Crank Arm. **Important: Tighten both Pedals as firmly as possible. After using the exercise cycle for one week, retighten the Pedals. For best performance, the Pedals must be kept tightened.**

Identify the Left Pedal Strap (25), which is marked with an "L." Attach the Left Pedal Strap to the Left Pedal (22), and adjust it to the desired position. Attach and adjust the Right Pedal Strap (not shown) in the same way.

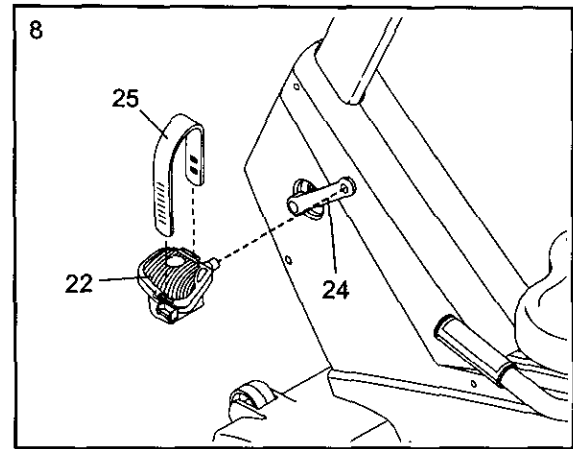

9. **Make sure that all parts are properly tightened before you use the exercise cycle.** Note: After assembly is completed, some extra parts may be left over. Place a mat beneath the exercise cycle to protect the floor.

INSTALLING THE RECEIVER FOR THE OPTIONAL CHEST PULSE SENSOR

If you purchase the optional chest pulse sensor (see page 21), follow the steps below to install the receiver included with the chest pulse sensor.

Remove the access door from the underside of the Console (4). You may need to use a small standard screwdriver to remove the access door.

Slide the receiver onto the indicated plastic pin on the Console (4); **make sure that the receiver is oriented exactly as shown**. Locate the two small screws included with the chest pulse sensor. Attach the receiver to the Console with the two screws as shown.

Connect the wire on the receiver to the indicated wire on the Console (4).

Reattach the access door. **Make sure that no wires are pinched**. Note: The other wires included with the chest pulse sensor may be discarded.

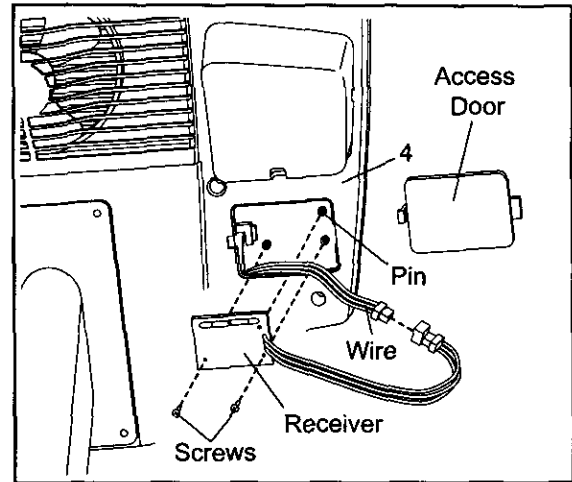

HOW TO OPERATE THE EXERCISE CYCLE

HOW TO MOVE AND LEVEL THE EXERCISE CYCLE

Stand in back of the exercise cycle, and lift the exercise cycle until it can be moved on the front wheels. Move the exercise cycle to the desired location and carefully lower it. **Due to the weight of the exercise cycle, use extreme caution while moving it.**

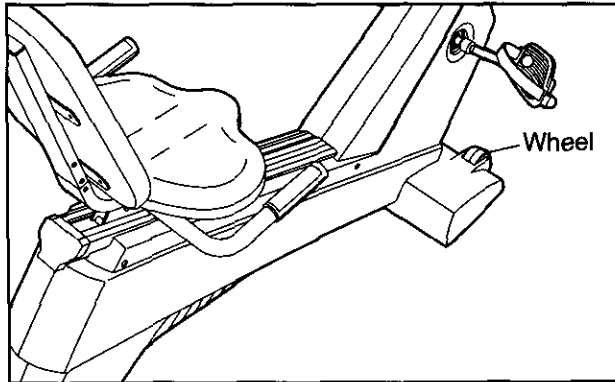

If the exercise cycle rocks slightly during use, turn the leveling feet under the rear stabilizer until the rocking motion is eliminated.

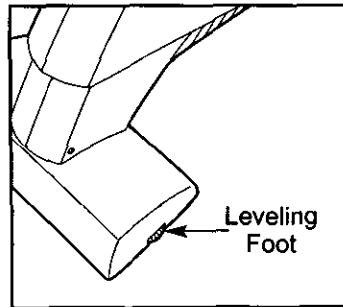

HOW TO ADJUST THE SEAT

The seat can be adjusted to the position that is the most comfortable for you. To adjust the seat, pull the seat knob, slide the seat forward or backward, and then release the seat knob. Move the seat forward or backward slightly until the pin on the seat knob snaps into one of the holes in the seat rail.

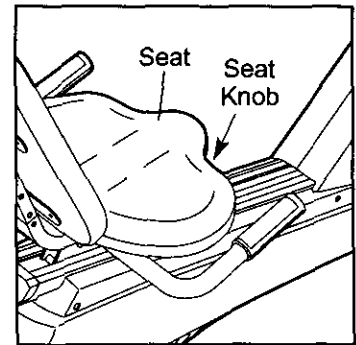

HOW TO ADJUST THE PEDAL STRAPS

The pedal straps can be adjusted to the position that is the most comfortable for you. Press the tabs on the pedals, adjust the straps to the desired position, and then release the tabs.

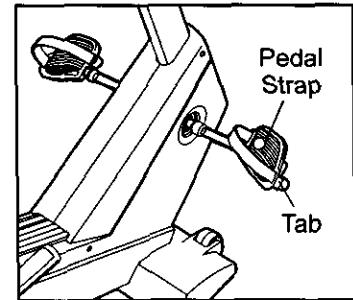

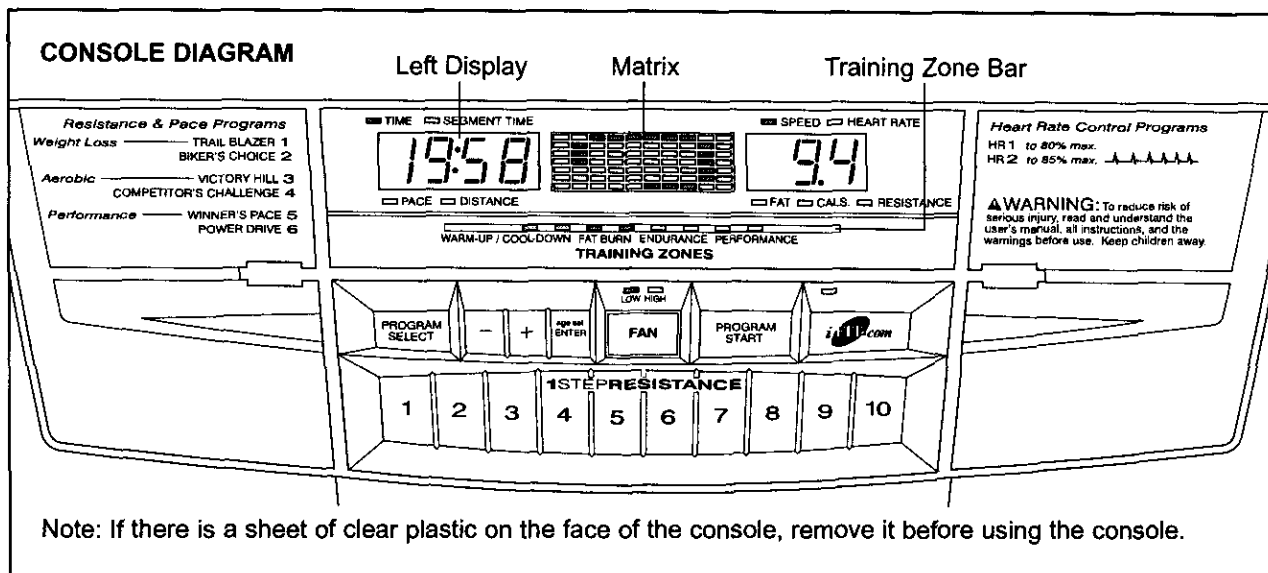

FEATURES OF THE CONSOLE

The advanced console offers a selection of features designed to make your workouts more enjoyable and effective. When the manual mode of the console is selected, the resistance of the exercise cycle can be changed with a touch of a button. As you exercise, the console will provide continuous exercise feedback. You can even measure your heart rate using the hand-grip pulse sensor. Note: For information about an optional chest pulse sensor, see page 21.

The console also offers six resistance and pace programs. Each program automatically changes the resistance of the exercise cycle and prompts you to increase or decrease your pace as it guides you through an effective workout.

In addition, the console features two heart rate programs that automatically change the resistance of the exercise cycle and prompt you to vary your pace to keep your heart rate near a target heart rate as you exercise.

The console also features new iFIT.com interactive technology. Having iFIT.com technology is like having a

personal trainer in your home. Using the included audio cable, you can connect the exercise cycle to your home stereo, portable stereo, or computer and play special iFIT.com CD programs (CD's are available separately). iFIT.com CD programs automatically control the resistance of the exercise cycle and prompt you to vary your pace as a personal trainer coaches you through every step of your workout. High-energy music provides added motivation. Each CD features two programs designed by certified personal trainers.

In addition, you can connect the exercise cycle to your VCR and TV and play iFIT.com video programs (videocassettes are available separately). Video programs offer the same benefits as iFIT.com CD programs, and add the excitement of working out with a class and an instructor.

With the exercise cycle connected to your computer, you can also go to our Web site at www.iFIT.com and access programs directly from the internet. Explore www.iFIT.com for details.

To purchase iFIT.com CD's and videocassettes, call toll-free 1-800-735-0768.

HOW TO USE THE MANUAL MODE

1 Begin pedaling to activate the console.

The exercise cycle requires no batteries or external power source. Power is supplied by a generator as you pedal. To activate the console, begin pedaling at a speed of about 3 miles per hour or faster. After a few seconds, the console displays will light. A tone will then sound and the console will be ready for use.

2 Select the manual mode.

When the power is turned on, the manual mode will be selected. If you have selected a program or the iFIT.com mode, select the manual mode by pressing the Program Select button repeatedly until a track appears in the matrix.

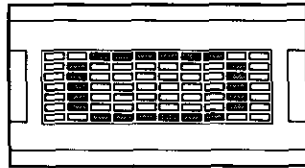

3 Begin pedaling and change the resistance of the exercise cycle as desired.

As you pedal, change the resistance of the exercise cycle by pressing the Resistance buttons. There are ten resistance levels. Note: After the Resistance buttons are pressed, it will take a moment for the exercise cycle to reach the selected resistance level.

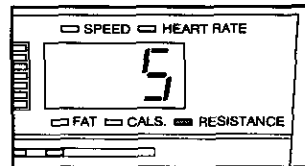

4 Monitor your progress with the matrix, the Training Zone bar, and the two displays.

The matrix— When the manual mode or the iFIT.com mode is selected, the matrix will show a

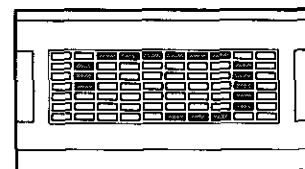

track representing 1/4 mile. As you exercise, the indicators around the track will light, one at a time, until the entire track is lit. When you have completed a lap, a new lap will begin.

The Training Zone bar—

The Training Zone bar will show your pace and the approximate intensity level of your exercise. For example, if three or four indicators in the bar are lit, the bar shows that your pace is ideal for fat burning.

During programs, the Training Zone bar will also prompt you to increase or decrease your pace.

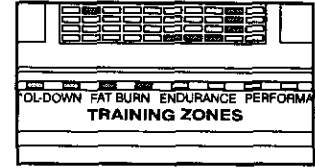

The left display—

The left display will show the elapsed time, your pedaling pace (measured in minutes per mile), and the distance

you have pedaled. The display will change from one number to the next every few seconds, as shown by the indicators around the display. Note: When a program is selected, the display will show the time remaining in the program and the time remaining in the current segment of the program instead of the elapsed time.

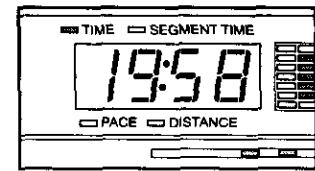

The right

display—The right display will show your pedaling speed, the approximate numbers of fat calories and

calories you have burned (see FAT BURNING on page 23), and the resistance level of the exercise cycle. The display will change from one number to the next every few seconds, as shown by the indicators. The display will also show your heart rate when you use the handgrip pulse sensor or the optional chest pulse sensor. Note: Each time the resistance of the exercise cycle changes, the display will show the resistance level.

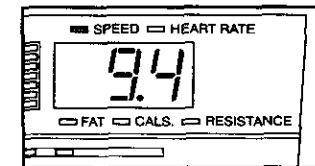

Note: The console can display speed and distance in either miles or kilometers. To find which unit of measurement is selected, you must select the console's user mode. Hold down the Program Select button for about three seconds. The letter "E" for English miles or the letter "M" for metric kilometers will appear in the left display. To change the unit of measurement, press the + button.

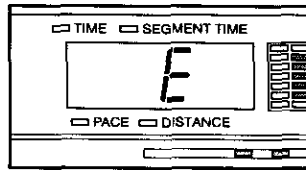

While the user mode is selected, press the Program Start button. The left display will then show the total number of hours that the exercise cycle has been used. Press the Program Start button again. The left display will then show the total number of miles pedaled. To exit the user mode, press the Program Select button again.

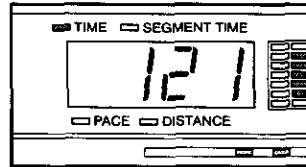

5 Measure your heart rate if desired.

Note: If you hold the handgrip pulse sensor and wear the optional chest pulse sensor at the same time, the console may not display your heart rate accurately.

If there are thin sheets of plastic on the metal contacts on the handgrip pulse sensor, peel off the plastic. To measure your heart rate, hold the contacts; your palms must be resting on the upper contacts, and your fingers must be touching the lower contacts. **Avoid moving your hands.**

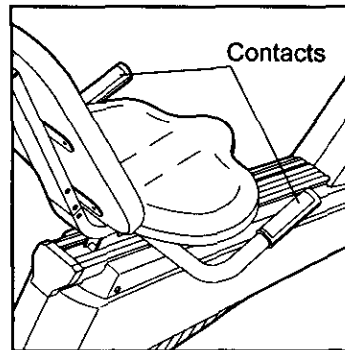

When your pulse is detected, the Heart Rate indicator above the right display will begin to flash, one or two dashes (--) will appear in the right display, and then your heart rate will be shown. For the most accurate heart rate reading, hold the contacts for at least 15 seconds.

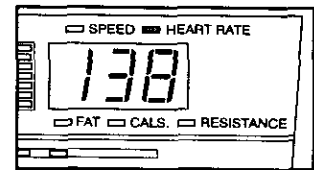

Note: If you continue to hold the pulse sensor, the right display will show your heart rate for up to 30 seconds. The display will then show your heart rate along with the other modes.

If your heart rate is not shown, make sure that your hands are positioned as described. Be careful not to move your hands excessively or to squeeze the metal contacts too tightly. For optimal performance, clean the metal contacts using a soft cloth; never use alcohol, abrasives, or chemicals.

6 Turn on the fan if desired.

To turn on the fan at low speed, press the Fan button. Pivot the fan to the desired angle. To turn on the fan at high speed, press the Fan button a second time. To turn off the fan, press the Fan button a third time.

7 When you are finished exercising, the console will automatically turn off.

If the pedals are not moved for several seconds, a tone will sound, the console will pause, and the left display will begin to flash.

If the pedals are not moved for about one minute, the console will turn off, but the displays will not be reset. If the pedals are not moved for about five minutes, the console will turn off and the displays will be reset.

HOW TO USE RESISTANCE AND PACE PROGRAMS

1 Begin pedaling to activate the console.

See step 1 on page 12.

2 Select one of the six resistance and pace programs.

When the power is turned on, the manual mode will be selected. To select a resistance and pace program, press the Program Select button repeatedly until a "P 1," "P 2," "P 3," "P 4," "P 5," or "P 6" appears in the right display.

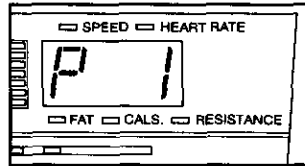

When a resistance and pace program is selected, the matrix will show the first seven pace settings for the program. The left display will show how long the program will last.

3 Press the Program Start button or begin pedaling to start the program.

Each program is divided into several time segments of different lengths. One pace setting and one resistance setting are programmed for each segment. (The same pace setting and/or resistance setting may be programmed for two or more consecutive segments.)

The pace setting for the first segment will be shown in the flashing Current Segment column of the matrix. (The resistance settings are not shown in the matrix.) The pace settings for the next several segments will be shown in the columns to the right.

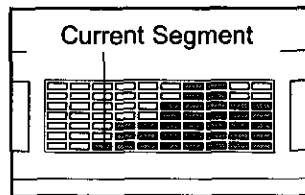

As you exercise, the Training Zone bar will help you to keep your pedaling pace near the pace setting for the current segment. The lit indicators

in the bar will show your actual pace. If an indicator to the right of the lit indicators is flashing (see drawing a), increase your pace. If an indicator to the left of any lit indicator is flashing (see drawing b), decrease your pace. When no indicator is flashing, your pace matches the pace setting for the current segment. **Important: The pace settings are intended only to provide motivation. Your actual pace may be slower than the current pace setting. Make sure to exercise at a pace that is comfortable for you.**

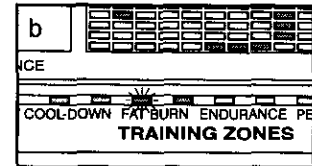
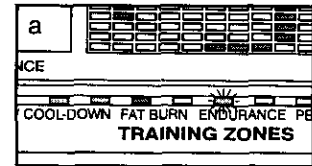

When only three seconds remain in the first segment of the program, both the Current Segment column and the column to the right will flash, a series of tones will sound, and *all pace settings will move one column to the left*. The pace setting for the second segment will then be shown in the flashing Current Segment column and the resistance of the exercise cycle will automatically change to the resistance setting for the second segment.

Note: If all of the indicators in the Current Segment column are lit after the pace settings have moved to the left, *the pace settings will move downward so that only the highest indicators appear in the matrix*.

The program will continue until the pace setting for the last segment is shown in the Current Segment column of the matrix and no time remains in the program.

Note: During the program, you can override the resistance setting for the current segment, if desired, with the Resistance buttons. However, when the next segment begins, the resistance may automatically change to the resistance setting for the next segment. If you stop pedaling for several seconds, a tone will sound and the program will pause. To restart the program, simply resume pedaling.

4 Monitor your progress with the two displays.

See step 4 on page 12.

5 Measure your heart rate if desired.

See step 5 on page 13.

6 Turn on the fan if desired.

See step 6 on page 13.

7 When the program is finished, the console will automatically turn off.

See step 7 on page 13.

HOW TO USE HEART RATE PROGRAMS

Each heart rate program helps you to keep your heart rate near a certain *percentage* of your *maximum heart rate* during your workout. (Your maximum heart rate is estimated by subtracting your age from 220. For example, if you are 30 years old, your maximum heart rate is 190.) Heart rate program 1 is designed to keep your heart rate between 50% and 80% of your maximum heart rate while you exercise; heart rate program 2 is designed to keep your heart rate between 50% and 85% of your maximum heart rate.

Follow the steps below to use a heart rate program.

1 Begin pedaling to activate the console.

See step 1 on page 12.

2 Select one of the heart rate programs.

When the power is turned on, the manual mode will be selected. To select a heart rate program, press the Program Select button repeatedly until an "H 1" or "H 2" appears in the right display.

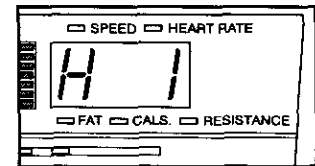

3 Enter your age.

When a heart rate program is selected, the word "AGE" and the current age setting will flash in the left display. You must enter your age to use a heart rate program. If you have already entered your age, press the Age Set Enter button and go to step 4. If you have not entered your age, press the + or - button repeatedly to enter your age, and then press the Age Set Enter button.

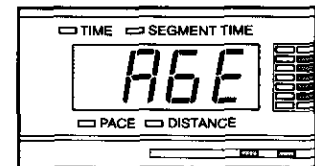

Once you have entered your age, it will be saved in memory.

4 Hold the handgrip pulse sensor.

To use a heart rate program, you must use the handgrip pulse sensor (see step 5 on page 13) or the optional chest pulse sensor. If you use the handgrip pulse sensor, it is not necessary to hold the handgrips continuously during the program. However, you should hold the handgrips frequently for the program to operate properly. **Each time you hold the handgrips, keep your hands on the metal contacts for at least 30 seconds.** Note: When you are not holding the handgrips, the letters "PLS" will appear in the right display instead of your heart rate.

5 Press the Program Start button or begin pedaling to start the program.

Each heart rate program consists of 20 one-minute segments. One resistance setting and one heart rate setting are programmed for each segment. (The same resistance setting and/or heart rate setting may be programmed for two or more consecutive segments.)

The resistance setting for the first segment will be shown in the flashing Current Segment column of the matrix. The resistance settings for the next several segments will be shown in the columns to the right.

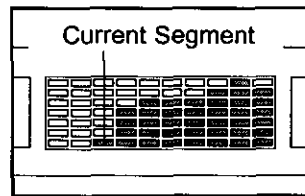

When only three seconds remain in the first segment of the program, both the Current Segment column and the column to the right will flash, a series of tones will sound, and *all resistance settings will move one column to the left*. The resistance setting for the second segment will then be shown in the flashing Current Segment column and the resistance of the exercise cycle will automatically adjust to the resistance setting for the second segment.

As you exercise, the Training Zone bar will help you to keep your heart rate near the heart rate setting for the current segment. The lit indicators in the bar will show your actual pace. When you hold the handgrip pulse sensor or wear the optional chest pulse sensor, the console will periodically compare

your heart rate to the heart rate setting for the current segment; if necessary, an indicator in the bar will then flash to prompt you to increase or decrease your pace to bring your heart rate closer to the current heart rate setting.

If an indicator to the *right* of the lit indicators is flashing (see drawing a), increase your pace. If an indicator to the *left* of any lit indicator is flashing (see drawing b), decrease your pace. When no indicator is flashing, your heart rate is near the current heart rate setting.

Important: The heart rate settings are intended only to provide motivation. Your actual heart rate may be slower than the current heart rate setting. Make sure to exercise at a pace that is comfortable for you.

The program will continue until the resistance setting for the last segment is shown in the Current Segment column of the matrix and no time remains in the program.

Note: During the program, you can manually override the resistance setting for the current segment, if desired, with the Resistance buttons. However, when the next segment begins, the exercise cycle will automatically adjust to the resistance setting for the next segment. If you stop pedaling for several seconds, a tone will sound and the program will pause. To restart the program, simply resume pedaling.

6 Monitor your progress with the two displays.

See step 4 on page 12.

7 Turn on the fan if desired.

See step 6 on page 13.

8 When the program is finished, the console will automatically turn off.

See step 7 on page 14.

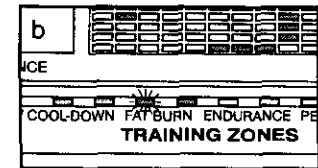
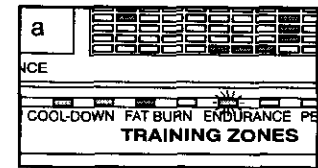

HOW TO CONNECT YOUR CD PLAYER, VCR, OR COMPUTER

To use iFIT.com CD's, the exercise cycle must be connected to your portable CD player, portable stereo, home stereo, or computer with CD player. See pages 17 and 18 for connecting instructions. To use iFIT.com videocassettes, the exercise cycle must be connected to your VCR. See page 19 for connecting instructions. To use iFIT.com programs directly from our Web site, the exercise cycle must be connected to your home computer. See page 18 for connecting instructions.

HOW TO CONNECT YOUR PORTABLE CD PLAYER

Note: If your CD player has separate LINE OUT and PHONES jacks, see instruction A below. If your CD player has only one jack, see instruction B.

- A. Plug one end of the audio cable into the jack beneath the console. Plug the other end of the cable into the LINE OUT jack on your CD player. Plug your headphones into the PHONES jack.

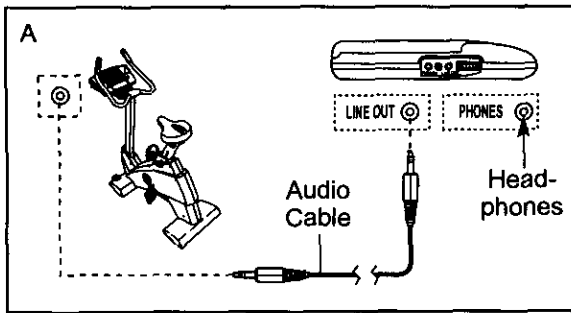

- B. Plug one end of the audio cable into the jack beneath the console. Plug the other end of the cable into a 1/8" Y-adapter (available at electronics stores). Plug the Y-adapter into the PHONES jack on your CD player. Plug your headphones into the other side of the Y-adapter.

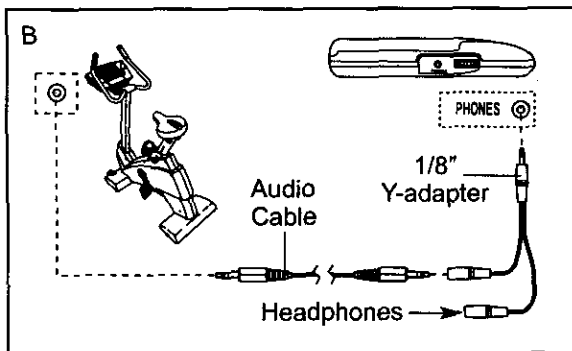

HOW TO CONNECT YOUR PORTABLE STEREO

Note: If your stereo has an RCA-type AUDIO OUT jack, see instruction A below. If your stereo has a 1/8" LINE OUT jack, see instruction B. If your stereo has only a PHONES jack, see instruction C.

- A. Plug one end of the audio cable into the jack beneath the console. Plug the other end of the cable into the adapter. Plug the adapter into an AUDIO OUT jack on your stereo.

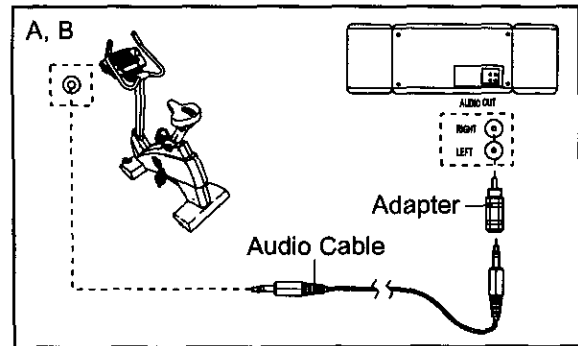

- B. Plug one end of the audio cable into the jack beneath the console. Plug the other end of the cable into the LINE OUT jack on your stereo. Do not use the adapter.

- C. Plug one end of the audio cable into the jack beneath the console. Plug the other end of the cable into a 1/8" Y-adapter (available at electronics stores). Plug the Y-adapter into the PHONES jack on your stereo. Plug your headphones into the other side of the Y-adapter.

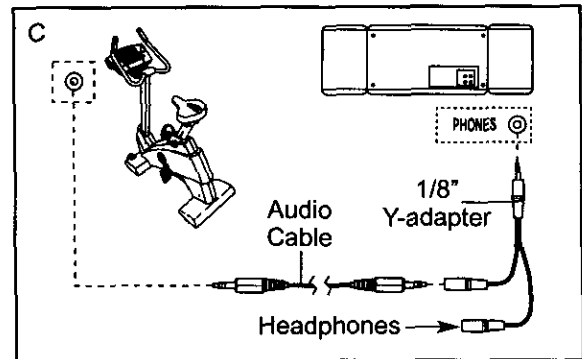

HOW TO CONNECT YOUR HOME STEREO

Note: If your stereo has an unused LINE OUT jack, see instruction A below. If the LINE OUT jack is being used, see instruction B.

- A. Plug one end of the audio cable into the jack beneath the console. Plug the other end of the cable into the adapter. Plug the adapter into the LINE OUT jack on your stereo.

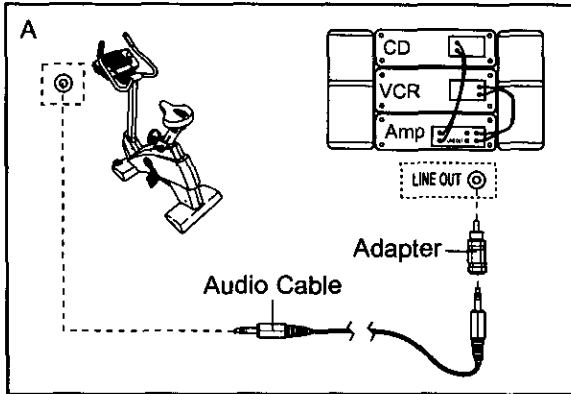

- B. Plug one end of the audio cable into the jack beneath the console. Plug the other end of the cable into the adapter. Plug the adapter into an RCA Y-adapter (available at electronics stores). Next, remove the wire that is currently plugged into the LINE OUT jack on your stereo and plug the wire into the unused side of the Y-adapter. Plug the Y-adapter into the LINE OUT jack on your stereo.

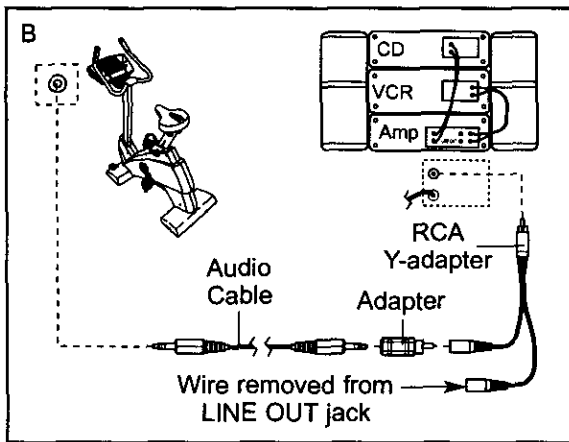

HOW TO CONNECT YOUR COMPUTER

Note: If your computer has a 1/8" LINE OUT jack, see instruction A. If your computer has only a PHONES jack, see instruction B.

- A. Plug one end of the audio cable into the jack beneath the console. Plug the other end of the cable into the LINE OUT jack on your computer.

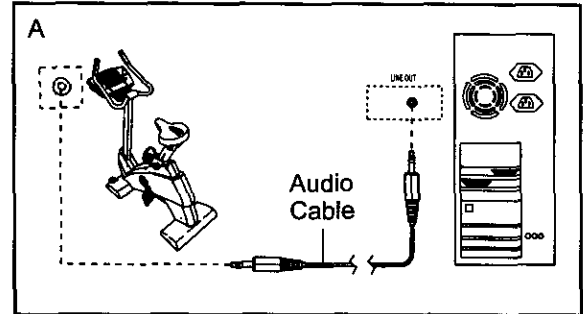

- B. Plug one end of the audio cable into the jack beneath the console. Plug the other end of the cable into a 1/8" Y-adapter (available at electronics stores). Plug the Y-adapter into the PHONES jack on your computer. Plug your headphones or speakers into the other side of the Y-adapter.

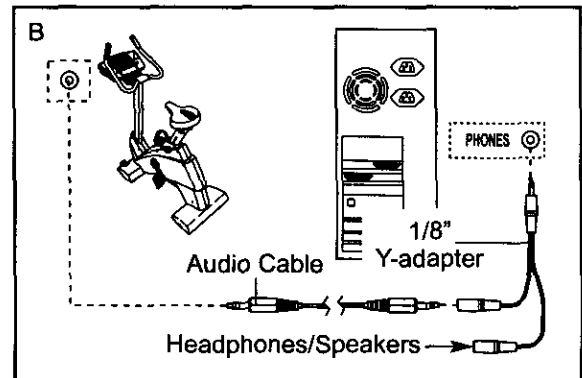

HOW TO CONNECT YOUR VCR

Note: If your VCR has an unused AUDIO OUT jack, see instruction A below. If the AUDIO OUT jack is being used, see instruction B. If you have a TV with a built-in VCR, see instruction B. If your VCR is connected to your home stereo, see HOW TO CONNECT YOUR HOME STEREO on page 18.

- A. Plug one end of the audio cable into the jack beneath the console. Plug the other end of the cable into the adapter. Plug the adapter into the AUDIO OUT jack on your VCR.

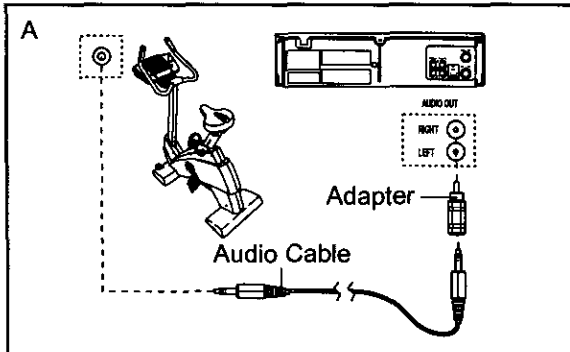

- B. Plug one end of the audio cable into the jack beneath the console. Plug the other end of the cable into the adapter. Plug the adapter into an RCA Y-adapter (available at electronics stores). Next, remove the wire that is currently plugged into the AUDIO OUT jack on your VCR and plug the wire into the unused side of the Y-adapter. Plug the Y-adapter into the AUDIO OUT jack on your VCR.

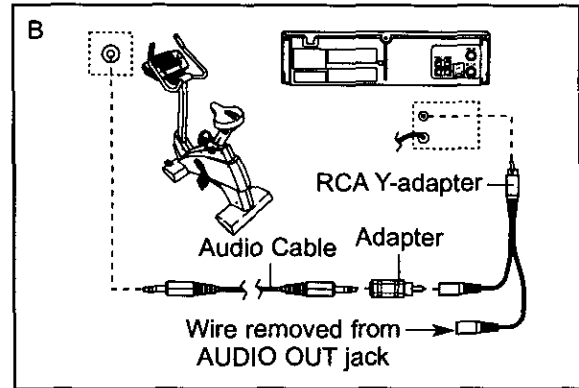

HOW TO USE iFIT.COM CD AND VIDEO PROGRAMS

To use iFIT.com CD's or videocassettes, the exercise cycle must be connected to your portable CD player, portable stereo, home stereo, computer with CD player, or VCR. See HOW TO CONNECT YOUR CD PLAYER, VCR, OR COMPUTER on page 17. To purchase iFIT.com CD's and videocassettes, call toll-free 1-800-735-0768.

Follow the steps below to use an iFIT.com CD or video program.

1 Begin pedaling to activate the console.

See step 1 on page 12.

2 Select the iFIT.com mode.

When the console is turned on, the manual mode will be selected. To select the iFIT.com mode, press the iFIT.com button.

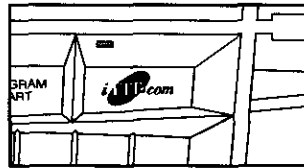

The indicator above the button will light.

3 Insert the iFIT.com CD or videocassette.

If you are using an iFIT.com CD, insert the CD into your CD player. If you are using an iFIT.com videocassette, insert the videocassette into your VCR.

4 Press the play button on your CD player or VCR.

A moment after the play button is pressed, your personal trainer will begin guiding you through

your workout. Simply follow your personal trainer's instructions.

The program will function in almost the same way as a resistance and pace program (see step 3 on page 14). However, an electronic "chirping" sound will alert you when the resistance setting and/or the pace setting is about to change.

Note: If the resistance of the exercise cycle and/or the pace setting does not change when a "chirp" is heard:

- Make sure that the indicator above the iFIT.com button is lit.
- Adjust the volume of your CD player or VCR. If the volume is too high or too low, the console may not detect the program signals.
- Make sure that the audio cable is properly connected and that it is fully plugged in.

5 Monitor your progress with the two displays.

See step 4 on page 12.

6 Measure your heart rate if desired.

See step 5 on page 13.

7 Turn on the fan if desired.

See step 6 on page 13.

8 When the program is finished, the console will automatically turn off.

See step 7 on page 13.

HOW TO USE PROGRAMS DIRECTLY FROM OUR WEB SITE

Our Web site at www.iFIT.com allows you to play iFIT.com audio and video programs directly from the internet. To use programs from our Web site, the exercise cycle must be connected to your home computer. See HOW TO CONNECT YOUR COMPUTER on page 18. In addition, you must have an internet connection and an internet service provider. A list of specific system requirements will be found on our Web site.

Follow the steps below to use a program from our Web site.

1 Begin pedaling to activate the console.

See step 1 on page 12.

2 Select the iFIT.com mode.

When the console is turned on, the manual mode will be selected. To select the iFIT.com mode, press the iFIT.com button.



The indicator above the button will light.

3 Go to your computer and start an internet connection.

4 Start your Web browser, if necessary, and go to our Web site at www.iFIT.com.

5 Follow the desired links on our Web site to select a program.

Read and follow the on-line instructions for using a program.

6 Follow the on-line instructions to start the program.

When you start the program, an on-screen countdown will begin.

7 Return to the exercise cycle and begin pedaling.

When the on-screen countdown ends, the program will begin. The program will function in almost the same way as a resistance and pace program (see step 3 on page 14). However, an electronic "chirping" sound will alert you when the resistance setting and/or the pace setting is about to change.

8 Monitor your progress with the two displays.

See step 4 on page 12.

9 Measure your heart rate if desired.

See step 5 on page 13.

10 Turn on the fan if desired.

See step 6 on page 13.

11 When you are finished exercising, the console will automatically turn off.

See step 7 on page 13.

THE OPTIONAL CHEST PULSE SENSOR

The optional chest pulse sensor provides hands-free operation and continuously monitors your heart rate during your workouts. To purchase the optional chest pulse sensor, call toll-free 1-800-734-2377.

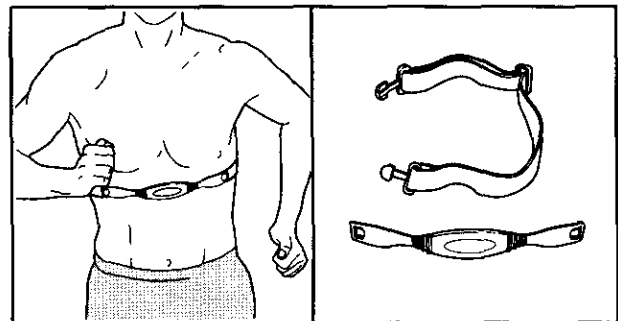

MAINTENANCE AND TROUBLESHOOTING

Inspect and properly tighten all parts of the exercise cycle regularly. To clean the exercise cycle, use a soft, damp cloth. Keep liquids away from the console and keep the console out of direct sunlight.

HOW TO ADJUST THE REED SWITCH

If the console does not display correct feedback, the reed switch should be adjusted. To adjust the reed switch, the right side shield must first be removed. Remove the indicated M4 x 25mm Screws (65) from the Left Side Shield (26).

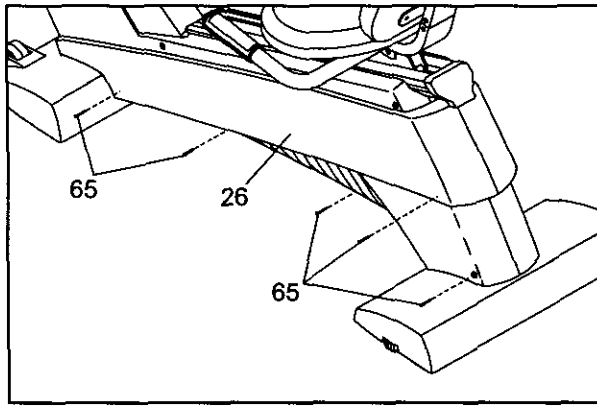

Next, remove the indicated M5 x 25mm Screw (93) and M4 x 16mm Screws (57) from the Right Side Shield (27). Using an adjustable wrench, turn the Right Pedal (21) counterclockwise and remove it. Turn the Right Crank Arm (23) so that it is pointing toward the front of the exercise cycle, and then slide off the Right Side Shield.

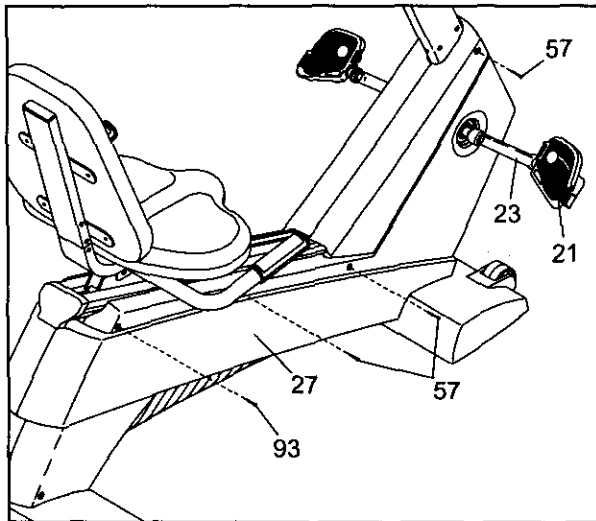

Locate the Reed Switch (46). Turn the Right Crank Arm (23) until the Magnet (30) is aligned with the Reed Switch. Loosen, but do not remove, the indicated M4 x 16mm Screw (57). Slide the Reed Switch slightly closer to or away from the Magnet. Then, retighten the Screw. Turn the Right Crank Arm for a moment. Repeat until the console displays correct feedback. When the Reed Switch is correctly adjusted, reattach the right side shield and the right pedal.

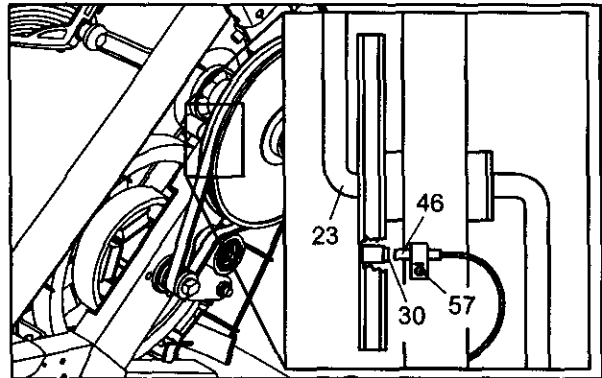

HOW TO ADJUST THE DRIVE BELT

If you can feel the pedals slip while you are pedaling, even when the resistance is adjusted to the highest level, the Drive Belt (47) may need to be adjusted. To adjust the Drive Belt, you must first remove the right side shield. Refer to HOW TO ADJUST THE REED SWITCH at the left and remove the right side shield.

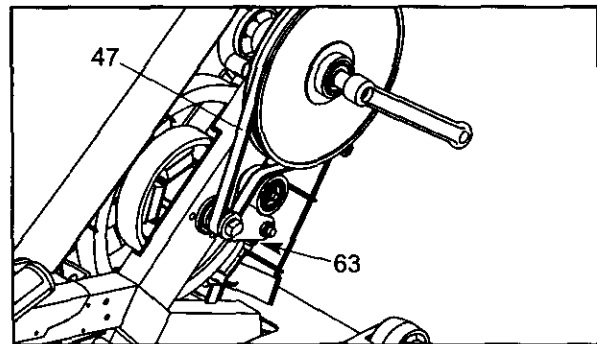

Next, turn the indicated M10 Nylon Locknut (63) until the Drive Belt (47) is properly tightened. Then, reattach the right side shield.

PULSE SENSOR TROUBLESHOOTING

If the handgrip pulse sensor does not function properly, refer to step 5 on page 13.

EXERCISE GUIDELINES



WARNING:

- Before beginning this or any exercise program, consult your physician. This is especially important for individuals over the age of 35 or individuals with pre-existing health problems.
- The pulse sensor is not a medical device. Various factors may affect the accuracy of heart rate readings. The pulse sensor is intended only as an exercise aid in determining heart rate trends in general.

The following guidelines will help you to plan your exercise program. Remember that proper nutrition and adequate rest are essential for successful results.

EXERCISE INTENSITY

Whether your goal is to burn fat or to strengthen your cardiovascular system, the key to achieving the desired results is to exercise with the proper intensity. The proper intensity level can be found by using your heart rate as a guide. The chart below shows recommended heart rates for fat burning, maximum fat burning, and cardiovascular (aerobic) exercise.

| | | | | | | | |
|-----|-----|-----|-----|-----|-----|-----|---|
| 165 | 155 | 145 | 140 | 130 | 125 | 115 |  |
| 145 | 138 | 130 | 125 | 118 | 110 | 103 |  |
| 125 | 120 | 115 | 110 | 105 | 95 | 90 |  |
| 20 | 30 | 40 | 50 | 60 | 70 | 80 | |

To find the proper heart rate for you, first find your age at the bottom of the chart (ages are rounded off to the nearest ten years). Next, find the three numbers above your age; the three numbers are your "training zone." The lowest number is the recommended heart rate for fat burning; the middle number is the recommended heart rate for maximum fat burning; and the highest number is the heart rate for aerobic exercise.

Fat Burning

To burn fat effectively, you must exercise at a relatively low intensity level for a sustained period of time. During the first few minutes of exercise, your body uses easily accessible *carbohydrate* calories for energy. Only after the first few minutes of exercise does your body begin to use stored *fat* calories for energy. If your goal is to burn fat, adjust the intensity of your exercise until your heart rate is near the lowest number or the middle number in your training zone as you exercise.

Aerobic Exercise

If your goal is to strengthen your cardiovascular system, your exercise must be "aerobic." Aerobic exercise is activity that requires large amounts of oxygen for prolonged periods of time. This increases the demand on the heart to pump blood to the muscles, and on the lungs to oxygenate the blood. For aerobic exercise, adjust the intensity of your exercise until your heart rate is near the highest number in your training zone.

WORKOUT GUIDELINES

Each workout should include the following three parts:

A warm-up, consisting of 5 to 10 minutes of stretching and light exercise. A proper warm-up increases your body temperature, heart rate, and circulation in preparation for exercise.

Training zone exercise, consisting of 20 to 30 minutes of exercising with your heart rate in your training zone. (During the first few weeks of your exercise program, do not keep your heart rate in your training zone for longer than 20 minutes.)

A cool-down, with 5 to 10 minutes of stretching. This will increase the flexibility of your muscles and will help to prevent post-exercise problems.

EXERCISE FREQUENCY

To maintain or improve your condition, plan three workouts each week, with at least one day of rest between workouts. After a few months of regular exercise, you may complete up to five workouts each week, if desired. The key to success is make exercise a regular and enjoyable part of your everyday life.

SUGGESTED STRETCHES

The correct form for several basic stretches is shown at the right. Move slowly as you stretch—never bounce.

1. Toe Touch Stretch

Stand with your knees bent slightly and slowly bend forward from your hips. Allow your back and shoulders to relax as you reach down toward your toes as far as possible. Hold for 15 counts, then relax. Repeat 3 times. Stretches: Hamstrings, back of knees and back.

2. Hamstring Stretch

Sit with one leg extended. Bring the sole of the opposite foot toward you and rest it against the inner thigh of your extended leg. Reach toward your toes as far as possible. Hold for 15 counts, then relax. Repeat 3 times for each leg. Stretches: Hamstrings, lower back and groin.

3. Calf/Achilles Stretch

With one leg in front of the other, reach forward and place your hands against a wall. Keep your back leg straight and your back foot flat on the floor. Bend your front leg, lean forward and move your hips toward the wall. Hold for 15 counts, then relax. Repeat 3 times for each leg. To cause further stretching of the achilles tendons, bend your back leg as well. Stretches: Calves, achilles tendons and ankles.

4. Quadriceps Stretch

With one hand against a wall for balance, reach back and grasp one foot with your other hand. Bring your heel as close to your buttocks as possible. Hold for 15 counts, then relax. Repeat 3 times for each leg. Stretches: Quadriceps and hip muscles.

5. Inner Thigh Stretch

Sit with the soles of your feet together and your knees outward. Pull your feet toward your groin area as far as possible. Hold for 15 counts, then relax. Repeat 3 times. Stretches: Quadriceps and hip muscles.

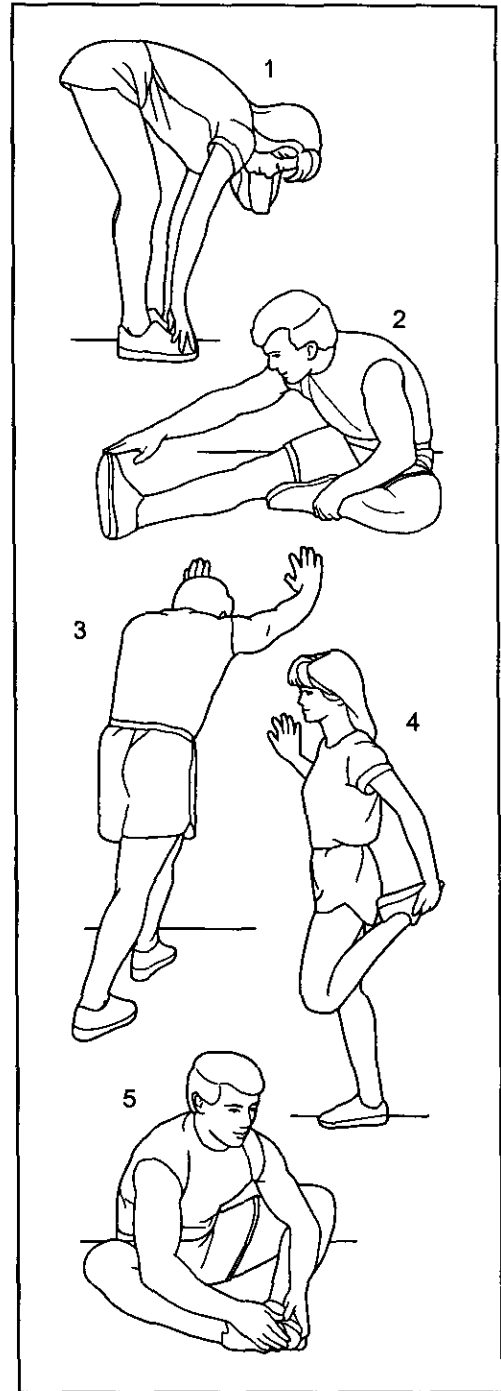

PART LIST—Model No. NTC69020

R0303A

| Key No. | Qty. | Description | Key No. | Qty. | Description |
|---------|------|------------------------|---------|------|--------------------------|
| 1 | 1 | Frame | 50 | 2 | Flange Screw |
| 2 | 1 | Upright | 51 | 12 | Stand-off |
| 3 | 1 | Pulse Wire | 52 | 1 | Seat Carriage Endcap |
| 4 | 1 | Console | 53 | 2 | Set Bolt |
| 5 | 1 | Seat Rail | 54 | 8 | M8 x 40mm Button Screw |
| 6 | 2 | Pulse Sensor | 55 | 12 | M8 Split Washer |
| 7 | 1 | Seat Frame | 56 | 8 | M4 x 38mm Screw |
| 8 | 1 | Seat Rail Endcap | 57 | 20 | M4 x 16mm Screw |
| 9 | 1 | Seat | 58 | 4 | Carriage Bushing |
| 10 | 1 | Seat Knob | 59 | 2 | M6 x 50mm Bolt |
| 11 | 1 | Seat Carriage | 60 | 4 | M8 Washer |
| 12 | 1 | Seat Frame Endcap | 61 | 1 | M10 Washer |
| 13 | 1 | Front Stabilizer Cover | 62 | 1 | Backrest |
| 14 | 1 | Rear Stabilizer Cover | 63 | 5 | M10 Nylon Locknut |
| 15 | 1 | Front Stabilizer | 64 | 4 | M5 Nylon Locknut |
| 16 | 1 | Rear Stabilizer | 65 | 6 | M4 x 25mm Screw |
| 17 | 2 | Wheel | 66 | 1 | Backrest Frame Endcap |
| 18 | 1 | Right Pedal Strap | 67 | 1 | Idler Bolt |
| 19 | 4 | Leveling Foot | 68 | 4 | M8 x 14mm Tapered Bolt |
| 20 | 1 | Generator | 69 | 2 | M5 Nut |
| 21 | 1 | Right Pedal | 70 | 1 | Frame RJ14 Outlet |
| 22 | 1 | Left Pedal | 71 | 6 | M5 Washer |
| 23 | 1 | Right Crank Arm | 72 | 1 | Frame RJ14 Bracket |
| 24 | 1 | Left Crank Arm | 73 | 1 | Carriage RJ14 Bracket |
| 25 | 1 | Left Pedal Strap | 74 | 4 | M5 x 16mm Bolt |
| 26 | 1 | Left Side Shield | 75 | 6 | M5 x 16mm Screw |
| 27 | 1 | Right Side Shield | 76 | 1 | M10 x 43mm Bolt |
| 28 | 3 | Snap Ring | 77 | 3 | M8 x 35mm Screw |
| 29 | 1 | Pulley | 78 | 2 | M10 x 110mm Button Screw |
| 30 | 1 | Magnet | 79 | 4 | M8 x 25mm Button Screw |
| 31 | 1 | Crank | 80 | 8 | 1/4" x 16mm Button Screw |
| 32 | 3 | Pulley Spacer | 81 | 1 | Carriage RJ14 Outlet |
| 33 | 5 | Crank Bearing | 82 | 2 | M10 x 52mm Button Bolt |
| 34 | 1 | Flywheel | 83 | 7 | M6 Nylon Locknut |
| 35 | 1 | "C" Magnet | 84 | 2 | Bumper |
| 36 | 1 | Resistance Cable | 85 | 1 | "J" Bolt Bushing |
| 37 | 1 | Spring | 86 | 1 | RJ14 Cable |
| 38 | 1 | Resistance Motor | 87 | 1 | M6 x 52mm Bolt |
| 39 | 1 | Idler Arm | 88 | 2 | M10 Split Washer |
| 40 | 1 | Control Board | 89 | 1 | M8 Nylon Locknut |
| 41 | 1 | Control Bracket | 90 | 3 | M8 Nylon Jam Nut |
| 42 | 1 | Backrest Frame | 91 | 1 | M6 x 45mm Bolt |
| 43 | 1 | Wire Harness | 92 | 1 | M10 Flange Nut |
| 44 | 1 | Flywheel Bracket | 93 | 2 | M5 x 25mm Screw |
| 45 | 1 | Clamp | 94 | 2 | M4 Washer |
| 46 | 1 | Reed Switch/Wire | 95 | 1 | M4 Push Nut |
| 47 | 1 | Drive Belt | # | 3 | Allen Wrench |
| 48 | 1 | Flywheel Axle | # | 1 | User's Manual |
| 49 | 1 | M10 x 82mm Bolt | | | |

Note: "#" indicates a non-illustrated part. Specifications are subject to change without notice. See the back cover of this manual for information about ordering replacement parts.

EXPLODED DRAWING—Model No. NTC69020

R0303A

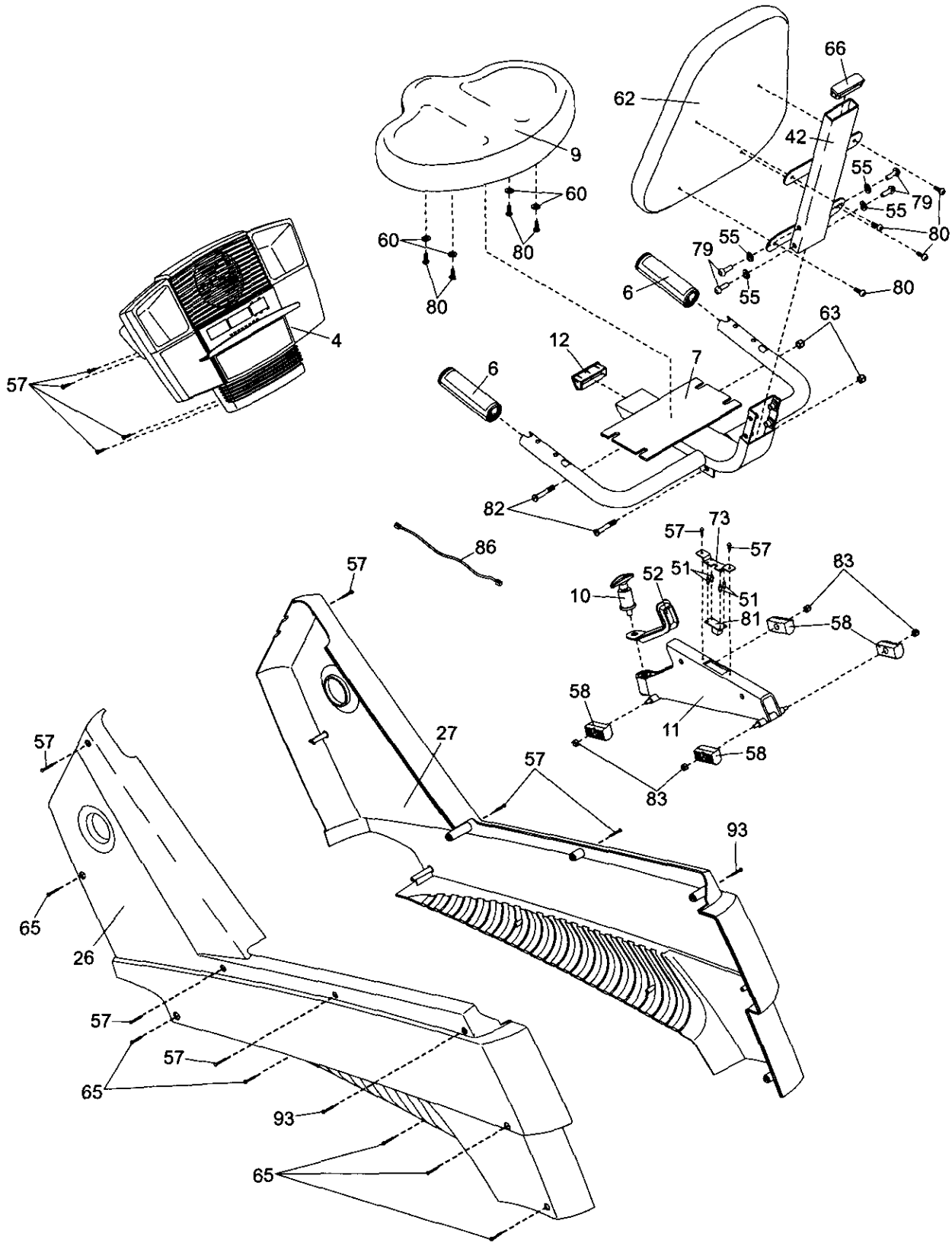

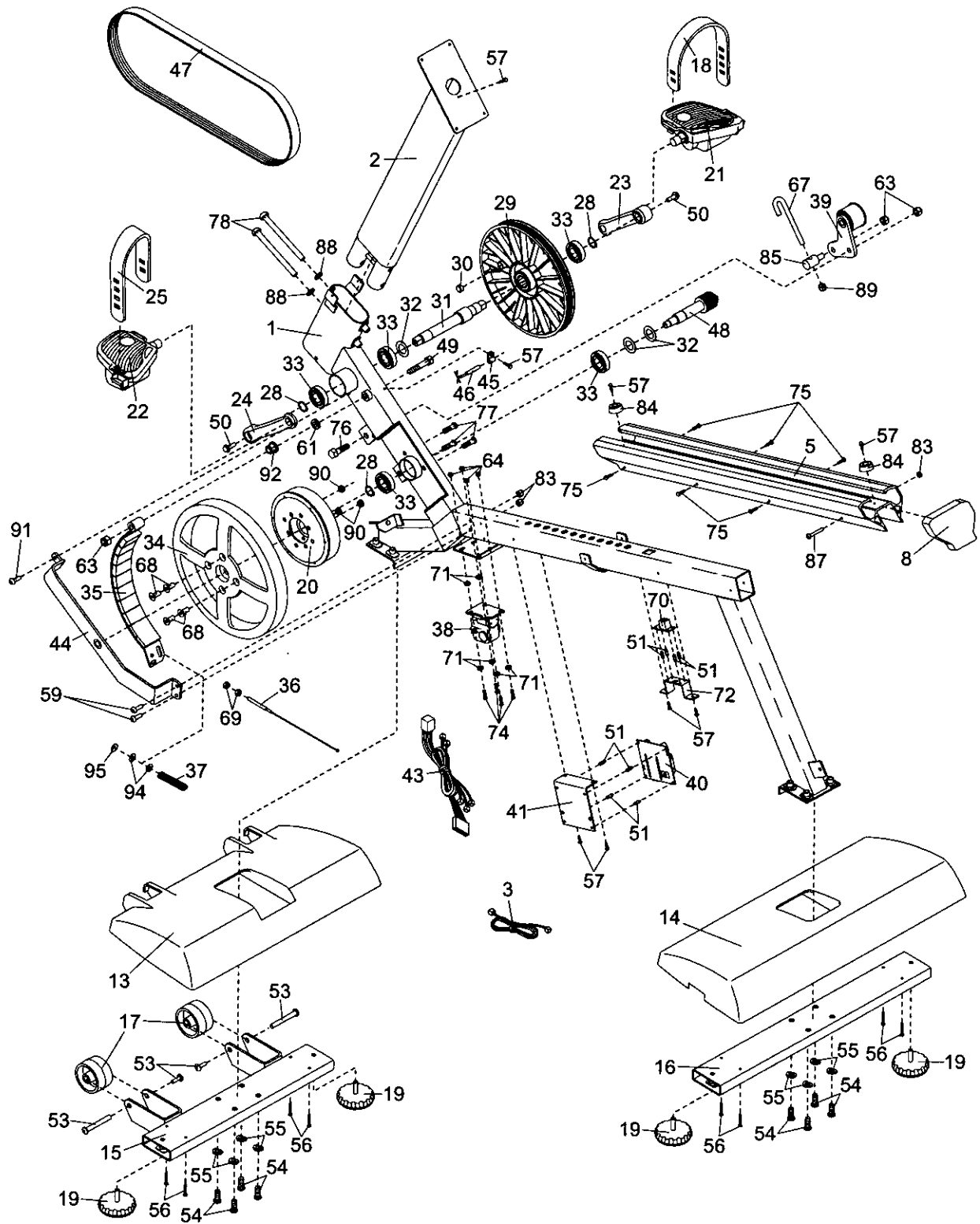

HOW TO ORDER REPLACEMENT PARTS

To order replacement parts, simply call our Customer Service Department toll-free at 1-888-825-2588, Monday through Friday, 6 a.m. until 6 p.m. Mountain Time (excluding holidays). To help us assist you, please be prepared to give the following information when calling:

- the MODEL NUMBER of the product (NTC69020)
- the NAME of the product (NordicTrack® SL 720 exercise cycle)
- the SERIAL NUMBER of the product (see the front cover of this manual)
- the KEY NUMBER and DESCRIPTION of the part(s) (see pages 25, 26, and 27)

LIMITED WARRANTY

WHAT IS COVERED—The entire NordicTrack® SL 720 exercise cycle ("Product") is warranted to be free of all defects in material and workmanship.

WHO IS COVERED—The original purchaser or any person receiving the Product as a gift from the original purchaser.

HOW LONG IS IT COVERED—ICON Health & Fitness, Inc. ("ICON"), warrants the product for one year after the date of purchase. Labor is covered for one year.

WHAT WE DO TO CORRECT COVERED DEFECTS—We will ship to you, without charge, any replacement part or component, providing the repairs are authorized by ICON first and are performed by an ICON trained and authorized service provider, or, at our option, we will replace the Product.

WHAT IS NOT COVERED—Any failures or damage caused by unauthorized service, misuse, accident, negligence, improper assembly or installation, alterations, modifications without our written authorization or by failure on your part to use, operate, and maintain as set out in your User's Manual ("Manual").

WHAT YOU MUST DO—Always retain proof of purchase, such as your bill of sale; store, operate, and maintain the Product as specified in the Manual; notify our Customer Service Department of any defect within 10 days after discovery of the defect; as instructed, return any defected part for replacement or, if necessary, the entire product, for repair.

USER'S MANUAL—It is VERY IMPORTANT THAT YOU READ THE MANUAL before operating the Product. Remember to do the periodic maintenance requirements specified in the Manual to assure proper operation and your continued satisfaction.

HOW TO GET PARTS AND SERVICE—Simply call our Customer Service Department at 1-888-825-2588 and tell them your name and address and the serial number of your Product. They will tell you how to get a part replaced, or if necessary, arrange for service where your Product is located or advise you how to ship the Product for service. Before shipping, always obtain a Return Authorization Number (RA No.) from our Customer Service Department; securely pack your Product (save the original shipping carton if possible); put the RA No. on the outside of the carton and insure the product. Include a letter explaining the product or problem and a copy of your proof of purchase if you believe the service is covered by warranty.

ICON is not responsible or liable for indirect, special or consequential damages arising out of or in connection with the use or performance of the product or damages with respect to any economic loss, loss of property, loss of revenues or profits, loss of enjoyment or use, costs of removal, installation or other consequential damages of whatsoever nature. Some states do not allow the exclusion or limitation of incidental or consequential damages. Accordingly, the above limitation may not apply to you.

The warranty extended hereunder is in lieu of any and all other warranties and any implied warranties of merchantability or fitness for a particular purpose is limited in its scope and duration to the terms set forth herein. Some states do not allow limitations on how long an implied warranty lasts. Accordingly, the above limitation may not apply to you.

No one is authorized to change, modify or extend the terms of this limited warranty. This warranty gives you specific legal rights and you may have other rights which vary from state to state.

ICON HEALTH & FITNESS, INC., 1500 S. 1000 W., LOGAN, UT 84321-9813