

Omnivision VHS

Panasonic®

Combination VCR Operating Instructions

Model No. PV-C2062/PV-C2542



- Initial Setup and Connection Procedures are on pages 8 and 9.



As an ENERGY STAR® Partner,
Matsushita Electric Corporation of America has
determined that this product or product model meets
the ENERGY STAR® guidelines for energy efficiency.



Please read these instructions carefully before attempting to connect, operate, or adjust this product. Please save this manual. Spanish Quick Use Guide is included. (Guía para rápida consulta en español está incluida.)

For assistance, please call : 1-800-211-PANA(7262) or send e-mail to : consumerproducts@panasonic.com

Initial Setup

Basic Operation

TV Operation

Timer Operation Advanced Operation For Your Information

LSQ10582A

Important Safeguards and Precautions

READ AND RETAIN ALL SAFETY AND OPERATING INSTRUCTIONS. HEED ALL WARNINGS IN THE MANUAL AND ON UNIT

INSTALLATION

1 POWER SOURCE CAUTION

Operate only from power source indicated on unit or in this manual. If uncertain, have your Electric Utility Service Company or Video Products Dealer verify your home power source.

2 POWER CORD PLUG

For safety, this unit has a polarized type plug (one wide blade), or a three-wire grounding type plug. Always hold the plug firmly and make sure your hands are dry when plugging in or unplugging the AC power cord. Regularly remove dust, dirt, etc. on the plug.

POLARIZED PLUG CAUTION:

The plug fits into outlet one way. If it cannot be fully inserted, try reversing it. If it still will not fit, have an electrician install the proper wall outlet. Do not tamper with the plug.

GROUNDING PLUG CAUTION:

The plug requires a three-hole grounding outlet. If necessary, have an electrician install the proper outlet. Do not tamper with the plug.

3 POWER CORD

To avoid unit malfunction, and to protect against electrical shock, fire or personal injury:

- Keep power cord away from heating appliances and walking traffic. Do not rest heavy objects on, or roll such objects over the power cord.
- Do not tamper with the cord in any way.
- An extension cord should have the same type plug (polarized or grounding) and must be securely connected.
- Overloaded wall outlets or extension cords are a fire hazard.
- Frayed cords, damaged plugs, and damaged or cracked wire insulation are hazardous and should be replaced by a qualified electrician.

4 DO NOT BLOCK VENTILATION HOLES

Ventilation openings in the cabinet release heat generated during operation. If blocked, heat build-up may result in a fire hazard or heat damage to cassettes.

For your protection:

- Never cover ventilation slots while unit is ON, or operate unit while placed on a bed, sofa, rug, or other soft surface.
- Avoid built-in installation, such as a book case or rack, unless properly ventilated.

5 AVOID EXTREMELY HOT LOCATIONS OR SUDDEN TEMPERATURE CHANGES

Do not place unit over or near a heater or regulator, in direct sunlight, etc. If unit is suddenly moved from a cold place to a warm place, moisture may condense in unit and on the tape causing damage.

6 TO AVOID PERSONAL INJURY

- Never place unit on support or stand that is not firm, level, and adequately strong. The unit could fall causing serious injury to a child or adult and damage to the unit.
- Move any appliance and cart combination with care. Quick stops, excessive force, and uneven surfaces may cause objects to overturn.
- Carefully follow all operating instructions.



OUTDOOR ANTENNA INSTALLATION

1 SAFE ANTENNA AND CABLE CONNECTION

An outside antenna or cable system must be properly grounded to provide some protection against built up static charges and voltage. Section 810 of the National Electrical Code, ANSI/NFPA 70 (in Canada, part 1 of the Canadian Electrical Code) provides information regarding proper

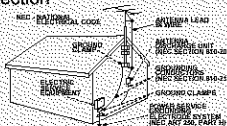

grounding of the mast and supporting structure, grounding of the lead-in wire to an antenna discharge unit, size of grounding conductors, location of antenna discharge unit, connection to grounding electrodes, and requirements for the grounding electrode.

2 KEEP ANTENNA CLEAR OF HIGH VOLTAGE POWER LINES OR CIRCUITS

Locate an outside antenna system well away from power lines and electric light or power circuits so it will never touch these power sources should it ever fall. When installing antenna, absolutely never touch power lines, circuits or other power sources as this could be fatal.

USING THE UNIT

Before unit is brought out of storage or moved to a new location, refer again to the INSTALLATION section of these safeguards.

1 KEEP UNIT WELL AWAY FROM WATER OR

MOISTURE, such as vases, sinks, tubs, etc.

2 IF EXPOSED TO RAIN, MOISTURE, OR STRONG

IMPACT, unplug unit and have it inspected by a qualified service technician before use.

3 ELECTRICAL STORMS

During a lightning storm, or before leaving unit unused for extended periods of time, disconnect all equipment from the power source as well as the antenna and cable system.

4 WHEN UNIT IS PLUGGED IN

- **DO NOT OPERATE IF**
 - liquid has spilled into unit.
 - unit was dropped or otherwise damaged.
 - unit emits smoke, malodors, or noises.Immediately unplug unit, and have it inspected by a service technician to avoid potential fire and shock hazards.
- Never drop or push any object through openings in unit. Touching internal parts may cause electric shock or fire hazard.
- Keep magnetic objects, such as speakers, away from unit to avoid electrical interference.

5 USING ACCESSORIES

Use only accessories recommended by the manufacturer to avoid risk of fire, shock, or other hazards.

6 CLEANING UNIT

Unplug unit. Use a clean, dry, chemically untreated cloth to gently remove dust or debris. **DO NOT USE** cleaning fluids, aerosols, or forced air that could over-spray, or seep into unit and cause electrical shock. Any substance, such as wax, adhesive tape, etc. may mar the cabinet surface. Exposure to greasy, humid, or dusty areas may adversely affect internal parts.

SERVICE

1 DO NOT SERVICE PRODUCT YOURSELF

If, after carefully following detailed operating instructions, the unit does not operate properly, do not attempt to open or remove covers, or make any adjustments not described in the manual. Unplug unit and contact a qualified service technician.

2 REPLACEMENT OF PARTS

Make sure the service technician uses only parts specified by the manufacturer, or have equal safety characteristics as original parts. The use of unauthorized substitutes may result in fire, electric shock, or other hazards.

3 SAFETY CHECK AFTER SERVICING

After unit is serviced or repaired, request that a thorough safety check be done as described in the manufacturer's service literature to insure video unit is in safe operating condition.

Safety Precautions/Mesures de sécurité

Warning : To prevent fire or shock hazard, do not expose this equipment to rain or moisture.

Caution : To prevent electric shock, match wide blade of plug to wide slot, fully insert.

Avertissement : Afin de prévenir tout risque d'incendie ou de chocs électriques, ne pas exposer cet appareil à la pluie ou à une humidité excessive.

Attention : Pour éviter les chocs électriques, introduire la lame la plus large de la fiche dans la borne correspondante de la prise et pousser jusqu'au fond.

This video recorder, equipped with the HQ (High Quality) System, is compatible with existing VHS equipment. Only use those tapes with the **VHS** mark. It is recommended that only cassette tapes that have been tested and inspected for use in 2, 4, 6, and 8 hour VCR machines be used. This television receiver provides display of television closed captioning in accordance with §15.119 of the FCC rules.

FCC WARNING : Any unauthorized changes or modifications to this equipment would void the user's authority to operate.

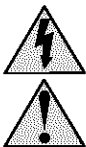

This symbol warns the user that uninsulated voltage within the unit may have sufficient magnitude to cause electric shock. Therefore, it is dangerous to make any kind of contact with any inside part of this unit.

This symbol alerts the user that important literature concerning the operation and maintenance of this unit has been included. Therefore, it should be read carefully in order to avoid any problems.

This product utilizes both a Cathode Ray Tube (CRT) and other components that contain lead. Disposal of these materials may be regulated in your community due to environmental considerations. For disposal or recycling information please contact your local authorities, or the Electronics Industries Alliance: <<http://www.eiae.org>>

Congratulations

on your purchase of one of the most sophisticated and reliable products on the market today. Used properly, it will bring you and your family years of enjoyment. Please fill in the information below. The serial number is on the tag located on the back of your unit.

Date of Purchase _____
 Dealer Purchased From _____
 Dealer Address _____
 Dealer Phone No. _____
 Model No. _____
 Serial No. _____

Accessories

- Remote Control
 LSSQ0319 (PV-C2062)
 LSSQ0341 (PV-C2542)

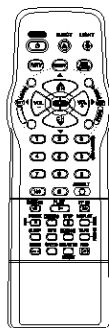

Model PV-C2062 remote shown.

- Batteries
 2 "AA"

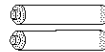

To order accessories, call toll free 1-800-332-5368.

Loading the Batteries

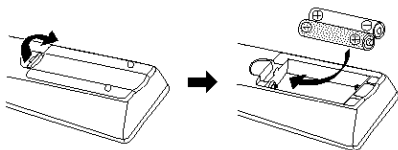

Battery replacement caution

- Do not mix old and new batteries.
- Do not mix alkaline with manganese batteries.

Prevent Accidental Tape Erasure

Break off the tab to prevent recording.

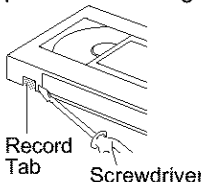

To record again.



Head Cleaning

Playing older or damaged tapes may eventually cause video heads to become clogged.

Head Clog Sensor

During playback this screen appears if clogging is detected. To remove screen, press PLAY on the remote or unit.

VIDEO HEADS MAY
NEED CLEANING
PLEASE INSERT HEAD
CLEANING CASSETTE
OR REFER TO MANUAL

END: PLAY KEY

- Use "dry" type head cleaning cassette only. (Part No. NV-TCL30PT is recommended.)
- Follow cleaning tape directions carefully. Excessive use of head cleaning tape can shorten the video head life.
- If head clog symptoms persist, contact your nearest Factory Service Center or authorized Service Center. (See Page 36.)

Features for a Quality Picture

Digital Auto Tracking

Continuously analyzes the signal and adjusts for optimum picture quality.

Manual Tracking Control (to reduce picture noise)

Use during Playback and Slow Motion mode to reduce picture noise. Press the 3 or 6 number key on the remote control or CH ▲▼ on the unit until the picture clears up. To return to Auto Tracking, press POWER off, then on again a few seconds later.

PanaBlack™ Picture Tube (PV-C2542 only)

This unit uses a PanaBlack™ picture tube for better color reproduction and picture contrast.

V-Lock Control

In Still mode, the 3 or 6 number key on the remote control or CH ▲▼ on the unit operate as a V-lock control to reduce jitter.

Record/Playback Time

Only use tapes with the **VHS** mark in this unit.

| Tape Speed Setting | Type of Video Cassette | | |
|-----------------------|------------------------|---------|-----------------------|
| | T60 | T120 | T160 |
| SP (Standard Play) | 1 Hour | 2 Hour | 2 Hours 40 Minutes |
| LP (Long Play) | 2 Hours | 4 Hours | 5 Hours 20 Minutes |
| SLP (Super Long Play) | 3 Hours | 6 Hours | 8 Hours |

Specifications

Display

Picture Tube: 20 inch measured diagonal
90° deflection Picture Tube (PV-C2062)
25 inch measured diagonal
110° deflection Picture Tube (PV-C2542)

VCR

Video Recording System: 4 rotary heads helical scanning system
Audio Track: 1 track

Tuner

Broadcast Channels: VHF 2 ~ 13, UHF 14 ~ 69
Midband A through I (14 ~ 22)
CABLE Channels: Superband J through W (23 ~ 36)
Hyperband AA ~ EEE (37 ~ 64)
Lowband A-5 ~ A-1 (95 ~ 99)
Special CABLE channel 5A(01)
Ultraband 65 ~ 94, 100 ~ 125

FM Radio

Band Range: 87.5 ~ 108.1 MHz

General

Power Source: 120 V AC, 60 Hz
Power Consumption: **Power On**
Approx. 110 watts (PV-C2062)
Approx. 136 watts (PV-C2542)
Power Off
Approx. 2.5 watts

Television System: EIA Standard NTSC color
Speaker: 1 piece
Operating Temperature: 5 °C ~ 40 °C (41 °F ~ 104 °F)
Operating Humidity: 10 % ~ 75 %
Weight: 23 Kg (50.6 lbs.)(PV-C2062)
31 Kg (68.2 lbs.)(PV-C2542)

Dimensions:
515 (W) X 505 (H) X 474 (D) mm
20-5/16" (W) X 19-7/8" (H) X
18-11/16" (D) (PV-C2062)
634 (W) X 590 (H) X 464 (D) mm
24-15/16" (W) X 23-1/4" (H) X
18-1/4" (D) (PV-C2542)

Note: Designs and specifications are subject to change without notice.

DST (Daylight Saving Time)

Unit auto adjusts clock for DST (Daylight Saving Time.)

■ Spring (First Sunday in April)

DST : ON => Sets clock ahead one hour.

■ Autumn (Last Sunday in October)

DST : ON => Turns clock back one hour.

- If your area does not observe Daylight Saving Time, select DST:OFF.
- Keep these time changes in mind when programming the unit for timer recordings.

Table of Contents

| | |
|-----------------------------------------------------------------|-------|
| Important Safeguards and Precautions / Safety Precautions ... | 2,3 |
| Before Using | 4 |
| Unit Information | 4 |
| Table of Contents | 5 |
| Location of Controls | 6 |
| Connections / Initial Setup (Ready to Play) | 8,9 |
| <hr/> | |
| Reset Language, Channels, Clock, Time Zone Adjust | 10,11 |
| Playback a Tape | 12 |
| Record On a Tape | 12 |
| Copy Your Tapes (Dubbing) | 13 |
| <hr/> | |
| TV Operation | 14 |
| MTS Broadcast / TV Stereo System (For model PV-C2062 only) | 15 |
| TV Timer Features | 16,17 |
| Closed Caption System | 18,19 |
| FM Radio | 20 |
| Picture Adjustment | 21 |
| <hr/> | |
| Timer Recording | 22,23 |
| <hr/> | |
| Tape Operation | 24~26 |
| Special VCR Features | 27,28 |
| V-Chip Control Feature | 29~31 |
| Cable Box Universal Remote Control Feature | 32,33 |
| <hr/> | |
| On-Screen Display (OSD) | 34 |
| Before Requesting Service | 35 |
| Servicenter List | 36 |
| Limited Warranty | 37 |
| Spanish Quick Use Guide / Guía para rápida consulta | 38,39 |
| Index | BC |

Remote Control Buttons (Light Tower™ Illuminated Remote Control)

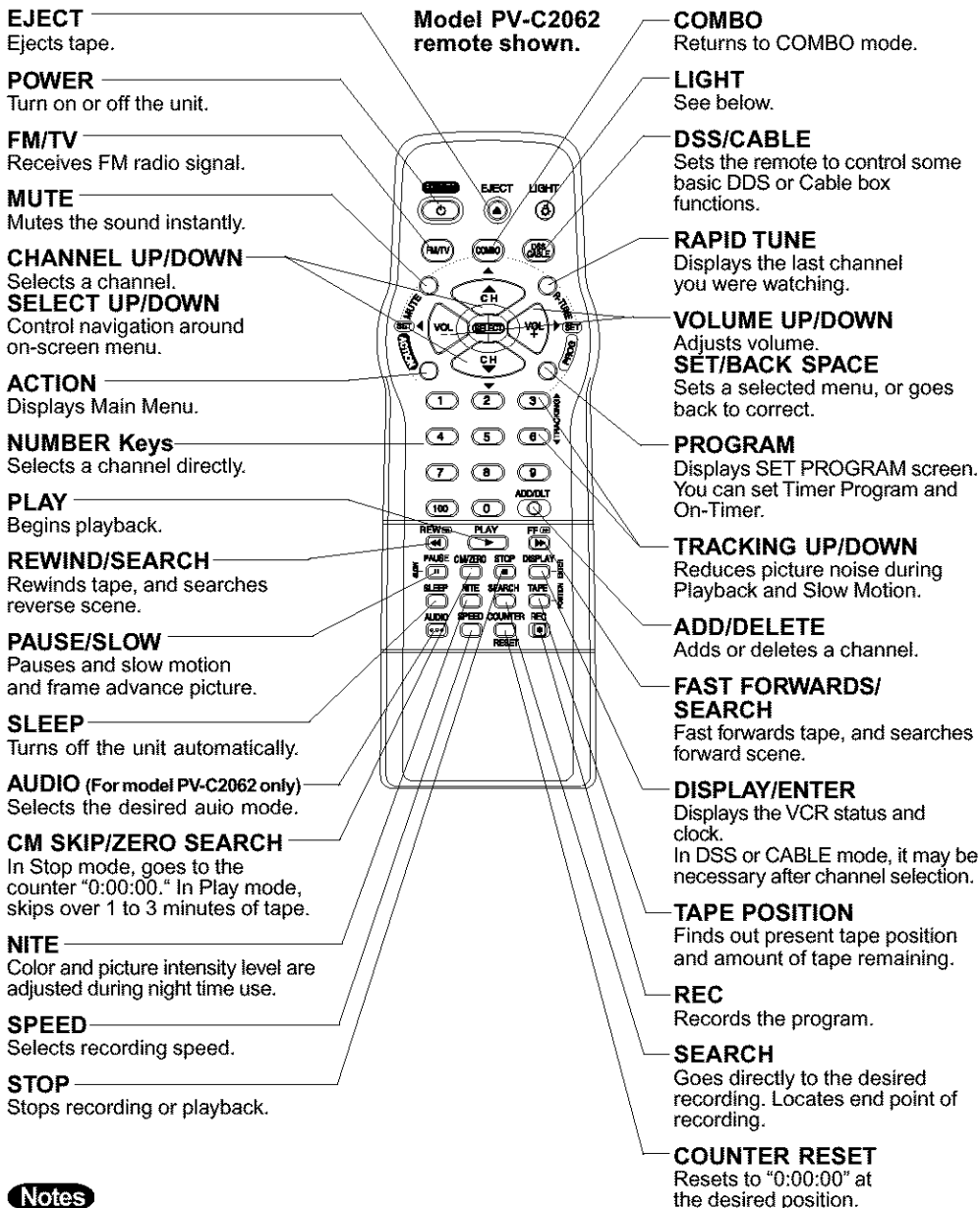

Notes

- When **LIGHT** is pressed, available buttons in the selected mode light up and the selected mode button (**COMBO** or **DSS/CABLE**) flashes for 5 seconds. If no button is pressed, light goes out in 5 seconds to conserve batteries. Also, by holding down a button, you can confirm the selected mode (mode button will flash) in the dark.
- When **EJECT** is pressed, the tape is ejected from Cassette Compartment. If **EJECT** is pressed during recording, the unit will not respond to the command.

Front View of the Unit and Indicators

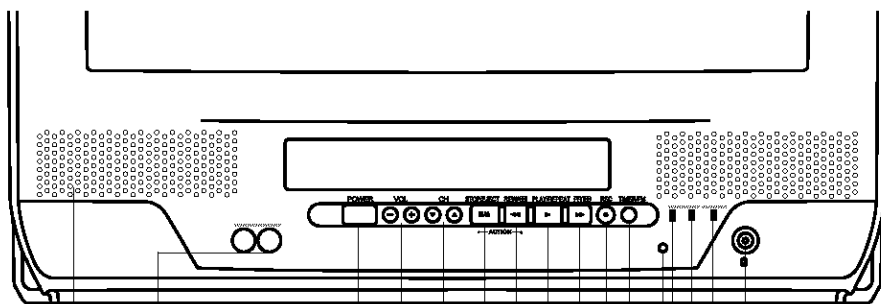

Built-In Speaker

AUDIO VIDEO IN Jack
For dubbing.

POWER
See previous page.

**VOLUME UP/DOWN
SET/BACK SPACE**
See previous page.

**CHANNEL UP/DOWN
TRACKING UP/DOWN
SELECT UP/DOWN**
See previous page.

STOP/EJECT
See previous page.
ACTION
Press together with REW.

REWIND/SEARCH
See previous page.
ACTION
Press together with STOP.

PLAY
See previous page.
REPEAT
Repeats a recording.

**FAST FORWARD/
SEARCH**
See previous page.

REC
See previous page.

TIMER/FM
Sets a timer alarm up 60 min.
Enables FM Radio.

PHONES Jack
Connect an earphone or headphones.

PROG TIMER Indicator
Lights when the unit is set for Timer Recording.

ON TIMER Indicator
Lights when the On-Timer is set.

REC Indicator
Lights during recording.

Remote Sensor
See above. See previous page.

Rear View of the Unit

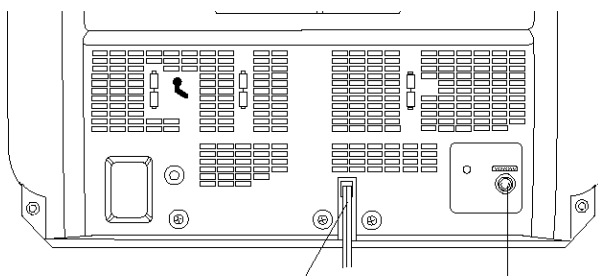

AC Power Plug
When plugged into an AC outlet, the unit consumes 2.5 W of electric power in OFF condition.

VHF/UHF Antenna Input Terminal
In from your Antenna or Cable.
Page 8

Connections/Initial Setup (Ready to Play)

Please make all cable or antenna connections before powering on.

Connecting

For ANT./Cable

Connect the cable from Antenna/Cable to the VHF/UHF terminal on the unit.

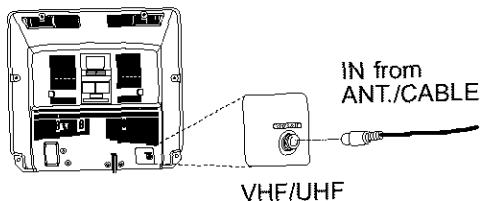

For DSS/Cable Box

Connect the OUT jack on your cable box to the VHF/UHF terminal on the unit with a RF cable.

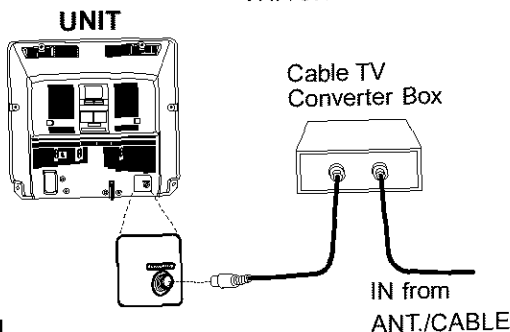

WARNING:

Overtightening "Nut type" RF coaxial cables may damage jacks. Finger tighten only.

Initial Setup (Ready to Play)

Press Combo on the remote for Combo mode.

1 Plug the unit power cord into an AC wall outlet.

2 Press Power* on the remote or unit. The unit comes on and auto channel and clock set starts.

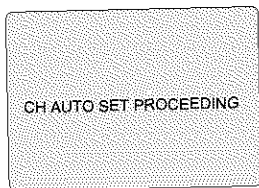

- If you use a cable box, turn it on and set it to the Public Broadcasting Service (PBS) channel in your time zone. If you use a DSS receiver, it must be turned off.

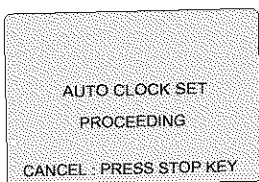

3 Settings are made automatically. When setup is done, this screen appears.

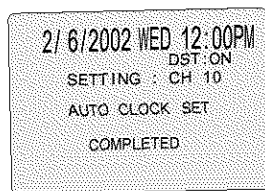

If AUTO CLOCK SET IS INCOMPLETE screen appears, set the clock using MANUAL CLOCK SET procedure as below.



Manual Clock Set

If AUTO CLOCK SET was incomplete, manually set the clock as follows.

1 Press **ACTION** on the Remote to display SET CLOCK Menu screen.

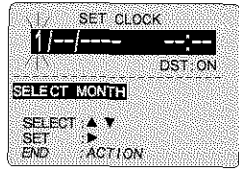

2 Press ▲▼ to select the month and press ► to set. In the same manner, select and set the date, year, time, and DST. (Daylight Saving Time)

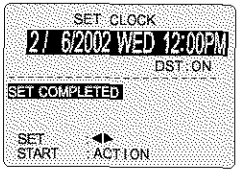

3 Press **ACTION** twice to start CLOCK and exit.

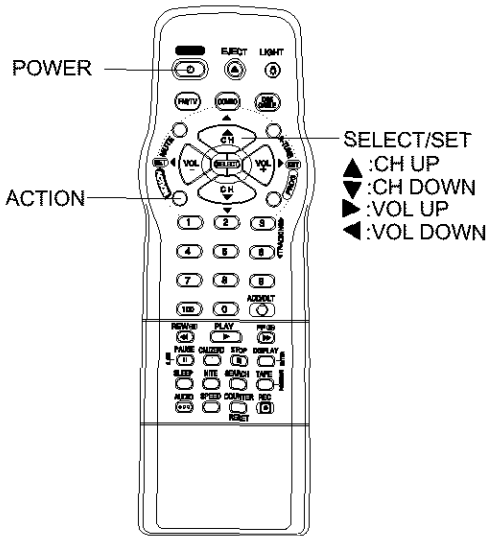

Model PV-C2062 remote shown.

Reset all unit Memory Functions

When moving unit to a new location, or if a mistake was made in the Initial Setup section.

- Make sure a tape is not inserted in the unit.

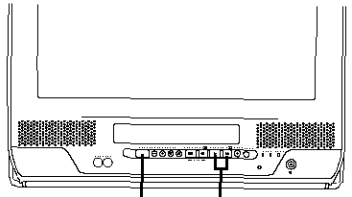

- 1 Turn the unit Power on.
- 2 Press and hold both **PLAY** and **FF** on the unit for more than 5 seconds.
 - The power will shut off.
 - Please ignore "NO CASSETTE" warning.
- 3 Do "Initial Setup" on page 8.

Note to CABLE System Installer
This reminder is provided to call the CABLE (Cable TV) System Installers attention to Article 820-40 of the NEC that provides guidelines for proper grounding and, in particular, specifies that the cable ground shall be connected to the grounding system of the building, as close to the point of cable entry as practical.

1

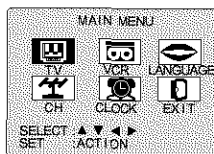

Press **ACTION***
to display MAIN MENU.

2 ■ Language

- 1) Press ▲▼◀▶ to select language icon.

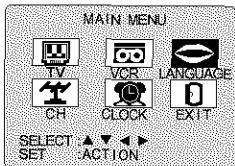

- 2) Press **ACTION** repeatedly.

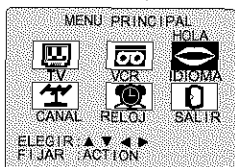

For Spanish

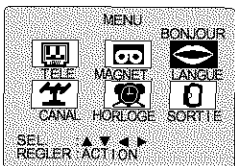

For French

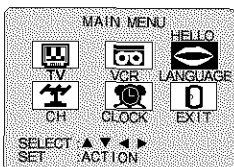

For English

- 3) Press ▲▼◀▶ to select "EXIT."
Press **ACTION** to exit.

■ Channels

- 1) Press ▲▼◀▶ to select "CH."

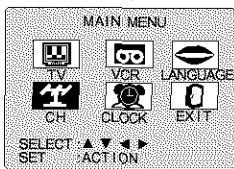

- 2) Press **ACTION**.

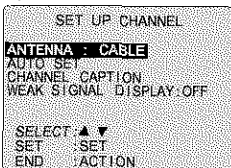

- 3) Press ▲▼ to select "ANTENNA," then press ► to set your antenna system ("TV" or "CABLE").

- 4) Press ▲▼ to select "AUTO SET," then press ►.

- After Channel Auto Set is finished, Clock Auto Set will be performed. (If clock is set manually, Clock Auto Set will not be performed.)

■ Clock

- 1) Press ▲▼◀▶ to select "CLOCK."

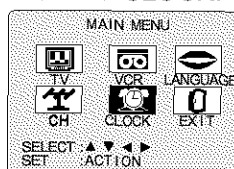

- 2) Press **ACTION**.

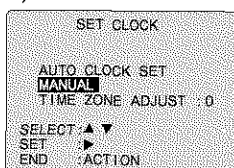

("TIME ZONE ADJUST" appears only when auto clock is set.)

- 3) Press ▲▼ to select "MANUAL" or "AUTO CLOCK SET" and press ►.

- For Auto Clock Set, select "AUTO CLOCK SET," then press "SET".

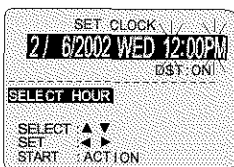

- 4) Press ▲▼ and press ◀▶ to select and set the month, date, year, time, and DST (Daylight Saving Time).

- 5) Press **ACTION** twice to start the clock and exit this mode.

10

Time Zone Adjust

*Important:

If a remote control button does not work when pressed, press the COMBO button on the remote and try the button again.

Time Zone Adjust

(Only when Auto Clock is set.)

- 1) Press **▲▼◀▶** to select "CLOCK."

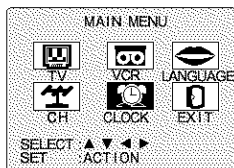

- 2) Press **ACTION**.

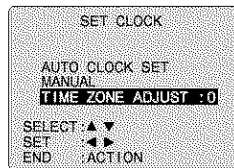

- 3) Press **▲▼** to select **TIME ZONE ADJUST** and press **◀▶** to subtract or add hour(s) as necessary.

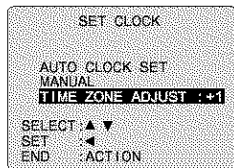

- 4) Press **ACTION** twice to exit.

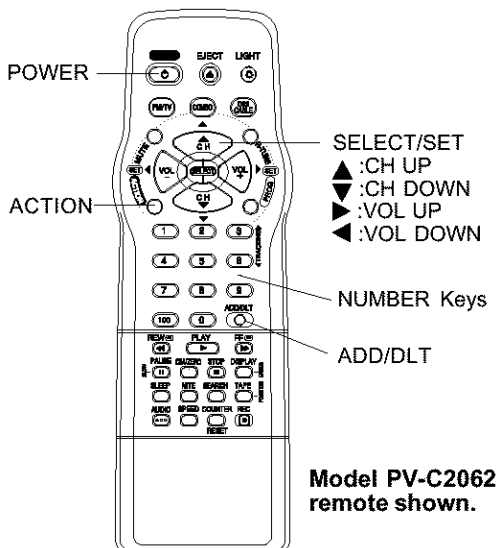

Model PV-C2062 remote shown.

ACTION key on the unit



You can operate the menu screen using unit buttons. To display the menu, press **STOP/EJECT** and **REW** together with no tape inserted. To exit the menu, repeat above with or without tape inserted until normal screen appears.

Using ▲▼◀▶ keys

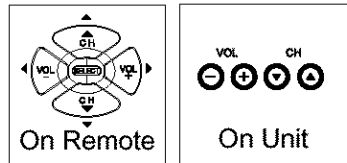

- ▲ : CH UP
- ▼ : CH DOWN
- ▶ : VOLUME UP
- ◀ : VOLUME DOWN

Whenever the menu or program screen is displayed, **CHANNEL UP/DOWN** function as **▲▼** and **VOLUME UP/DOWN** function as **◀▶** only.

Add or Delete a Channel

To add channel:
Select channel with number keys and press **ADD/DLT**.



To delete channel:
Select channel with **CH ▲▼** or number keys and press **ADD/DLT**.

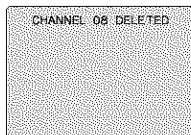

✓ Ready Check List

- All connections are made.
- Your unit is plugged in.

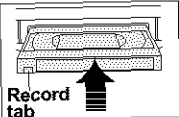
1  **Insert a cassette.**

- The unit power comes on automatically.

To prevent tape jam, remove loose or peeling labels from tapes.

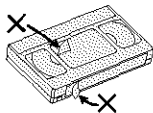

2 Press PLAY*

- Playback begins if cassette has no record tab.

- **Forward/Reverse scene search**
=> Press **FF** or **REW**
=> Press again or **PLAY** to release.
- **Still (Freeze) picture**
=> Press **PAUSE/SLOW**
=> Press **PLAY** to release.
- **Slow Motion picture**
=> Hold down **PAUSE/SLOW** in Still mode
=> Press **PLAY** to release.
- **Frame by Frame picture**
=> Press **PAUSE/SLOW** in Still mode
=> Press **PLAY** to release.

Notes

- These features work best in SLP mode.
- After the unit is in Still or Slow mode for 3 minutes, it will switch to Stop mode automatically to protect the tape and the video head.

- **Stop => Press STOP**
- **Rewind tape => Press REW** in Stop mode
- **Fast forward tape => Press FF** in Stop mode
- **Eject tape => Press EJECT** on the remote or **STOP/EJECT** on the unit

You can operate on the unit

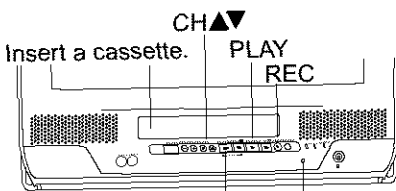

- Press to stop and/or eject tape REC Indicator

1 Insert a cassette with record tab.

- The unit power comes on automatically.

2 Press CH ▲▼ or number keys to Select Channel.

- For "LINE" input, see bottom of next page.

3 Press SPEED to select recording speed (see page 4).

- SP = Standard Play
- LP = Long Play
- SLP = Super Long Play
- Selected speed is displayed.

4 Press REC to start recording.

- To edit out unwanted portions, press **PAUSE/SLOW** to pause and resume recording.
- You cannot view another channel during recording.

- **Stop => Press STOP**
- **One Touch Recording (OTR)**

Press **REC** repeatedly to set the recording length (30 min - 4 hours).

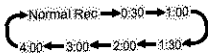

- The unit stops recording at a preset time.
- **PROG TIMER** indicator lights on the unit.

Notes

- After the unit has been in Rec Pause mode for 5 minutes, it will stop automatically to protect the tape and the video head.
- The remaining recording time of an OTR can be displayed by pressing **DISPLAY**.

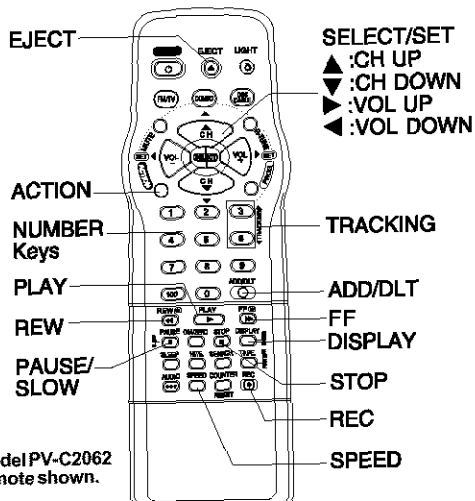

Model PV-C2062 remote shown.

Copy Your Tapes (Dubbing)

***Important:** If a remote control button does not work when pressed, press the COMBO button on the remote and try the button again.

Connections you'll need to make.

Playing (Source) VCR

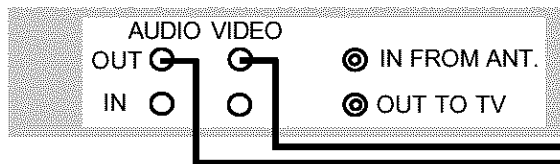

Recording (Editing) unit

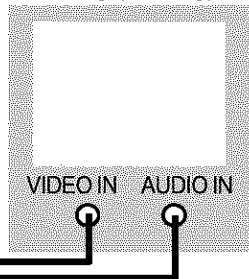

Basic Operation

Playback (Source)

Recording (Editing) unit

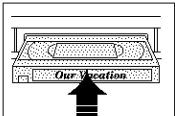
1  **Insert pre-recorded tape.**

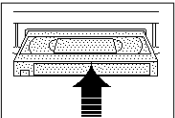
 **Insert blank tape with record tab.**

- Dubbing tapes protected with Copy Guard will have poor quality results.

2 _____

Select "LINE" mode.
See "Selecting Input Mode" below.

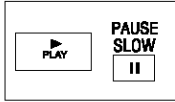
3  **Press PLAY then PAUSE** at starting point to put in Standby mode.

 **Press REC, then PAUSE/SLOW** immediately to put in Standby mode.

(Perform operation of steps 4 and 5 on both units at same time.)

4  **Press PLAY** to start dubbing.

 **Press PAUSE/SLOW** to start dubbing.

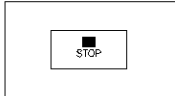
5  **Press STOP** to stop dubbing.

 **Press STOP** to stop dubbing.

Caution

- Unauthorized exchanging and/or copying of copyrighted recordings may be copyright infringement.

Selecting Input Mode

Method 1:

Press CH ▲▼. The display will change as follows.

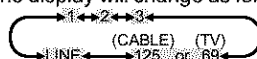

Method 2:

- Press **ACTION** for MAIN MENU.
- Press ▲▼◀▶ to select "TV", then press **ACTION** for SET UP TV screen.
- Press ▲▼ to select "INPUT SELECT," and then press ▶ to select "TUNER" or "LINE."
- Press **ACTION** twice to exit this mode.

TV Operation

***Important:** If a remote control button does not work when pressed, press the COMBO button on the remote and try the button again.

1 Press **POWER*** on the remote or unit.

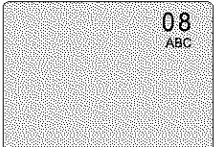
2  Use **CH ▲▼** or **number keys** to select a channel.

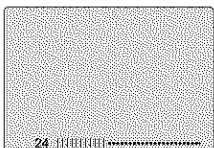
3  Press **VOL +** or **VOL -** to adjust volume.

Ready Check List

- All connections are made.
- Your unit is plugged in.

NIGHT (NITE) Mode

Color and picture intensity levels are adjusted so the screen is easier on your eyes during night time use.

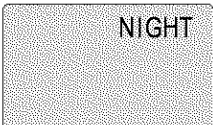
 **NIGHT** Press **NITE** to set **NIGHT** mode.

- NIGHT mode may be selected when watching TV or playing a tape.

Press **NITE** to cancel.

- Previous settings are restored.
- NIGHT mode is canceled when power is turned off or power failure occurs.

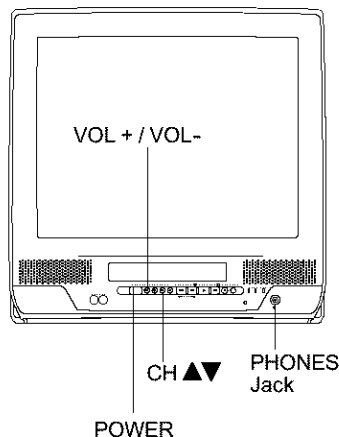

■ Using the 100 key

When selecting **CABLE** channels 100 to 125 with the number keys, first press the 100 key, and then enter the remaining two digits.

■ Rapid Tune

Press **R-TUNE** to display the last channel you were watching.

■ Audio Mute

Press **MUTE** to instantly mute the sound. Press again to restore the previous sound level.

■ Phones

Connect an earphone (not supplied) or headphones (not supplied) to the **Phones Jack**.

MTS Broadcast/TV Stereo System

For Model PV-C2062 only

Equipped with **dbx**[®] -TV Noise Reduction for true MTS reproduction. **dbx**[®] -TV Noise Reduction is required for good stereo separation and audio fidelity. **dbx**[®] is a registered trademark, and is licensed by **dbx**[®] Technology Licensing.

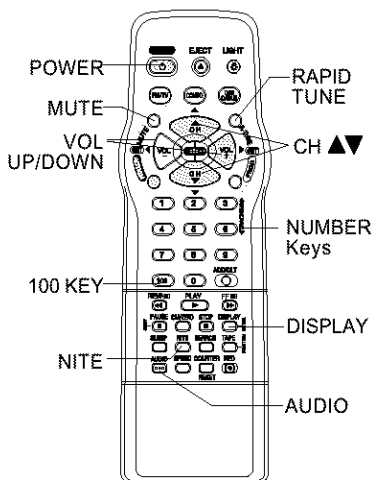

Receivable Broadcast Types

The following are possible audio broadcast types and on-screen displays. The signal being received is indicated with an "⊕" mark while the selected audio mode is indicated with an arrow. To change the audio mode for these broadcasts, see the "Select Audio Mode for TV Viewing" section (below.)

Press **DISPLAY** to display the broadcast signal being received.

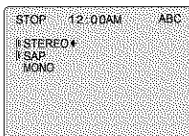

MTS Stereo and SAP broadcast

Multi-channel Television Sound Stereo (main language) and Secondary Audio Program (sub language) broadcasts are being received simultaneously. Select the STEREO or SAP audio mode.

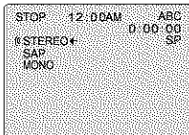

MTS Stereo broadcast

Multi-channel Television Sound Stereo broadcast. Select STEREO audio mode.

- If stereo broadcast is weak and the display flickers, select MONO audio mode for possibly better results.

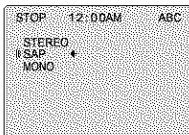

SAP broadcast

Secondary Audio Program (sub language).

Select SAP audio mode for the sub language.

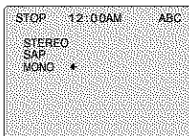

MONO broadcast

Normal monaural sound broadcast.

TV Operation

Select Audio Mode for TV Viewing

Press **AUDIO** to select the desired audio mode as described above.

(Arrow shows selection.)

- Each press of AUDIO will change the audio mode as shown below.
- "SAP" is selected with first press of AUDIO.

< Example >

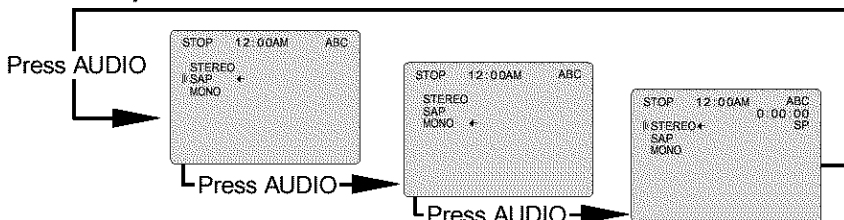

IMPORTANT NOTE:

- This stereo system is designed for TV viewing only. Recording and playback will always be in monaural.

ON-TIMER with Alarm

This unit can be set to automatically power on in one of 2 modes (TV, Playback, or FM radio). You can also combine the On-Timer with a one minute alarm that gradually increases in volume.

1 Press **PROG*** to display SET PROGRAM screen.



1) Press **▲▼** to select "ON TIMER."
2) Press **▶** to display ON TIMER screen.

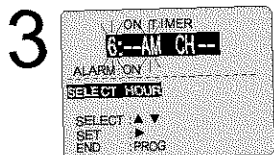

- ON-TIMER mode selection order

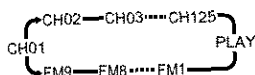

1) Press **▲▼** to select desired settings.
2) Press **▶** to set the ON-TIMER TIME or ON-TIMER mode.

- Make sure a tape is inserted if Playback mode is selected.
- See "FM Radio" on page 20 for instructions on how to preset FM stations.

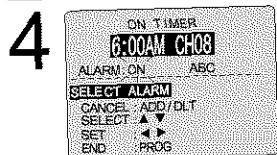

Press **▲▼** to select ALARM "ON" or "OFF."

When "ON" is selected, an alarm will gradually increase in volume for one minute or until canceled by pressing any button (including VOL + -).

To Make Corrections, use **▲▼** and **◀▶** to move back and correct.

5 Press **PROG** to set ON TIMER.
• "ON TIMER SET" is displayed.
• ON TIMER Indicator lights on the unit.

To Cancel ON-TIMER set, Repeat steps 1 and 2. Then, press **ADD/ DLT** to clear the time in step 3. Now, press **PROG** to end. "ON TIMER END" briefly appears on-screen.

Ready Check List

- The clock is set to correct time.

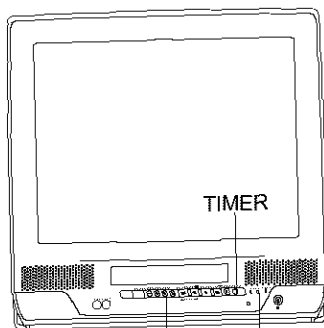

CH **▲▼** ON TIMER indicator

Note

- If no button on the remote or unit (including a button used to turn off the alarm) is pressed within 60 minutes after unit turns itself on, it will turn itself back off.

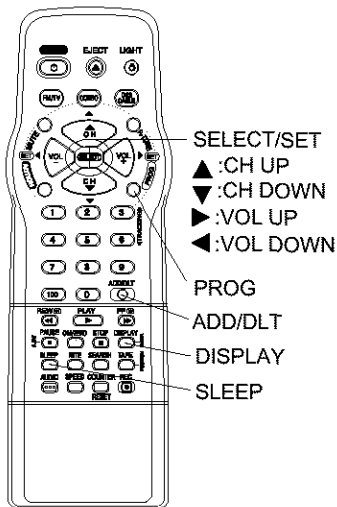

Model PV-C2062 remote shown.

Sleep Timer

This unit can be set for auto power off.

Press SLEEP repeatedly to set SLEEP TIMER.

- Pressing **DISPLAY** with sleep timer set displays remaining time.

Press SLEEP repeatedly until "SLEEP TIMER 00" appears to cancel.

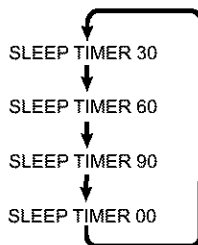

Instant Alarm

You can set a timer alarm up to 60 min. Useful when you are cooking, etc.

1 Press TIMER/FM on the unit to display the instant alarm CANCEL/SET screen.

2 Press CH ▲▼ on the unit with CANCEL/SET screen displayed to set alarm. (Time changes in the order shown left.)

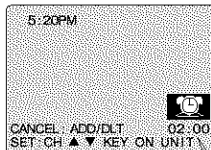

Remaining Time

- Pressing **TIMER/FM** repeatedly on the unit will change display as follows.



To cancel, press **TIMER/FM** then press **ADD/DLT** on the remote while **CANCEL/SET** screen is displayed.

To increase timer in progress, repeat step 2. Time will be rounded up to next 1, 5, or 10 minute interval. (See chart left.)

<Example>

- If current time remaining is 12:15, countdown will restart from 15:00.
- If current time remaining is 9:15, countdown will restart from 10:00.

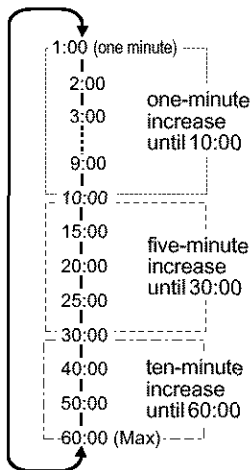

Note

- While timer function is in progress, you can change channels on the unit with **CH ▲▼** while "CANCEL/SET" screen is not displayed.

3 Alarm will sound at 0: 00. Press any button to stop

- The volume of the alarm gradually increases for one minute and then continues to beep until any button is pressed.

Closed Caption System

Closed Caption is ...

This multi-use system not only allows the hearing impaired to enjoy selected programs, but also makes useful information from TV stations available to everyone.

Closed Caption Mode Feature

1 Press **ACTION*** to display MAIN MENU.

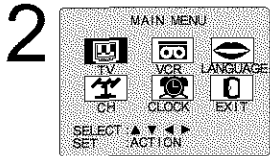

- 1) Press **▲▼◀▶** to select "TV."
- 2) Press **ACTION** to display SET UP TV screen.

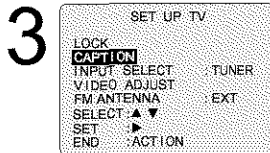

- 1) Press **▲▼** to select "CAPTION".
- 2) Press **▶** to display CAPTION screen.

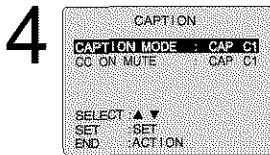

- 1) Press **▲▼** to select CAPTION MODE.
- 2) Press **▶** repeatedly to select mode. (See left.)

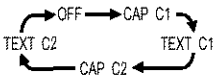

5 Press **ACTION** three times to return to the normal screen.

Closed Caption Mode Selections

Caption Mode: CAP C1 or C2

A narration of selected TV programs is displayed. Check TV program listings for CC(Closed Caption) broadcasts.

Caption Mode: TEXT C1 or C2

The lower half of the screen will be blocked out. When the TV station broadcasts information, such as program listings, it will appear in this space.

Caption Mode: OFF

Closed Caption / Text narration will not be displayed.

NOTE :

The closed caption or text signal may be broadcast over C1, C2, or both. Also, text contents can vary so you may wish to try different settings.

Recording and Playing Back a Closed Caption/Text Program

- Record:** Record normally.
Closed Caption/ Text signal, if present, is recorded automatically.
- Playback:** Start playback. Do above steps to select desired caption mode.

Caption On Mute Feature

Closed Caption narration, if available, is displayed when MUTE button is pressed for silence.

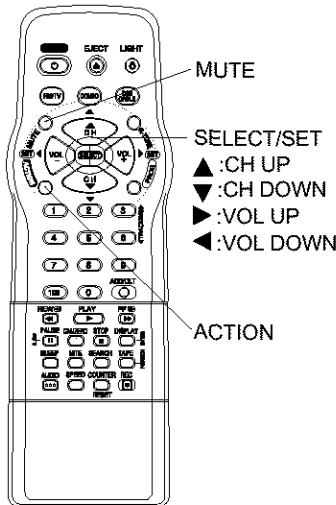

Model PV-C2062 remote shown.

1 Press **ACTION** to display MAIN MENU.

2

MAIN MENU

| | | |
|----|-------|----------|
| | | |
| TV | VCR | LANGUAGE |
| | | |
| CH | CLOCK | EXIT |

SELECT ▲▼◀▶
SET ACTION

1) Press **▲▼◀▶** to select "TV."

2) Press **ACTION** to display SET UP TV screen.

3

SET UP TV

LOCK

CAPTION

| | |
|--------------|-------|
| INPUT SELECT | TUNER |
| VIDEO ADJUST | EXT |
| FM ANTENNA | |

SELECT ▲▼◀▶
SET ACTION
END ACTION

1) Press **▲▼** to select "CAPTION".

2) Press **▶** to display CAPTION screen.

4

CAPTION

CAPTION MODE : OFF

CC ON MUTE : CAP C1

SELECT ▲▼
SET SET
END ACTION

1) Press **▲▼** to select CAPTION MODE.

2) Press **▶** repeatedly to select "OFF."

5

CAPTION

CAPTION MODE : OFF

CC ON MUTE : CAP C1

SELECT ▲▼
SET SET
END ACTION

1) Press **▲▼** to select CC ON MUTE.

2) Press **▶** repeatedly to select desired mode.

- Each press of **▶** will change the display as shown left.
- The caption may be broadcast over CAP C1 or C2.

NO → CAP C1

← CAP C2

6 Press **ACTION** three times to return to the normal screen.

7 Press **MUTE** to mute the sound and display closed captioning.

- To cancel, press MUTE again.

FM Radio is ... This unit has an FM radio with built-in antenna, 9 station preset, and a band range of 87.5 ~ 108.1 MHz. You can even set the On-Timer (page 16) to wake up to your favorite radio station.

FM Radio Setup

1 Press **FM/TV*** on the remote or press **TIMER/FM** twice on the unit to display FM radio mode.

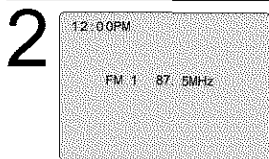

Press a number key (1~9) to select the FM number.

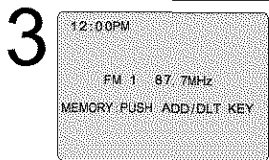

1) Press **CH ▲▼** to select the desired radio station. (Each press changes frequency 200 KHz.)

2) Press **ADD/ DLT** to set the radio station.

Hold down CH ▲ or ▼ for a few seconds, then release to quickly scan for FM stations in your area.

• To cancel, press **CH ▲** or **▼** while in search mode.

To Make Corrections, select station with a number key, then do step 3 again.

To exit FM mode, press **FM/TV** on the remote or **TIMER/FM** twice on the unit.

Note

- FM radio cannot be recorded on a Video cassette.
- You may get better reception by repositioning the unit.
- You cannot select FM Radio mode during playback or record, or while a blue back screen (PROG, ACTION, MENU) is displayed.
- Once stations are set, the selected station and current time are displayed when FM Radio mode is entered. To remove time, press **DISPLAY**. If **DISPLAY** is pressed again, the unit status screen appears.

FM ANTENNA Setup

Make sure FM tuning is done correctly (see FM Radio Setup).

1 Press **ACTION** to display MAIN MENU.

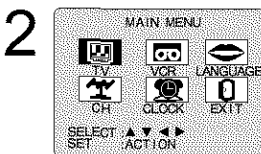

1) Press **▲▼◀▶** to select "TV."
2) Press **ACTION** to display SET UP TV screen.

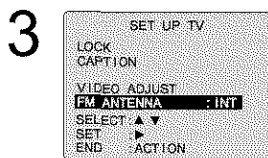

1) Press **▲▼** to select FM ANTENNA.
2) Press **▶** to select "INT (INTERNAL)" or "EXT (EXTERNAL)" whichever sounds the best.

- For cable TV users => "INT"
- For antenna users => "EXT"

4 Press **ACTION** twice to end setup.

How to use the FM radio

1 Press **FM/TV** on the remote or press **TIMER/FM** twice on the unit to display FM radio mode.

2

Press a Number key (1~9) to select a preset FM number (see steps 2 and 3 on this page).

To cancel, press **FM/TV** on the remote or **TIMER/FM** twice on the unit.

To select Audio Mode for FM Radio

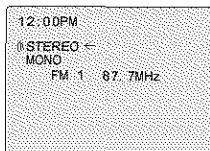

Press **AUDIO** repeatedly to select "STEREO" or "MONO" in FM Radio mode.

1 Press ACTION to display MAIN MENU.

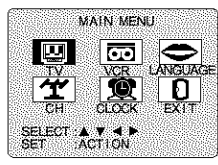

- 1) Press ▲▼◀▶ to select "TV."
- 2) Press ACTION to display SET UP TV screen.

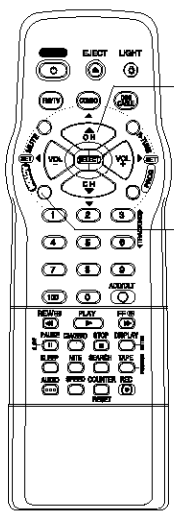

- SELECT/SET
 ▲ :CH UP
 ▼ :CH DOWN
 ▶ :VOL UP
 ◀ :VOL DOWN
 ACTION

3

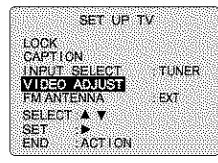

- 1) Press ▲▼ to select VIDEO ADJUST.
- 2) Press ▶ to display screen.

4

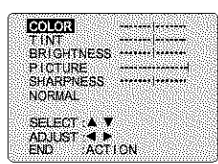

- 1) Press ▲▼ to select an adjustment item. (See below left.)
- 2) Press ◀▶ to adjust.

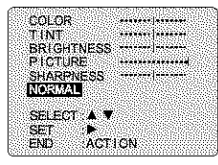

To Reset Picture Controls.
 Press ▲▼ and ▶ to select and set "NORMAL."
 All controls return to their factory settings.

Model PV-C2062 remote shown.

Picture Adjustment

- **COLOR Control**
Adjust color intensity.
- **TINT Control**
Adjust for natural flesh tones.
- **BRIGHTNESS Control**
Adjust picture brightness.
- **PICTURE Control**
Adjust picture intensity by adjusting both contrast and color level in the proper balance.
- **SHARPNESS Control**
Adjust picture sharpness.

5 Press ACTION three times to exit.

TV Operation

Timer Recording

You can set up to 8 programs to be recorded while you are away.

1 Press **PROG*** to display SET PROGRAM screen.

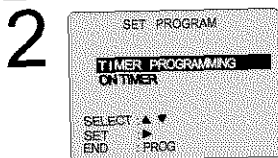

1) Press **▲▼** to select **TIMER PROGRAMMING**.
2) Press **▶** to display screen.

- If a program is already in memory, press **▲▼**, and **▶** to select an unused program number.

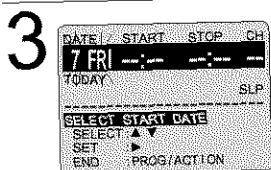

Press **▲▼** to select and **▶** or **◀** to set the recording DATE.

- 1-31 = One time
- DAILY = MON~FRI
- WEEKLY SUN~SAT = Same time once a week

Example

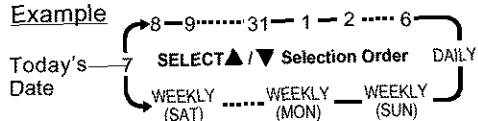

Repeat step 3 to set:

- start time, stop time
- Channel (or LINE for outside source)
- Speed (SP, LP, SLP)

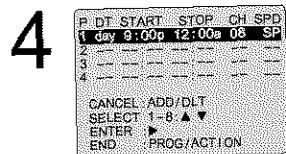

Press **PROG** (or **ACTION**) to end the program.

To Enter More Programs, press **▲▼** to select and **▶** to set a blank program number, and then repeat step 3.

5 Press **PROG** twice (or **ACTION**) to exit this mode.

- If you're using a cable box, make sure that it is tuned to the desired channel and the power is left on for timer recording.
- PROG TIMER indicator lights on the unit.

✓ Ready Check List

- All connections are made.
- Your unit is plugged in.
- The clock is set to correct time.
- The tape is long enough.
- The record tab is in place.

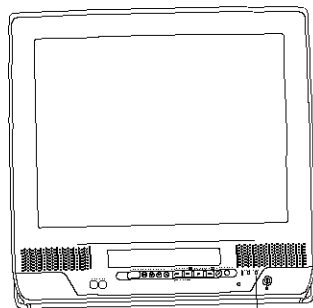

PROG TIMER indicator

Timer Recording Using unit Buttons

You can set a Timer Recording using **ACTION** key on the unit. (See page 11.)

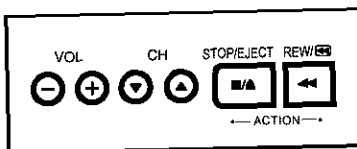

- 1 Press **STOP/EJECT** and **REW** together without a tape inserted to display **MAIN MENU**.
- 2 Press **▲▼ + -** to select "VCR" and **STOP/EJECT** and **REW** together to display **SET UP VCR** screen.
- 3 Press **▲▼** to select "TIMER PROGRAM" and **+** to display the **TIMER PROGRAM** screen.
- 4 Repeat main steps 3 - 5.

Cancel a Timer Recording: (Recording is in progress)

Hold down STOP for a few seconds to cancel the Timer Recording.

- Any future daily or weekly recordings will be performed as programmed.

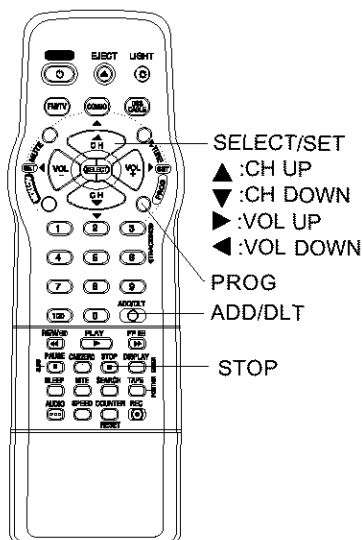

Model PV-C2062 remote shown.

Review, Replace or Clear Program Contents : (Recording is not in progress)

1 Repeat steps 1 and 2 on page 22.

2

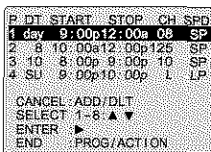

Press ▲▼ to select the desired program.

3

To Replace program...

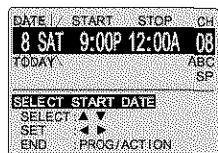

- 1) Press ▶ to display.
- 2) Press ▲▼ to select and press ◀ or ▶ to set new program contents.
- 3) Press PROG (or ACTION).

To Clear program...

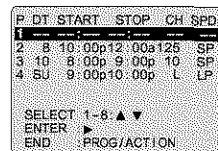

Press ADD/DLT.

4

Press PROG twice (or ACTION) to exit this mode.

Notes

- 2 minutes before Timer recording is performed, "PLEASE PREPARE FOR TIMER REC" appears and/or the PROG TIMER indicator flashes. Be sure a cassette with record tab is loaded and the unit is in Stop mode.
- If the start times of two programs overlap, the lower numbered program will have priority.
- If the start time for a Timer Recording comes up during a normal recording or One Touch Recording (page 12), the Timer Recording will not be performed.
- If there is a power interruption of more than one minute, the recording may not be performed or continued.
- If "INCOMPLETE" appears after all items have been set, check all entries and make necessary corrections.

Search System is ...

Each time a recording is made, an invisible index mark is placed on the tape. When timer recordings are made, program index and information are also included. These index marks can be used to access or scan recordings.

Index Search

Go directly to the desired recording.

1

INDEX SEARCH
ENTER INDEX NUMBER:1
USING 1-9 KEYS

FORWARD SEARCH:FF
REVERSE SEARCH:REW
NEXT SEARCH
EXIT: STOP

Press **SEARCH*** in Playback or Stop mode to display INDEX SEARCH screen, and then press **NUMBER KEYS** to select the recording number.

• To calculate number, see below.

Press **FF** or **REW** to start search.

2

INDEX SEARCH

FORWARD SEARCH:FF
REVERSE SEARCH:REW

Play begins at search end. To search forward or back 1 index, press **FF** or **REW** while screen left is displayed (10 sec.).

■ To calculate the Index Number

Example 1:

To go to rec. 2 from rec. 4, enter 3 and press **REW**.

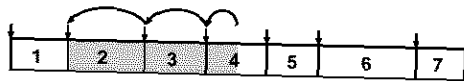

Example 2:

To go to rec. 6 from rec. 2, enter 4 and press **FF**.

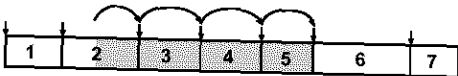

NOTE: ↓ indicates start points of each recording.

Notes

- Make each entry within 10 seconds, or the Index Search mode will be canceled.
- If Index Search is started very close to an index mark, that index mark may not be counted in the search.

Program End Search

Locates end point of recording for continuity.

1
2

Press **SEARCH** twice in Playback or Stop mode to display **PROGRAM END SEARCH** screen

Press **FF** to start search.

PROGRAM END SEARCH

SEARCH START:FF

EXIT SEARCH

Example of Program End Search operation.

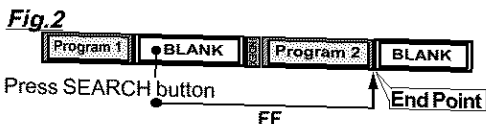
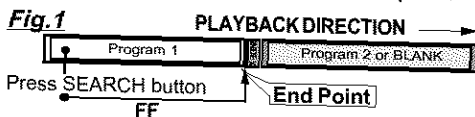
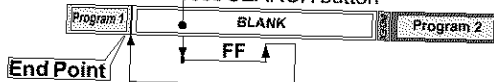
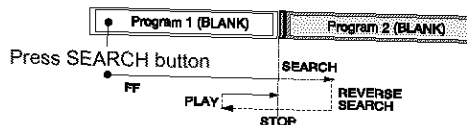

Fig.3 If search exceeds a few seconds in BLANK area, Press **SEARCH** button



Upon locating end point...

The unit searches slightly past end point, reverse searches, and plays the last few seconds of the program, then stops.



Notes

- If Program End Search is started very close to an index mark, that mark may be skipped over.
- To cancel, press **PLAY** or **STOP**.

***Important:** If a remote control does not work when pressed, press the button again on the remote and try the button again.

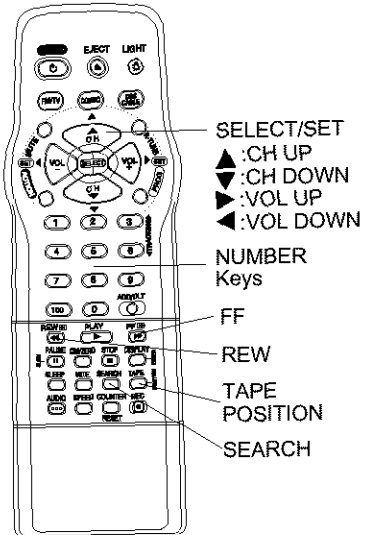
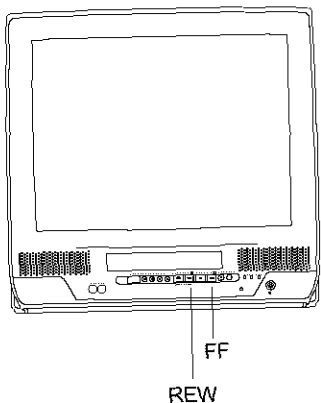

Model PV-C2062 remote shown.

Auto Operation Functions

- Auto Shut Off**
 No broadcast signal in TV (Only when Weak Signal Display is set to OFF), blank tape is Played for 5 minutes => Power turns off

 - This feature is canceled if any button is pressed during above mode.
- Auto Playback**
 Insert a tape in Power off mode => Power turns on

 - Playback begins if tape has no record tab.
- Auto Rewind**
 Tape reaches its end => Rewind => Stop
- Playback Auto Eject (Repeat Play is "OFF")**
 Tape with no record tab reaches its end
 Rewind => Stop => Eject

Tape Position Display

To find out present tape position and amount of tape remaining.
Tape position is displayed for VHS-C Cassettes type, tapes under 30 minutes, and some other tapes, but the position is not correct.

1 Press TAPE POSITION to detect current tape position.

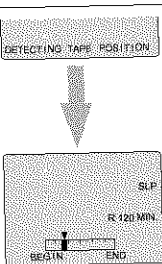

- "DETECTING TAPE POSITION" is displayed only when a cassette is first inserted and it takes several seconds for correct tape position to appear.
- The present tape position indication and amount of tape remaining (according to tape speed) is displayed.
- Tape remaining time display may not be precise.

Advanced Operation

2 Press TAPE POSITION (or wait 5 seconds) to return to normal screen.

Note

- This function cannot display exact amount of tape remaining for tapes 30 minutes or less, or for tapes over 120 minutes in length.

Tape Operation (continued)

***Important:** If a remote control button does not work when pressed, press the COMBO button on the remote and try the button again.

Zero Search

To quickly return to a specific tape counter location.

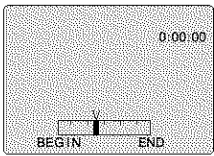
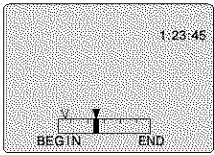
- 1 Press **DISPLAY*** during playback to display the Counter.
- 2  Press **COUNTER RESET** at the desired position to reset to "0:00:00."
- 3 Continue playback, rewind, or fast forward.
- 4 Press **STOP**.
- 5  Press **CM/ZERO** in stop mode to start **ZERO SEARCH**.
 - ▼: Present position mark
 - √: Zero position mark
 - Unit goes into FF or REW mode and stops at the last point the Counter was set to 0:00:00.

Note

- If a blank portion exists on the tape, and depending on the position of the √ mark, the √ mark display may be out of position.

Commercial Skip

By pressing the **CM/ZERO** button in Playback mode you can skip over 1 to 3 minutes of recorded tape in just a few seconds.

- 1 Press **CM/ZERO** repeatedly to select skip time in Play mode.
 - No indication appears.

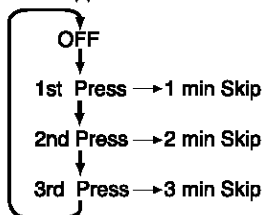

Repeat Play

Set to see a recording over and over.

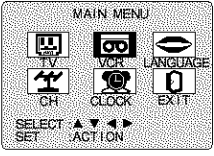
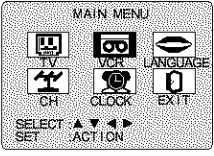
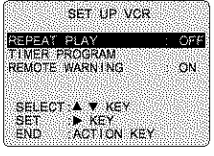
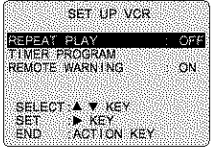
- 1 Press **ACTION** to display **MAIN MENU**.

- 2  1) Press **▲▼◀▶** to select "VCR."
2) Press **ACTION** to display **SET UP VCR** screen.

- 3  1) Press **▲▼** to select "REPEAT PLAY."
2) Press **▶** to set **REPEAT PLAY** "ON" or "OFF."

- 4 Press **ACTION** twice to end setup.

Notes

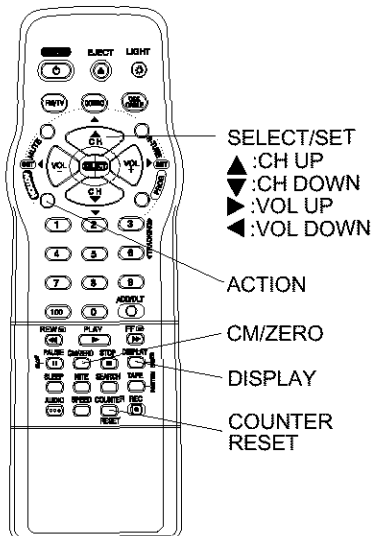
- Playback repeats when tape end is reached or unrecorded portion over 30 seconds is detected.
- During playback, you may also press **PLAY/REPEAT** repeatedly on the unit to select **REPEAT "ON"** or **"OFF."**

Special VCR Features



Model PV-C2062 remote shown.

Weak Signal Display ON/OFF

When "ON" is selected, the picture is displayed even when a broadcast signal is weak or non-existent.

1 Press **ACTION** to display MAIN MENU.

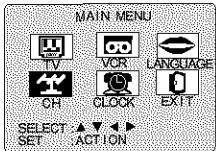
2  1) Press **▲▼◀▶** to select "CH."
2) Press **ACTION** to display SET UP CHANNEL screen.

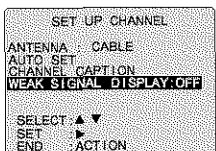
3  1) Press **▲▼** to select WEAK SIGNAL DISPLAY.
2) Press **▶** to set "ON" or "OFF."

Notes

- "ON" = Picture is displayed regardless of signal condition, and may not always be clearly visible.
- "OFF" = Screen turns solid blue when signal is absent or weak.
- If unit is connected to equipment which has blue back feature, selecting "ON" will have no effect on the other equipment.

4 Press **ACTION** twice to return to the normal screen.

VCR Lock

All operations are prohibited except Timer recording and tape eject. Useful for families with small children.

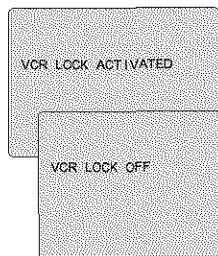

In stop mode, **hold down REC** on the unit without a cassette inserted for 7 seconds to turn "ON." Please ignore NO CASSETTE warning.

Repeat above with or without cassette to turn "OFF."

- VCR Lock is canceled automatically after about 24 hours if clock is set.
- "Auto Power On" is not prohibited when VCR Lock is activated.

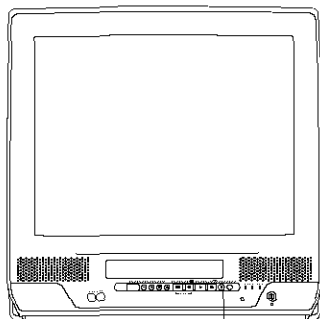

Special VCR Features (continued)

***Important:** If a remote control button does not work when pressed, press the COMBO button on the remote and try the button again.

Channel Caption is ...

Station names, e.g. ABC, TNN, etc. are set so they will appear when a channel is selected. Choose 24 preset names.

Channel Caption

1 Press ACTION* to display MAIN MENU.

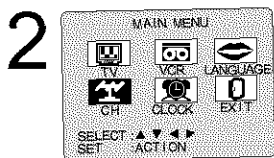

- 1) Press ▲▼◀▶ to select "CH."
2) Press ACTION to display SET UP CHANNEL screen.

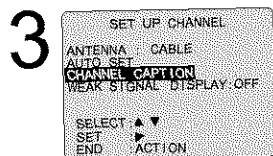

- 1) Press ▲▼ to select CHANNEL CAPTION.
2) Press ► to display screen.

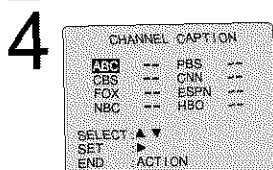

- 1) Press ▲▼ to select a station.
2) Press ► to move cursor to the right.
3) Press ▲▼ to select channel number.

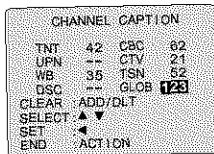

- 4) Press ◀ to set preset captions.
• Repeat step 4 until the Caption List is complete.

To Make Corrections

Press ▲▼, then ► to select channel number.
Press ▲▼ to change, or ADD/DLT to delete.

5 Press ACTION four times to end setup.

Remote Warning ON/OFF

When Universal Remote Control (page 32) is used, and this feature is set to "ON," a warning appears whenever an invalid key is pressed in DSS or Cable mode.

1 Press ACTION to display MAIN MENU.

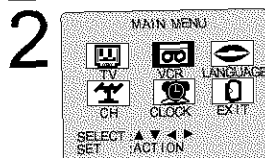

- 1) Press ▲▼◀▶ to select "VCR."
2) Press ACTION to display SET UP VCR screen.

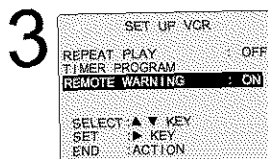

- 1) Press ▲▼ to select REMOTE WARNING.
2) Press ► to set "ON" or "OFF."

• "REMOTE WARNING : OFF"

-> Remote warning will not appear even if invalid key is pressed.

4 Press ACTION twice to return to normal screen.

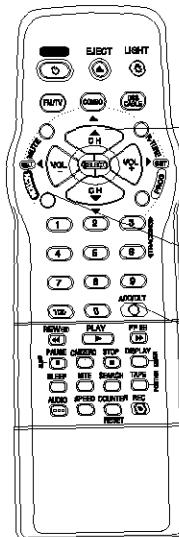

SELECT/SET
▲ :CH UP
▼ :CH DOWN
◀ :VOL UP
▶ :VOL DOWN

ACTION

ADD/DLT

Model PV-C2062 remote shown.

V-Chip Control Feature

Process of V-Chip Control

Enter Code → **Setup** → **Blocking**

V-Chip Control Feature is...

This unit has a built-in V-Chip Control which allows you to block unwanted TV usage based on US MOVIES and US TV PROGRAMS Ratings.

Enter Secret Code

A 4-digit code must be entered to view a blocked program or change rating settings.

1 Press **ACTION** to display MAIN MENU.

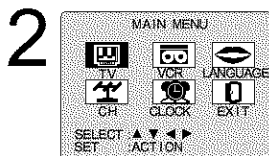

- 1) Press **▲▼◀▶** to select "TV."
- 2) Press **ACTION** to display SET UP TV screen.

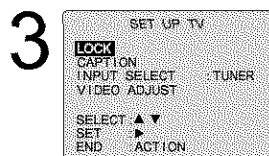

- 1) Press **▲▼** to select LOCK.
- 2) Press **▶** to display screen.

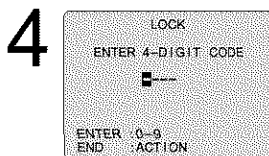

- 1) Press **NUMBER Keys** to enter your secret code.
- 2) Enter same code again for confirmation.

To Make Corrections
Press **◀** repeatedly to move the cursor. Press number keys to make the correction.

- Step 2) not necessary when changing rating or secret code.
- Take care that you are not observed entering the secret code.

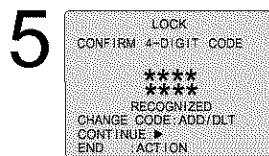

Press **▶** to display US Ratings menu (see page 30).

Or
Press **ACTION** three times to exit.

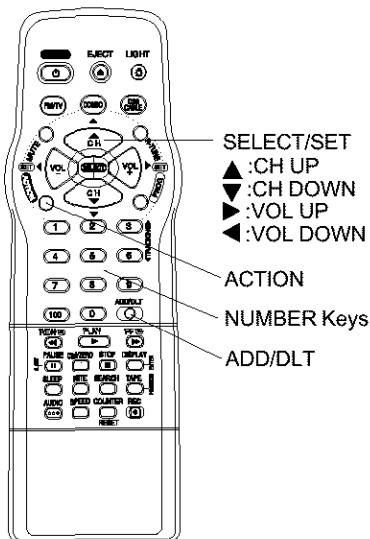

Model PV-C2062 remote shown.

Changing your secret code

- You will need your current code. Do steps 1 ~ 4. In step 5, press ADD/DEL to clear current code. Repeat steps 4 and 5 to enter new code.

Notes

- DO NOT forget your secret code.
- Once ratings are set, restricted tapes or programs cannot be accessed unless the secret code is entered.

V-Chip Control Feature (continued)

If LOCK menu is not displayed, do "Enter Secret Code" steps on page 29.

Process of V-Chip Control Feature

Enter Code → Setup → Blocking

Setup US MOVIES Ratings

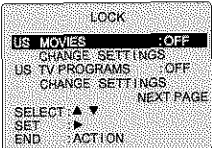
- 1) Press **▲▼*** to select **US MOVIES**.
- 2) Press **▶** to set "ON" or "OFF."
- 
- "ON" => V-Chip Control is activated.
 - "OFF" => V-Chip Control is deactivated.

Note

- "NEXT PAGE" displays CANADIAN V-Chip setting menu. Not necessary except when viewing Canadian tapes or broadcasts.

Setup US TV PROGRAMS Ratings

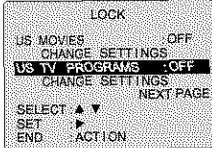
- 1) Press **▲▼** to select **US TV PROGRAMS**.
- 2) Press **▶** to set "ON" or "OFF."
- 
- "ON" => V-Chip Control is activated.
 - "OFF" => V-Chip Control is deactivated.

Note

- "NEXT PAGE" displays CANADIAN V-Chip setting menu. Not necessary except when viewing Canadian tapes or broadcasts.

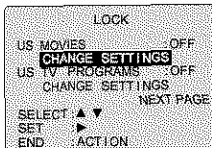
- 2) Press **▲▼** to select **CHANGE SETTINGS**.
- 2) Press **▶** to display screen.
- 

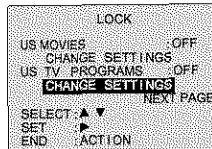
- 2) Press **▲▼** to select **CHANGE SETTINGS**.
- 2) Press **▶** to display screen.
- 

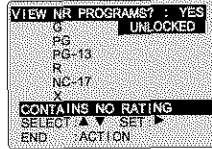
- 3) Press **▲▼** to select **VIEW NR PROGRAMS?**.
- 2) Press **▶** to set "YES" or "NO."
- 

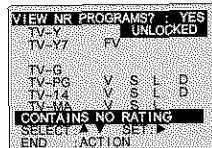
- 3) Press **▲▼** to select **VIEW NR PROGRAMS?**.
- 2) Press **▶** to set "YES" or "NO."
- 

NR (Not Rated) PROGRAMS

Some movies, such as old movies or foreign movies usually have no ratings.

NR (Not Rated) PROGRAMS

Some TV shows, such as news, sports, weather, bulletins, emergency information usually have no ratings.

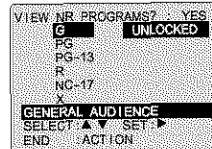
- 4) Press **▲▼** to select and **▶** to set ratings to be blocked.
- (See ratings chart next page.)
- 

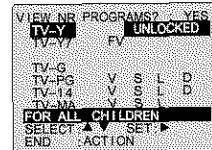
- 4) Press **▲▼** to select and **▶** to set ratings to be blocked.
- (See ratings charts next page.)
- 

Note

- You may select from standard TV ratings (chart 1), or customize to a specific content rating (chart 2).

- Ratings highlighted in Green will be blocked. Ratings in white letters will not be blocked.

- 5) Press **ACTION** to redisplay LOCK menu and continue with US TV PROGRAMS Ratings Setup (this page).
- Or, press **ACTION** four times to exit.

- 5) Press **ACTION** four times to exit this mode.

Process of V-Chip Control Feature

Enter Code → Setup → Blocking

Blocking Message

<When V-Chip Control is activated>

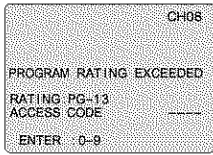

• If a program or movie exceeds the ratings you have set, a message will appear on a black background and sound is muted.

To View a Blocked Program / Movie [Temporarily Deactivate V-Chip Control]

Enter your secret code (ACCESS CODE) in the Blocking Message screen.

• V-Chip Control is reactivated when power is turned off or power failure occurs.

[Deactivate V-Chip Control]

Enter your secret code (steps 1-4 page 29). Then, set US MOVIES and/or US TV PROGRAMS to "OFF" using ▲▼ and ► keys. (Ratings set on page 30 is retained and will be in effect when V-Chip Control is activated again.)

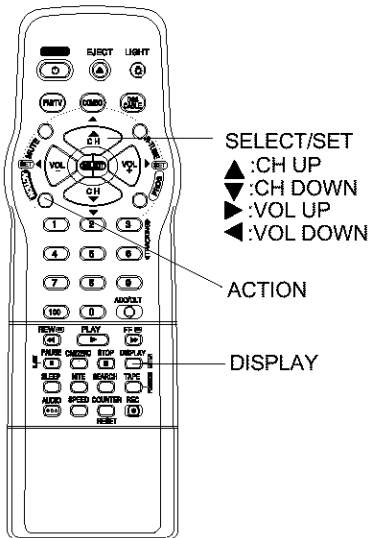

Model PV-C2062 remote shown.

US MOVIES RATINGS

| | |
|--------------|----------------------------------------------------------------------------------------|
| G | GENERAL AUDIENCE: All ages admitted. |
| PG | PARENTAL GUIDANCE: Some material may not be suitable for children. |
| PG-13 | PARENTS CAUTIONED: Some material may be inappropriate for children under 13. |
| R | RESTRICTED: Children under 17 must be accompanied by a parent or adult. |
| NC-17 | OVER AGE 17 ONLY: No one 17 and under admitted. |
| X | ADULTS ONLY: |

US TV PROGRAMS RATINGS: Chart 1

| | |
|--------------|----------------------------------------------------------------------------------------------------------------------------------------|
| TV-Y | FOR ALL CHILDREN: Content specifically geared to young viewers ages 2-6. |
| TV-Y7 | FOR AGE 7 AND OLDER: May contain mild physical or comedic violence which may frighten children under 7. |
| TV-G | GENERAL AUDIENCE: Contains little or no violence, strong language, or sexual dialogue or situations. |
| TV-PG | PARENTAL GUIDANCE: May contain infrequent coarse language, limited violence, some suggestive sexual dialogue and situations. |
| TV-14 | PARENTS CAUTIONED: May contain sophisticated themes, sexual situations, strong language, and more intense violence. |
| TV-MA | MATURE AUDIENCE: May contain mature themes, profane language, graphic violence, and sexual situations. |

Advanced Operation

US TV PROGRAMS RATINGS: Chart 2

| | |
|-----------|------------------------------|
| FV | Fantasy Violence |
| V | Violence |
| S | Sexual Situations |
| L | Adult Language |
| D | Sexually Suggestive Dialogue |

Cable Box Universal Remote Control Feature

Universal Remote Control is...

The Remote Control may be set up to control some basic DSS or Cable box functions.

The Universal Remote Control Setup

1 Find your DSS box or Cable box Brand Code Number from one of the charts on the next page.

2 Setup remote.
Hold down DSS CABLE and press number keys to enter code.

- For code 100 or greater, first press 100 key, then the remaining digits. E.g. for 102, press 100, then press 0, and then press 2.

3 Confirm code entry.
Press POWER* to turn selected unit ON or OFF.

- See below for controllable functions in each mode.

Notes

- Please repeat the Universal Remote Control Setup after replacing remote control batteries.
- The remote control will not operate all DSS receivers or Cable Boxes made by the manufacturers listed. If you get no results, your particular brand cannot be controlled.

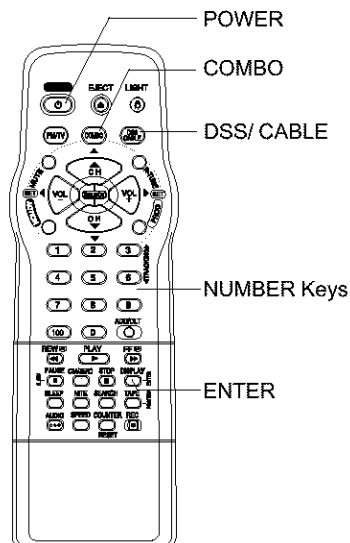

Model PV-C2062 remote shown.

Using the Universal Remote Control

Once the remote control has been properly set up, you can select COMBO, DSS or CABLE mode depending on which functions you wish to control. (See below.)

Press COMBO or DSS CABLE on the remote control to select the desired mode. (See below for buttons available in each mode.)

Set to COMBO:

- All TV and VCR functions.

Set to DSS CABLE:

- Basic VCR functions, e.g. PLAY, REC, etc.
- CABLE/DSS functions, e.g. POWER, ENTER, number keys (except 100 key), CH UP/DOWN.

DSS Brand Code Numbers

| | | | | | |
|-------------------------|----|-------------------------|----|------------|---------|
| Toshiba | 92 | Magnavox/Uniden 2 | 95 | Sony | 98, 105 |
| Hitachi/Hughes | 93 | Panasonic | 96 | | |
| Magnavox/Uniden 1 | 94 | RCA | 97 | | |

Cable Box Brand Code Numbers

| | | | | | |
|------------------------|---------------------------------------------------------------------------|--------------------------|--------------------------------------------|---------------------------|-------------------------------------------------|
| Archer | 05, 06, 01, 44, 63, 91, 126 | Matsushita | 16, 17, 97, 109 | Sheritech | 27 |
| Cabletenna ... | 01, 44, 63, 91, 126 | Movietime | 32, 39, 42, 44, 126, 38, 40 | Signal | 26, 112 |
| Cableview | 63, 44, 42, 30, 52, 04, 124, 126 | NEC | 38, 40, 32 | SL Marx | 32, 40, 42, 06, 43, 44, 52, 63, 126 |
| Century .. | 51, 44, 59, 75, 126 | NOVAVISION | 08, 09, 61, 53, 87 | Sprucer | 16, 17, 97, 109 |
| Citizen | 63, 44, 42, 30, 52, 04, 124, 126 | NSC | 38, 40, 32 | Standard Components | 32, 39, 42, 44, 126 |
| Curtis | 08, 09, 61, 53, 87 | Oak | 46, 11, 129 | Stargate | 32, 40, 63, 44, 42, 30, 52, 04, 06, 124, 126 |
| Diamond .. | 01, 44, 63, 91, 126 | Oak Sigma | 46, 11, 129 | Sylvania | 19 |
| Drake | 67 | Panasonic | 16, 17, 97, 109 | Teknika | 74 |
| Eagle | 13, 22, 58, 62, 20, 40, 26, 107 | Phillips | 07, 13, 20, 23, 24, 50, 128, 129 | Telecaption | 77, 127 |
| Eastern | 28, 130 | Pioneer | 05, 06 | Televue | 32, 40, 42, 06 |
| GC Brand | 63, 44, 42, 30, 52, 04, 124, 126 | Pulsar | 63, 44, 42, 30, 52, 04, 124, 126 | Texscan | 18, 19 |
| Gemini | 04, 124 | Quest | 05, 06 | Tocom .. | 33, 34, 01, 42, 66, 91 |
| General Electric | 57, 01 | Radio Shack | 51, 44, 59, 75, 126 | Toshiba | 36 |
| General Instruments .. | 01, 02, 03, 04, 34, 55, 83, 106, 65, 67, 68, 115, 117, 118, 124, 91 | RCA | 16, 17, 97, 109 | Uniden Satellite | 65 |
| Hamlin .. | 14, 15, 28, 41, 102, 103, 104, 108, 130 | Realistic ... | 51, 44, 59, 75, 126 | Unika | 01, 44, 63, 91, 126 |
| Hitachi | 31 | Recoton ... | 51, 44, 59, 75, 126 | Universal | 42, 43, 44, 52, 63, 126 |
| Jasco | 04, 124 | Regal | 14, 15, 28, 41, 102, 103, 104, 108, 130 | Videoway | 07, 23, 50, 129 |
| Jerrold | 01, 02, 03, 04, 34, 55, 83, 106, 65, 67, 68, 115, 117, 118, 124, 91 | Regency | 28, 130 | Vid Tech | 64 |
| Macom | 31 | Rembrandt | 01, 32, 39, 42, 44, 63, 126 | Vidtek | 64 |
| Magnavox | 26, 112 | Salora | 68 | Viewstar | 13, 22, 58, 62, 20, 40, 26, 107 |
| | | Samsung ... | 05, 32, 40, 42, 06 | Zenith | 07, 23, 50, 129 |
| | | Scientific Atlanta | 08, 09, 61, 53, 87 | | |

Notes

- In DSS or CABLE mode, it may be necessary to press ENTER after pressing number keys for channel selection.
- In DSS or CABLE mode, POWER, CH Up/Down, number Keys, ACTION, PROG, DISPLAY, SEARCH, R-TUNE, FM/TV, or ADD/DLT are not available. Press COMBO to use these functions.
- Depending on your DSS receiver or Cable box brand, some of the functions listed may not be remote controllable.
- Some DSS receiver or Cable box brands require you to turn on the power manually.
- Due to changes in infra-red commands used by manufacturers, some brands have several codes. If your unit does not respond to the first code, please try the next one.

On-Screen Display (OSD)

VCR Status & Clock Display

Press **DISPLAY**

to display or remove the overlay.

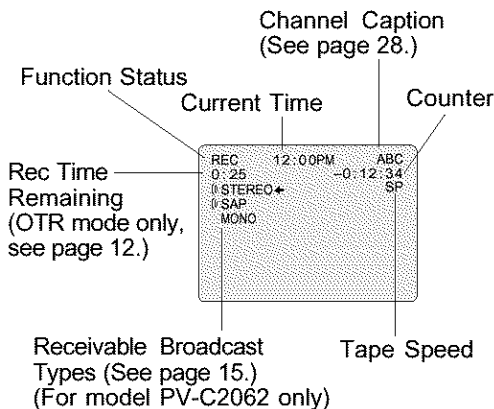

Blue Screen Display

Whenever a blank section of a tape comes up in Play mode, or when the selected channel has no broadcast signal with the Weak Signal Display set to "OFF" (see page 27), the screen will turn solid blue.

Channel & Function Display

When a function button is pressed (PLAY, FF, etc.) or you change channels, the unit mode or channel number will be displayed. (Some station names may also appear if Channel Caption is set. See page 28.)

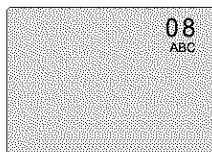

Warning and Instruction Displays

These displays will alert you to a missed operation or provide further instructions.

| OSD | Caution | Page |
|-----------------------------------------------------------------------------------------------------|-------------------------------------------------------------------------------------------------------------------------------------------|--------|
| PLEASE SET CLOCK BEFORE PROGRAMMING | • If you attempt to set or review a Timer Recording, or set the On-Timer and the Clock is not set... | 8 - 11 |
| CHECK CASSETTE RECORD TAB | • If you press REC, and a cassette is inserted with no record tab... | 3, 12 |
| TO CANCEL TIMER REC HOLD DOWN STOP KEY FOR APPROX 3 SEC | • If you press STOP during a Timer Recording... | 23 |
| NO CASSETTE PLEASE INSERT A CASSETTE | • If you press PLAY, FF, REW, or REC without a cassette inserted... | 12 |
| PLEASE PREPARE FOR TIMER REC | • If the unit is not in Stop mode or a cassette with record tab is not inserted two minutes before a Timer Recording is about to begin... | 22, 23 |
| VIDEO HEADS MAY NEED CLEANING PLEASE INSERT HEAD CLEANING CASSETTE OR REFER TO MANUAL END: PLAY KEY | • If head cleaning becomes necessary while playing back a tape... | 4 |
| VCR LOCK ACTIVATED | • If you press a function button other than STOP/EJECT or POWER while the unit is in VCR Lock mode... | 27 |

Before Requesting Service

Check the following points once again if you are having trouble with your unit.

| Power | Correction |
|------------------------------------------------------------------------------------------------------------------------------------------------------------------------------------------------------------------------------------------------------------------------------------------------------------------------------|------------------------------------------------------------------------------------------------------------------------------------------------------------------------------------------------------------------------------------------------------------------------------------------------------------------------------------------------------------------------------------------------------------------------------------------------------------------------------------------------------------------------------------------------------------------------|
| No power... | <ul style="list-style-type: none">• Completely insert Power Plug into an AC outlet.• Set POWER button to ON. |
| Monitor | Correction |
| No picture or sound... | <ul style="list-style-type: none">• Make sure your antenna system (TV or CABLE), is correctly set. (P. 8)• Completely insert Power Plug into an AC outlet.• Set POWER button to ON. |
| Poor picture with normal sound... | <ul style="list-style-type: none">• Adjust BRIGHTNESS, SHARPNESS, and PICTURE controls in the SET UP TV menu. (P. 21) |
| Poor sound with normal picture... | <ul style="list-style-type: none">• Adjust VOLUME control. (P. 14) |
| Poor TV reception... | <ul style="list-style-type: none">• Adjust SHARPNESS and PICTURE controls in the SET UP TV menu. (P. 21) |
| No color or poor color... | <ul style="list-style-type: none">• Adjust TINT and COLOR controls in the SET UP TV menu. (P. 21) |
| Ghost (multiple) images... | <ul style="list-style-type: none">• Install a directional antenna. |
| TV programs cannot be watched... | <ul style="list-style-type: none">• Make sure the selected channel is in unit's memory. (P. 10, 11) |
| Channel cannot be selected... | <ul style="list-style-type: none">• Only the channel being recorded can be viewed on this unit. |
| VCR | Correction |
| TV program cannot be recorded... | <ul style="list-style-type: none">• Make sure your antenna system (TV or CABLE), is correctly set. (P. 8)• Make sure cassette record tab is intact. (P. 3)• Check that clock is set to current time and date. |
| Timer recording cannot be performed... | <ul style="list-style-type: none">• Make sure DSS/CABLE box (if used) is left on and tuned to channel to be recorded.• Set recording Start/Stop times correctly. (P. 22-23)• Timer recording may not be performed or continued if a power interruption of more than 1 minute occurs before or during a Timer recording even after power is restored. |
| No playback picture, or the playback picture is noisy or contains streaks... VCR cannot be controlled... | <ul style="list-style-type: none">• Adjust TRACKING control in either direction. (P. 4)• Try Head Cleaning. (P. 4)• Make sure VCR LOCK is set to off. (P. 27)• Make sure unit is not in a Timer Record operation. |
| Remote Control | Correction |
| Unit cannot be controlled... | <ul style="list-style-type: none">• Aim remote at remote sensor on unit (P. 7) so that signal is unobstructed.• Inspect the remote batteries. (P. 3)• Make sure VCR LOCK is set to off. (P. 27)• Exposing unit remote sensor to direct fluorescent or outdoor light may cause signal interference.• Check remote batteries. |
| ACTION, PROG and FM/TV buttons cannot be selected... | |
| Miscellaneous | Correction |
| Video cassette cannot be inserted... Video cassette cannot be removed... Tape cannot be ejected or inserted... Video cassette ejects when a recording is started, or the power is turned off for timer recording... In Stop mode, the VCR motor (CYLINDER) continues to rotate... VCR cannot be controlled... | <ul style="list-style-type: none">• Insert the cassette window side up; record tab facing you.• Completely insert Power Plug into an AC outlet.• Try ejecting or inserting the tape again after turning POWER off, then back on.• Make sure cassette record tab is intact. (P. 3) • To enable Quick Play mechanism, the VCR cylinder will rotate for about 3 minutes. This reduces response time from Stop to Play mode and from Play to Rewind Search mode.• Make sure VCR LOCK is set to off. (P. 27) |

If you cannot resolve the problem, please call the Customer Satisfaction Center for product assistance at 1-800-211-PANA(7262).

To locate an authorized servicenter call toll free 1-800-211-PANA(7262) or send e-mail to : consumerproducts@panasonic.com.

Servicecenter List

For Product Information, Operating Assistance, Literature Request, Dealer Locations, and all Customer Service inquiries please contact:
1-800-211-PANA(7262), Monday-Friday 9am-9pm Saturday-Sunday 9am-7pm, EST.
or send e-mail : consumerproducts@panasonic.com

Web Site: <http://www.panasonic.com>

You can purchase parts, accessories or locate your nearest servicecenter by visiting our Web Site.

Accessory Purchases:

1-800-332-5368 (Customer Orders Only)

Panasonic Services Company 20421 84th Avenue South, Kent, WA 98032
(6 am to 5 pm Monday - Friday; 6 am to 10:30 am Saturday; PST)
(Visa, Master Card, Discover Card, American Express, Check)

Factory Servicecenter Locations

CALIFORNIA

6550 Katella Avenue
Cypress, CA 90630
800 Dubuque Avenue
S. San Francisco,
CA 94080

3878 Ruffin Road
Suite A
San Diego, CA 92123

FLORIDA

3700 North 29th Avenue
Suite 102
Hollywood, FL 33020

GEORGIA

8655 Roswell Road
Suite 100
Atlanta, GA 30350

ILLINOIS

1709 North Randall Road
Elgin, IL 60123

MASSACHUSETTS

60 Glacier Drive,
Suite G
Westwood, MA 02090

MINNESOTA

7850-12th Avenue South
Airport Business Center
Bloomington, MN 55425

OHIO

2236 Waycross Road
Civic Center Plaza
Forest Park, OH 45240

PENNSYLVANIA

2221 Cabot Blvd. West
Suite B
Langhorne, PA 19047

TEXAS

13615 Welch Road
Suite 101
Farmers Branch,
TX 75244

WASHINGTON

20425-84th Avenue
South
Kent, WA 98032

HAWAII

99-859 Iwaiwa Street
Aiea, Hawaii 96701
Phone (808) 488-1996
Fax (808) 486-4369

Service in Puerto Rico

Matsushita Electric of Puerto Rico, Inc. Panasonic Sales Company/ Factory Servicecenter:
Ave. 65 de Infanteria. Km. 9.5 San Gabriel Industrial Park Carolina, Puerto Rico 00985
Phone (787) 750-4300 Fax (787) 768-2910

As of June 2001

LIMITED WARRANTY

Panasonic Consumer Electronics Company,
Division of Matsushita Electric Corporation
of America, One Panasonic Way
Secaucus, New Jersey 07094

Panasonic Sales Company,
Division of Matsushita Electric of Puerto Rico, Inc.
AVE. 65 de Infantería, Km. 9.5 San Gabriel
Industrial Park Carolina, Puerto Rico 00985

PANASONIC/QUASAR Video Products Limited Warranty

Panasonic Consumer Electronics Company or Panasonic Sales Company (collectively referred to as "the Warrantor") will repair or replace this product with new or refurbished parts or equivalent product, free of charge, in the USA or Puerto Rico, in the event of a defect in materials or workmanship as follows (all time periods commence from the date of the original purchase):

| PRODUCT | PARTS | LABOR | SERVICE | CONTACT NUMBER |
|---------------------------------------------|----------------------------------------------------------------------------------|----------------------------------------------------------------|--------------------------------------------------------------------------------|----------------------|
| CAMCORDER | ONE (1) YEAR, EXCEPT CCD IMAGE SENSOR CCD IMAGE SENSOR - SIX (6) MONTHS | NINETY (90) DAYS | Carry-In or Mail-In | 1-800-211-PANA(7262) |
| DVD/VCR DECK | ONE (1) YEAR | NINETY (90) DAYS | Carry-In or Mail-In | 1-800-211-PANA(7262) |
| DIGITAL STILL CAMERA | ONE (1) YEAR, EXCEPT CCD IMAGE SENSOR CCD IMAGE SENSOR - SIX (6) MONTHS | NINETY (90) DAYS NINETY (90) DAYS | Carry-In or Mail-In | 1-800-272-7033 |
| AV MIXER | ONE (1) YEAR | NINETY (90) DAYS | Carry-In or Mail-In | 1-800-211-PANA(7262) |
| TV/VCR, TV/DVD TV/DVD/VCR COMBINATION | ONE (1) YEAR, EXCEPT CRT CRT - TWO (2) YEARS | NINETY (90) DAYS NINETY (90) DAYS CRT - NINETY (90) DAYS | Carry-In: 21" CRT and Smaller In-Home or Carry-In: 22" CRT and Larger | 1-800-211-PANA(7262) |
| TV/HDR COMBINATION | ONE (1) YEAR, EXCEPT CRT CRT - TWO (2) YEARS | NINETY (90) DAYS CRT - NINETY (90) DAYS | In-Home or Carry-In | 1-888-843-9788 |

Batteries (if included) - New rechargeable batteries in exchange for defective rechargeable batteries for ten (10) days. Non-rechargeable batteries are not warranted.

Tape (if included) - New video cassette tape in exchange for a defective video cassette tape for five (5) days.

Memory cards (if included) - Exchange defective item for new one for ninety (90) days.

In-home, carry-in or mail-in service, as applicable, in the USA can be obtained during the warranty period by contacting a Panasonic Services Company (PASC) Factory Servicenter listed in the Servicenter Directory. Or call toll free contact number listed above, to locate an authorized PASC Servicenter. Carry-in or mail-in service in Puerto Rico can be obtained during the warranty period by calling the Panasonic Sales Company telephone number listed in the Servicenter Directory.

This warranty is extended only to the original purchaser. A purchase receipt or other proof of the date of the original purchase is required before warranty service is rendered.

This warranty only covers failures due to defects in materials and workmanship, which occur during normal use and does not cover normal maintenance, including, but not limited to, video and audio head cleaning. The warranty does not cover damage which occurs in shipment, or failures which are caused by products not supplied by the warrantor, or failures which result from accident, misuse, abuse, neglect, mishandling, misapplication, alteration, modification, faulty installation, set-up adjustments, improper antenna, inadequate signal pickup, misadjustment of consumer controls, improper operation, power line surge, improper voltage supply, lightning damage, commercial use such as hotel, office, restaurant, or other business or rental use of the product, or service by anyone other than a PASC Factory Servicenter or a PASC authorized Servicenter, or damage that is attributable to acts of God.

LIMITS AND EXCLUSIONS

There are no express warranties except as listed above.

THE WARRANTOR SHALL NOT BE LIABLE FOR INCIDENTAL OR CONSEQUENTIAL DAMAGES (INCLUDING, WITHOUT LIMITATION, DAMAGE TO RECORDING MEDIA) RESULTING FROM THE USE OF THIS PRODUCTS, OR ARISING OUT OF ANY BREACH OF THE WARRANTY. ALL EXPRESS AND IMPLIED WARRANTIES, INCLUDING THE WARRANTIES OF MERCHANTABILITY AND FITNESS FOR PARTICULAR PURPOSE, ARE LIMITED TO THE APPLICABLE WARRANTY PERIOD SET FORTH ABOVE. Some states do not allow the exclusion or limitation of incidental or consequential damages, or limitations on how long an implied warranty lasts, so the above exclusions or limitations may not apply to you. This warranty gives you specific legal rights and you may also have other rights, which vary, from state to state. If a problem with this product develops during or after the warranty period, you may contact your dealer or Servicenter. If the problem is not handled to your satisfaction, then write to the Consumer Affairs Department at the Panasonic Consumer Electronics Company address above.

SERVICE CALLS WHICH DO NOT INVOLVE DEFECTIVE MATERIALS OR WORKMANSHIP AS DETERMINED BY THE WARRANTOR, IN ITS SOLE DISCRETION, ARE NOT COVERED. COSTS OF SUCH SERVICE CALLS ARE THE RESPONSIBILITY OF THE PURCHASER.

warvid 02/12/2001

Connexiones/Configurcion Inicial

Conecte por favor todas las conexiones del cable o de la antena antes de turing potencia.

Conectando

Para Ant./Cable

Conecte Ant./Cable a la entrada de antena de la TV (VHF/UHF).

Para Sistema Digital de Satelite (DSS)/

Convertidor de cable

Conecte la salida del convertidor de cable la "VHF/UHF" con el RF cable.

Ajuste Manual del Reloj

Si el ajuste automático del reloj no se ha completado, ajuste el reloj manualmente de la siguiente manera:

- 1) Presione la tecla ACTION en el control remoto para visualizar la pantalla del menú RELOJ.
- 2) Presione ▲▼ para seleccionar el mes y ► para ajustar. De la misma forma, seleccione y ajuste la fecha, año, hora y DST (Hora de Verano).
- 3) Presione dos veces la tecla ACTION para poner el RELOJ en marcha y salir.

Realizando Configuracion Inicial

- 1 Presione COMBO para modo del combo. Tape el cable electrico de la unidad en el enchufe de pared de la CA. POWER de la prensa en el telecontrol o la unidad. La unidad se adelanta y comienzo auto del canal y del reloj.

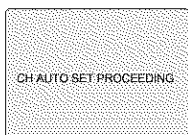

Si usa convertidor de cable, enciendala y seleccione el Servicio Publico de Canales de Television (PBS) en su horario de uso o tiempo de su zona. Si utiliza receptor DSS este debe de estar apagado.

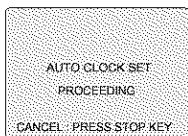

2



Selecciones se realizaran automaticamente cuando la configuracion termine, la pantalla siguiente aparecera.

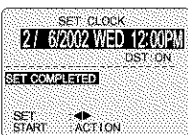

Si "AUTO CLOCK SET IS INCOMPLETE" aparece en pantalla, coloque el tiempo usando el procedimiento manual (MANUAL CLOCK SET), vealo enseguida..

Ajustar de nuevo el reloj

- 1 Presione ACTION para exhiba el menú.

2

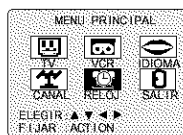

Presione ▲▼◀▶ para seleccionar "RELOJ". Presione ACTION.

3

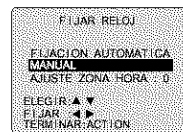

Presione ▲▼ para seleccionar "MANUAL" y luego presione ►.

4



Presione ▲▼ y ◀▶ para seleccionar y ajustar la hora y la fecha.

5

Presione ACTION dos veces para que el reloj comience a funcionar y salir desde este modo.

Operaciones básicas para la reproducción

- 1 Inserte un casete.**
 - El videograbador combinado se enciende automáticamente.
- 2 Presione PLAY.**
 - La reproducción comienza automáticamente si el casete no tiene la lengüeta para prevención de grabación.
 - Para encontrar una escena en particular Búsqueda hacia adelante => Presione FF Búsqueda hacia atrás => Presione REW
 - Para ver una imagen fija (congelada) => Presione PAUSE/SLOW
 - Para ver en cámara lenta => Mantenga pulsado el botón PAUSE/SLOW en el modo de imagen fija
 - Para ver imágenes cuadro a cuadro => Presione PAUSE/SLOW en el modo de imagen fija
 - Para parar => Presione STOP
 - Para rebobinar la cinta => Presione REW
 - Para hacer avanzar la cinta rápidamente => Presione FF
 - Para expulsar la cinta => Presione EJECT en el control remoto o STOP/EJECT en el videograbador combinado

Operaciones básicas para la grabación

- 1 Inserte un casete con la lengüeta para prevención de grabado.**
 - El videograbador combinado se enciende automáticamente.
- 2 Seleccione el canal.**

Presione CH ▲▼ o las teclas numéricas correspondiente.
- 3 Seleccione la velocidad de grabación.**

Presione SPEED.

 - SP = reproducción normal
 - LP = reproducción larga
 - SLP = reproducción super larga
 - La velocidad seleccionada debe aparecer en la pantalla.
- 4 Comience la grabación.**

Presione REC.

 - Para editar partes no deseadas de una grabación, presione PAUSE/SLOW para hacer una pausa durante la grabación.
 - No podrá ver otro canal durante la grabación.
 - Para parar => Presione STOP.
 - **El videograbador combinado deja de grabar a una hora prefijada.** (Grabación de un toque)
Presione REC repetidamente para ajustar la hora de grabación (30 min - 4 horas.)

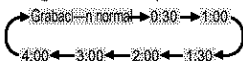

Grabación con temporizador

- 1 Exhiba FIJAR PROGRAMACION.**

Presione PROG.
- 2 Exhiba TEMPORIZADOR.**

1) Presione ▲▼ para seleccionar.

2) Presione ► para exhibir.

 - Si ya existe un programa en la memoria, presione ▲▼ y ► para seleccionar un número de programa sin usar.
- 3 Ajuste la fecha de grabación.**

1) Presione ▲▼ para seleccionar.

2) Presione ► ◀ para ajustar.

 - 1 - 31 = Grabación única
 - DIARIO = a la misma hora de lunes a viernes
 - SEMANAL = a la misma hora una vez a la semana

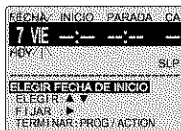

- 1 - 31 = Grabación única
- DIARIO = a la misma hora de lunes a viernes
- SEMANAL = a la misma hora una vez a la semana



Repita el paso 3 para ajustar: hora de comienzo, hora de parada, canal (o LINEA para una fuente exterior), velocidad (SP, LP, SLP)

- 4 Termine el programa.**

Presione PROG (o ACTION.)

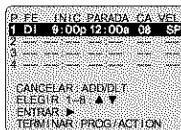

Para introducir más programas. presione ▲▼ y ► para seleccionar y ajustar el número de programa en blanco, y luego repita los pasos 3 y 4.

- 5 Salga de este modo.**

Presione PROG dos veces (o ACTION.)

 - Si está usando un decodificador de TV cable, asegúrese que se encuentra en el canal deseado y que la alimentación queda conectada para grabar con temporizador.
 - El indicador PROG TIMER se enciende en el videograbador combinado.

INDEX

| | | | | | |
|----------|--------------------------------------------|-----------|----------|-----------------------------------------|---------|
| A | Accessories | 3 | P | Phones | 14 |
| | Audio Mute | 14 | | Playback | 12 |
| | Auto Operation Functions | 25 | | Picture Adjustment | 21 |
| B | Batteries | 3 | | Program End Search | 24 |
| | Before Requesting Service | 35 | Q | Quality Picture | 4 |
| | Blocking Message | 31 | R | Rapid Tune | 14 |
| | Blue Screen Display | 34 | | Rec(ord) | 12 |
| C | Cable Box Universal Remote Feature | 32,33 | | Record/Playback Speed Settings | 4 |
| | Caption On Mute | 19 | | Remote Control Buttons | 6 |
| | Channel | 8 -13, 34 | | Remote Warning ON/OFF | 28 |
| | Channel Caption | 28 | | Repeat Play | 26 |
| | Clock | 10 | | Reset Language, Channels, Clock | 10 |
| | Closed Caption | 18 | | Reset unit | 9 |
| | Commercial Skip | 26 | | Reverse Search | 12 |
| | Connections | 8 | | Rewind | 12 |
| | Connections, DSS / Cable Box | 8 | S | Secret Code | 29 |
| | Connections, Antenna / Cable | 8 | | Servicenter List | 36 |
| | Copy Your Tapes (Dubbing) | 13 | | Sleep Timer | 17 |
| D | DST (Daylight Saving Time) | 4 | | Slow Motion | 12 |
| E | Eject tape | 12 | | Spanish Quick Use Guide | 38, 39 |
| F | Fast Forward | 12 | | Special VCR Features | 27, 28 |
| | FM Radio | 20 | | Specifications | 4 |
| | Forward Search | 12 | | Still Picture | 12 |
| | Frame by Frame Advance | 12 | | STOP | 12 |
| | Front Panel Indicators | 7 | T | Tape Erasure Prevention | 3 |
| | Function Display | 34 | | Tape Position Display | 25 |
| H | Head Cleaning | 4 | | Time Zone Adjust | 11 |
| I | Important Safeguards and Precautions | 2 | | Timer Program Review, Replace, Clear .. | 23 |
| | Index Search | 24 | | Timer Recording | 22 |
| | Initial Setup | 8 | | Timer Recording Cancellation | 23 |
| | Input Mode | 13 | | TV Operation | 14 |
| | Instant Alarm | 17 | | TV Timer Features | 16, 17 |
| L | Language | 10 | U | Unit, Front/Rear view | 7 |
| | Limited Warranty | 37 | | US MOVIES/TV PROGRAMS Ratings ... | 31 |
| | Location of Controls | 6 - 7 | V | VCR Lock | 27 |
| M | MTS Broadcast / TV Stereo System | 15 | | VCR Status & Clock Display | 34 |
| | (For Model PV-2062 only) | | | V-Chip Control Feature | 29 - 31 |
| N | NIGHT Mode | 14 | W | Warning and Instruction Displays | 34 |
| O | 100 Key | 14 | | Weak Signal Display ON/OFF | 27 |
| | One Touch Recording | 12 | Z | Zero Search | 26 |
| | ON-TIMER with Alarm | 16 | | | |

Panasonic Consumer Electronics Company,
Division of Matsushita Electric Corporation of America
One Panasonic Way Secaucus,
New Jersey 07094

Panasonic Sales Company ("PSC"),
Division of Matsushita Electric of Puerto Rico, Inc.
Ave. 65 de Infantería, Km. 9.5
San Gabriel Industrial Park, Carolina, Puerto Rico 00985



Printed in U.S.A
LSQT0582A
M0901-0