

Owner's Manual

CRAFTSMAN®

ALL-IN-ONE CUTTING TOOL

Model No.
183.172530

Important Safety Notice

▲ WARNING

Always have one hand firmly placed on the tool body while operating. Never operate the tool by holding only the tool handle.

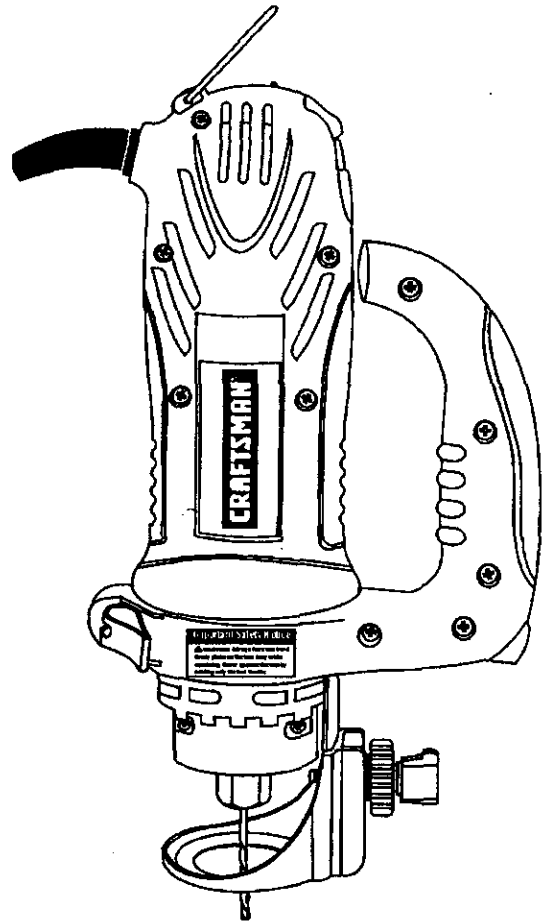

CAUTION:
Before using this Cutting Tool, read this manual and follow all its Safety Rules and Operating Instructions.

- Safety Instructions
- Accessories
- Assembly
- Operation
- Maintenance
- Parts List
- Espanol

Sears, Roebuck and Co., Hoffman Estates, IL 60179 USA
Part. No. 183172530001 Rev. 0 12/25/02

TABLE OF CONTENTS

SECTION	PAGE	SECTION	PAGE
Warranty	2	Carton Contents	6, 7
Product Specifications	2	Know Your Cutting Tool	8
Power Tool Safety	3	Assembly & Operation	9 - 13
Cutting Tool Safety	4	Maintenance	13
Electrical Requirements & Safety	5	Repair Parts	14 - 17
Accessories	6	Parts & Service Availability	18

WARRANTY

FULL ONE YEAR WARRANTY

If this Cutting Tool fails due to a defect in material or workmanship within one year of date of purchase, Sears will at its option repair or replace it free of charge.

Return this Cutting Tool to a Sears Service Center for repair, or to place of purchase for replacement.

This warranty gives you specific legal rights, and you may also have other rights which may vary from state to state.

Sears, Roebuck and Co., Dept. 817 WA, Hoffman Estates, IL 60179

WARNING

Some dust created by power sanding, sawing, grinding, drilling and other construction activities contains chemicals known (to the State of California) to cause cancer, birth defects or other reproductive harm. Some examples of these chemicals are:

- Lead from lead-based paints
- Crystalline silica from bricks, cement and other masonry products
- Arsenic and chromium from chemically treated lumber

Your risk from these exposures varies, depending on how often you do this type of work. To reduce your exposure to these chemicals, work in a well ventilated area and work with approved safety equipment such as those dust masks that are specially designed to filter out microscopic particles.

PRODUCT SPECIFICATIONS

Motor Rating	120V, 60Hz, AC	Motor Horsepower	3/4 HP (Maximum Developed)
Amperes	5.0 Amperes	Weight	1.7 kg
2 Speeds (no load)	20000 & 30000 RPM		

WARNING

To avoid electrical hazards, fire hazards or damage to the cutting tool, use proper circuit protection.

This cutting tool is wired at the factory for 110-120 Volt operation. It must be connected to a 110-120 Volt / 15 Ampere time delay fuse or circuit breaker. To avoid shock or fire, replace power cord immediately if it is worn, cut or damaged in any way.

Before using your cutting tool, it is critical that you read and understand these safety rules. Failure to follow these rules could result in serious injury to you or damage to the cutting tool.

POWER TOOL SAFETY

WARNING

Before using your cutting tool, it is critical that you read and understand these safety rules. Failure to follow these rules could result in serious injury to you or damage to the cutting tool.

Good safety practices are a combination of common sense, staying alert and understanding how to use your power tool. To avoid mistakes that could cause serious injury, do not plug in your cutting tool until you have read and understood the following safety rules:

1. **READ** and become familiar with this entire Owner's Manual. **LEARN** the tool's applications, limitations and possible hazards.
2.  **WARNING**
Look for this symbol that identifies important safety precautions. It means **CAUTION! BECOME ALERT! YOUR SAFETY IS INVOLVED!**
3. **KEEP GUARDS IN PLACE** and in working order.
4. **DO NOT USE IN A DANGEROUS ENVIRONMENT** such as damp or wet locations or exposure to rain. Keep work area well lighted.
5. **DO NOT** use power tools in the presence of flammable liquids or gases.
6. **KEEP WORK AREA CLEAN.** Cluttered areas and workbenches invite accidents.
7. **KEEP CHILDREN AWAY.** All visitors should be kept at a safe distance from the work area.
8. **DO NOT FORCE THE TOOL.** It will do the job better and safer at the rate for which it was designed.
9. **USE THE RIGHT TOOL.** Do not force the tool or attachment to do a job for which it is not designed.
10. **WEAR PROPER APPAREL. DO NOT** wear loose clothing, gloves, neckties, rings, bracelets or other jewelry that may get caught in moving parts. Non-slip footwear is recommended. Wear protective hair covering to contain long hair.
11. **WEAR A FACE MASK OR DUST MASK.** Sawing, cutting, drilling and sanding operations produce hazardous dust.
12. **DISCONNECT TOOLS FROM THE POWER SOURCE** before servicing and when changing accessories such as blades, bits, cutters, etc.
13. **REDUCE THE RISK OF UNINTENTIONAL STARTING.** Make sure the switch is in the "OFF" position before plugging into the power source.
14. **USE ONLY RECOMMENDED ACCESSORIES.** Consult the Owner's Manual for recommended accessories. The use of improper accessories may cause injury to you or damage to the tool.

15. **REMOVE ADJUSTING KEYS AND WRENCHES.** Form the habit of checking to see that keys and adjusting wrenches are removed from the tool before turning "ON".
16. **NEVER LEAVE TOOL RUNNING UNATTENDED. TURN THE POWER "OFF".** Do not leave the tool before it comes to a complete stop.
17. **NEVER STAND ON TOOL.** Serious injury could occur if the tool is tipped or if the cutting tool is unintentionally contacted.
18. **DO NOT OVER REACH.** Keep proper footing and balance at all times.
19. **MAINTAIN TOOLS WITH CARE.** Keep tools sharp and clean for most efficient and safest performance. Follow instructions for lubricating and changing accessories.
20. **CHECK FOR DAMAGED PARTS.** Before further use of the tool, a guard or other part that is damaged should be carefully checked to ensure it will operate properly and perform its intended function. Check for alignment of moving parts, binding of moving parts, mounting and any other conditions that may affect its safe operation. A guard or other part that is damaged should be properly repaired or replaced.
21. **MAKE WORKSHOP CHILD PROOF** with padlocks, master switches or by removing starter keys.
22. **DO NOT** operate the tool if you are under the influence of any drugs, alcohol or medication that could impair your ability to use the tool safely.
23. **USE DUST COLLECTION SYSTEM** wherever possible. Dust generated from certain materials can be hazardous to your health and in some cases, a fire hazard. Always operate the power tool in a well ventilated area with adequate dust removal.
24. **ALWAYS WEAR EYE PROTECTION.** Any power tool can throw foreign objects into your eyes which could cause permanent eye damage. **ALWAYS** wear safety goggles (not glasses) that comply with ANSI safety standard Z87.1. Everyday glasses have only impact resistant lenses. They **ARE NOT** safety glasses. Safety goggles are available at Sears.



ANSI safety standard Z87.1. Everyday glasses have only impact resistant lenses. They **ARE NOT** safety glasses. Safety goggles are available at Sears.

WARNING

Glasses or goggles not in compliance with ANSI Z87.1 could cause serious injury when they break.

SAVE THESE INSTRUCTIONS FOR REFERENCE

CUTTING TOOL SAFETY

▲ WARNING

For your safety, do not plug in your cutting tool or try to use any accessory until it is completely assembled and installed according to these instructions, and until you have read and understood this Owner's Manual.

Failure to follow these safety rules will result in risk of serious injury.

1. **WEAR EYE PROTECTION.** This high speed tool will throw particles from the workpiece during operation. Make sure safety glasses have side shields.
2. **USE FACE OR DUST MASK** along with safety goggles if cutting or routing operation is dusty. Make sure work area is well ventilated.
3. **USE HEARING PROTECTION,** particularly during extended periods of operation.
4. **NEVER USE DULL OR DAMAGED BITS.** Damaged bits can break without warning. Dull bits may overload the motor, cut slowly and are difficult to control. They will also overheat and possibly break.
5. **ALWAYS MAKE SURE THE WORKPIECE IS FREE OF NAILS AND OTHER FOREIGN OBJECTS.** If the bit strikes a nail it will jump sideways and possibly break.
6. **DO NOT USE THIS TOOL FOR DRILLING HOLES.** It is NOT intended to be used as a drill.
7. **ALLOW CLEARANCE UNDER WORKPIECE** for bit to travel. Never place workpiece on hard surfaces such as concrete etc. The bit may jump or break when contacting a surface other than the one being cut.
8. **ALWAYS SET THE DEPTH GUIDE TO THE APPROPRIATE DEPTH.** Use tool with the depth guide flat against the work surface for better control of the tool.
9. **NEVER USE THE TOOL WITHOUT THE SOLE PLATE, PRECISION HANDLE OR ROUTER BASE** attached and appropriately adjusted.
10. **ALWAYS CLAMP WORKPIECE TO HOLD IT STEADY WHEN CUTTING.** This will free both hands for operating the tool.
11. **NEVER HOLD THE WORKPIECE IN ONE HAND** while operating the tool with the other hand.
12. **NEVER PLACE HANDS IN THE PATH OF THE CUTTER AND UNDER THE WORKPIECE.**
13. **NEVER START THE TOOL WHEN THE BIT IS TOUCHING THE WORKPIECE.** The bit may catch the workpiece causing loss of control.
14. **ALWAYS HOLD THE TOOL WITH TWO HANDS DURING START-UP AND OPERATION.** When starting, motor torque will cause the tool to twist.
15. **TURN OFF ALL CIRCUIT BREAKERS AND REMOVE ALL FUSES** in the work area when cutting into walls or blind areas.
16. **ALWAYS HOLD THE TOOL BY THE INSULATED GRIPPING SURFACES ON THE BODY OF THE TOOL** where there is any possibility of the cutting bit contacting hidden electrical wires or the cord of the tool. Contact with "live" wires will make exposed metal parts of the tool "live" causing an electrical shock to the operator.
17. **WHEN CUTTING DRYWALL ELECTRICAL OUTLET OPENINGS** using the outlet as a guide, always cut in a counter clockwise direction. The natural tendency of the tool to pull to the left will cause a "hugging" action toward the outlet box, resulting in a neater cut.
18. **NEVER LAY THE TOOL DOWN UNTIL THE CUTTING BIT COMES TO A COMPLETE STOP.** A spinning bit can come in contact with the surface and pull it out of your control.
19. **NEVER TOUCH THE CUTTING BIT IMMEDIATELY AFTER USE.** The bit will be too hot to be handled with bare hands and will burn your fingers.
20. **ALWAYS RE-TIGHTEN COLLET AND ALL ADJUSTMENTS** before starting the tool after a cutting bit or accessory has been changed. Loose bits and adjustments can cause unexpected shifting of the tool resulting in loss of control and injury from the bit or cutting tool being thrown.

SAVE THESE INSTRUCTIONS FOR REFERENCE

ELECTRICAL REQUIREMENTS & SAFETY

DOUBLE INSULATION

This cutting tool is double insulated to protect you from electrical shock.

⚠ WARNING

Double insulated tools are equipped with a polarized plug (one blade is wider than the other). This plug will fit into a polarized outlet only one way. If the plug does not fit fully into the outlet, reverse the plug. If it still does not fit, contact a qualified electrician to install a polarized outlet. Do not alter the plug in any way. Double insulation eliminates the need for the three wire grounded power cord and grounded power supply system.

Avoid body contact with grounded surfaces such as pipes, radiators, ranges and refrigerators. There is an increased risk of electric shock if your body is grounded.

Do not expose power tools to rain or wet conditions. Water entering a power tool will increase the risk of electric shock.

Do not abuse the cord. Never use the cord to carry the tool or pull the plug from the outlet. Keep cord away from heat, oil, sharp edges and moving parts. Replace damaged cords immediately. Damaged cords increase the risk of electric shock.

When operating a power tool outdoors, use an outdoor extension cord marked "W-A" or "W". These cords are rated for outdoor use and reduce the risk of electric shock.

⚠ WARNING

Always make sure the receptacle is polarized. If you are not sure, have a qualified electrician check the receptacle.

GUIDELINES FOR EXTENSION CORDS

Make sure your extension cord is in good condition. When using an extension cord, be sure to use one heavy enough to carry the current the tool will draw. An undersized cord will cause a drop in line voltage resulting in loss of power and overheating. The table below shows the correct size to use according to cord length and nameplate ampere rating. If in doubt, use the next heavier gauge. The smaller the gauge number the heavier the cord.

Be sure your extension cord is properly wired and in good condition. Always replace a damaged extension cord or have it repaired by a qualified electrician before using it. Protect your extension cord from sharp objects, excessive heat and damp or wet areas.

Use a separate electrical circuit for your power tools. This circuit must not be less than 14 gauge wire and should be protected with either a 15 Ampere time delay fuse or circuit breaker. Before connecting the power tool to the power source, make sure the switch is in the OFF position and the power source is the same as indicated on the nameplate. Running at lower voltage will damage the motor.

⚠ WARNING

Repair or replace damaged or worn extension cords immediately.

Select the appropriate extension cord gauge and length using the chart below.

MINIMUM GAUGE (AWG) EXTENSION CORDS (120 Volt use only)					
Ampere Rating		Total length in feet			
More Than	Not More Than	25'	50'	100'	150'
0	6	18	16	16	14
6	10	18	16	14	12
10	12	16	16	14	12
12	16	14	12	Not Applicable	

⚠ WARNING

Keep the extension cord clear of the working area. Position the cord so it will not get caught on the workpiece, tools or any other obstructions while you are working with the power tool.

ACCESSORIES

AVAILABLE ACCESSORIES

▲ WARNING

Use only accessories recommended for this cutting tool. Follow instructions that accompany accessories. Use of improper accessories may cause injury to the operator or damage to the cutting tool.

Visit your **Sears Hardware Department** or see the **Sears Power and Hand Tool Catalog** for an assortment of accessories recommended for use with this cutting tool:

- Flex Drive
- Rip Guide
- Router
- Circle Cutter
- 1/8" Cutting Bits
- 1/8" Hobby Rotary Tool Accessories
 - Cutters
 - Polishers
 - Sanders
 - Grinders
- Most 1/4" Shank Router Bits

▲ WARNING

Use only accessories designed for this cutting tool to avoid severe injury or tool damage.

Do not use any accessory unless you have completely read the instructions or Owner's Manual for that accessory.

CARTON CONTENTS

UNPACKING AND CHECKING CARTON CONTENTS

▲ WARNING

If any part is missing or damaged, do not plug the cutting tool into the power source until the missing or damaged part is replaced and assembly is complete.

Carefully unpack the cutting tool and all its components. Compare against the "Cutting Tool Components" chart below.

NOTE: See Page 7 for illustration of components.

▲ WARNING

To avoid fire or toxic reaction, never use gasoline, naphtha, acetone, lacquer thinner or similar highly volatile solvents to clean the cutting tool.

CUTTING TOOL COMPONENTS		
KEY	DESCRIPTION	QTY
Cutting Tool Box		
A	Cutting Tool	1
B	Collet Wrench	1
C	Collet Wrench Holder	1
D	Owner's Manual	1
Accessory Box		
E	Precision Handle with Sole Plate	1
F	Freehand Sole Plate Attachment	1
G	1/8" Collet Sleeve	1
H	1/4" Collet Sleeve	1
I	Lateral Style Drywall Cutter	1
J	Wood / Plastic / Fiberglass Cutter	1

NOTE: The two most commonly used cutters are included with this tool (items I & J). It is important that you use the correct cutter to ensure the most efficient cutting action.

- Use cutter "I" with the finer spiral for cutting drywall.
- Use the general purpose cutter "J" with the coarser spiral for cutting materials such as wood, plastic and fiberglass.

CARTON CONTENTS

Cutting Tool Box

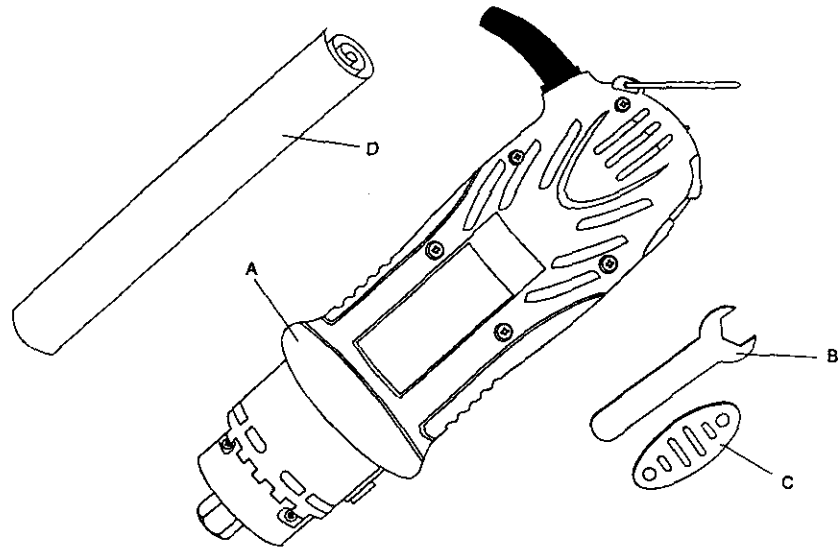

Accessory Box

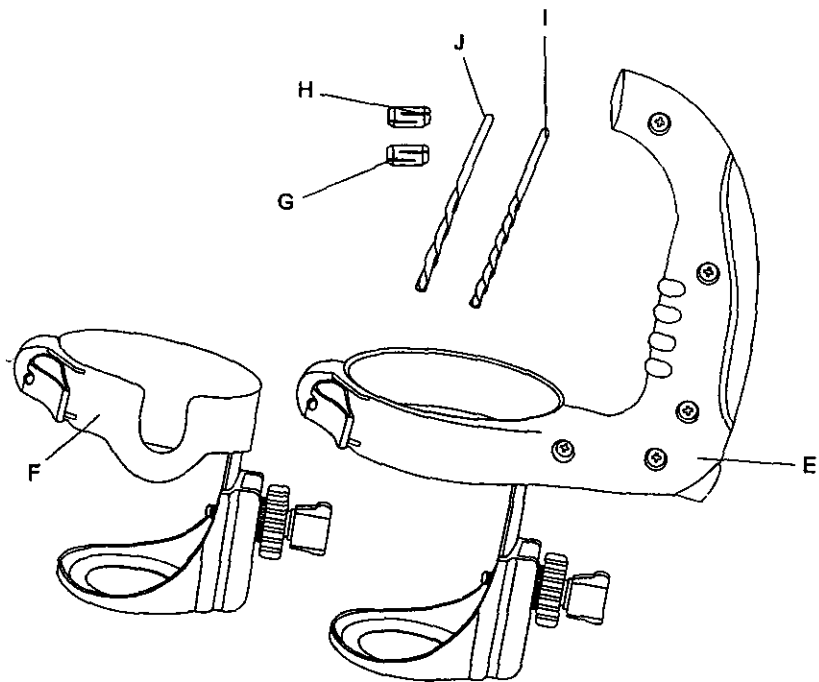

KNOW YOUR CUTTING TOOL

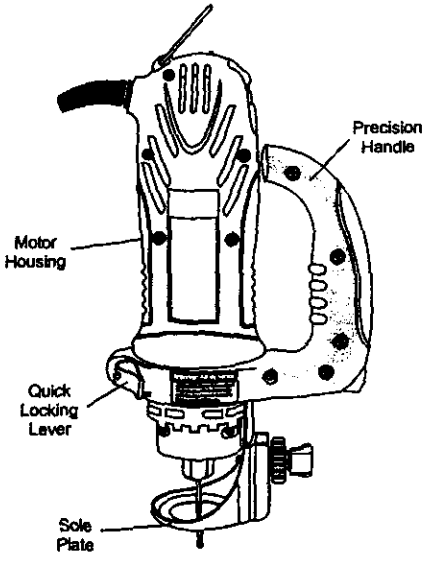
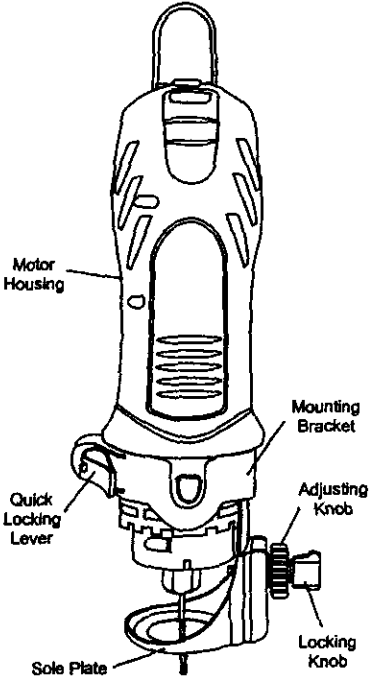

ASSEMBLY & OPERATION

⚠ WARNING

Remove the plug from the power source before assembly, changing accessories or cutters and making adjustments. This safety action will help prevent accidental starting of the tool which could result in serious injury.

ON / OFF & SPEED CONTROL SWITCHES

This cutting tool is equipped with a sliding ON / OFF switch (1) located on the side of the tool and a speed control switch (2) located on top of the tool (see Fig. 1).

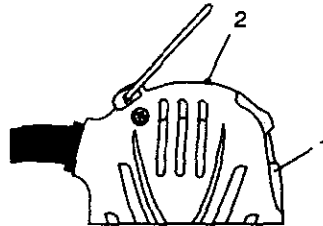

Fig. 1

1. To turn the tool ON, slide the switch (1) up.
2. To turn the tool OFF, slide the switch down.
3. To set speed to high speed, slide speed control switch (2) away from the ON / OFF switch.
4. To set the speed control switch to low speed, slide the speed control switch (2) toward the ON / OFF switch.

INSTALLING CUTTING BITS

⚠ WARNING

Cutting bit and router bit cutting surfaces are extremely sharp. Handle with caution.

To insert a cutting bit, use the collet wrench which is in the wrench holder attached to the power cord.

1. Depress the shaft locking button (1) and rotate the collet lock nut (2) clockwise with the other hand until the locking button drops into place, preventing the shaft from turning (see Fig. 2).
2. While continuing to hold the shaft locking button IN, use the collet wrench (3) to turn the collet nut counter clockwise. Loosen the collet nut two or three turns.
3. Remove bit if one is already installed in the tool.

INSTALLING CUTTING BITS – Cont'd

4. Insert new cutting bit (4) into the collet.

⚠ WARNING

Insert the bit all the way into the collet and then pull it back between $\frac{1}{16}$ " and $\frac{1}{8}$ ". This creates an air space between the motor shaft and the bit to help prevent overheating the bit.

Before tightening the collet on the bit, make sure the flutes (spiral portion) of the bit are completely visible outside the collet. Clamping the collet on the bit flutes will result in broken bits and possible injury.

5. When bit is properly placed in the collet, depress the shaft locking button and turn the collet nut clockwise by hand as far as possible.
6. Securely tighten collet nut using the wrench.

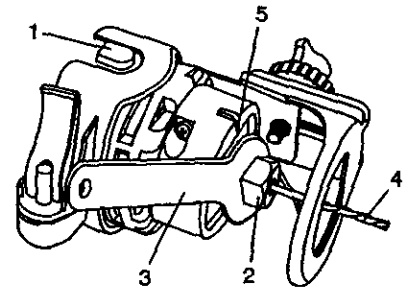

Fig. 2

WORK LIGHTS

The motor unit has two built-in work lights (5) (see Fig. 2). These work lights automatically light up when the motor switch is turned ON. Patterns or drawings in the immediate vicinity of the bit will be illuminated for better visibility and improved cutting accuracy.

SELECT APPROPRIATE MOTOR SPEED

Selecting the appropriate motor speed will ensure smoother, more efficient cutting action. Choose LOW speed for grinding, cutting plastics, polishing and when using wire or bristle brushes. Choose HIGH speed when cutting wood, using cut-off wheels and to reduce "chatter" that may develop when cutting some materials at LOW speed.

ASSEMBLY & OPERATION

CHANGING COLLET INSERT

The cutting bits for this tool are locked into place with a collet nut (1) and collet (see Fig. 3). The tool is assembled at the factory with NO collet installed. Both the 1/8" and 1/4" collets can be found in the carrying case front lid storage compartment. The 1/8" collet (2) is used for holding hobby tool accessory bits. The 1/4" collet (3) is supplied for holding SMALL router bits with a 1/4" shank.

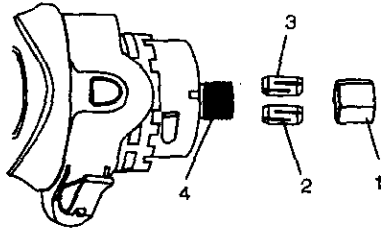

Fig. 3

To change from one collet size to the other:

1. Remove bit from the tool.
2. Continue turning the collet nut counter clockwise until it can be removed from the motor shaft (4).
3. Pull the collet out of the motor shaft and replace it with the other one.
NOTE: Each collet is the same on both ends, so either end can be inserted into the motor shaft.
4. Re-install the collet nut and slightly tighten it by hand.
5. Install the new bit as outlined in INSTALLING CUTTING BITS on Page 9.

NOTE: Tightening the collet nut without a bit in the collet will cause the collet hole to become smaller and make installing bits difficult. When storing the tool with no bit installed, leave collet nut loose.

FREEHAND SOLE PLATE

INSTALLING FREEHAND SOLE PLATE

The freehand sole plate is designed for basic freehand cutting with the cutting bit. It is ideally suited for cutting electrical outlet holes in drywall.

⚠ WARNING

Do NOT use the freehand sole plate with router bits. Limited control with this accessory could cause you to lose control and increase the chance of serious injury.

INSTALLING FREEHAND SOLE PLATE – cont'd

1. Slide freehand sole plate mounting bracket (1) onto the bottom of motor housing (2) until the slot in the bracket (3) lines up with the shaft locking button (4) in the motor housing.
NOTE: The mounting bracket must be pushed onto the motor housing as far as it will go.
2. Lock the sole plate to the motor housing by snapping the quick locking lever (5) firmly against the motor housing.

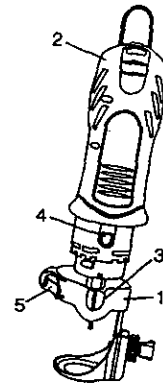

Fig. 4

ADJUSTING FREEHAND SOLE PLATE

1. Adjust freehand sole plate depth by loosening the depth gauge locking knob (6) and rotating the adjusting knob (7) to move the sole plate in or out as required (see Fig. 5).
NOTE: Set the depth gauge so the cutting bit protrudes beyond the sole plate 1/8" more than the thickness of the material being cut. For example, if you are cutting 5/8" drywall, the bit should protrude 3/4" beyond the sole plate.
2. Securely tighten depth gauge knob.
3. Before starting to cut you should re-check bit depth. Make sure sole plate is at right angles to the bit and securely tightened. Re-check the collet to make sure the bit is securely fastened.

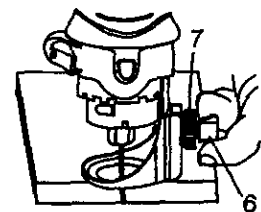

Fig. 5

ASSEMBLY & OPERATION

▲ WARNING

Have you read "POWER TOOL SAFETY", "CUTTING TOOL SAFETY" and "ELECTRICAL SAFETY" on pages 3, 4 and 5 of this Manual? If not, please do it now before you operate this cutting tool. Your safety depends on it!

Every time you use the cutting tool you should verify the following:

1. Cutting tool cord is not damaged.
2. Bit is correct type for the material being cut.
3. Bit is sharp, in good condition, properly installed and securely tightened.
4. Safety glasses and dust mask are being worn.

Failure to adhere to these safety rules can greatly increase your chances of injury.

PRACTICE CUTS USING FREEHAND SOLE PLATE

Before attempting to work on an actual project, take the time to make a few practice cuts with your cutting tool. Use some scraps of material that are the same material as used in your actual project.

1. Draw a pattern similar to your first project on a scrap piece of material.
2. Install freehand sole plate as shown in Fig. 4.
3. Install cutting bit in the collet as shown in Fig. 2.
4. Adjust depth of freehand sole plate as shown in Fig. 5.
5. Rest the edge of the sole plate on the workpiece with the bit at an angle of about 45° (see Fig. 6).
NOTE: DO NOT let the bit contact the workpiece until switch is turned ON and the tool is up to full speed.

▲ WARNING

Before turning the tool switch ON, make sure you hold the tool firmly with both hands. Starting torque will cause the tool to twist.

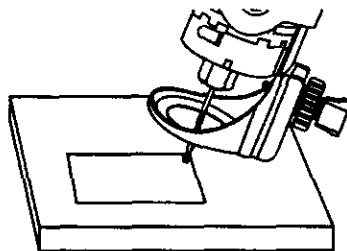

Fig. 6

PRACTICE CUTS USING FREEHAND SOLE PLATE

6. Set the speed control switch to the appropriate speed.
7. Turn the switch ON.
8. When the motor is up to full speed, slowly tip the tool to an upright position, letting the bit cut into the workpiece (see Fig. 7). Once the tool has reached the upright position and the bit has cut through the workpiece, slowly move the tool in a **clockwise** direction using slow steady pressure to make the cut. NOTE: Except for cutting around outlet boxes in drywall, always cut in a **clockwise** direction.
9. When cut is complete, turn the tool OFF, wait until it comes to a complete stop and remove it from the workpiece.

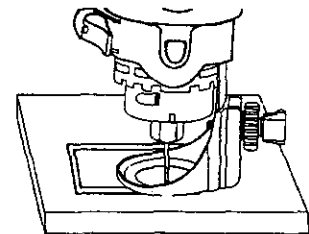

Fig. 7

▲ DANGER

Do not attempt cutting around outlet boxes in drywall until:

1. All electricity in the vicinity of electric wires has been disconnected by either turning the breaker OFF or removing the fuses.
2. You have read the instructions on the following page entitled "CUTTING OUTLET OPENINGS IN DRYWALL".

CUTTING TIPS

The rotating cutting action of the bit will cause a slight pull to the left when cutting. Natural variations in the structure of wood will cause the bit to "wander". This tendency will be magnified when applying too much pressure to the bit. Slower cutting gives you better control. Excessive pressure or fast cutting will increase bit temperature and shorten the life of the bit.

When cutting a hole in a vertical surface, avoid ending the cut at the bottom of the hole. Always start and end the cut at the "top" so the cut-out part will not drop onto the rotating bit. Always turn the tool OFF before removing it from the workpiece.

ASSEMBLY & OPERATION

CUTTING OUTLET OPENINGS IN DRYWALL

▲ DANGER

Do not attempt to use this tool to make cut-outs around any fixture or opening which has live electrical wires or on any wall which may have electrical wiring behind it. If a live wire is contacted, the bit could conduct the electric current to the tool, creating an electrocution hazard for the operator. Turn OFF breakers or remove fuses to disconnect the electric circuit in the area of work. Always hold the tool by its insulated housing when working in areas where there is a possibility of contacting electric wires. Always wear eye protection when operating this tool.

1. Before installing drywall, push the electrical wires to the back of the box as far as possible so they will not be cut by the bit when cutting the opening.
2. Before fastening the drywall sheet over the electrical box, mark the sheet as close as possible to the center of the box opening. Mark should be on the side of the drywall facing you.
3. When fastening the drywall in place, do not place nails or screws closer than 12" from the box. This will prevent the drywall from becoming deformed under pressure.
4. Insert cutting bit and install freehand sole plate as outlined on Pages 9 & 10 of this Owner's Manual. Adjust depth of cut so the bit will protrude $\frac{1}{8}$ " beyond the thickness of the drywall.
5. Hold the tool firmly with both hands and turn it ON. Plunge the bit through the drywall at the mark indicating the center of the box. See Fig. 8 for cutting pattern.

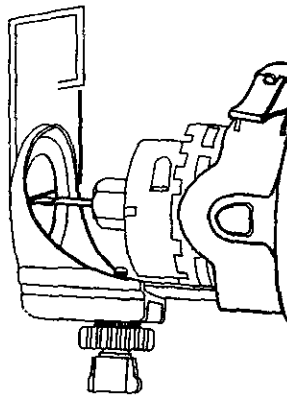

Fig. 8

CUTTING OUTLET OPENINGS IN DRYWALL - cont'd

6. Move the bit **slowly** to the right until you feel and hear the bit contacting the inside of the box.
7. Pull the bit out far enough to slip it over the edge of the box. Once the bit is outside the box, push it back to full depth beside the outside edge of the box.
8. Move the tool upward while applying **slight** pressure toward the center of the box. When you feel the bit reach the top right hand corner of the box, move the tool to the left while applying slight pressure downward toward the center of the box.
9. Continue moving the tool around the box in a counter clockwise direction while maintaining slight pressure toward the center of the box. When the box cut-out is complete. Turn the tool OFF and remove it from the cut-out.
10. Completed electrical box cut-out will be accurately and neatly cut (see Fig. 9).

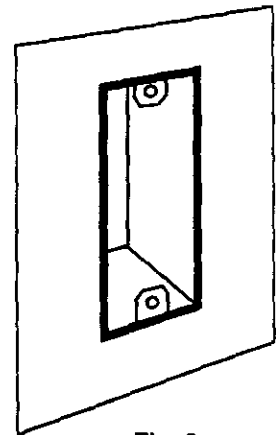

Fig. 9

NOTE: Always move the cutting bit in a **counter clockwise** direction around the outlet box. The natural tendency of the cutting bit to move to the left will make it easier to cut close to the box.

ASSEMBLY & OPERATION

PRECISION HANDLE

INSTALLING PRECISION HANDLE

The precision handle is designed for use when precision control over the tool movement is desired. The comfortable handle can be used with either the right or left hand.

1. Slide precision handle mounting bracket (1) onto the bottom of motor housing (2) until the slot under the handle (3) lines up with the shaft locking button (4) in the motor housing (see Fig. 10).

NOTES:

- a) The mounting bracket must be pushed onto the motor housing as far as it will go.
 - b) The shaft locking button (5) can now be activated by your thumb while holding on to the precision handle
2. Lock the precision handle to the motor housing by snapping the quick locking lever (6) firmly against the motor housing.

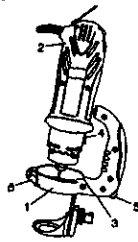

Fig. 10

ADJUSTING FREEHAND SOLE PLATE

1. Adjust precision handle sole plate depth by loosening the depth gauge locking knob (7) and rotating the adjusting knob (8) to move the sole plate (9) in or out as required (see Fig. 11).

NOTE: Set the depth gauge so the cutting bit protrudes beyond the sole plate $\frac{1}{8}$ " more than the thickness of the material being cut. For example, if you are cutting $\frac{3}{4}$ " pine, the bit should protrude $\frac{7}{8}$ " beyond the sole plate.

2. Securely tighten depth gauge knob.
3. Before starting to cut you should re-check bit depth, make sure sole plate is at right angles to the bit and securely tightened. Re-check the collet to make sure the bit is securely fastened.

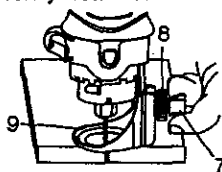

Fig. 11

MAINTENANCE

⚠ DANGER

For your own safety, turn the switch OFF and remove the plug from the power source before maintaining your cutting tool.

When servicing, use only identical Craftsman parts. Use of any other part may create a hazard or cause product damage.

EXTERNAL CLEANING

⚠ WARNING

DO NOT use solvents when cleaning plastic parts. Most plastics are susceptible to damage from various types of commercial solvents and may be damaged by their use. Use clean cloth to remove dirt, dust, oil, grease, etc.

Do not at any time allow brake fluids, gasoline, petroleum-based products, penetrating oils, etc. to come in contact with plastic parts. They contain chemicals that can damage, weaken or destroy plastic

INTERNAL CLEANING

It has been found that electric tools are subjected to accelerated wear and possible premature failure when they are used on fiberglass boats and sports cars, wallboard, spackling compounds or plaster. The chips and grindings from these materials are highly abrasive to electric tool parts such as bearings, brushes, commutators, etc. During any use on these materials it is extremely important that the tool is cleaned frequently by blowing out with a compressed air jet.

⚠ DANGER

It is critical that you wear safety goggles or safety glasses with side shields and a dust mask while blowing dust out of the cutting tool with a compressed air jet. Failure to take these safety precautions could result in permanent eye or lung damage.

POWER CORD MAINTENANCE

⚠ WARNING

To avoid shock or fire hazard, replace the cord immediately if it is worn or damaged in any way.

LUBRICATION

All of the bearings in this cutting tool are lubricated with a sufficient amount of high grade lubricant for the life of the unit under normal conditions. Therefore, no further lubrication is required.

PARTS DIAGRAM – MODEL 183.172530

Main Unit

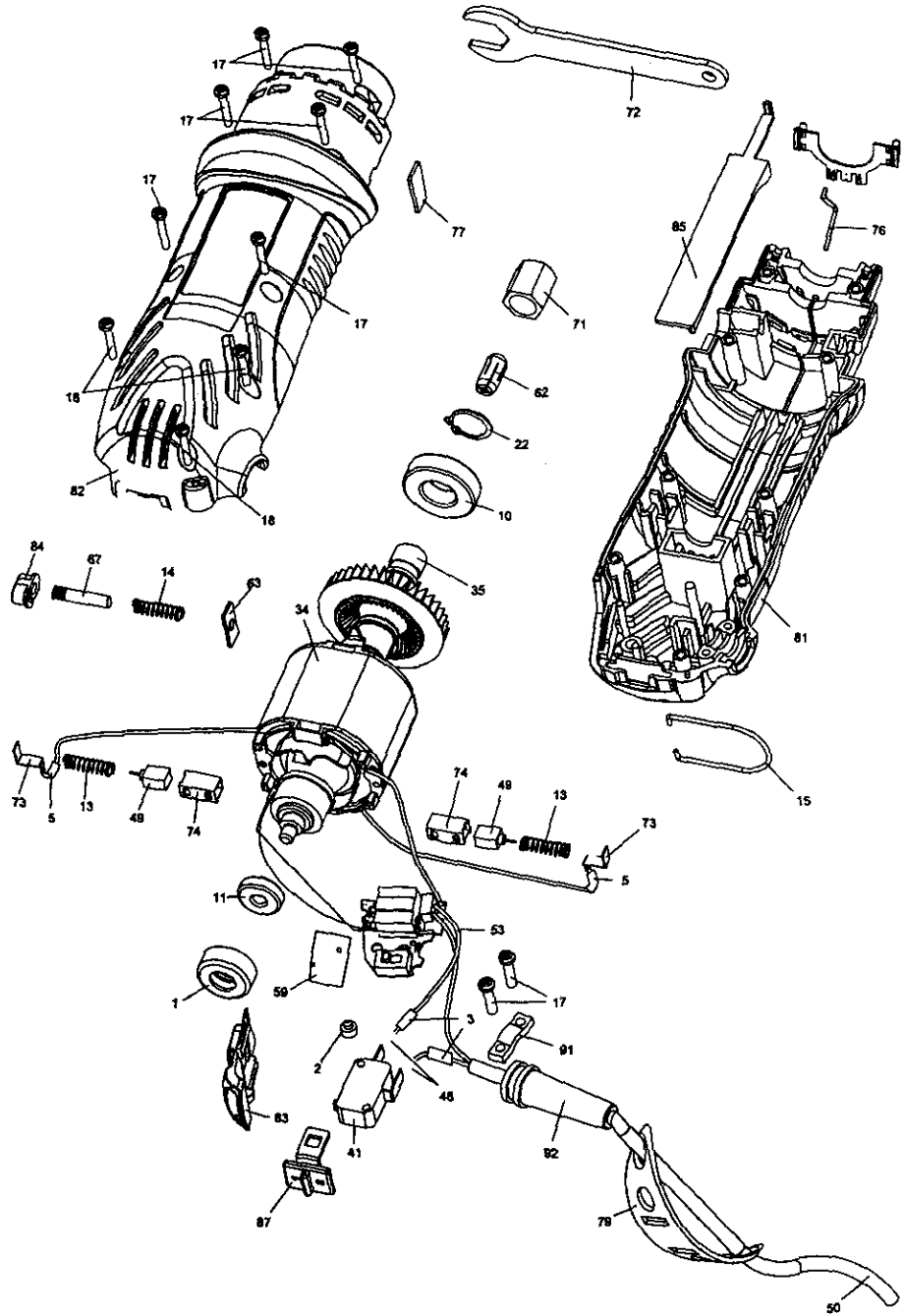

PARTS LIST – MODEL 183.172530

⚠ WARNING

When servicing use only CRAFTSMAN replacement parts. Use of any other parts may create a HAZARD or cause damage to your Cutting Tool.

Any attempt to repair or replace electrical parts on this Cutting Tool may create a hazard unless repair is performed by a qualified technician. Repair service is available by contacting your nearest Sears Service Center.

Always order by PART NUMBER, not by key number.

Main Unit

Key #	Part #	Part Name	Qty	Key #	Part #	Part Name	Qty
1	01AR-000032-00	Bearing Sleeve	1	44	03AT-000033-00	Terminal block	1
2	01AR-000035-00	Switch presser	1	48	03AT-000040-00	Terminal (female)	2
3	01AT-000014-A0	Bushing tube	2	49	03AT-000046-00	Carbon brush	2
5	01AT-000031-00	Bushing tube	2	50	03AW-000131-00	Power cord	1
10	02AE-000060-00	Front bearing	1	53	03AY-000020-00	Wire	1
11	02AE-000061-00	Rear bearing	1	55	03AY-000073-00	Wire	2
12	02AK-000022-00	Rivet	4	56	03AY-000074-00	Wire	2
13	02AH-000088-00	Brush spring	2	59	04AP-000068-00	Fibra	1
14	02AH-000089-00	Spindle spring	1	62	2203-MA0003-00	1/4" collet	1
15	02AH-000112-00	Hanger	1	62	2203-MA0004-00	1/8" collet	1
17	02AS-000199-A0	Case screw	8	63	2203-MA0007-00	Lock plate	1
18	02AS-000201-A0	Screw	3	67	2207-MA0003-00	Spindle lock	1
22	02AW-000055-00	Retaining ring	1	70	2213-MA0002-00	Conductor	2
23	03AA-000279-00	Transformer	1	71	2213-MA0005-00	Chuck cap	1
24	03AC-000011-F0	Capacity	1	72	2213-MA0006-00	Spanner	1
25	03AC-000043-00	Capacity	1	*	2213-SAM001-00	Brush assembly	2
28	03AD-000009-A0	Diode	4	73	2213-MA0011-00	Metal conductor	2
29	03AD-000040-00	Diac	1	74	2213-MA0012-00	Brush case	2
30	03AD-000074-00	LED	2	76	2213-MA0014-00	Wire cover	1
31	03AD-000075-00	Triac	1	77	2213-MA0015-00	Stop plate	1
34	03AM-000104-00	Stator	1	79	2203-PA0008-00	Spanner belt	1
35	03AM-000105-00	Rotor	1	81	2213-PA0022-00	Bottom cabinet	1
36	03AP-000073-00	PCB	1	82	2213-PA0023-00	Top cabinet	1
37	03AP-000076-00	PCB	1	83	2213-PA0024-00	Switch cover	1
38	03AR-000013-A0	Resistor	1	84	2213-PA0025-00	Lock button	1
39	03AR-000015-D0	Resistor	1	85	2213-PA0026-00	Cover	1
40	03AR-000109-A0	Resistor	3	87	2213-PA0028-00	2P-Switch	1
41	03AS-000135-00	Micro switch	1	91	9866-PA0004-00	Press plate	1
42	03AS-000140-00	Switch	1	92	9920-PA0011-00	Cord Sleeve	1

PARTS – MODEL 183.172530

Freehand Soleplate Assembly

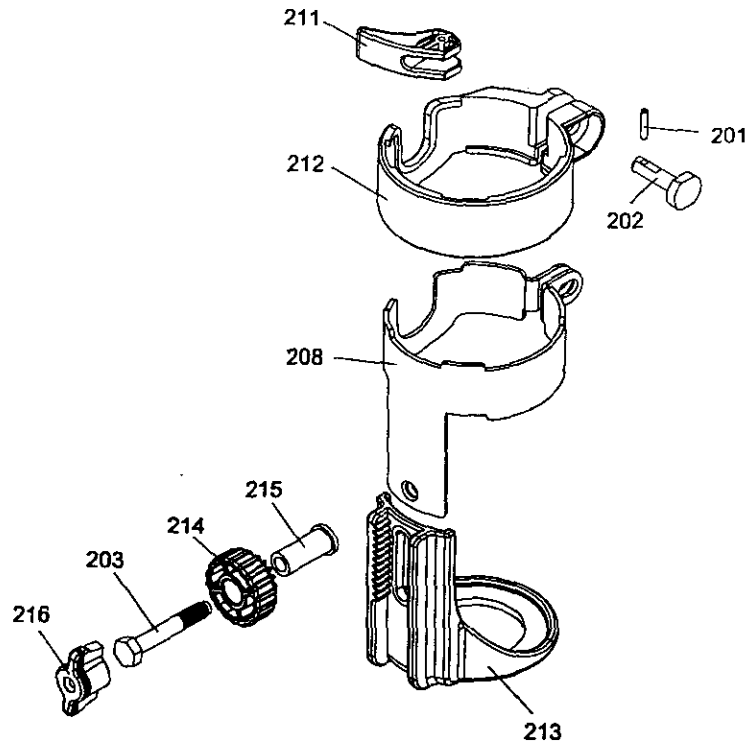

Key #	Part #	Part Name	Qty
201	02AF-000041-10	Fixing shaft	1
202	02AF-000076-00	Release lock pin	1
203	02AS-000287-00	Screw	1
208	2213-MA0010-00	Freecut metal round guide	1
211	2213-PA0010-00	Lock	1
212	2213-PA0011-00	Fixbase	1
213	2213-PA0012-00	Plastic guide base	1
214	2213-PA0013-00	Adjustment Gear 15T	1
215	2213-PA0014-00	Sleeve	1
216	2213-PA0015-00	Screw lock F	1

PARTS – MODEL 183.172530

Handle Assembly

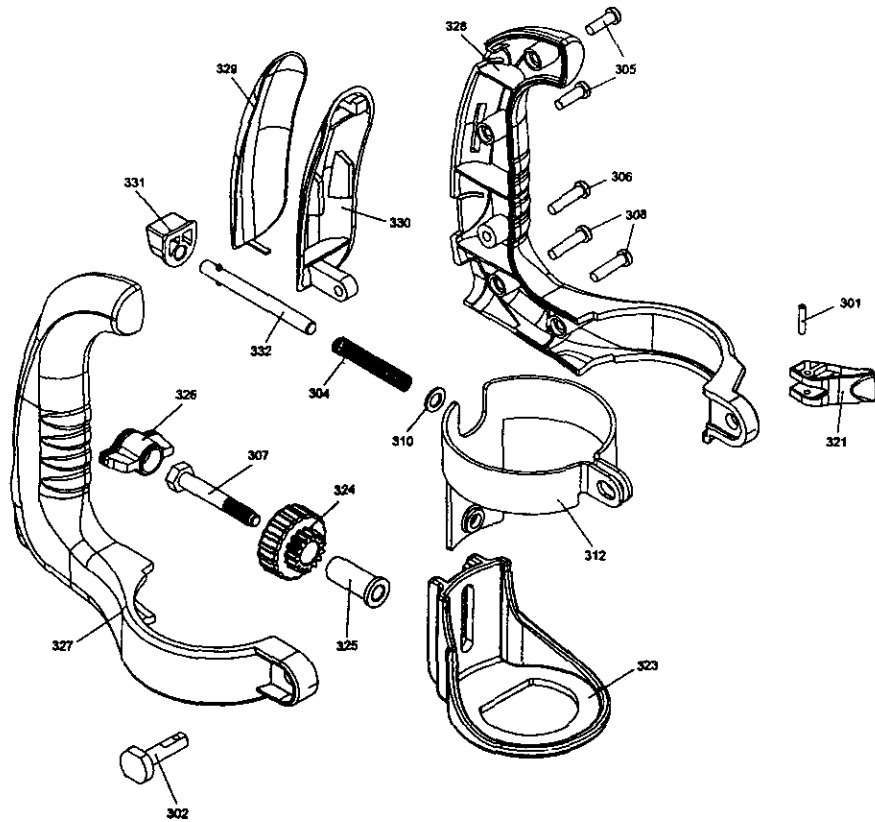

Key #	Part #	Part Name	Qty
301	02AF-000041-10	Fixing shaft	1
302	02AF-000076-00	Release lock pin	1
304	02AH-000106-00	Compressive spring	1
305	02AS-000148-00	Screw	2
306	02AS-000199-A0	Screw	1
307	02AS-000287-00	Screw	1
308	02AS-000288-00	Screw	2
310	02AW-000067-00	Washer	1
312	2213-MA0013-00	S-round guide holder	1
321	2213-PA0010-00	Lock	1
323	2213-PA0012-00	Plastic guide base	1
324	2213-PA0013-00	Adjustment Gear 15T	1
325	2213-PA0014-00	Sleeve	1
326	2213-PA0015-00	Screw lock F	1
327	2213-PA0016-00	Anx right handle	1
328	2213-PA0017-00	Anx left handle	1
329	2213-PA0018-00	Anx handle softgrip (outside)	1
330	2213-PA0019-00	Anx handle softgrip (inside)	1
331	2213-PA0020-00	Simple lock	1
332	2213-PA0021-00	Shaft F5-5	1

Get it fixed, at your home or ours!

For repair of major brand appliances in your own home...
no matter who made it, no matter who sold it!

1-800-4-MY-HOME® Anytime, day or night
(1-800-469-4663) (U.S.A. and Canada)
www.sears.com www.sears.ca

For repair of carry-in products like vacuums, lawn equipment,
and electronics, call for the location of your nearest
Sears Parts and Repair Center.

1-800-488-1222 Anytime, day or night (U.S.A. only)
www.sears.com

For the replacement parts, accessories and owner's manuals
that you need to do-it-yourself, call **Sears PartsDirect™**!

1-800-366-PART 6 a.m. – 11 p.m. CST, 7 days a week
(1-800-366-7278) (U.S.A. only)
www.sears.com/partsdirect

To purchase or inquire about a Sears Service Agreement
or Sears Maintenance Agreement:

1-800-827-6655 (U.S.A.)	1-800-361-6665 (Canada)
7 a.m. – 5 p.m. CST, Mon. – Sat.	9 a.m. – 8 p.m. EST, M – F, 4 p.m. Sat.

Para pedir servicio de reparación a
domicilio, y para ordenar piezas:

1-888-SU-HOGAR™
(1-888-784-6427)

Au Canada pour service en français:

1-800-LE-FOYER™
(1-800-533-6937)
www.sears.ca



© Registered Trademark / ™ Trademark / ℠ Service Mark of Sears, Roebuck and Co.
© Marca Registrada / ™ Marca de Fábrica / ℠ Marca de Servicio de Sears, Roebuck and Co.
™ Marqué de commerce / ℠ Marqué déposé de Sears, Roebuck and Co.

© Sears, Roebuck and Co.