

Operator's Manual



1/3 HP (Max. Developed)

2480 F.P.M. (No load)

9" BAND SAW

Model No.

137.214090

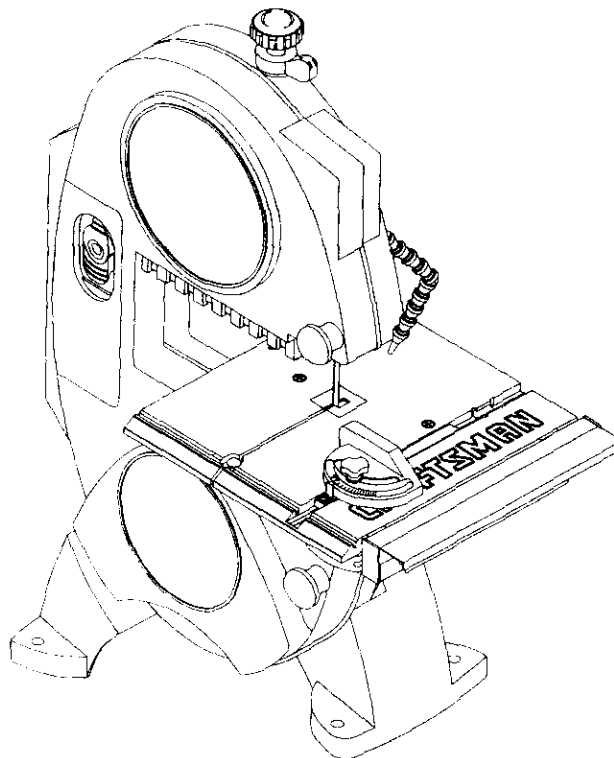

CAUTION:

Before using this Band Saw, read this manual and follow all its Safety Rules and Operating Instructions

- Safety Instructions
- Installation
- Operation
- Maintenance
- Parts List
- Español

Customer Help Line
1-800-843-1682

Sears, Roebuck and Co., Hoffman Estates, IL 60179 U.S.A.
Visit our Craftsman website: www.sears.com/craftsman

Part No. 13721409001

TABLE OF CONTENTS

SECTION	PAGE
Warranty	2
Products Specifications	2
Safety Instructions	3
Accessories and Attachments	6
Carton Contents	6
Know Your Band Saw	7
Glossary of Terms	8
Assembly and Adjustments	9
Operation	15
Maintenance	17
Troubleshooting Guide	18
Parts	20
Español.....	22

WARRANTY

FULL ONE YEAR WARRANTY

If this Band Saw fails due to a defect in material or workmanship within one year of date of purchase, Sears will at its option repair or replace it free of charge.

Return this Band Saw to a Sears Service Center for repair, or to place of purchase for replacement.

This warranty gives you specific legal rights, and you may also have other rights that may vary from state to state.

Sears, Roebuck and Co., Dept. 817 WA, Hoffman Estates, IL 60179

▲ WARNING

Some dust created by power sanding, sawing, grinding, drilling and other construction activities contains chemicals known to the state of California, to cause cancer, birth defects or other reproductive harm. Some examples of these chemicals are:

- Lead from lead-based paints
- Crystalline silica from bricks, cement and other masonry products
- Arsenic and chromium from chemically treated lumber

Your risk from these exposures varies, depending on how often you do this type of work. To reduce your exposure to these chemicals, work in a well-ventilated area and work with approved safety equipment such as dust masks that are specially designed to filter out microscopic particles.

PRODUCT SPECIFICATIONS

Motor

Power source 120 V, 60 Hz, 2.5Amp., Ac
 Speed 2480FPM (No load)
 Speed control Electronic
 Horsepower..... 1/3HP(Max. Developed)

Sawdust blower Yes
 Net weight 30.8 lbs.

Cutting Capacity

Throat 9"
 Height 3-1/2"

▲ WARNING

To avoid electrical hazards, fire hazards, or damage to the tool, use proper circuit protection. Use a separate electrical circuit for your tools.

Blade

Width 1/8" to 3/8"
 Length 59" to 59-1/4"

This Band Saw is wired at the factory for 120V operation. Connect to a 120V, 15 AMP branch circuit and use a 15 Amp time delay fuse or circuit breaker. To avoid shock or fire, replace power cord immediately if it is worn, cut or damaged in any way.

Table

Size 12-1/4" x 11-1/2"
 Tilt 0° - 3° Left; 0° - 45° Right

Table Extension Yes, with fence

Extension fence Capacity. 12" Right

SAFETY

GENERAL SAFETY INSTRUCTIONS

BEFORE USING THE BAND SAW

Safety is a combination of common sense, staying alert and knowing how to use this Band Saw.

▲ WARNING

To avoid mistakes that could cause serious injury, do not plug the Band Saw in until you have read and understood the following:

1. **READ** and become familiar with the entire Operator's Manual. **LEARN** the tool's application, limitations and possible hazards.
2. **KEEP GUARDS IN PLACE** and in working order.
3. **REMOVE ADJUSTING KEYS AND WRENCHES.** Form the habit of checking to see that keys and adjusting wrenches are removed from the tool before turning ON.
4. **KEEP WORK AREA CLEAN.** Cluttered areas and benches invite accidents.
5. **DON'T USE IN DANGEROUS ENVIRONMENT.** Don't use power tools in damp or wet locations, or expose them to rain. Keep work area well lighted.
6. **KEEP CHILDREN AWAY.** All visitors should be kept a safe distance from work area.
7. **MAKE WORKSHOP CHILD PROOF** with padlocks, master switches, or by removing starter keys.
8. **DON'T FORCE THE TOOL.** It will do the job better and safer at the rate for which it was designed.
9. **USE THE RIGHT TOOL.** Do not force tool or attachment to do a job for which it was not designed.
10. **USE PROPER EXTENSION CORD.** Make sure your extension cord is in good condition. When using an extension cord, be sure to use one heavy enough to carry the current your product will draw. An undersized cord will result in a drop in line voltage and in loss of power that will cause the tool to overheat. The table on page 5 shows the correct size to use depending on cord length and nameplate ampere rating. If in doubt, use the next heavier gauge. The smaller the gauge number, the heavier the cord.
11. **WEAR PROPER APPAREL.** Do not wear loose clothing, gloves, neckties, rings, bracelets, or other jewelry that may get caught in moving parts. Non-slip footwear is recommended. Wear protective hair covering to contain long hair.
12. **ALWAYS WEAR EYE PROTECTION.** Any Band Saw can throw foreign objects into the eyes that could cause permanent eye damage. **ALWAYS** wear Safety Goggles (not glasses) that comply with ANSI Safety standard Z87.1. Everyday eyeglasses have only impact-resistance lenses. They **ARE NOT** safety glasses. Safety Goggles are available at Sears. **NOTE:** Glasses or goggles not in compliance with ANSI Z87.1 could cause serious injury.
13. **WEAR A FACE MASK OR DUST MASK.** Sawing operation produces dust.
14. **SECURE WORK.** Use clamps or a vise to hold work when practical. It's safer than using your hand and it frees both hands to operate tool.
15. **DISCONNECT TOOLS** before servicing; when changing accessories such as blades, bits, cutters, and the like.
16. **REDUCE THE RISK OF UNINTENTIONAL STARTING.** Make sure switch is in OFF position before plugging in.
17. **USE RECOMMENDED ACCESSORIES.** Consult the Operator's Manual for recommended accessories. The use of improper accessories may cause serious injury.
18. **NEVER STAND ON TOOL.** Serious injury could occur if the tool is tipped or if the cutting tool is unintentionally contacted.
19. **CHECK FOR DAMAGED PARTS.** Before further use of the tool, a guard or other part that is damaged should be carefully checked to determine that it will operate properly and perform its intended function – check for alignment of moving parts, binding of moving parts, breakage of parts, mounting, and any other conditions that may affect its operation. A guard or other part that is damaged should be properly repaired or replaced.
20. **NEVER LEAVE TOOL RUNNING UNATTENDED. TURN POWER "OFF".** Don't leave tool until it comes to a complete stop.
21. **DON'T OVERREACH.** Keep proper footing and balance at all times.
22. **MAINTAIN TOOLS WITH CARE.** Keep tools sharp and clean for best and safest performance. Follow instructions for lubricating and changing accessories.
23. **DO NOT** use power tools in the presence of flammable liquids or gases.

24. **DO NOT OPERATE** the tool if you are under the influence of any drugs, alcohol or medication that could affect your ability to use the tool properly.

25. **ALWAYS** operate the band saw in a well-ventilated area and provide for proper dust removal. Use dust collection systems whenever possible. Dust generated from certain materials can be hazardous to your health.

SPECIFIC SAFETY INSTRUCTIONS FOR BAND SAWS

1. **TO AVOID INJURY** from unexpected movement, make sure the saw is on a firm, level surface, properly secured to prevent rocking. Make sure there is adequate space for operating. Bolt the saw to a support surface to prevent slipping, walking, or sliding during operation.
2. **TURN** the saw OFF and unplug the saw before moving it.
3. **USE THE CORRECT** size and style of blade.
4. **USE** blades rated at 2480 FPM or greater.
5. **MAKE SURE** the blade teeth point down and towards the table.
6. **BLADE GUIDES, SUPPORT BEARINGS, AND BLADE TENSION** must be properly adjusted to avoid accidental blade contact and to minimize blade breakage. To maximize blade support, always adjust the upper blade guide and blade guard so that it is 1/8 inch above the workpiece.
7. **TABLE LOCK HANDLE** should be tight.
8. **USE EXTRA CAUTION** with large, very small or awkward workpieces.
9. **USE EXTRA SUPPORTS** to prevent workpieces from sliding off the table top. Never use another person to support the workpiece.
10. **WORKPIECES** must be secured so they don't twist, rock, or slip while being cut.
11. **PLAN** intricate and small work carefully to avoid pinching the blade. Avoid awkward operation and hand positions to prevent accidental contact with the blade.

12. **SMALL PIECES** should be secured with jigs or fixtures. Do not hand hold pieces that are so small your fingers are under the blade guard.

13. **SUPPORT** round work properly (with a V-block or clamped to the miter gauge) to prevent it from rolling and the blade from biting.

14. **CUT** only one workpiece at a time. Make sure the table is clear of everything except the workpiece and its guides before you turn the saw on.

15. **ALWAYS WATCH** the saw run before each use. If there is excessive vibration or unusual noise, stop immediately. Turn the saw OFF. Unplug it immediately. Do not start the saw again until the problem has been located and corrected.

16. **TO FREE** any jammed material, turn the switch OFF. Remove the switch key and unplug the saw. Wait for all moving parts to stop before removing jammed material.

17. **DON'T LEAVE** the work area until all moving parts are stopped. To child-proof the workshop, shut OFF the power to master switches and remove the switch key from the band saw. Store it in a safe place, away from children.

A WARNING

For your own safety, read the entire instruction manual before operating the band saw.

1. Wear eye protection.
2. Do not wear gloves, necktie, or loose clothing.
3. Make sure the saw is on a firm level surface and properly secured.
4. **USE ONLY THE RECOMMENDED ACCESSORIES.**
5. Use extra caution with very large, very small, or awkward workpieces.
6. Keep hands away from the blade at all times to prevent accidental injury.
7. Do not remove jammed cutoff pieces until the blade has stopped.
8. Maintain proper adjustment of blade tension, blade guides and thrust bearings.
9. Adjust upper guide to just clear the workpiece.
10. Hold the workpiece firmly against the table.

ELECTRICAL REQUIREMENTS

GROUNDING INSTRUCTIONS

IN THE EVENT OF A MALFUNCTION OR BREAKDOWN, grounding provides a path of least resistance for electric current and reduces the risk of electric shock. This tool is equipped with an electric cord that has an equipment-grounding conductor and a grounding plug. The plug **MUST** be plugged into a matching receptacle that is properly installed and grounded in accordance with ALL local codes and ordinances.

DO NOT MODIFY THE PLUG PROVIDED. If it will not fit the receptacle, have the proper receptacle installed by a qualified electrician.

IMPROPER CONNECTION of the equipment-grounding conductor can result in risk of electric shock. The conductor with green insulation (with or without yellow stripes) is the equipment-grounding conductor. If repair or replacement of the electric cord or plug is necessary, **DO NOT** connect the equipment-grounding conductor to a live terminal.

CHECK with a qualified electrician or service person if you do not completely understand the grounding instructions, or if you are not sure the tool is properly grounded.

USE ONLY 3-WIRE EXTENSION CORDS THAT HAVE 3-PRONG GROUNDING PLUGS AND 3-POLE RECEPTACLES THAT ACCEPT THE TOOL'S PLUG. REPAIR OR REPLACE DAMAGED OR WORN CORD IMMEDIATELY.

GUIDELINES FOR EXTENSION CORDS

USE PROPER EXTENSION CORD. Make sure your extension cord is in good condition. When using an extension cord, be sure to use one heavy enough to carry the current your product will draw. An undersized cord will cause a drop in line voltage, resulting in loss of power and cause overheating. The table below shows the correct size to use depending on cord length and nameplate ampere rating. If in doubt, use the next heavier gauge. The smaller the gauge number, the heavier the cord.

Be sure your extension cord is properly wired and in good condition. Always replace a damaged extension cord or have it repaired by a qualified person before using it. Protect your extension cords from sharp objects, excessive heat and damp or wet areas.

Use a separate electrical circuit for your tools. This circuit must not be less than # 12 wire and should be protected with a 15 Amp time delay fuse. Before connecting the motor to the power line, make sure the switch is in the OFF position and the electric current is rated the same

as the current stamped on the motor nameplate. Running at a lower voltage will damage the motor. This tool is intended for use on a circuit that has a receptacle like the one illustrated in Figure A. Figure A shows a 3-prong electrical plug and receptacle that has a grounding conductor. If a properly grounded receptacle is not available, an adapter (Figure B) can be used to temporarily connect this plug to a 2-contact grounded receptacle. The temporary adapter should be used only until a properly grounded receptacle can be installed by a qualified technician. The adapter (Figure B) has a rigid lug extending from it that **MUST** be connected to a permanent earth ground, such as a properly grounded receptacle box. The Canadian Electrical Code prohibits the use of the adapters.

CAUTION: In all cases, make certain the receptacle is properly grounded. If you are not sure, have a qualified electrician check the receptacle.

▲ WARNING

This tool is for indoor use only. Do not expose to rain or use in damp locations.

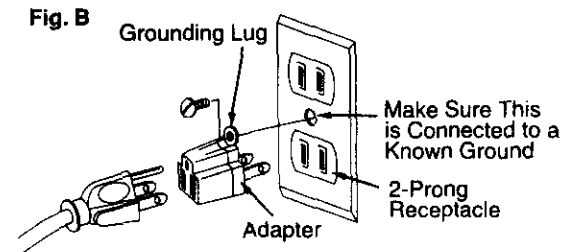
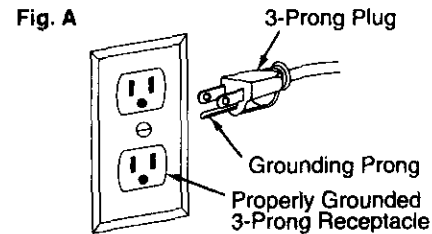

▲ WARNING

This tool must be grounded while in use to protect the operator from electrical shock.

MINIMUM GAUGE FOR EXTENSION CORDS (AWG)					
(When using 120 volts only)					
Ampere	Rating	Total length of cord in feet			
More than	not more than	25'	50'	100'	150'
0	6	18	16	16	14
6	10	18	16	14	12
10	12	16	16	14	12
12	16	14	12	not recommended	

ACCESSORIES AND ATTACHMENTS

RECOMMENDED ACCESSORIES

▲ WARNING

To avoid injury:

- Use only accessories recommended for this band saw.
- Follow instructions that accompany accessories. Use of improper accessories may cause hazards.
- Use only accessories designed for this band saw to avoid injury from thrown broken parts or workpieces.
- Do not use any accessory unless you have completely read the instruction or operator's manual for that accessory.

Visit your Sears Hardware Department or see the Sears Power and Hand Tool Catalog for the following accessories:

ITEM

Miter gauge

Blade width: 1/8" to 3/8"

Blade length: 59" to 59-1/4"

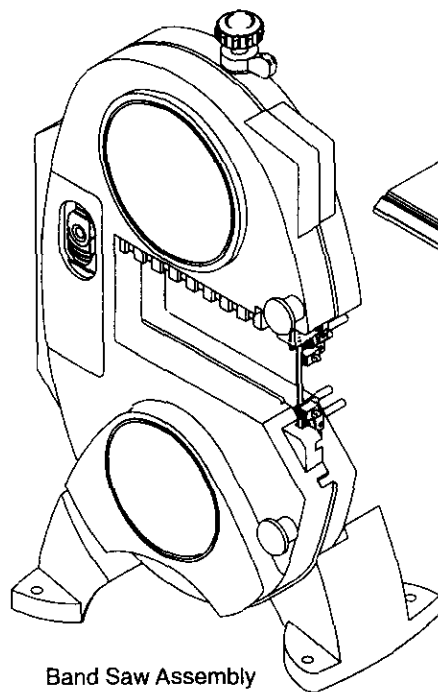

Band Saw Assembly

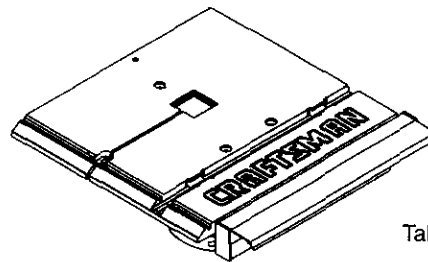
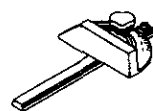
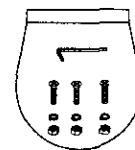

Table Assembly



Miter Gauge



Hex. Nut

Hex. Wrench

Bolt

Spring Washer

CARTON CONTENTS

UNPACKING AND CHECKING CONTENTS

Carefully unpack the band saw and all its parts, and compare against the illustration following. Place the saw on a secure surface and examine it carefully.

▲ WARNING

- To avoid injury from unexpected starting, do not plug the power cord into a power source receptacle during unpacking and assembly. This cord must remain unplugged whenever you are assembling or adjusting the saw.
- Although compact, this saw is heavy. To avoid back injury, get help whenever you have to lift the saw.
- If any part is missing or damaged, do not plug the band saw in until the missing or damaged part is replaced, and assembly is complete.

KNOW YOUR BAND SAW

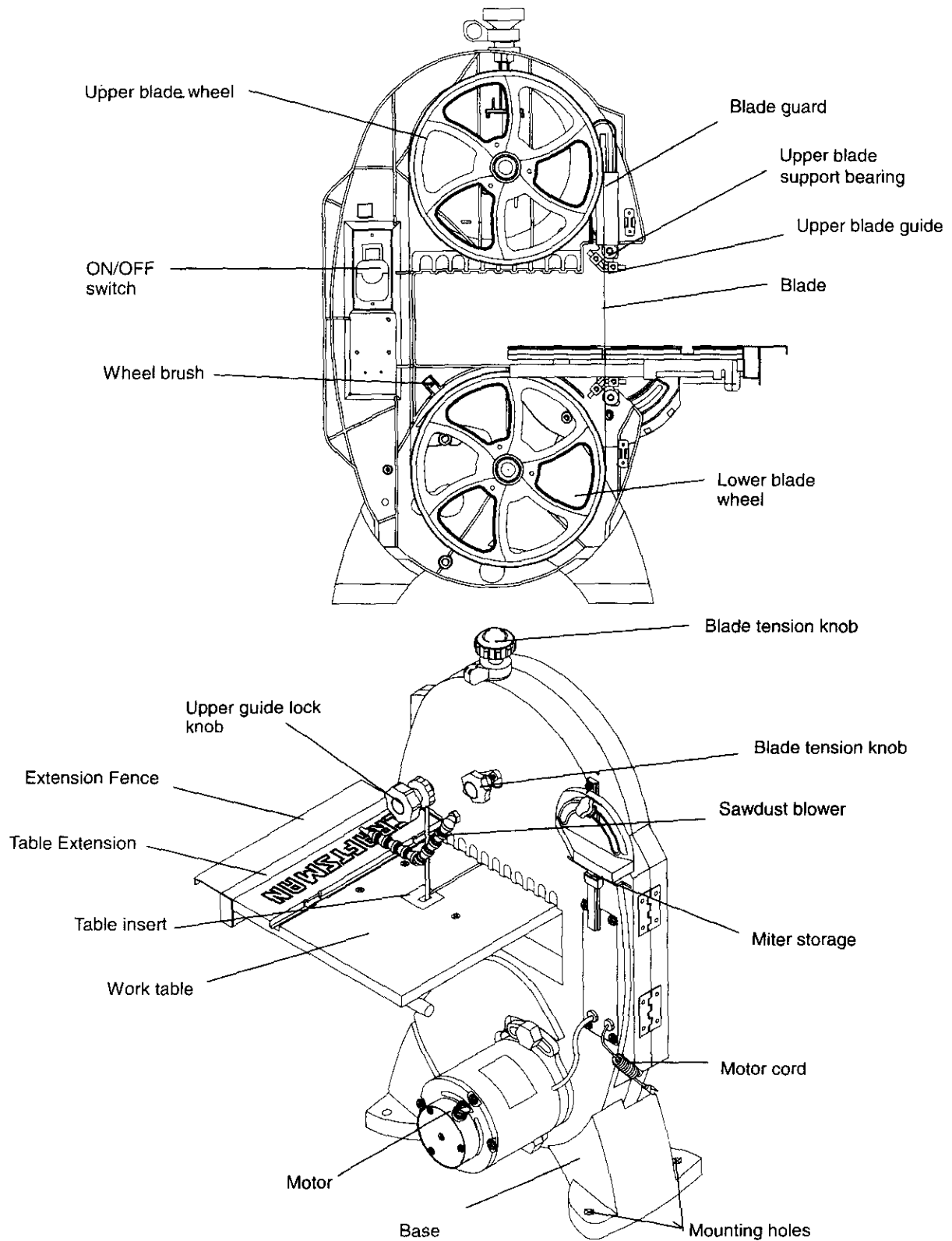

GLOSSARY OF TERMS

BAND SAW TERMS

BLADE GUIDES — Support the blade and keep it from twisting during operation. Blade guides must be adjusted when blade is changed or replaced.

UPPER GUIDE LOCK KNOB — locks the upper slide. Use it after adjusting the upper guide assembly to make sure upper blade guide just clears workpiece before cutting. Upper guide lock knob must be tightened before the band saw is turned on.

TABLE LOCK KNOB — locks the table in place.

TILT (BEVEL) SCALE — shows the degree the table is tilted for bevel cutting.

BLADE TENSION KNOB — controls the amount of blade tension when changing blades.

BLADE TRACKING KNOB — adjusts blade position so blade always runs in the center of the wheel.

SAWDUST PORT — helps keep the machine free from sawdust. The sawdust port makes an excellent hook-up for a wet/dry vacuum.

ON/OFF SWITCH — has a built-in child safety lock. To lock the switch in the OFF position, remove the switch key from the switch.

WOODWORKING TERMS

BEVEL CUT — An angle cut made through the face of a workpiece.

COMPOUND CUT — A simultaneous bevel and miter cut.

CROSSCUT — A cut made across the width of the workpiece.

F.P.M. — Feet per minute. Used in reference to the surface speed of the saw blade.

FREE HAND — Performing a cut without using a fence (guide), hold-down or other proper device to prevent the workpiece from twisting during the cutting operation.

GUM — A sticky sap-based residue from wood products.

HEEL — Misalignment of the blade.

KERF — The material removed by the blade in a through cut, or the slot produced by the blade in a non-through or partial cut.

LEADING EDGE — The front edge of the workpiece pushed into the cutting tool first.

MITER CUT — An angle cut made across the width of a workpiece.

RESAW — A cutting operation to reduce the thickness of the workpiece to make thinner workpiece.

RESIN — A sticky sap that has hardened.

RIPPING CUT — A cutting operation along the length of the workpiece.

R.P.M. — Revolutions per minute. The number of turns completed by a spinning object in one minute.

SAW BLADE PATH — The area of the workpiece or table top directly in line with the travel of the blade or the part of the workpiece that will be cut.

SET — The distance between two saw blade teeth tips, that are bent outward in opposite directions to each other. The further apart the tips are, the greater the set.

TRAILING EDGE — The workpiece edge last cut by the blade.

WORKPIECE — The item being cut. The surfaces of a workpiece are commonly referred to as faces, ends and edges.

WORKTABLE — The surface on which the workpiece rests while performing a cutting or sanding operation.

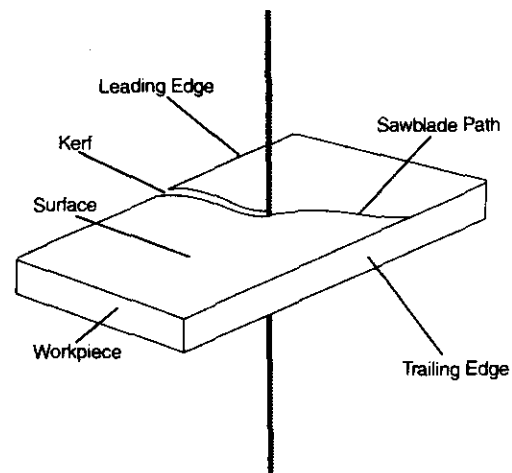

ASSEMBLY AND ADJUSTMENTS

ASSEMBLY INSTRUCTIONS

TOOLS NEEDED

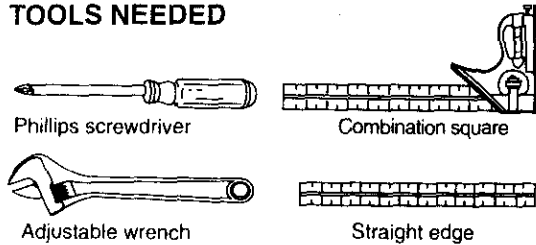

▲ WARNING

For your safety, never connect plug to power source receptacle until all assembly and adjustment steps are completed, and you have read and understood the safety and operating instructions.

Fig. B

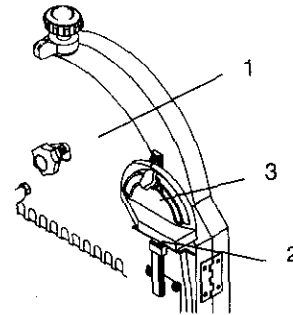

SAWDUST COLLECTION PORT (FIG. C)

This band saw will accept a hose or vacuum accessory (not provided) to be connected to the port (1) on the right side of base. If excessive sawdust buildup occurs inside the base, use a wet /dry vacuum cleaner or manually remove sawdust by removing the screws on the right side of saw. Reattach the metal plate and screws before starting the saw. This will keep your saw cutting efficiently.

Fig. C

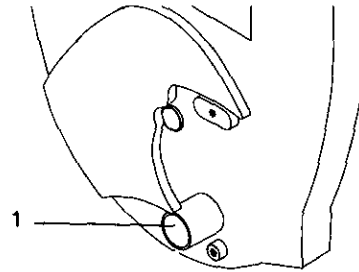

ASSEMBLY THE TABLE (FIG. D)

1. Remove the table aligning screw (1) from the table (2).
2. Guide the table slot (3) over the saw blade and rotate a 1/4 turn, so the slot is perpendicular to the flat side of the blade.
3. Insert three bolts (4) through the table holes, place spring washers (5) and hex nuts (6) on the bolts. Do not tighten.
4. Align the 0° mark on the scale to the pointer on the support bracket.
5. Place the table aligning screw (1) in the front of the table, in the slot (3), and tighten.

Fig. D

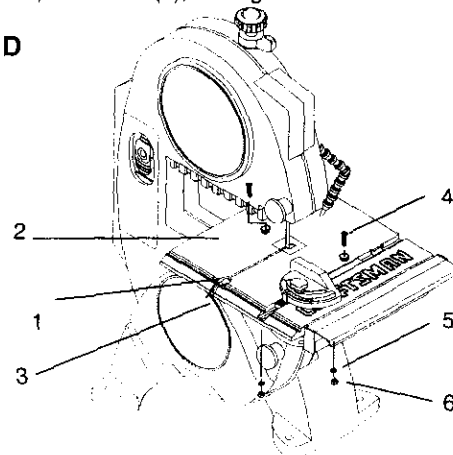

MITER GAUGE STORAGE (FIG. B)

The right rear side of the body (1) has a slot (2) designed to store the miter gauge (3).

INSTALLING AND REMOVING BLADES (FIG. E)

⚠ WARNING

To avoid injury from accidental starting, always turn the switch OFF and remove power cord plug from power source before removing or replacing the blade.

Removing

1. Loosen the blade tension by turning the blade tension knob (1) counterclockwise.
2. Remove the table aligning screw (2) from the table.
3. Open the wheel cover.
4. Loosen the two blade guard mounting screws and remove the blade guide (5).
5. Carefully pull the blade from the side slot (6) and from the wheels (7).
6. Swing the left side of the blade toward you, turning the blade so it will fit through the slot (8) in the table, and remove.

Installing

1. Make sure the blade tension knob (1) is turned counterclockwise until it stops.
2. Remove the table aligning screw (2) from the table.
3. Open the wheel cover.
4. Guide the new blade (4) through the table slot (8), making sure the blade teeth are pointing forward and down.

NOTE: To avoid lifting the workpiece, the blade teeth must point downward toward the table.

5. Swinging the left side away and back, place the blade on the upper and lower wheels (7).
6. Place the blade carefully between the upper and lower blade guides (5).
7. Slide the blade into the slot (6) at the left of the wheels, and make sure the blade is positioned at the middle of the wheels.
8. Install the blade guard by threading the two blade guard mounting screws tightly.
9. Turning the blade tension knob clockwise, tighten the tension until the blade is tight on the wheels.
10. Replace the aligning screw (2).
11. Adjust the blade tracking and tension properly (See ADJUSTMENT) before operating the band saw.

Fig. E

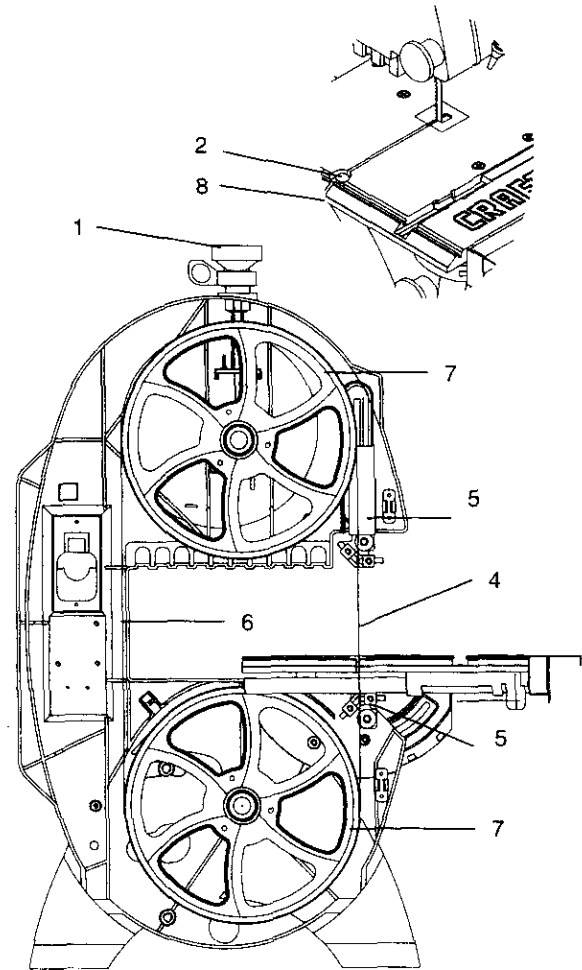

MITER GAUGE (FIG. F)

A miter gauge (1) is supplied with your band saw to be used with the table (2). The table is equipped with a slot on the right side of the blade for the miter gauge. The miter gauge can be tilted 0° to 45° right or left.

Fig. F

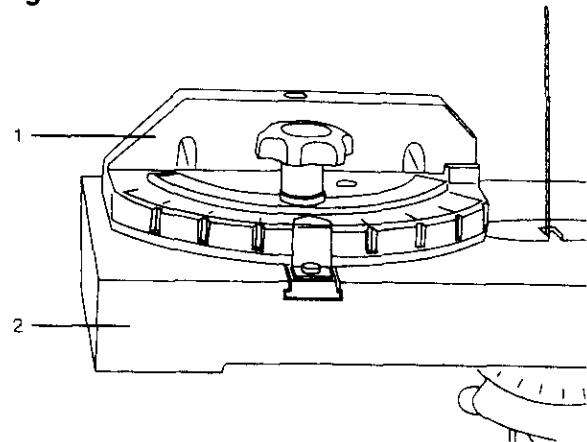

ADJUSTMENT

▲ WARNING

To avoid injury, turn the switch OFF and unplug the band saw from the power source before making any adjustments.

TILTING THE TABLE (FIG. G)

The band saw table (1) tilts 0° to 45° to the right.

1. Loosen the handle lock knob (2) underneath the table.
2. Tilt the table to the desired angle as shown on the scale (3).
3. Tighten the lock knob.

NOTE: The 90° table stop bolt must be removed to tilt the table 10° or more the left.

Fig. G

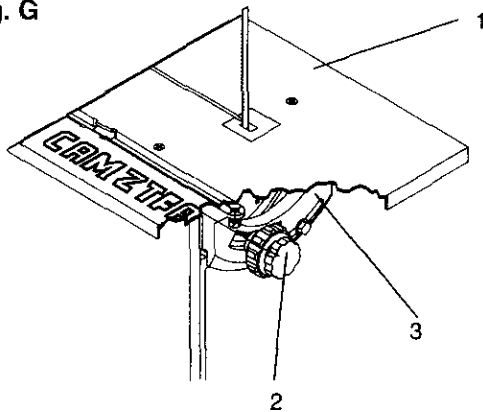

ADJUSTING THE 90° TABLE STOP (FIG. H)

1. Loosen table tilting lock knob (1).
2. Place a combination square (2) or level on the table with one end of the square against the blade.
3. Tilt table until the top table surface is at a 90° angle to the blade and tighten the table tilting lock knob.
4. Using the wrench (3) supplied, turn the set screw (4) until the screw touches the frame.
5. Set the table tilting pointer to line up with the zero mark on the table turning.

NOTE: The table stop bolt must be removed to tilt the table up to 3° left.

Fig. H

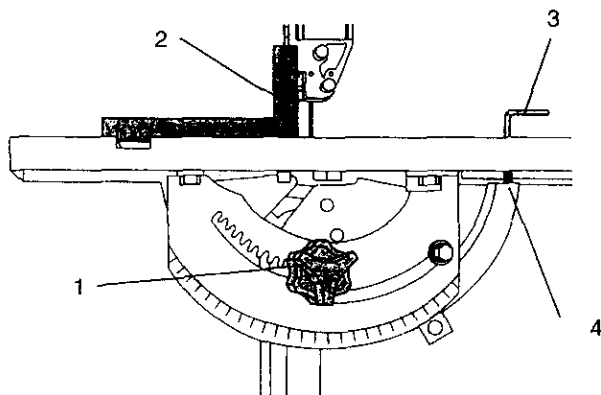

BLADE TENSION (FIG. I)

▲ WARNING

To avoid injury, turn the switch OFF and disconnect the saw from the power source before making any adjustments. NEVER make tension adjustments with the machine running.

1. Turn blade tension adjusting knob (1) clockwise until blade (2) is tensioned.
2. Blade tension can be checked by pushing on the blade. The blade should move slightly with firm finger pressure.

NOTE: Over tensioning the blade may cause breakage. Too little tension may cause the blade to slip on the wheels.

Fig. I

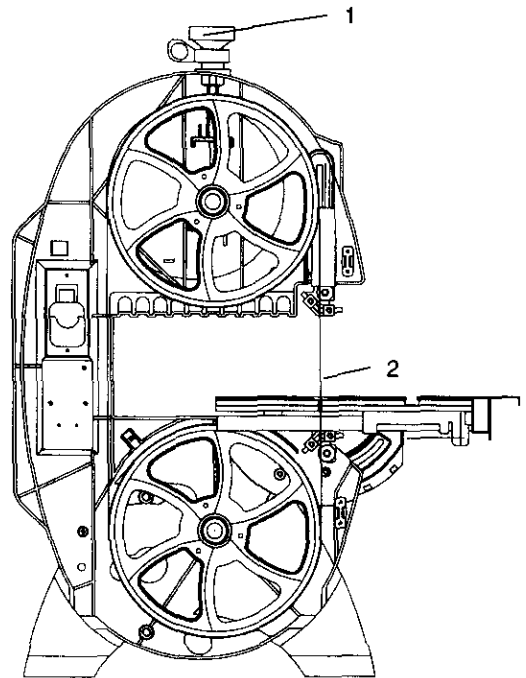

BLADE TRACKING (FIG. J)

▲ WARNING

To avoid injury, turn the switch OFF and disconnect the saw from the power source before making any adjustments. Never make tracking adjustments with the machine running.

1. The blade (1) must be tensioned properly before adjusting the tracking. (See BLADE TENSION on page 11).
2. Open the wheel cover.
3. Move the blade guides (2) and support bearings (3) away from the blade, if necessary. (See page 13).
4. Rotate the wheel (4) slowly forward by hand, and check the position of the blade on the wheel. The blade should remain centered on the wheel as it turns.
5. If the blade moves toward the front of the wheel, turn the tracking knob (5) on the rear of the band saw clockwise. This tilts the top of the wheel and moves the blade toward the center.
6. If the blade moves toward the back edge, turn the tracking knob counterclockwise, moving the blade toward the center.

NOTE: Turn the tracking knob SLIGHTLY to make blade tracking adjustments.

Fig. J

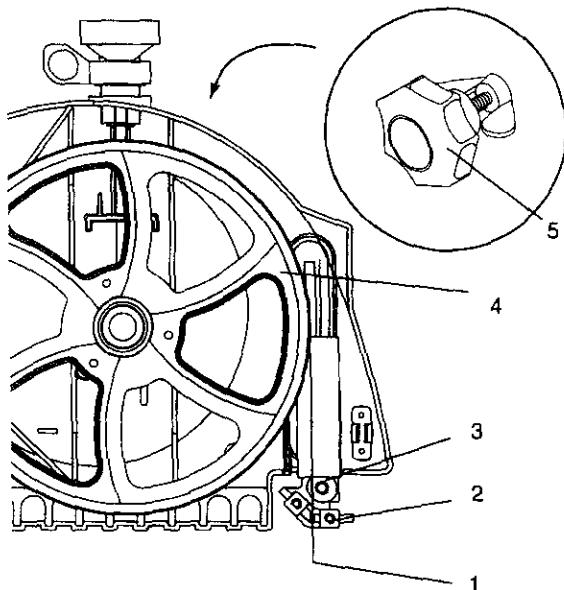

UPPER BLADE GUIDE ASSEMBLY (FIG. K)

▲ WARNING

To avoid injury, turn the switch OFF and disconnect the saw from the power source before making any adjustment. NEVER make adjustments with the machine running.

1. Loosen the lock knob (1) and move the blade guide assembly (2) to 1/8" above the workpiece.
2. Rotate the assembly, if necessary, until the guide blocks (2) are flat (parallel) to the blade (4). Tighten the lock knob.

Fig. K

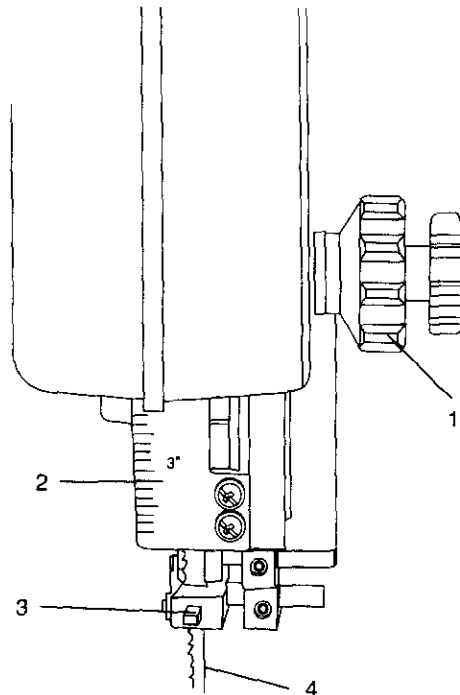

UPPER BLADE GUIDES AND BLADE SUPPORT BEARING (FIG. L, M)

▲ WARNING

The blade guard has been removed for clarity of illustration. To avoid injury never operate the band saw without all guards in place and in working order.

▲ WARNING

To avoid injury, turn the switch OFF and disconnect the saw from the power source before making any adjustments. NEVER make adjustments with the machine running.

NOTE: Make sure the blade is tensioned and tracking properly. Adjust the blade guides and support bearing after each blade tension and tracking adjustment. When the upper blade guides and support bearings are adjusted, the lower guides and bearings should also be adjusted.

Blade guides (Fig. L)

1. Make sure the blade is tensioned and tracking properly.
2. Loosen the front hex socket screws (1) with a hex wrench.
3. Move the guide blocks (2) as close to the blade (2) as possible without pinching it.
4. Using a feeler gauge, make sure the space between guide block and blade measures 0.02" (the thickness of a dollar bill).
5. Tighten the hex socket screws.
6. Loosen the side screw (4) by turning counter clockwise.
7. Tighten the screw.

Fig. L

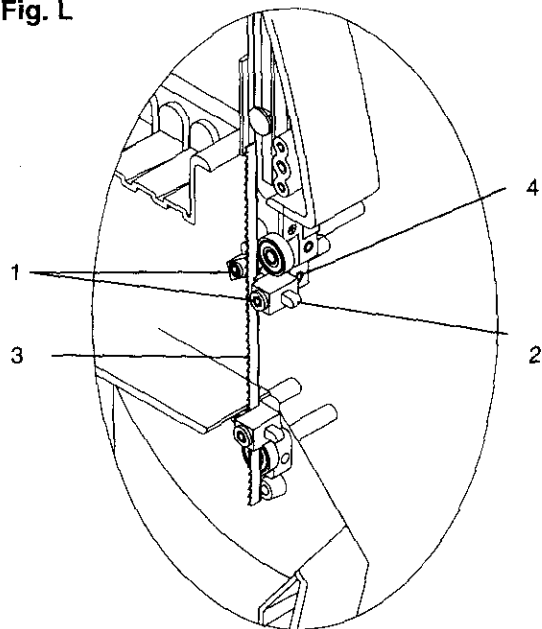

Support bearing (Fig. M)

8. Loosen the screw (6).
9. Move the support bearing (8) in or out, until the bearing is 1/64" behind the blade.
10. Tighten the screw (6).

NOTE: The blade support bearing prevents the blade from moving back too far and damaging the saw teeth setting.

11. Check the lateral position of the support bearing (8). The vertical back edge of the blade (3) should overlap the front face of the support bearing 1/16" to 1/8" to the left of the right bearing, as shown.

Fig. M

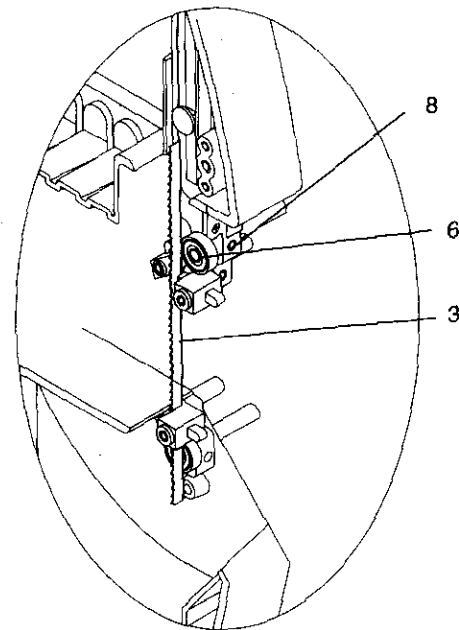

**LOWER BLADE GUIDES AND SUPPORT BEARING
(FIG. N, O)**

⚠ WARNING

To avoid injury, turn the switch OFF and disconnect the saw from the power source before making any adjustments. NEVER make adjustments with the machine running.

NOTE: Make sure the blade is tensioned and tracking properly. The lower blade guides and support bearing should always be adjusted after the blade is tensioned, the tracking is adjusted, and the upper blade guides and upper support bearings are properly adjusted.

Blade guides

1. Loosen both front hex socket screws (1) with a hex wrench.
2. Move the guide blocks (2) as close to the sides of the blade (3) as possible without pinching it.
3. Using the feeler gauge, measure the spaces between the guide blocks and the blade. Adjust to 0.02".
4. Tighten the hex screws (Fig. N)
5. Loosen the side hex socket screw (4). Move the guide block support bracket (6) in or out until the blocks are just behind the saw teeth. Tighten the screw. (Fig. O)

Support bearing

6. Loosen the bearing hex socket screw (7) with the hex wrench.
7. Move the blade support bearing shaft (8) in or out until the support bearing (9) is 1/64" behind the saw blade.
8. Tighten the bearing hex socket screw. (Fig. O)
9. The back edge of the blade (3) should be positioned 1/16" to 1/8" from the right edge of the support bearing (9), as shown. (Fig. N)

Fig. N

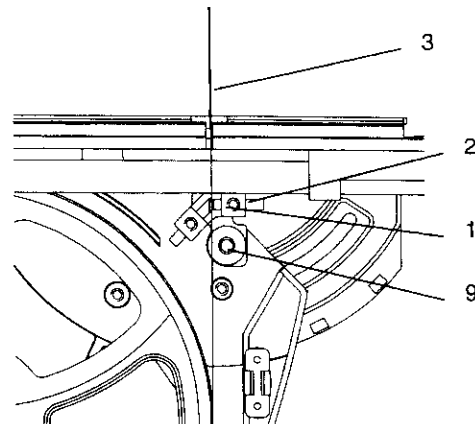
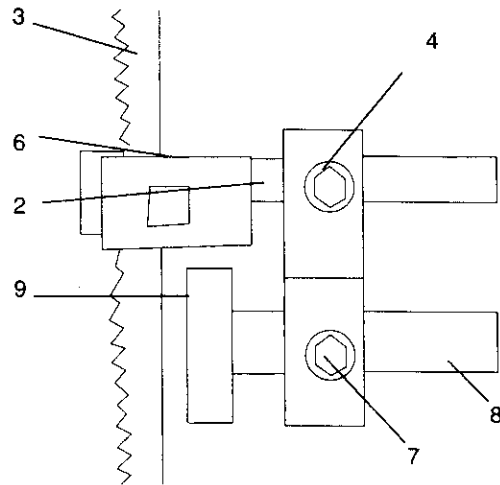

Fig. O



OPERATION

BASIC SAW OPERATIONS

“ON/OFF” SWITCH (FIG. P)

The key switch is intended to prevent unauthorized use of the band saw.

1. To turn the band saw ON insert the yellow key (1) into the key slot (2) in the center of the switch.
2. Push the key firmly into the slot, then push switch to the ON position to start the band saw.
3. To turn the band saw OFF push the switch to the down position.
4. Remove the yellow switch key, when the saw has come to a complete stop, by gently pulling it outward.

▲ WARNING

Remove the switch key whenever the saw is not in use. Place it in a safe place and out of the reach of children.

Fig. P

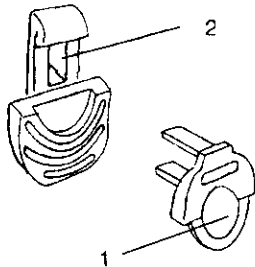

USING THE TABLE EXTENSION (FIG. Q)

NOTE:

- A. For ripping 5-3/4" ~ 7-1/2" workpiece, the extension fence has to be installed in the IN-RIP position (Fig. Q). Remove the lock handles (1) and fence. Place the fence on extension table as shown. Raise the fence to a position that just clears the table surface and secure in place using lock handles (1) for IN-RIP position.
- B. For ripping 7-1/2" ~ 12" workpiece, the extension fence has to be installed in the OUT-RIP position.
 1. Release both cam locking levers.
 2. Slide the table extension on the side your workpiece will be needing support, and tighten both cam locking levers.
 3. Slide the extension out until the correct measurement is displayed on the tube scale.

Fig. Q

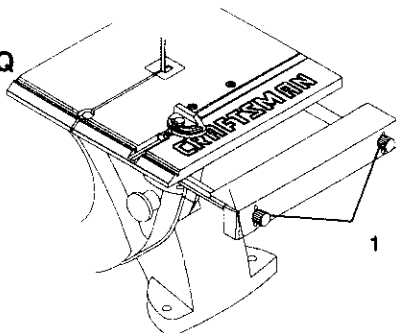

GENERAL CUTTING

▲ WARNING

For your safety, read and understand all GENERAL and SPECIFIC SAFETY INSTRUCTIONS on pages 3-5 before using the band saw.

Operating a band saw involves a certain amount of hazard. Before attempting regular work, use scrap lumber to check the settings, and to get the feel of operating the band saw. Read instructions and plan your work before cutting a workpiece.

Do not turn the power ON until after you have made all adjustments, checked that the guard is place, and turned the wheel by hand to make sure all parts work properly. Always keep the guide assembly close to your work, 1/8" above the workpiece.

Do not force the workpiece against the blade. Light contact permits easier cutting and prevents unwanted friction and heating of the blade.

Sharp saw blades need little pressure for cutting. Steadily move the workpiece against the blade without forcing it.

To avoid twisting the blade, do not turn corners or saw around corners.

A band saw is basically a "curve-cutting" saw. It is not capable of doing intricate inside cutting as can be done with a scroll saw.

It is also used for straight line operations such as crosscutting, ripping, mitering, beveling; compound cutting and resawing.

▲ WARNING

To avoid blade breakage, fire or other damage or injury, NEVER use this band saw to cut ferrous metals.

CUTTING CURVES

When cutting curves, carefully turn the workpiece so the blade follows without twisting. If the curve is so sharp that you repeatedly back up and cut new kerf, use a narrower blade, or a blade with more set (teeth further apart). When a blade has more set, the workpiece turns easier but the cut is rougher.

When changing a cut, do not withdraw the workpiece from the blade; the blade may get drawn off the wheels. To change a cut, turn the workpiece and saw out through the scrap material area.

When cutting long curves, make relief cuts as you go along.

CIRCLE CUTTING (FIG. R)

1. Adjust the guide assembly to 1/8" above the workpiece.
2. Use both hands while feeding the work into the blade. Hold the workpiece firmly against the table. Use gentle pressure. Do not force the work, allow the blade to cut.
3. The smallest diameter circle that can be cut is determined by the width of the blade. For example, a 1/4" wide blade will cut a minimum diameter of approximately 1-1/2".

Fig. R

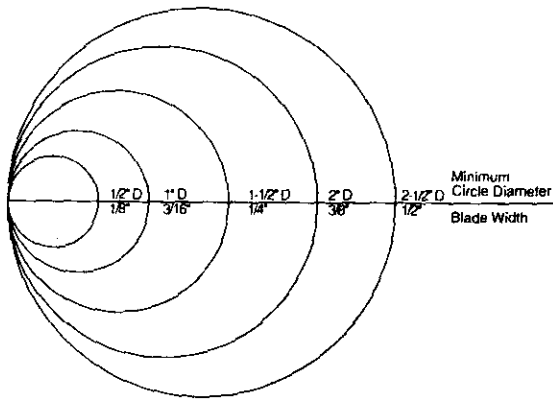

BLADE SELECTION (FIG. S)

CAUTION: Blade teeth are sharp. Use care when handling a saw blade.

For longest wear and best cutting results, use the correct blade thickness, width, and temper for the type of material you will cut.

When sawing small curves and delicate work, use narrow blades. Otherwise, use the widest blade possible. See Fig. R on page 15.

For cutting wood and similar materials with this band saw, purchase blades in widths up to 1/2", and a length of 59" to 59-1/4".

Do not cut metals with this band saw.

Common causes of blade breakage:

- Poor guide alignment and adjustment.
- Forcing or twisting a wide blade around a short radius.
- Feeding too fast.
- Dull teeth of not enough set.
- Too much blade tension.
- Setting top guide assembly too high above the workpiece.
- Lumpy or improperly finished braze or weld on the blade.
- Continuous running of blade when not cutting.

Fig. S

Operation	Recommended Blade Width (Inches)
Cross Cutting	1/4, 3/8, 1/2
Mitering	1/4, 3/8, 1/2
Beveling	1/4, 3/8, 1/2
Compound Cutting	1/4, 3/8, 1/2
Circle Cutting	See chart on this page
Curve Cutting	1/8, 1/4

MAINTENANCE

GENERAL MAINTENANCE

▲ WARNING

For your own safety, turn the switch OFF and remove the plug from the power source receptacle before maintaining, cleaning, adjusting, or lubricating your saw.

▲ WARNING

To avoid fire or toxic reaction, never use gasoline, naphtha, acetone, lacquer thinner or similar highly volatile solvents to clean the band saw.

▲ WARNING

To avoid eye injury from blowing debris, wear safety goggles when blowing out sawdust.

BAND SAW

Sawdust will accumulate under the table and base. This could cause difficulty in the movement of the table when setting up a band saw cut. Frequently blow out or vacuum up the sawdust.

Keep your band saw clean. Remove the sawdust from the inside. Vacuum or blow out frequently.

Do not allow filth to build up on the table, the guides, or the support bearings. Clean them with Craftsman Gum and Pitch Remover.

NOTE: Do not immerse the support bearings in the gum and pitch remover.

Put a thin coat of paste wax on the table so that the wood slides easily while cutting.

BLADE WHEEL TIRES

Pitch and sawdust that build up on the tires should be removed with a stiff brush or scraped off with a piece of wood.

NOTE: To avoid damaging the tires do not use a sharp knife or any kind of solvent.

When the tires become worn they should be replaced. When replacing the tires, stretch them around the wheels but do not glue them on.

MOTOR

Frequently blow or vacuum out any sawdust from the motor. Follow lubrication instruction on the motor label.

▲ WARNING

To avoid electrocution or fire, immediately replace a worn, cut or damaged power cord.

ADJUSTING THE UPPER BLADE GUIDE TRAVEL (FIG. T)

If the upper guide bar assembly will not move up and down easily or falls when the lock knob is loosened, the following adjustments should be performed.

1. Remove the guide lock knob (1)
2. Tighten or loosen the screw (2) located behind the lock knob.
3. Move the guide (3) up and down to check for smooth movement and ability to hold its position.
4. Make further adjustments to the screw as required. Properly adjusted, the guide bar should move smoothly and hold its position when released.
5. Reinstall the guide bar lock knob.

Fig. T

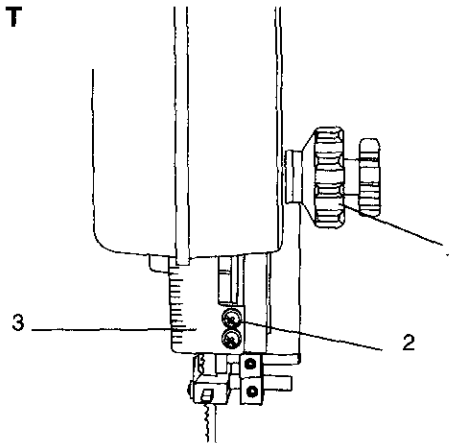

LUBRICATION

All of the bearings are packed with grease at the factory. They require no further lubrication.

CAUTION: Never put lubricants on the blade while it is spinning.

TROUBLESHOOTING GUIDE

▲ WARNING

To avoid injury from an accidental start, turn the switch OFF and remove the plug from the power source before making any adjustments.

▲ WARNING

All electrical or mechanical repairs should be done only by qualified service technicians. Contact the nearest Sears Service Center.

GENERAL

Problem	Probable Cause	Remedy
Blade does not run in the center of the upper wheel.	<ol style="list-style-type: none"> 1. Not tracking properly. 2. Defective blade. 	<ol style="list-style-type: none"> 1. Adjust tracking. See ASSEMBLY AND ADJUSTMENTS section BLADE TRACKING 2. Replace blade.
Band saw slows down when cutting	<ol style="list-style-type: none"> 1. Belt too loose. 2. Cutting too small a radius. 3. Dull blade. 4. Overloading motor. 	<ol style="list-style-type: none"> 1. Adjust belt tension. See ASSEMBLY AND ADJUSTMENTS section BLADE TENSION. 2. Stop feeding, back up the material slightly, until the band saw speeds up. 3. Replace blade. 4. Slow down, trying to cut too fast. See MOTOR TROUBLESHOOTING GUIDE on page 19 .
Blades braking	<ol style="list-style-type: none"> 1. Too much tension on the blade. 2. Kink in the blade caused by cutting too small a radius or turning the material too fast when cutting 	<ol style="list-style-type: none"> 1. Adjust tension. See ASSEMBLY AND ADJUSTMENTS section BLADE TENSION 2. Use correct cutting technique. See OPERATION section GENERAL CUTTING.
Blade dulls too quickly.	<ol style="list-style-type: none"> 1. Blade guides set too close to the teeth. 2. Cutting incorrect material. 	<ol style="list-style-type: none"> 1. Adjust upper and lower blade guides. 2. See OPERATION section BLADE SELECTION.
Band saw vibrates.	<ol style="list-style-type: none"> 1. Too much tension on motor belt. 	<ol style="list-style-type: none"> 1. Adjust according to ASSEMBLY AND ADJUSTMENTS section, INSTALL THE BELT.

MOTOR

Problem	Probable Cause	Remedy
Noisy operation.	<ol style="list-style-type: none"> 1. Incorrect belt tension. 2. Loose motor pulley. 3. Loose pulley cover. 	<ol style="list-style-type: none"> 1. Adjust tension. See ASSEMBLY AND ADJUSTMENTS section INSTALL THE BELT. 2. Readjust and tighten motor pulley set screw. 3. Readjust and tighten pulley cover mounting screws.
Motor will not start.	<ol style="list-style-type: none"> 1. Not plugged into power outlet. 2. Switch and key not in ON position. 3. Motor cord cut or abraded. 4. Plug on cord is faulty. 5. Fuse on circuit breaks open. 6. Faulty motor. 	<ol style="list-style-type: none"> 1. Plug it into the power outlet. 2. Insert key and turn the switch ON. 3. Take to Sears Service Center for new cord. 4. Take to Sears Service Center for new plug. 5. Re-set; may be too many machines on line. 6. Take to Sears Service Center for repair or replacement.
Motor	<ol style="list-style-type: none"> 1. Too many electrical machines. 2. Incorrect fuse. 3. Wheels do not rotate. 4. Undersized extension cord. 5. Short circuit. 	<ol style="list-style-type: none"> 1. Turn off other machines and try again. 2. Try time delay fuse, or go to circuit with higher rated fuse or circuit breaker. 3. Unplug and turn wheels by hand, move obstruction. 4. Use correct size extension cord; see page 5. 5. Cord, plug, or motor need repair; take to Sears Service Center for repair.
Motor fails to develop full power.	<ol style="list-style-type: none"> 1. Low line voltage. 2. Faulty motor or capacitor. 	<ol style="list-style-type: none"> 1. Check power line for proper voltage. 2. Take to Sears Service Center for evaluation.
Motor overheats.	<ol style="list-style-type: none"> 1. Overload on motor. 2. Poor ventilation of motor. Provide better air circulation. 	<ol style="list-style-type: none"> 1. Reduce load to motor, feed work slower into blade. 2. Unplug and clean out around motor; provide better air circulation. 3. Take to Sears Service Center for repair.
Motor stalls or slows	<ol style="list-style-type: none"> 1. Motor overload. 2. Low line voltage. 3. Loose wire connections. 4. Faulty motor. 	<ol style="list-style-type: none"> 1. Reduce load to motor, feed work slower into blade. 2. Check power line for proper voltage. 3. Take to Sears Service Center for repair. 4. Take to Sears Service Center for repair.
Frequent blowing of fuses or breaking of circuit	<ol style="list-style-type: none"> 1. Motor overload. 2. Overload of electrical circuit. 3. Incorrect fuse or circuit breaker. 	<ol style="list-style-type: none"> 1. Reduce load to motor, feed work slower into blade. 2. Too many electrical appliances on same circuit. 3. Have electrician upgrade service to outlet.

PARTS LIST

CRAFTSMAN 9" BAND SAW

MODEL NO. 137.214090

▲ WARNING

When servicing use only CRAFTSMAN replacement parts. Use of any other parts may create a HAZARD or cause product damage.

▲ WARNING

Any attempt to repair or replace electrical parts on this Band Saw may create a HAZARD unless repair is done by a qualified service technician. Repair service is available at your nearest Sears Service Center.

Always order by PART Number, not by key number.

Key	Part No.	Description	Qty	Key	Part No.	Description	Qty
1	300200101	MAIN BODY	1	66	300206601	CLIP	4
2	300200201	BASE	1	67	300206701	CR. HS. SCREW W/I WASHER 3/16"X1/4"	4
3	300200301	BASE	1	68	300206801	TOOTH WASHER	2
4	300200401	FLAT WASHER 3/8" X 19-2	4	69	300206901	COPPER WASHER	2
5	300200501	SPRING WASHER 3/8"	4	70	300207001	CR. HD. SCREW W/I WASHER 3/16"X1/4"	2
6	300200601	HEX. SCREW 3/8" X1"	4	71	300207101	CONDENSER	1
7	300200701	SHAFT OF LOWER WHEEL	1	72	300207201	CR. HD. SCREW W/I WASHER 3/16"X1/4"	1
8	300200801	NYLON NUT	1	73	300207301	PLATE	1
9	300200901	WASHER	4	74	300207401	CR. HD. SCREW W/I WASHER 3/16"X1/4"	4
10	300201001	P. D. BELT 9.5 -130XL	1	75	300207501	STRAIN RELIEF BUSHING	2
11	300201101	PULLEY	1	76	300207601	LABEL	1
12	300201201	POWDER COPPER	2	77	300207701	POWER LORD W/I PLUG	1
13	300201301	LOWER WHEEL	1	78	300207801	TERMINAL	2
14	300201401	WHEEL PROTECTOR	2	79	300207901	FLAT WASHER	1
15	300201501	BALL BEARING	2	80	300208001	SWITCH PLATE	1
16	300201601	C RING	2	81	300208101	CR. HD. SCREW W/I WASHER 3/16"X1/4"	2
17	300201701	FLAT WASHER	3	82	300208201	SWITCH	1
18	300201801	SELF-TAPPED SCREW	3	83	300208301	COVER	1
19	300201901	SLIDING HOLDER	1	84	300208401	HINGE	2
20	300202001	BOLT	1	85	300208501	BLIND RIVET	8
21	300202101	SPRING PIN	1	86	300208601	SPRING CLIPER	2
22	300202201	SHAFT UPPER WHEEL	1	87	300208701	KNOB	2
23	300202301	NYLON NUT	1	88	300208801	SPRING PLATE	2
24	300202401	SLIDING PLATE	1	89	300208901	CR. HD. SCREW W/I WASHER 3/16"1/4"	4
25	300202501	CR. HD. SCREW W/I WASHER 1/4" X 3/8"	4	90	300209001	TABLE	1
26	300202601	UP WHEEL	1	91	300209101	TABLE INSERT	1
27	300202701	FLAT WASHER 1/4" X16	3	92	300209201	SCREW 1/4"X3/4"	1
28	300202801	BUTTERFLY NUT 1/4"	1	93	300209301	HEX NUT 1/4"	1
29	300202901	STAR KNOB	1	94	300209401	HD. SCREW 1/4"X1-1/4"	3
30	300203001	FLAT WASHER 5/16X18-2	2	95	300209501	SPRING WASHER	3
31	300203101	SPRING	1	96	300209601	HEX. NUT 1/4"	3
32	300203201	QUICK ADJSUTING BRACKET	1	97	300209701	CARRIAGE SCREW M16X18	1
33	300203301	QUICK ADJSUTING BUTTON	1	98	300209801	FLAT WASHER M6X14X1	1
34	300203401	TURNNING KNOB	1	99	300209901	BUTTERFLY NUT M6	1
35	300203501	TURNNING BUTTON COVER	1	100	300210001	MITER GAUGE ASSEMBLY	1
36	300203601	ADJUST GUIDE	1	101	300210101	WARNING LABEL	1
37	300203701	CARRIAGE SCREW	1	102	300210201	PLASTIC BRUSH	1
38	300203801	TEETH GUIDE BOLT	1	103	300210301	BLADE GUARD	1
39	300203901	TRUNNING BUTTON	2	104	300210401	CR. HD. SCREW W/I WASHER	1
40	300204001	FLAT WASHER 1/4"X12-1	2	105	300210501	LABEL	1
41	300204101	SPRING	2	106	300210601	WARNING LABEL	1
42	300204201	KNOB	2	107	300210701	BLADE	1
43	300204301	BEARING SHAFT	2	108	300210801	HEX. WRENCH	1
44	300204401	BALL BEARING 626ZZ	2	109	300210901	INSTRUCTION MANUAL	1
45	300204501	Y TYPE BLOCK	2	110	300211001	SIDE BASE WITH CLAMP HANDLE	1
46	300204601	KEY 5X5X25	2	111	300211101	SIDE BASE (LEFT)	1
47	300204701	KEY 5X5X25	2	112	300211201	CR. RE. HD. SCREW M6-10	4
48	300204801	SCREW 1/4"X3/8"	8	113	300211301	NUT	2
49	300204901	BLADE GUARD	1	114	300211401	LEFT TUBE	1
50	300205001	WARNING STICKET	1	115	300211501	RIGHT TUBE	1
51	300205101	CR. HD. SCREW 3/16"X1/4"	2	116	300211601	CR. RE. HD. SCREW 3/16"X1/4"	1
52	300205201	TRUNNION FIXTURE BOLT	1	117	300211701	EXTENSION WING	1
53	300205301	WASHER NUT 1/4"	2	118	300211801	SIDE COVER	2
54	300205401	TABLE BRACKET	1	119	300211901	HEX. SCREW	2
55	300205501	TEETH GUIDE BOLT	1	120	300212001	RIP FENCE	1
56	300205601	NYLON WASHER	1	121	300212101	KNOB	2
57	300205701	WAVE WASHER	1	122	300212201	SCALE	1
58	300205801	SET SCREW	1	123	300212301	LABEL	1
59	300205901	POINTER	1	124	300212401	LABEL	1
60	300206001	CR. HS. SCREW W/I WASHER 3/16"X1/4"	1	125	300215001	LABEL	1
61	300206101	MOTOR	1				
62	300206201	PULLEY	1				
63	300206301	SCREW M4X10L	2				
64	300206401	90 CONNECTOR	1				
65	300206501	BLOWER	1				

9" BAND SAW

MODEL NO. 137.214090

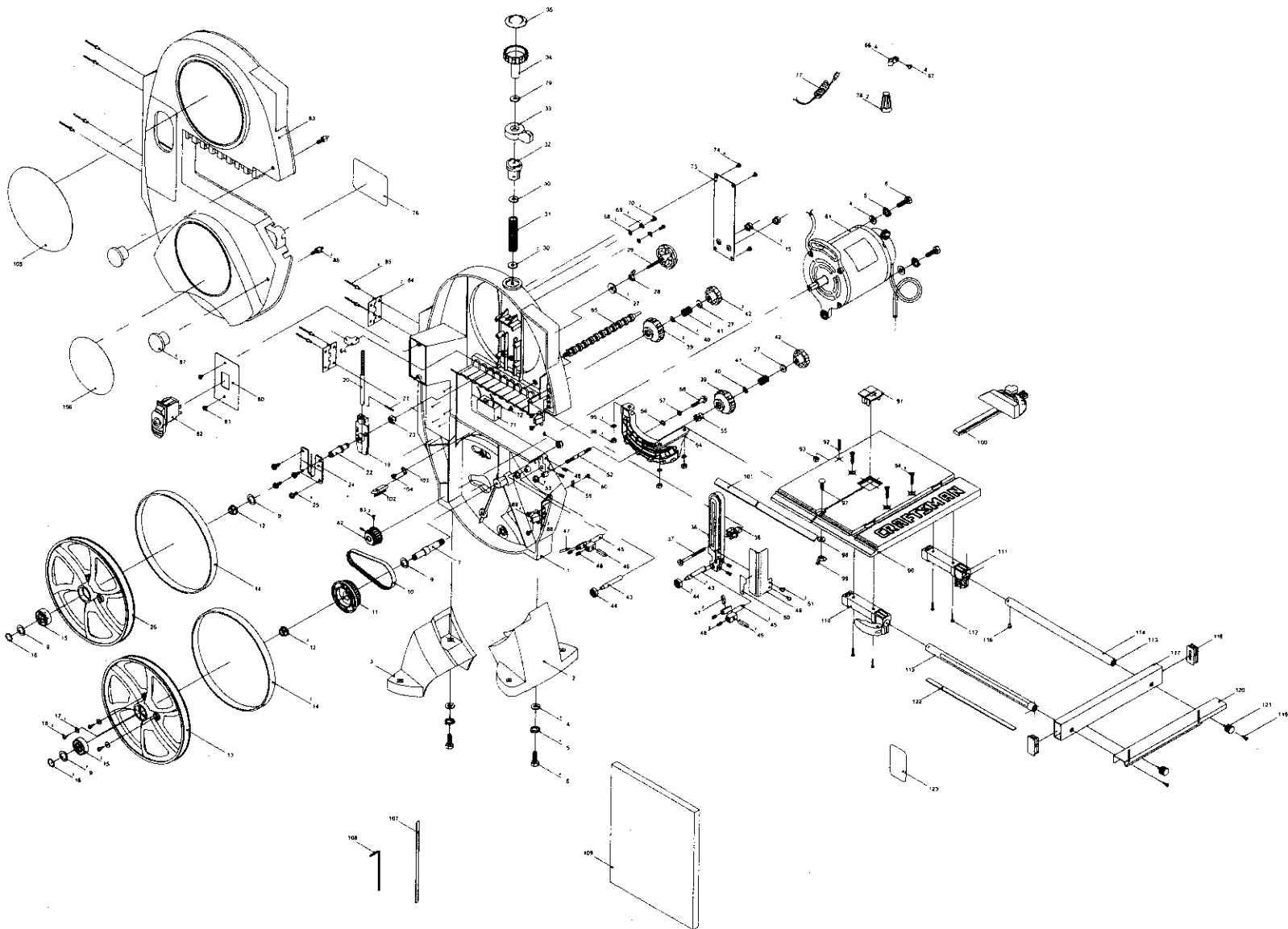

Your Home

For repair – **in your home** – of all major brand appliances, lawn and garden equipment, or heating and cooling systems, **no matter who made it, no matter who sold it!**

For the replacement parts, accessories and Operator's Manuals that you need to do-it-yourself.

For Sears professional installation of home appliances and items like garage door openers and water heaters.

1-800-4-MY-HOME® (1-800-469-4663)

Call anytime, day or night (U.S.A. and Canada)

www.sears.com www.sears.ca

Our Home

For repair of carry-in items like vacuums, lawn equipment, and electronics, call or go on-line for the location of your nearest **Sears Parts & Repair Center.**

1-800-488-1222

Call anytime, day or night (U.S.A. only)

www.sears.com

To purchase a protection agreement on a product serviced by Sears:

1-800-827-6655 (U.S.A.)

1-800-361-6665 (Canada)

Para pedir servicio de reparación a domicilio, y para ordenar piezas:

1-888-SU-HOGARSM

(1-888-784-6427)

Au Canada pour service en français:

1-800-LE-FOYER^{MC}

(1-800-533-6937)

www.sears.ca

SEARS

® Registered Trademark / ™ Trademark / ™ Service Mark of Sears, Roebuck and Co.

® Marca Registrada / ™ Marca de Fábrica / ™ Marca de Servicio de Sears, Roebuck and Co.

MC Marque de commerce / MD Marque déposée de Sears, Roebuck and Co.

© Sears, Roebuck and Co.