

Owner's Manual



LAWN TRACTOR

21.0 HP, 48" Mower

Electric Start

Automatic Transmission

Model No.

917.273281

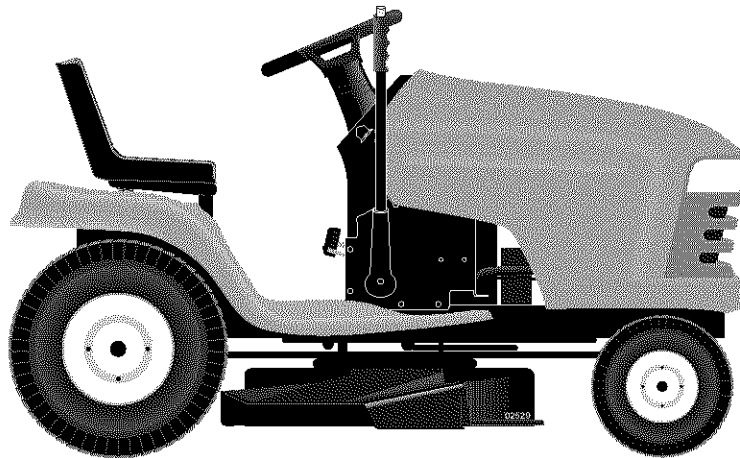

This product has a low emission engine which operates differently from previously built engines. Before you start the engine, read and understand this Owner's Manual.

IMPORTANT:

Read and follow all Safety Rules and Instructions before operating this equipment.

For answers to your questions about this product, Call:

1-800-659-5917
Sears Craftsman Help Line
5 am - 5 pm, Mon - Sat

Sears, Roebuck and Co., Hoffman Estates, IL 60179 U.S.A.
Visit our Craftsman website: www.sears.com/craftsman

TABLE OF CONTENTS

| | | | |
|------------------------------|----|------------------------------|------------|
| Warranty | 2 | Service and Adjustments..... | 19 |
| Safety Rules | 3 | Storage | 27 |
| Product Specifications | 5 | Troubleshooting | 28 |
| Assembly/Pre-Operation | 7 | Repair Parts..... | 32 |
| Operation..... | 9 | Sears Service | Back Cover |
| Maintenance Schedule | 15 | | |
| Maintenance | 15 | | |

WARRANTY

LIMITED WARRANTY ON CRAFTSMAN RIDING EQUIPMENT

For two (2) years from the date of purchase, if this Craftsman Riding Equipment is maintained, lubricated and tuned up according to the instructions in the owner's manual, Sears will repair or replace free of charge any parts that are found to be defective in material or workmanship according to the guidelines of coverage listed below. Sears will also provide free labor for these applicable warranted parts for the two full years. During the first 30 days of purchase, there will be no charges to service the product at your home for issues covered by this warranty. (See exclusions below). For your convenience, IN HOME warranty service will still be available after the first 30 days of purchase, but a trip charge will apply. This charge will be waived if the Craftsman product is dropped off at an authorized Sears location. For the nearest authorized Sears location, please call 1-800-4-MY-HOME®. This warranty applies only while this product is within the United States.

This Warranty does not cover:

- Expendable items which become worn during normal use, including but not limited to blades, spark plugs, air cleaners, belts, and oil filters.
- Standard Maintenance Servicing, oil changes, or tune-ups
- Tire replacement or repair caused by punctures from outside objects, such as nails, thorns, stumps, or glass.
- Repairs necessary because of operator abuse, including but not limited to, damage caused by towing objects beyond the capability of the riding equipment, impacting objects that bend the frame or crankshaft, or over-speeding the engine.
- Repairs necessary because of operator negligence, including but not limited to, electrical and mechanical damage caused by improper storage, failure to use the proper grade and amount of engine oil, failure to keep the deck clear of flammable debris, or failure to maintain the equipment according to the instructions contained in the owner's manual.
- Engine (fuel system) cleaning or repairs caused by fuel determined to be contaminated or oxidized (stale). In general, fuel should be used within 30 days of its purchase date.
- Normal deterioration and wear of the exterior finishes, or product label replacement.
- Riding equipment used for commercial or rental purposes.

LIMITED WARRANTY ON BATTERY

For ninety (90) days from date of purchase, if any battery included with this riding equipment proves defective in material or workmanship and our testing determines the battery will not hold a charge, Sears will replace the battery at no charge. During the first 30 days of purchase, there will be no charges to replace the battery at your HOME. After the first 30 days, for your convenience, IN-HOME warranty service will still be available but a trip charge will apply. This charge will be waived if the Craftsman product is dropped off at an authorized Sears location. For the nearest authorized Sears location, please call 1-800-4-MY-HOME®.

This battery warranty applies only while this product is within the United States.

This warranty gives you specific legal rights, and you may also have other rights, which vary, from state to state.

Sears, Roebuck and Co., Dept. 817WA, Hoffman Estates, IL 60179

SAFETY RULES

IMPORTANT: This cutting machine is capable of amputating hands and feet and throwing objects. Failure to observe the following safety instructions could result in serious injury or death.

⚠WARNING: In order to prevent accidental starting when setting up, transporting, adjusting or making repairs, always disconnect spark plug wire and place wire where it cannot contact spark plug.

⚠WARNING: Do not coast down a hill in neutral, you may lose control of the tractor.

⚠WARNING: Tow only the attachments that are recommended by and comply with specifications of the manufacturer of your tractor. Use common sense when towing. Operate only at the lowest possible speed when on a slope. Too heavy of a load, while on a slope, is dangerous. Tires can lose traction with the ground and cause you to lose control of your tractor.

⚠WARNING: Engine exhaust, some of its constituents, and certain vehicle components contain or emit chemicals known to the State of California to cause cancer and birth defects or other reproductive harm.

⚠WARNING: Battery posts, terminals and related accessories contain lead and lead compounds, chemicals known to the State of California to cause cancer and birth defects or other reproductive harm.

Wash hands after handling.

I. GENERAL OPERATION

- Read, understand, and follow all instructions in the manual and on the machine before starting.
- Only allow responsible adults, who are familiar with the instructions, to operate the machine.
- Clear the area of objects such as rocks, toys, wire, etc., which could be picked up and thrown by the blade.
- Be sure the area is clear of other people before mowing. Stop machine if anyone enters the area.
- Never carry passengers.
- Do not mow in reverse unless absolutely necessary. Always look down and behind before and while backing.

- Be aware of the mower discharge direction and do not point it at anyone. Do not operate the mower without either the entire grass catcher or the guard in place.
- Slow down before turning.
- Never leave a running machine unattended. Always turn off blades, set parking brake, stop engine, and remove keys before dismounting.
- Turn off blades when not mowing.
- Stop engine before removing grass catcher or unclogging chute.
- Mow only in daylight or good artificial light.
- Do not operate the machine while under the influence of alcohol or drugs.
- Watch for traffic when operating near or crossing roadways.
- Use extra care when loading or unloading the machine into a trailer or truck.
- Data indicates that operators, age 60 years and above, are involved in a large percentage of riding mower-related injuries. These operators should evaluate their ability to operate the riding mower safely enough to protect themselves and others from serious injury.
- Keep machine free of grass, leaves or other debris build-up which can touch hot exhaust / engine parts and burn. Do not allow the mower deck to plow leaves or other debris which can cause build-up to occur. Clean any oil or fuel spillage before operating or storing the machine. Allow machine to cool before storage.

II. SLOPE OPERATION

Slopes are a major factor related to loss-of-control and tipover accidents, which can result in severe injury or death. All slopes require extra caution. If you cannot back up the slope or if you feel uneasy on it, do not mow it.

SAFETY RULES

DO:

- Mow up and down slopes, not across.
- Remove obstacles such as rocks, tree limbs, etc.
- Watch for holes, ruts, or bumps. Uneven terrain could overturn the machine. *Tall grass can hide obstacles.*
- Use slow speed. Choose a low gear so that you will not have to stop or shift while on the slope.
- Follow the manufacturer's recommendations for wheel weights or counterweights to improve stability.
- Use extra care with grass catchers or other attachments. These can change the stability of the machine.
- Keep all movement on the slopes *slow* and *gradual*. Do not make sudden changes in speed or direction.
- Avoid starting or stopping on a slope. If tires lose traction, disengage the blades and proceed slowly *straight* down the slope.

DO NOT:

- *Do not* turn on slopes unless necessary, and then, turn slowly and gradually downhill, if possible.
- *Do not* mow near drop-offs, ditches, or embankments. The mower could suddenly turn over if a wheel is over the edge of a cliff or ditch, or if an edge caves in.
- *Do not* mow on wet grass. Reduced traction could cause sliding.
- *Do not* try to stabilize the machine by putting your foot on the ground.
- *Do not* use grass catcher on steep slopes.

III. CHILDREN

Tragic accidents can occur if the operator is not alert to the presence of children. Children are often attracted to the machine and the mowing activity. *Never* assume that children will remain where you last saw them.

- Keep children out of the mowing area and under the watchful care of another responsible adult.
- Be alert and turn machine off if children enter the area.
- Before and when backing, look behind and *down* for small children.

- Never carry children. They may fall off and be seriously injured or interfere with safe machine operation.
- Never allow children to operate the machine.
- Use extra care when approaching blind corners, shrubs, trees, or other objects that may obscure vision.

IV. SERVICE

- Use extra care in handling gasoline and other fuels. They are flammable and vapors are explosive.
 - Use only an approved container.
 - Never remove gas cap or add fuel with the engine running. Allow engine to cool before refueling. Do not smoke.
 - Never refuel the machine indoors.
 - Never store the machine or fuel container inside where there is an open flame, such as a water heater.
- Never run a machine inside a closed area.
- Keep nuts and bolts, especially blade attachment bolts, tight and keep equipment in good condition.
- Never tamper with safety devices. Check their proper operation regularly.
- Keep machine free of grass, leaves, or other debris build-up. Clean oil or fuel spillage. Allow machine to cool before storing.
- Stop and inspect the equipment if you strike an object. Repair, if necessary, before restarting.
- Never make adjustments or repairs with the engine running.
- Grass catcher components are subject to wear, damage, and deterioration, which could expose moving parts or allow objects to be thrown. Frequently check components and replace with manufacturer's recommended parts, when necessary.
- Mower blades are sharp and can cut. Wrap the blade(s) or wear gloves, and use extra caution when servicing them.
- Check brake operation frequently. Adjust and service as required.

SAFETY RULES

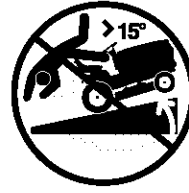

- Be sure the area is clear of other people before mowing. Stop machine if anyone enters the area.
- Never carry passengers or children even with the blades off.
- Do not mow in reverse unless absolutely necessary. Always look down and behind before and while backing.
- Never carry children. They may fall off and be seriously injured or interfere with safe machine operation.
- Keep children out of the mowing area and under the watchful care of another responsible adult.
- Be alert and turn machine off if children enter the area.
- Before and when backing, look behind and down for small children.
- Mow up and down slopes (15° Max), not across.
- Remove obstacles such as rocks, tree limbs, etc.
- Watch for holes, ruts, or bumps. Uneven terrain could overturn the machine. Tall grass can hide obstacles.
- Use slow speed. Choose a low gear so that you will not have to stop or shift while on the slope.
- Avoid starting or stopping on a slope. If tires lose traction, disengage the blades and proceed slowly straight down the slope.
- If machine stops while going uphill, disengage blades, shift into reverse and back down slowly.
- Do not turn on slopes unless necessary, and then, turn slowly and gradually downhill, if possible.

PRODUCT SPECIFICATIONS

| | |
|-----------------------------|---|
| Gasoline Capacity and Type: | 4 Gallons Unleaded Regular |
| Oil Type (API-SF-SJ): | SAE 30 (above 32°F) SAE 5W-30 (below 32°F) |
| Oil Capacity: | W/Filter: 4.0 Pints W/O Filter: 3.75 Pints |
| Spark Plug: (Gap: .040") | Champion QC12YC |
| Ground Speed (MPH): | Forward: 0 – 5.5 Reverse: 0 – 2.4 |
| Tire Pressure: | Front: 14 PSI Rear: 10 PSI |
| Charging System: | 16 Amps @ 3600 RPM |
| Battery: | Amp/Hr: 35 Min. CCA: 280 Case size: U1R |
| Blade Bolt Torque: | 45-55 Ft. Lbs. |

CONGRATULATIONS

on your purchase of a new tractor. It has been designed, engineered and manufactured to give you the best possible dependability and performance. Should you experience any problem you cannot easily remedy, please contact a Sears or other qualified service center. We have competent, well-trained technicians and the proper tools to service or repair this tractor. Please read and retain this manual. The instructions will enable you to assemble and maintain your tractor properly. Always observe the "SAFETY RULES".

CUSTOMER RESPONSIBILITIES

- Read and observe the safety rules.
- Follow a regular schedule in maintaining, caring for and using your tractor.
- Follow the instructions under "Maintenance" and "Storage" sections of this owner's manual.

⚠WARNING: This tractor is equipped with an internal combustion engine and should not be used on or near any unimproved forest-covered, brush-covered or grass-covered land unless the engine's exhaust system is equipped with a spark arrester meeting applicable local or state laws (if any). If a spark arrester is used, it should be maintained in effective working order by the operator.

In the state of California the above is required by law (Section 4442 of the California Public Resources Code). Other states may have similar laws. Federal laws apply on federal lands. A spark arrester for the muffler is available through your nearest Sears service center (See REPAIR PARTS section of this manual).

REPAIR PROTECTION AGREEMENTS

Congratulations on making a smart purchase. Your new Craftsman® product is designed and manufactured for years of dependable operation. But like all products, it may require repair from time to time. That's when having a Repair Protection Agreement can save you money and aggravation. *Purchase a Repair Protection Agreement now and protect yourself from unexpected hassle and expense.*

Here's what's included in the Agreement:

- Expert service by our 12,000 professional repair specialists.
- Unlimited service and no charge for parts and labor on all covered repairs.
- Product replacement if your covered product can't be fixed.
- Discount of 10% from regular price of service and service-related parts not covered by the agreement; also, 10% off regular price of preventive maintenance check.
- Fast help by phone – phone support from a Sears technician on products requiring in-home repair, plus convenient repair scheduling.

Once you purchase the Agreement, a simple phone call is all that it takes for you to schedule service. You can call anytime day or night, or schedule a service appointment online.

Sears has over 12,000 professional repair specialists, who have access to over 4.5 million quality parts and accessories.

That's the kind of professionalism you can count on to help prolong the life of your new purchase for years to come. Purchase your Repair Protection Agreement today!

Some limitations and exclusions apply.

For prices and additional information call 1-800-827-6655.

SEARS INSTALLATION SERVICE

For Sears professional installation of home appliances, garage door openers, water heaters, and other major home items, in the U.S.A. call 1-800-4-MY-HOME®

PARTS BAG CONTENTS

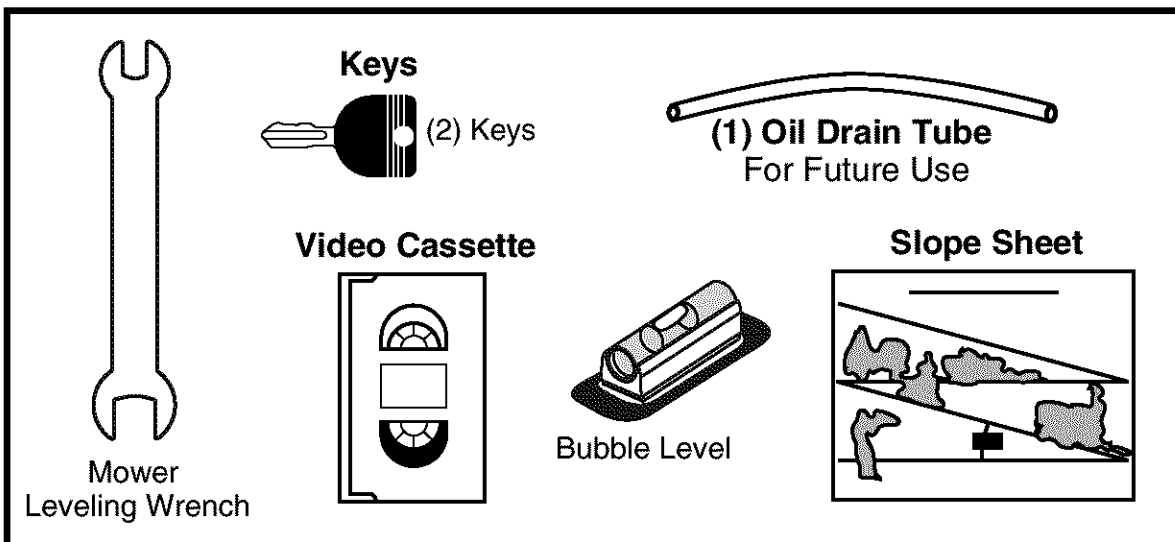

ASSEMBLY/PRE-OPERATION

Your new tractor has been assembled at the factory. Review the video cassette before you begin.

When right or left hand is mentioned in this manual, it means, from your point of view, when you are in the operating position (seated behind the steering wheel).

TO REMOVE TRACTOR FROM CARTON

UNPACK CARTON

1. Cut along dotted lines on all four panels of carton. Remove end panels and lay side panels flat.
2. Remove packing materials.
3. Remove protective materials from tractor hood and grille.

IMPORTANT: Check for and remove any staples in skid that may puncture tires where tractor is to roll off skid.

HOW TO SET UP YOUR TRACTOR

CHECK BATTERY

1. Lift hood to raised position.

NOTE: If this battery is put into service after month and year indicated on label (label located between terminals) charge battery for minimum of one hour at 6-10 amps. (See "BATTERY" in Maintenance section of this manual for charging instructions).

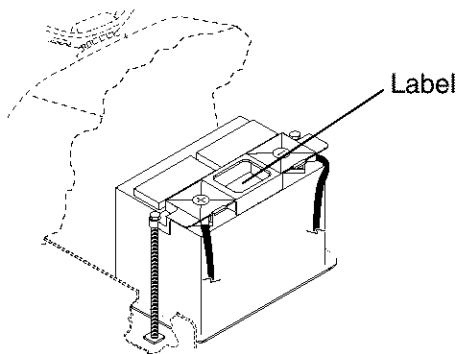

ADJUST SEAT

1. Raise seat and loosen adjustment knob.
2. Lower seat into operating position and sit in seat.
3. Slide seat until a comfortable position is reached which allows you to press clutch/brake pedal all the way down.
4. Get off seat without moving its adjusted position.
5. Raise seat and tighten adjustment knob securely.

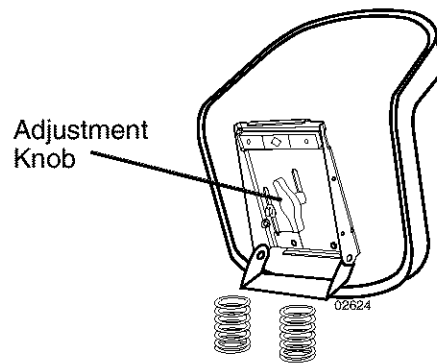

NOTE: You may now roll or drive your tractor off the skid. Follow the appropriate instruction below to remove the tractor from the skid.

TO ROLL TRACTOR OFF SKID (See Operation section for location and function of controls)

1. Press lift lever plunger and raise attachment lift lever to its highest position.
2. Release parking brake by depressing brake pedal.
3. Place freewheel control in "transmission disengaged" position (See "TO TRANSPORT" in the Operation section of this manual).
4. Roll tractor forward off skid.

TO DRIVE TRACTOR OFF SKID (See Operation section for location and function of controls)

WARNING: Before starting, read, understand and follow all instructions in the Operation section of this manual. Be sure tractor is in a well-ventilated area. Be sure the area in front of tractor is clear of other people and objects.

1. Be sure all the above assembly steps have been completed.
2. Check engine oil level and fill fuel tank with gasoline.
3. Place freewheel control in "transmission engaged" position. (See "TO TRANSPORT" in the Operation section of this manual).
4. Sit on seat in operating position, depress brake pedal and set the parking brake.
5. Press lift lever plunger and raise attachment lift lever to its highest position.

6. Start the engine. After engine has started, move throttle control to idle position.
7. Release parking brake.
8. Slowly depress forward drive pedal and drive tractor off skid.
9. Apply brake to stop tractor and set parking brake.
10. Turn ignition key to "STOP" position. Continue with the instructions that follow.

CHECK TIRE PRESSURE

The tires on your tractor were overinflated at the factory for shipping purposes. Correct tire pressure is important for best cutting performance.

- Reduce tire pressure to PSI shown in "PRODUCT SPECIFICATIONS" section of this manual.

CHECK DECK LEVELNESS

For best cutting results, mower housing should be properly leveled. See "TO LEVEL MOWER HOUSING" in the Service and Adjustments section of this manual.

CHECK FOR PROPER POSITION OF ALL BELTS

See the figures that are shown for replacing motion and mower blade drive belts in the Service and Adjustments section of this manual. Verify that the belts are routed correctly.

CHECK BRAKE SYSTEM

After you learn how to operate your tractor, check to see that the brake is properly adjusted. See "TO ADJUST BRAKE" in the Service and Adjustments section of this manual.

✓CHECKLIST

Before you operate your new tractor, we wish to assure that you receive the best performance and satisfaction from this Quality Product.

Please review the following checklist:

- ✓ All assembly instructions have been completed.
- ✓ No remaining loose parts in carton.
- ✓ Battery is properly prepared and charged. (Minimum 1 hour at 6 amps).
- ✓ Seat is adjusted comfortably and tightened securely.
- ✓ All tires are properly inflated. (For shipping purposes, the tires were overinflated at the factory).
- ✓ Be sure mower deck is properly leveled side-to-side/front-to-rear for best cutting results. (Tires must be properly inflated for leveling).
- ✓ Check mower and drive belts. Be sure they are routed properly around pulleys and inside all belt keepers.
- ✓ Check wiring. See that all connections are still secure and wires are properly clamped.
- ✓ Before driving tractor, be sure freewheel control is in "transmission engaged" position (see "To Transport" in the Operation section of this manual).

While learning how to use your tractor, pay extra attention to the following important items:

- ✓ Engine oil is at proper level.
- ✓ Fuel tank is filled with fresh, clean, regular unleaded gasoline.
- ✓ Become familiar with all controls, their location and function. Operate them before you start the engine.
- ✓ Be sure brake system is in safe operating condition.
- ✓ It is important to purge the transmission before operating your tractor for the first time. Follow proper starting and transmission purging instructions (See "TO START ENGINE" and "PURGE TRANSMISSION" in the Operation section of this manual).

OPERATION

These symbols may appear on your tractor or in literature supplied with the product. Learn and understand their meaning.

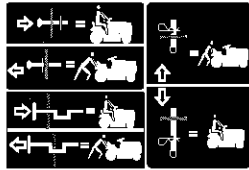
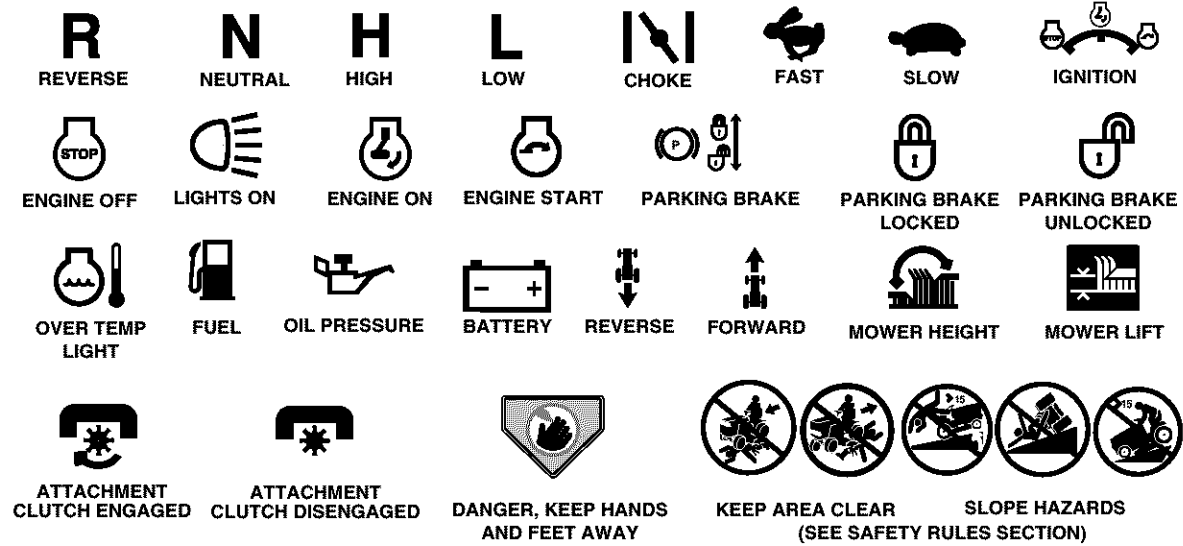

FREE WHEEL
(Automatic Models only)



Failure to follow instructions could result in serious injury or death. The safety alert symbol is used to identify safety information about hazards which can result in death, serious injury and/or property damage.



DANGER indicates a hazard which, if not avoided, will result in death or serious injury.



WARNING indicates a hazard which, if not avoided, could result in death or serious injury.



CAUTION indicates a hazard which, if not avoided, might result in minor or moderate injury.

CAUTION when used **without** the alert symbol, indicates a situation that **could result in damage to the tractor and/or engine.**



HOT SURFACES indicates a hazard which, if not avoided, could result in death, serious injury and/or property damage.



FIRE indicates a hazard which, if not avoided, could result in death, serious injury and/or property damage.

KNOW YOUR TRACTOR

READ THIS OWNER'S MANUAL AND SAFETY RULES BEFORE OPERATING YOUR TRACTOR

Compare the illustrations with your tractor to familiarize yourself with the locations of various controls and adjustments. Save this manual for future reference.

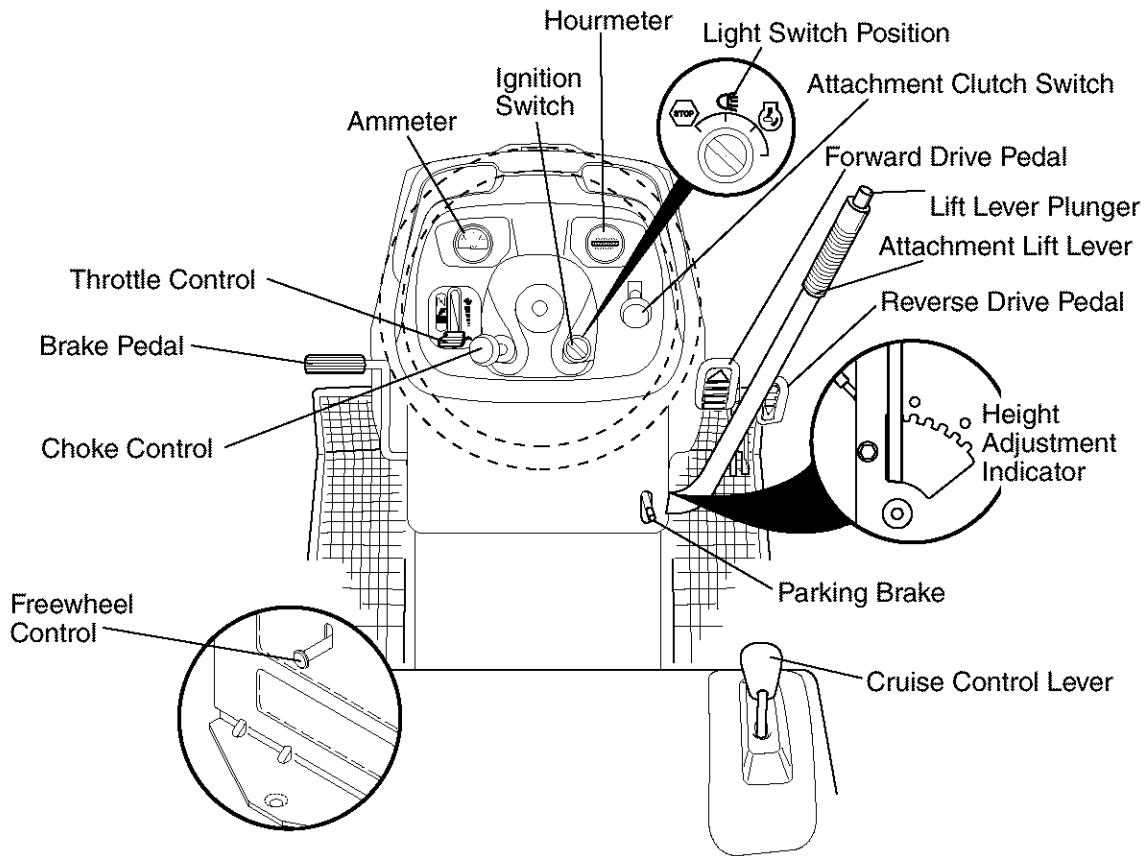

Our tractors conform to the safety standards of the American National Standards Institute.

ATTACHMENT CLUTCH SWITCH - Used to engage the mower blades, or other attachments mounted to your tractor.

LIGHT SWITCH POSITION - Turns the headlights on and off.

THROTTLE CONTROL - Used to control engine speed.

CHOKE CONTROL - Used when starting a cold engine.

BRAKE PEDAL - Used for braking the tractor and starting the engine.

FREEWHEEL CONTROL - Disengages transmission for pushing or slowly towing the tractor with the engine off.

ATTACHMENT LIFT LEVER - Used to raise, lower and adjust the mower deck or other attachments mounted to your tractor.

LIFT LEVER PLUNGER - Used to release attachment lift lever when changing its position.

IGNITION SWITCH - Used for starting and stopping the engine.

AMMETER - Indicates battery charging (+) or discharging (-).

PARKING BRAKE - Locks clutch/brake into the brake position.

FORWARD DRIVE PEDAL - Used for forward movement of tractor.

REVERSE DRIVE PEDAL - Used for reverse movement of tractor.

CRUISE CONTROL LEVER - Used to set forward movement of tractor at desired speed without holding the forward drive pedal.

HOURMETER - Indicates hours of operation.



The operation of any tractor can result in foreign objects thrown into the eyes, which can result in severe eye damage. Always wear safety glasses or eye shields while operating your tractor or performing any adjustments or repairs. We recommend standard safety glasses or a wide vision safety mask worn over spectacles.

HOW TO USE YOUR TRACTOR TO SET PARKING BRAKE

Your tractor is equipped with an operator presence sensing switch. When engine is running, any attempt by the operator to leave the seat without first setting the parking brake will shut off the engine.

1. Depress brake pedal all the way down and hold.
2. Pull parking brake lever up and release pressure from brake pedal. Pedal should remain in brake position. Make sure parking brake will hold tractor secure.

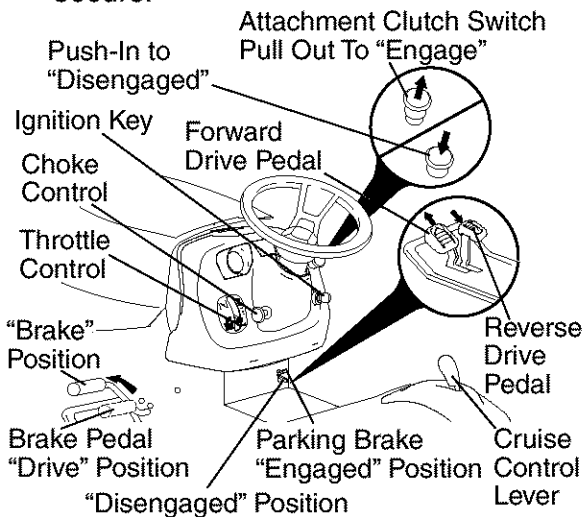

STOPPING

MOWER BLADES -

- To stop mower blades, push attachment clutch switch in to disengaged position.

GROUND DRIVE -

- To stop ground drive, depress brake pedal all the way down.

IMPORTANT: Forward and reverse drive pedals return to neutral position when not depressed.

ENGINE -

- Move throttle control to slow position.
NOTE: Failure to move throttle control to slow position to allow engine to idle before stopping may cause engine to "backfire".
- Turn ignition key to "STOP" position and remove key. Always remove key when leaving tractor to prevent unauthorized use.
- Never use choke to stop engine.

IMPORTANT: Leaving the ignition switch in any position other than "STOP" will cause the battery to discharge and go dead.

NOTE: Under certain conditions when tractor is standing idle with the engine running, hot engine exhaust gases may cause "browning" of grass. To eliminate this possibility, always stop engine when stopping tractor on grass areas.

CAUTION: Always stop tractor completely, as described above, before leaving the operator's position.

THROTTLE CONTROL

Always operate engine at full throttle.

- Operating engine at less than full throttle reduces the battery charging rate.
- Full throttle offers the best bagging and mower performance.

TO USE CHOKE CONTROL

Use choke control whenever you are starting a cold engine. Do not use to start a warm engine.

- To engage choke control, pull knob out. Slowly push knob in to disengage.

TO MOVE FORWARD AND BACKWARD

The direction and speed of movement is controlled by the forward and reverse drive pedals.

1. Start tractor and release parking brake.
2. Slowly depress forward or reverse drive pedal to begin movement. Ground speed increases the further down the pedal is depressed.

TO USE CRUISE CONTROL

The cruise control feature can be used for forward travel only.

SYSTEM CHARACTERISTICS

The cruise control should only be used while mowing or transporting on relatively smooth, straight surfaces. Other conditions such as trimming at slow speeds may cause the cruise control to disengage. Do not use the cruise control on slopes, rough terrain or while trimming or turning.

1. With forward drive pedal depressed to desired speed, move cruise control lever forward to "SET" position and hold while lifting your foot off the pedal, then release the cruise control lever.

To disengage the cruise control, pull the lever backward to "OFF" position, or fully depress the brake pedal.

TO ADJUST MOWER CUTTING HEIGHT

The position of the attachment lift lever determines the cutting height.

- Grasp lift lever.
- Press plunger with thumb and move lever to desired position.

The cutting height range is approximately 1-1/2 to 4". The heights are measured from the ground to the blade tip with the engine not running.

These heights are approximate and may vary depending upon soil conditions, height of grass and types of grass being mowed.

- The average lawn should be cut to approximately 2-1/2 inches during the cool season and to over 3 inches during hot months. For healthier and better looking lawns, mow often and after moderate growth.
- For best cutting performance, grass over 6 inches in height should be mowed twice. Make the first cut relatively high; the second to desired height.

TO ADJUST GAUGE WHEELS

Gauge wheels are properly adjusted when they are slightly off the ground when mower is at the desired cutting height in operating position. Gauge wheels then keep the deck in proper position to help prevent scalping in most terrain conditions.

NOTE: Be sure tractor is on a flat level surface.

1. Lower mower and adjust mower to desired cutting height.
2. Remove retainer spring and clevis pin which secure each gauge wheel bar.
3. Lower gauge wheels to ground. Raise gauge wheels slightly to align holes in bracket and gauge wheel bar and insert clevis pin. Gauge wheels should be slightly off the ground.
4. Replace retainer spring into clevis pin.
5. Be sure all gauge wheels are in the same setting.

IMPORTANT: Be sure to readjust gauge wheels if you change the cutting height of the mower deck.

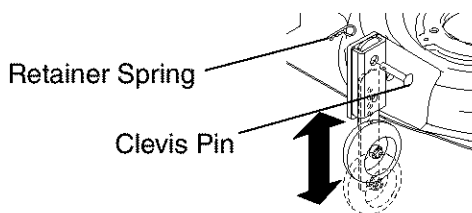

TO OPERATE MOWER

Your tractor is equipped with an operator presence sensing switch. Any attempt by the operator to leave the seat with the engine running and the attachment clutch engaged will shut off the engine.

1. Select desired height of cut.
2. Start mower blades by engaging attachment clutch control.

TO STOP MOWER BLADES - disengage attachment clutch control.

CAUTION: Do not operate the mower without either the entire grass catcher, on mowers so equipped, or the deflector shield in place.

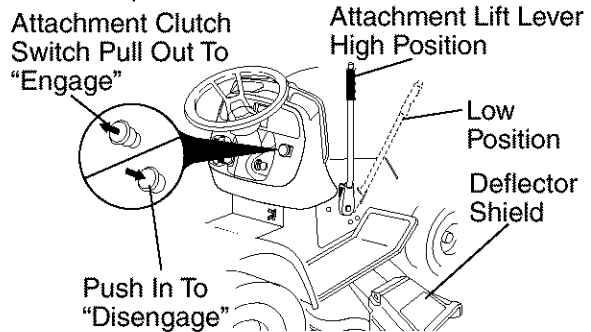

TO OPERATE ON HILLS

WARNING: Do not drive up or down hills with slopes greater than 15° and do not drive across any slope. Use the slope guide at the back of this manual.

- Choose the slowest speed before starting up or down hills.
- Avoid stopping or changing speed on hills.
- If stopping is absolutely necessary, push brake pedal quickly to brake position and engage parking brake.
- To restart movement, slowly release parking brake and brake pedal.
- Slowly depress appropriate drive pedal to slowest setting.
- Make all turns slowly.

TO TRANSPORT

When pushing or towing your tractor, be sure to disengage transmission by placing freewheel control in freewheeling position. Freewheel control is located at the rear drawbar of tractor.

1. Raise attachment lift to highest position with attachment lift control.
 2. Pull freewheel control out and down into the slot and release so it is held in the disengaged position.
- Do not push or tow tractor at more than two (2) MPH.
 - To re-engage transmission, reverse above procedure.

Transmission Engaged

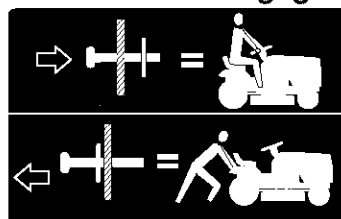

Transmission Disengaged

NOTE: To protect hood from damage when transporting your tractor on a truck or a trailer, be sure hood is closed and secured to tractor. Use an appropriate means of tying hood to tractor (rope, cord, etc.).

TOWING CARTS AND OTHER ATTACHMENTS

Tow only the attachments that are recommended by and comply with specifications of the manufacturer of your tractor. Use common sense when towing. Too heavy of a load, while on a slope, is dangerous. Tires can lose traction with the ground and cause you to lose control of your tractor.

BEFORE STARTING THE ENGINE CHECK ENGINE OIL LEVEL

The engine in your tractor has been shipped, from the factory, already filled with summer weight oil.

1. Check engine oil with tractor on level ground.
 2. Remove oil fill cap/dipstick and wipe clean, reinsert the dipstick and screw cap tight, wait for a few seconds, remove and read oil level. If necessary, add oil until "FULL" mark on dipstick is reached. Do not overfill.
- For cold weather operation you should change oil for easier starting (See the oil viscosity chart in the Maintenance section of this manual).
 - To change engine oil, see the Maintenance section in this manual.

ADD GASOLINE

- Fill fuel tank to bottom of tank filler neck. Do not overfill. Use fresh, clean, regular unleaded gasoline with a minimum of 87 octane. (Use of leaded gasoline will increase carbon and lead oxide deposits and reduce valve life). Do not mix oil with gasoline. Purchase fuel in quantities that can be used within 30 days to assure fuel freshness.

CAUTION: Wipe off any spilled oil or fuel. Do not store, spill or use gasoline near an open flame.

IMPORTANT: When operating in temperatures below 32°F(0°C), use fresh, clean winter grade gasoline to help insure good cold weather starting.

CAUTION: Alcohol blended fuels (called gasohol or using ethanol or methanol) can attract moisture which leads to separation and formation of acids during storage. Acidic gas can damage the fuel system of an engine while in storage.

To avoid engine problems, the fuel system should be emptied before storage of 30 days or longer. Drain the gas tank, start the engine and let it run until the fuel lines and carburetor are empty. Use fresh fuel next season. See Storage Instructions for additional information.

Never use engine or carburetor cleaner products in the fuel tank or permanent damage may occur.

TO START ENGINE

When starting the engine for the first time or if the engine has run out of fuel, it will take extra cranking time to move fuel from the tank to the engine.

1. Be sure freewheel control is in the transmission engaged position.
2. Sit on seat in operating position, depress brake pedal and set parking brake.
3. Move attachment clutch to disengaged position.
4. Move throttle control to fast position
5. Pull choke control out for a cold engine start attempt. For a warm engine start attempt the choke control may not be needed.

NOTE: Before starting, read the warm and cold starting procedures below.

6. Insert key into ignition and turn key clockwise to start position and release key as soon as engine starts. Do not run starter continuously for more than fifteen seconds per minute. If the engine does not start after several attempts, push choke control in, wait a few minutes and try again. If engine still does not start, pull the choke control out and retry.

WARM WEATHER STARTING (50° F and above)

7. When engine starts, slowly push choke control in until the engine begins to run smoothly. If the engine starts to run roughly, pull the choke control out slightly for a few seconds and then continue to push the control in slowly.
- The attachments and ground drive can now be used. If the engine does not accept the load, restart the engine and allow it to warm up for one minute using the choke as described above.

COLD WEATHER STARTING (50° F and below)

7. When engine starts, slowly push choke control in until the engine begins to run smoothly. Continue to push the choke control in small steps allowing the engine to accept small changes in speed and load, until the choke control is fully in.

- If the engine starts to run roughly, pull the choke control out slightly for a few seconds and then continue to push the control in slowly. This may require an engine warm-up period from several seconds to several minutes, depending on the temperature.

AUTOMATIC TRANSMISSION WARM UP
Before driving the unit in cold weather, the transmission should be warmed up as follows:

1. Be sure the tractor is on level ground.
 2. Release the parking brake and let the brake slowly return to operating position.
 3. Allow one minute for transmission to warm up. This can be done during the engine warm up period.
- The attachments can be used during the engine warm-up period after the transmission has been warmed up and may require the choke control be pulled out slightly.

NOTE: If at a high altitude (above 3000 feet) or in cold temperatures (below 32 F) the carburetor fuel mixture may need to be adjusted for best engine performance. (See “TO ADJUST CARBURETOR” in the Service and Adjustments section of this manual).

PURGE TRANSMISSION

CAUTION: Never engage or disengage freewheel lever while the engine is running. To ensure proper operation and performance, it is recommended that the transmission be purged before operating tractor for the first time. This procedure will remove any trapped air inside the transmission which may have developed during shipping of your tractor.

IMPORTANT: Should your transmission require removal for service or replacement, it should be purged after reinstallation before operating the tractor.

1. Place tractor safely on level surface with engine off and parking brake set.
2. Disengage transmission by placing freewheel control in disengaged position (See “TO TRANSPORT” in this section of manual).
3. Sitting in the tractor seat, start engine. After the engine is running, move throttle control to slow position. Disengage parking brake.
4. Depress forward drive pedal to full forward position and hold for five (5) seconds and release pedal. Depress reverse drive pedal to full reverse position and hold for five (5) seconds and release pedal. Repeat this procedure three (3) times.

NOTE: During this step there will be no movement of drive wheels. The air is being removed from hydraulic drive system.

5. Shut off engine and set parking brake.
6. Engage transmission by placing freewheel control in “transmission engaged” position (See “TO TRANSPORT” in this section of manual).
7. Sitting in the tractor seat, start engine. After the engine is running, move throttle control to half (1/2) speed. Disengage parking brake.
8. Drive tractor forward for approximately five feet then backwards for five feet. Repeat this driving procedure three times. Your transmission is now purged and ready for normal operation.

MOWING TIPS

- Mower should be properly leveled for best mowing performance. See “TO LEVEL MOWER HOUSING” in the Service and Adjustments section of this manual.
- The left hand side of mower should be used for trimming.
- Drive so that clippings are discharged onto the area that has already been cut. Have the cut area to the right of the tractor. This will result in a more even distribution of clippings and more uniform cutting.
- When mowing large areas, start by turning to the right so that clippings will discharge away from shrubs, fences, driveways, etc. After one or two rounds, mow in the opposite direction making left hand turns until finished.

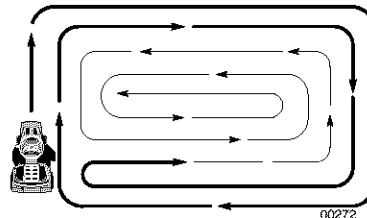

- If grass is extremely tall, it should be mowed twice to reduce load and possible fire hazard from dried clippings. Make first cut relatively high; the second to the desired height.
- Do not mow grass when it is wet. Wet grass will plug mower and leave undesirable clumps. Allow grass to dry before mowing.
- **Always operate engine at full throttle when mowing** to assure better mowing performance and proper discharge of material. Regulate ground speed by selecting a low enough gear to give the mower cutting performance as well as the quality of cut desired.
- When operating attachments, select a ground speed that will suit the terrain and give best performance of the attachment being used.

MAINTENANCE

| MAINTENANCE SCHEDULE | | SERVICE DATES | | | | | | |
|---|---|-----------------|---------------|------------------|------------------|-----------------|--------------|----------------|
| FILL IN DATES AS YOU COMPLETE REGULAR SERVICE | | BEFORE EACH USE | EVERY 8 HOURS | EVERY 25 HOURS | EVERY 50 HOURS | EVERY 100 HOURS | EVERY SEASON | BEFORE STORAGE |
| T R A C T O R | Check Brake Operation | ✓ | ✓ | | | | | |
| | Check Tire Pressure | ✓ | ✓ | | | | | |
| | Check Operator Presence and Interlock Systems | ✓ | | | | | | |
| | Check for Loose Fasteners | ✓ | | | ✓ ₅ | | ✓ | |
| | Sharpen/Replace Mower Blades | | | ✓ ₃ | | | | |
| | Lubrication Chart | | | ✓ | | | ✓ | |
| | Check Battery Level | | | ✓ ₄ | | | | |
| | Clean Battery and Terminals | | | ✓ | | | ✓ | |
| | Check Transaxle Cooling | | | ✓ | | | | |
| | Check V-Belts | | | | ✓ | | | |
| E N G I N E | Check Engine Oil Level | ✓ | ✓ | | | | | |
| | Change Engine Oil (with oil filter) | | | ✓ _{1,2} | | | ✓ | |
| | Change Engine Oil (without oil filter) | | | ✓ _{1,2} | | | ✓ | |
| | Clean Air Filter | | | ✓ ₂ | | | | |
| | Clean Air Screen | | | ✓ ₂ | | | | |
| | Inspect Muffler/Spark Arrester | | | ✓ | | | | |
| | Replace Oil Filter (If equipped) | | | | ✓ _{1,2} | | | |
| | Clean Engine Cooling Fans | | | | ✓ ₂ | | | |
| | Replace Spark Plug | | | | ✓ | ✓ | | |
| | Replace Air Filter Paper Cartridge | | | | ✓ ₂ | | | |
| Replace Fuel Filter | | | | | ✓ | | | |

1 - Change more often when operating under a heavy load or in high ambient temperatures.
2 - Service more often when operating in dirty or dusty conditions.

3 - Replace blades more often when mowing in sandy soil.
4 - Not required if equipped with maintenance-free battery.
5 - Tighten front axle pivot bolt to 35 ft.-lbs. maximum. Do not overtighten.

GENERAL RECOMMENDATIONS

The warranty on this tractor does not cover items that have been subjected to operator abuse or negligence. To receive full value from the warranty, operator must maintain tractor as instructed in this manual.

Some adjustments will need to be made periodically to properly maintain your tractor.

At least once a season, check to see if you should make any of the adjustments described in the Service and Adjustments section of this manual.

- At least once a year you should replace the spark plug, clean or replace air filter, and check blades and belts for wear. A new spark plug and clean air filter assure proper air-fuel mixture and help your engine run better and last longer.

BEFORE EACH USE

- Check engine oil level.
- Check brake operation.
- Check tire pressure.
- Check operator presence and interlock systems for proper operation.
- Check for loose fasteners.

LUBRICATION CHART

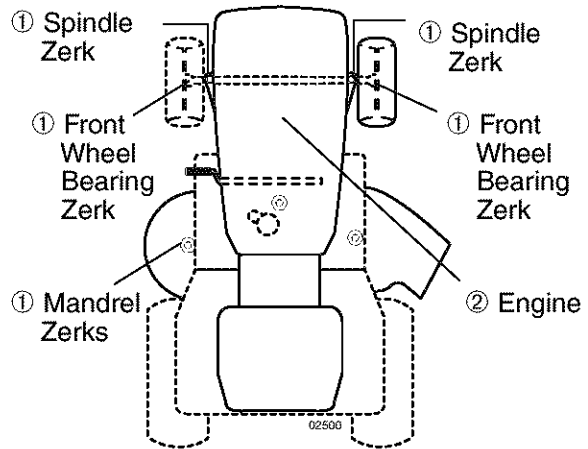

- ① General Purpose Grease
- ② Refer to Maintenance "ENGINE" Section

IMPORTANT: Do not oil or grease the pivot points which have special nylon bearings. Viscous lubricants will attract dust and dirt that will shorten the life of the self-lubricating bearings. If you feel they must be lubricated, use only a dry, powdered graphite type lubricant sparingly.

TRACTOR

Always observe safety rules when performing any maintenance.

BRAKE OPERATION

If tractor requires more than six (6) feet stopping distance at high speed in highest gear, then brake must be adjusted. (See "TO ADJUST BRAKE" in the Service and Adjustments section of this manual).

TIRES

- Maintain proper air pressure in all tires (See "PRODUCT SPECIFICATIONS" section of this manual).
- Keep tires free of gasoline, oil, or insect control chemicals which can harm rubber.
- Avoid stumps, stones, deep ruts, sharp objects and other hazards that may cause tire damage.

NOTE: To seal tire punctures and prevent flat tires due to slow leaks, tire sealant may be purchased from your local parts dealer. Tire sealant also prevents tire dry rot and corrosion.

OPERATOR PRESENCE SYSTEM

Be sure that operator presence and interlock systems are working properly. If your tractor does not function as described below, repair the problem immediately.

- The engine should not start unless the brake pedal is fully depressed and attachment clutch control is in the disengaged position.
- When the engine is running, any attempt by the operator to leave the seat without first setting the parking brake should shut off the engine.
- When the engine is running and the attachment clutch is engaged, any attempt by the operator to leave the seat should shut off the engine.
- The attachment clutch should never operate unless the operator is in the seat.

BLADE CARE

For best results mower blades must be kept sharp. Replace bent or damaged blades.

BLADE REMOVAL

1. Raise mower to highest position to allow access to blades.

NOTE: Protect your hands with gloves and/or wrap blade with heavy cloth.

2. Remove blade bolt by turning counter-clockwise.
3. Install new or resharpened blade with stamped "THIS SIDE UP" facing deck and mandrel assembly.

IMPORTANT: To ensure proper assembly, center hole in blade must align with star on mandrel assembly.

4. Install and tighten blade bolt securely (45-55 Ft. Lbs. torque).

IMPORTANT: Special blade bolt is heat treated.

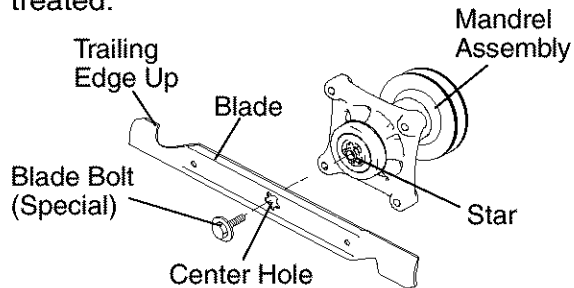

TO SHARPEN BLADE

NOTE: We do not recommend sharpening blade - but if you do, be sure the blade is balanced.

Care should be taken to keep the blade balanced. An unbalanced blade will cause excessive vibration and eventual damage to mower and engine.

- The blade can be sharpened with a file or on a grinding wheel. Do not attempt to sharpen while on the mower.
- To check blade balance, you will need a 5/8" diameter steel bolt, pin, or a cone balancer. (When using a cone balancer, follow the instructions supplied with balancer.)

NOTE: Do not use a nail for balancing blade. The lobes of the center hole may appear to be centered, but are not.

- Slide blade on to an unthreaded portion of the steel bolt or pin and hold the bolt or pin parallel with the ground. If blade is balanced, it should remain in a horizontal position. If either end of the blade moves downward, sharpen the heavy end until the blade is balanced.

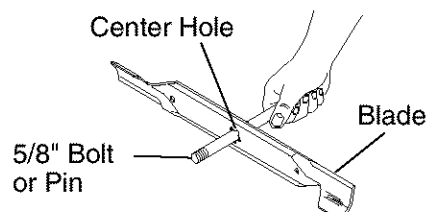

BATTERY

Your tractor has a battery charging system which is sufficient for normal use. However, periodic charging of the battery with an automotive charger will extend its life.

- Keep battery and terminals clean.
- Keep battery bolts tight.
- Keep small vent holes open.
- Recharge at 6-10 amperes for 1 hour.

NOTE: The original equipment battery on your tractor is maintenance free. Do not attempt to open or remove caps or covers. Adding or checking level of electrolyte is not necessary.

TO CLEAN BATTERY AND TERMINALS

Corrosion and dirt on the battery and terminals can cause the battery to "leak" power.

1. Remove terminal guard.
2. Disconnect BLACK battery cable first then RED battery cable and remove battery from tractor.
3. Rinse the battery with plain water and dry.
4. Clean terminals and battery cable ends with wire brush until bright.
5. Coat terminals with grease or petroleum jelly.
6. Reinstall battery (See "REPLACING BATTERY" in the SERVICE AND ADJUSTMENTS section of this manual).

TRANSAXLE COOLING

The transmission fan and cooling fins should be kept clean to assure proper cooling.

Do not attempt to clean fan or transmission while engine is running or while the transmission is hot. To prevent possible damage to seals, do not use high pressure water or steam to clean transaxle.

- Inspect cooling fan to be sure fan blades are intact and clean.
- Inspect cooling fins for dirt, grass clippings and other materials. To prevent damage to seals, do not use compressed air or high pressure sprayer to clean cooling fins.

TRANSAXLE PUMP FLUID

The transaxle was sealed at the factory and fluid maintenance is not required for the life of the transaxle. Should the transaxle ever leak or require servicing, contact a sears or other qualified service center.

V-BELTS

Check V-belts for deterioration and wear after 100 hours of operation and replace if necessary. The belts are not adjustable. Replace belts if they begin to slip from wear.

ENGINE

LUBRICATION

Only use high quality detergent oil rated with API service classification SF-SJ. Select the oil's SAE viscosity grade according to your expected operating temperature.

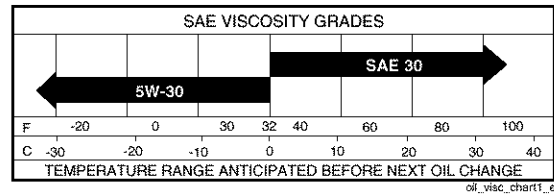

NOTE: Although multi-viscosity oils (5W30, 10W30 etc.) improve starting in cold weather, they will result in increased oil consumption when used above 32°F. Check your engine oil level more frequently to avoid possible engine damage from running low on oil.

Change the oil after every 50 hours of operation or at least once a year if the tractor is not used for 50 hours in one year. Check the crankcase oil level before starting the engine and after each eight (8) hours of operation. Tighten oil fill cap/dipstick securely each time you check the oil level.

TO CHANGE ENGINE OIL

Determine temperature range expected before oil change. All oil must meet API service classification SF-SJ.

- Be sure tractor is on level surface.
 - Oil will drain more freely when warm.
 - Catch oil in a suitable container.
1. Remove oil fill cap/dipstick. Be careful not to allow dirt to enter the engine when changing oil.
 2. Remove yellow cap from end of drain valve and install the drain tube onto the fitting.

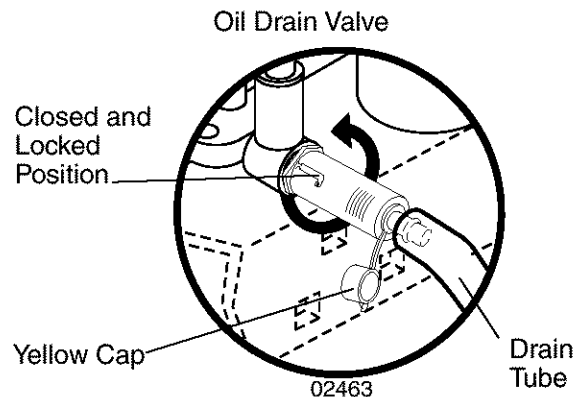

3. Unlock drain valve by pushing inward slightly and turning counterclockwise.
4. To open, pull out on the drain valve.
5. After oil has drained completely, close and lock the drain valve by pushing inward and turning clockwise until the pin is in the locked position as shown.
6. Remove the drain tube and replace the cap onto the end of the drain valve.

7. Refill engine with oil through oil fill dipstick tube. Pour slowly. Do not overfill. For approximate capacity see "PRODUCT SPECIFICATIONS" section of this manual.
8. Use gauge on oil fill cap/dipstick for checking level. For accurate reading, tighten dipstick cap securely onto the tube before removing dipstick. Keep oil at "FULL" line on dipstick. Tighten cap onto the tube securely when finished.

ENGINE OIL FILTER

Replace the engine oil filter every season or every other oil change if the tractor is used more than 100 hours in one year.

AIR FILTER

Your engine will not run properly using a dirty air filter. Clean the foam pre-cleaner after every 25 hours of operation or every season. Service paper cartridge every 100 hours of operation or every season, whichever occurs first.

Service air cleaner more often under dusty conditions.

1. Remove knobs and cover.

TO SERVICE PRE-CLEANER

2. Wash it in liquid detergent and water.
3. Squeeze it dry in a clean cloth.
4. Saturate it in engine oil. Wrap it in clean, absorbent cloth and squeeze to remove excess oil.

NOTE: If very dirty or damaged, replace pre-cleaner.

TO SERVICE CARTRIDGE

1. Clean cartridge by tapping gently on flat surface. If very dirty or damaged, replace cartridge.
2. Reinstall precleaner cartridge, cover and secure with knobs.

IMPORTANT: Petroleum solvents, such as kerosene, are not to be used to clean the cartridge. They may cause deterioration of the cartridge. Do not oil cartridge. Do not use pressurized air to clean or dry cartridge.

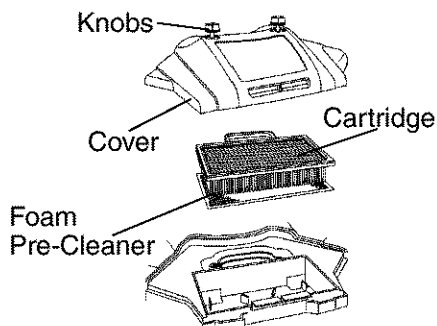

CLEAN AIR SCREEN

Air screen must be kept free of dirt and chaff to prevent engine damage from overheating. Clean with a wire brush or compressed air to remove dirt and stubborn dried gum fibers.

CLEAN AIR INTAKE/COOLING AREAS

To insure proper cooling, make sure the grass screen, cooling fins, and other external surfaces of the engine are kept clean at all times.

Every 100 hours of operation (more often under extremely dusty, dirty conditions), remove the blower housing and other cooling shrouds. Clean the cooling fins and external surfaces as necessary. Make sure the cooling shrouds are reinstalled.

NOTE: Operating the engine with a blocked grass screen, dirty or plugged cooling fins, and/or cooling shrouds removed will cause engine damage due to overheating.

MUFFLER

Inspect and replace corroded muffler and spark arrester (if equipped) as it could create a fire hazard and/or damage.

SPARK PLUG(S)

Replace spark plug(s) at the beginning of each mowing season or after every 100 hours of operation, whichever occurs first. Spark plug type and gap setting are shown in "PRODUCT SPECIFICATIONS" section of this manual.

IN-LINE FUEL FILTER

The fuel filter should be replaced once each season. If fuel filter becomes clogged, obstructing fuel flow to carburetor, replacement is required.

1. With engine cool, remove filter and plug fuel line sections.
2. Place new fuel filter in position in fuel line with arrow pointing towards carburetor.
3. Be sure there are no fuel line leaks and clamps are properly positioned.
4. Immediately wipe up any spilled gasoline.

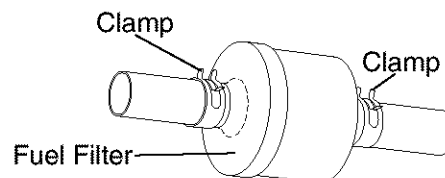

CLEANING

- Clean engine, battery, seat, finish, etc. of all foreign matter.
- Keep finished surfaces and wheels free of all gasoline, oil, etc.
- Protect painted surfaces with automotive type wax.

We do not recommend using a garden hose or pressure washer to clean your tractor unless the engine and transmission are covered to keep water out. Water in engine or transmission will shorten the useful life of your tractor. Use compressed air or a leaf blower to remove grass, leaves and trash from tractor and mower.

SERVICE AND ADJUSTMENTS



WARNING: TO AVOID SERIOUS INJURY, BEFORE PERFORMING ANY SERVICE OR ADJUSTMENTS:

1. Depress brake pedal fully and set parking brake.
2. Place attachment clutch in "DISENGAGED" position.
3. Turn ignition key "STOP" and remove key.
4. Make sure the blades and all moving parts have completely stopped.
5. Disconnect spark plug wire from spark plug and place wire where it cannot come in contact with plug.

TO REMOVE MOWER

1. Place attachment clutch in "DISENGAGED" position.
2. If equipped, turn height adjustment knob to lowest setting.
3. Lower mower to its lowest position.
4. Disengage belt tension rod from lock bracket.

CAUTION: Rod is spring loaded. Have a tight grip on rod and release slowly.

5. Remove retainer spring holding anti-swaybar to chassis bracket and disengage anti-swaybar from bracket.
6. Remove four retainer springs from front plate assembly and remove plate.
7. Remove retainer springs from suspension arms at deck and disengage arms from deck.

8. Raise attachment lift to its highest position.
9. Slide mower forward and remove belt from electric clutch pulley.
10. Slide mower out from under right side of tractor.

TO INSTALL MOWER

Be sure tractor is on level surface and mower suspension arms are raised with attachment lift control. Engage parking brake.

1. Swing anti-swaybar to left side of mower deck.
2. Slide mower under tractor with deflector shield to right side of tractor.

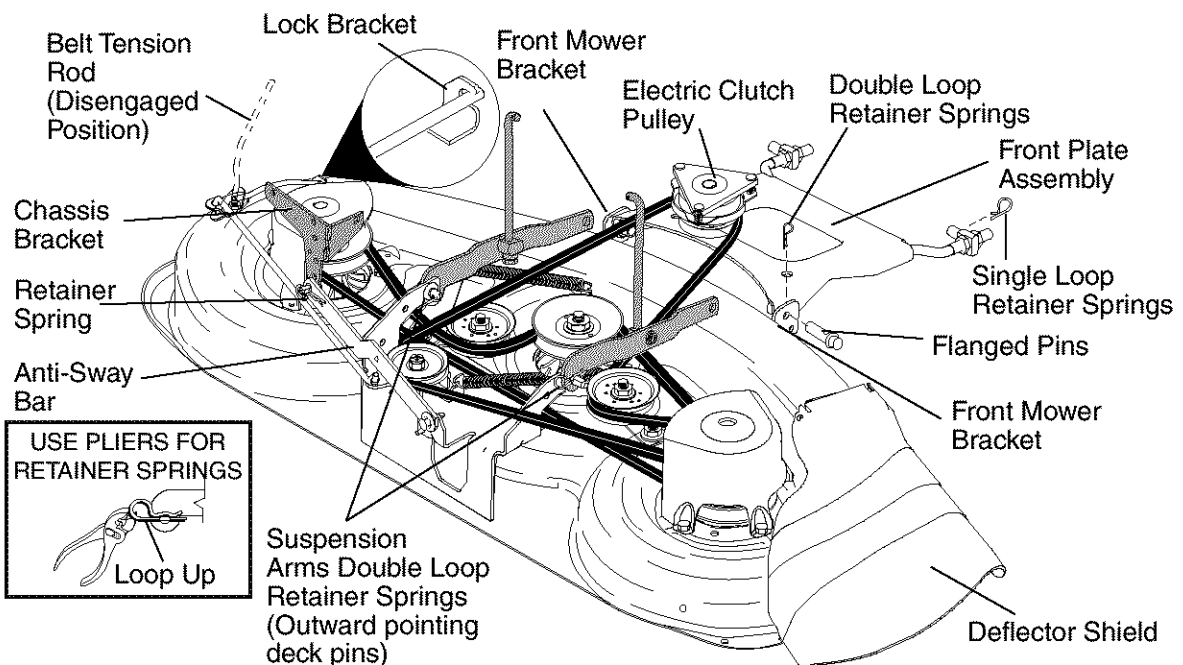

IMPORTANT: Check belt for proper routing in all mower pulley grooves.

3. If equipped, turn height adjustment knob counterclockwise until it stops.
4. Lower mower linkage with attachment lift control.
5. Be sure belt tension rod is in disengaged position.
6. Install belt into electric clutch pulley groove.
7. Place the suspension arms on outward pointing deck pins. Retain with double loop retainer spring with loops up as shown.
8. Install front plate assembly to tractor suspension brackets and retain with single loop retainer springs as shown.
9. Position front plate assembly between front mower brackets. Raise deck and plate assembly to align holes and insert flanged pins. Secure pins with double loop retainer springs between the plate assembly and mower brackets.

NOTE: To assist in locating hole in flanged pin, the hole in pin is inline with notch on head of pin. If necessary, move mower side-to-side to give space between plate and mower brackets.

IMPORTANT: Check belt for proper routing in all mower pulley grooves.

10. Engage belt tension rod by pushing rod into locking bracket.

CAUTION: Belt tension rod is spring loaded. Have a tight grip on rod and engage slowly.

11. Connect anti-sway bar to chassis bracket under left footrest and retain with double loop retainer spring.
12. If equipped, turn height adjustment knob clockwise to remove slack from mower suspension.
13. Raise deck to highest position.

TO LEVEL MOWER HOUSING

Adjust the mower while tractor is parked on level ground such as a carport or garage. Make sure tires are properly inflated (See "PRODUCT SPECIFICATIONS" section of this manual). If tires are over or underinflated, you will not properly adjust your mower.

SIDE-TO-SIDE ADJUSTMENT WITH BUBBLE LEVEL

NOTE: If necessary, check side-to-side surface below tractor for levelness with a long board and the bubble level.

- Using the lift lever, place mower in position where no part of the mower, including gauge wheels, is touching the ground.
- From left side of tractor, find the level decal on top of mower and place bubble level on decal as indicated.
- Mower is level side-to-side when bubble is between the two lines in the bubble level.
- If adjustment is necessary, under left hand footrest, turn lift link adjustment nut (above yellow cap) in appropriate direction to bring bubble between the lines in the bubble level.
- Remove bubble level from mower and store in a safe place.

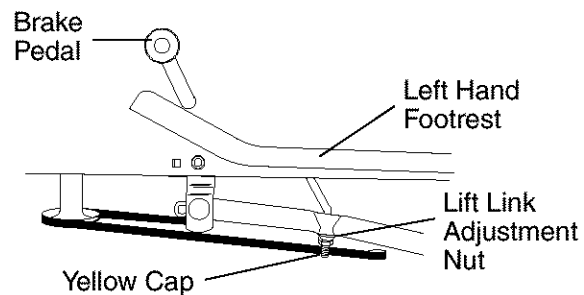
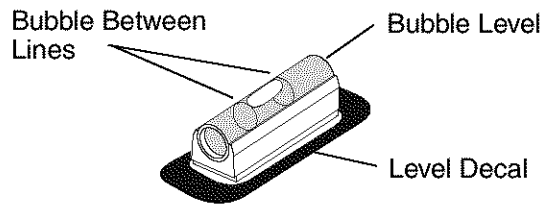

ALTERNATE SIDE-TO-SIDE ADJUSTMENT METHOD

- Raise mower to its highest position.
- Measure height from bottom edge of mower to ground level at front corners of mower. Distance "A" on both sides of mower should be the same.
- If adjustment is necessary, make adjustment on one side of mower only.
- To raise one side of mower, tighten lift link adjustment nut on that side.
- To lower one side of mower, loosen lift link adjustment nut on that side.

NOTE: Each full turn of adjustment nut will change mower height about 3/16".

- Recheck measurements after adjusting.

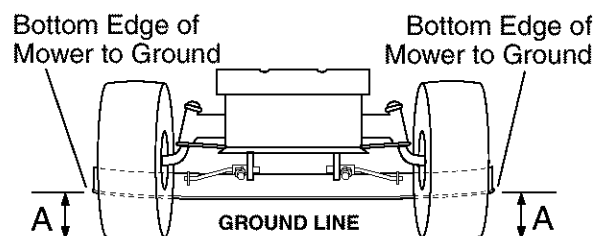

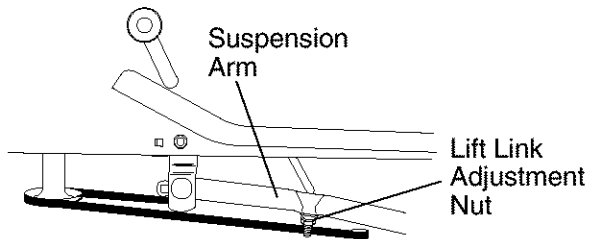

FRONT-TO-BACK ADJUSTMENT

IMPORTANT: Deck must be level side-to-side. If the following front-to-back adjustment is necessary, be sure to adjust both front links equally so mower will stay level side-to-side.

To obtain the best cutting results, the mower blades should be adjusted so the front tip is approximately 1/8" to 1/2" lower than the rear tip when the mower is in its highest position.

CAUTION: Blades are sharp. Protect your hands with gloves and/or wrap blade with heavy cloth.

Check adjustment on right side of tractor. Position any blade so the tip is pointing straight forward. Measure distance "B" at front and rear tip of blade

- Before making any necessary adjustments, check that both front plate links are equal in length.
- If links are not equal in length, adjust one link to same length as other link.
- To lower front of blade, loosen nut "C" on both front links an equal number of turns.

NOTE: Each full turn of nut "C" will change dim. "B" by approximately 3/16".

- When distance "B" is 1/8" to 1/2" lower at front than rear, tighten nut "D" against trunnion on both front links.
- To raise front of mower, loosen nut "F" from trunnion on both front links. Tighten nut "E" on both front links an equal number of turns. The two front links must remain equal in length.
- When distance "D" is 1/8" to 1/2" lower at front than rear, tighten nut "F" against trunnion on both front links.
- Recheck side-to-side adjustment.

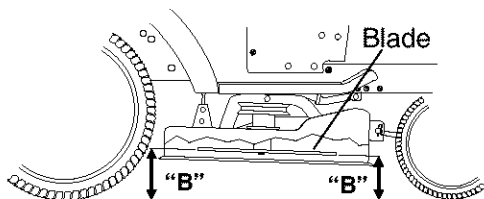

BOTH FRONT PLATE LINKS MUST BE EQUAL IN LENGTH

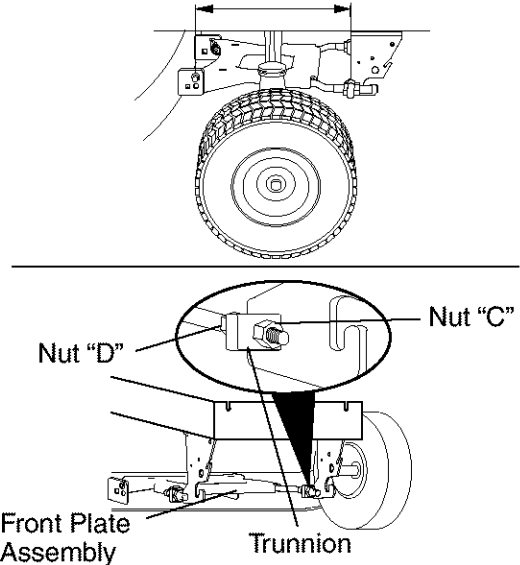

TO REPLACE MOWER DRIVE BELT

MOWER DRIVE BELT REMOVAL

1. Park tractor on a level surface. Engage parking brake.
2. Lower mower to its lowest position.
3. Disengage belt tension rod from lock bracket.

CAUTION: Rod is spring loaded. Have a firm grip on rod and release slowly.

4. Remove screws from R.H. mandrel cover and remove cover.
5. Remove any dirt or grass clippings which may have accumulated around mandrels and entire upper deck surface.
6. Disconnect R.H. suspension arm from rear deck bracket by removing retainer spring.
7. Carefully roll belt over the top of R.H. mandrel pulley.
8. Remove belt from electric clutch pulley.
9. Remove belt from idler pulleys.
10. Check primary idler arm and two idlers to see that they rotate freely.
11. Be sure spring is securely hooked to primary idler arm and spring arm.

MOWER DRIVE BELT INSTALLATION

12. Install belt in both idlers.
13. Install new belt onto electric clutch pulley.
14. Carefully roll belt into upper groove of R.H. mandrel pulley.
15. Carefully check belt routing making sure belt is in the grooves correctly.
16. Reconnect R.H. suspension arm to rear deck bracket with retainer spring.
17. Reassemble R.H. mandrel cover.

- Engage belt tension rod by pushing rod into locking bracket.

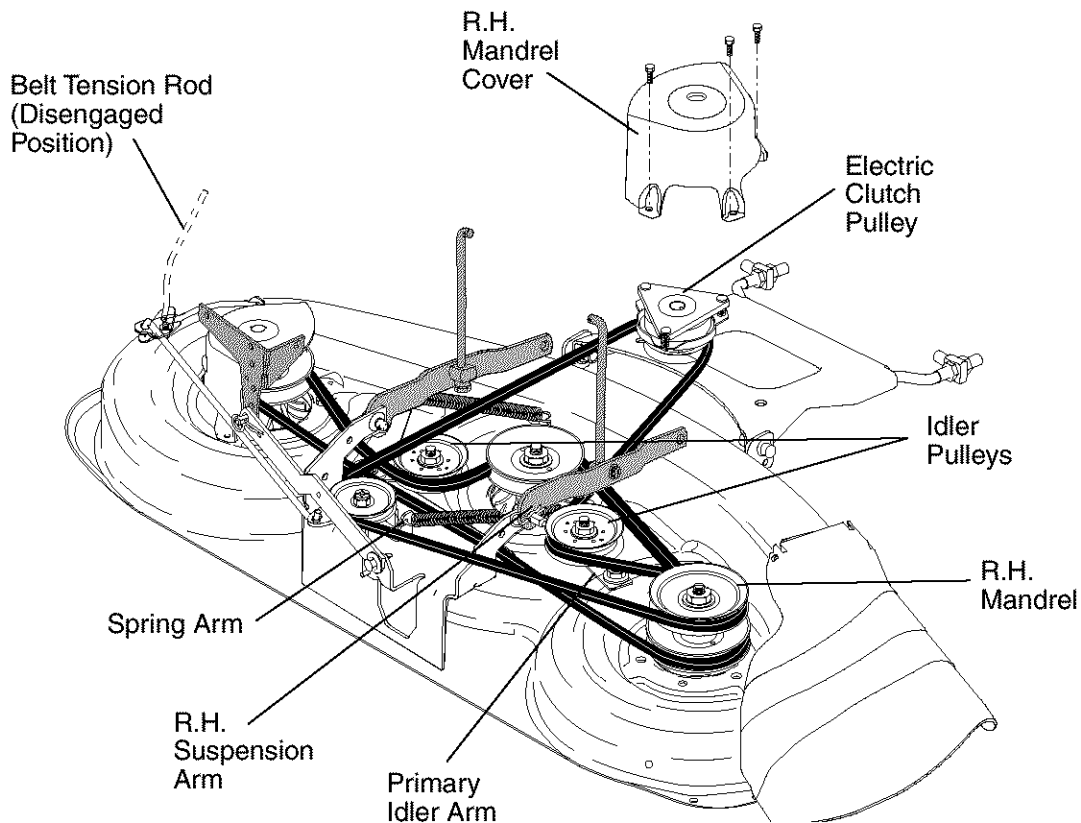

TO REPLACE MOWER BLADE (SECONDARY) DRIVE BELT

Park the tractor on level surface. Engage parking brake.

- Remove mower (See "TO REMOVE MOWER" in this section of manual).
- Remove screws from R.H. and L.H. mandrel covers and remove covers.

REMOVE MOWER DRIVE BELT
(Refer to "TO REMOVE MOWER DRIVE BELT" illustration in this section of manual).

- Carefully roll belt over the top of R.H. mandrel pulley.
- Remove belt from idler pulleys.
- Check primary idler arm and two idlers to see that they rotate freely.
- Be sure spring is securely hooked to primary idler arm and spring arm.

REMOVE MOWER BLADE (SECONDARY) DRIVE BELT

- Carefully roll belt off L.H. mandrel pulley.
- Remove belt from center mandrel pulley, idler pulley, and R.H. mandrel pulley.

- Remove any dirt or grass which may have accumulated around mandrels and entire upper deck surface.
- Check secondary idler arm and idler pulley to see that they rotate freely.
- Be sure spring is hooked in secondary idler arm and secondary spring arm.

INSTALL NEW MOWER BLADE (SECONDARY) DRIVE BELT

- Install new belt in lower groove of R.H. mandrel pulley, idler pulley, and center mandrel pulley as shown.
- Carefully roll belt over L.H. mandrel pulley. Make sure belt is in all grooves properly.

REINSTALL MOWER DRIVE BELT
(Refer to "TO REMOVE MOWER DRIVE BELT" illustration in this section of manual).

- Install belt into upper groove of R.H. mandrel pulley and around both idlers. Pull belt to front of mower to remove slack.
- Reinstall mandrel covers and securely tighten all screws.
- Carefully check belt routing making sure belt is in all grooves correctly.

17. Reinstall mower to tractor (See "TO INSTALL MOWER" in this section of manual).

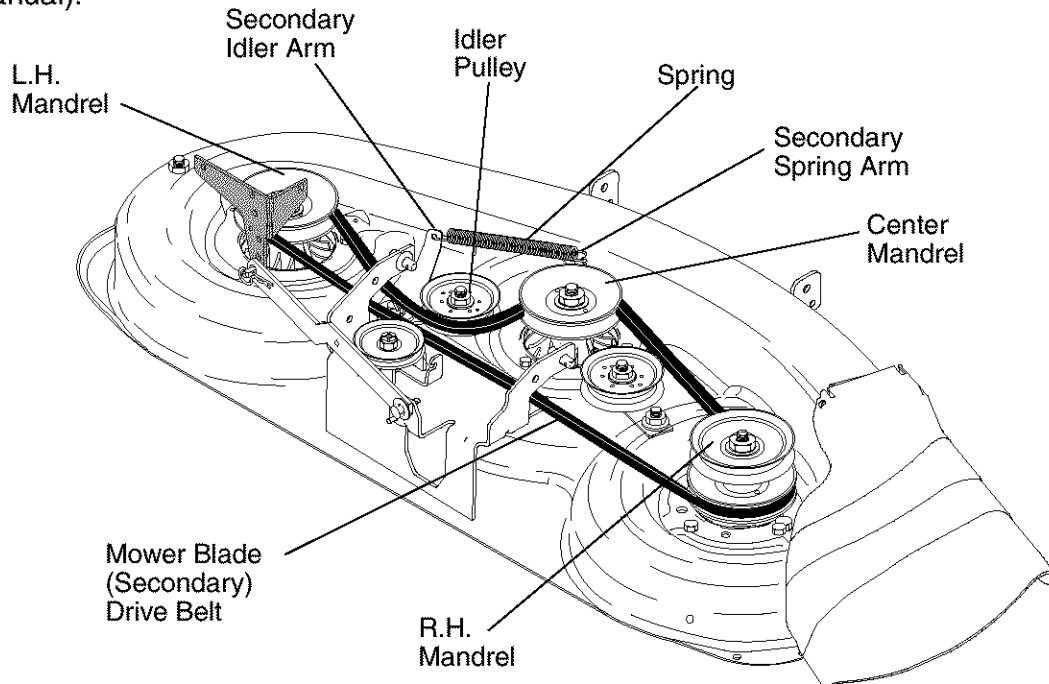

TO CHECK AND ADJUST BRAKE

Your tractor is equipped with an adjustable brake system which is mounted on the right side of the transaxle.

If tractor requires more than five (5) feet to stop at highest speed in highest gear on a level, dry concrete or paved surface, then brake must be checked and adjusted.

TO CHECK BRAKE

1. Park tractor on a level, dry concrete or paved surface, depress brake pedal all the way down and engage parking brake.
2. Disengage transmission by placing freewheel control in "transmission disengaged" position. Pull freewheel control out and into the slot and release so it is held in the disengaged position.

The rear wheels must lock and skid when you try to manually push the tractor forward. If the rear wheels rotate, the brake needs to be adjusted or the pads need to be replaced.

TO ADJUST BRAKE

1. Depress brake pedal all the way down and engage parking brake.
2. Measure distance between brake operating arm and nut "A" on brake rod.
3. If distance is other than 1-3/4", loosen jam nut and turn nut "A" until distance becomes 1-3/4". Retighten jam nut against nut "A".

4. Engage transmission by placing freewheel control in "transmission engaged" position.
5. Road test tractor for proper stopping distance as stated above. Readjust if necessary. If stopping distance is still greater than five (5) feet in highest gear, further maintenance is necessary. Replace brake pads or contact a Sears or other qualified service center.

With parking brake "Engaged"

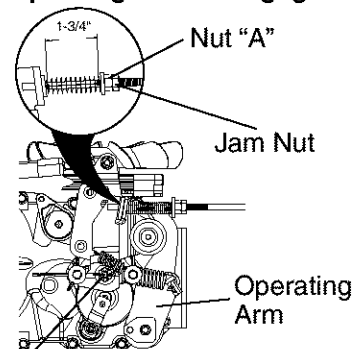

Do not touch this nut. If further brake adjustment is necessary contact a Sears or other qualified service center.

TO REPLACE MOTION DRIVE BELT

Park the tractor on level surface. Engage parking brake. For assistance, there is a belt installation guide decal on bottom side of left footrest.

BELT REMOVAL -

1. Remove mower (See "TO REMOVE MOWER" in this section of manual).
- NOTE:** Observe entire motion drive belt and position of all belt guides and keepers.
2. Disconnect clutch wire harness.
3. Remove clutch locator.
4. Remove belt from stationary idler and clutching idler.
5. Remove belt downward from engine pulley and around electric clutch.
6. Pull belt slack toward rear of tractor. Carefully remove belt upwards from transmission input pulley and over cooling fan blades.
7. Remove belt from center span keeper and pull belt away from tractor.

BELT INSTALLATION -

1. Carefully work new belt down around transmission cooling fan and onto the input pulley.
2. Slide belt into the center span keeper.
3. Pull belt toward front of tractor and roll belt around electric clutch and onto engine pulley.
4. Install belt through stationary idler and clutching idler.
5. Reinstall clutch locator and tighten nut securely.
6. Reconnect clutch harness.
7. Make sure belt is in all pulley grooves and inside all belt guides and keepers.
8. Install mower (See "TO INSTALL MOWER" in this section of manual).

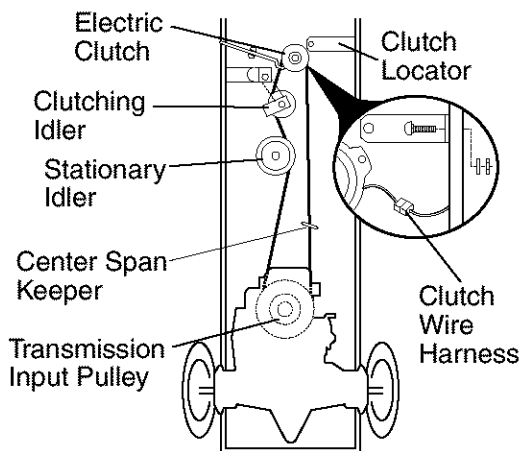

TRANSMISSION REMOVAL/ REPLACEMENT

Should your transmission require removal for service or replacement, it should be purged after reinstallation and before operating the tractor. See "PURGE TRANSMISSION" in the Operation section of this manual.

TO ADJUST STEERING WHEEL ALIGNMENT

If steering wheel crossbars are not horizontal (left to right) when wheels are positioned straight forward, remove steering wheel and reassemble with crossbars horizontal. Tighten securely.

FRONT WHEEL TOE-IN/CAMBER

The front wheel toe-in and camber are not adjustable on your tractor. If damage has occurred to affect the front wheel toe-in or camber, contact your nearest Sears or other qualified service center.

TO REMOVE WHEEL FOR REPAIRS

1. Block up axle securely.
2. Remove axle cover, retaining ring and washers to allow wheel removal (rear wheels have a square key - Do not lose).

3. Repair tire and reassemble.

NOTE: On rear wheels only: align grooves in rear wheel hub and axle. Insert square key.

4. Replace washers and snap retaining ring securely in axle groove.
5. Replace axle cover.

NOTE: To seal tire punctures and prevent flat tires due to slow leaks, purchase and use tire sealant from Sears. Tire sealant also prevents tire dry rot and corrosion.

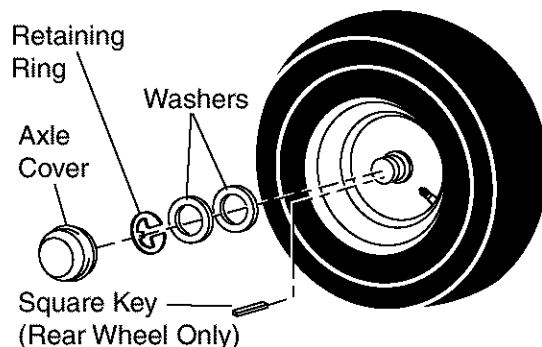

TO START ENGINE WITH A WEAK BATTERY

WARNING: Lead-acid batteries generate explosive gases. Keep sparks, flame and smoking materials away from batteries. Always wear eye protection when around batteries.

If your battery is too weak to start the engine, it should be recharged. (See "BATTERY" in the Maintenance section of this manual).

If "jumper cables" are used for emergency starting, follow this procedure:

IMPORTANT: Your tractor is equipped with a 12 volt system. The other vehicle must also be a 12 volt system. Do not use your tractor battery to start other vehicles.

TO ATTACH JUMPER CABLES -

1. Connect one end of the RED cable to the POSITIVE (+) terminal of each battery(A-B), taking care not to short against tractor chassis.
2. Connect one end of the BLACK cable to the NEGATIVE (-) terminal (C) of fully charged battery.
3. Connect the other end of the BLACK cable (D) to good chassis ground, away from fuel tank and battery.

TO REMOVE CABLES, REVERSE ORDER -

1. BLACK cable first from chassis and then from the fully charged battery.
2. RED cable last from both batteries.

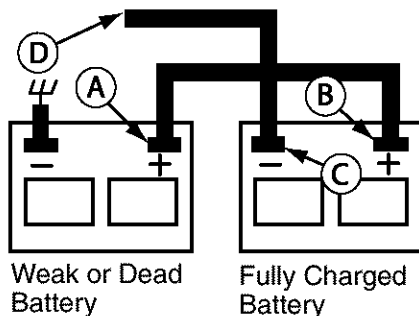

REPLACING BATTERY

⚠WARNING: Do not short battery terminals by allowing a wrench or any other object to contact both terminals at the same time. Before connecting battery, remove metal bracelets, wristwatch bands, rings, etc.

Positive terminal must be connected first to prevent sparking from accidental grounding.

1. Lift hood to raised position.
2. Remove terminal guard.
3. Disconnect BLACK battery cable then RED battery cable and carefully remove battery from tractor.
4. Install new battery with terminals in same position as old battery.
5. Reinstall terminal guard.

6. First connect RED battery cable to positive (+) battery terminal with hex bolt and keps nut as shown. Tighten securely.
7. Connect BLACK grounding cable to negative (-) battery terminal with remaining hex bolt and keps nut. Tighten securely
8. Close terminal access doors.
9. Close hood.

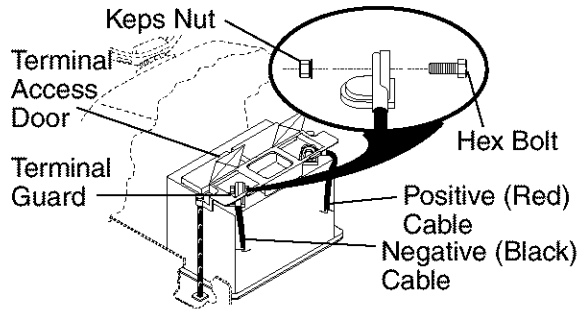

TO REPLACE HEADLIGHT BULB

1. Raise hood.
2. Pull bulb holder out of the hole in the backside of the grill.
3. Replace bulb in holder and push bulb holder securely back into the hole in the backside of the grill.
4. Close hood.

INTERLOCKS AND RELAYS

Loose or damaged wiring may cause your tractor to run poorly, stop running, or prevent it from starting.

- Check wiring. See electrical wiring diagram in the Repair Parts section.

TO REPLACE FUSE

Replace with 20 amp automotive-type plug-in fuse. The fuse holder is located behind the dash.

TO REMOVE HOOD AND GRILL ASSEMBLY

1. Raise hood.
2. Unsnap headlight wire connector.
3. Stand in front of tractor. Grasp hood at sides, tilt toward engine and lift off of tractor.
4. When replacing hood, be sure to re-connect the headlight wire connector.

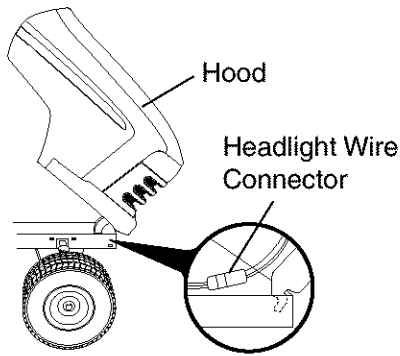

ENGINE

Maintenance, repair, or replacement of the emission control devices and systems, which are being done at the customer's expense, may be performed by any non-road engine repair establishment or individual. Warranty repairs must be performed by an authorized engine manufacturer's service outlet.

TO ADJUST THROTTLE CONTROL CABLE

The throttle control has been preset at the factory and adjustment should not be necessary. Check adjustment as described below before loosening cable. If adjustment is necessary, proceed as follows:

1. With engine not running, move throttle control lever to fast position.
2. Check that swivel is against stop. If it is not, loosen cable clamp screw and pull cable back until swivel is against stop. Tighten cable clamp screw securely.

TO ADJUST CHOKE CONTROL

The choke control has been preset at the factory and adjustment should not be necessary. Check adjustment as described below before loosening cable. If adjustment is necessary, proceed as follows:

1. With engine not running, move choke control (located on dash panel) to full choke position.
2. Loosen knob and remove cover assembly from air cleaner.
3. Choke should be closed. If it is not, loosen casing clamp screw and move choke cable until choke is completely closed. Tighten casing clamp screw securely.
4. Replace air cleaner cover assembly and tighten knob.

TO ADJUST CARBURETOR

Your carburetor is not adjustable. If your engine does not operate properly due to suspected carburetor problems, take your tractor to a Sears or other qualified service center for repair and/or adjustment.

High speed stop is factory adjusted. Do not adjust - damage may result.

IMPORTANT: Never tamper with the engine governor, which is factory set for proper engine speed. Overspeeding the engine above the factory high speed setting can be dangerous. If you think the engine-governed high speed needs adjusting, contact a Sears or other qualified service center, which has proper equipment and experience to make any necessary adjustments.

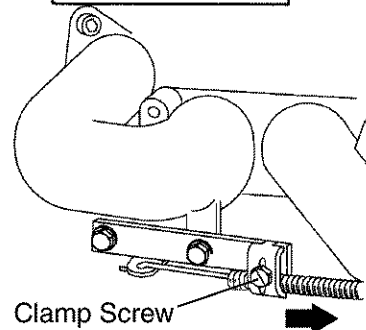
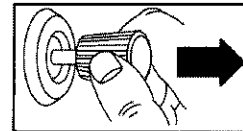
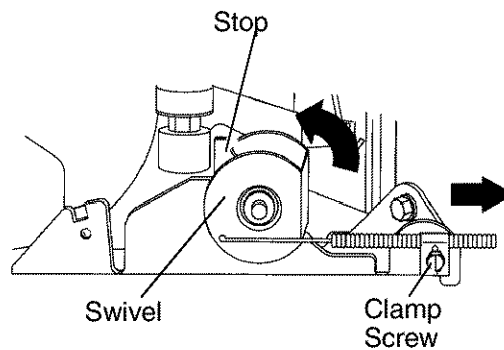

STORAGE

Immediately prepare your tractor for storage at the end of the season or if the tractor will not be used for 30 days or more.

⚠ WARNING: Never store the tractor with gasoline in the tank inside a building where fumes may reach an open flame or spark. Allow the engine to cool before storing in any enclosure.

TRACTOR

Remove mower from tractor for winter storage. When mower is to be stored for a period of time, clean it thoroughly, remove all dirt, grease, leaves, etc. Store in a clean, dry area.

1. Clean entire tractor (See "CLEANING" in the Maintenance section of this manual).
2. Inspect and replace belts, if necessary (See belt replacement instructions in the Service and Adjustments section of this manual).
3. Lubricate as shown in the Maintenance section of this manual.
4. Be sure that all nuts, bolts and screws are securely fastened. Inspect moving parts for damage, breakage and wear. Replace if necessary.
5. Touch up all rusted or chipped paint surfaces; sand lightly before painting.

BATTERY

- Fully charge the battery for storage.
- After a period of time in storage, battery may require recharging.
- To help prevent corrosion and power leakage during long periods of storage, battery cables should be disconnected and battery cleaned thoroughly (see "TO CLEAN BATTERY AND TERMINALS" in the Maintenance section of this manual).
- After cleaning, leave cables disconnected and place cables where they cannot come in contact with battery terminals.
- If battery is removed from tractor for storage, do not store battery directly on concrete or damp surfaces.

ENGINE

FUEL SYSTEM

IMPORTANT: It is important to prevent gum deposits from forming in essential fuel system parts such as carburetor, fuel hose, or tank during storage. Also, alcohol blended fuels (called gasohol or using

ethanol or methanol) can attract moisture which leads to separation and formation of acids during storage. Acidic gas can damage the fuel system of an engine while in storage.

- Empty the fuel tank by starting the engine and letting it run until the fuel lines and carburetor are empty.
- Never use engine or carburetor cleaner products in the fuel tank or permanent damage may occur.
- Use fresh fuel next season.

NOTE: Fuel stabilizer is an acceptable alternative in minimizing the formation of fuel gum deposits during storage. Add stabilizer to gasoline in fuel tank or storage container. Always follow the mix ratio found on stabilizer container. Run engine at least 10 minutes after adding stabilizer to allow the stabilizer to reach the carburetor. Do not empty the gas tank and carburetor if using fuel stabilizer.

ENGINE OIL

Drain oil (with engine warm) and replace with clean engine oil. (See "ENGINE" in the Maintenance section of this manual).

CYLINDER(S)

1. Remove spark plug(s).
2. Pour one ounce of oil through spark plug hole(s) into cylinder(s).
3. Turn ignition key to "START" position for a few seconds to distribute oil.
4. Replace with new spark plug(s).

OTHER

- Do not store gasoline from one season to another.
- Replace your gasoline can if your can starts to rust. Rust and/or dirt in your gasoline will cause problems.
- If possible, store your tractor indoors and cover it to give protection from dust and dirt.
- Cover your tractor with a suitable protective cover that does not retain moisture. Do not use plastic. Plastic cannot breathe which allows condensation to form and will cause your tractor to rust.

IMPORTANT: Never cover tractor while engine and exhaust areas are still warm.

TROUBLESHOOTING CHART:

See appropriate section in manual unless directed to Sears service center

| PROBLEM | CAUSE | CORRECTION |
|---|---|--|
| Will not start | <ol style="list-style-type: none"> 1. Out of fuel. 2. Engine not "CHOKED" properly. 3. Engine flooded. 4. Bad spark plug. 5. Dirty air filter. 6. Dirty fuel filter. 7. Water in fuel. 8. Loose or damaged wiring. 9. Carburetor out of adjustment. 10. Engine valves out of adjustment. | <ol style="list-style-type: none"> 1. Fill fuel tank. 2. See "TO START ENGINE" in Operation section. 3. Wait several minutes before attempting to start. 4. Replace spark plug. 5. Clean/replace air filter. 6. Replace fuel filter. 7. Empty fuel tank and carburetor, refill tank with fresh gasoline and replace fuel filter. 8. Check all wiring. 9. See "To Adjust Carburetor" in Service and Adjustments section. 10. Contact a Sears or other qualified service center. |
| Hard to start | <ol style="list-style-type: none"> 1. Dirty air filter. 2. Bad spark plug. 3. Weak or dead battery. 4. Dirty fuel filter. 5. Stale or dirty fuel. 6. Loose or damaged wiring. 7. Carburetor out of adjustment. 8. Engine valves out of adjustment. | <ol style="list-style-type: none"> 1. Clean/replace air filter. 2. Replace spark plug. 3. Recharge or replace battery. 4. Replace fuel filter. 5. Empty fuel tank and refill tank with fresh, clean gasoline. 6. Check all wiring. 7. See "To Adjust Carburetor" in Service and Adjustments section. 8. Contact a Sears or other qualified service center. |
| Engine will not turn over | <ol style="list-style-type: none"> 1. Brake pedal not depressed. 2. Attachment clutch is engaged. 3. Weak or dead battery. 4. Blown fuse. 5. Corroded battery terminals. 6. Loose or damaged wiring. 7. Faulty ignition switch. 8. Faulty solenoid or starter. 9. Faulty operator presence switch(es). | <ol style="list-style-type: none"> 1. Depress brake pedal. 2. Disengage attachment clutch. 3. Recharge or replace battery. 4. Replace fuse. 5. Clean battery terminals. 6. Check all wiring. 7. Check/replace ignition switch. 8. Check/replace solenoid or starter. 9. Contact a Sears or other qualified service center. |
| Engine clicks but will not start | <ol style="list-style-type: none"> 1. Weak or dead battery. 2. Corroded battery terminals. 3. Loose or damaged wiring. 4. Faulty solenoid or starter. | <ol style="list-style-type: none"> 1. Recharge or replace battery. 2. Clean battery terminals. 3. Check all wiring. 4. Check/replace solenoid or starter. |
| Loss of power | <ol style="list-style-type: none"> 1. Cutting too much grass/too fast. 2. Throttle in "CHOKE" position. 3. Build-up of grass, leaves and trash under mower. 4. Dirty air filter. 5. Low oil level/dirty oil. | <ol style="list-style-type: none"> 1. Raise cutting height/reduce speed. 2. Adjust throttle control. 3. Clean underside of mower housing. 4. Clean/replace air filter. 5. Check oil level/change oil. |

TROUBLESHOOTING CHART:

See appropriate section in manual unless directed to Sears service center

| PROBLEM | CAUSE | CORRECTION |
|---|--|--|
| Loss of power (continued) | 6. Faulty spark plug. 7. Dirty fuel filter. 8. Stale or dirty fuel. 9. Water in fuel. 10. Spark plug wire loose. 11. Dirty engine air screen/fins. 12. Dirty/clogged muffler. 13. Loose or damaged wiring. 14. Carburetor out of adjustment. 15. Engine valves out of adjustment. | 6. Clean and regap or change spark plug. 7. Replace fuel filter. 8. Empty fuel tank and refill tank with fresh, clean gasoline. 9. Empty fuel tank and carburetor, refill tank with fresh gasoline and replace fuel filter. 10. Connect and tighten spark plug wire. 11. Clean engine air screen/fins. 12. Clean/replace muffler. 13. Check all wiring. 14. See "To Adjust Carburetor" in Service and Adjustments section. 15. Contact a Sears or other qualified service center. |
| Excessive vibration | 1. Worn, bent or loose blade. 2. Bent blade mandrel. 3. Loose/damaged part(s). | 1. Replace blade. Tighten blade bolt. 2. Contact a Sears or other qualified service center. 3. Tighten loose part(s). Replace damaged parts. |
| Engine continues to run when operator leaves seat with attachment clutch engaged | 1. Faulty operator-safety presence control system. | 1. Check wiring, switches and connections. If not corrected, contact a Sears or other qualified service center. |
| Poor cut - uneven | 1. Worn, bent or loose blade. 2. Mower deck not level. 3. Buildup of grass, leaves, and trash under mower. 4. Bent blade mandrel. 5. Clogged mower deck vent from build-up of grass, leaves, and trash around mandrels. | 1. Replace blade. Tighten blade bolt. 2. Level mower deck. 3. Clean underside of mower housing. 4. Contact a Sears or other qualified service center. 5. Clean around mandrels to open vent holes. |
| Mower blades will not rotate | 1. Obstruction in clutch mechanism. 2. Worn/damaged mower drive belt. 3. Frozen idler pulley. 4. Frozen blade mandrel. | 1. Remove obstruction. 2. Replace mower drive belt. 3. Replace idler pulley. 4. Contact a Sears or other qualified service center. |
| Poor grass discharge | 1. Engine speed too slow. 2. Travel speed too fast. | 1. Place throttle control in "FAST" position. 2. Shift to slower speed. |

TROUBLESHOOTING CHART:

See appropriate section in manual unless directed to Sears service center

| PROBLEM | CAUSE | CORRECTION |
|---|--|---|
| Poor grass discharge (continued) | 3. Wet grass. 4. Mower deck not level. 5. Low/uneven tire air pressure. 6. Worn, bent or loose blade. 7. Buildup of grass, leaves and trash under mower. 8. Mower drive belt worn. 9. Blades improperly installed. 10. Improper blades used. 11. Clogged mower deck vent holes from buildup of grass, leaves, and trash around mandrels. | 3. Allow grass to dry before mowing. 4. Level mower deck. 5. Check tires for proper air pressure. 6. Replace/sharpen blade. Tighten blade bolt. 7. Clean underside of mower housing. 8. Replace mower drive belt. 9. Reinstall blades sharp edge down. 10. Replace with blades listed in this manual. 11. Clean around mandrels to open vent holes. |
| Headlight(s) not working (if so equipped) | 1. Switch is "OFF". 2. Bulb(s) or lamp(s) burned out. 3. Faulty light switch. 4. Loose or damaged wiring. 5. Blown fuse. | 1. Turn switch "ON". 2. Replace bulb(s) or lamp(s). 3. Check/replace light switch. 4. Check wiring and connections. 5. Replace fuse. |
| Battery will not charge | 1. Bad battery cell(s). 2. Poor cable connections. 3. Faulty regulator (if so equipped). 4. Faulty alternator. | 1. Replace battery. 2. Check/clean all connections. 3. Replace regulator. 4. Replace alternator. |
| Loss of drive | 1. Freewheel control in "disengaged" position. 2. Motion drive belt worn, damaged, or broken. 3. Air trapped in transmission during shipment or servicing. | 1. Place freewheel control in "engaged" position. 2. Replace motion drive belt. 3. Purge transmission. |
| Engine "backfires" when turning engine "OFF" | 1. Engine throttle control not set at "SLOW" position for 30 seconds before stopping engine. | 1. Move throttle control to "SLOW" position and allow to idle for 30 seconds before stopping engine. |

TRACTOR - - MODEL NUMBER 917.273281

SCHEMATIC

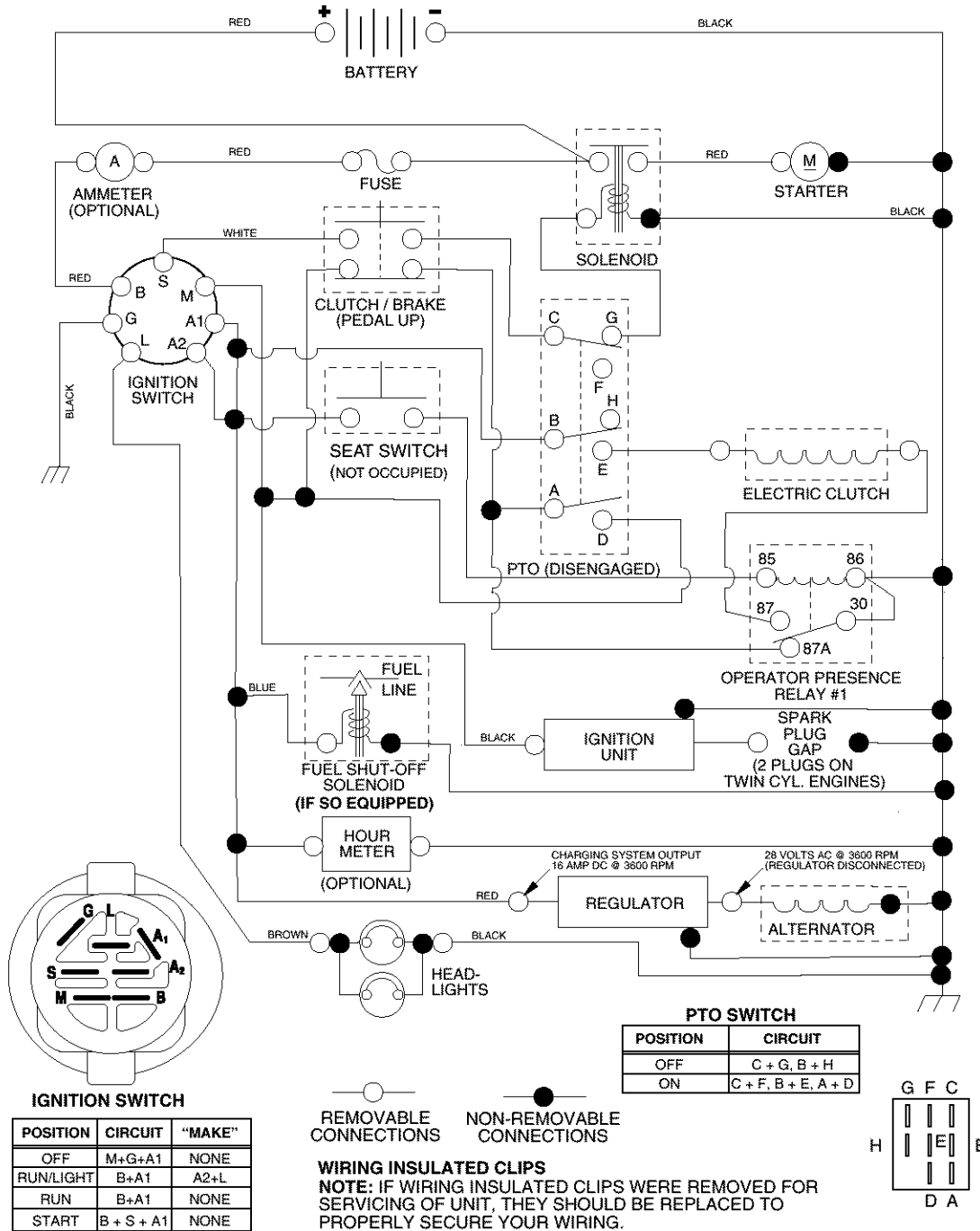

REPAIR PARTS

TRACTOR - - MODEL NUMBER 917.273281

ELECTRICAL

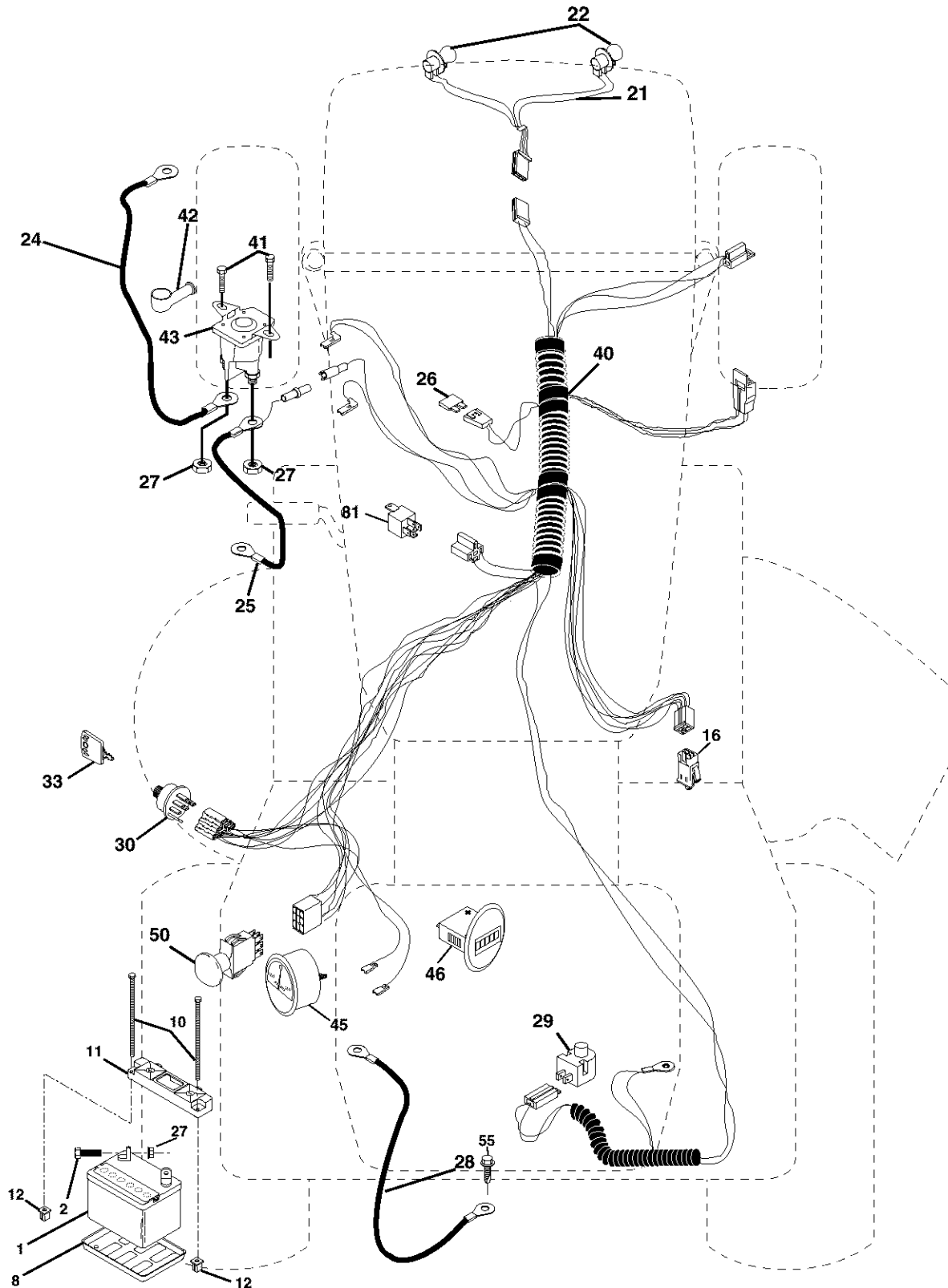

ELECTRICAL**TRACTOR - - MODEL NUMBER 917.273281**

| KEY NO. | PART NO. | DESCRIPTION |
|--------------------|---------------------|--------------------------------------|
| 1 | 144927 | Battery |
| 2 | 74760412 | Bolt, Hex 1/4-20 x 3/4 |
| 8 | 7603J | Tray, Battery |
| 10 | 145211 | Bolt, Battery, Front 1/4-20 x 7-1/2 |
| 11 | 150109 | Holddown, Battery, Front |
| 12 | 145769 | Nut, Push, Nylon, Battery, Front 1/4 |
| 16 | 176138 | Switch, Interlock |
| 21 | 175688 | Harness, Light |
| 22 | 4152J | Bulb Light #1156 |
| 24 | 8860R | Cable Starter |
| 25 | 146148 | Cable |
| 26 | 175158 | Fuse |
| 27 | 73510400 | Nut, Hex, Keps 1/4-20 unc |
| 28 | 145491 | Cable, Ground |
| 29 | 160784 | Switch, Seat |
| 30 | 175442 | Switch, Ignition |
| 33 | 175447 | Key |
| 40 | 179737 | Harness, Ignition |
| 41 | 71110408 | Bolt Blk Fin Hex 1/4-20 x 1/2 |
| 42 | 131563 | Cover Terminal |
| 43 | 178861 | Solinoid w/brass plunger |
| 45 | 177500 | Ammeter |
| 46 | 177501 | Hourmeter |
| 50 | 178461 | Switch, PTO |
| 55 | 17490508 | Screw, Thd. Roll. 5/16-18 x 1/2 |
| 81 | 109748X | Relay Assembly |

NOTE: All component dimensions given in U.S. inches
1 inch = 25.4 mm

TRACTOR - - MODEL NUMBER 917.273281

CHASSIS AND ENCLOSURES

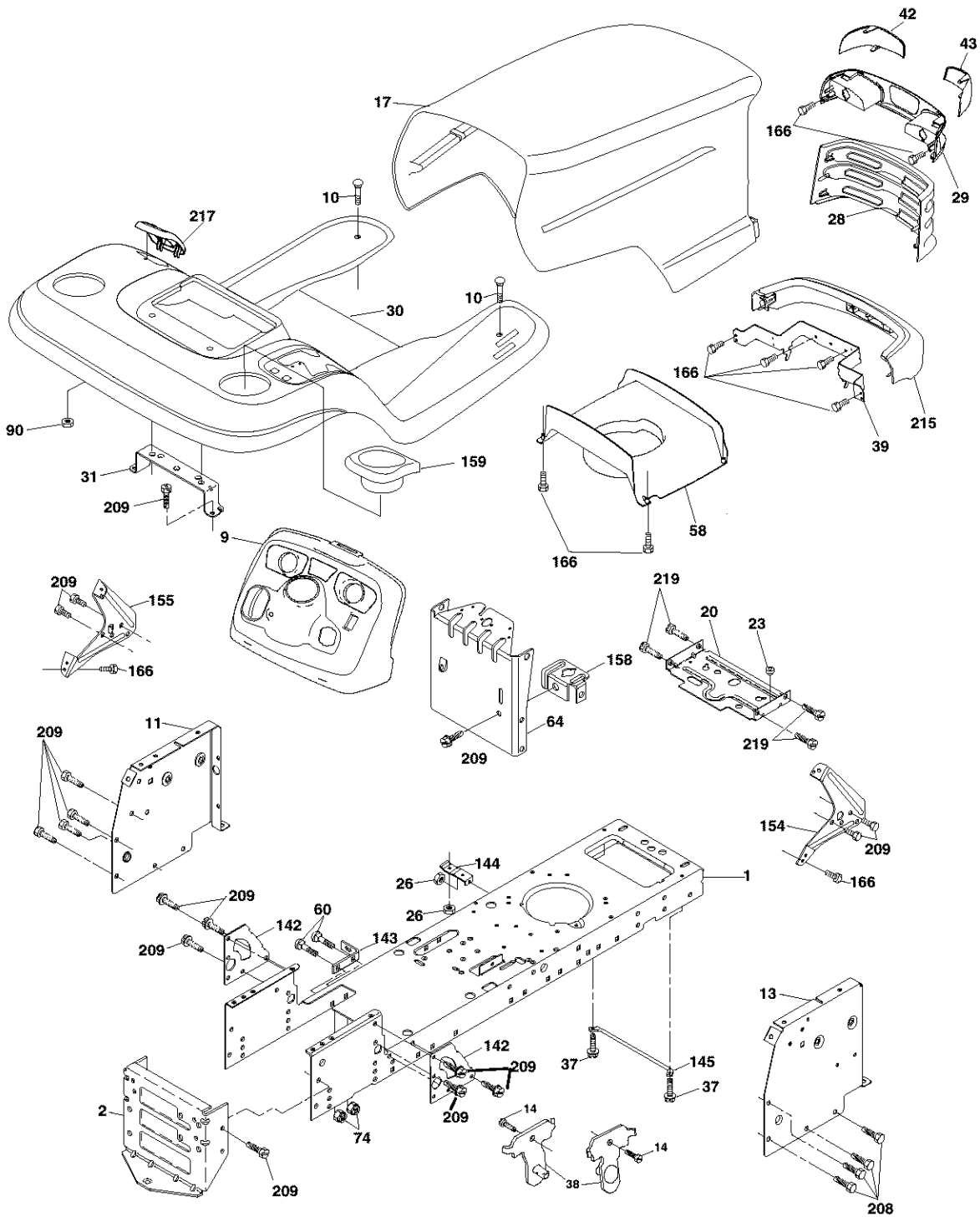

chassis-LTX-stlt_10

**TRACTOR - - MODEL NUMBER 917.273281
CHASSIS AND ENCLOSURES**

| KEY NO. | PART NO. | DESCRIPTION |
|--------------------|---------------------|--------------------------------------|
| 1 | 174619 | Chassis |
| 2 | 176554 | Drawbar |
| 9 | 172542X418 | Dash |
| 10 | 72140608 | Bolt RDHD SQNK 3/8-16 x 1 |
| 11 | 174996 | Panel, Dash, LH |
| 13 | 179174X010 | Panel, Dash, RH |
| 14 | 17490608 | Screw Thdrol 3/8-16 x 1/2 |
| 17 | 172540X615 | Hood Assembly |
| 20 | 180679 | Plate Battery |
| 23 | 124028X | Bushing Snap |
| 26 | STD541437 | Locknut, Hex, with Insert 3/8-16 unc |
| 28 | 174945X418 | Grille |
| 29 | 177849X418 | Lightbox Dual |
| 30 | 179131X615 | Fender/Footrest |
| 31 | 139976 | Bracket, Fender/Support |
| 37 | 17490508 | Screw, Thdrol. 5/16-18 x 1/2 TYT |
| 38 | 175710 | Bracket Asm Pivot Mower Rear |
| 39 | 174988 | Bracket Pivot Hood |
| 42 | 172545X599 | Lens Lh |
| 43 | 172544X599 | Lens Rh |
| 58 | 174993 | Duct Hood |
| 60 | STD533707 | Bolt Rdhd Sqnk 3/8-16 unc x 3/4 |
| 64 | 174997 | Dash Lower |
| 74 | STD541437 | Nut Crownlock 3/8-16 unc |
| 90 | 124346X | Nut Self Thrd Wshd 1/4 Zinc |
| 142 | 175702 | Plate Reinforcement |
| 143 | 154966 | Bracket Swaybar Chassis |
| 144 | 175582 | Bracket Footrest |
| 145 | 156524 | Rod Pivot Chassis/Hood |
| 154 | 174679 | Bracket Dash Rh |
| 155 | 174680 | Bracket Dash Lh |
| 158 | 162037 | Parking Brake Bkrt |
| 159 | 179950X418 | Cupholder |
| 166 | 171875 | Screw HWHDH:-Lo. #13-16 x 3/4 |
| 208 | 17670608 | Screw Thdrol 3/8-16 x 1/2 |
| 209 | 17000612 | Screw Hexwsh Thdr 3/8-16 x 3/4 |
| 215 | 172543X615 | Bumper |
| 217 | 179132X418 | Console Fuel Window |
| 219 | 17000512 | Screw 5/16-18 x 3/4 |

NOTE: All component dimensions given in U.S. inches
1 inch = 25.4 mm

TRACTOR - - MODEL NUMBER 917.273281
GROUND DRIVE

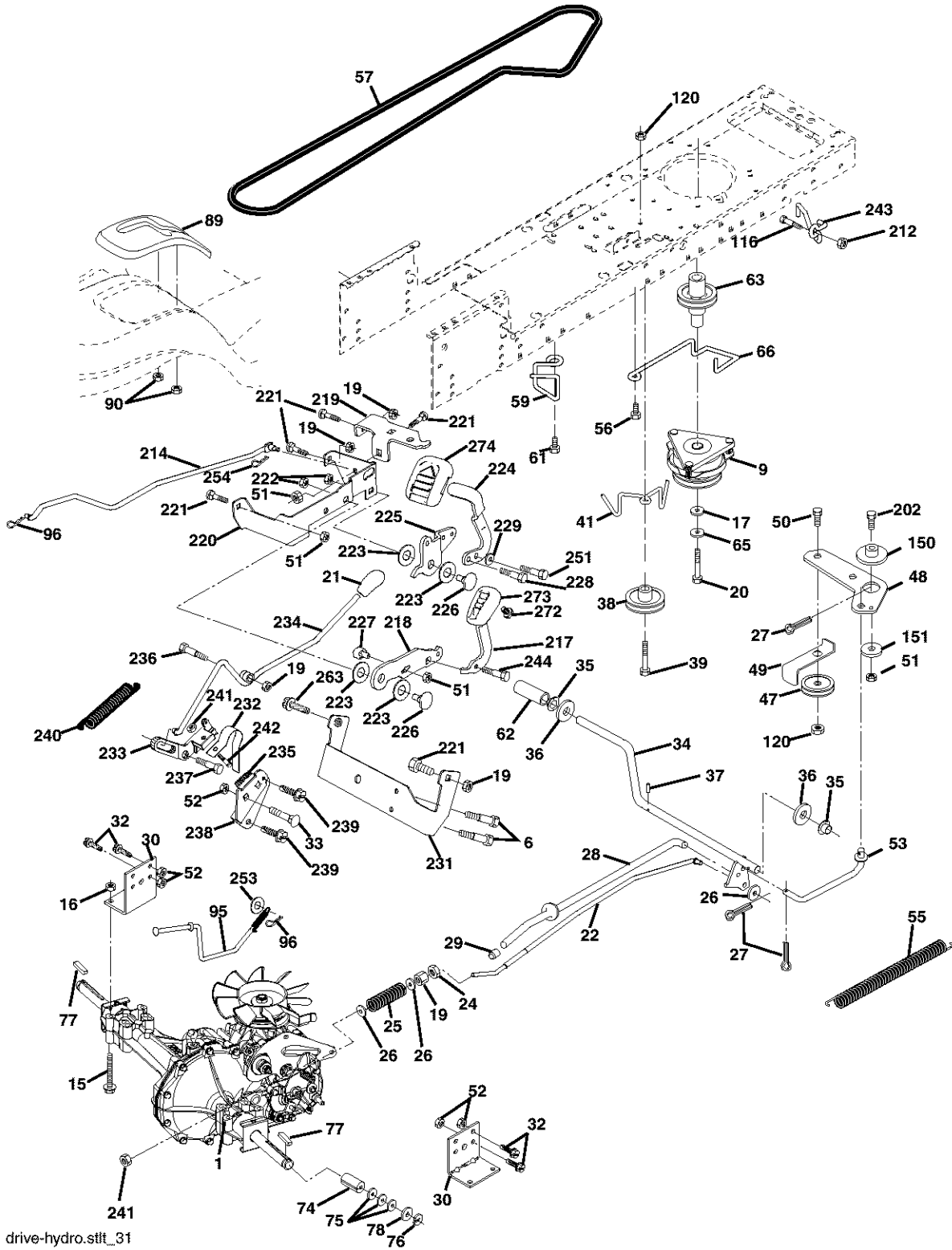

TRACTOR - - MODEL NUMBER 917.273281

GROUND DRIVE

| KEY NO. | PART NO. | DESCRIPTION | KEY NO. | PART NO. | DESCRIPTION |
|---------|------------|--|---------|------------|-----------------------------------|
| 1 | --- | Transaxle, HydroGear, Model Number 336-0510 (See Break down) | 78 | 121748X | Washer 25/32 x 1-5/8 x 16 Ga. |
| 6 | 17060512 | Screw 5/16-18 | 89 | 174901X418 | Console, Shift |
| 9 | 179334 | Clutch Electric | 90 | 124346X | Nut Self-Thd Wsh-hd 1/4 Zinc |
| 15 | 74490544 | Bolt Hex Flghd 5/16-18 Gr. 5 | 95 | 180825 | Rod Bypass |
| 16 | 73800500 | Nut Lock Hex W/Ins. 5/16-18 unc | 96 | 4497H | Retainer Spring 1" Zinc/Cad |
| 17 | 126197X | Washer 1-1/2 OD x 15/32 ID x.250 | 116 | 72140608 | Bolt RDHD SQNK 3/8-16 unc x 1 |
| 19 | 73800600 | Nut Lock Hex W/Wsh 3/8-16 unc | 120 | 73900600 | Nut Lock Flg 3/8-16 unc |
| 20 | 173937 | Bolt Hex 7/16-20 x 4 x Gr. 5-1.5 | 150 | 175456 | Spacer Retainer |
| 21 | 175036X505 | Knob Custom Control Cruise | 151 | 19133210 | Washer 13/32 x 2 x 10 Ga. |
| 22 | 175896 | Rod, Brake | 202 | 72110614 | Bolt Carr Sh 3/8-16 x 1-3/4 Gr. 5 |
| 24 | 73350600 | Nut, Hex Jam 3/8-16 unc | 212 | 145212 | Nut HexFlange Lock |
| 25 | 106888X | Spring, Brake Rod | 214 | 174735 | Link Transaxle |
| 26 | 19131316 | Washer | 217 | 179433 | Pedal Assy, Reverse, with Pad |
| 27 | 76020412 | Pin Cotter 1/8 x 3/4 CAD. | 218 | 174713 | Arm Control Pedal Reverse |
| 28 | 179607 | Rod, Parking Brake | 219 | 174839 | Bracket Frest Pdl Ctrl. Hyd |
| 29 | 179608X505 | Knob Brake Parking | 220 | 174711 | Bracket Mtg. Pedal Control |
| 30 | 169592 | Bracket, Transaxle | 221 | 72140606 | Bolt Rdhd Sqnk 3/8-16 unc x 3/4 |
| 32 | 74760512 | Bolt Hex Hd 5/16-18 unc x 3/4 | 222 | 73680700 | Nut Crownlock 7/16-14 unc |
| 33 | 72140506 | Bolt Rdhd Sqnk 5/16-18 unc x 3/4 | 223 | 174840 | Washer Nylon 11/16 ID x .060 |
| 34 | 175578 | Shaft, Foot Pedal | 224 | 174736 | Pedal Forward |
| 35 | 120183X | Bearing, Nylon | 225 | 174712 | Arm Control Pedal Forward |
| 36 | 19211616 | Washer | 226 | 174902 | Bolt Pivot Spacer |
| 37 | 1572H | Pin, Roll | 227 | 174710 | Cam Reverse Pedal LT |
| 38 | 179114 | Pulley, Composite | 228 | 179032 | Bolt Shoulder 5/16-18 |
| 39 | 74760648 | Bolt Fin Hex 3/8-16 unc x 3 | 229 | 176451 | Washer Serrated 5/16 x .75 |
| 41 | 175556 | Keeper, Belt Idler Flat | 231 | 174573 | Strap Torque |
| 47 | 127783 | Pulley, Idler, V-Groove | 232 | 175570 | Actuator Cruise Disengage |
| 48 | 154407 | Bellcrank Clutch Grnd Drw Stl | 233 | 174856 | Pawl Control Cruise |
| 49 | 123205X | Retainer, Belt | 234 | 174858 | Lever Control Cruise |
| 50 | 72110612 | Bolt | 235 | 174857 | Sector Control Cruise |
| 51 | 73680600 | Nut Crownlock 3/8-16 unc | 236 | 128903 | Bolt Shoulder 3/8-16 unc 1/44 |
| 52 | 73680500 | Nut, Crownlock 5/16-18 unc | 237 | 170165 | Bolt Shoulder 5/16-18 |
| 53 | 105710X | Link, Clutch | 238 | 175807 | Arm Mtg. Cruise Sector |
| 55 | 105709X | Spring, Return, Clutch | 239 | 17490508 | Screw Thdrol 5/16 x 1/2 |
| 56 | 17060620 | Screw 3/8-16 x 1-1/4 | 240 | 175610 | Spring Return Cruise Control |
| 57 | 140294 | V-Belt, Ground Drive | 241 | 73930400 | Nut Centerlock 1/4-20 unc |
| 59 | 169691 | Keeper, Center Span | 242 | 74780412 | Bolt Fin Hex 1/4-20 unc x 3/4 |
| 61 | 17120614 | Screw 3/8-16 x .875 | 243 | 178289 | Bracket Anti-Rotation CVX |
| 62 | 123533X | Cover, Pedal | 244 | 166880 | Screw 5/16-18 x 5/8 TT Yellow |
| 63 | 174607 | Pulley, Engine | 271 | 17000612 | Screw 3/8-16 x .75 |
| 65 | 10040700 | Washer | 251 | 17060516 | Screw 5/16-18 x 1 |
| 66 | 154778 | Keeper Belt Engine | 253 | 179422 | Washer |
| 74 | 137057 | Spacer, Axle | 254 | 178062 | Clip Retainer |
| 75 | 121749X | Washer 25/32 x 1-1/4 x 16 Ga. | 272 | 17670508 | Screw, 5/16-18 x 1/2 TT |
| 76 | 12000001 | E-Ring | 273 | 179610 | Pad, Reverse Pedal |
| 77 | 123583X | Key, Square | 274 | 175646 | Cover Pedal Forward |

NOTE: All component dimensions given in U.S. inches
1 inch = 25.4 mm

TRACTOR - - MODEL NUMBER 917.273281
STEERING ASSEMBLY

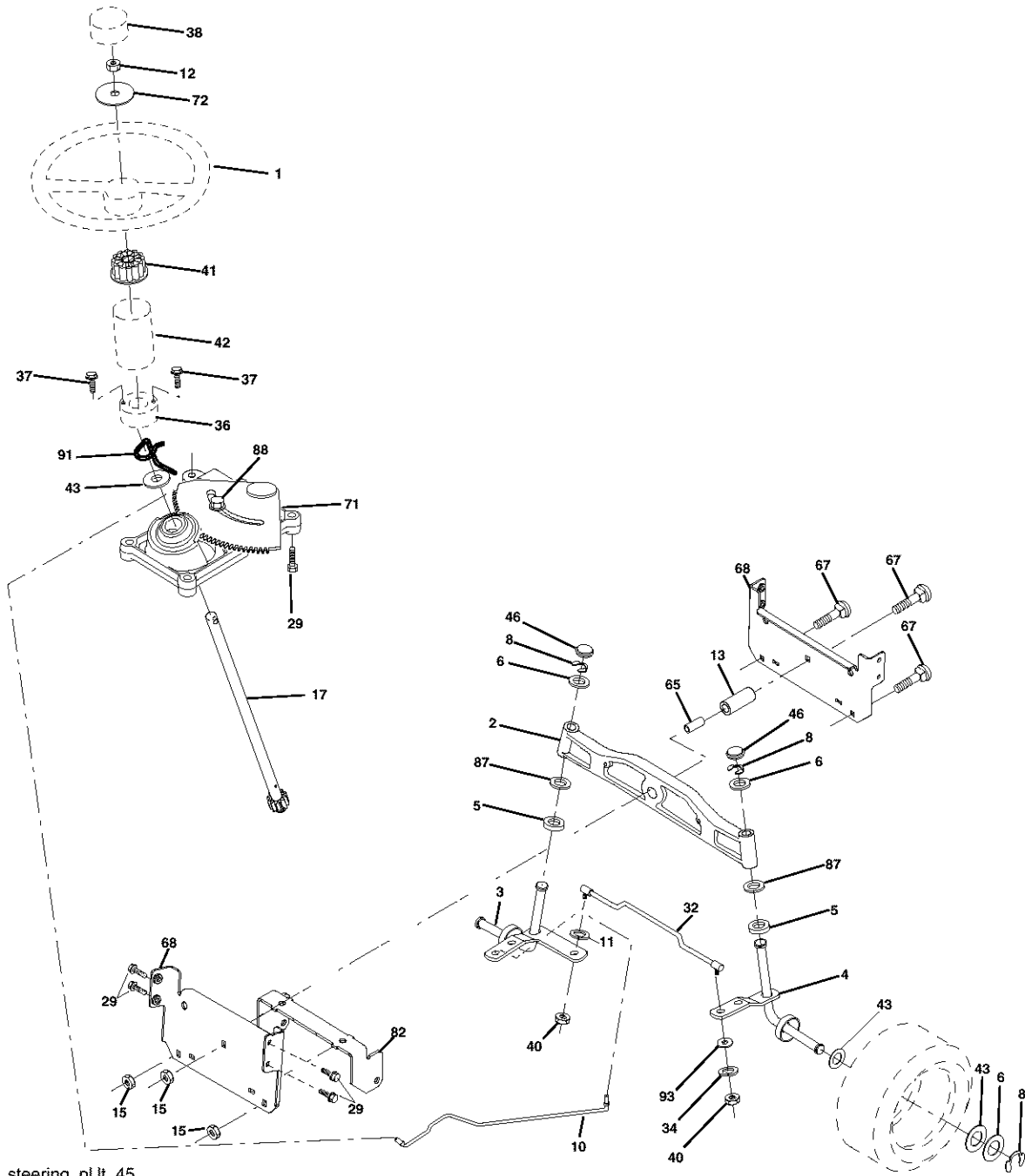

steering_pl.it_45

TRACTOR - - MODEL NUMBER 917.273281
STEERING ASSEMBLY

| KEY | PART | |
|------------|-------------|----------------------------------|
| NO. | NO. | DESCRIPTION |
| 1 | 175139X418 | Wheel Steering |
| 2 | 184706 | Axle Asm |
| 3 | 169840 | Spindle Asm LH |
| 4 | 169839 | Spindle Asm RH |
| 5 | 6266H | Bearing Race Thrust Harden |
| 6 | 121748X | Washer 25/32 x 1-5/8 x 16 Ga. |
| 8 | 12000029 | Ring Klip #t5304-75 |
| 10 | 175121 | Link Drag |
| 11 | STD551137 | Washer Lock Hvy Hlcl Spr 3/8 |
| 12 | 73940800 | Nut Hex Jam Toplock 1/2-20 unf |
| 13 | 136518 | Spacer Bearing Axle Front |
| 15 | 145212 | Nut Hex Flange Lock |
| 17 | 177883 | Shaft Asm. Steering |
| 29 | 17000612 | Screw 3/8-16 x 3/4 |
| 32 | 180580 | Rod Tie |
| 34 | 10040600 | Washer Lock Hlcl Spr 3/8 |
| 36 | 155105 | Bushing Strg |
| 37 | 152927 | Screw |
| 38 | 175140X418 | Insert Cap Strg Wh |
| 40 | STD541537 | Lock nut Center 3/8-24 |
| 41 | 159945 | Adaptor Wheel Strg |
| 42 | 174530X418 | Boot Steering |
| 43 | 121749X | Washer 25/32 1 1/4 x 16 Ga. |
| 46 | 184946X505 | Cap Spindle |
| 65 | 160367 | Spacer Brace Axle |
| 67 | 72140618 | Bolt, Rdhd Sq 3/8-16 unc x 2-1/4 |
| 68 | 169827 | Axle, Brace |
| 71 | 175146 | Steering Asm. |
| 72 | 19182411 | Washer 9/16 ID x 1-1/2 OD 11 Ga. |
| 82 | 169835 | Bracket Susp. Chassis Front |
| 87 | 173966 | Washer Flat .781 x 1-1/2 x .15 |
| 88 | 175118 | Bolt Shoulder 7/16-20 unc |
| 91 | 175553 | Clip Steering |
| 93 | 19121214 | Washer 3/8 x 3/4 x 14 Ga. |
| -- | 17490608 | Screw Thdrol 3/8-16 x 1/2 |

NOTE: All component dimensions given in U.S. inches
1 inch = 25.4 mm

TRACTOR - - MODEL NUMBER 917.273281

ENGINE

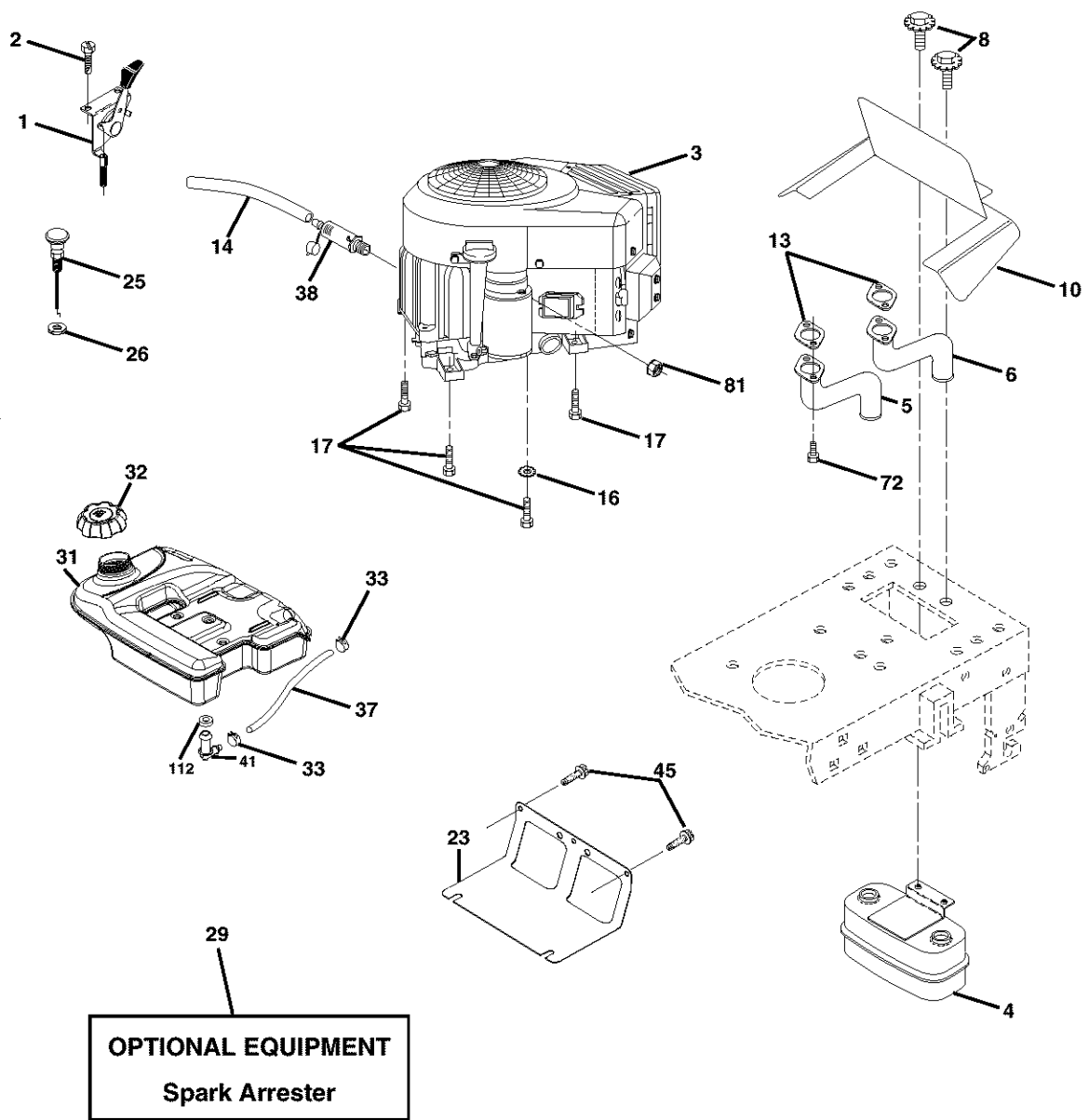

engine-bs intek-twin_39

TRACTOR - - MODEL NUMBER 917.273281

ENGINE

| KEY NO. | PART NO. | DESCRIPTION |
|------------|-------------|--|
| 1 | 175437X428 | Control Throttle |
| 2 | 171875 | Screw Hwhd Hi-Lo #13-16 x 3/4 |
| 3 | ----- | Engine, Briggs Model 407777-0121-E4 (See Breakdown) |
| 4 | 149723 | Muffler Asm Twin Lo-Tone |
| 5 | 159955 | Pipe Exhaust LH Intek |
| 6 | 160589 | Pipe Exhaust RH Intek |
| 8 | 171877 | Bolt 5/16-18 unc x 3/4 w/Sems |
| 10 | 162797 | Shield Browning Intek II |
| 13 | 165391 | Muffler Gasket |
| 14 | 148456 | Tube Drain oil |
| 16 | 11050600 | Washer Lock Ext Tooth 3/8 |
| 17 | 17060624 | Screw Thdrol 3/8-16 x 1-1/2 |
| 23 | 169837 | Shield Heat |
| 25 | 175440X428 | Choke Control |
| 26 | 73920600 | Nut, Keps 3/8-24 unf |
| 29 | 137180 | Kit Spark Arrestor (Flat Scrn) |
| 31 | 179022 | Tank Fuel 4.0 Rear |
| 32 | 179124X428 | Cap Asm Fuel |
| 33 | 123487X | Clamp Hose Black |
| 37 | 8543R | Line Fuel |
| 38 | 181654 | Plug Drain Oil Easy |
| 41 | 139277 | Stem Tank Fuel |
| 45 | 17000612 | Screw Hexwsh Thdr 3/8-16 x 3/4 |
| 72 | 183906 | Screw 5/16-18 x 1 |
| 81 | 73510400 | Nut Keps Hex 1/4-20 unc |
| 112 | 3645J | Bushing |

NOTE: All component dimensions given in U.S. inches
1 inch = 25.4 mm

TRACTOR - - MODEL NUMBER 917.273281
SEAT ASSEMBLY

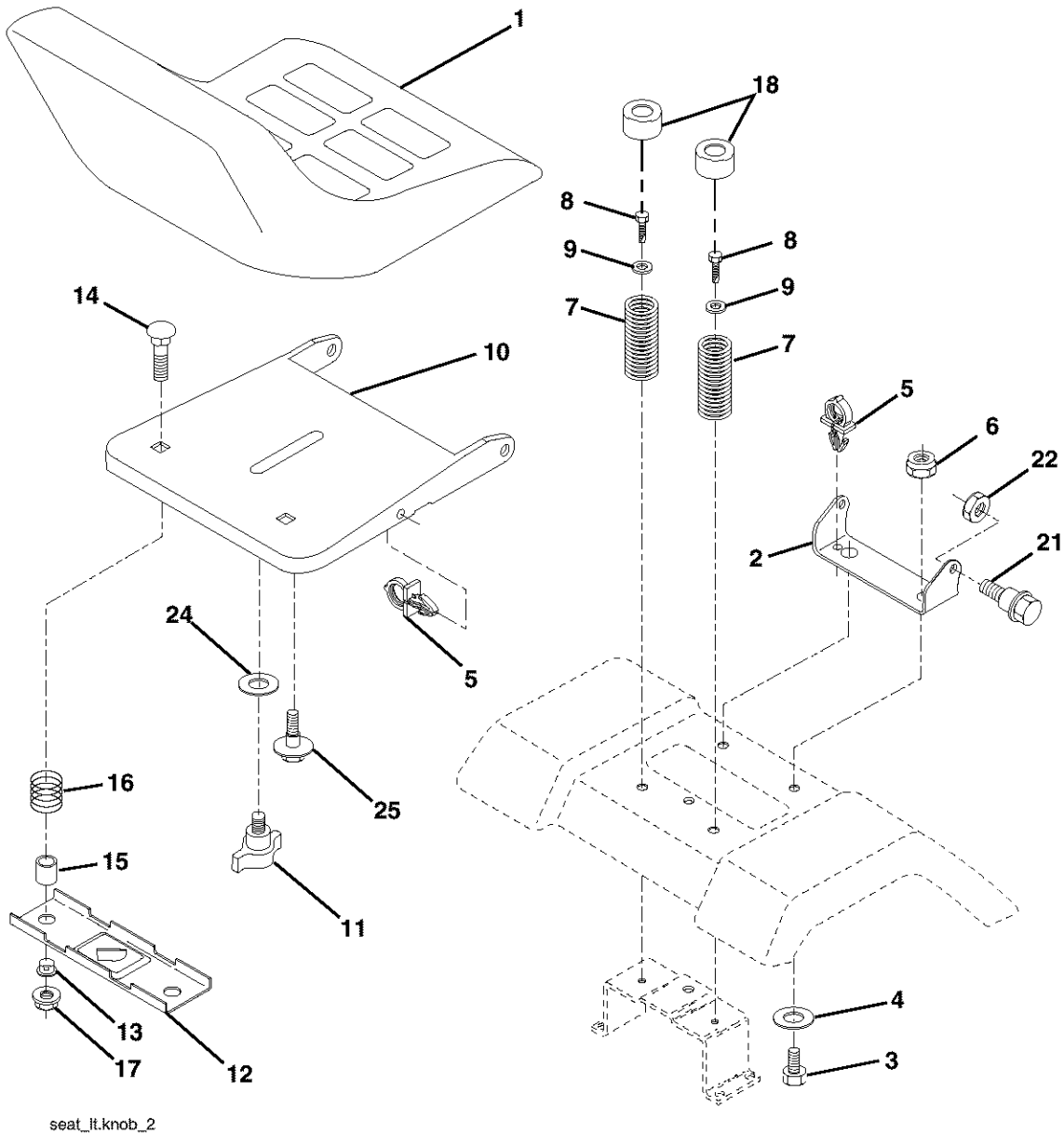

seat_lt.knob_2

**KEY PART
 NO. NO.**

| KEY PART NO. | NO. | DESCRIPTION |
|--------------|-----------|-----------------------------|
| 1 | 175134 | Seat |
| 2 | 140551 | Bracket Pivot Seat 8 720 |
| 3 | STD523710 | Bolt Fin Hex 3/8-16 unc x 1 |
| 4 | 19131610 | Washer 13/32 x 1 x 10 Ga. |
| 5 | 145006 | Clip Push-In |
| 6 | STD541437 | Nut Hex w/Ins. 3/8-16 unc |
| 7 | 124181X | Spring Seat Cprsn |
| 8 | 17000616 | Screw 3/8-16 x 1-1/2 |
| 9 | 19131614 | Washer 13/32 x 1 x 14 Ga. |
| 10 | 182493 | Pan Seat |
| 11 | 177957 | Knob Seat Adj. Wingnut |
| 12 | 121246X | Bracket Mounting Switch |

**KEY PART
 NO. NO.**

| KEY PART NO. | NO. | DESCRIPTION |
|--------------|-----------|---------------------------------|
| 13 | 121248X | Bushing Snap Blk Nyl 50 Id |
| 14 | 72050412 | Bolt Rdhd Sqnk 1/4-20 x 1-1/2 |
| 15 | 121249X | Spacer Split 28x .88 Zinc |
| 16 | 123740X | Spring Cprsn Plate 1.310 Ga. |
| 17 | 123976X | Nut Lock 1/4 Lge Flg Gr. 5 Zinc |
| 18 | 124238X | Cap Spring Seat |
| 21 | 171852 | Bolt Shoulder 5/16-18 unc |
| 22 | STD541431 | Nut Hex Lock W/Ins 5/16-18 |
| 24 | 19171912 | Washer 17/32 x 1-3/16 x 12 Ga. |
| 25 | 127018X | Bolt Shoulder 5/16-18 x 62 |

NOTE: All component dimensions given in U.S. inches
 1 inch = 25.4 mm

TRACTOR - - MODEL NUMBER 917.273281

DECALS

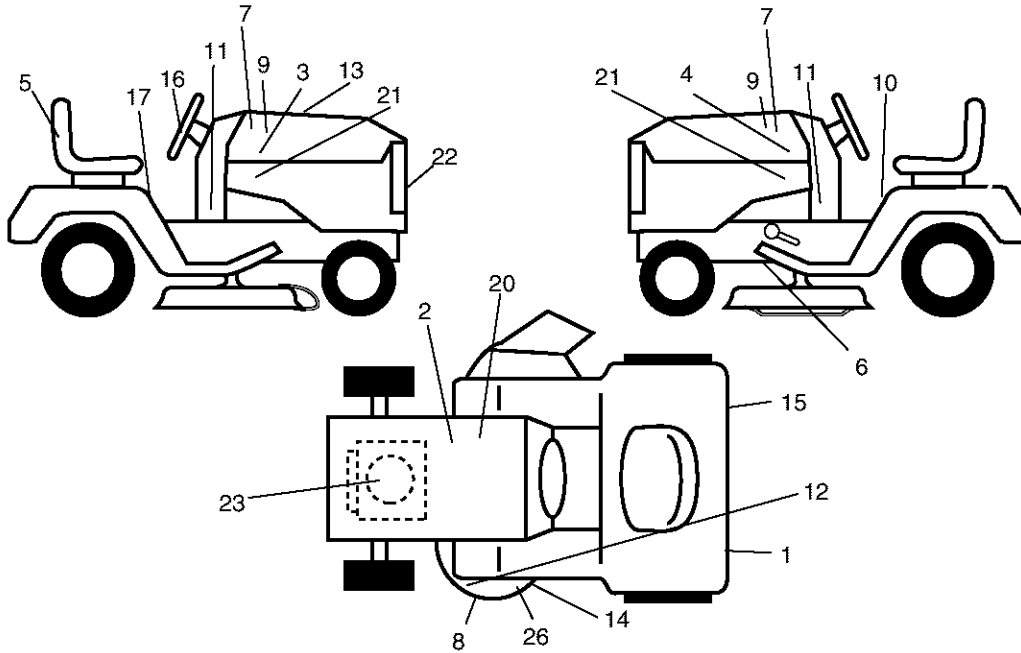

KEY PART NO. NO.

| KEY PART NO. | NO. | DESCRIPTION |
|--------------|--------|--------------------------------|
| 1 | 187407 | Reflector, LH |
| 2 | 138047 | Decal, Battery, Diehard, Sears |
| 3 | 186329 | Decal, Hood RH |
| 4 | 186330 | Decal, Hood LH |
| 5 | 180978 | Decal, Seat Craftsman |
| 6 | 146046 | Decal, V-Belt, Drive Schematic |
| 7 | 180978 | Decal, Hood |
| 8 | 178455 | Decal, Deck, Caution |
| 9 | 186447 | Decal, Replacement Hood |
| 10 | 156439 | Decal, Fender, Danger |
| 11 | 180448 | Decal, Panel, Dash |
| 12 | 178482 | Decal, Mower, Heavy-Duty |
| 13 | 133644 | Decal, Replacement Parts |
| 14 | 175291 | Decal, V-Belt, Schematic |

KEY PART NO. NO.

| KEY PART NO. | NO. | DESCRIPTION |
|--------------|------------|--------------------------------|
| 15 | 187408 | Decal, Reflector, RH |
| 16 | 177890 | Decal, Steering Wheel |
| 17 | 177955 | Decal, Fender, Cruise |
| 20 | 149516 | Decal, Battery |
| 21 | 186331 | Decal, Hood, Side Panel |
| 22 | 177889 | Decal, Grille |
| 23 | 180438 | Decal, Engine |
| 26 | 181470 | Decal, Deck level |
| -- | 174998X418 | Pad, Footrest, ST/LT, LH |
| -- | 175542X418 | Pad, Footrest, ST/LT, RH |
| -- | 138311 | Decal Handle Lft Height Adjust |
| -- | 166960 | Decal By-Pass |
| -- | 188071 | Manual, Owner's, English |
| -- | 188072 | Manual, Owner's, Spanish |

WHEELS & TIRES

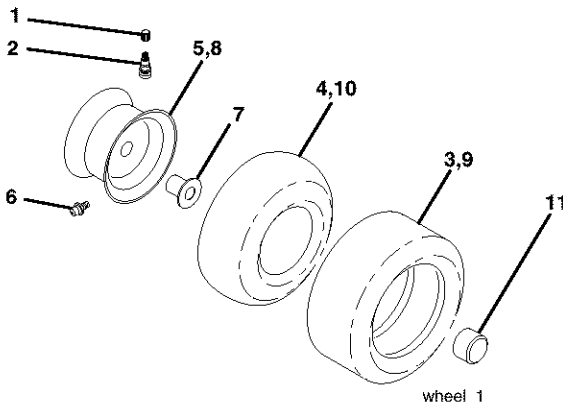

KEY PART NO. NO.

| KEY PART NO. | NO. | DESCRIPTION |
|--------------|------------|-----------------------------------|
| 1 | 59192 | Cap Valve Tire |
| 2 | 65139 | Stem Valve |
| 3 | 106222X | Tire F Ts 15 x 6 0 - 6 Service |
| 4 | 59904 | Tube Front (Service Item Only) |
| 5 | 106732X417 | Rim Asm 6"front Service |
| 6 | 278H | Fitting Grease (Front Wheel Only) |
| 7 | 9040H | Bearing Flange (Front Wheel Only) |
| 8 | 106108X417 | Rim Asm 8"rear Service |
| 9 | 122082X | Tire R Ts 20 x 10-8 C Service |
| 10 | 7152J | Tube Rear (Service Item Only) |
| 11 | 104757X417 | Cap Axle Blk 1 50 x 1 00 |
| -- | 144334 | Sealant, Tire (10 oz. Tube) |

NOTE: All component dimensions given in U.S. inches
1 inch = 25.4 mm

TRACTOR -- MODEL NUMBER 917.273281
LIFT ASSEMBLY

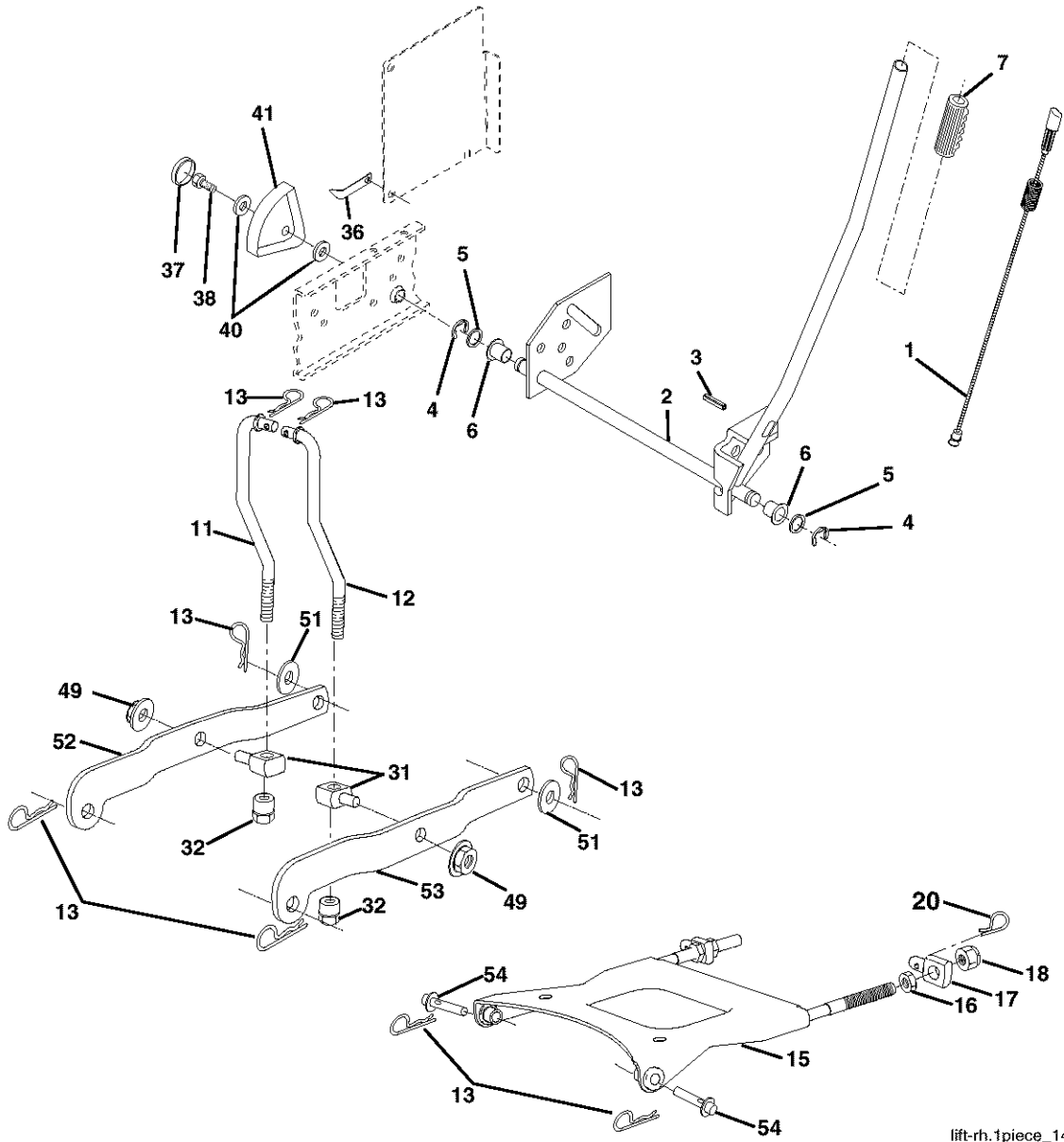

lift-rh.1piece_14

LIFT ASSEMBLY **TRACTOR - - MODEL NUMBER 917.273281**

| KEY NO. | PART NO. | DESCRIPTION |
|----------------|-----------------|------------------------------|
| 1 | 179504 | Plunger Assembly |
| 2 | 159476 | Shaft Assembly, Lift |
| 3 | 178981 | Pin, Groove |
| 4 | 12000002 | E-Ring |
| 5 | 19211621 | Washer 21/32 x 1 x 21 Ga. |
| 6 | 120183X | Bearing, Nylon |
| 7 | 175830 | Grip, Handle, Fluted |
| 11 | 175370 | Link, Lift, L.H. |
| 12 | 175371 | Link, Lift, R.H. |
| 13 | 4939M | Retainer Spring |
| 15 | 175562 | Plate Asm Suspension Front |
| 16 | 73350800 | Nut Hex Jam 1/2-13 unc |
| 17 | 175689 | Trunnion Front Susp. |
| 18 | 73800800 | Nut Lock w/Wsh 1/2-13 unc |
| 20 | 163552 | Retainer Spring |
| 31 | 176205 | Trunion Sups. Arm. |
| 32 | 175994 | Nut Lift Link 7/16-20 |
| 36 | 155097 | Pointer Height Indicator |
| 37 | 123935X | Plug Hole |
| 38 | 17060516 | Screw 5/16-18 x 1 |
| 40 | 19112410 | Washer 11/32 x 1-1/2 x 10 Ga |
| 41 | 155098 | Indicator Height Stlt |
| 49 | 145212 | Nut Hex/Large Lock |
| 51 | 19171416 | Washer 17/32 x 7/8 x 16 Ga. |
| 52 | 175378 | Arm Suspension Rear LH |
| 53 | 175802 | Arm Suspension Rear RH |
| 54 | 175560 | Pin Flange |

NOTE: All component dimensions given in U.S. inches
1 inch = 25.4 mm

TRACTOR - - MODEL NUMBER 917.273281
MOWER DECK

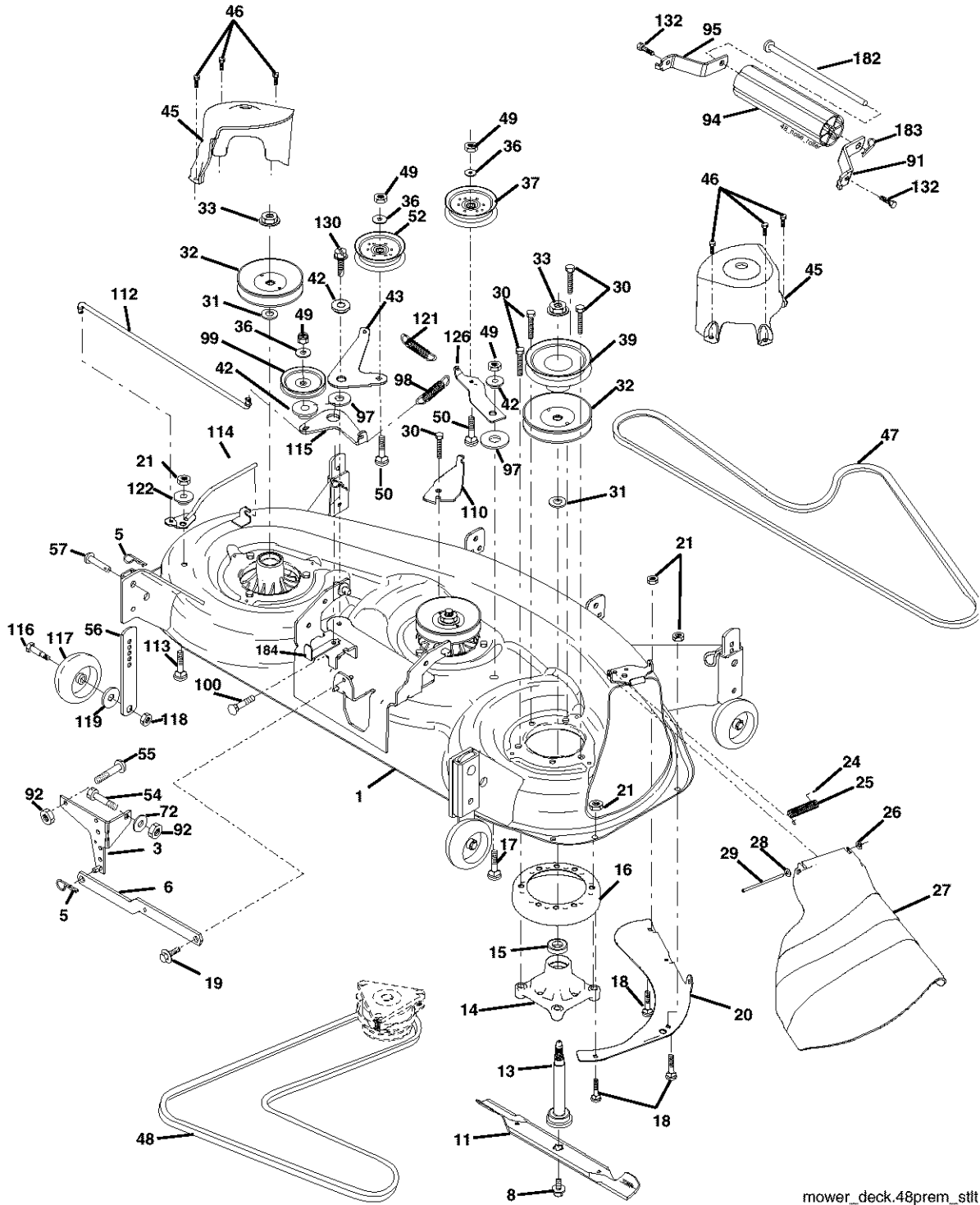

mower_deck.48prem_stlt

TRACTOR - - MODEL NUMBER 917.273281

MOWER DECK

| KEY PART NO. NO. | DESCRIPTION | KEY PART NO. NO. | DESCRIPTION |
|---------------------|-------------|---------------------|--|
| 1 | 180358 | 50 | 22110612 Bolt, Carr. 3/8-16 x 1-1/2 Gr. 5 |
| 3 | 138017 | 52 | 175820 Pulley Idler Flat |
| 5 | 4939M | 54 | 74780616 Bolt Fin Hex 3/8-16 unc x 1 Gr. 5 |
| 6 | 178024 | 55 | 72140608 Bolt Rdhd Sqnk 3/8-16 unc x 1 |
| 8 | 174365 | 56 | 155986 Bar Pnt Adj. |
| | | 57 | 156941 Pin Head Rivet |
| | | 72 | 19131312 Washer 13/32 x 13/16 x 12 Ga. |
| 11 | 173921 | 91 | 180535 Bracket Asm Noseroller RH |
| | | 92 | 73800600 Nut Lock Hex w/Ins 3/8-16 unc |
| -- | 180054 | 94 | 176066 Noseroller |
| | | 95 | 180534 Bracket Asm Noseroller LH |
| 13 | 174360 | 97 | 178515 Washer Hardened |
| 14 | 174358 | 98 | 179479 Spring Primary Drive |
| 15 | 110485X | 99 | 184058 Pulley Idler"V" |
| 16 | 174493 | 100 | 72110616 Bolt RDHD Sqnk 3/8-16 unc x 2 |
| 17 | 72110610 | 110 | 175016 Arm Spring Secondary |
| 18 | 72140505 | 112 | 174387 Link Tension Relief Lever |
| 19 | 132827 | 113 | 72110506 Bolt Carr. 5/16-18 x 3/4 |
| 20 | 174378 | 114 | 174384 Tension Asm Relief Lever |
| 21 | 73680500 | 115 | 174609 Arm Spring Tension Relief |
| 24 | 105304X | 116 | 184219 Bolt, Shoulder |
| 25 | 178102 | 117 | 174873 Gauge Wheel |
| 26 | 110452X | 118 | 73930600 Nut, Centerlock 3/8-16 unc |
| 27 | 180655X428 | 119 | 19121414 Washer 3/8 x 7/8 x 14 Ga. |
| 28 | 19111016 | 121 | 174371 Spring Secondary Drive |
| 29 | 131491 | 122 | 174606 Bushing Pivot Tension Relief |
| 30 | 173984 | 126 | 174372 Arm, Idler, Primary Deck |
| 31 | 129963 | 130 | 17000616 Screw 3/8-16 x 1 |
| 32 | 177865 | 132 | 17060612 Screw 3/8-16 x .75 |
| 33 | 178342 | 182 | 179127 Rod Roller Nose |
| 36 | 19131316 | 183 | 163552 Retainer Spring |
| 37 | 177968 | 184 | 173979 Keeper Belt Idler |
| 39 | 174375 | -- | 174356 Mandrel Asm. Service (Includes |
| 42 | 165723 | | Key Nos. 13-15) |
| 43 | 174373 | -- | 181579 Replacement Mower, Complete |
| 45 | 180806 | | (Std. Deck-Order separately nose |
| 46 | 137729 | | roller components Key Nos. 91, |
| 47 | 180808 | | 94, 95 and 132, 182, and 183.) |
| 48 | 174368 | | |
| 49 | 73680600 | | |

NOTE: All component dimensions given in U.S. inches
1 inch = 25.4 mm

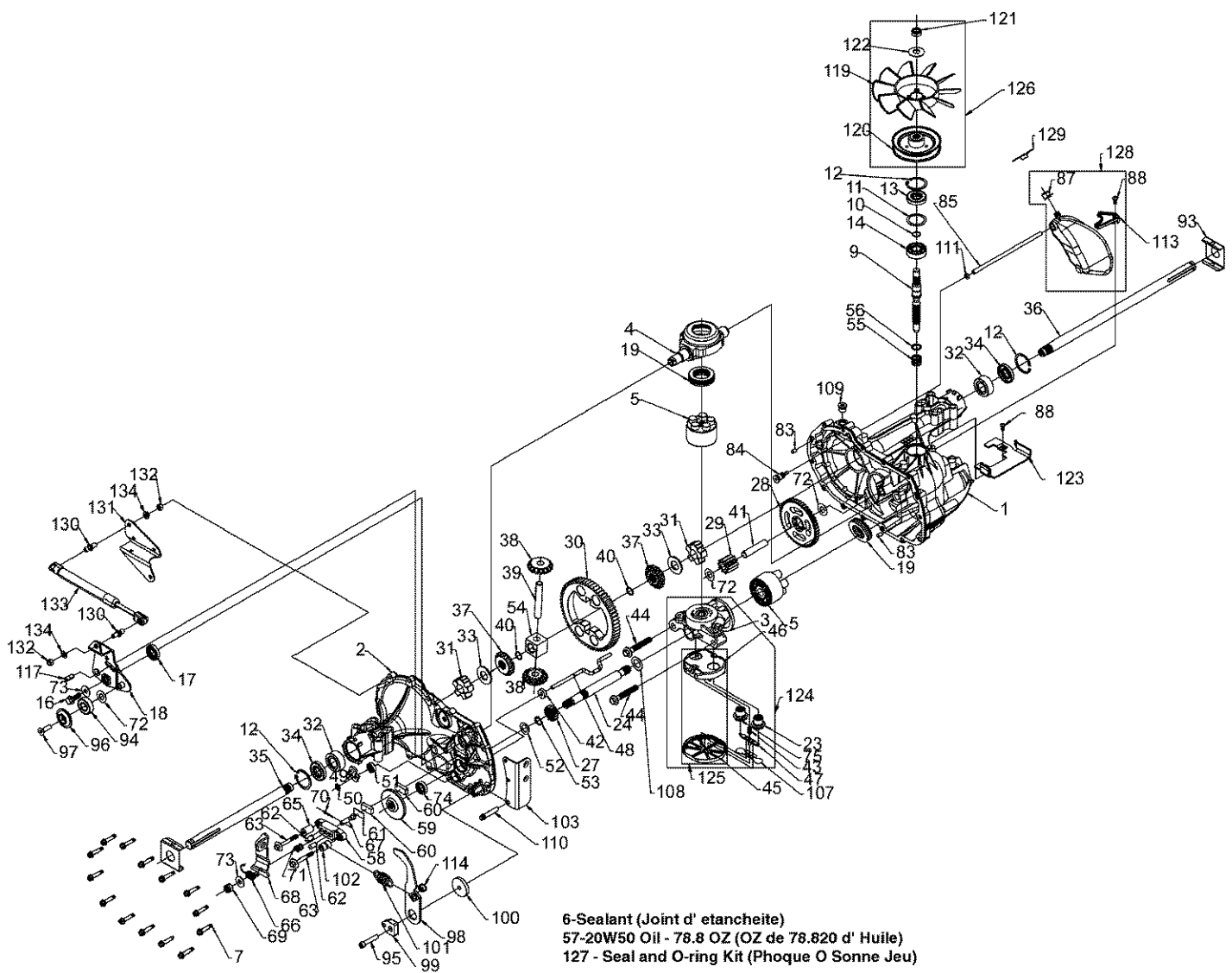

TRACTOR - - MODEL NUMBER 917.273281
HYDRO GEAR TRANSAXLE - - MODEL NUMBER 336-0510

| KEY NO. | PART NO. | DESCRIPTION | KEY NO. | PART NO. | DESCRIPTION |
|---------|----------|---|---------|----------|--|
| 1 | 170351 | Main Housing, Assembly | 68 | 178782 | Arm, Brake |
| 2 | 170352 | Side Housing, Assembly | 69 | 170415 | Slotted Hex Nut 5/16-24 |
| 3 | 170353 | Center Section, Assembly | 70 | 170416 | Cotter Pin 3/32 X 3/4 |
| 4 | 170354 | Swashplate, Trunion Machined | 71 | 170417 | Compression Spring Brake Anti- Drag |
| 5 | 169898 | Block - Assembly | | | |
| 6 | 170355 | Sealant 10.5 Oz | 72 | 170418 | Washer, Ht .5 I.D. X 1 O.D. X .032 |
| 7 | 170356 | Hex Flange Screw 1/4-20 X 1.25 | | | |
| 8 | 170357 | Stud, 5/16-24 Hex Double End | 73 | 142884 | Flat - Washer 11/32 I.D. X 7/8O.D |
| 9 | 170358 | Shaft, Input | 74 | 170419 | Oil Seal .625 X 1.0 X .25 |
| 10 | 170359 | Ring - Retaining | 75 | 170420 | Check Plug Assembly, .027, Washer |
| 11 | 170360 | Spacer | | | |
| 12 | 169870 | Ring - Retaining | 76 | 170421 | Stud, 5/16-24 Friction Pack |
| 13 | 170361 | Seal, Lip .67 X 1.58 X .276 | 77 | 170422 | Puck, .330 X 1.50 X .0975 |
| 14 | 169869 | Ball Brg 17mm Id X 40mm Od X 12mm | 78 | 142969 | Spring, Helical Comp |
| | | | 79 | 142980 | Spacer |
| 16 | 170362 | Hex Flange Head Screw 5/16- 24X0.75 | 80 | 150778 | Hex Lock Nut 5/16-24Unjf(Nylon Insert) |
| 17 | 170363 | Lip Seal 18 X 32 X 7 | 81 | 170423 | Wedge, Friction Pack |
| 18 | 178781 | Arm, Control | 82 | 170424 | Clip, Washer .316x1.50x.1046 (Plated) |
| 19 | 150771 | Bearing, 30x52x13 Thrust | | | |
| 23 | 170365 | Check Plug Assembly, Washer | 83 | 161168 | Pin, Standard Headless |
| 24 | 170366 | Shaft, Motor | 84 | 170425 | Fitting, 5/16 Sae 5/32 Tube |
| 27 | 170367 | Gear - Pinion, 13t | 85 | 170426 | Hose, Expansion Tank |
| 28 | 170368 | 10t/48t Gear | 87 | 142917 | Cap - Poppet Valve |
| 29 | 170369 | Gear, 10t Jackshaft | 88 | 170429 | Bolt, Self Tapping 10-32 X 1/2 |
| 30 | 170370 | 60t Bull Gear | 90 | 170430 | Puck, Inner Wedge |
| 31 | 170371 | Sleeve Bearing .75 X 1.575 X .625 | 93 | 170431 | Spring Clip - Housing Thrust |
| 32 | 170389 | SleeveBearing(Outboard) .75x1.750x.625 | 94 | 178783 | Bearing, Ball |
| | | | 95 | 178784 | Screw, Socket Head Cap 5/16- 24X1-1/2 |
| 33 | 142991 | Washer, 3/4 Id X 1-1/2 Od X .13 Thk | 96 | 178786 | Spacer, Locating |
| 34 | 170390 | Lip Seal Axle Seal | 97 | 178787 | Screw, SFHCS 5/16-18 X1 |
| 35 | 170391 | Shaft, Axle .75 X 11.39 (Key, R.H.) | 98 | 178789 | Arm Return |
| 36 | 170392 | Shaft, Axle .75 X 16.99 (Key, L.H.) | 99 | 178792 | Puck, Adjusting |
| 37 | 150792 | Miter Gear (Splined) | 100 | 178793 | Washer, .24 ID X 1.60 OD X .239 |
| 38 | 150793 | Miter Gear 15t (0.5 Id) | 101 | 178794 | Spring, Extension |
| 39 | 150809 | Shaft | 102 | 178795 | Spacer .260 ID X .560 OD X .870 |
| 40 | 170393 | Ring, Spiral Retaining | 103 | 178796 | Bracket, Torque |
| 41 | 170394 | Pin, Jackshaft | 107 | 170432 | Deflector |
| 42 | 170395 | Magnet, Ring | 108 | 170433 | Washer, Motor Shaft .71idx1.15od x.030thk |
| 43 | 170396 | Spring, Bypass | | | |
| 44 | 150797 | Hydro Mtg Screw 3/8-24 X 2.5 Long | 109 | 170434 | Plug, Sae #6 |
| | | | 111 | 170435 | O-Ring .07 X .301 I.D. |
| 45 | 170397 | Filter | 113 | 170437 | Bracket, Support Expansion Tank |
| 46 | 170398 | Base, Filter | 114 | 178797 | Spring |
| 47 | 170399 | Actuator, Bypass | 116 | 170438 | Silicon Sponge |
| 48 | 170400 | Rod, Bypass Actuator | 117 | 178799 | Pin, Spring |
| 49 | 170401 | Arm, Bypass | 119 | 170439 | Fan, 7 In. |
| 50 | 170402 | Retaining Ring .250 External | 120 | 170440 | Pulley |
| 51 | 170403 | Seal, Lip .741 X .250 X .250 Tc | 121 | 170441 | Hex Lock Nut 1/2-20 (Nylon Insert) |
| 52 | 170404 | Flat Washer, 5/8 Id X 1.0 Od X .05 Thk | 122 | 170442 | Washer, Belleville |
| 53 | 170405 | Retaining Ring | 123 | 178800 | Belt Keeper |
| 54 | 170406 | Bearing, Center Block | 124 | 170444 | Center Section-Filter-Bypass Assembly |
| 55 | 142977 | Spring - Helical Compression | | | |
| 56 | 142978 | Washer | 125 | 170445 | Filter Assembly |
| 57 | 150798 | 20w-50 Oil | 126 | 170446 | Fan - Pulley Service Assembly |
| 58 | 170407 | Brake Yoke | 127 | 170447 | Seal - O-Ring Kit |
| 59 | 170408 | Rotor, Brake | 128 | 173165 | Kit, Expansion Tank |
| 60 | 142883 | Brake Puck | 130 | 178802 | Stud Ball |
| 61 | 142882 | Puck Plate | 131 | 178803 | Bracket, Cruise Damper |
| 62 | 142887 | Brake Actuating Pin | 132 | 178804 | Hex Nut 5/16-18 NC |
| 63 | 170410 | Hfhcs 1/4-20x2 W/Patch, SpecialFlange | 133 | 184227 | Damper |
| | | | 134 | 178808 | Washer, Helical Spring Lock 5/16 |
| 64 | 142892 | Bolt, 1/4-20 X 1 W/Patch | 900 | 173839 | Transaxle Complete |
| 65 | 170411 | Spacer | | | |
| 66 | 170412 | Spring, Brake Arm Bias | | | |
| 67 | 170413 | Sq. Hd. Bolt 5/16-24-Ribbed | | | |

NOTE: All component dimensions given in U.S. inches
1 inch = 25.4 mm

**TRACTOR - - MODEL NUMBER 917.273281
BRIGGS ENGINE-MODEL NUMBER 407777 TYPE NUMBER 0121-E4**

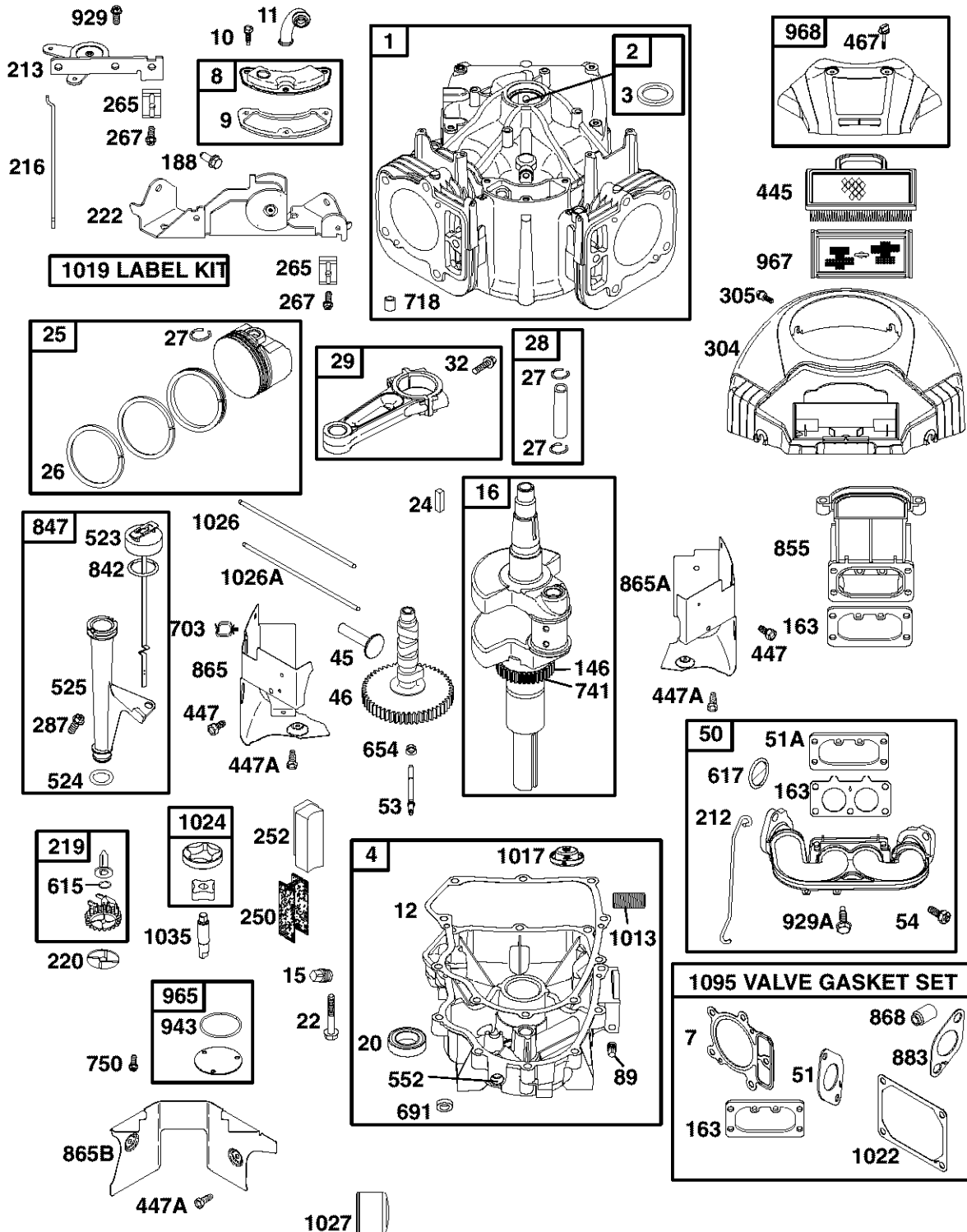

**TRACTOR - - MODEL NUMBER 917.273281
BRIGGS ENGINE-MODEL NUMBER 407777 TYPE NUMBER 0121-E4**

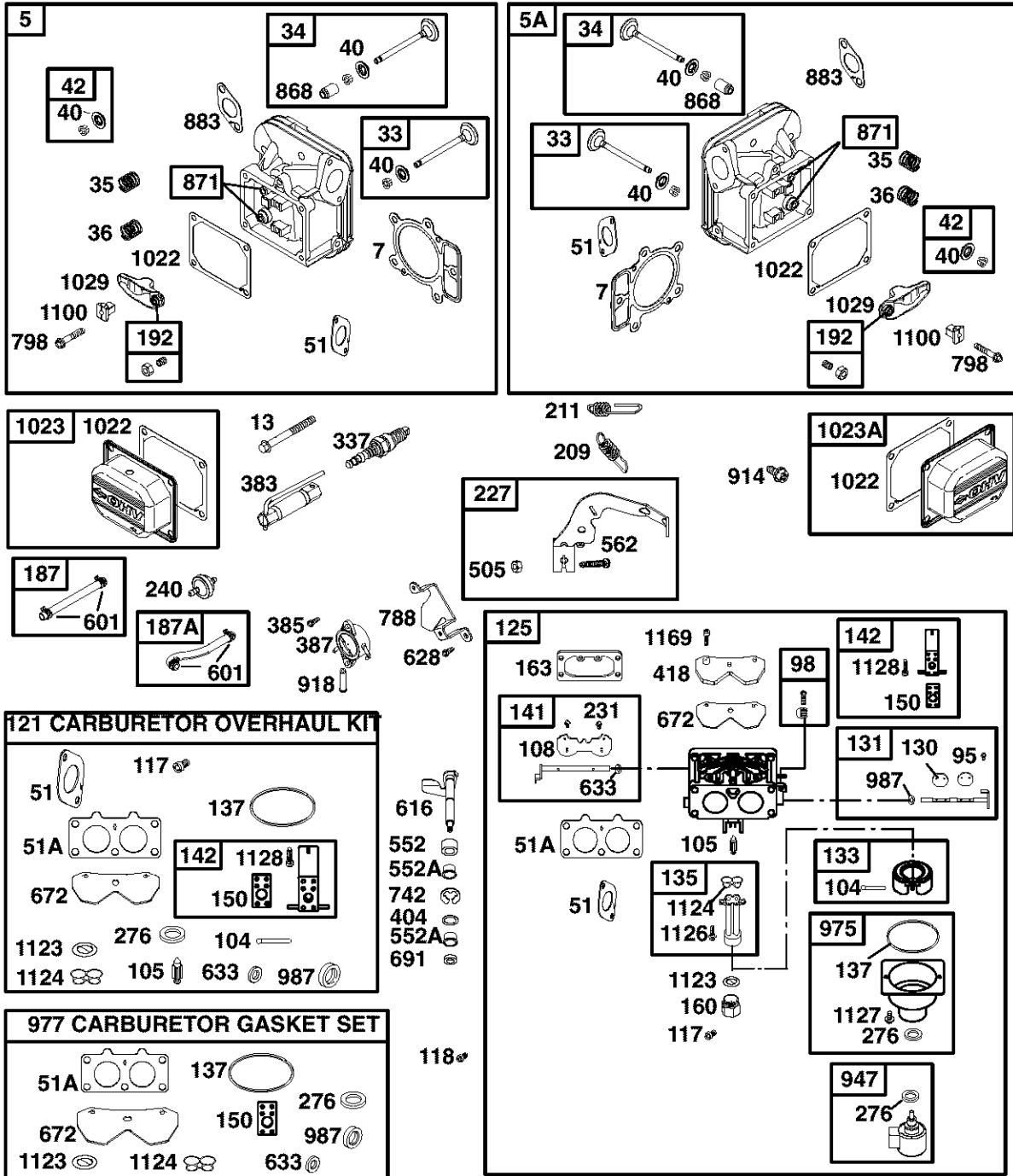

**TRACTOR - - MODEL NUMBER 917.273281
BRIGGS ENGINE-MODEL NUMBER 407777 TYPE NUMBER 0121-E4**

1058 OWNER'S MANUAL

1036 EMISSIONS LABEL

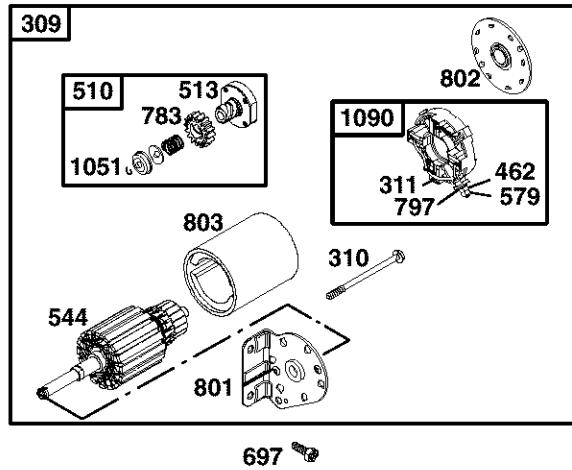
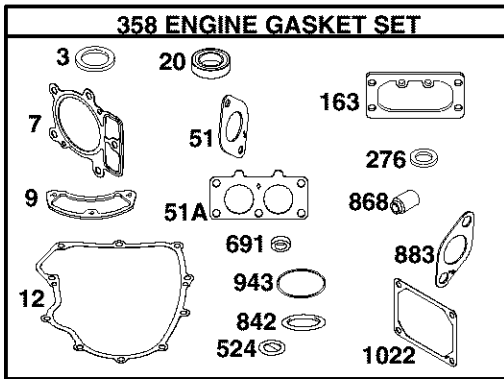
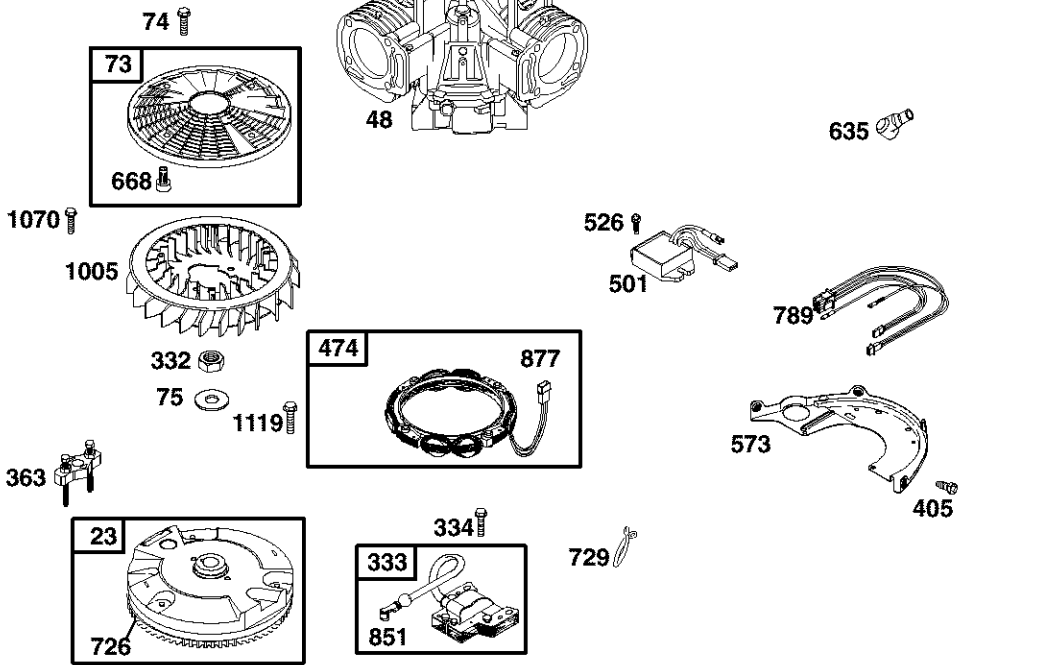

TRACTOR - - MODEL NUMBER 917.273281
BRIGGS ENGINE-MODEL NUMBER 407777 TYPE NUMBER 0121-E4

| KEY NO. | PART NO. | DESCRIPTION | KEY NO. | PART NO. | DESCRIPTION |
|---------|----------|--|---|----------|------------------------------------|
| 1 | 690231 | Cylinder Assembly | 131 | 499805 | Throttle Shaft Kit |
| 2 | 499585 | Bushing-Cylinder | 133 | 499806 | Float-Carburetor |
| 3 | 391086 | •Seal-Oil | 135 | 499803 | Fuel Transfer Tube |
| 4 | 690069 | Sump-Engine | 137 | 690994 | Ø ‡ Gasket-Float Bowl |
| 5 | 693998 | Head-Cylinder No. 1 | 141 | 499807 | Choke Shaft Kit |
| 5A | 693999 | Head-Cylinder No. 2 | 142 | 499808 | Ø Nozzle-Carburetor |
| 7 | 690962 | •+ Gasket-Cylinder Head | 146 | 690979 | Key-Timing |
| 8 | 499601 | Breather Assembly | 150 | 690995 | Ø ‡ Gasket-Nozzle |
| 9 | 690937 | • Gasket-Breather | 160 | 690996 | Retainer-Solenoid |
| 10 | 690960 | Screw (Breather Assy.) | 163 | 691001 | •+ Gasket-Air Cleaner |
| 11 | 690942 | Tube-Breather | 187 | 691050 | Line-Fuel (Cut to Required Length) |
| 12 | 690945 | • Gasket-Crankcase | 187A | 691049 | Line-Fuel |
| 13 | 690360 | Screw (Cylinder Head) | 188 | 690960 | Screw (Control Bracket) |
| 15 | 691680 | Plug-Oil Drain | 192 | 690083 | Adjuster-Rocker Arm |
| 16 | 691046 | Crankshaft | 209 | 697674 | Spring-Governor |
| 20 | 690947 | • Seal-Oil (PTO Side) | 211 | 691019 | Spring-Governed Idle |
| 22 | 694966 | Screw (Engine Sump) | 212 | 695238 | Link-Throttle |
| 23 | 691053 | Flywheel | 213 | 691021 | Bracket-Choke Control |
| 24 | 222698 | Key-Flywheel | 216 | 691022 | Link-Choke |
| 25 | 499588 | Piston Assembly (Std.) | 219 | 698231 | Gear-Governor |
| 25 | 499589 | Piston Assembly (.010 O.S.) | 220 | 690412 | Washer (Governor Lever) |
| 25 | 499590 | Piston Assembly (.020 O.S.) | 222 | 698761 | Bracket-Control |
| 25 | 499591 | Piston Assembly (.030 O.S.) | 227 | 691048 | Control Lever-Governor |
| 26 | 499604 | Ring Set-Piston (Std.) | 231 | 690718 | Screw (Choke Valve) |
| 26 | 499605 | Ring Set-Piston (.010 O.S.) | 240 | 691035 | Filter-Fuel |
| 26 | 499606 | Ring Set-Piston (.020 O.S.) | 250 | 690957 | Retainer-Breather |
| 26 | 499607 | Ring Set-Piston (.030 O.S.) | 252 | 690956 | Element-Breather |
| 27 | 690975 | Lock-Piston Pin | 265 | 691024 | Clamp-Casing |
| 28 | 690229 | Pin-Piston | 267 | 695134 | Screw (Casing Clamp) |
| 29 | 499583 | Rod-Connecting | 276 | 690997 | • Ø ‡ Sealing Washer |
| 32 | 690976 | Screw (Connecting Rod) | 287 | 690960 | Screw (Dipstick Tube) |
| 33 | 499596 | Valve-Exhaust | 304 | 695277 | Housing-Blower |
| 34 | 499597 | Valve-Intake | 305 | 691005 | Screw (Blower Housing) |
| 35 | 690963 | Spring-Valve (Intake) | 309 | 691262 | Motor-Starter |
| 36 | 690963 | Spring-Valve (Exhaust) | 310 | 691263 | Bolt-Starter Motor |
| 40 | 690964 | Retainer-Valve | 311 | 497608 | Brush Set |
| 42 | 499586 | Keeper-Valve | 332 | 691059 | Nut (Flywheel) |
| 45 | 690977 | Valve Tappet | 333 | 691060 | Armature-Magneto |
| 46 | 690978 | Cam Shaft | 334 | 691061 | Screw (Magneto Armature) |
| 48 | 692714 | Short Block(Replacement Engine 445777-0027-E2) | 337 | 691043 | Spark Plug |
| 50 | 695241 | Manifold-Intake | 358 | 499889 | Gasket Set |
| 51 | 690949 | • Ø + Gasket-Intake | 363 | 691062 | Flywheel Puller |
| 51A | 690950 | • Ø ‡ Gasket-Intake | 383 | 690966 | Wrench-Spark Plug |
| 53 | 690951 | Stud (Carburetor) | 385 | 690960 | Screw (Fuel Pump) |
| 54 | 695240 | Screw (Intake Manifold) | 387 | 808656 | Pump-Fuel |
| 73 | 691055 | Screen-Rotating | 404 | 690442 | Washer (Governor Crank) |
| 74 | 691057 | Screw (Rotating Screen) | 405 | 697820 | Screw (Back Plate) |
| 75 | 691056 | Washer (Flywheel) | RPM Settings: | | Low Speed: 1900-2100 |
| 89 | 690283 | Plug-Oil | | | High Speed: 3000-3200 |
| 95 | 690718 | Screw (Throttle Valve) | • Included in Engine Gasket Set, Key. No. 358 | | |
| 98 | 499802 | Idle Speed Kit | Ø Included in Carburetor Overhaul Kit, Key. No. 121 | | |
| 104 | 690984 | Ø Pin-Float Hinge | ‡ Included in Carburetor Gasket Set, Key. No. 977 | | |
| 105 | 690985 | Ø Valve-Float Needle | + Included in Valve Gasket Set, Key. No. 1095 | | |
| 108 | 690986 | Valve-Choke | | | |
| 117 | 690232 | Ø Jet-Main (Standard) | | | |
| 118 | 690989 | Jet-Main (High Altitude) | | | |
| 121 | 499811 | Carburetor Overhaul Kit | | | |
| 125 | 499804 | Carburetor | | | |
| 130 | 690993 | Valve-Throttle | | | |

NOTE: All component dimensions given in U.S. inches 1 inch = 25.4 mm

**TRACTOR - - MODEL NUMBER 917.273281
BRIGGS ENGINE-MODEL NUMBER 407777 TYPE NUMBER 0121-E4**

| KEY NO. | PART NO. | DESCRIPTION | KEY NO. | PART NO. | DESCRIPTION |
|---------|----------|--|---------|----------|---|
| 418 | 690999 | Plate-Cover | 865B | 691015 | Cover-Air Guide |
| 445 | 499486 | Filter-Air Cleaner Cartridge | 868 | 690968 | •+ Seal-Valve |
| 447 | 691003 | Screw (Air Guide Cover) | 871 | 690969 | Bushing-Guide |
| 447A | 690960 | Screw (Air Guide Cover) | 877 | 399916 | Alternator Connector/Wire |
| 462 | 691261 | Washer (Starter Cable) | 883 | 690970 | •+ Gasket-Exhaust |
| 467 | 691008 | Knob-Air Cleaner | 914 | 691127 | Screw (Rocker Cover) |
| 474 | 696458 | Alternator | 918 | 694000 | Hose-Vacuum |
| 501 | 691185 | Regulator | 929 | 691003 | Screw (Choke Control Bracket) |
| 505 | 691029 | Nut (Gov. Control Lever) | 929A | 695239 | Screw (Choke Control Bracket) |
| 510 | 497606 | Drive-Starter | 943 | 690589 | • O-Ring Seal (Oil Pump Cover) |
| 513 | 692024 | Clutch-Drive | 947 | 499809 | Solenoid-Fuel |
| 523 | 691036 | Dipstick | 965 | 499613 | Oil Pump Cover |
| 524 | 691032 | • Dipstick Tube Seal | 967 | 273638 | Filter-Pre-Cleaner |
| 525 | 691037 | Dipstick Tube | 968 | 499788 | Cover-Air Cleaner |
| 526 | 690960 | Screw (Regulator) | 975 | 499810 | Bowl-Float |
| 544 | ----- | Armature-Starter (Service with 691262 Starter Motor) | 977 | 499812 | Gasket Set-Carburetor |
| | | | 987 | 691000 | Ø ‡ Seal-Throttle Shaft |
| 552 | 690552 | Bushing-Governor Crank | 1005 | 691243 | Fan-Flywheel |
| 552A | 690553 | Bushing-Governor Crank | 1013 | 690954 | Nipple-Oil Filter |
| 562 | 690311 | Bolt (Gov. Control Lever) | 1017 | 690770 | Oil Pump Screen |
| 573 | 691009 | Plate-Back | 1019 | 690103 | Label Kit |
| 579 | 691029 | Nut (Starter Cable) | 1022 | 690971 | •+ Gasket-Rocker Cover |
| 601 | 691038 | Clamp-Hose | 1023 | 499599 | Cover-Rocker (Cylinder No. 1) |
| 615 | 698290 | Retainer-Governor Shaft | 1023A | 499600 | Cover-Rocker (Cylinder No. 2) |
| 616 | 691045 | Crank-Governor | 1024 | 499054 | Pump-Oil |
| 617 | 697891 | Seal-O Ring | 1026 | 690981 | Rod-Push (Steel) |
| 628 | 690960 | Screw (Fuel Pump Bracket) | 1026A | 690982 | Rod-Push (Aluminum) |
| 633 | 690998 | Ø ‡ Seal-Choke Shaft | 1027 | 492932 | Filter-Oil |
| 635 | 66538 | Boot-Spark Plug | 1029 | 690972 | Rocker Arm |
| 654 | 690958 | Nut (Carburetor) | 1035 | 691042 | Shaft-Pump |
| 668 | 691215 | Spacer | 1036 | 695704 | Emission Label |
| 672 | 690234 | Ø ‡ Gasket-Carburetor Plate | 1051 | 691265 | Ring-Retaining |
| 691 | 690657 | • Governor Shaft Seal | 1058 | 275475 | Owner's Manual |
| 697 | 690372 | Screw (Drive Cap) | 1070 | 691058 | Screw (Flywheel Fan) |
| 703 | 691010 | Clip | 1090 | 691293 | Retainer-Brush |
| 718 | 690959 | Pin-Locating | 1095 | 499890 | Valve Gasket Set |
| 726 | 499612 | Gear-Ring | 1100 | 690973 | Rocker Arm Pivot |
| 729 | 694123 | Wire Clip | 1119 | 691183 | Screw (Alternator) |
| 741 | 690980 | Gear-Timing | 1123 | 690987 | Ø ‡ O-Ring Seal (Solenoid Retainer) |
| 742 | 690328 | E-Ring Retainer | 1124 | 690988 | Ø ‡ O-Ring Seal-Fuel Transfer Tube |
| 750 | 696999 | Screw (Oil Pump Cover) | 1126 | 690991 | Screw (Fuel Transfer Tube) |
| 783 | 693058 | Gear-Pinion | 1127 | 690992 | Screw (Float Bowl) |
| 788 | 691039 | Fuel Pump Bracket | 1128 | 690990 | Ø Screw (Carburetor Nozzle) |
| 789 | 695050 | Harness-Wiring | 1169 | 693140 | Screw (Carburetor Cover Plate) |
| 797 | 698330 | Screw (Brush Retainer) | | | RPM Settings: Low Speed: 1900-2100 |
| 798 | 690967 | Screw (Rocker Arm) | | | High Speed: 3000-3200 |
| 801 | 691283 | Cap-Drive | | | |
| 802 | 691286 | Cap-End | | | |
| 803 | ----- | Starter Housing (Service with 691262 Starter Motor) | • | | Included in Engine Gasket Set, Key. No. 358 |
| | | | Ø | | Included in Carburetor Overhaul Kit, Key. No. 121 |
| 842 | 691031 | • Dipstick/Tube Seal | ‡ | | Included in Carburetor Gasket Set, Key. No. 977 |
| 847 | 499602 | Dipstick/Tube Assembly | + | | Included in Valve Gasket Set, Key. No. 1095 |
| 851 | 493880 | Terminal-Spark Plug | | | |
| 855 | 691011 | Adapter-Air | | | |
| 865 | 691012 | Cover-Air Guide | | | |
| 865A | 691014 | Cover-Air Guide | | | |

NOTE: All component dimensions given in U.S. inches 1 inch = 25.4 mm

SUGGESTED GUIDE FOR SIGHTING SLOPES FOR SAFE OPERATION

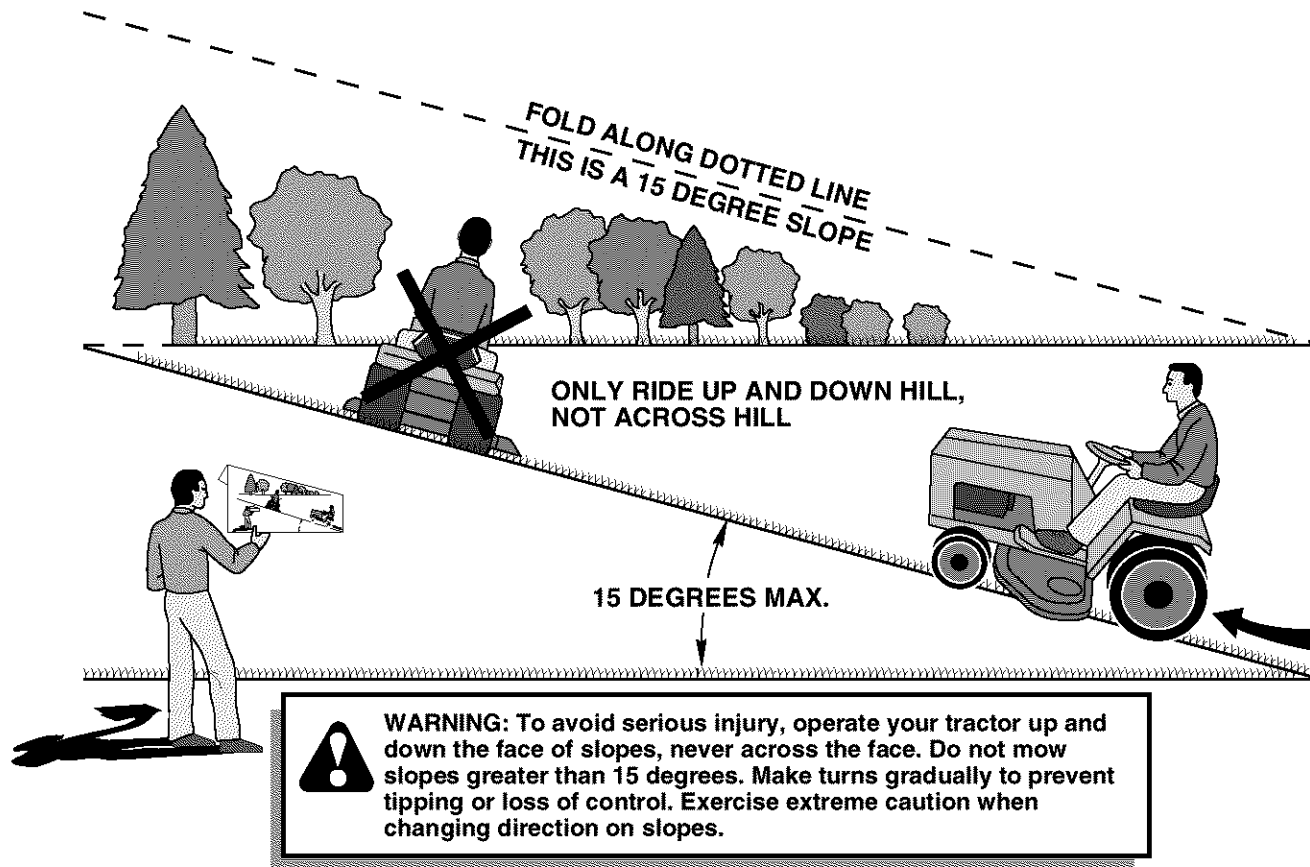

1. Fold this page along dotted line indicated above.
2. Hold page before you so that its left edge is vertically parallel to a tree trunk or other upright structure.
3. Sight across the fold in the direction of hill slope you want to measure.
4. Compare the angle of the fold with the slope of the hill.

Get it fixed, at your home or ours!

Your Home

For repair – **in your home** – of **all** major brand appliances, lawn and garden equipment, or heating and cooling systems, **no matter who made it, no matter who sold it!**

For the replacement parts, accessories and owner's manuals that you need to do-it-yourself.

For Sears professional installation of home appliances and items like garage door openers and water heaters.

1-800-4-MY-HOME[®] Anytime, day or night
(1-800-469-4663) (U.S.A. and Canada)
www.sears.com **www.sears.ca**

Our Home

For repair of carry-in products like vacuums, lawn equipment, and electronics, call or go on-line for the nearest **Sears Parts and Repair Center.**

1-800-488-1222 Anytime, day or night (U.S.A. only)
www.sears.com

To purchase a protection agreement (U.S.A.) or maintenance agreement (Canada) on a product serviced by Sears:

1-800-827-6655 (U.S.A.) **1-800-361-6665** (Canada)

Para pedir servicio de reparación a domicilio, y para ordenar piezas:

1-888-SU-HOGARSM
(1-888-784-6427)

Au Canada pour service en français:

1-800-LE-FOYER^{MC}
(1-800-533-6937)
www.sears.ca

SEARS

© Sears, Roebuck and Co

® Registered Trademark / TM Trademark / SM Service Mark of Sears, Roebuck and Co

® Marca Registrada / TM Marca de Fábrica / SM Marca de Servicio de Sears, Roebuck and Co

^{MC} Marque de commerce / ^{MD} Marque déposée de Sears, Roebuck and Co