

# *Lifestyler*<sup>®</sup> *expans e 600*

## SEARS

Model No. 831.297161

Serial No. \_\_\_\_\_

The serial number is found in the location shown below. Write the serial number in the space above for future reference.

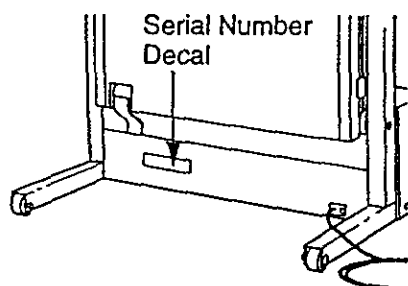

EXERCISE  
EQUIPMENT

**QUESTIONS**

HELPLINE!

1-800-736-6879

## USER'S MANUAL

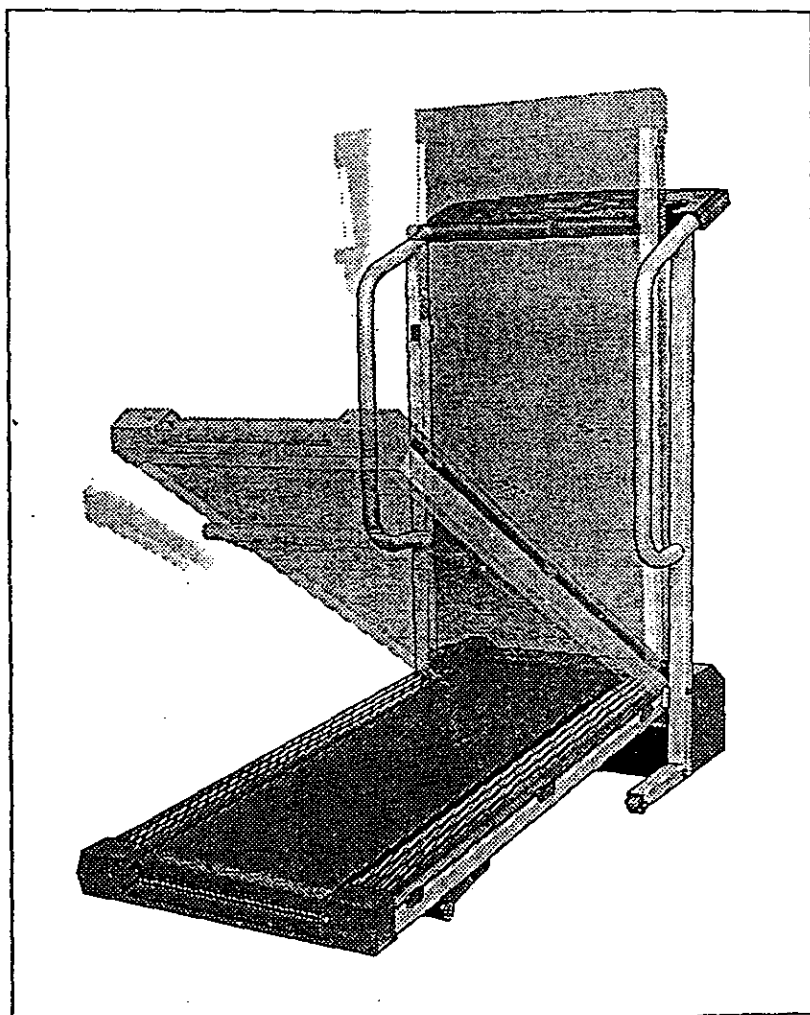

### **CAUTION**

Read all precautions and instructions in this manual before using this equipment. Save this manual for future reference.

# BEFORE YOU BEGIN

Thank you for selecting the LIFESTYLER® EXPANSE 600 treadmill. The EXPANSE 600 treadmill combines advanced technology with innovative design to let you enjoy an excellent form of cardiovascular exercise in the convenience and privacy of your home. And when you're not exercising, the unique EXPANSE 600 can be folded up, requiring less than half the floor space of other treadmills.



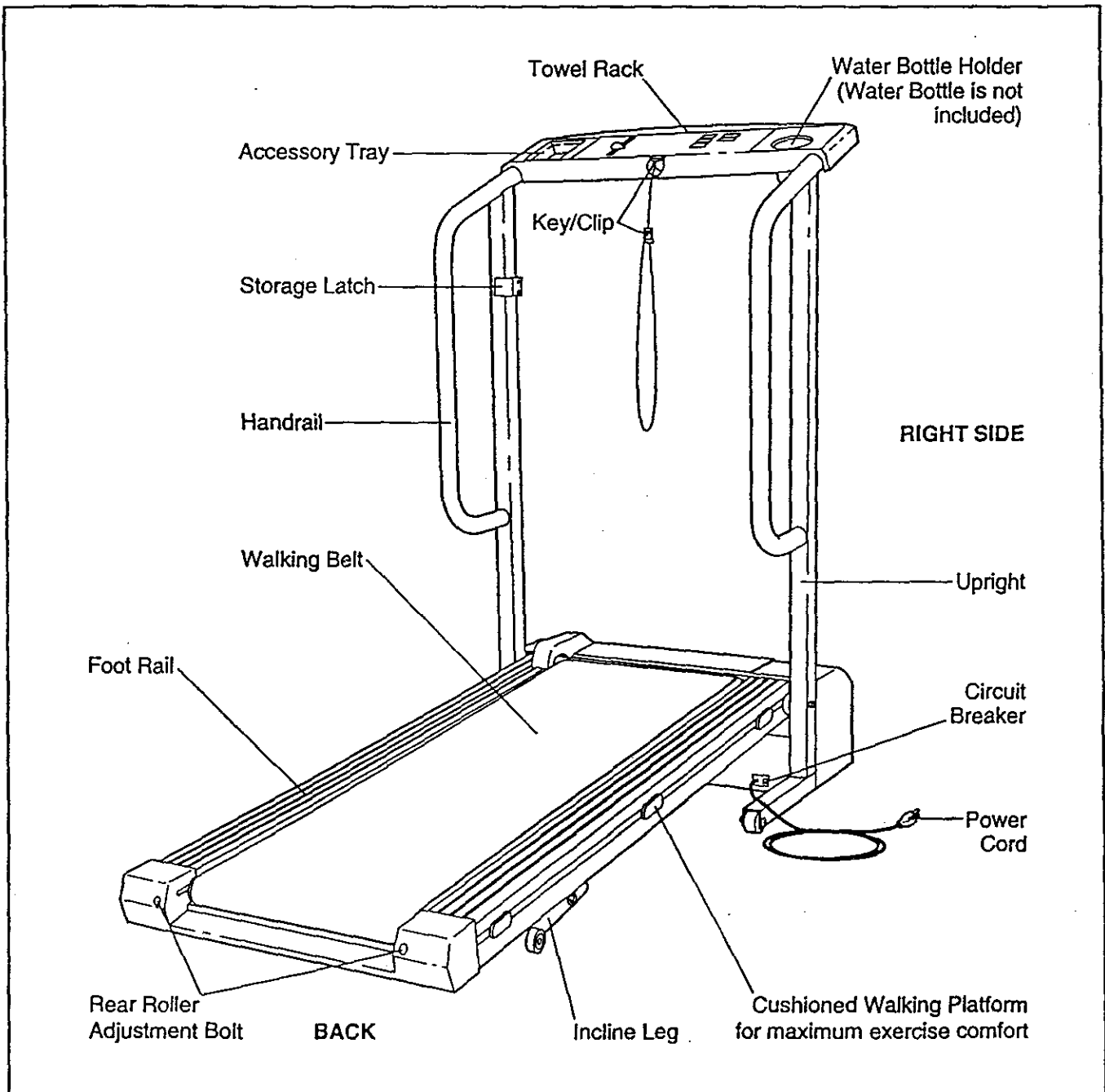

For your benefit, read this manual carefully before using the treadmill. If you have additional questions, please call our toll-free HELPLINE at 1-800-736-6879,

Monday through Saturday, 7 a.m. until 7 p.m. Central Time (excluding holidays). To help us assist you, please note the product model number and serial number before calling. The model number of the treadmill is 831.297161. The serial number can be found on a decal attached to the treadmill (see the front cover of this manual for the location).

Before reading further, please review the drawing below and familiarize yourself with the parts that are labeled.

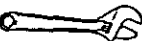
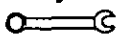

# ASSEMBLY

Assembly requires two people. Set the treadmill in a cleared area and remove all packing materials. Do not dispose of the packing materials until assembly is completed. Refer to the drawings below to identify the small parts used in assembly. Assembly requires the included allen wrench  and your own phillips screwdriver , adjustable wrench , open end wrench  and scissors .

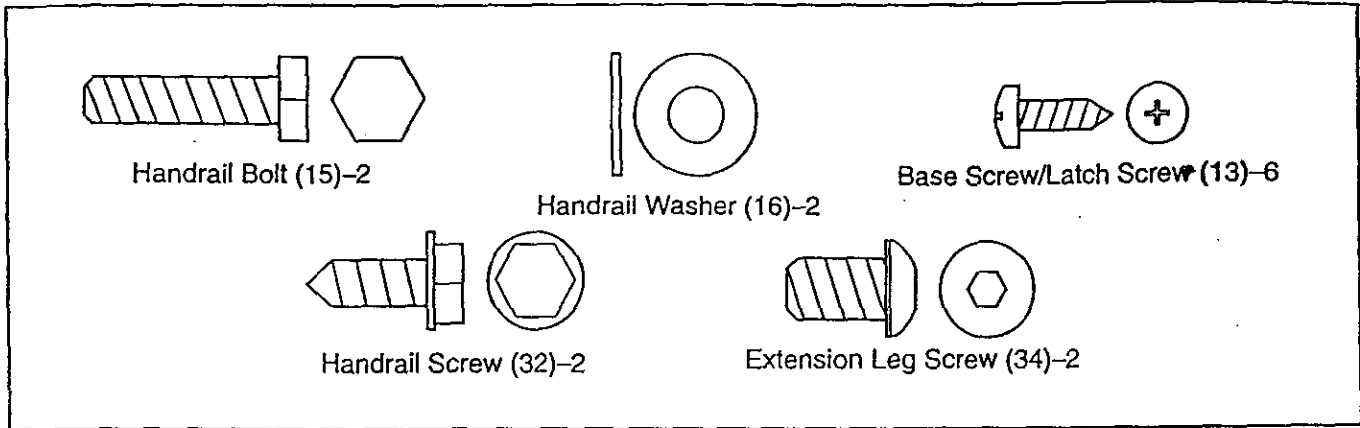

1. With the help of a second person, carefully lay the treadmill on its right side. Insert one of the Extension Legs (41) into the treadmill as shown. Make sure that the Base Pad (36) is on the bottom of the Extension Leg. Attach the Extension Leg with an Extension Leg Screw (34). Be sure to push on the head of the Extension Leg Screw while tightening it.

Attach the other Extension Leg (41) as described above.

With the help of a second person, carefully raise the treadmill to the upright position so the Extension Legs (41) are resting flat on the floor.

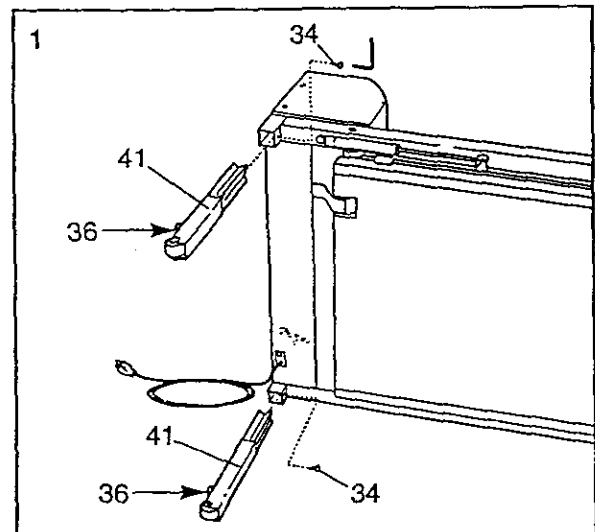

2. Refer to HOW TO LOWER THE TREADMILL FOR USE on page 11. Follow the instructions in step 2 to lower the treadmill.

Refer to the inset drawing. Remove the nut, bolt, and shipping bracket from the left Upright (14).

Position one of the Handrails (2) on the left Upright (14) as shown. Thread a Handrail Bolt (15) with a Handrail Washer (16) into the left Upright and the Handrail. Do not tighten the Handrail Bolt yet. Tighten a Handrail Screw (32) into the lower end of the Handrail. Be sure to push on the head of the Handrail Screw while tightening it. Next, tighten the Handrail Bolt (15).

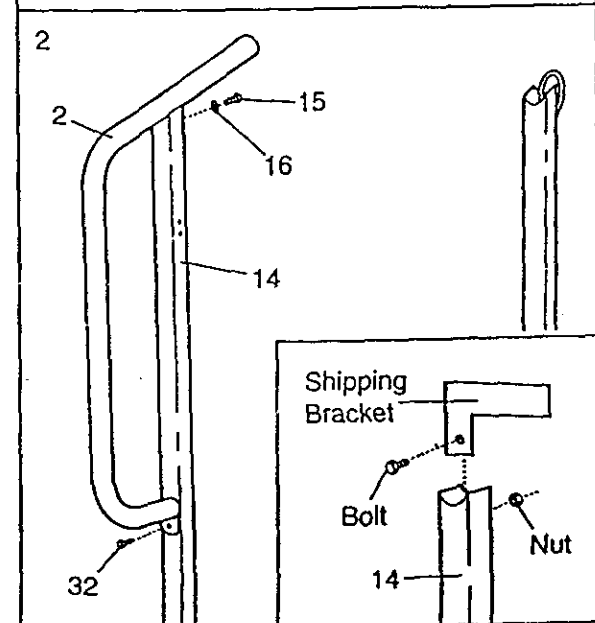

3. With the help of a second person, hold the Console Base (6) and the other Handrail (2) near the right Upright (14) as shown. Note: It may be helpful to rest the other side of the Console Base on the left Handrail.

Connect the Console Wire Harness (88) to the two plugs on the Upright Wire Harness (26). Refer to the upper inset drawing. Locate the 7 1/2" Wire Ties (10) on the Console Wire Harness (88) and the Upright Wire Harness (26). Slide the Wire Ties against the plugs as shown. Insert the 11 1/2" Wire Tie (55) through the holes in the Wire Ties. Close and tighten the 11 1/2" Wire Tie.

Refer to the lower inset drawing. Insert the Wire Harnesses (26, 88) into the Right Upright (14). Note: If necessary, bend the Wire Harnesses into an "s" shape.

Route the Console Wire Harness (88) through the notch in the bracket on the right Handrail (2) as shown. Insert the bracket into the right Upright (14). Make sure that the Console Wire Harness is not pinched.

4. Thread a Handrail Bolt (15) with a Handrail Washer (16) into the right Upright (14) and the right Handrail (2). Do not tighten the Handrail Bolt yet. Tighten a Handrail Screw (32) into the lower end of the Handrail. Be sure to push on the head of the Handrail Screw while tightening it. Next, tighten the Handrail Bolt (15).

Place the Console Base (6) on the left and right Handrails (2). Attach the Console Base with four Console Screws (13).

5. Attach the Storage Latch (12) to the left Upright (14) with two Latch Screws (13). Be careful not to overtighten the Latch Screws.

6. Remove the backing from the Adhesive Clip (74). Press the Adhesive Clip onto the Upright Base (14) in the indicated location. Press the Allen Wrench (73) into the Adhesive Clip.

7. Make sure that all parts are tightened before you use the treadmill. Note: To protect the floor or carpet, place a mat under the treadmill.

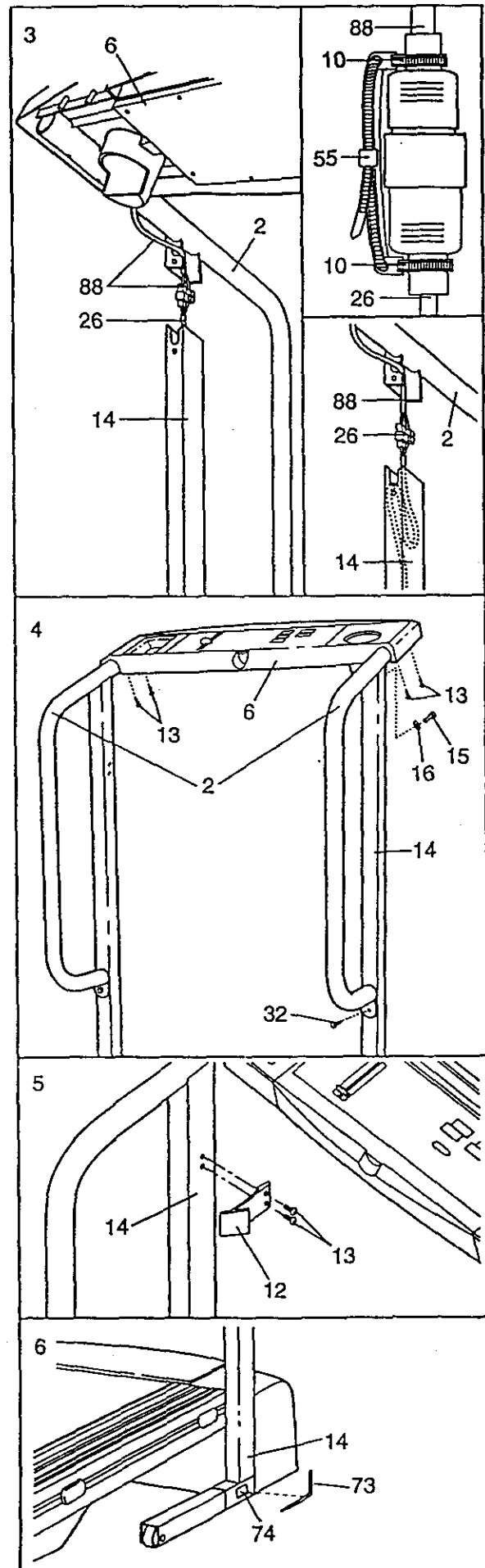

# OPERATION AND ADJUSTMENT

## THE PERFORMANT LUBE™ WALKING BELT

Your treadmill features a walking belt coated with PERFORMANT LUBE™, a high-performance lubricant. **IMPORTANT:** Never apply silicone spray or other substances to the walking belt or the walking platform. Such substances will deteriorate the walking belt and cause excessive wear.

## HOW TO PLUG IN THE POWER CORD

**⚠ DANGER:** Improper connection of the equipment-grounding conductor can result in an increased risk of electric shock. Check with a qualified electrician or serviceman if you are in doubt as to whether the product is properly grounded. Do not modify the plug provided with the product—if it will not fit the outlet, have a proper outlet installed by a qualified electrician.

Your treadmill, like any other type of sophisticated electronic equipment, can be seriously damaged by sudden voltage changes in your home's power. Voltage surges, spikes, and noise interference can result from weather conditions or from other appliances being turned on or off. To decrease the possibility of your treadmill being damaged, always use a surge suppressor with your treadmill (see drawing 1 at the right).

Surge suppressors are sold at most hardware stores and department stores. Use only a single-outlet surge suppressor that is UL 1449 listed as a transient voltage surge suppressor (TVSS). The surge suppressor must have a UL suppressed voltage rating of 400 volts or less and a minimum surge dissipation of 450 joules. The surge suppressor must be electrically rated for 120 volts AC and 15 amps.

This product must be grounded. If it should malfunction or break down, grounding provides a path of least resistance for electric current to reduce the risk of electric shock. This product is equipped with a cord having an equipment-grounding conductor and a grounding plug. Plug the power cord into a surge suppressor, and plug the surge suppressor into an appropriate outlet that is properly installed and grounded in accordance with all local codes and ordinances.

This product is for use on a nominal 120-volt circuit, and has a grounding plug that looks like the plug illustrated in drawing 1 below. A temporary adapter that looks like the adapter illustrated in drawing 2 may be used to connect the surge suppressor to a 2-pole receptacle as shown in drawing 2 if a properly grounded outlet is not available.

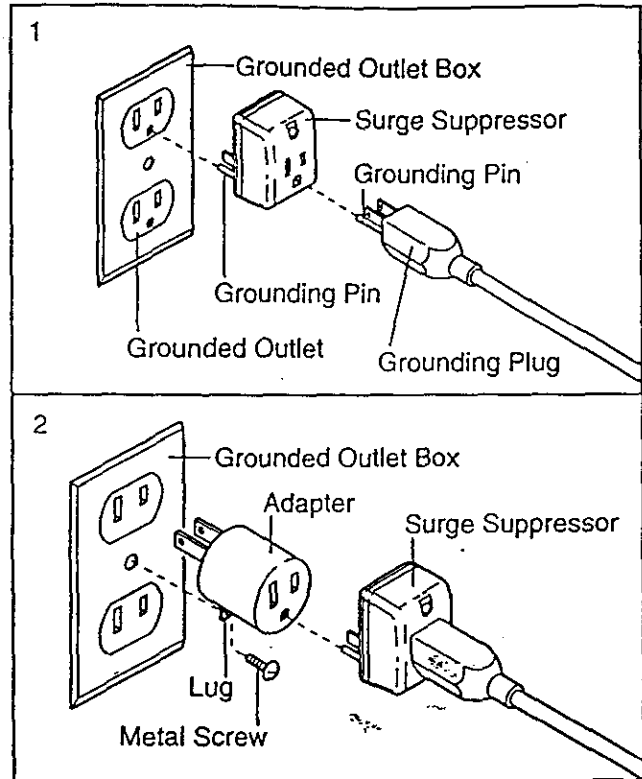

The temporary adapter should be used only until a properly grounded outlet (drawing 1) can be installed by a qualified electrician.

The green-colored rigid ear, lug, or the like extending from the adapter must be connected to a permanent ground such as a properly grounded outlet box cover. Whenever the adapter is used it must be held in place by a metal screw. Some 2-pole receptacle outlet box covers are not grounded. Contact a qualified electrician to determine if the outlet box cover is grounded before using an adapter.

## DIAGRAM OF THE CONSOLE

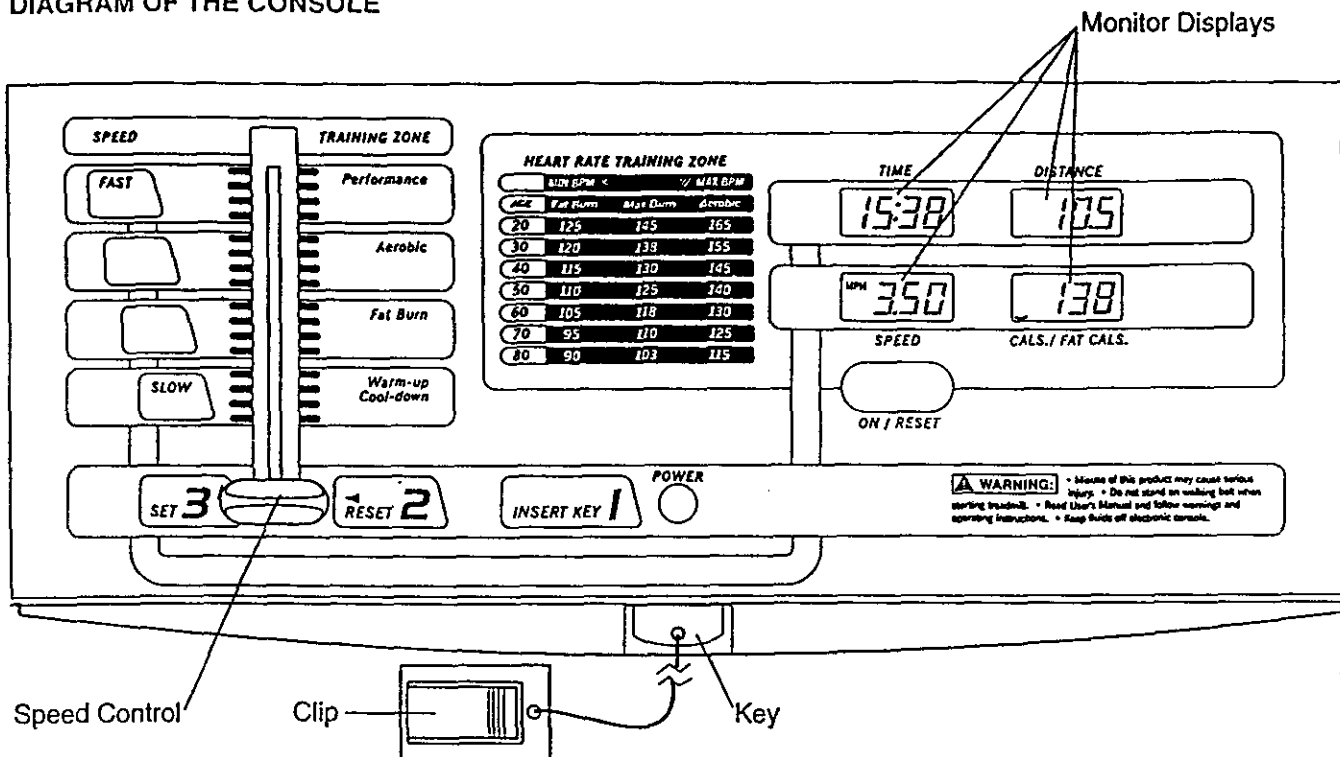

### CAUTION: Before operating the console, read the following precautions.

- Do not stand on the walking belt when turning on the power.
- Always wear the clip (see the drawing above) while using the treadmill. When the key is removed from the console, the walking belt will stop.

- Adjust the speed in small increments.
- The training zones marked beside the speed control are general guidelines only. See page 14 for more information.
- To reduce the possibility of electric shock, keep the console dry. Avoid spilling liquids on the console. Use only a sealable water bottle.

## BATTERY INSTALLATION

The console requires three "AA" batteries (not included). Alkaline batteries are recommended. To install batteries, open the battery cover under the console as shown below. Press three batteries into the battery compartment. Make sure that the negative (-) ends of the batteries are touching the springs. Close the battery cover.

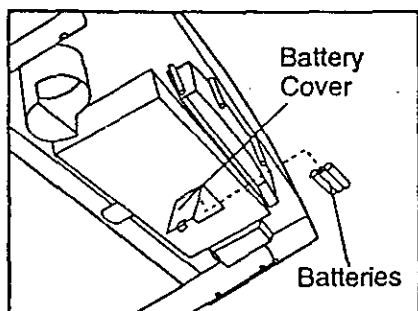

## STEP BY STEP CONSOLE OPERATION

If there is a thin sheet of clear film on the face of the console, remove it.

Before operating the console, make sure that the power cord is properly plugged in. (See HOW TO PLUG IN THE POWER CORD on page 7.)

Next, step onto the foot rails of the treadmill. Find the clip attached to the key (see the drawing above), and slide the clip onto the waistband of your clothing.

Follow the steps on page 9 to operate the console.

**1** Insert the key fully into the power switch.

Inserting the key will not turn on the displays. The displays will turn on when the ON/RESET button is pressed or when the walking belt is started.

Note: If you just installed batteries, the displays will already be on.

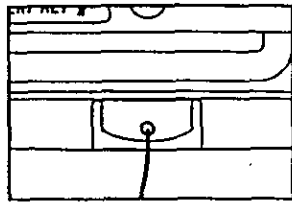

**2** Reset the speed control.

Slide the speed control down to the RESET position. Note: Each time the walking belt is stopped, the speed control must be moved to the RESET position before the walking belt can be restarted.

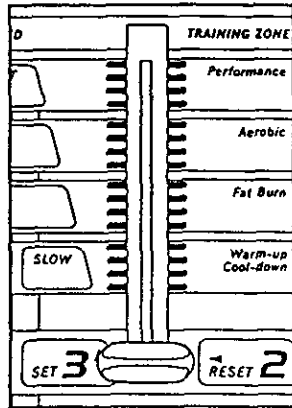

**3** Start the walking belt.

After you have moved the speed control to the RESET position, slowly slide it upward until the walking belt begins to move at slow speed. Carefully step onto the walking belt and begin exercising. Change the speed of the walking belt as desired by sliding the speed control.

To stop the walking belt, step onto the foot rails and slide the speed control to the RESET position.

**4** Follow your progress with the monitor displays.

**TIME display**—This display shows the total time that you have walked or run on the treadmill.



**DISTANCE display**—This display shows the total distance that you have walked or run, in miles.

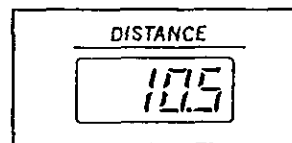

**SPEED display**—This display shows the speed of the walking belt, in miles per hour.

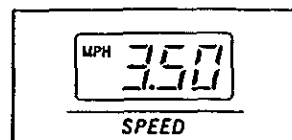

**CALORIES/FAT CALORIES display**—This display shows the approximate numbers of calories and fat calories you have burned. (See FAT BURNING on page 14 for an explanation of fat calories.) Every seven seconds, the display will change from one number to the other. Arrows in the display will indicate which number is currently shown.

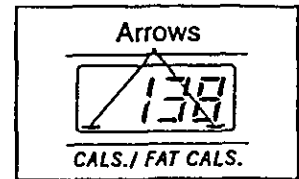

The displays can be reset, if desired, by pressing the ON/RESET button.



**5** When you are finished exercising, stop the walking belt and remove the key.

Step onto the foot rails, stop the walking belt, and remove the key from the console. Store the key in a secure place. After the key is removed, the displays will turn off after about five minutes.

Note: Any time that the walking belt is stopped and no console buttons are pressed for five minutes, the displays will automatically turn off in order to conserve the batteries.

**HOW TO CHANGE THE INCLINE OF THE TREADMILL**

The incline of the treadmill can be changed by raising or lowering the back end. Before changing the incline, remove the key and unplug the power cord.

Hold the rear roller endcap with both hands. When the back end of the treadmill is in the lowest position

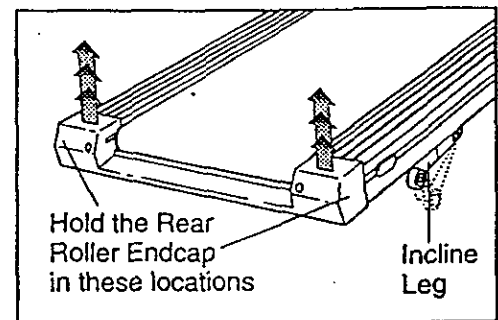

the incline is about 10%. Raise the back end until it clicks into position. (Note: It may be necessary to shake the treadmill lightly so that it clicks into position.) The incline will then be about 5%. Raise the back end again until it clicks into position. The incline will then be about 3%. To lower the back end, first raise it past the highest position, and then lower it. **CAUTION:** Before exercising, push on the back of the treadmill to make sure that the incline legs are locked in position. Do not place objects under the treadmill to change the incline; change the incline only as described above.

# HOW TO FOLD AND MOVE THE TREADMILL

## HOW TO FOLD THE TREADMILL FOR STORAGE

Before folding the treadmill, unplug the power cord. **Caution:** You must be able to safely lift 45 pounds (20 kg) in order to raise, lower, or move the treadmill.

1. Hold the treadmill with your hands in the locations shown at the right. To decrease the possibility of injury, bend your legs and keep your back straight. As you raise the treadmill, make sure to lift with your legs rather than your back. Raise the treadmill about halfway to the vertical position.

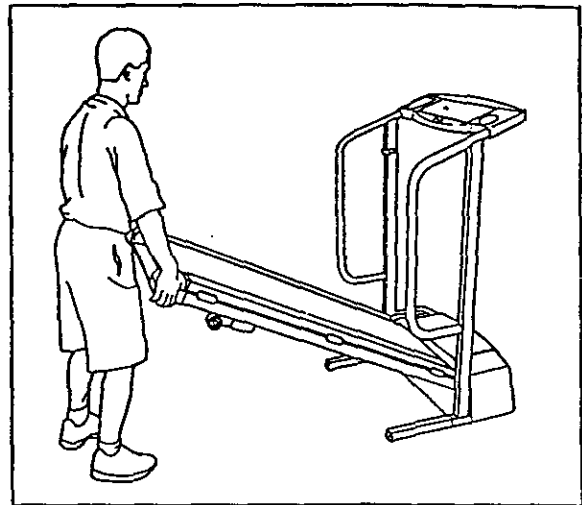

2. Move your right hand to the position shown and hold the treadmill firmly. Raise the treadmill until the storage latch closes over the catch. Make sure that the storage latch is fully engaged over the catch.

To protect the floor or carpet from damage, place a mat under the treadmill. Keep the treadmill out of direct sunlight. Do not leave the treadmill in the storage position in temperatures above 85° Fahrenheit.

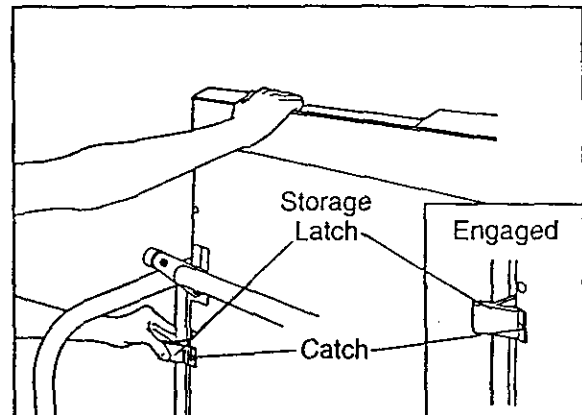

## HOW TO MOVE THE TREADMILL

Before moving the treadmill, convert the treadmill to the storage position as described above. Make sure that the storage latch is closed fully over the catch.

1. Hold the upper ends of the handrails. Place one foot on the base as shown.
2. Tilt the treadmill back until it rolls freely on the front wheels. Carefully move the treadmill to the desired location. Never move the treadmill without tipping it back, or the base pads may come off. To reduce the risk of injury, use extreme caution while moving the treadmill. Do not move the treadmill over an uneven surface.
3. Place one foot on the base, and carefully lower the treadmill until it is resting in the storage position.

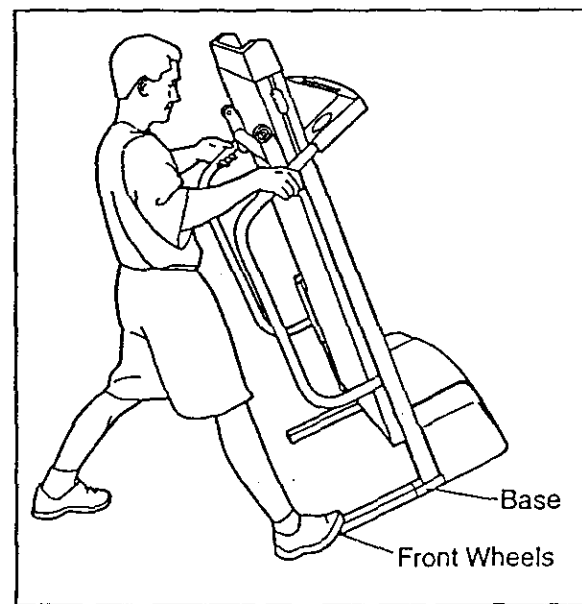



## HOW TO LOWER THE TREADMILL FOR USE

1. Hold the upper end of the treadmill with your right hand as shown. Using your left thumb, press the storage latch and hold it. Pivot the treadmill until the frame and foot rail are past the storage latch.

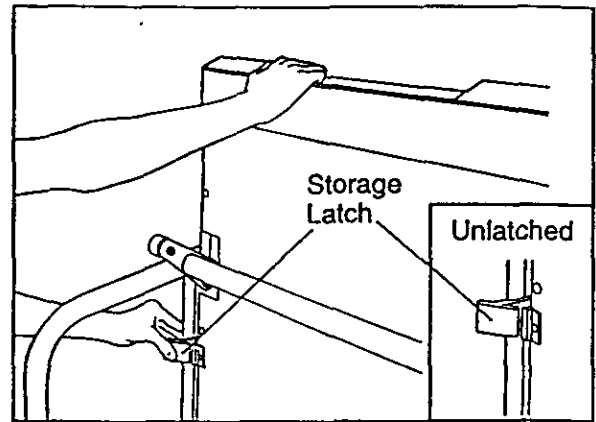

2. Hold the treadmill firmly with both hands, and lower the treadmill to the floor. To decrease the possibility of injury, bend your legs and keep your back straight.

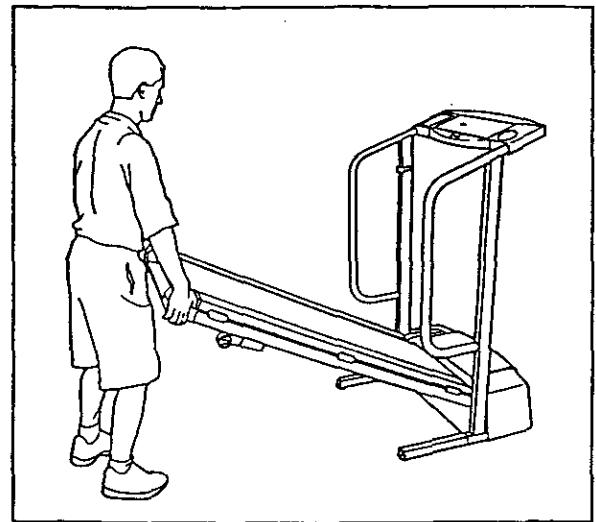

# TROUBLE-SHOOTING

Most treadmill problems can be solved by following the simple steps below. Find the symptom that applies, and follow the steps listed. If further assistance is needed, call our toll-free HELPLINE at 1-800-736-6879, Monday through Saturday, 7 a.m. until 7 p.m. Central Time (excluding holidays).

## 1. SYMPTOM: THE POWER DOES NOT TURN ON

- a. Make sure that the power cord is plugged into a surge suppressor, and that the surge suppressor is plugged into a properly grounded outlet (see page 7). Use only a single-outlet surge suppressor that is UL 1449 listed as a transient voltage surge suppressor (TVSS). The surge suppressor must have a UL suppressed voltage rating of 400 volts or less and a minimum surge dissipation of 450 joules. The surge suppressor must be electrically rated for 120 volts AC and 15 amps.
- b. After the power cord has been plugged in, make sure that the key is fully inserted into the console. See step 1 on page 9.
- c. Check the circuit breaker located on the treadmill near the power cord. If the switch protrudes as shown, the circuit breaker has tripped. To reset the circuit breaker, wait for five minutes and then press the switch back in.

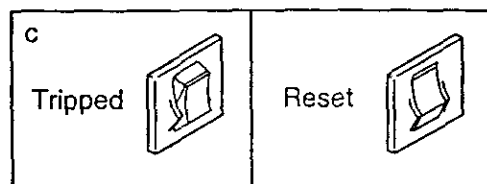

## 2. SYMPTOM: THE POWER TURNS OFF DURING USE

- a. Check the circuit breaker located on the treadmill frame near the power cord (see 1. c. above). If the circuit breaker has tripped, wait for five minutes and then press the switch back in.
- b. Make sure that the power cord is plugged in.
- c. Remove the key from the console. Reinsert the key fully into the console. See step 1 on page 9.
- d. If the treadmill still will not run, please call our toll-free HELPLINE.

## 3. SYMPTOM: THE DISPLAYS OF THE CONSOLE DO NOT FUNCTION PROPERLY

- a. Check the batteries in the console. See BATTERY INSTALLATION on page 8. Most problems are the result of drained batteries.
- b. Remove the six screws from the hood. Carefully remove the hood. Locate the Reed Switch (86) and the Magnet (87) on the left side of the Pulley (85). Turn the Pulley until the Magnet is aligned with the Reed Switch. Make sure that the gap between the Magnet and the Reed Switch is about 1/8". If necessary, loosen the Screw (35) and move the Reed Switch slightly. Retighten the Screw. Re-attach the hood, and run the treadmill for a few minutes to check for a correct speed reading.

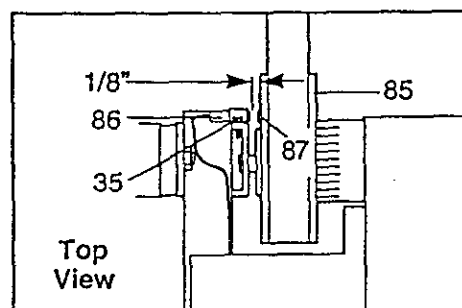

#### 4. SYMPTOM: THE WALKING BELT SLOWS WHEN WALKED ON

a. Use only a UL-listed surge protector, rated at 15 amps, with a 14-gauge cord of five feet or less in length.

b. If the walking belt is overtightened, treadmill performance may decrease and the walking belt may be permanently damaged. Remove the key and **UNPLUG THE POWER CORD**. Using the allen wrench, turn both rear roller adjustment bolts counterclockwise, 1/4 of a turn. When the walking belt is properly tightened, you should be able to lift each side of the walking belt 2 to 3 inches off the walking platform. The center of the walking belt should just touch the walking platform. Be careful to keep the walking belt centered. Plug in the power cord, insert the key and run the treadmill for a few minutes. Repeat until the walking belt is properly tightened.

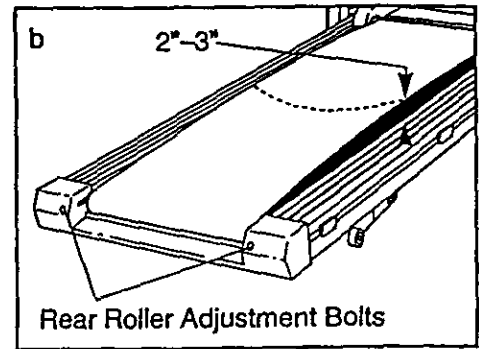

c. If the walking belt still slows when walked on, please call our toll-free HELPLINE.

#### 5. SYMPTOM: THE WALKING BELT IS OFF-CENTER WHEN WALKED ON

a. If the walking belt has shifted to the left, first remove the key and **UNPLUG THE POWER CORD**. Using the allen wrench, turn the left rear roller adjustment bolt clockwise, and the right bolt counterclockwise, 1/4 of a turn each. Be careful not to overtighten the walking belt. Plug in the power cord, insert the key and run the treadmill for a few minutes. Repeat until the walking belt is centered.

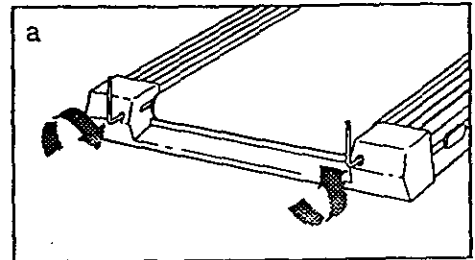

b. If the walking belt has shifted to the right, first remove the key and **UNPLUG THE POWER CORD**. Using the allen wrench, turn the left rear roller adjustment bolt counterclockwise, and the right bolt clockwise, 1/4 of a turn each. Be careful not to overtighten the walking belt. Plug in the power cord, insert the key and run the treadmill for a few minutes. Repeat until the walking belt is centered.

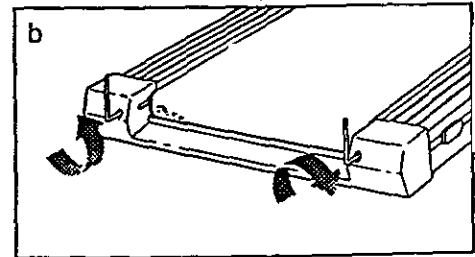

c. If the walking belt slips when walked on, first remove the key and **UNPLUG THE POWER CORD**. Using the allen wrench, turn both rear roller adjustment bolts clockwise, 1/4 of a turn. When the walking belt is correctly tightened, you should be able to lift each side of the walking belt 2 to 3 inches off the walking platform. Be careful to keep the walking belt centered. Plug in the power cord, insert the key and run the treadmill for a few minutes. Repeat until the walking belt is properly tightened.

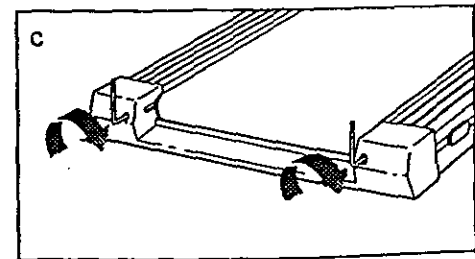

#### 6. SYMPTOM: THE INCLINE SYSTEM STICKS

a. Raise the treadmill to the storage position. See **HOW TO FOLD THE TREADMILL FOR STORAGE** on page 10. Pivot the incline leg several times to break in the incline system.

# REMOVE THIS EXPLODED DRAWING AND PART LIST FROM THE MANUAL

Save this EXPLODED DRAWING and PART LIST for future reference.

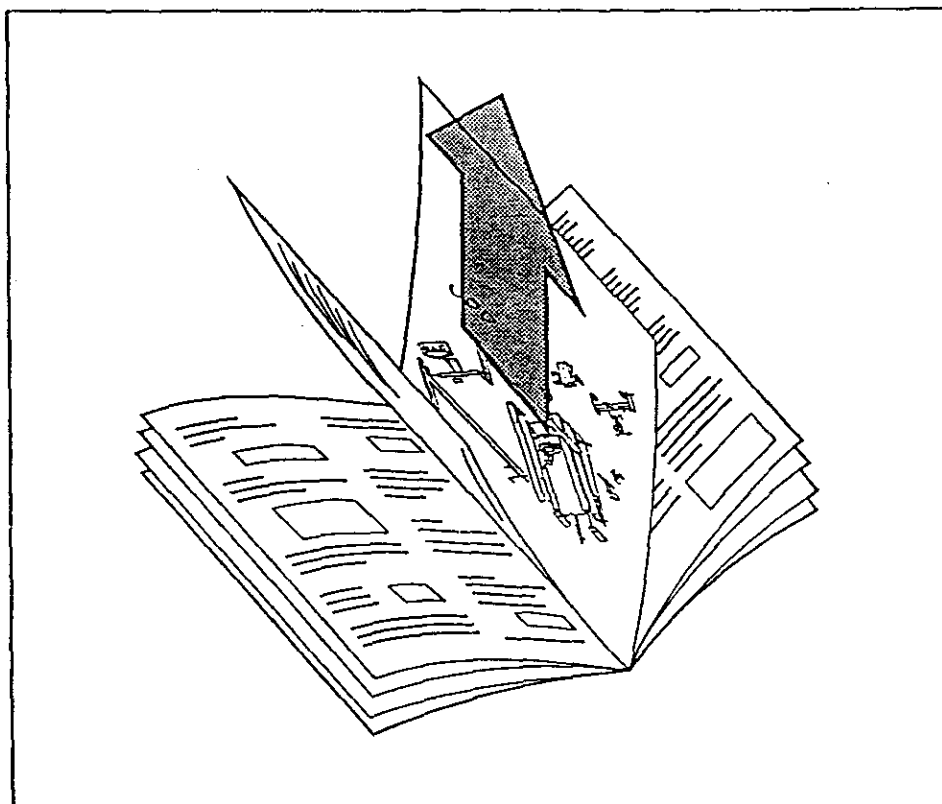

Note: Specifications are subject to change without notice. For information about ordering replacement parts, see the back cover of the User's Manual.

# PART LIST—Model No. 831.297161

R0297A

Key No.	Qty.	Description	Key No.	Qty.	Description
1	1	Key/Clip	48	1	Choke
2	1	Handrail	49	1	Motor Locknut
3	2	Cage Nut	50	2	Belt Guide
4	1	Ratchet Screw	51	1	Belly Pan
5	4	Rear Isolator Screw	52	1	Releasable Tie
6	1	Console Base	53	1	Cable Tie Clamp
7	1	Speed Control Knob	54	1	Motor Belly Pan
8	1	Speed Potentiometer	55	1	11 1/2" Cable Tie
9	1	Battery Cover	56	4	8" Cable Tie
10	2	7 1/2" Cable Tie	57	1	Incline Leg Spacer (long)
11*	1	Console Assembly	58	1	Incline Leg Bolt
12	1	Storage Latch	59	2	Ratchet Screw
13	7	Base Screw/Latch Screw	60	1	Ratchet Spring
14	1	Upright Base	61	1	Ratchet
15	2	Handrail Bolt	62	2	Solid Isolator
16	7	Handrail Washer	63	2	Incline Leg Spacer (long)
17	1	Motor Belt	64	2	Incline Wheel Bolt
18	1	Motor Swivel Nut	65	2	Incline Wheel
19*	1	Motor/Pulley/Flywheel/Fan	66	2	Incline Wheel Nut
20	1	Pulley/Flywheel/Fan	67	1	Incline Leg Plate
21	1	Motor	68	1	Ground Wire
22	3	Motor Tension Bolt	69	1	Incline Leg
23	1	Motor Tension Washer	70	2	Upright Pivot Washer
24	1	Motor Tension Star Washer	71	2	Rear Roller Adj. Bolt
25	1	Motor Swivel Bolt	72	1	Rear Roller Endcap
26	1	Upright Wire Harness	73	1	Allen Wrench
27	2	Ground Wire Screw	74	1	Adhesive Clip
28	1	Hood	75	1	Left Foot Rail
29	1	Hood Shield	76	1	Rear Roller
30	12	Screw	77	4	Platform Screw
31	1	Latch Decal	78	1	Latch Catch
32	2	Handrail Screw	79	1	Walking Platform
33	2	Frame Pivot Bolt	80	1	Walking Belt
34	2	Extension Leg Screw	81	1	Front Roller Adjustment Bolt
35	29	Electronics Screw	82	1	Shock
36	6	Base Pad	83	1	Right Foot Rail
37	2	Wheel Bolt	84	1	Sensor Clip
38	2	Wheel	85	1	Front Roller/Pulley
39	7	Wheel Nut	86	1	Reed Switch
40	1	Controller	87	1	Magnet
41	2	Extension Leg	88	1	Console Wire Harness
42	1	Circuit Breaker	#	1	14" Wire Harness
43	1	Power Cord Grommet	#	1	User's Manual
44	1	Power Cord			
45	2	Upright Spacer			
46	4	Isolator			
47	14	Belly Pan Screw			

\* Includes all parts shown in the box  
 # These parts are not illustrated

# EXPLODED DRAWING—Model No. 831.297161

R0297A

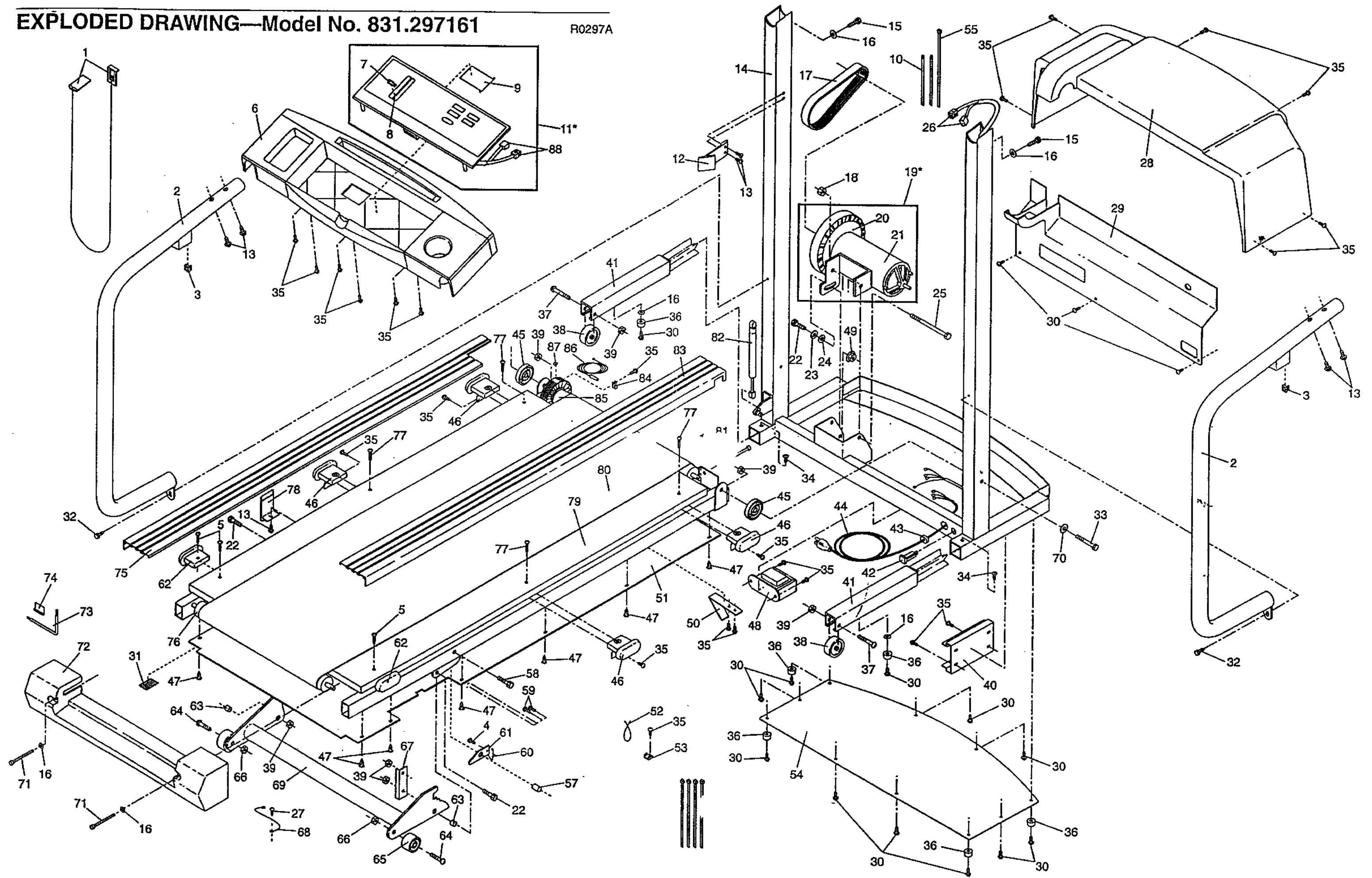



Model No. 831.297161

## QUESTIONS?

If you find that:

- you need help assembling or operating the LIFESTYLER® EXPANSE 600 TL treadmill
- a part is missing
- or you need to schedule repair service

call our toll-free HELPLINE

**1-800-736-6879**

Monday-Saturday, 7 am-7 pm  
Central Time (excluding holidays)

## REPLACEMENT PARTS

If parts become worn and need to be replaced, call the following toll-free number

**1-800-FON-PART  
(1-800-366-7278)**

The model number and serial number of your LIFESTYLER® EXPANSE 600 treadmill are listed on a decal attached to the frame. See the front cover of this manual to find the location of the decal.

All replacement parts are available for immediate purchase or special order when you visit your nearest SEARS Service Center. To request service or to order parts by telephone, call the toll-free numbers listed at the left.

When requesting help or service, or ordering parts, please be prepared to provide the following information:

- The NAME OF THE PRODUCT (LIFESTYLER® EXPANSE 600 treadmill)
- The MODEL NUMBER OF THE PRODUCT (831.297161)
- The KEY NUMBER AND DESCRIPTION OF THE PART (see the EXPLODED DRAWING and PART LIST included in this manual).

## FULL 90 DAY WARRANTY

For 90 days from the date of purchase, if failure occurs due to defect in material or workmanship in this SEARS TREADMILL EXERCISER, contact the nearest SEARS Service Center throughout the United States and SEARS will repair or replace the TREADMILL EXERCISER, free of charge.

This warranty does not apply when the TREADMILL EXERCISER is used commercially or for rental purposes.

This warranty gives you specific legal rights, and you may also have other rights which vary from state to state.

SEARS, ROEBUCK AND CO., DEPT. 817WA, HOFFMAN ESTATES, IL 60179