

PRO-FORM STRENGTH & AEROBIC TRAINING

CROSSTRAINER

SEARS

Model No. 831.297460

Serial No. _____

Write the serial number in the space above for future reference.

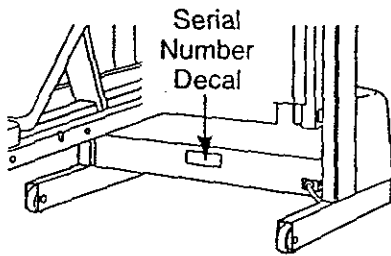

EXERCISE
EQUIPMENT

QUESTIONS

HELPLINE!

1-800-736-6879

CAUTION

Read all precautions and instructions in this manual before using this equipment. Save this manual for future reference.

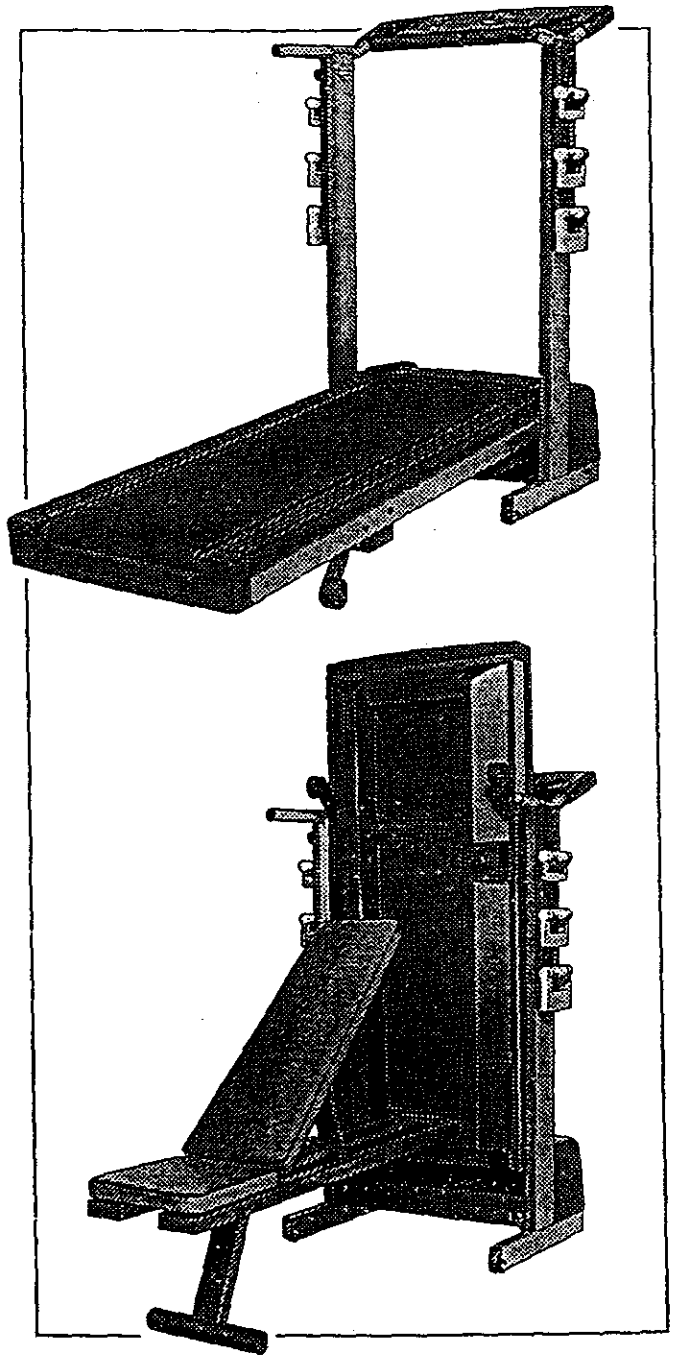

USER'S MANUAL

SEARS, ROEBUCK AND CO., HOFFMAN ESTATES, IL 60179

CROSSTRAINER

TABLE OF CONTENTS

FULL 90 DAY WARRANTY2
IMPORTANT PRECAUTIONS3
BEFORE YOU BEGIN5
ASSEMBLY6
HOW TO OPERATE THE TREADMILL8
HOW TO EXERCISE ON THE TREADMILL12
HOW TO OPERATE THE WEIGHT BENCH14
HOW TO EXERCISE ON THE WEIGHT BENCH15
MAINTENANCE AND TROUBLE-SHOOTING16
HOW TO MOVE THE CROSSTRAINER18
PART LIST19
ORDERING REPLACEMENT PARTSBack Cover

Note: An EXPLODED DRAWING is attached to the center of this manual. Save the EXPLODED DRAWING for future reference.

FULL 90 DAY WARRANTY

For 90 days from the date of purchase, if failure occurs due to defect in material or workmanship in this SEARS TREADMILL EXERCISER, contact the nearest SEARS Service Center throughout the United States and SEARS will repair or replace the TREADMILL EXERCISER, free of charge.

This warranty does not apply when the TREADMILL EXERCISER is used commercially or for rental purposes.

This warranty gives you specific legal rights, and you may also have other rights which vary from state to state.

SEARS, ROEBUCK AND CO., DEPT. 817WA, HOFFMAN ESTATES, IL 60179

IMPORTANT PRECAUTIONS

⚠ WARNING: To reduce the risk of burns, fire, electric shock, or injury to persons, read the following important precautions and information before operating the PROFORM® CROSSTRAINER.

1. It is the responsibility of the owner to ensure that all users of the CROSSTRAINER are adequately informed of all warnings and precautions.
2. Use the CROSSTRAINER only as described in this manual.
3. Place the CROSSTRAINER on a level surface, with eight feet of clearance behind it. Do not place the CROSSTRAINER on a surface that blocks any air openings. To protect the floor or carpet from damage, place a mat under the CROSSTRAINER.
4. Keep the CROSSTRAINER indoors, away from moisture and dust. Do not put the CROSSTRAINER in a garage or covered patio, or near water.
5. Do not operate the CROSSTRAINER where aerosol products are used or where oxygen is being administered.
6. Keep children under 12 and pets away from the CROSSTRAINER at all times.
7. The CROSSTRAINER should be used only by persons weighing 250 pounds or less.
8. The CROSSTRAINER should never be used by more than one person at a time.
9. Wear appropriate exercise clothing when using the CROSSTRAINER. Do not wear loose clothing that could become caught in the treadmill. Athletic support clothes are recommended for both men and women.
10. Always wear athletic shoes when using the CROSSTRAINER. Never use the CROSSTRAINER with bare feet, wearing only stockings, or in sandals.
11. Inspect and tighten all parts of the CROSSTRAINER regularly.
12. When connecting the power cord (see page 8), plug the power cord into a surge suppressor (not included) and plug the surge suppressor into a grounded circuit capable of carrying 15 or more amps. No other appliance should be on the same circuit. Do not use an extension cord.
13. Use only a single-outlet surge suppressor that is UL 1449 listed as a transient voltage surge suppressor (TVSS). The surge suppressor must have a UL suppressed voltage rating of 400 volts or less and a minimum surge dissipation of 450 joules. The surge suppressor must be electrically rated for 120 volts AC and 15 amps.
14. Keep the power cord away from heated surfaces.
15. Never move the walking belt while the power is turned off. Do not operate the CROSSTRAINER if the power cord or plug is damaged, or if the CROSSTRAINER is not working properly. (See BEFORE YOU BEGIN on page 5 if the CROSSTRAINER is not working properly.)
16. Never start the treadmill while you are standing on the walking belt. Always hold the handrails while using the treadmill.
17. The CROSSTRAINER is capable of high speeds. Adjust the speed in small increments to avoid sudden jumps in speed.
18. To reduce the possibility of the treadmill overheating, do not operate the treadmill continuously for longer than one hour.
19. Never leave the treadmill unattended while it is running. Always remove the key when the treadmill is not in use.
20. Do not attempt to raise, lower, or move the CROSSTRAINER until it is properly assembled.
21. You must be able to safely lift 45 pounds (20 kg) in order to raise, lower, or move the CROSSTRAINER.

22. The CROSSTRAINER includes three pairs of hand weights. Other hand-held weights may be used with the CROSSTRAINER; however, do not put other weights on the weight rack, or use weights weighing more than 20 pounds each.

23. Before moving the CROSSTRAINER, make sure that the bench and treadmill are folded to the storage position, and that the lock pins are fully engaged (see HOW TO FOLD THE TREADMILL TO THE STORAGE POSITION on page 11, and HOW TO FOLD THE BENCH TO THE STORAGE POSITION on page 14).

24. Never insert any object into any opening.

25. Always unplug the power cord before performing the maintenance and adjustment procedures described in this manual. Never remove the motor hood unless instructed to do so by an authorized service representative. Servicing other than the procedures in this manual should be performed only by an authorized service representative.

26. The CROSSTRAINER is intended for in-home use only. Do not use the CROSSTRAINER in any commercial, rental, or institutional setting.

⚠ WARNING: Before beginning this or any exercise program, consult your physician. This is especially important for persons over the age of 35 or persons with pre-existing health problems. Read all instructions before using. SEARS assumes no responsibility for personal injury or property damage sustained by or through the use of this product.

SAVE THESE INSTRUCTIONS

The decal shown below has been placed on the CROSSTRAINER. If the decal is missing, or if it is not legible, please call our toll-free HELPLINE to order a free replacement decal (see the back cover of this manual). Apply the decal in the location shown.

⚠ WARNING

- Never allow children to play on or around treadmill.
- Storage latch must be fully engaged before treadmill is moved or stored.

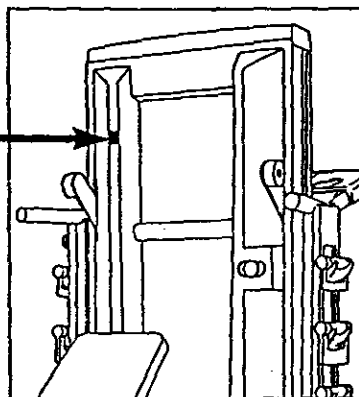

BEFORE YOU BEGIN

Congratulations for purchasing the revolutionary CROSSTRAINER from PROFORM®. The unique CROSSTRAINER offers both aerobic exercise and strength training exercise to help you achieve total fitness in the convenience of your home. And when you're not exercising, the CROSSTRAINER can be folded up, taking a fraction of the space needed for both a treadmill and a bench.

toll-free HELPLINE at 1-800-736-6879, Monday through Saturday, 7 a.m. until 7 p.m. Central Time (excluding holidays). To help us assist you, please note the product model number and serial number before calling. The product model number is 831.297460. The serial number can be found on a decal attached to the CROSSTRAINER (see the front cover of this manual for the location).

For your benefit, read this manual and view the included videocassette before using the CROSSTRAINER. If you have other questions, please call our

Before reading further, please review the drawing below and familiarize yourself with the parts that are labeled.

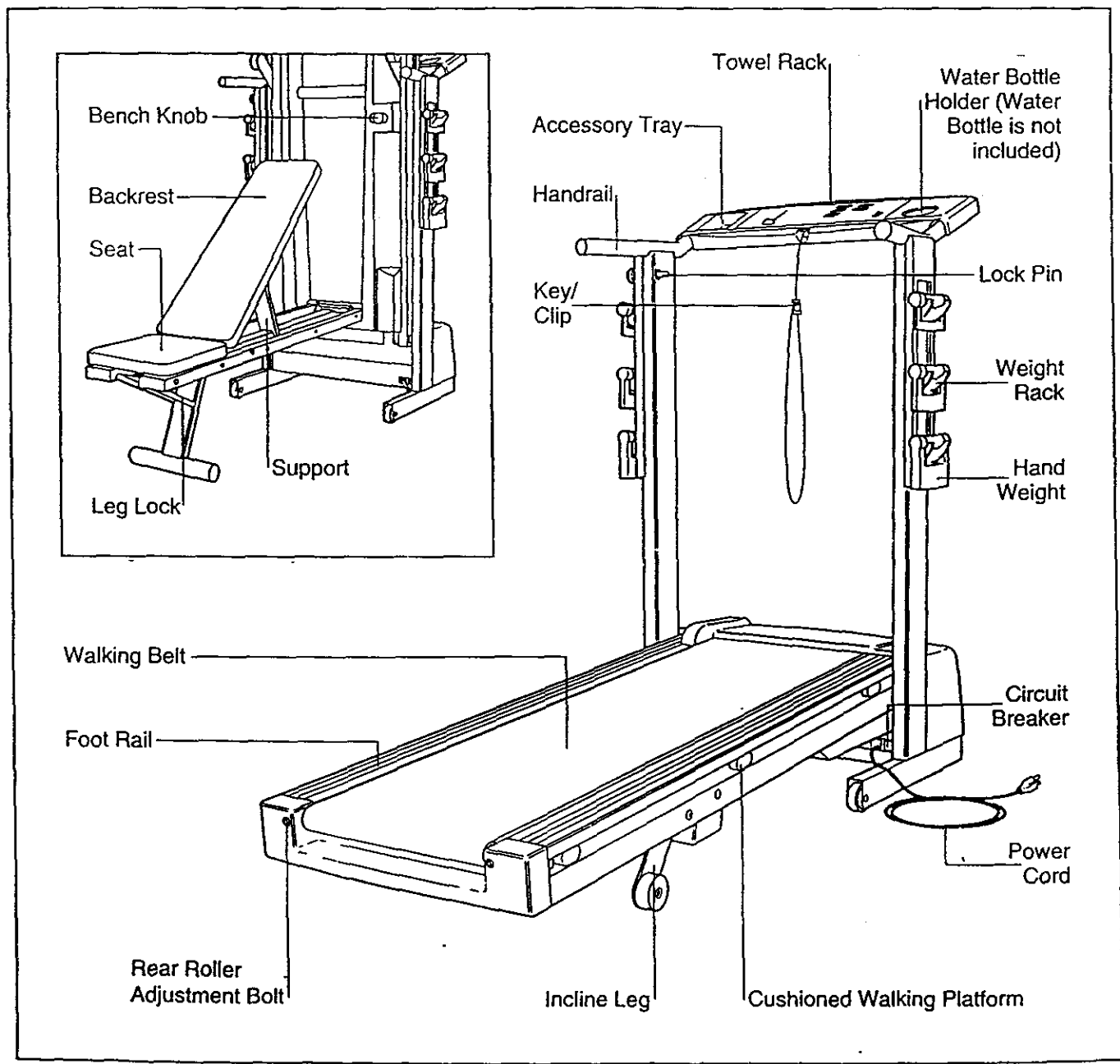

ASSEMBLY

Assembly requires two people. Set the treadmill in a cleared area and remove all packing materials. Do not dispose of the packing materials until assembly is completed. Assembly requires a phillips screwdriver (not included).

1. With the help of a second person, carefully raise the Uprights (102) until the CROSSRAINER is in the position shown at the right.

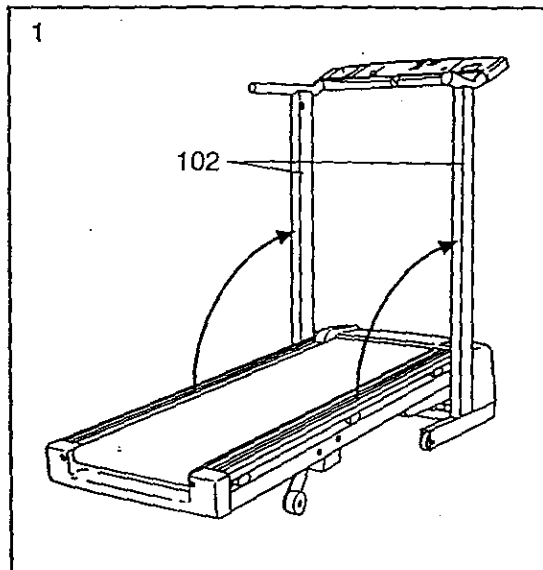

2. Locate the Left Weight Rack (82), which can be identified by the hole near the top. Attach the Left Weight Rack to the left Upright (102) with six Weight Rack Screws (77).

Attach the Right Weight Rack to the right Upright in the same manner (not shown).

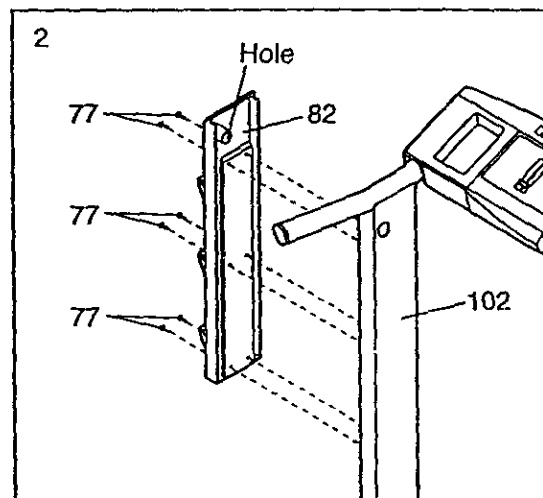

3. Slide the Lock Pin Collar (84) and the Spring (83) onto the Lock Pin (87). Insert the Lock Pin into the left Upright (102) and the Left Weight Rack (82). Tighten the Treadmill Knob (78) onto the Lock Pin.

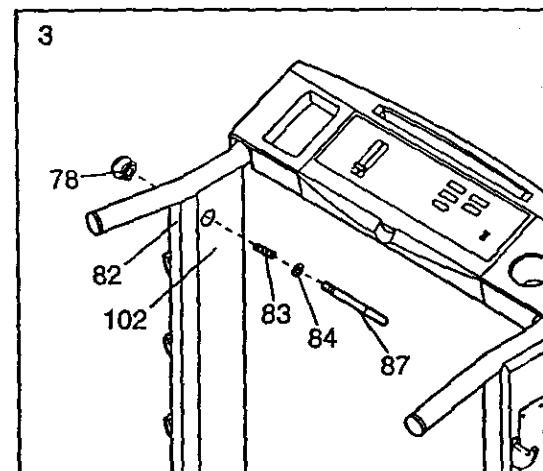

- Put a 2-lb. Weight (79) on the upper hooks on the Right Weight Rack (99). Put a 4-lb. Weight (80) on the center hooks on the Right Weight Rack. Put a 6-lb. Weight (81) on the lower hooks on the Right Weight Rack.

Put the remaining Weights on the Left Weight Rack (not shown).

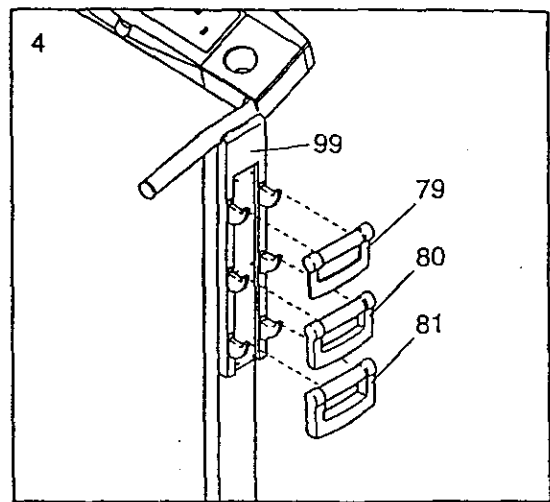

- Remove the backing from the Adhesive Clip (129). Press the Adhesive Clip onto the base of the Uprights (102) in the indicated location. Press the Allen Wrench (116) into the Adhesive Clip.

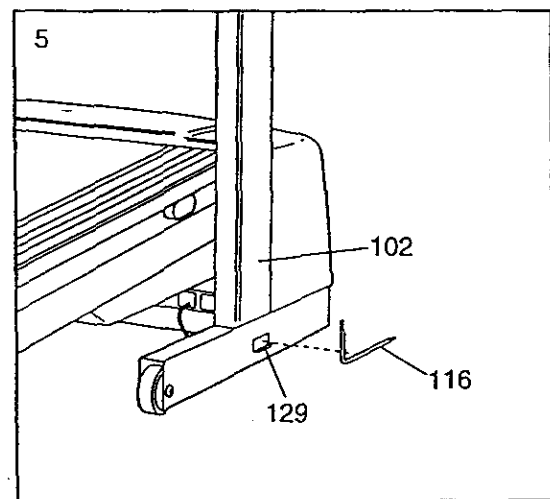

- Make sure that all parts of the CROSSTRAINER are properly tightened. To protect the floor or carpet from damage, place a mat under the CROSSTRAINER.

HOW TO OPERATE THE TREADMILL

HOW TO PLUG IN THE POWER CORD

⚠ DANGER: Improper connection of the equipment-grounding conductor can result in an increased risk of electric shock. Check with a qualified electrician or serviceman if you are in doubt as to whether the product is properly grounded. Do not modify the plug provided with the product—if it will not fit the outlet, have a proper outlet installed by a qualified electrician.

The CROSSTRAINER, like any other type of sophisticated electronic equipment, can be seriously damaged by sudden voltage changes in your home's power. Voltage surges, spikes, and noise interference can result from weather conditions or from other appliances being turned on or off. To decrease the possibility of the CROSSTRAINER being damaged, always use a surge suppressor (see drawing 1 at the right).

Surge suppressors are sold at most hardware stores and department stores. Use only a single-outlet surge suppressor that is UL 1449 listed as a transient voltage surge suppressor (TVSS). The surge suppressor must have a UL suppressed voltage rating of 400 volts or less and a minimum surge dissipation of 450 joules. The surge suppressor must be electrically rated for 120 volts AC and 15 amps.

This product must be grounded. If it should malfunction or break down, grounding provides a path of least resistance for electric current to reduce the risk of electric shock. This product is equipped with a cord having an equipment-grounding conductor and a grounding plug. Plug the power cord into a surge suppressor, and plug the surge suppressor into an appropriate outlet that is properly installed and grounded in accordance with all local codes and ordinances.

This product is for use on a nominal 120-volt circuit, and has a grounding plug that looks like the plug illustrated in drawing 1 at the right. A temporary adapter that looks like the adapter illustrated in drawing 2 may be used to connect the surge suppressor to a 2-pole receptacle as shown in drawing 2 if a properly grounded outlet is not available.

The temporary adapter should be used only until a properly grounded outlet (drawing 1) can be installed by a qualified electrician.

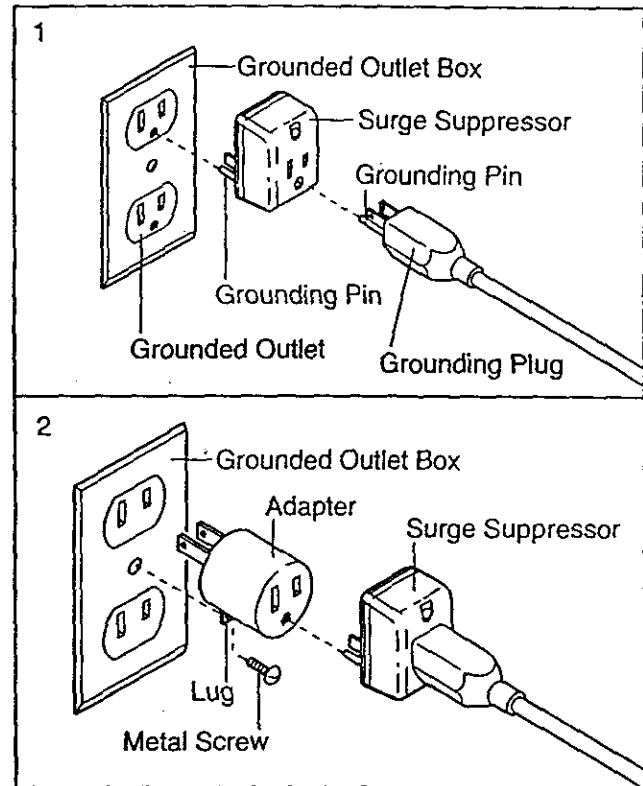

The green-colored rigid ear, lug, or the like extending from the adapter must be connected to a permanent ground such as a properly grounded outlet box cover. Whenever the adapter is used it must be held in place by a metal screw. Some 2-pole receptacle outlet box covers are not grounded. Contact a qualified electrician to determine if the outlet box cover is grounded before using an adapter.

HOW TO LOWER THE TREADMILL FOR USE

To use the treadmill, the bench must be folded to the storage position. See HOW TO FOLD THE BENCH TO THE STORAGE POSITION on page 14.

Caution: You must be able to safely lift 45 pounds (20 kg) in order to lower the treadmill.

To lower the treadmill, hold the upper end of the treadmill with your right hand as shown. Hold the treadmill knob with your left hand and pull it to the left. Pivot the treadmill down a few inches.

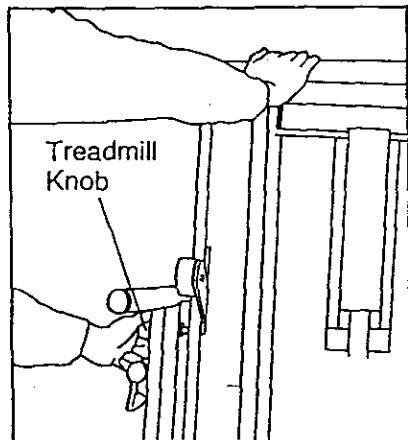

Next, hold the treadmill with both hands as shown below and lower the treadmill to the floor. To decrease the possibility of injury, bend your legs and keep your back straight.

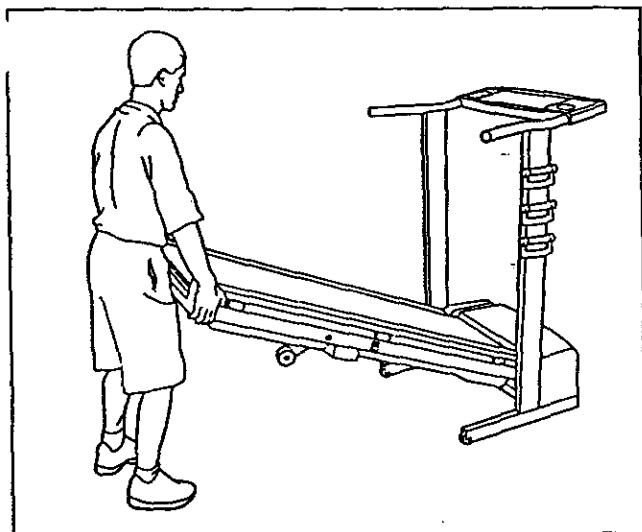

THE PERFORMANT LUBE™ WALKING BELT

The CROSSTRAINER features a walking belt coated with PERFORMANT LUBE™, a high-performance lubricant. **IMPORTANT:** Never apply silicone spray or other substances to the walking belt or the walking platform. Such substances will deteriorate the walking belt and cause excessive wear.

BATTERY INSTALLATION

The console requires three "AA" batteries (not included) for operation. Alkaline batteries are recommended.

To install batteries, first open the battery cover under the console as shown. Next, press three batteries into the battery compartment.

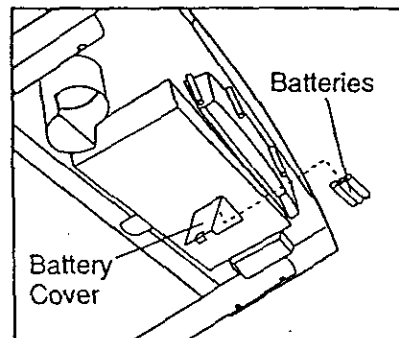

Make sure that the negative ends of the batteries (marked "-") are touching the springs in the battery compartment. Close the battery cover.

Note: If there is a thin sheet of clear film on the face of the console, remove it.

CAUTION: Before operating the console, read the following precautions.

- Do not stand on the walking belt when turning on the power.
- Always wear the clip (see the drawing on page 10) while using the CROSSTRAINER. When the key is removed from the console, the walking belt will stop.
- The CROSSTRAINER is capable of high speeds. Adjust the speed in small increments.
- The training zones marked beside the speed control are general guidelines only. See page 12 and view the included video-cassette for more information.
- To reduce the possibility of electric shock, keep the console dry. Avoid spilling liquids on the console. Use only a sealable water bottle.

DIAGRAM OF THE CONSOLE

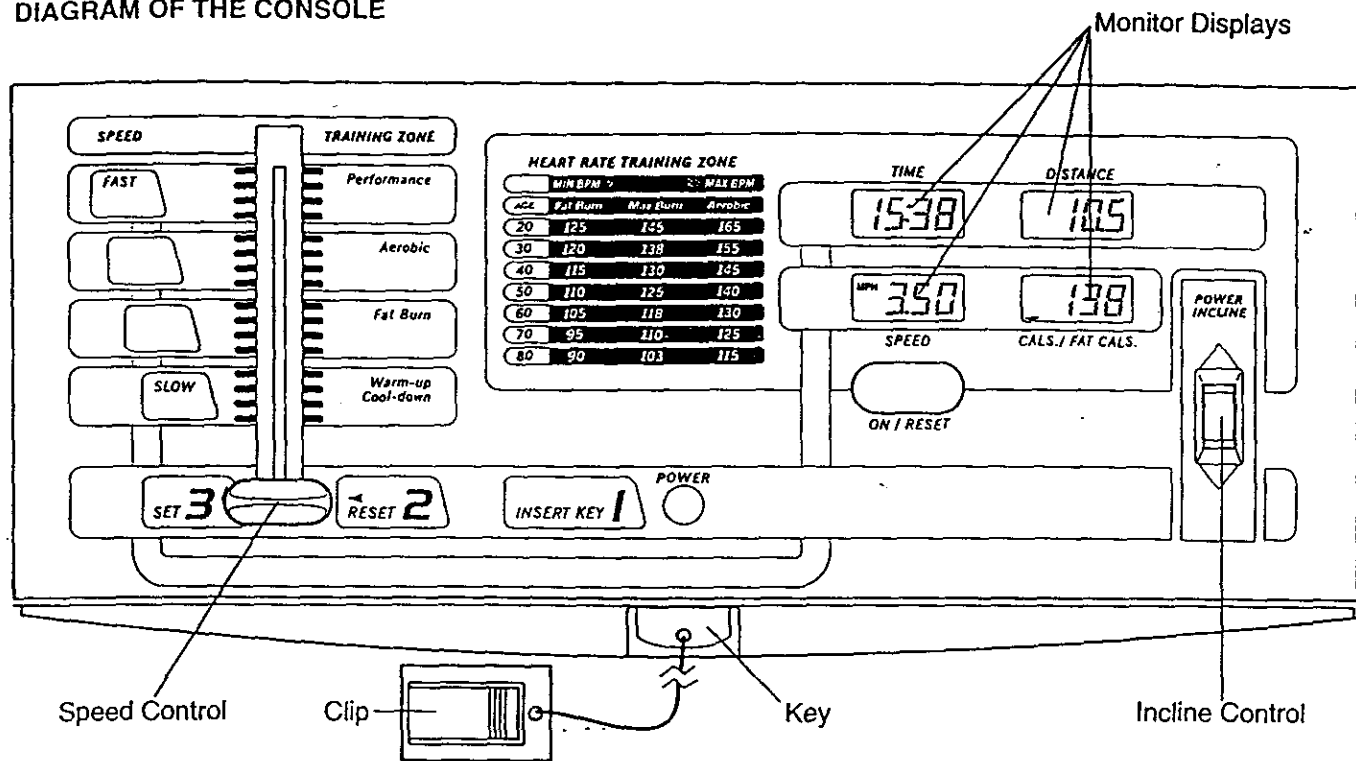

STEP BY STEP CONSOLE OPERATION

Step onto the foot rails of the treadmill. Find the clip attached to the key (see the drawing above), and slide the clip onto the waistband of your clothing.

Follow the steps below to operate the console:

1 Insert the key fully into the power switch.

Inserting the key will not turn on the displays. The displays will turn on when the ON/RESET button is pressed or when the walking belt is started. Note: If you just installed batteries, the displays will already be on.

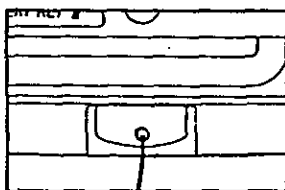

2 Reset the speed control.

Slide the speed control down to the RESET position. Note: Each time the walking belt is stopped, the speed control must be moved to the RESET position before the walking belt can be restarted.

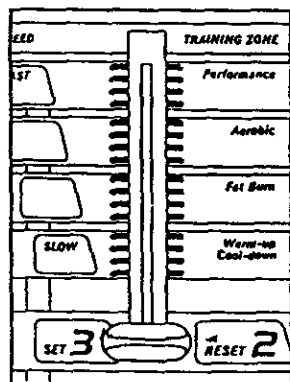

3 Start the walking belt.

After you have moved the speed control to the RESET position, slide it slowly upward until the walking belt begins to move at slow speed. Carefully step onto the walking belt and begin exercising. Change the speed of the walking belt as desired by sliding the speed control.

To stop the walking belt, step onto the foot rails and slide the speed control to the RESET position.

4 Change the incline of the treadmill, if desired.

To increase or decrease the incline, hold down the top or bottom of the incline button. Important: Do not change the incline of the treadmill by placing objects under the treadmill.

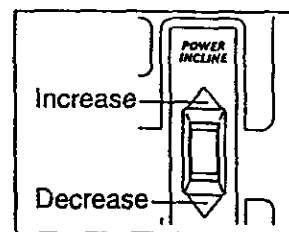

5 Follow your progress with the monitor displays.

TIME display—This display shows the total time that you have walked or run on the CROSSTRAINER.



DISTANCE display—This display shows the total distance that you have walked or run, in miles.



SPEED display—This display shows the speed of the walking belt, in miles per hour.

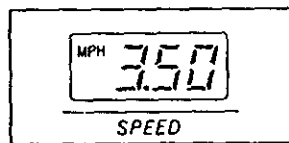

CALORIES/FAT CALORIES display—This display shows the approximate numbers of calories and fat calories you have burned. (See FAT BURNING on page 12 for an explanation of fat calories.) Every seven seconds, the display will change from one number to the other. Arrows in the display will indicate which number is currently shown.

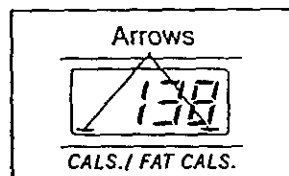

The displays can be reset, if desired, by pressing the ON/RESET button.



6 When you are finished exercising, stop the walking belt and remove the key.

Step onto the foot rails, stop the walking belt, and remove the key from the console. Store the key in a secure place. After the key is removed, the displays will turn off after about five minutes.

Note: Any time that the walking belt is stopped and no console buttons are pressed for five minutes, the displays will automatically turn off in order to conserve the batteries.

HOW TO FOLD THE TREADMILL TO THE STORAGE POSITION

Before folding the treadmill, unplug the power cord. **Caution:** You must be able to safely lift 45 pounds (20 kg) in order to raise the treadmill.

Hold the treadmill in the locations shown below. To decrease the possibility of injury, bend your legs and keep your back straight. As you raise the treadmill, make sure to lift with your legs rather than your back. Raise the treadmill until it is almost vertical.

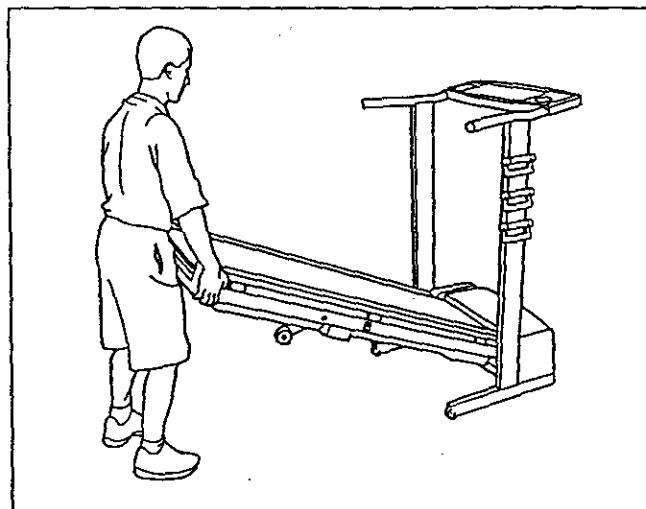

Next, hold the upper end of the treadmill with your right hand as shown. Using your left hand, pull the treadmill knob to the left. Pivot the treadmill until the lock pin is aligned with the hole in the side of the treadmill frame (refer to the inset drawing).

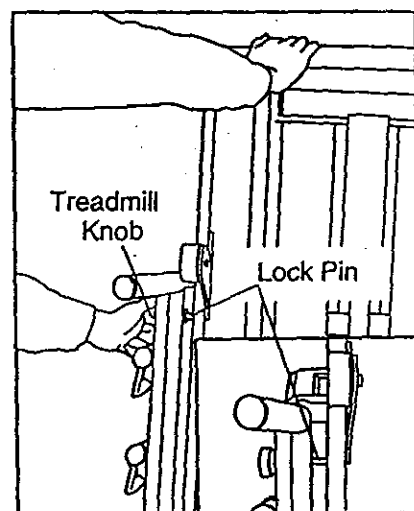

Slowly release the knob. Make sure that the lock pin is inserted into the hole in the treadmill frame.

Note: To protect the floor or carpet from damage, place a mat under the CROSSTRAINER. Keep the CROSSTRAINER out of direct sunlight. Do not leave the CROSSTRAINER in the storage position in temperatures above 85° Fahrenheit.

HOW TO EXERCISE ON THE TREADMILL

⚠ WARNING: Before beginning this or any exercise program, consult your physician. This is especially important for individuals over the age of 35 or individuals with pre-existing health problems.

The following guidelines will help you to plan your exercise program. Remember—these are general guidelines only. For more information, view the included videocassette.

EXERCISE INTENSITY

Whether your goal is to burn fat or to strengthen your cardiovascular system, the key to achieving the desired results is to exercise with the proper intensity. The proper intensity level can be found by using your heart rate as a guide. The chart below shows recommended heart rates for fat burning and aerobic exercise. (This chart is also found on the console.)

HEART RATE TRAINING ZONE			
	MIN BPM	MAX BPM	
AGE	Fat Burn	Max Burn	Aerobic
20	125	145	165
30	120	138	155
40	115	130	145
50	110	125	140
60	105	118	130
70	95	110	125
80	90	103	115

To find the proper heart rate for you, first find your age on the left side of the chart (ages are rounded off to the nearest ten years). Next, find the three numbers to the right of your age. The three numbers are your "training zone." The lower two numbers are recommended heart rates for fat burning; the higher number is the recommended heart rate for aerobic exercise.

Fat Burning

To burn fat effectively, you must exercise at a relatively low intensity level for a sustained period of time. During the first few minutes of exercise, your body uses easily accessible *carbohydrate calories* for energy. Only after the first few minutes does your body begin to use stored *fat calories* for energy. If your goal is to burn fat, adjust the speed and incline of the treadmill until your heart rate is near one of the lower two numbers in your

training zone. It may also be helpful to set the speed control on the console to **FAT BURN** to help you maintain the proper intensity level. (See page 10.)

Aerobic Exercise

If your goal is to strengthen your cardiovascular system, your exercise must be "aerobic." Aerobic exercise is activity that requires large amounts of oxygen for prolonged periods of time. This increases the demand on the heart to pump blood to the muscles, and on the lungs to oxygenate the blood. For aerobic exercise, adjust the speed and incline of the treadmill until your heart rate is near the highest number in your training zone. It may also be helpful to set the speed control on the console to **AEROBIC** to help you maintain the proper intensity level. (See page 10.)

High Performance Athletic Conditioning

If your goal is high performance athletic conditioning, set the speed control on the console to **PERFORMANCE** to help you maintain the proper intensity level. (See page 10.) Note: During the first few weeks of your exercise program, keep your heart rate near the low end of your training zone.

HOW TO MEASURE YOUR HEART RATE

To measure your heart rate, stop exercising and place two fingers on your wrist as shown. Take a six-second heartbeat count, and multiply the result by ten to find your heart

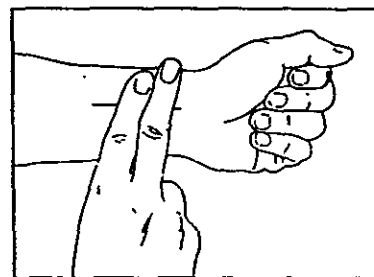

rate. (A six-second count is used because your heart rate drops quickly when you stop exercising.) If your heart rate is too high or too low, adjust the speed or incline of the treadmill accordingly.

WORKOUT GUIDELINES

A well-rounded workout includes the following three important parts:

A Warm-up

Start each workout with 5 to 8 minutes of stretching and light exercise (see **SUGGESTED STRETCHES** on page 13). A proper warm-up increases your body temperature, heart rate, and circulation in preparation for exercise.

Training Zone Exercise

After warming up, increase the intensity of your exercise until your heart rate is in your training zone for 20 to 60 minutes. (During the first few weeks of your exercise program, do not keep your heart rate in your training zone for longer than 20 minutes.) Breathe regularly and deeply as you exercise—do not hold your breath.

A Cool-down

Finish each workout with 5 to 8 minutes of stretching

to cool down. This will increase the flexibility of your muscles and will help to prevent post-exercise problems.

Exercise Frequency

To maintain or improve your condition, complete three workouts each week, with at least one day of rest between workouts. After a few months, you may complete up to five workouts each week if desired.

The key to success is to make exercise a regular and enjoyable part of your everyday life.

SUGGESTED STRETCHES

The correct form for several basic stretches is shown at the right. Move slowly as you stretch—never bounce.

1. Toe Touch Stretch

Stand with your knees bent slightly and slowly bend forward from your hips. Allow your back and shoulders to relax as you reach down toward your toes as far as possible. Hold for 15 counts, then relax. Repeat 3 times. Stretches: Hamstrings, back of knees, and back.

2. Hamstring Stretch

Sit with one leg extended. Bring the sole of the opposite foot toward you and rest it against the inner thigh of your extended leg. Reach toward your toes as far as possible. Hold for 15 counts, then relax. Repeat 3 times for each leg. Stretches: Hamstrings, lower back, and groin.

3. Calf/Achilles Stretch

With one leg in front of the other, reach forward and place your hands against a wall. Keep your back leg straight and your back foot flat on the floor. Bend your front leg, lean forward and move your hips toward the wall. Hold for 15 counts, then relax. Repeat 3 times for each leg. To cause further stretching of the achilles tendons, bend your back leg as well. Stretches: Calves, achilles tendons, and ankles.

4. Quadriceps Stretch

With one hand against a wall for balance, reach back and grasp one foot with your other hand. Bring your heel as close to your buttocks as possible. Hold for 15 counts, then relax. Repeat 3 times for both legs. Stretches: Quadriceps and hip muscles.

Inner Thigh Stretch

Sit with the soles of your feet together and your knees outward. Pull your feet toward your groin area as far as possible. Hold for 15 counts, then relax. Repeat 3 times. Stretches: Quadriceps and hip muscles.

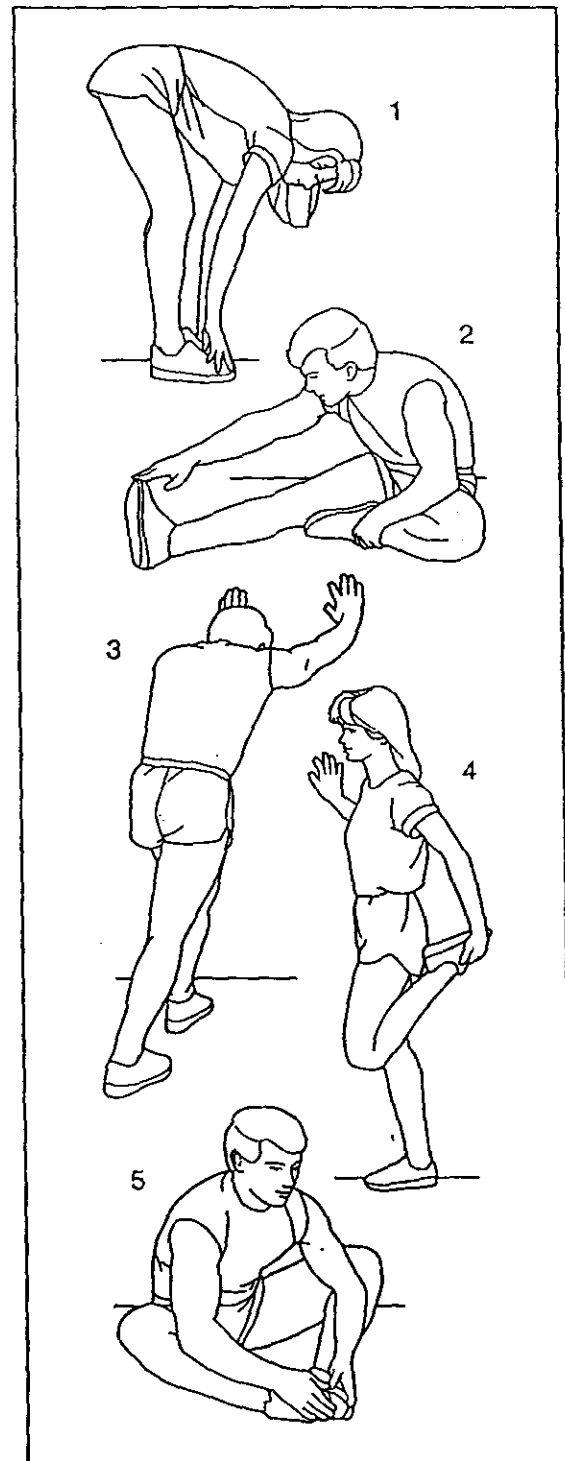

HOW TO OPERATE THE WEIGHT BENCH

HOW TO LOWER THE BENCH FOR USE

To use the bench, the treadmill must be folded to the storage position. See **HOW TO FOLD THE TREADMILL TO THE STORAGE POSITION** on page 11.

To lower the bench, first hold the end of the bench as shown—do not hold the leg. Using your right hand, slide the bench knob to the right as far as possible. Make sure that the knob is moved all of the way to the “bench” position.

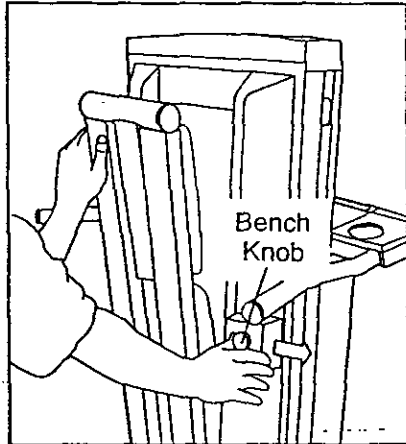

Carefully lower the bench until the leg is resting on the floor.

HOW TO ADJUST THE BACKREST

The backrest can be used in a level position or in either of two inclined positions. When the bench is first lowered, the backrest will be in the level position. To adjust the backrest to one of the inclined positions, first raise the backrest and lower the support (see the drawing below). Rest the end of the support against either of the backrest stops as shown. Make sure that the support is resting against one of the backrest stops.

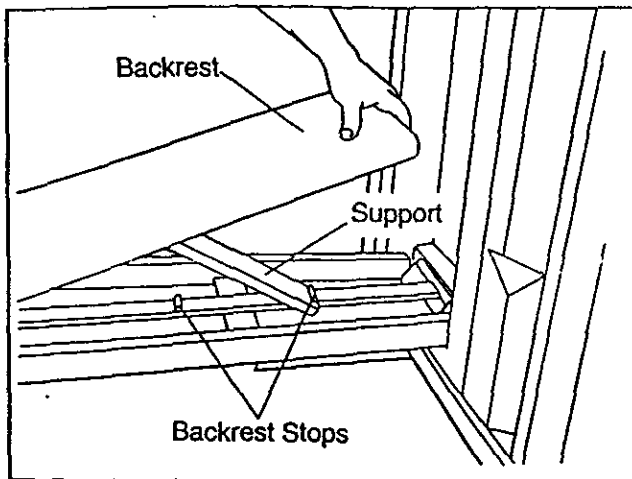

To adjust the backrest to the level position, first raise the backrest slightly. Pivot the end of the support in the direction shown by the arrow. Lower the backrest onto the bench frame.

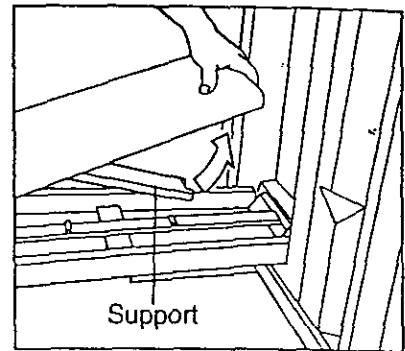

HOW TO FOLD THE BENCH TO THE STORAGE POSITION

Before folding the bench, make sure that the backrest is adjusted to the level position.

Hold the bench seat with your right hand as shown. Using your fingers, push up the leg lock.

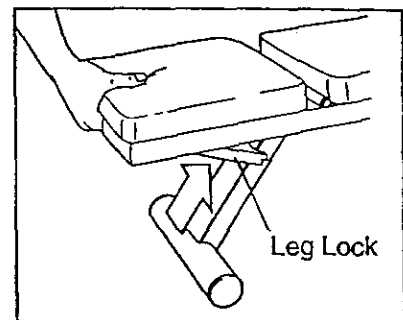

Next, raise the bench to the vertical position and hold it in place. Using your right hand, slide the bench knob to the left as far as possible. Make sure that the knob is moved all of the way to the “treadmill” position. Refer to the inset drawing. Make sure that the lock pin is inserted in the hole into the bench frame.

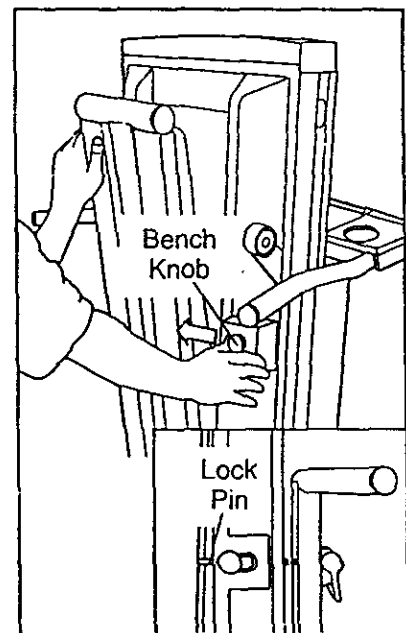

HOW TO EXERCISE ON THE WEIGHT BENCH

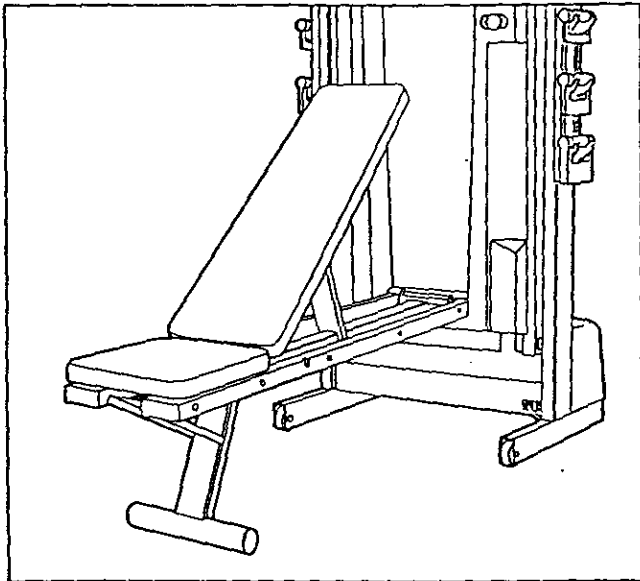

The CROSSTRAINER offers a variety of exercises designed to trim, tone, and strengthen the body. Please read these guidelines before using the weight bench. For more information, view the included video-cassette.

WARNING: Before beginning any exercise program, consult your physician. This is especially important for persons over the age of 35 or persons with pre-existing health problems.

STRENGTH TRAINING GUIDELINES

Your strength training program should include 3 workouts each week. To give your body time to rest, workouts should be on alternating days, such as Monday, Wednesday, and Friday.

Instead of waiting for a convenient time to exercise, plan a specific time. The morning hours work well for many, and the self-discipline required to rise early and exercise may result in greater productivity throughout the day. For others, exercising before dinner offers a chance to wind down from the day's activities. Whatever time you choose, be consistent and stick with it.

Each workout should include the following three essential parts: (1) a warm-up, (2) 6 to 10 exercises, and (3) a cool-down.

Begin each workout with 5 to 8 minutes of stretching to warm up (see SUGGESTED STRETCHES on page 13). This will prepare the body for exercise by increasing circulation, delivering more oxygen to the muscles, and raising the body temperature.

Next, perform 6 to 10 of the exercises shown on the included chart. To give balance and variety to your workouts, vary the exercises from workout to workout. Begin with 1 set of 12 repetitions for each exercise. (A "repetition" is one complete cycle of an exercise, such as one sit-up. A "set" is a series of repetitions performed without pausing.) As your fitness level increases, perform 2 or 3 sets for each exercise. Always rest for at least 1 minute after each set. When you can complete 3 sets of 12 repetitions without difficulty, you may choose to use heavier weights. **CAUTION:** The CROSSTRAINER includes three pairs of hand weights. Other hand-held weights may be used with the CROSSTRAINER; however, do not put other weights on the weight rack, or use weights weighing more than 20 pounds each.

Finish each workout with 5 to 8 minutes of stretching to cool down. This will increase your flexibility, and will help to reduce soreness.

It is very important to avoid overdoing it during the first few months of your exercise program, and to progress at your own pace. **CAUTION:** If you feel pain or dizziness at any time, stop immediately and begin cooling down.

EXERCISE FORM

For the best results, correct form is important. Maintaining proper form means moving through the full range of motion for each exercise, and moving only the appropriate parts of the body. The photographs on the included chart show the correct starting and ending positions for each exercise. Make sure to perform each exercise with a smooth, steady motion. Exhale as you exert yourself, and inhale as you return to the starting position; never hold your breath.

STAYING MOTIVATED

To stay motivated, try listening to music or watching television while you exercise. It may also be helpful to work out with a training partner. If desired, use a calendar to keep a record of your workouts, and write key body measurements at the end of every month.

Remember, the key to lasting results is to make exercise a regular and enjoyable part of your daily life.

MAINTENANCE AND TROUBLE-SHOOTING

Most problems can be solved by following the steps in this section. If further assistance is needed, call our toll-free HELPLINE at 1-800-736-6879, Monday through Saturday, 7 a.m. until 7 p.m. Central Time (excluding holidays).

PROBLEM: The power does not turn on

SOLUTION: a. Make sure that the power cord is plugged into a surge suppressor, and that the surge suppressor is plugged into a properly grounded outlet (see page 8). Use only a single-outlet surge suppressor that is UL 1449 listed as a transient voltage surge suppressor (TVSS). The surge suppressor must have a UL suppressed voltage rating of 400 volts or less and a minimum surge dissipation of 450 joules. The surge suppressor must be electrically rated for 120 volts AC and 15 amps.

b. After the power cord has been plugged in, make sure that the key is fully inserted into the console. See step 1 on page 10.

c. Check the circuit breaker located on the treadmill frame near the power cord. If the switch protrudes as shown, the circuit breaker has tripped. To reset the circuit breaker, wait for five minutes and then press the switch back in.

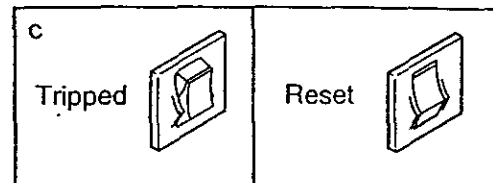

PROBLEM: The power turns off during use

SOLUTION: a. Check the circuit breaker located on the treadmill frame near the power cord (see the drawing above). If the circuit breaker has tripped, wait for five minutes and then press the switch back in.

b. Make sure that the power cord is plugged in.

c. Remove the key from the console. Reinsert the key fully into the console. See step 1 on page 10.

d. If the treadmill still will not run, please call our toll-free HELPLINE.

PROBLEM: The displays of the console do not function properly

SOLUTION: a. Check the batteries in the console. See BATTERY INSTALLATION on page 9. Most problems are the result of drained batteries.

b. Remove the six screws from the hood. Carefully remove the hood. Locate the Reed Switch (45) and the Magnet (44) on the left side of the Pulley (49). Turn the Pulley until the Magnet is aligned with the Reed Switch. Make sure that the gap between the Magnet and the Reed Switch is about 1/8". If necessary, loosen the Screw (53) and move the Reed Switch slightly. Retighten the Screw. Re-attach the hood, and run the treadmill for a few minutes to check for a correct speed reading.

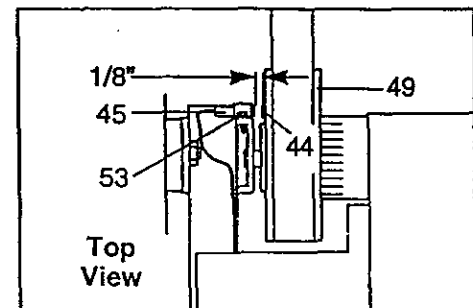

PROBLEM: The walking belt is off-center or slips when walked on

SOLUTION: a. If the walking belt has shifted to the left, first remove the key and **UNPLUG THE POWER CORD**. Using the allen wrench, turn the left rear roller adjustment bolt clockwise, and the right bolt counterclockwise, 1/4 of a turn each. Be careful not to overtighten the walking belt. Plug in the power cord, insert the key and run the treadmill for a few minutes. Repeat until the walking belt is centered.

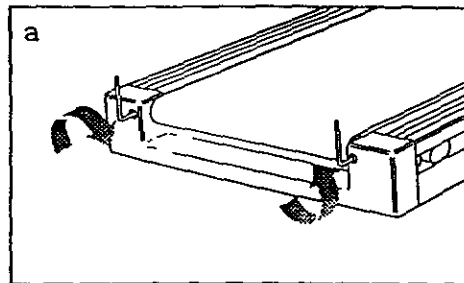

b. If the walking belt has shifted to the right, first remove the key and **UNPLUG THE POWER CORD**. Using the allen wrench, turn the left rear roller adjustment bolt counterclockwise, and the right bolt clockwise, 1/4 of a turn each. Be careful not to overtighten the walking belt. Plug in the power cord, insert the key and run the treadmill for a few minutes. Repeat until the walking belt is centered.

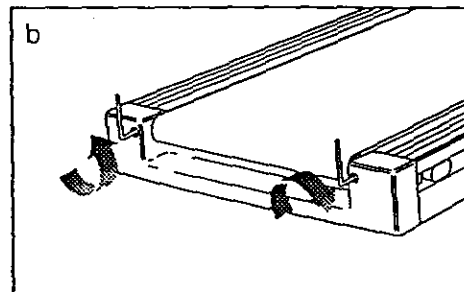

c. If the walking belt slips when walked on, first remove the key and **UNPLUG THE POWER CORD**. Using the allen wrench, turn both rear roller adjustment bolts clockwise, 1/4 of a turn. When the walking belt is correctly tightened, you should be able to lift each side of the walking belt 2 to 3 inches off the walking platform. The center of the walking belt should just touch the walking platform. Be careful to keep the walking belt centered. Plug in the power cord, insert the key and run the treadmill for a few minutes. Repeat until the walking belt is properly tightened.

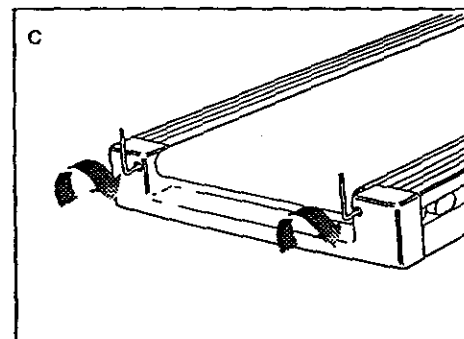

PROBLEM: The walking belt slows when walked on

SOLUTION: a. Use only a single-outlet surge suppressor that is UL 1449 listed as a transient voltage surge suppressor (TVSS). The surge suppressor must have a UL suppressed voltage rating of 400 volts or less and a minimum surge dissipation of 450 joules. The surge suppressor must be electrically rated for 120 volts AC and 15 amps.

b. If the walking belt is overtightened, treadmill performance may decrease and the walking belt may be permanently damaged. Remove the key and **UNPLUG THE POWER CORD**. Using the allen wrench, turn both rear roller adjustment bolts counterclockwise, 1/4 of a turn. When the walking belt is properly tightened, you should be able to lift each side of the walking belt 3 to 4 inches off the walking platform. The center of the walking belt should just touch the walking platform. Be careful to keep the walking belt centered. Plug in the power cord, insert the key and run the treadmill for a few minutes. Repeat until the walking belt is properly tightened.

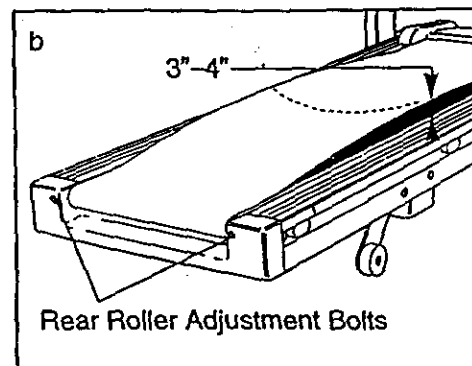

c. If the walking belt still slows when walked on, please call our toll-free HELPLINE.

HOW TO MOVE THE CROSSTRAINER

Before moving the CROSSTRAINER, make sure that the bench and treadmill are folded to the storage position, and that the lock pins are fully engaged (see HOW TO FOLD THE TREADMILL TO THE STORAGE POSITION on page 11, and HOW TO FOLD THE BENCH TO THE STORAGE POSITION on page 14).

To move the CROSSTRAINER, first hold the handrails and place one foot on the base as shown.

Next, tilt the CROSSTRAINER back until it rolls freely on the front wheels. Carefully move the CROSSTRAINER to the desired location. Place one foot on the base, and carefully lower the CROSSTRAINER until it is resting on the base. Never move the CROSSTRAINER without tipping it back, or the base pads may come off. To reduce the risk of injury, use extreme caution while moving the CROSSTRAINER. Do not move the CROSSTRAINER over an uneven surface.

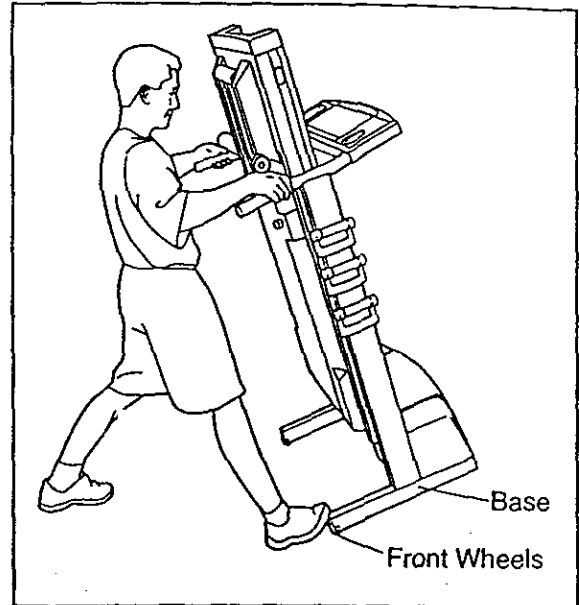

PART LIST—Model No. 831.297460

R0797A

Key No.	Part No.	Qty.	Description	Key No.	Part No.	Qty.	Description
1	139533	1	Backrest	72	139587	1	Latch Spring
2	013468	6	Backrest Screw	73	116927	4	Tie Clamp
3	119425	6	Nut	74	108080	2	Spring Screw
4	013399	4	Backrest Support Bolt	75	116926	2	Releasable Tie
5	139260	1	Left Backrest Frame	76	016057	4	7 1/2" Cable Tie
6	139264	1	Right Backrest Frame	77	013540	12	Weight Rack Screw
7	139257	2	Bench Frame Spacer	78	139511	2	Lock Knob
8	139089	1	Bench Bracket	79	139586	2	2-lb. Weight
9	013578	2	Bench Bracket Bolt	80	139430	2	4-lb. Weight
10	115260	1	Bench Pivot Bolt	81	139431	2	6-lb. Weight
11	013578	2	Bench Support Pivot Bolt	82	139387	1	Left Weight Rack
12	139256	1	Backrest Support	83	100076	1	Lock Knob Spring
13	139270	1	Bench Adjustment	84	100110	1	Lock Pin Collar
14	139529	1	Bench Seat	85	114270	1	Incline Motor Spacer
15	140500	1	Bench Pin	86	100486	1	Latch Clip
16	139290	1	Bench Back	87	139373	1	Treadmill Lock Pin
17	138853	10	Plastic Fastener	88	116980	2	Handrail Cap
18	100290	2	Bench Leg Cap	89	118016	1	Motor Belt
19	139305	1	Bench Leg	90	126996	4	Console Base Screw
20	118471	1	Bench Leg Pivot Bolt	91	130251	2	Frame Guide
21	140357	1	Bench Poster (small)	92	131606	1	Console Base
22	139795	1	Bench Poster (large)	93	131161	1	Speed Control Knob
23	139367	1	Bench Bottom	94	128093	1	Speed Potentiometer
24	100606	2	Rear Roller Adj. Bolt	95	129639	1	Battery Cover
25	014063	5	Adjustment Washer	96*	138683	1	Console
26	013322	2	Rear Roller Endcap Screw	97	139796	1	Bench Video
27	105444	2	Endcap Screw	98	119038	1	Key/Clip
28	131635	2	Rear Roller Endcap	99	139388	1	Right Weight Rack
29	138141	1	Latch Warning Decal	100*	139794	1	Motor Assembly
30	140501	1	Belly pan	101	107503	1	Motor Pivot Bolt
31	NSP	1	Frame	102	139140	1	Upright Base
32	140502	1	Solid Isolator	103	139767	1	Shock
33	100691	4	Rear Isolator Screw	104	132031	1	Frame Guide
34	125802	4	Isolator Screw	105	122812	1	Motor Tension Washer
35	140503	4	Isolator	106	014117	1	Tension Star Washer
36	133845	1	Rear Roller	107	120867	1	Motor Tension Nut
37	140505	1	Left Foot Rail	108	140513	1	Wire Harness
38	140506	1	Right Foot Rail	109	117806	2	Front Wheel Bolt
39	140507	1	Walking Belt	110	139090	2	Front Wheel
40	012149	1	Motor Pivot Nut	111	012056	2	Front Wheel Nut
41	128272	4	Walking Platform Screw	112	130993	1	Choke
42	140509	1	Walking Platform	113	124669	1	Power Cord
43	137625	2	Upright Spacer	114	109382	1	Circuit Breaker
44	100498	1	Magnet	115	124695	1	Power Cord Grommet
45	138680	1	Reed Switch/Sensor Wire	116	128457	1	Allen Wrench
46	131090	1	Reed Switch Clip	117	126650	4	Base Pad
47	114261	1	Ground Wire	118	013581	2	Upright Pivot Bolt
48	014086	2	Upright Pivot Washer	119	014132	2	Upright Pivot Washer
49	140510	1	Front Roller/Pulley	120	139145	1	Belly Pan
50	111430	2	Cage Nut	121	125819	4	Plastic Stand-off
51	112609	1	Front Roller Adj. Bolt	122	105988	1	Lift Board
52	109265	2	Belt Guide	123	137857	1	Controller
53	133867	42	Screw	124	139051	1	Hood Cover
54	013547	4	Incline Bracket Bolt	125	140514	1	Hood
55	139117	1	Incline Bracket	126	139744	2	Backrest Spacer
56	115523	1	Incline Motor	127	134949	2	Pinch Pin Cap
57	119425	12	Incline Nut	128	013300	6	Front Belly Pan Screw
58	139585	1	Bench Lock Pin	129	016028	1	Adhesive Clip
59	139778	2	Bench Latch Bolt	130	031108	1	Incline Switch
60	014140	2	Bench Latch Washer	131	114261	1	8" Green Ground Wire
61	139197	1	Latch Frame Spacer	132	140527	1	Bench Leg Lock
62	139267	1	Latch Slide	133	139296	2	Bench Lock Bracket
63	139783	1	Latch Bracket	134	124423	2	Bench Lock Bolt
64	012152	2	Latch Bolt	135	100427	2	Flange Nut
65	139301	1	Latch Bracket	#	112083	1	8" Blue Wire, 2 Female
66	013399	2	Incline Leg Bolt	#	102246	1	8" White Wire, 2 Female
67	130868	2	Wheel Bolt	#	103823	1	14" Wire Harness
68	139095	2	Wheel	#	139150	1	User's Manual
69	139794	1	Motor				
70	126747	1	Flywheel				
71	139044	1	Incline Leg				

EXPLODED DRAWING—Model No. 831.297460

R0797A

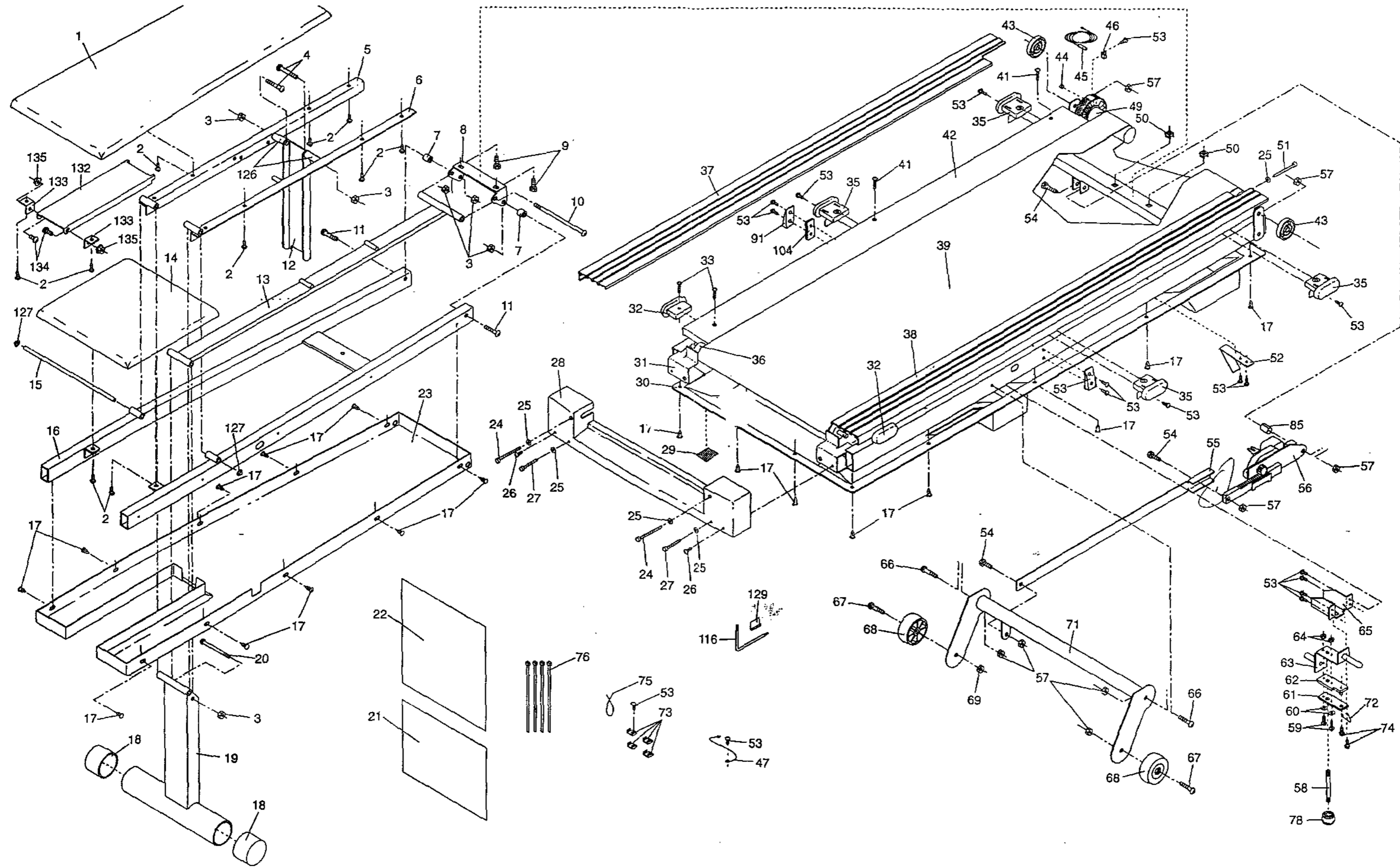

Remove this EXPLODED DRAWING from the user's manual. Save this EXPLODED DRAWING for future reference.

To identify parts shown on this EXPLODED DRAWING, refer to the PART LIST on page 19 of the user's manual.

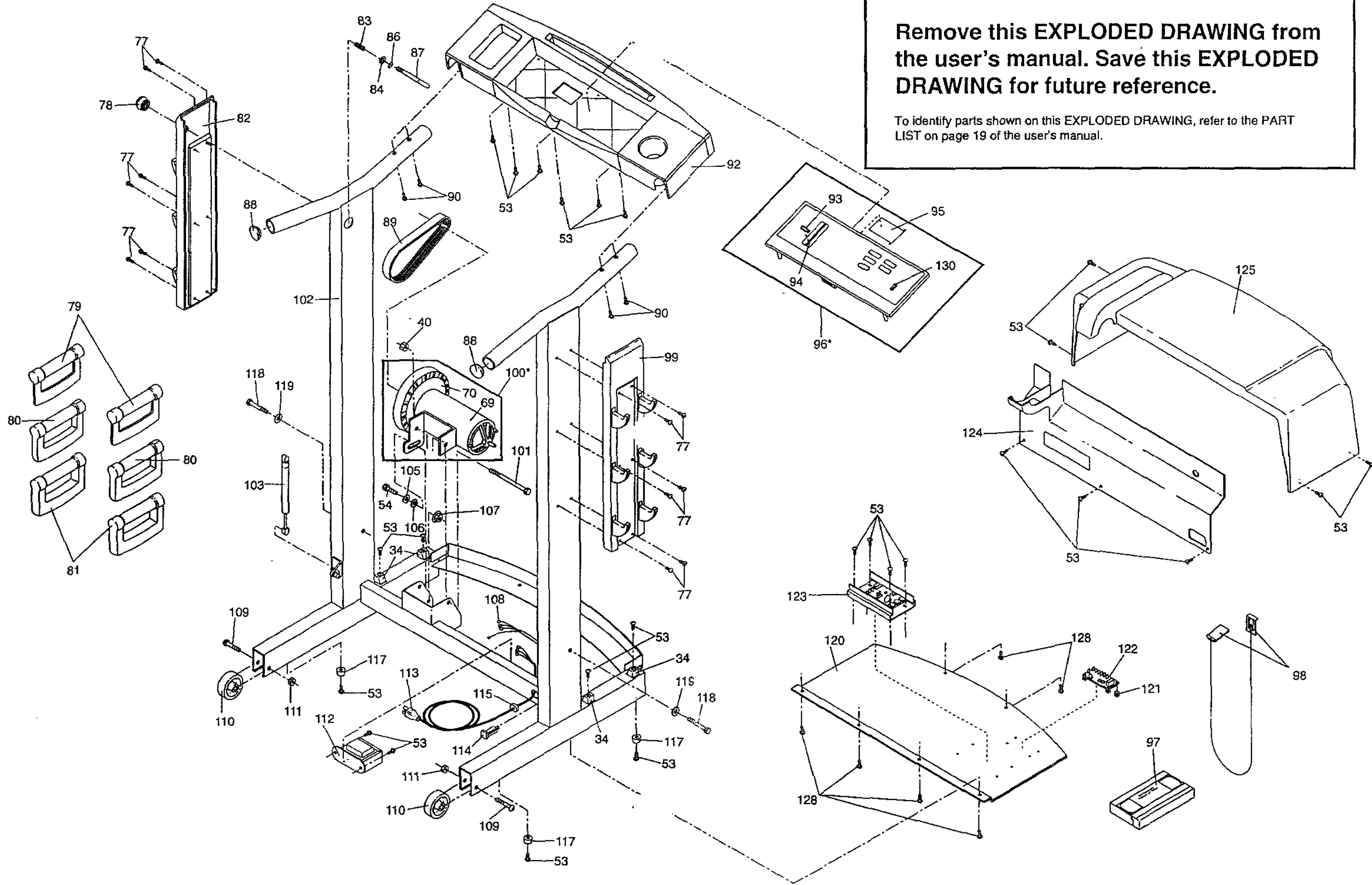

SEARS

Model No. 831.297460

QUESTIONS?

If you find that:

- you need help assembling or operating the PROFORM® CROSSTRAINER
- a part is missing
- or you need to schedule repair service

call our toll-free HELPLINE

1-800-736-6879

Monday–Saturday, 7 am–7 pm
Central Time (excluding holidays)

REPLACEMENT PARTS

If parts become worn and need to be replaced, call the following toll-free number

**1-800-FON-PART
(1-800-366-7278)**

The model number and serial number of your PROFORM® CROSSTRAINER are listed on a decal attached to the frame. See the front cover of this manual to find the location of the decal.

All replacement parts are available for immediate purchase or special order when you visit your nearest SEARS Service Center. To request service or to order parts by telephone, call the toll-free numbers listed at the left.

When requesting help or service, or ordering parts, please be prepared to provide the following information:

- The NAME OF THE PRODUCT (PROFORM® CROSSTRAINER)
- The MODEL NUMBER OF THE PRODUCT (831.297460)
- The PART NUMBER OF THE PART (see the PART LIST on page 19 and the EXPLODED DRAWING attached to the center of this manual)
- The DESCRIPTION OF THE PART (see the PART LIST on page 19 and the EXPLODED DRAWING attached to the center of this manual).