

PRO-FORM REBEL

RECUMBENT BIKE & ELLIPTICAL CROSSTRAINER

Model No. 831.285870

Serial No. _____

Write the serial number in the space above for reference.

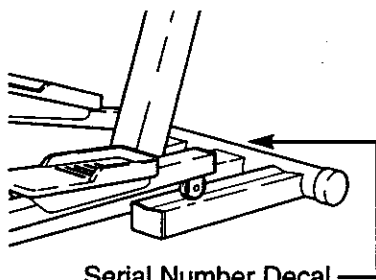

EXERCISE
EQUIPMENT

QUESTIONS

HELPLINE!

1-800-736-6879

Patent Pending

CAUTION

Read all precautions and instructions in this manual before using this equipment. Save this manual for future reference.

USER'S MANUAL

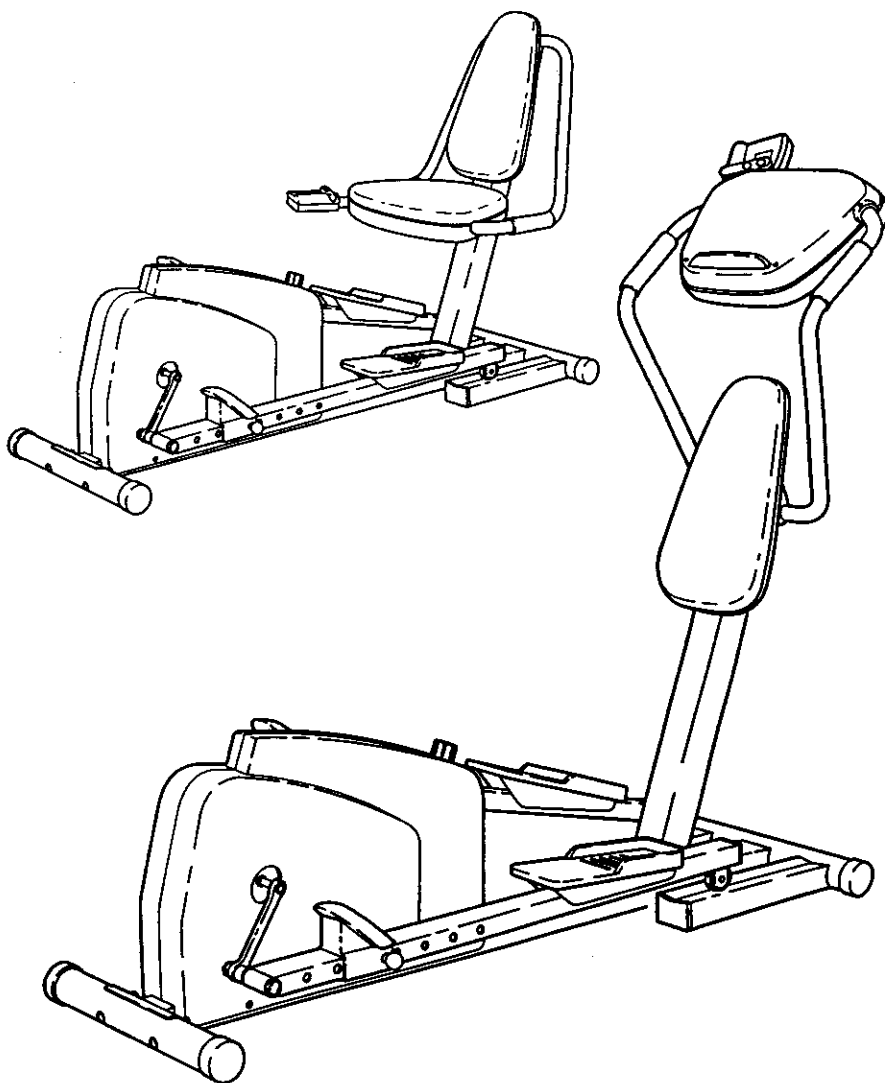

SEARS, ROEBUCK AND CO., HOFFMAN ESTATES, IL 60179

TABLE OF CONTENTS

IMPORTANT PRECAUTIONS	2
BEFORE YOU BEGIN	3
PART IDENTIFICATION CHART	4
ASSEMBLY	5
HOW TO USE THE PROFORM® REBEL	7
MAINTENANCE	10
CONDITIONING GUIDELINES	12
PART LIST	14
EXPLODED DRAWING	15
ORDERING REPLACEMENT PARTSBack Cover
FULL 90 DAY WARRANTYBack Cover

IMPORTANT PRECAUTIONS

WARNING: To reduce the risk of serious injury, read the following important precautions before using the PROFORM® Rebel Recumbent Bike and Elliptical Crosstrainer.

1. Read all instructions in this manual before using the REBEL.
2. It is the responsibility of the owner to ensure that all users of the REBEL are adequately informed of all precautions.
3. Place the REBEL on a level surface, with a mat beneath it to protect the floor or carpet. Keep the REBEL indoors, away from moisture and dust.
4. Inspect and tighten all parts regularly. Replace any worn parts immediately.
5. Keep children under the age of 12 and pets away from the REBEL at all times.
6. The REBEL should not be used by persons weighing more than 250 pounds.
7. Wear appropriate exercise clothing when using the REBEL. Always wear athletic shoes for foot protection.
8. Always hold the handlebars when mounting, dismounting and using the REBEL. Step onto and off the pedal that is in the lowest position when mounting and dismounting.
9. When you stop exercising, allow the pedals to slowly come to a stop.
10. Keep your back straight when using the REBEL. Do not arch your back.
11. If you feel pain or dizziness while exercising, stop immediately and begin cooling down.
12. The REBEL is intended for in-home use only. Do not use it in any commercial, rental or institutional setting.
13. The pulse sensor is not a medical device. Various factors, including the user's movement, may affect the accuracy of heart rate readings. The pulse sensor is intended only as an exercise aid in determining heart rate trends in general.

WARNING: Before beginning this or any exercise program, consult your physician. This is especially important for persons over the age of 35 or persons with pre-existing health problems. Read all instructions before using. SEARS assumes no responsibility for personal injury or property damage sustained by or through the use of this product.

BEFORE YOU BEGIN

Congratulations for selecting the revolutionary PRO-FORM® REBEL Recumbent Bike and Elliptical Crosstrainer. The REBEL is an incredibly smooth exerciser that moves your feet in a natural elliptical path, minimizing the impact on your knees and ankles. The unique REBEL can easily be converted from an elliptical crosstrainer to a recumbent bike, giving you two machines in one. Welcome to a whole new world of natural, elliptical-motion exercise from PROFORM.

For your benefit, read this manual carefully before you use the REBEL. If you have additional questions,

please call our toll-free HELPLINE at 1-800-736-6879, Monday through Saturday, 7 a.m. until 7 p.m. Central Time (excluding holidays). To help us assist you, please note the product model number and serial number before calling. The model number is 831.285870. The serial number can be found on a decal attached to the REBEL (see the front cover of this manual).

Before reading further, please look at the drawing below and familiarize yourself with the parts that are labeled.

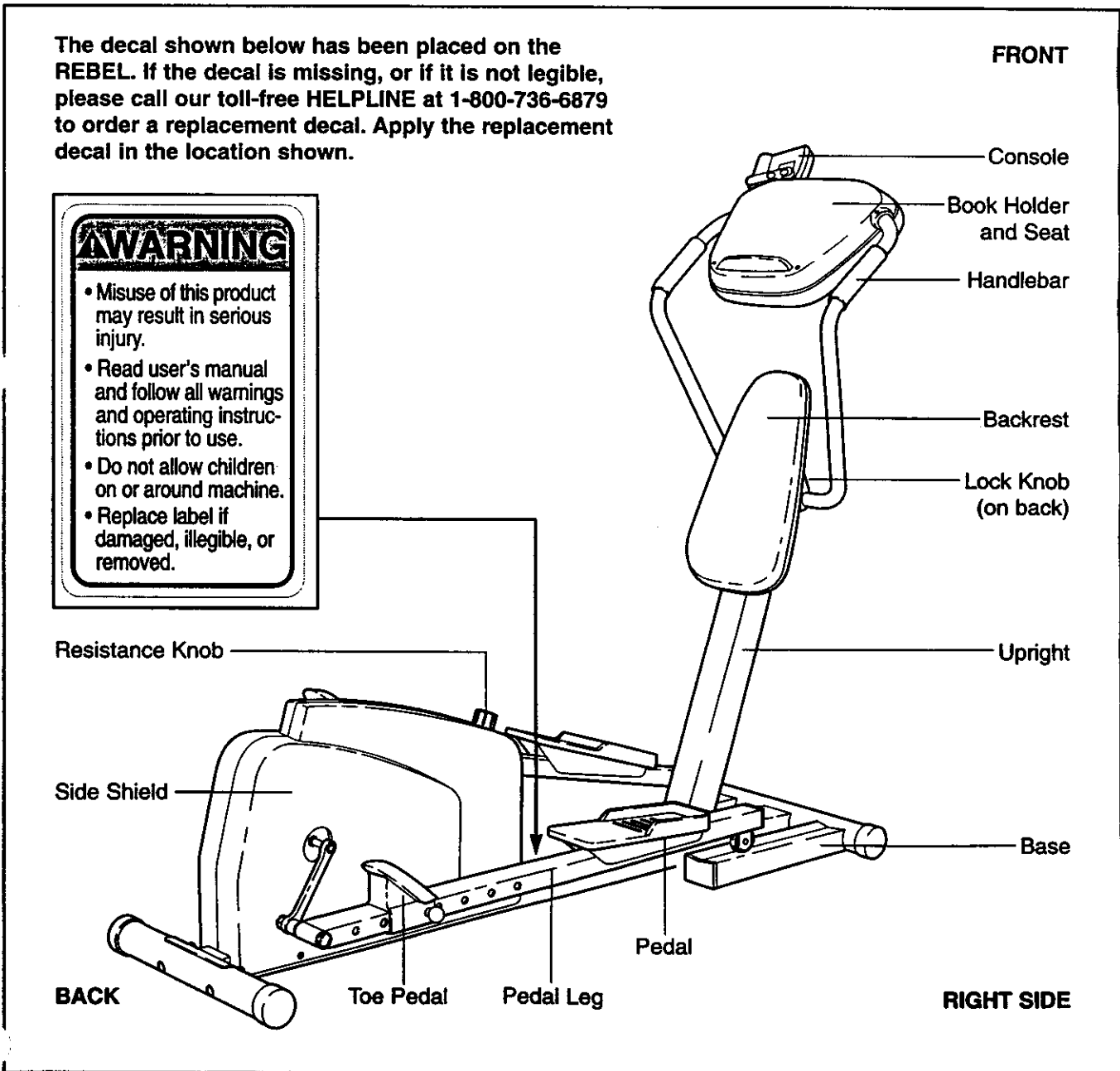

PART IDENTIFICATION CHART

Use the chart below to identify the small parts used in assembly. The number in parenthesis below each part is the key number of the part, from the PART LIST on page 14. The number after the dash indicates the

quantity needed for assembly. **Note: Some small parts may have been pre-attached for shipping. If a part is not in the parts bag, check to see if it has been pre-attached.**

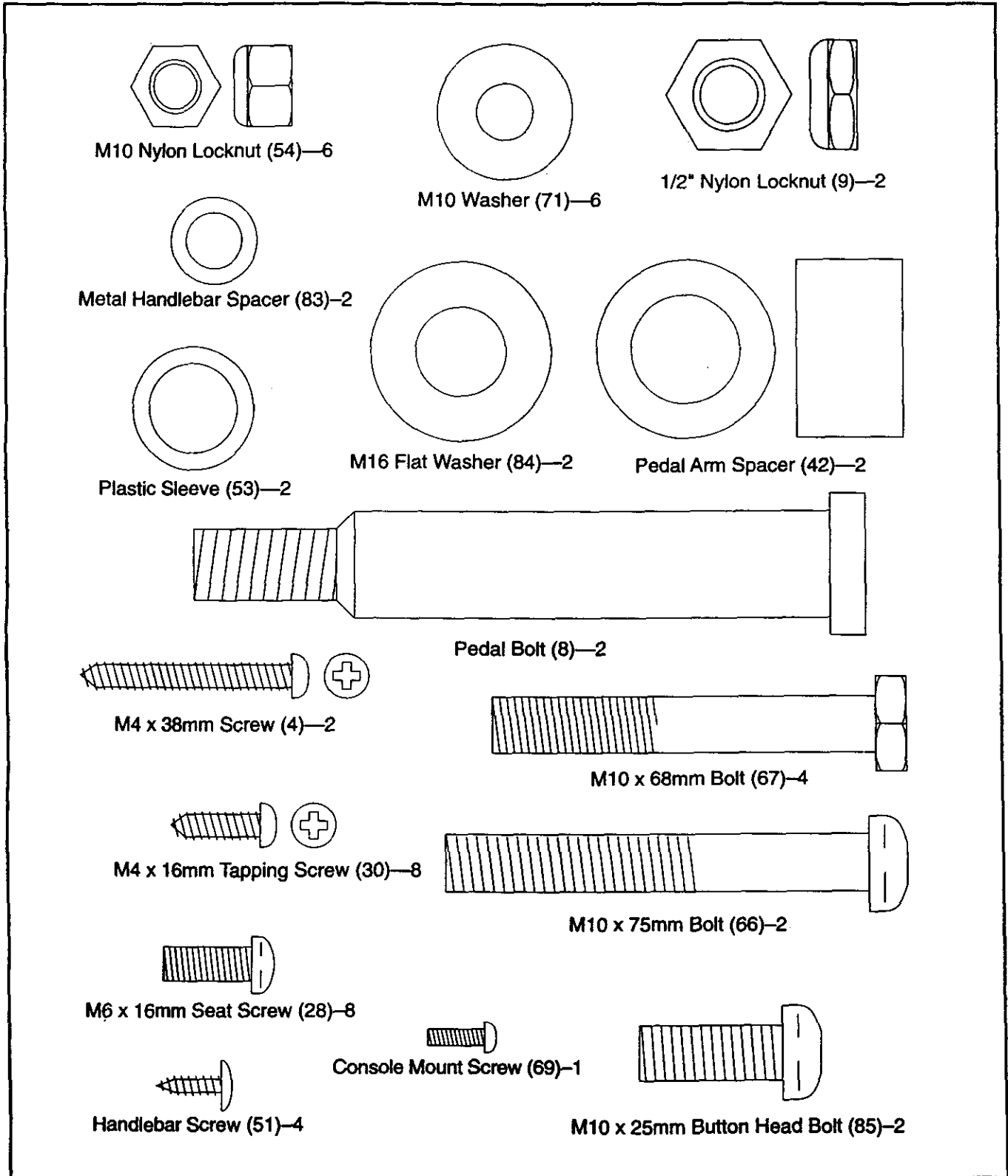

ASSEMBLY

Assembly requires two persons. Place all parts of the PROFORM® REBEL in a cleared area and remove the packing materials. Do not dispose of the packing materials until assembly is completed.

Assembly requires a phillips screwdriver , two adjustable wrenches  and a rubber mallet  (none of these are included).

1. Hold the Stabilizer (68) against the saddle on the back of the Base (1). Attach the Stabilizer with two M10 x 75mm Bolts (66) and two M10 Nylon Locknuts (54).

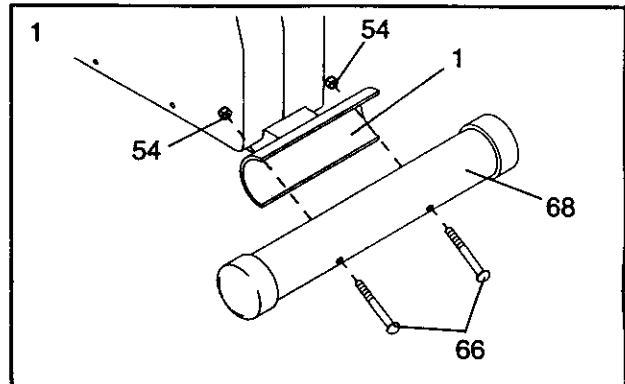

2. Slide the Rail Stabilizer (37) onto the Base (1), so the "U"-channel on the stabilizer fits into the Base. Make sure the Reed Switch Wire (48) is extending from the hole that will be formed as the two parts slide together. Make sure you don't damage the Reed Switch Wire when the two parts meet.

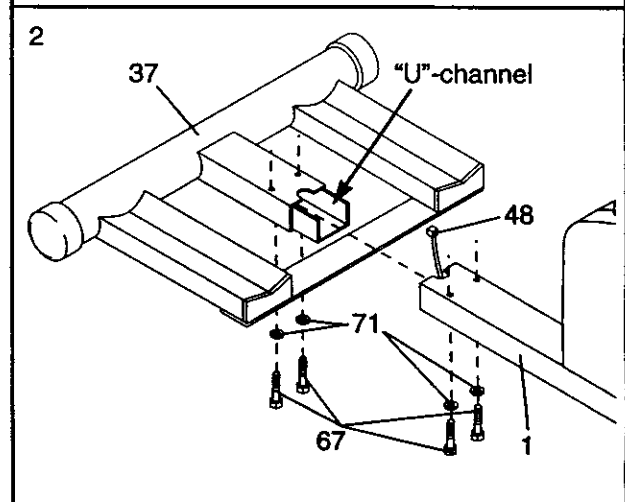

Insert two M10 x 68mm Bolts (67) with two M10 Washers (71) up through the Base (1).

Insert two M10 x 68mm Bolts (67) with two M10 Washers (71) up through the Rail Stabilizer (37).

Note: It may be easier to insert the four Bolts by tipping the unit on its side.

3. While one person holds the Upright (2), connect the Extension Wire (49) coming from the Upright to the Reed Switch Wire (48) extending from the Base (1). Stuff any excess wire into the Upright or into the Base (1).

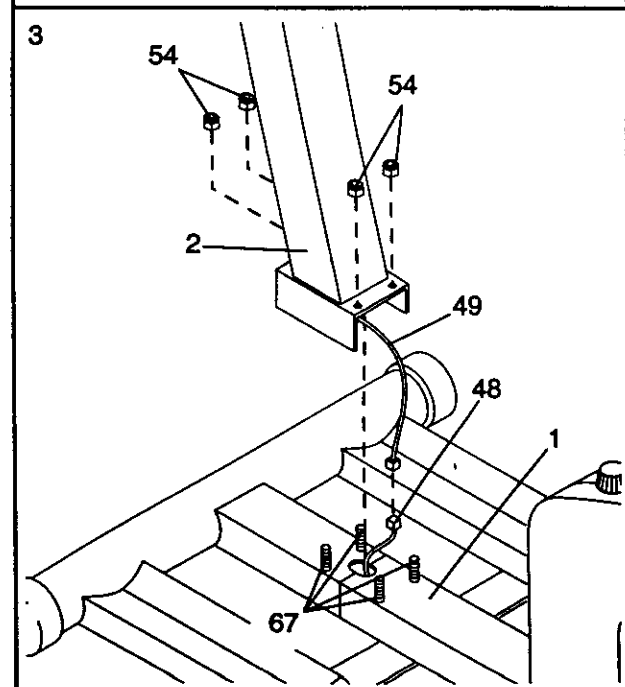

Slide the Upright (2) onto the four M10 x 68mm Bolts (67). Make sure you don't damage the wires as you slide the Upright into place.

Hand tighten an M10 Nylon Locknut (54) onto each M10 x 68mm Bolt (67). Tip the unit on its side and use two wrenches to tighten the Locknuts fully.

4. Connect the Seat Bar Wire (88) to the Handlebar Wire (87).

Slide the Handlebar (7) onto the Seat Bar (6) and attach it with the four Handlebar Screws (51). **Make sure you don't damage the two Wires as you tighten the Screws.**

Pull both Grips (72) towards the Handlebar (7) until they cover the Handlebar Screws (51).

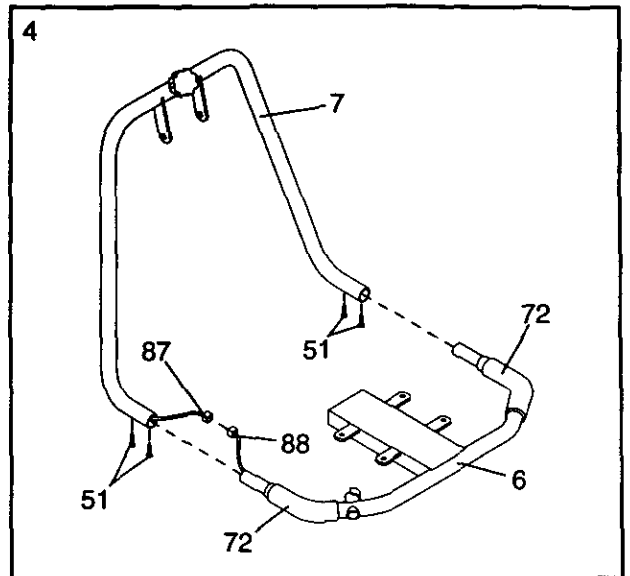

5. Unscrew the Console Mount Screw (69) and slide the Detent Ring (73) off the shaft on the Console (5).

Slide the console wire through the indicated hole in the Seat Bar (6).

Lubricate the shaft on the Console (5) with the included grease pack. Slide the shaft into the indicated hole in the Seat Bar (6).

Slide the Detent Ring (73) onto the console shaft and line up the hole in the Ring with the hole in the shaft. Secure the Console (5) with the Console Mount Screw (69). See the inset drawing for more detail.

Plug the console wire into the Seat Bar Wire (88).

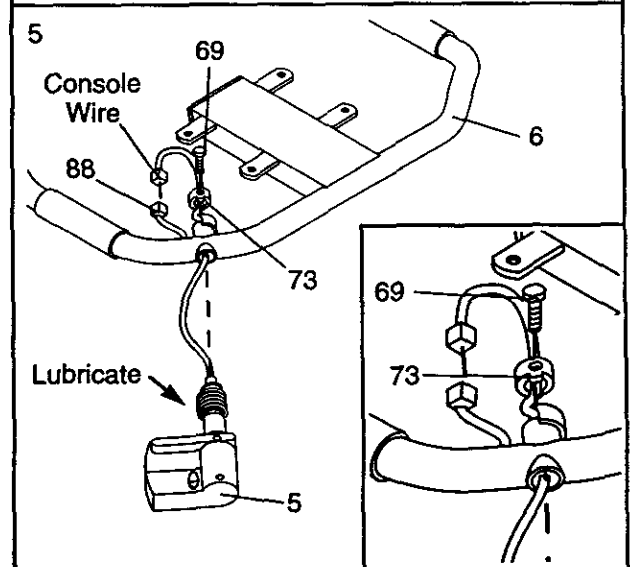

6. Attach the Seat (43) to the indicated brackets on the Seat Bar (6) with four M6 x 16mm Seat Screws (28).

Attach the Seat Cover (35) to the Seat (43), using two M4 x 38mm Screws (4) along the rear edge and an M4 x 16mm Tapping Screw (30) on each side.

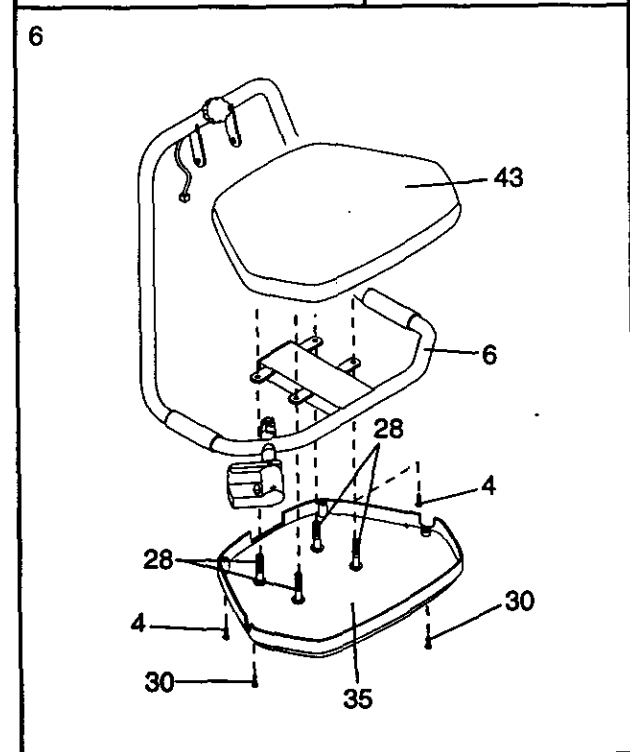

7. Plug the Extension Wire (49) that is coming out of the top of the Upright (2) into the Handlebar Wire (87) extending from the Handlebar (7).

Slide a Plastic Sleeve (53) onto each of the threaded shafts on the Upright (2) as shown.

Note: It will be easier to perform this step if one person holds the Handlebar in place while another tightens the Bolts. Attach the Handlebar (7) to the Upright (2) with the two M10 x 25mm Button Head Bolts (85). To do this, slide an M10 Washer (71) onto each Bolt. Slide the Bolts through the brackets on the Handlebar. Slide an M16 Flat Washer (84) onto each Bolt. Slide a Metal Handlebar Spacer (83) onto each Bolt. Slide the Bolts into the threaded holes in the Upright and tighten them with the included allen wrench.

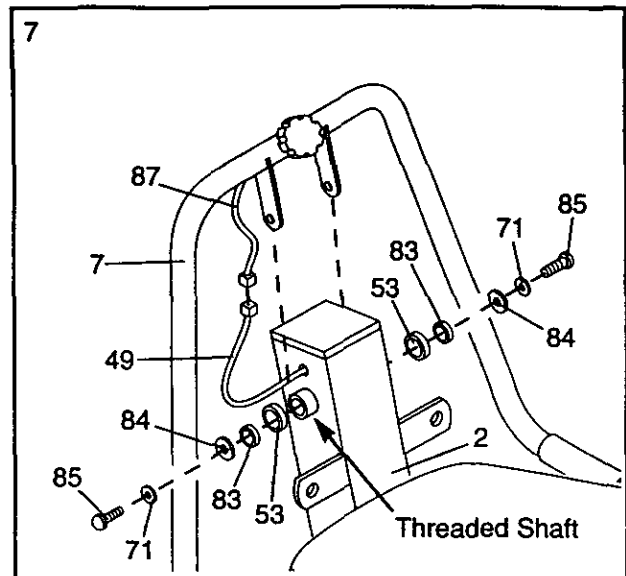

Do not overtighten the Button Head Bolts (85); it must be easy to pivot the Handlebar (7).

8. Attach the Backrest (40) to the indicated brackets on the Upright (2) with four M6 x 16mm Seat Screws (28).

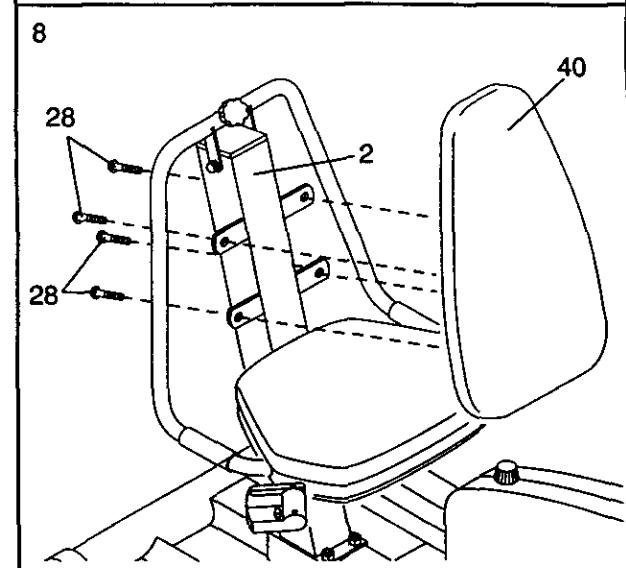

9. Identify the Left Pedal Leg (3) by looking at the Lock Pin (90) on the pre-assembled Toe Pedal (36). The Lock Pin must be on the outside when the Pedal Leg is mounted.

Attach a Pedal (29) to the Left Pedal Leg (3) with three M4 x 16mm Tapping Screws (30).

Lubricate a Pedal Bolt (8) with the included grease pack and slide it through the two pre-assembled Bushings (39). Slide a Plastic Pedal Spacer (42) onto the Pedal Bolt (8) and slide the Bolt into the hole in the left Crank Arm (10). Tighten a 1/2" Nylon Locknut (9) onto the Pedal Bolt (8).

Repeat this procedure for the Right Pedal Leg (70, not shown).

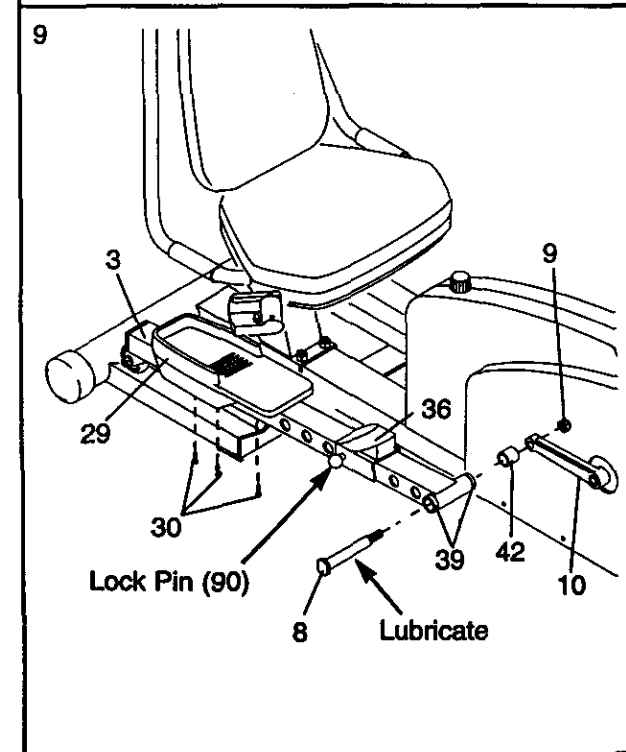

10. The Console (5) requires two "AA" batteries (not included). Alkaline batteries are recommended.

To install batteries, first slide up the battery cover and carefully remove the battery clip from the Console (5). Insert two batteries into the battery clip as shown. **Make sure that the negative ends of the batteries (marked "-") are touching the springs in the battery clip.** Replace the battery clip and close the battery cover.

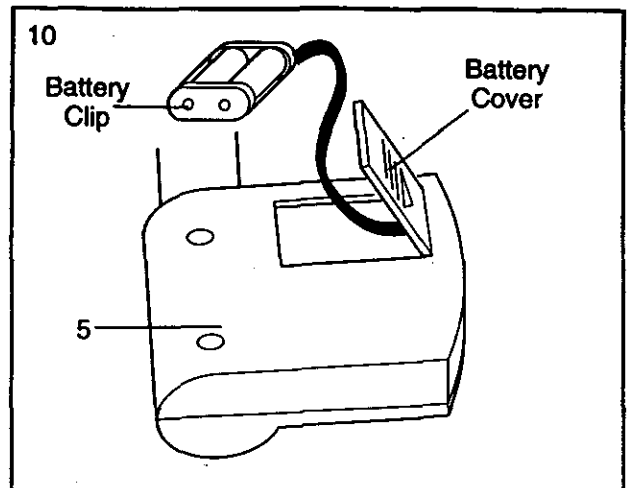

11. Make sure that all parts of the REBEL are properly tightened. To protect the floor or carpet from damage, place a mat under the REBEL.

HOW TO USE THE PROFORM® REBEL

HOW TO SWITCH BETWEEN RECUMBENT BIKE AND ELLIPTICAL CROSSTRAINER

To switch from recumbent bike to elliptical crosstrainer, lift the Seat (43) up as far as it will go. Tighten the Lock Knob (81, not visible) into the Upright (2). **Note: Tighten the Lock Knob fully.** Push the Console (5) in to dis-engage the lock, and then turn it so the display is visible when you are standing on the pedals.

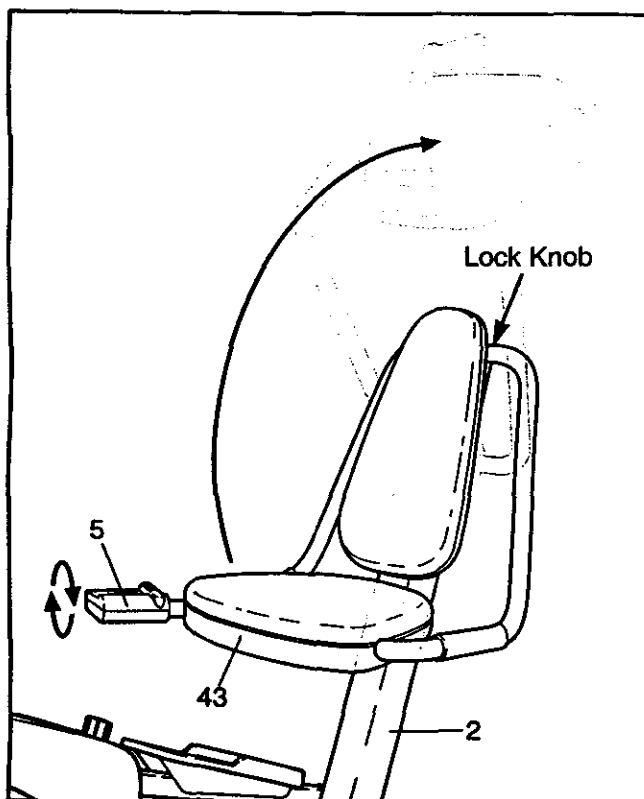

To switch from elliptical crosstrainer to recumbent bike, unscrew the Lock Knob (81, not visible). Fold the Seat (43) down and turn the Console (5) so it is visible when you are sitting on the Seat.

HOW TO EXERCISE ON THE REBEL WHEN IT IS SET UP AS AN ELLIPTICAL CROSSTRAINER

To mount the REBEL in the crosstrainer mode, hold the handlebars and step onto the pedal that is in the lowest position. Next, step onto the other pedal. Push the pedals until they begin to move with a continuous motion. **Note: The crank can turn in either direction. To get the full impact of the elliptical motion, it is recommended that you turn the crank in the direction shown by the arrow below; however, to give variety to your exercise, you may choose to turn the crank in the opposite direction.**

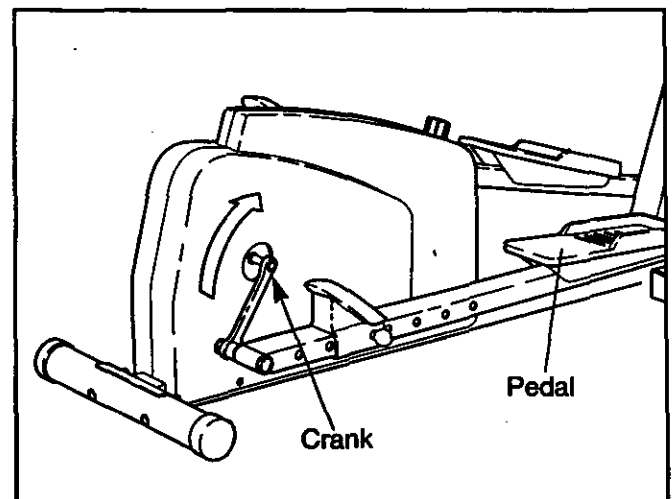

To dismount the REBEL, allow the pedals to slowly come to a stop. **CAUTION: The REBEL does not have a freewheel; the pedals will continue to move until the flywheel stops.** When the pedals are stationary, step off the highest pedal first. Then, step off the lowest pedal.

HOW TO ADJUST THE TOE PEDALS

To adjust the Right Toe Pedal (89), pull out the Lock Pin (90). Slide the Toe Pedal forwards or backwards to the desired location. Push the Lock Pin through the holes in the Toe Pedal and the adjustment holes in the Pedal Leg (70). Adjust the Left Pedal (36, not shown) in the same manner.

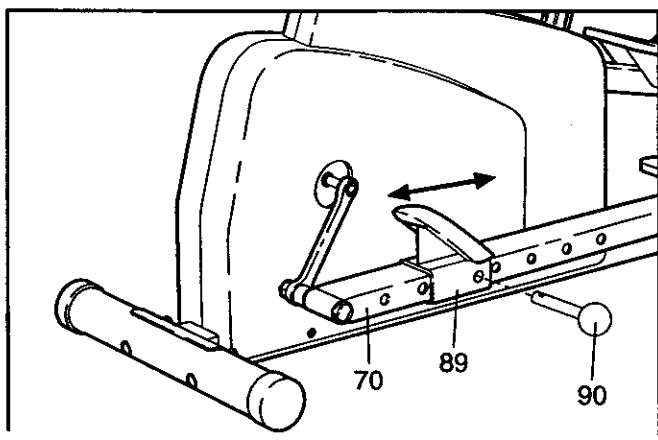

HOW TO ADJUST THE RESISTANCE OF THE PEDALS

As you exercise, you can adjust the resistance of the pedals with the resistance knob located as shown here. To increase the resistance, turn the knob clockwise; to decrease the resistance, turn the knob counter-clockwise.

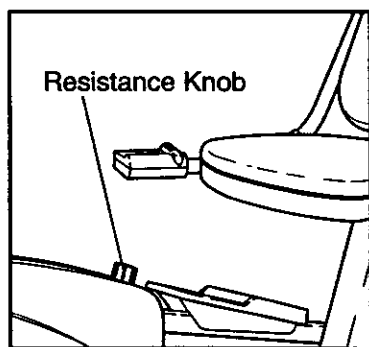

DESCRIPTION OF THE CONSOLE

The console is designed to help you get the most from your workouts. As you exercise, you can watch your progress as the display provides continuous exercise feedback. You can even measure your heart rate using the built-in pulse sensor. The modes of the display are described below. **Note: Before the console can be operated, two "AA" batteries must be installed (see assembly step 10 on page 8).**

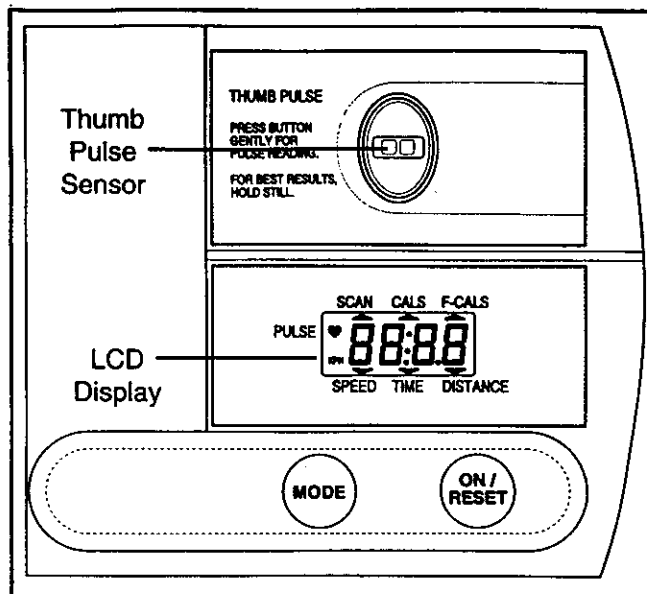

Speed—This mode displays your pedaling speed, in miles per hour.

Time—This mode displays the elapsed time. Note: When you stop exercising, the time mode will pause.

Distance—This mode displays the total distance you have pedaled, in miles.

Fat Calorie—This mode displays the approximate number of fat calories you have burned (see BURNING FAT on page 12).

Calorie—This mode displays the approximate number of Calories you have burned.

Scan—This mode displays the speed, time, distance, fat calorie and calorie modes, for 5 seconds each, in a repeating cycle.

Pulse—This mode displays your heart rate when the pulse sensor is used.

HOW TO OPERATE THE CONSOLE

If there is a thin sheet of clear plastic on the face of the console, remove it.

1. To turn on the power, press the on/reset button or simply begin pedaling. When the power is turned on, the entire display will appear for two seconds. The console will then be ready for operation.
2. Select one of the modes:

Scan mode—When the power is turned on, the scan mode will automatically be selected. One mode indicator will show that the scan mode is selected, and a flashing mode indicator will show

which mode is currently displayed. Note: If a different mode is selected, you can select the scan mode again by repeatedly pressing the mode button.

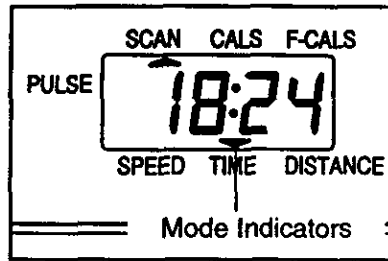

Speed, time, distance, fat calorie or calorie mode—To select one of these modes for continuous display, press the mode button repeatedly. The mode indicators will show which mode is selected. (Make sure that the scan mode is not selected.)

- To measure your pulse, stop pedaling and place your thumb on the pulse sensor as shown. The pulse sensor is pressure-activated—fully press down the pulse sensor. **Do not press too hard, or the circulation in your thumb will be restricted, and your pulse will not be detected.** Next, slightly raise your thumb until the heart-shaped indicator in the LCD display flashes **steadily**. Hold your thumb at this level. After 5 to 10 seconds, three dashes

will appear in the display and your pulse will be shown. Hold your thumb on the sensor for another 15 seconds for the most accurate reading. If the displayed pulse appears to be too high or too low, or if your pulse is not displayed, lift your thumb off the sensor and allow the display to reset. Press down again on the sensor as described above.

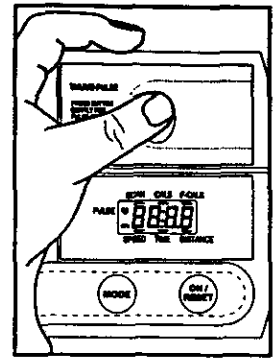

Make sure that your thumb is positioned as shown, and that you are applying the proper amount of pressure to the pulse sensor. Try the sensor several times until you become familiar with it.

- To reset the display, press the on/reset button.
- The console has an "auto-off" feature. If the pedals are not moved and the console buttons are not pressed for four minutes, the power will turn off automatically to conserve the batteries.

MAINTENANCE

CONSOLE TROUBLE-SHOOTING

If the console does not function properly, the batteries should be replaced. To replace the batteries, see assembly step 10 on page 8. In addition, make sure that the console wire is connected to the seat bar wire. See assembly step 5 on page 6.

HOW TO REMOVE THE SIDE SHIELDS

For all of the following steps, one or both Side Shields (11 and 27) must be removed.

To remove the Left Side Shield (11), unscrew the 1/2" Nylon Locknut (9) and remove the Pedal Bolt (8) and the Plastic Pedal Spacer (42) from the Left Pedal Leg (3). Unscrew the seven M4 x 38mm Screws (4) from the Left Side Shield. Gently pull the Left Side Shield out and to the side, so the Crank Arm (10) fits through the hole in the Side Shield.

To remove the Right Side Shield (27), first remove the Left Side Shield (11) as described above. Then

unscrew the three M4 x 38mm Screws (4) from the lower edge of the Right Side Shield. Remove the 1/2" Nylon Locknut (9), Pedal Bolt (8) and Plastic pedal Spacer (42) from the Right Pedal Leg (70, not shown). Gently pull the Right Side Shield over the Crank Arm.

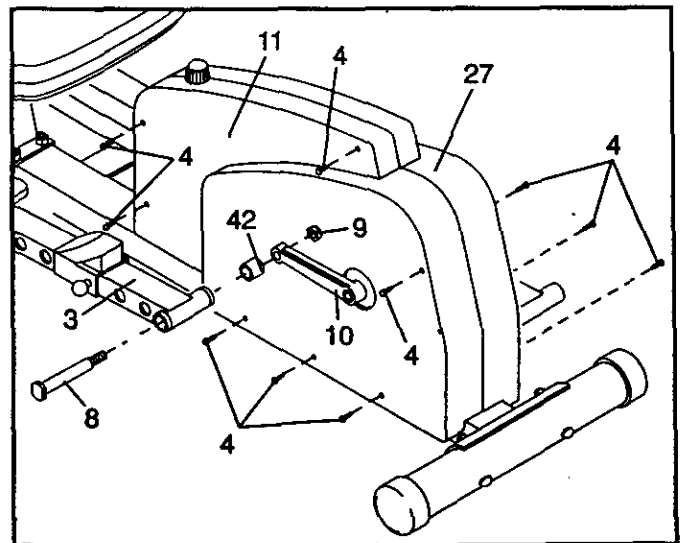

HOW TO ADJUST THE REED SWITCH

If the console does not display correct feedback, the reed switch should be adjusted. To adjust the reed switch, the Left Side Shield (11) must first be removed as described on page 10.

Next, locate the Reed Switch (48). Turn the Pulley (19) until the Magnet (55) is aligned with the Reed Switch. Loosen, but do not remove, the M4 x 12mm Screw (51, shown removed

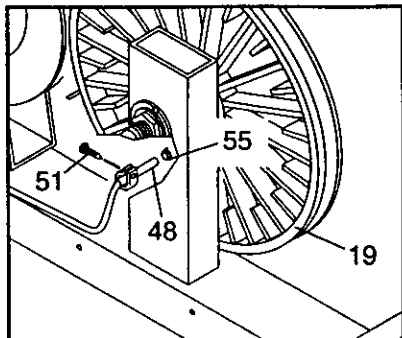

for clarity). Slide the Reed Switch slightly toward or away from the Magnet. Make sure that the Magnet will not hit the Reed Switch. Retighten the Screw. Turn the Pulley (19) for a moment. Repeat until the console displays correct feedback. When the Reed Switch is correctly adjusted, re-attach the Left Side Shield (11).

HOW TO ADJUST THE RESISTANCE STRAP

If the pedals do not have enough resistance, even when the resistance knob is turned to the maximum setting, the Resistance Strap (31) may need to be adjusted. To adjust the Resistance Strap, the Left Side

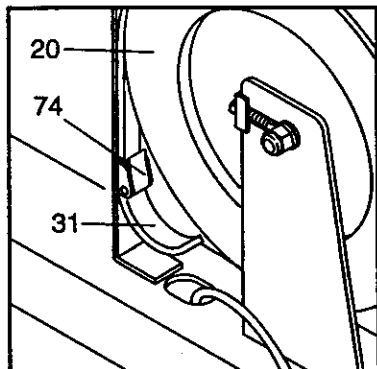

Shield (11, not shown) must first be removed, as described on page 10.

Turn the resistance knob to the lowest setting (see HOW TO ADJUST THE RESISTANCE OF THE PEDALS on page 9). Open the Buckle (74) and pull the end of the Resistance Strap (31) slightly downward. Close the Buckle and turn the Flywheel (20) to make sure that there is not too much resistance. When the Resistance Strap is properly adjusted, re-attach the Left Side Shield.

HOW TO ADJUST THE DRIVE BELT

If the Drive Belt (32) slips as you exercise on the REBEL, the Drive Belt should be adjusted. To adjust the Drive Belt, both Side Shields (11 and 27, not shown) must first be removed as described on page 10.

Next, loosen the two M8 Flange Nuts (23) (there is one on each side of the Flywheel (20)). To tighten the Drive Belt (32), turn the two M6 Nuts (26) clockwise; to loosen the Drive Belt, turn the M6 Nuts counterclockwise. Make sure that the Flywheel is straight and retighten the M8 Flange Nuts (23). When the Drive Belt is properly adjusted, re-attach the Side Shields.

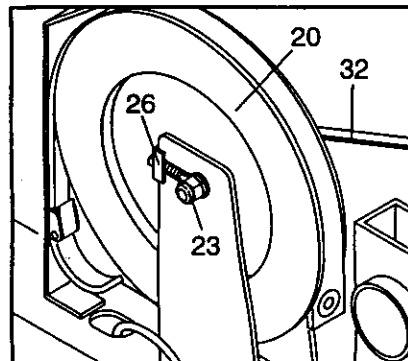

HOW TO TIGHTEN THE CRANK

If the Crank Arms (10) become loose, they should be tightened in order to prevent excessive wear. To tighten the Crank Arms, the Left Side Shield (11, not shown) must first be removed as described on page 10.

Next, loosen the Crank Nut (17) on the left Crank Arm (10). Place the end of a standard screwdriver in one of the slots in the Slotted Crank Nut (15). Lightly tap the screwdriver with a hammer to turn the Slotted Crank Nut counterclockwise until the arms are no longer loose. **Do not overtighten the Slotted Crank Nut.** When the Slotted Crank Nut is properly tightened, retighten the Crank Nut and re-attach the Left Side Shield.

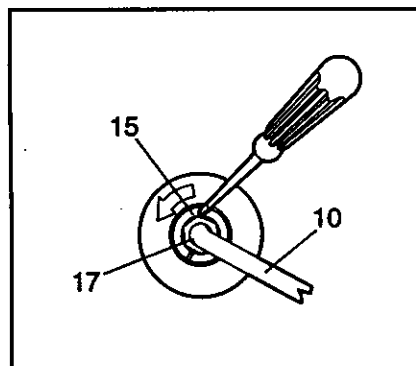

CONDITIONING GUIDELINES

The following guidelines will help you to plan your exercise program. Remember that proper nutrition and adequate rest are essential for successful results.

WARNING: Before beginning this or any exercise program, consult your physician. This is especially important for individuals over the age of 35 or individuals with pre-existing health problems.

WARNING: The pulse sensor is not a medical device. Various factors, including the user's movement, may affect the accuracy of heart rate readings. The pulse sensor is intended only as an exercise aid in determining heart rate trends in general.

WHY EXERCISE?

Exercise has proven essential for good health and well-being. Participation in a well-rounded exercise program helps to develop a stronger and more efficient heart, improved respiratory function, increased stamina, better weight management, increased ability to handle stress, and greater self-esteem.

EXERCISE INTENSITY

Whether your goal is to burn fat or to strengthen your cardiovascular system, the key to achieving the desired results is to exercise with the proper intensity.

AGE	TRAINING ZONE (BEATS/MIN.)	
	UNCONDITIONED	CONDITIONED
20	138-167	133-162
25	136-166	132-160
30	135-164	130-158
35	134-162	129-156
40	132-161	127-155
45	131-159	125-153
50	129-156	124-150
55	127-155	122-149
60	126-153	121-147
65	125-151	119-145
70	123-150	118-144
75	122-147	117-142
80	120-146	115-140
85	118-144	114-139

The proper intensity level can be found by using your heart rate as a guide. For effective exercise, your heart rate should be maintained at a level between 70% and 85% of your maximum heart rate as you exercise. This is known as your training zone. You can find your training zone in the table below. Training zones are listed according to age and physical condition.

Burning Fat

To burn fat effectively, you must exercise at the proper intensity level for a sustained period of time. During the first few minutes of exercise, your body uses easily accessible *carbohydrate* calories for energy. Only after the first few minutes does your body begin to use stored *fat* calories for energy. If your goal is to burn fat, keep your heart rate in the lower end of your training zone.

Aerobic Exercise

If your goal is to strengthen your cardiovascular system, your exercise must be "aerobic." Aerobic exercise is activity that requires large amounts of oxygen for prolonged periods of time. This increases the demand on the heart to pump blood to the muscles, and on the lungs to oxygenate the blood. For effective aerobic exercise, keep your heart rate in the higher end of your training zone.

HOW TO MEASURE YOUR HEART RATE

To measure your heart rate, follow the procedure described on page 10.

WORKOUT GUIDELINES

A proper workout includes the following parts:

A warm-up, consisting of 5 to 10 minutes of stretching and light exercise. A proper warm-up increases the body temperature, heart rate, and circulation in preparation for exercise.

A cardiovascular exercise period, including 20 to 30 minutes of exercise with your heart rate in your training zone.

A cool-down, with 5 to 10 minutes of stretching. Thorough stretching helps to offset problems caused when you stop exercising suddenly. Stretching after exercise is also very effective for increasing flexibility.

EXERCISE FREQUENCY

To maintain or improve your condition, plan three workouts each week, with at least one day of rest between workouts. After a few months of regular

exercise, you may complete up to five workouts each week, if desired. Find the best time of day for your workouts, and then stick with it.

SUGGESTED STRETCHES

The correct form for several basic stretches is shown at the right. Move slowly as you stretch—never bounce.

1. Toe Touch Stretch

Stand with your knees bent slightly and slowly bend forward from your hips. Allow your back and shoulders to relax as you reach down toward your toes as far as possible. Hold for 15 counts, then relax. Repeat 3 times. Stretches: Hamstrings, back of knees and back.

2. Hamstring Stretch

Sit with one leg extended. Bring the sole of the opposite foot toward you and rest it against the inner thigh of your extended leg. Reach toward your toes as far as possible. Hold for 15 counts, then relax. Repeat 3 times for each leg. Stretches: Hamstrings, lower back and groin.

3. Calf/Achilles Stretch

With one leg in front of the other, reach forward and place your hands against a wall. Keep your back leg straight and your back foot flat on the floor. Bend your front leg, lean forward and move your hips toward the wall. Hold for 15 counts, then relax. Repeat 3 times for each leg. To cause further stretching of the achilles tendons, bend your back leg as well. Stretches: Calves, achilles tendons and ankles.

4. Quadriceps Stretch

With one hand against a wall for balance, reach back and grasp one foot with your other hand. Bring your heel as close to your buttocks as possible. Hold for 15 counts, then relax. Repeat 3 times for each leg. Stretches: Quadriceps and hip muscles.

5. Inner Thigh Stretch

Sit with the soles of your feet together and your knees outward. Pull your feet toward your groin area as far as possible. Hold for 15 counts, then relax. Repeat 3 times. Stretches: Quadriceps and hip muscles.

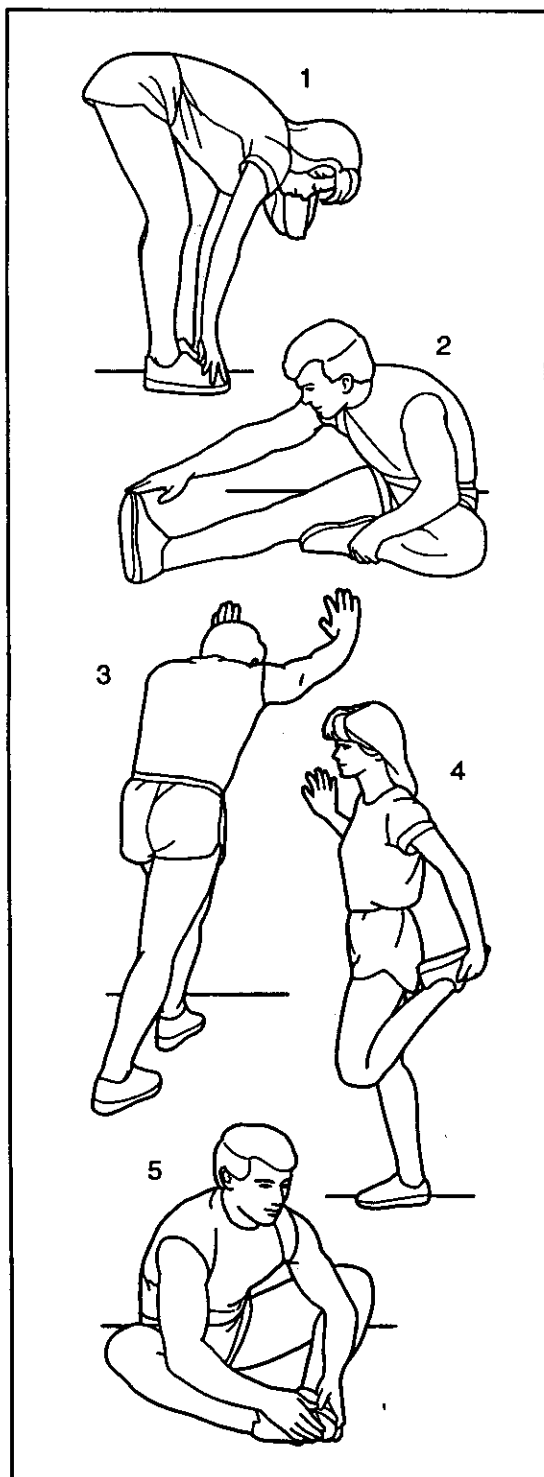

PART LIST—MODEL No. 831.285870

R1298A

Key No.	Qty.	Description	Key No.	Qty.	Description
1	1	Base	47	4	Stabilizer Endcap
2	1	Upright	48	1	Reed Switch/Sensor Wire
3	1	Left Pedal Leg	49	1	Extension Wire
4	12	M4 x 38mm Screw	50	1	Reed Switch Clip
5	1	Console	51	4	Handlebar Screw
6	1	Seat Bar	52	1	M4 x 16mm Flat Head Screw
7	1	Handlebar	53	2	Plastic Sleeve
8	2	Pedal Bolt	54	6	M10 Nylon Locknut
9	2	1/2" Nylon Locknut	55	1	Magnet
10	2	Crank Arm	56	1	Clamp Bolt
11	1	Left Side Shield	57	4	1/4" Flat Washer
12	2	Crank Bearing	58	1	1/4" Nylon Locknut
13	2	Bearing Cup	59	1	Resistance Strap Hook
14	1	Keyed Washer	60	2	Console Washer
15	1	Slotted Crank Nut	61	2	Flywheel Bearing
16	1	Tri-notch Crank Nut	62	2	Crank Cover
17	2	Crank Nut	63	1	Seat Cap
18	2	5/16" x 3/4" Tap Screw	64	1	Bearing Washer
19	1	Pulley	65	2	Crank Washer
20	1	Flywheel w/Hub	66	2	M10 x 75mm Bolt
21	1	Flywheel Axle	67	4	M10 x 68mm Bolt
22	3	M10 Flat Washer	68	1	Stabilizer
23	2	M10 Nut	69	3	Console Mount Screw
24	2	M6 Eyebolt	70	1	Right Pedal Leg
25	2	Adjustment Bracket	71	6	M10 Washer
26	2	M6 Nut	72	2	Grip
27	1	Right Side Shield	73	1	Detent Ring
28	8	M6 x 16mm Seat Screw	74	1	Buckle
29	2	Pedal	75	2	M8 x 57mm Bolt
30	9	M4 x 16mm Tapping Screw	76	4	M8 Washer
31	1	Resistance Strap	77	4	Metal Wheel Spacer
32	1	Drive Belt	78	4	Wheel Bearing
33	1	Resistance Cable w/Spring	79	2	Pedal Wheel
34	1	Resistance Knob	80	2	M8 Nylon Locknut
35	1	Seat Cover	81	1	Lock Knob
36	1	Left Toe Pedal	82	1	Upright Cap
37	1	Rail Stabilizer	83	2	Metal Handlebar Spacer
38	2	Rail Endcap	84	2	M16 Flat Washer
39	4	Bushing	85	2	M10 x 25mm Button Head Bolt
40	1	Backrest	86	1	Allen Wrench
41	1	Small Spring	87	1	Handlebar Wire
42	2	Plastic Pedal Spacer	88	1	Seat Bar Wire
43	1	Seat	89	1	Right Toe Pedal
44	2	1 1/2" x 2 1/2" Inner Cap	90	2	Lock Pin
45	1	Console Axle	#	1	Grease Pack
46	1	Console Spring	#	1	User's Manual

Note: "#" indicates a non-illustrated part. Specifications are subject to change without notice. See the back cover of this manual for information about ordering replacement parts.

15

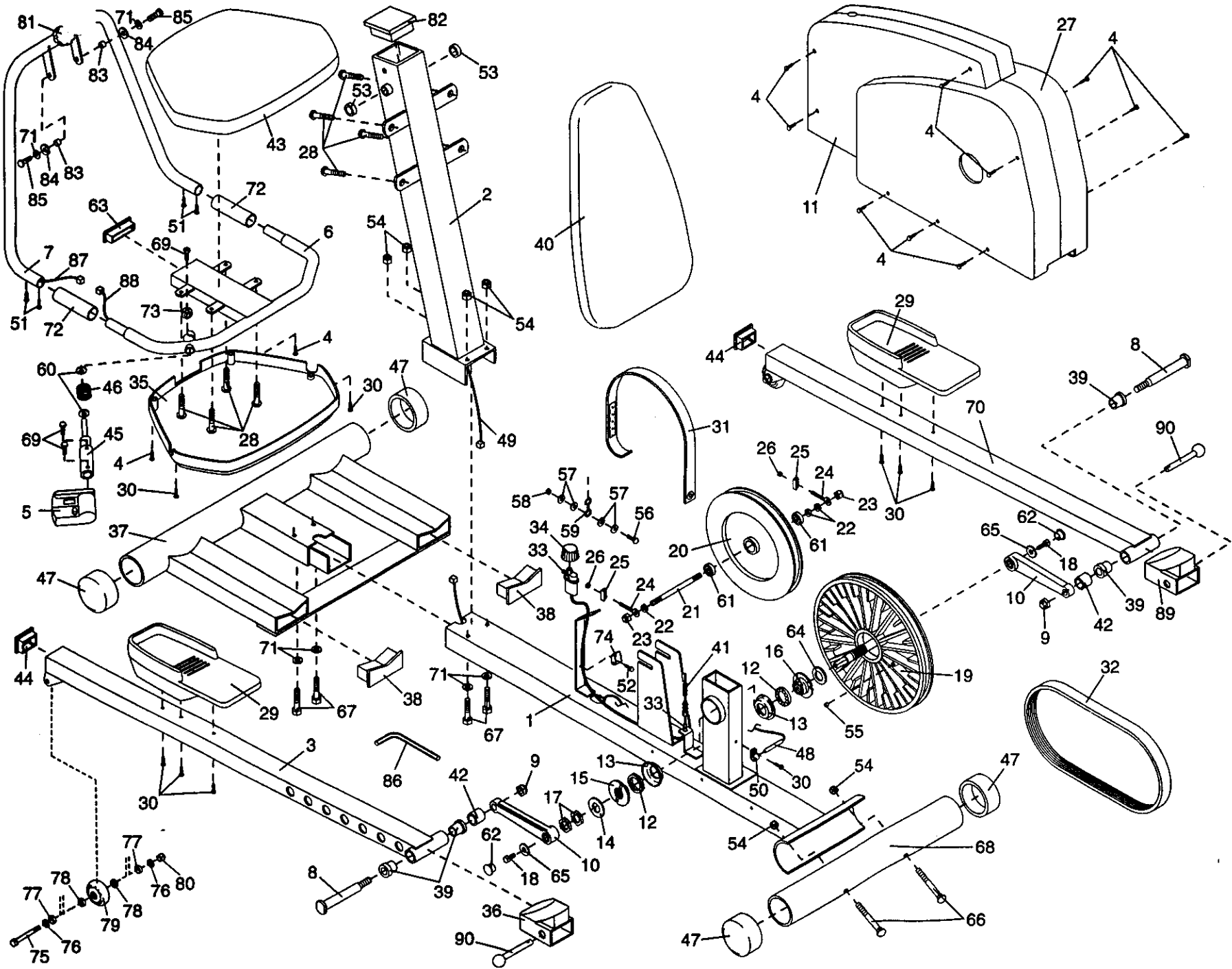

EXPLODED DRAWING—Model No. 831.285870

R1298A

ORDERING REPLACEMENT PARTS

SEARS

QUESTIONS?

If you find that:

- you need help assembling or operating the PROFORM® REBEL Recumbent Bike and Elliptical Crosstrainer
- a part is missing
- or you need to schedule repair service

call our toll-free HELPLINE

1-800-736-6879

Monday–Saturday, 7 am–7 pm
Central Time (excluding holidays)

REPLACEMENT PARTS

If parts become worn and need to be replaced, call the following toll-free number

1-800-FON-PART (366-7278)

The model number and serial number of your PROFORM® REBEL Recumbent Bike and Elliptical Crosstrainer are listed on a decal attached to the frame. See the front cover of this manual to find the location of the decal.

All replacement parts are available for immediate purchase or special order when you visit your nearest SEARS Service Center. To request service or to order parts by telephone, call the toll-free numbers listed at the left.

When requesting help or service, or ordering parts, please be prepared to provide the following information:

- The MODEL NUMBER of the product (831.285870).
- The NAME of the product (PROFORM® REBEL Recumbent Bike and Elliptical Crosstrainer).
- The KEY NUMBER and DESCRIPTION of the PART (see pages 14 and 15).

FULL 90 DAY WARRANTY

For 90 days from the date of purchase, if failure occurs due to defect in material or workmanship in this SEARS EXERCISER, contact the nearest SEARS Service Center throughout the United States and SEARS will repair or replace the EXERCISER, free of charge.

This warranty does not apply when the EXERCISER is used commercially or for rental purposes.

This warranty gives you specific legal rights, and you may also have other rights which vary from state to state.

SEARS, ROEBUCK AND CO., DEPT. 817WA, HOFFMAN ESTATES, IL 60179

PROFORM is a registered trademark of ICON Health & Fitness, Inc.