

LOW IMPACT ELLIPTICAL EXERCISER

485E

Patent Pending

Model No. 831.285735

Serial No. _____

Write the serial number in the space above for future reference.

Serial
Number
Decal

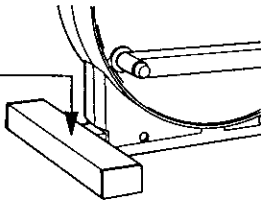

EXERCISE
EQUIPMENT

QUESTIONS

HELPLINE!

1-800-736-6879



CAUTION

Read all precautions and instructions in this manual before using this equipment. Keep this manual for future reference.

USER'S MANUAL

SEARS, ROEBUCK AND CO., HOFFMAN ESTATES, IL 60179



TABLE OF CONTENTS

IMPORTANT PRECAUTIONS	3
BEFORE YOU BEGIN	4
PART IDENTIFICATION CHART	5
ASSEMBLY	6
HOW TO USE THE PROFORM® 485E	9
MAINTENANCE	11
CONDITIONING GUIDELINES	12
PART LIST	14
EXPLODED DRAWING	15
HOW TO ORDER REPLACEMENT PARTS	Back Cover
FULL 90 DAY WARRANTY	Back Cover

IMPORTANT PRECAUTIONS

WARNING: To reduce the risk of serious injury, read the following important precautions before using the PROFORM® 485E.

1. Read all instructions in this manual before using the 485E.
2. Use the 485E only as described in this manual.
3. It is the responsibility of the owner to ensure that all users of the 485E are adequately informed of all precautions.
4. Place the 485E on a level surface, with a mat beneath it to protect the floor or carpet. Keep the 485E indoors, away from moisture and dust.
5. Inspect and tighten all parts regularly. Replace any worn parts immediately.
6. Keep children under the age of 12 and pets away from the 485E at all times.
7. The 485E should not be used by persons weighing more than 250 pounds.
8. Wear appropriate clothing when using the 485E. Always wear athletic shoes for foot protection.
9. When mounting and dismounting the 485E, always hold the handlebars or the T-handle and step onto and off the pedal that is in the lowest position.
10. Each time you stop exercising on the 485E, allow the pedals to come to a complete stop before dismounting.
11. Always keep your back straight when using the 485E. Do not arch your back.
12. If you feel pain or dizziness at any time while exercising, stop immediately and begin cooling down.
13. The 485E is intended for in-home use only. Do not use the 485E in a commercial, rental, or institutional setting.

WARNING: Before beginning this or any exercise program, consult your physician. This is especially important for persons over the age of 35 or persons with pre-existing health problems. Read all instructions before using. SEARS assumes no responsibility for personal injury or property damage sustained by or through the use of this product.

The decal shown at the right has been placed on the 485E. If the decal is missing, or if it is not legible, please call our toll-free HELPLINE at 1-800-736-6879 to order a free replacement decal. Apply the decal in the location shown.

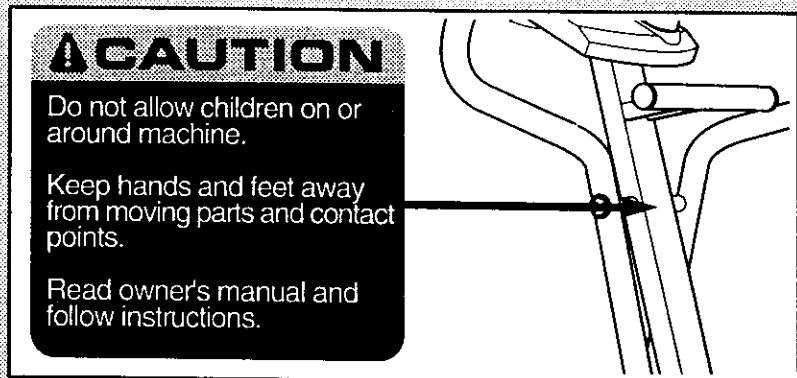

BEFORE YOU BEGIN

Congratulations for selecting the PROFORM® 485E low-impact elliptical exerciser. The 485E is an incredibly smooth exerciser that moves your feet in a natural elliptical path, minimizing the impact on your knees and ankles. And the unique 485E features adjustable resistance, upper-body and stationary handlebars, and a multi-mode exercise monitor to help you get the most from your exercise. Welcome to a whole new world of natural, elliptical-motion exercise from PROFORM.

For your benefit, read this manual carefully before you use the PROFORM® 485E. If you have additional

questions, please call our toll-free HELPLINE at 1-800-736-6879, Monday through Saturday, 7 a.m. until 7 p.m. Central Time (excluding holidays). To help us assist you, please note the product model number and serial number before calling. The model number is 831.285735. The serial number can be found on a decal attached to the 485E (see the front cover of this manual for the location of the decal).

Before reading further, please look at the drawing below and familiarize yourself with the parts that are labeled.

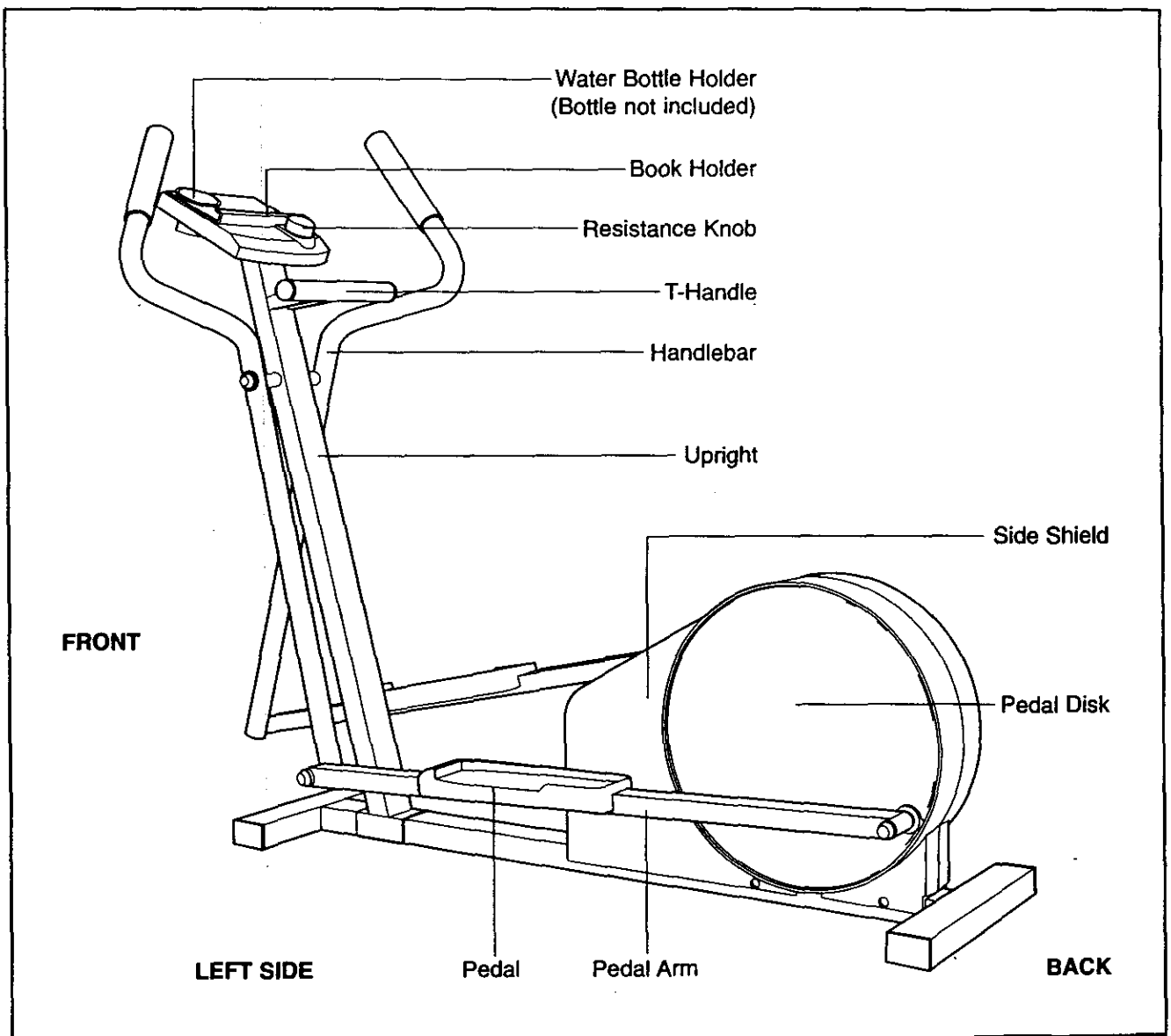

PART IDENTIFICATION CHART

Use the chart below to identify the small parts used in assembly. The number in parenthesis below each part is the key number of the part, from the PART LIST on page 14. The number after the dash indicates the

quantity needed for assembly. **Note: Some small parts may have been pre-attached for shipping. If a part is not in the parts bag, check to see if it has been pre-attached.**

<p>Handlebar Spacer (39)—2</p>	<p>1/4" x 3/4" Screw (54)—2</p>	<p>#8 x 3/4" Round Head Screw (16)—10</p>
	<p>1/4" Black Nylon Locknut (55)—2</p>	<p>3/8" Nylon Locknut (29)—4</p>
<p>Weld Spacer (49)—2</p>	<p>3/4" Axle Cap (43)—4*</p>	<p>5/8" Axle Cap (57)—2*</p>
<p>Pedal Arm Spacer (41)—3*</p>	<p>Pedal Arm Bushing (42)—4</p>	<p>Pivot Bushing (56)—4*</p>
		<p>Rear Pedal Arm Bushing (11)—4</p>

Extra parts may be included.

ASSEMBLY

Assembly requires two people. Place all parts of the PROFORM® 485E in a cleared area and remove the packing materials. Do not dispose of the packing materials until assembly is completed.

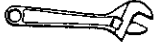
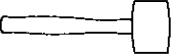
Assembly requires a phillips screwdriver  , two adjustable wrenches  , and a rubber mallet .

1. Feed the console wire down through the Upright (3) as shown. While another person holds the Upright near the Frame (1), tie the console wire and the Sensor Wire (25) together as shown in drawing 1a. Next, connect the console wire to the Sensor Wire.

Gently pull the Resistance Cable (26) and the console wire out of the top of the Upright (3) until there is no slack between the Upright and the Frame (1).

Slide the Upright (3) onto the welded bolts on the Frame (1). **Be careful to avoid pinching the Resistance Cable (26) and the Sensor Wire (25).** Tighten a 3/8" Nylon Locknut (29) onto each welded bolt.

2. Feed the console wire back down into the Upright (3). Attach the Console (6) to the Upright with four #8 x 3/4" Round Head Screws (16). **Be careful to avoid pinching the console wire.**

Press the Resistance Knob (50) onto the Resistance Control (26).

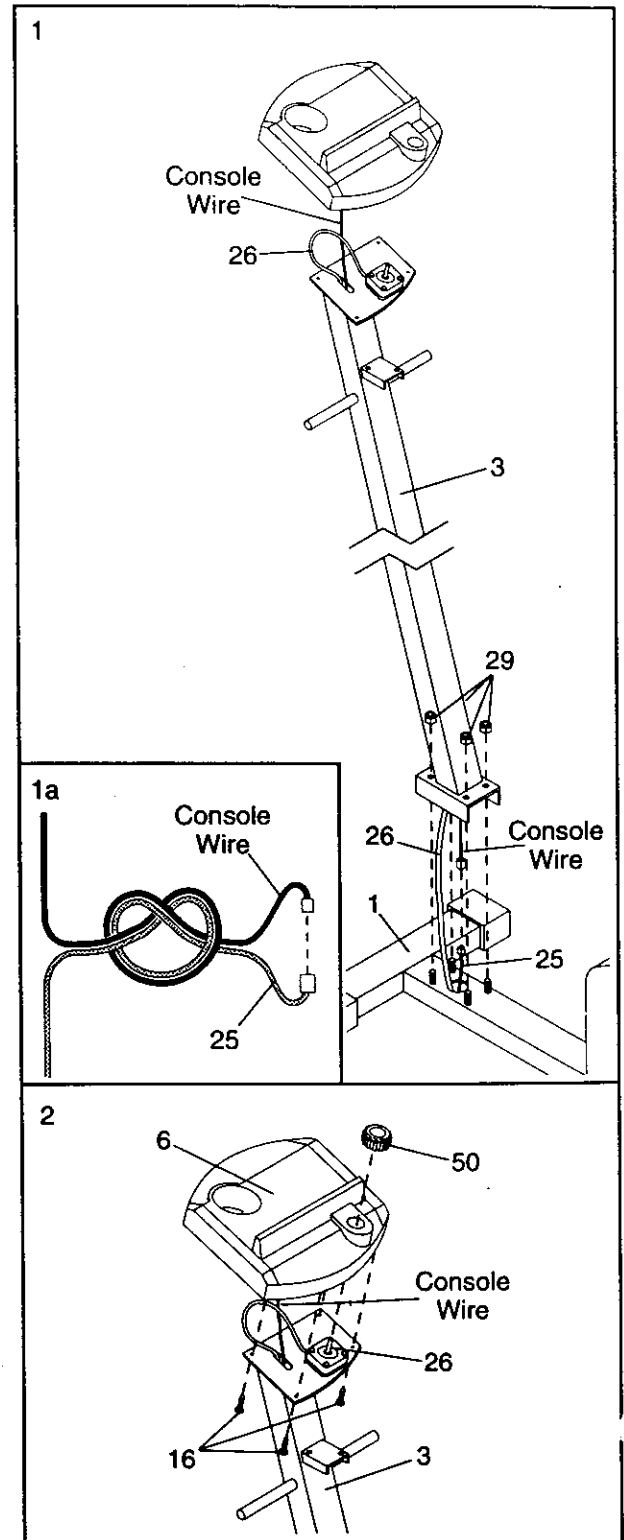

3. Find the Left Pedal (31), which has a ridge on the right side. Attach the Left Pedal to one of the Pedal Arms (12) with three #8 x 3/4" Round Head Screws (16) as shown.

Repeat this step to attach the Right Pedal to the other Pedal Arm (not shown).

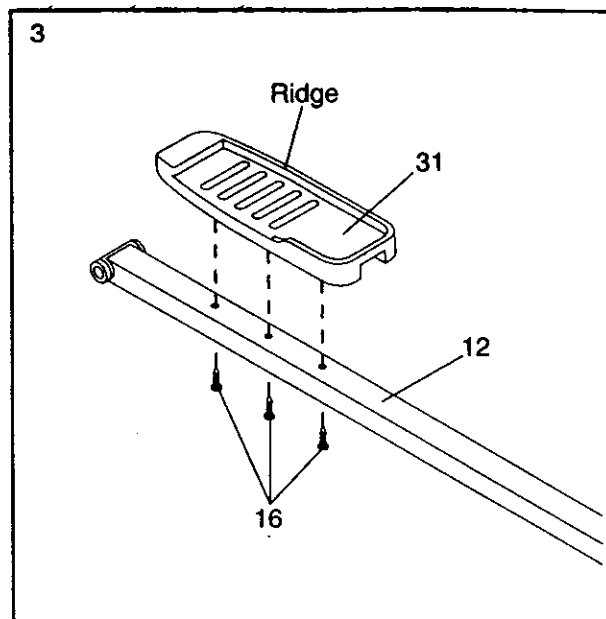

4. Make sure that there are two Pedal Arm Bushings (42) in each Pedal Arm (12).

Slide a Handlebar Spacer (39) and the Pedal Arm (12) with the Left Pedal (31) onto a Handlebar (8) as shown. (Note: These parts fit tightly; it may be helpful to use the rubber mallet). Refer to the PART IDENTIFICATION CHART on page 5 and identify the 3/4" Axle Caps (43). Tap a 3/4" Axle Cap onto the Handlebar.

Repeat this step to attach the other Pedal Arm (12) to the other Handlebar (8).

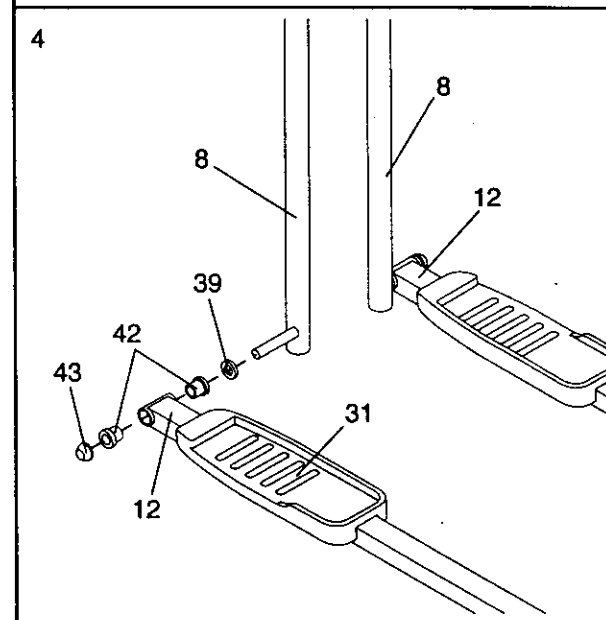

5. Make sure that there are two Rear Pedal Arm Bushings (11) in each Pedal Arm (12).

Slide a Pedal Arm Spacer (41) and the left Pedal Arm (12) onto the left Crank Arm (59) (these parts fit tightly; it may be helpful to use the rubber mallet). **Be careful not to confuse the left Pedal Arm with the right Pedal Arm (not shown); look at the position of the left Handlebar (8) to identify the left Pedal Arm.**

Tap a 3/4" Axle Cap (43) onto the left Crank Arm (59).

Repeat this step to attach the right Pedal Arm (not shown).

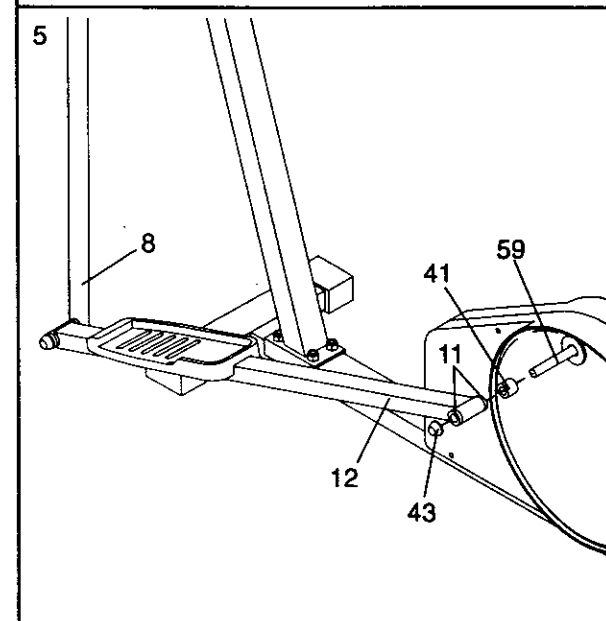

6. Refer to drawing 6a. Push the left Pedal Arm (12) until the left Crank Arm (59) is at the back of the Side Shields (4, 5) as shown.

Slide a Weld Spacer (49) and a Pivot Bushing (56) onto the left axle on the Upright (3). Make sure that the open side of the Weld Spacer is facing the Upright and that the Pivot Bushing is turned as shown.

Slide the left Handlebar (8) onto the left axle on the Upright (3). Make sure that the Handlebar slides onto the Pivot Bushing (56) on the axle. Slide another Pivot Bushing (56) onto the axle and start it into the Handlebar. Using a rubber mallet and the extra Pedal Arm Spacer (41, not shown), tap the Pivot Bushing into the Handlebar. Remove the Pedal Arm Spacer.

Tap a 5/8" Axle Cap (57) onto the axle.

Repeat this step to attach the right Handlebar (not shown).

7. Attach the T-Handle (10) to the Upright (3) with two 1/4" x 3/4" Screws (54) and two 1/4" Black Nylon Locknuts (55).

8. The Console (6) requires two "AA" batteries (not included). Alkaline batteries are recommended.

To install batteries, first locate the battery clip under the Console (6). Insert two batteries into the battery clip as shown. **Make sure that the batteries are turned so the negative ends of the batteries (marked "-") are touching the springs in the battery clip.**

9. **Make sure that all parts of the 485E are properly tightened.** Place a mat under the 485E to protect the floor or carpet from damage.

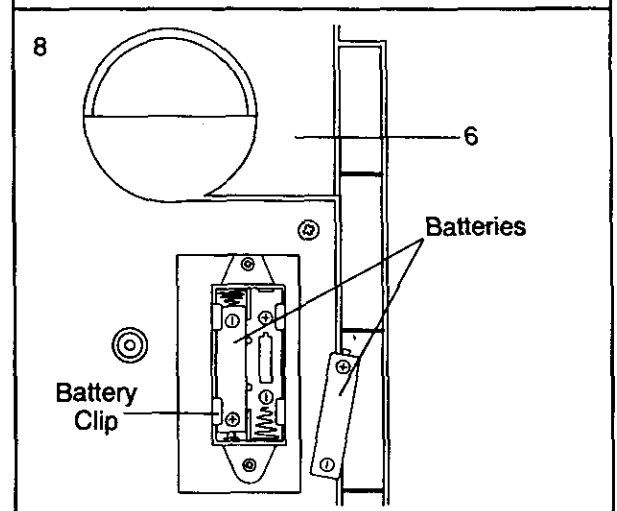
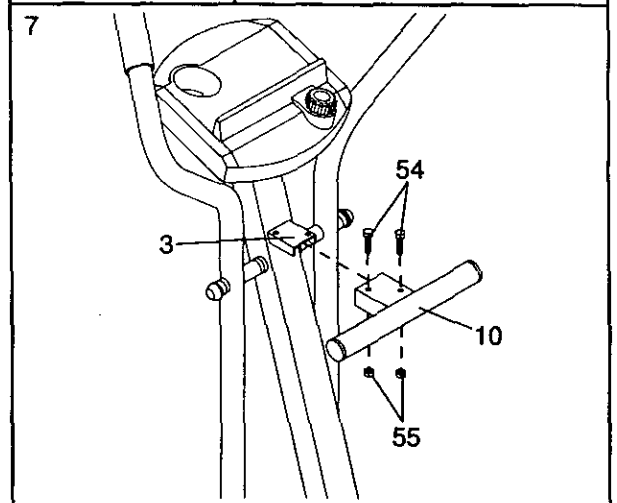
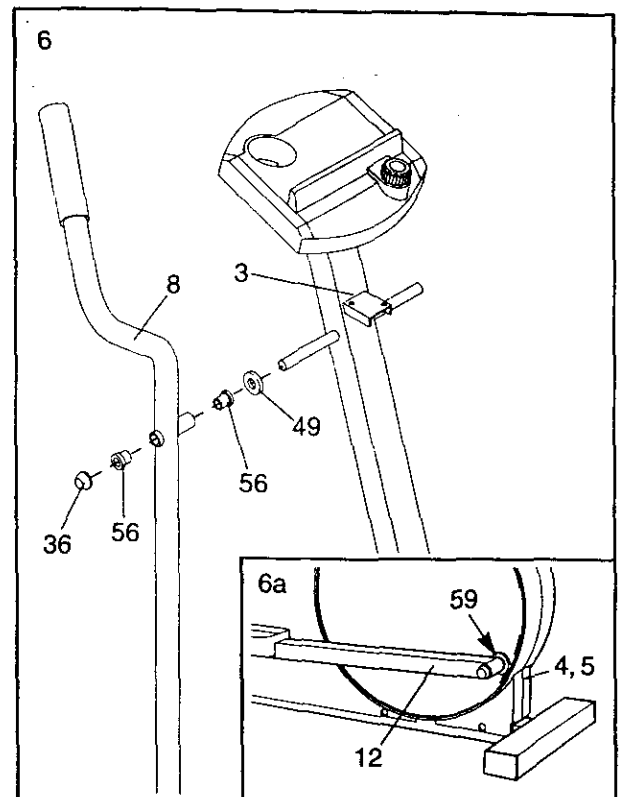

HOW TO USE THE PROFORM® 485E

HOW TO EXERCISE ON THE 485E

To mount the 485E, firmly hold the handlebars or the T-handle and carefully step onto the pedal that is in the lowest position. Next, step onto the other pedal. Push the pedals until they begin to move with a continuous motion. **Note: The pedal disks can turn in either direction; it is recommended that you turn the pedal disks in the direction shown below; however, to give variety to your exercise, you may choose to turn the pedal disks in the opposite direction.**

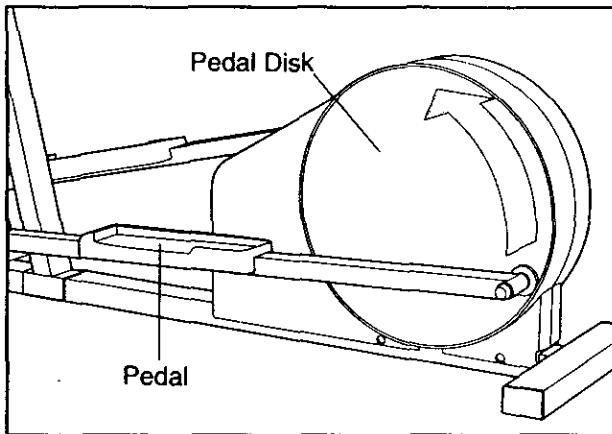

To dismount the 485E, allow the pedals to come to a complete stop. **CAUTION: The 485E does not have a freewheel; the pedals will continue to move until the flywheel stops.** When the pedals are stationary, step off the highest pedal first. Then, step off the lowest pedal.

HOW TO ADJUST THE RESISTANCE OF THE PEDALS

As you exercise, you can adjust the resistance of the pedals with the resistance knob on the console. To increase the resistance, turn the knob clockwise; to decrease the resistance, turn the knob counterclockwise.

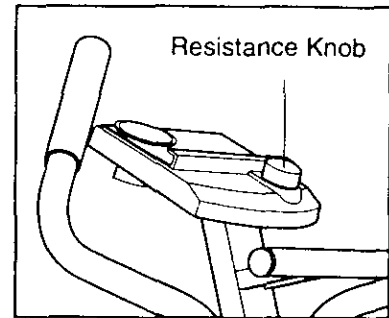

DESCRIPTION OF THE CONSOLE

The console is designed to help you get the most from your workouts. As you exercise, you can watch your progress around the LED track, while the display provides continuous exercise feedback. The six modes of the display are described below.

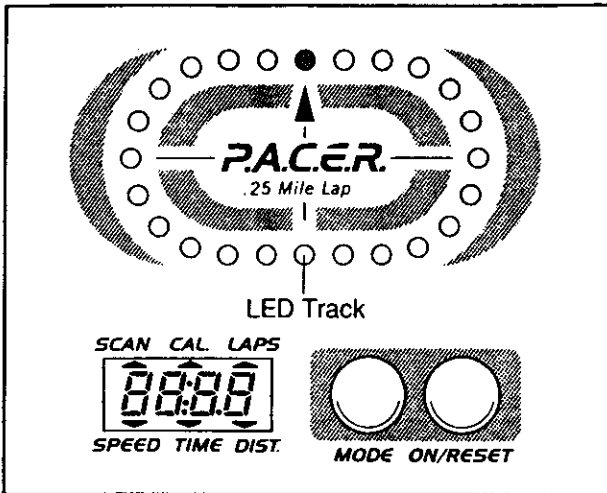

Speed—This mode displays your current exercise speed, in miles per hour.

Time—This mode displays the length of time you have exercised. Note: If you stop exercising, the time mode will pause until you resume.

Distance—This mode displays the total distance you have completed, in miles.

Laps—This mode displays the number of 1/4-mile laps you have completed around the LED track.

Calorie—This mode displays the approximate number of Calories you have burned.

Scan—This mode displays the speed, time, distance, laps, and calorie modes, for 5 seconds each, in a repeating cycle.

BATTERY INSTALLATION

Before the console can be operated, two "AA" batteries must be installed. If you have not installed batteries, see assembly step 8 on page 8.

HOW TO OPERATE THE CONSOLE

If there is a thin sheet of clear plastic on the face of the console, remove it.

1. To turn on the power, press the on/reset button or simply begin exercising. When the power is turned on, one LED indicator will light in the LED track, and the entire display will appear for two seconds. The console will then be ready for operation.
2. Select one of the five modes:

Scan mode—When the power is turned on, the scan mode will automatically be selected. One mode indicator will show that the scan mode is selected, and a flashing mode indicator will show which mode is currently displayed. Note: If a different mode is selected, you can select the scan mode again by repeatedly pressing the mode button.

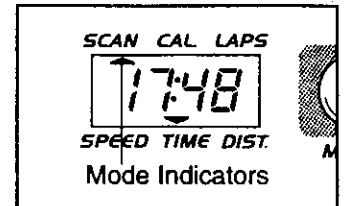

Speed, time, distance, laps, or calorie mode—To select one of these modes for continuous display, press the mode button repeatedly. The mode indicators will show which mode is selected. (Make sure that the scan mode is not selected.)

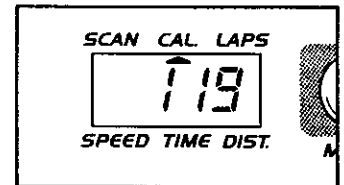

3. The LED track represents a distance of 1/4 mile. As you exercise, the indicators around the track will light one at a time until you have completed 1/4 mile. A new lap will then begin.
4. To reset the display, press the on/reset button.
5. To turn off the power, simply wait for about four minutes. **Note: The console has an "auto-off" feature. If the pedals are not moved and the console buttons are not pressed for four minutes, the power will turn off automatically in order to conserve the batteries.**

MAINTENANCE

Inspect and tighten all parts of the PROFORM® 485E regularly. Replace any worn parts immediately.

The 485E can be wiped clean with a soft cloth and mild detergent. **Do not use abrasives or solvents.** To prevent damage to the console, keep liquids away from the console. Use only a sealable water bottle in the console.

CONSOLE TROUBLE-SHOOTING

If the console does not function properly, the batteries should be replaced. To replace the batteries, refer to assembly step 8 on page 8.

STORAGE

When storing the 485E, remove the batteries from the console. Keep the 485E in a clean, dry location, away from moisture and dust.

CONDITIONING GUIDELINES

The following guidelines will help you to plan your exercise program. Remember that proper nutrition and adequate rest are essential for successful results.

WARNING: Before beginning this or any exercise program, consult your physician. This is especially important for persons over the age of 35 or persons with pre-existing health problems.

EXERCISE INTENSITY

Whether your goal is to burn fat or to strengthen your cardiovascular system, the key to achieving the desired results is to exercise with the proper intensity. The proper intensity level can be found by using your heart rate as a guide. The chart below shows recommended heart rates for fat burning, maximum fat burning, and cardiovascular (aerobic) exercise.

HEART RATE TRAINING ZONES								
MIN ♥	125	120	115	110	105	95	90	Fat Burn
BPM	145	138	130	125	118	110	103	Max Burn
MAX ♥	165	155	145	140	130	125	115	Aerobic
AGE	20	30	40	50	60	70	80	

To find the proper heart rate for you, first find your age at the bottom of the chart (ages are rounded off to the nearest ten years). Next, find the three numbers above your age. The three numbers are your "training zone." The smallest number is the recommended heart rate for fat burning; the middle number is the heart rate for maximum fat burning; the largest number is the heart rate for aerobic exercise.

Burning Fat

To burn fat effectively, you must exercise at a relatively low intensity level for a sustained period of time. During the first few minutes of exercise, your body

uses easily accessible *carbohydrate* calories for energy. Only after the first few minutes of exercise does your body begin to use stored *fat* calories for energy. If your goal is to burn fat, adjust the intensity of your exercise until your heart rate is near the smallest number in your training zone as you exercise.

For maximum fat burning, adjust the intensity of your exercise until your heart rate is near the middle number in your training zone as you exercise.

Aerobic Exercise

If your goal is to strengthen your cardiovascular system, your exercise must be "aerobic." Aerobic exercise is activity that requires large amounts of oxygen for prolonged periods of time. This increases the demand on the heart to pump blood to the muscles, and on the lungs to oxygenate the blood. For aerobic exercise, adjust the intensity of your exercise until your heart rate is near the largest number in your training zone.

HOW TO MEASURE YOUR HEART RATE

To measure your heart rate, first exercise for at least four minutes. Then, stop exercising and place two fingers on your wrist as shown.

Take a six-second heartbeat count, and multiply the result by 10 to find your heart rate.

For example, if your six-second heartbeat count is 14, your heart rate is 140 beats per minute. (A six-second count is used because your heart rate will drop rapidly when you stop exercising.)

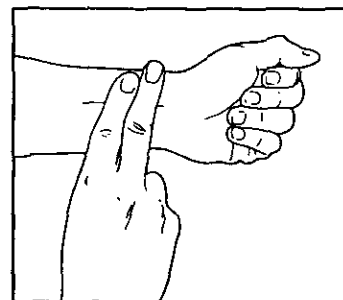

WORKOUT GUIDELINES

Each workout should include the following three important parts:

A warm-up, consisting of 5 to 10 minutes of stretching and light exercise. (See page 13.) A proper warm-up increases your body temperature, heart rate, and circulation in preparation for exercise.

Training zone exercise, consisting of 20 to 30 minutes of exercising with your heart rate in your training zone. (During the first few weeks of your exercise program, do not keep your heart rate in your training zone for longer than 20 minutes.)

A cool-down, with 5 to 10 minutes of stretching. This will increase the flexibility of your muscles and will help to prevent post-exercise problems.

EXERCISE FREQUENCY

To maintain or improve your condition, plan three workouts each week, with at least one day of rest between workouts. After a few months of regular exercise, you may plan up to five workouts each week, if desired.

Caution: Be sure to progress at your own pace and avoid overdoing it. Incorrect or excessive training may result in injury to your health.

Remember, the key to success is make exercise a regular and enjoyable part of your everyday life.

SUGGESTED STRETCHES

The correct form for several basic stretches is shown at the right. Move slowly as you stretch—never bounce.

1. Toe Touch Stretch

Stand with your knees bent slightly and slowly bend forward from your hips. Allow your back and shoulders to relax as you reach down toward your toes as far as possible. Hold for 15 counts, then relax. Repeat 3 times. Stretches: Hamstrings, back of knees, and back.

2. Hamstring Stretch

Sit with one leg extended. Bring the sole of the opposite foot forward you and rest it against the inner thigh of your extended leg. Reach toward your toes as far as possible. Hold for 15 counts, then relax. Repeat 3 times for each leg. Stretches: Hamstrings, lower back, and groin.

3. Calf/Achilles Stretch

With one leg in front of the other, reach forward and place your hands against a wall. Keep your back leg straight and your back foot flat on the floor. Bend your front leg, lean forward and move your hips toward the wall. Hold for 15 counts, then relax. Repeat 3 times for each leg. To cause further stretching of the achilles tendons, bend your back leg as well. Stretches: Calves, achilles tendons, and ankles.

4. Quadriceps Stretch

With one hand against a wall for balance, reach back and grasp one foot with your other hand. Bring your heel as close to your buttocks as possible. Hold for 15 counts, then relax. Repeat 3 times for each leg. Stretches: Quadriceps and hip muscles.

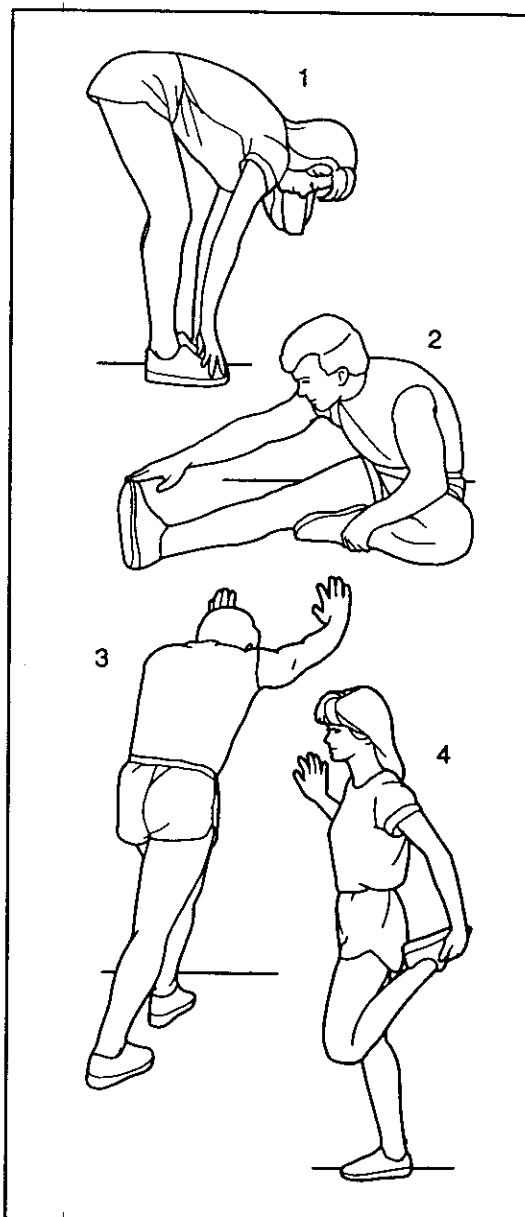

PART LIST—Model No. 831.285735

R0498A

Key No.	Qty.	Description	Key No.	Qty.	Description
1	1	Frame	37	2	Pedal Disk
2	1	Reed Switch Bracket	38	12	#8 x 3/4" Tek Screw
3	1	Upright	39	2	Handlebar Spacer
4	1	Right Side Shield	40	1	Side Shield Bracket
5	1	Left Side Shield	41	2*	Pedal Arm Spacer
6	1	Console	42	4	Pedal Arm Bushing
7	2	Foam Handlebar Grip	43	4*	3/4" Axle Cap
8	2	Handlebar	44	1	#8 x 3/4" Flat Head Screw
9	2	5/16" Lock Washer	45	1	Resistance Control Bracket
10	1	T-Handle	46	4	#8 Flat Washer
11	4	Rear Pedal Arm Bushing	47	1	Clamp Nut
12	2	Pedal Arm	48	1	Clamp Bolt
13	13	#10 x 3/4" Screw	49	2	Weld Spacer
14	1	Resistance Strap	50	1	Resistance Control Knob
15	1	Strap Buckle	51	4	#8 x 1" Screw
16	10	#8 x 3/4" Round Head Screw	52	1	Return Spring
17	2	1/4" Nylon Locknut	53	2	3/8" Washer
18	2	Adjustment Bracket	54	2	1/4" x 3/4" Screw
19	2	1/4" Eyebolt	55	2	1/4" Black Nylon Locknut
20	2	3/8" Nylon Jam Nut	56	5	Pivot Bushing
21	1	Flywheel Axle	57	2*	5/8" Axle Cap
22	2	Flywheel Bearing	58	4	Resistance Control Spacer
23	1	Flywheel	59	2	Crank Arm
24	1	Magnet	60	1	Buckle Bracket
25	1	Sensor Wire/Reed Switch	61	2	5/16" Zinc Washer
26	1	Resistance Control/Cable	62	1	#12 x 1/2" Screw
27	4	Stabilizer Endcap	63	2	T-Handle Endcap
28	1	Tension Spring	64	1	Nylon Washer
29	4	3/8" Nylon Locknut	65	1	3/4" Plastic Spacer
30	1	Belt	66	1	#8 x 2 1/2" Screw
31	2	Pedal	67	1	Right Pedal
32	1	Pulley w/Shaft	#	1	User's Manual
33	2	Crank Arm Extension	#	2	Side Shield Decal
34	2	#8 Tek Screw	#	1	Warning Decal
35	2	5/16" Zinc Bolt	#	1	Hardware Kit
36	2	Pulley Bearing			

Note: "#" indicates a non-illustrated part. "*" indicates that an extra part may be included. Specifications are subject to change without notice. See the back cover of this manual for information about ordering replacement parts.

EXPLODED DRAWING—Model No. 831.285735

R0498A

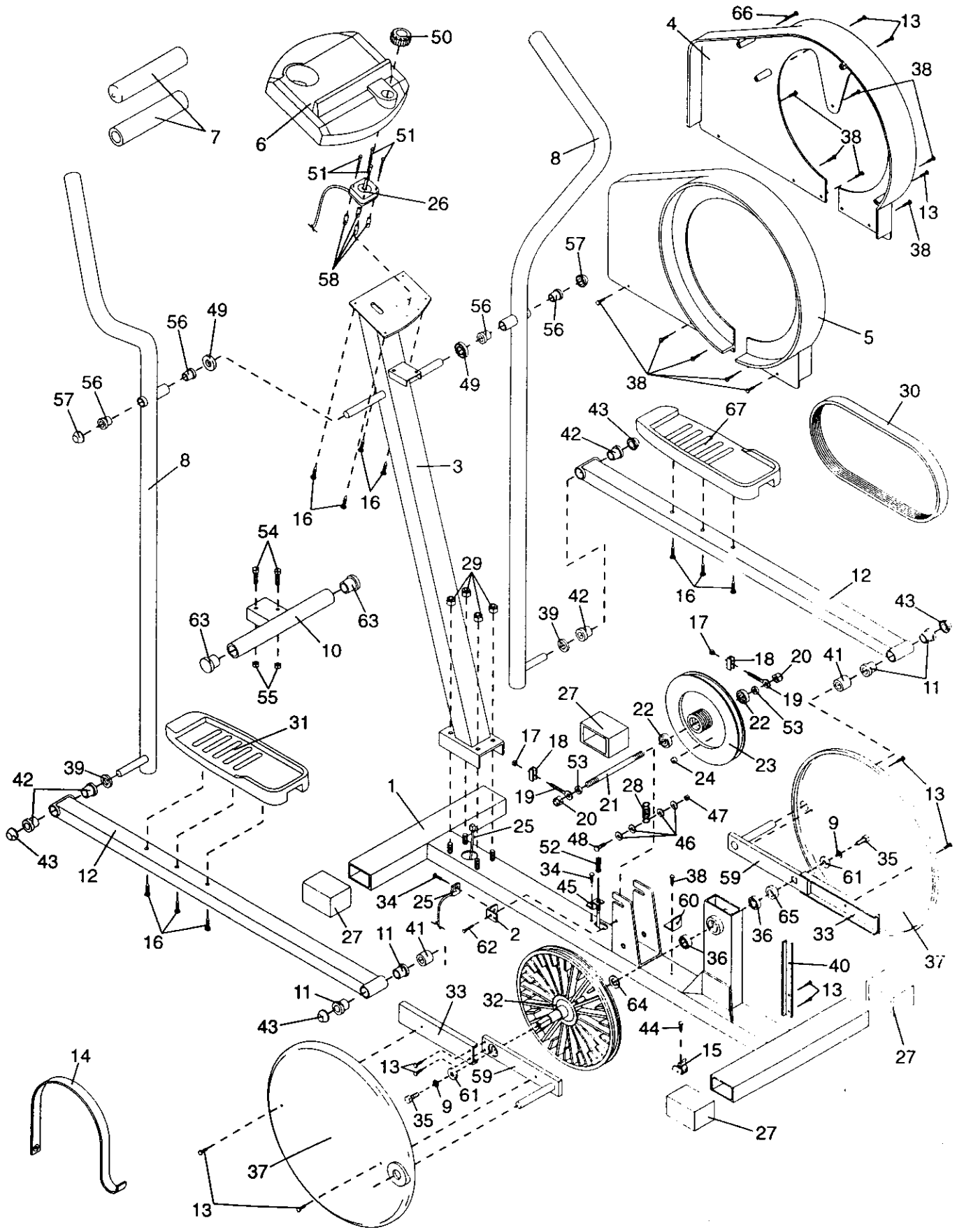

SEARS

Model No. 831.285735

QUESTIONS?

If you find that:

- you need help assembling or operating the PROFORM® 485E
- a part is missing
- or you need to schedule repair service

call our toll-free HELPLINE

1-800-736-6879

Monday-Saturday, 7 am-7 pm
Central Time (excluding holidays)

REPLACEMENT PARTS

If parts become worn and need to be replaced, call the following toll-free number

1-800-FON-PART
(1-800-366-7278)

The model number and serial number of your PROFORM® 485E are listed on a decal attached to the frame. See the front cover of this manual to find the location of the decal.

All replacement parts are available for immediate purchase or special order when you visit your nearest SEARS Service Center. To request service or to order parts by telephone, call the toll-free numbers listed at the left.

When requesting help or service, or ordering parts, please be prepared to provide the following information:

- The NAME OF THE PRODUCT (PROFORM® 485E)
- The MODEL NUMBER OF THE PRODUCT (831.285735)
- The KEY NUMBER OF THE PART (see page 14)
- The DESCRIPTION OF THE PART (see page 14).

FULL 90 DAY WARRANTY

For 90 days from the date of purchase, if failure occurs due to defect in material or workmanship in this SEARS ELLIPTICAL EXERCISER, contact the nearest SEARS Service Center throughout the United States and SEARS will repair or replace the ELLIPTICAL EXERCISER, free of charge.

This warranty does not apply when the ELLIPTICAL EXERCISER is used commercially or for rental purposes.

This warranty gives you specific legal rights, and you may also have other rights which vary from state to state.

SEARS, ROEBUCK AND CO., DEPT. 817WA, HOFFMAN ESTATES, IL 60179