

Lifestyler.



EXPANSE 2000

2.5 HP • 0-10 MPH • POWER INCLINE • EXPANDED RUNNING SURFACE

SEARS®

Model No. 831.297273

Serial No. _____

The serial number can be found in the location shown below. Write the serial number in the space above.

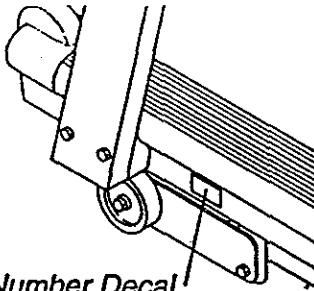

Serial Number Decal

▲ CAUTION!:

Read all safety precautions and instructions in this manual before using this equipment. Keep this manual in a safe place for future reference.

OWNER'S MANUAL

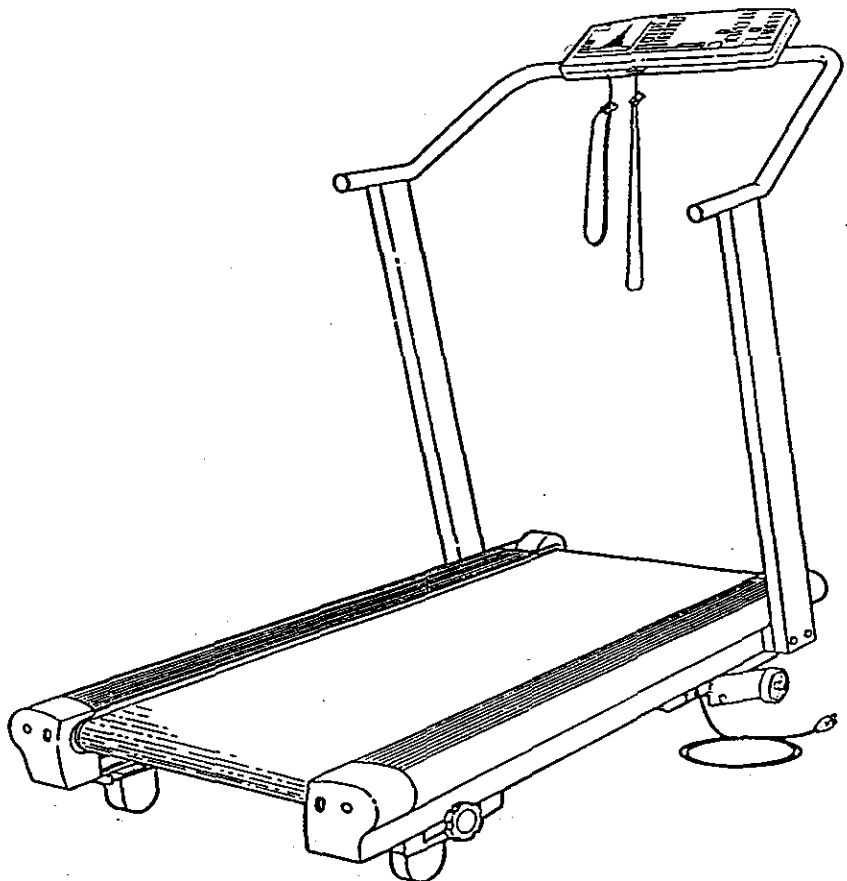

IMPORTANT SAFETY PRECAUTIONS

▲ WARNING: To reduce the risk of burns, fire, electric shock or injury to persons, read the following important safety precautions and information before operating the treadmill.

1. Position the treadmill on a level surface, with at least 8 feet of clearance behind the treadmill. Do not place the treadmill near water, outdoors or on any surface that blocks an air opening. Do not operate where aerosol products are used or where oxygen is being administered.
2. When connecting the power cord (see OPERATION AND ADJUSTMENT on page 5), plug the power cord directly into a grounded circuit capable of carrying 12 or more amps. No other appliance should be on the same circuit. Keep the power cord away from heated surfaces. If an extension cord is needed, use only a 14-gauge general-purpose cord of five feet or less in length with a three-wire conductor.
3. Never move the walking belt while the power is turned off. Do not operate the treadmill if the power cord or plug is damaged, or if the treadmill is not working properly. (See BEFORE YOU BEGIN on page 3 if the treadmill is not working properly.)
4. Wear appropriate exercise clothing when using the treadmill; do not wear loose clothing that could become caught in the treadmill. *Always wear athletic shoes; never use the treadmill with bare feet, wearing only stockings or in sandals.* Athletic support clothes are recommended for both men and women.
5. The pulse earclip is not a medical device. Various factors, including the user's movement while exercising, may affect the accuracy of heart rate readings. The earclip is intended only as an exercise aid in determining heart rate trends in general.
6. Never start the treadmill while you are standing on the walking belt. Always hold the handrail when exercising on the treadmill.
7. Never allow more than one person on the treadmill at a time. The treadmill should not be used by persons weighing more than 250 pounds.
8. Keep small children away from the treadmill at all times. Never leave the treadmill unattended while it is running. Always turn the power off when the treadmill is not in use.
9. Never drop or insert any object into any opening.
10. To reduce the possibility of overheating, do not operate the treadmill continuously for longer than 1 hour.
11. The treadmill is capable of high speeds. Adjust the speed slowly to avoid sudden jumps in speed.
12. Use the treadmill only as described in this manual.
13. Always unplug the power cord before performing the maintenance and adjustment procedures described in this manual. Never remove the safety cover unless instructed to do so by an authorized service representative. Servicing other than the procedures in this manual should be performed by an authorized service representative only.

▲ WARNING: Before beginning this or any exercise program, consult your physician. This is especially important for persons over the age of 35 or persons with pre-existing health problems. Read all instructions before using. SEARS assumes no responsibility for personal injury or property damage sustained by or through the use of this product.

TABLE OF CONTENTS

BEFORE YOU BEGIN	3
ASSEMBLY	4
OPERATION AND ADJUSTMENT	5
TROUBLE-SHOOTING AND STORAGE	10
CONDITIONING GUIDELINES	13
PART LIST	14
EXPLODED DRAWING	15
ORDERING REPLACEMENT PARTS	Back Cover
WARRANTY	Back Cover

BEFORE YOU BEGIN

Thank you for selecting the SEARS LIFESTYLER® EXPANSE 2000 treadmill. The EXPANSE 2000 treadmill blends advanced technology with innovative design to let you enjoy an excellent form of cardiovascular exercise in the convenience and privacy of your home. For your safety and benefit, read this manual carefully before using the treadmill. If you have additional questions, please call our Customer Service Department toll-free at 1-800-999-3756, Monday through Friday, 6 a.m. until 6 p.m. Mountain Time (excluding holidays). To help us assist you, please note the product model number and serial number before calling. The model number of the treadmill is 831.297273. The serial number can be found on a decal attached to the treadmill (see the front cover of this manual for the location). Before reading further, please review the drawing below and familiarize yourself with the parts that are labeled.

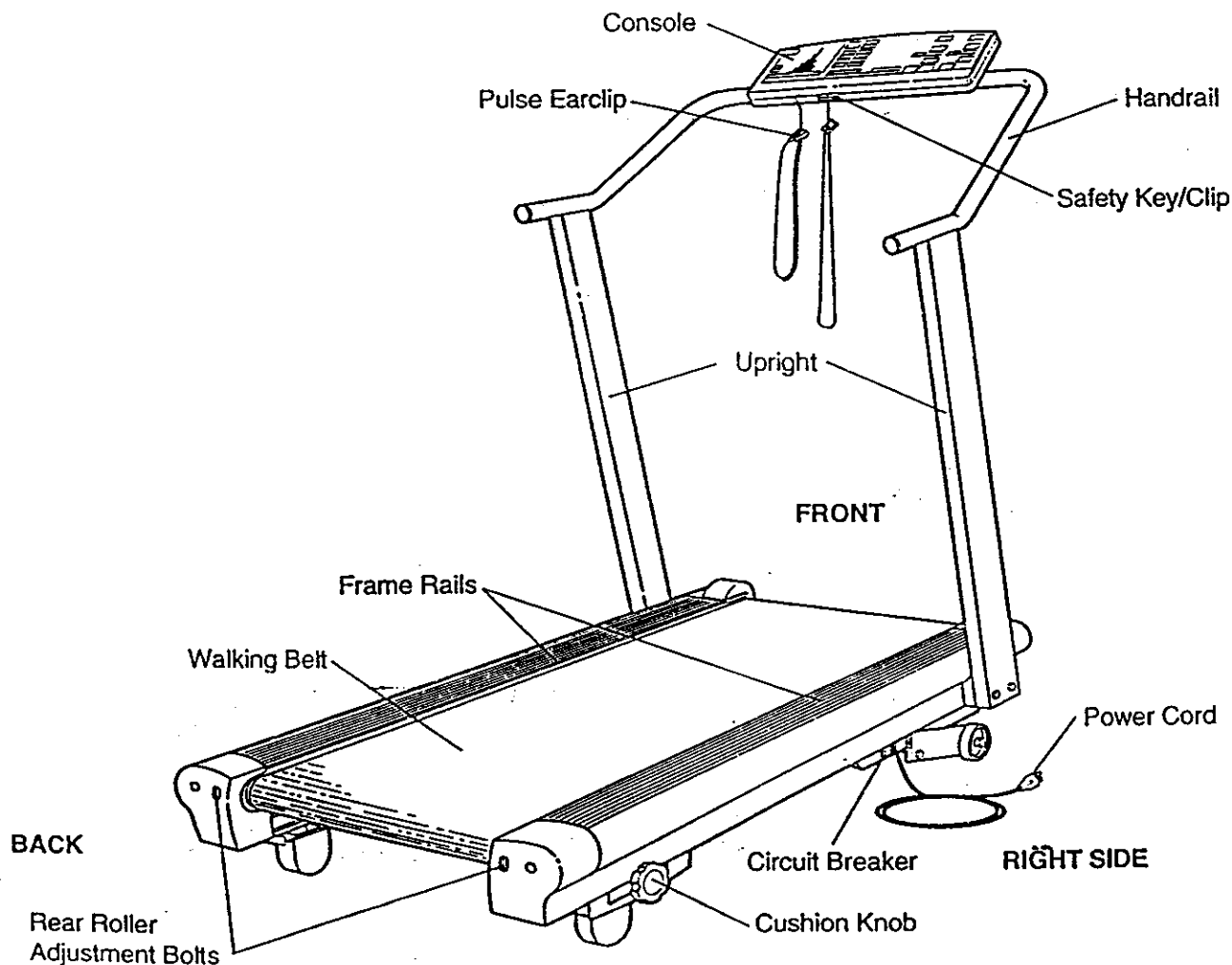

ASSEMBLY

Set the treadmill in a cleared area and remove all packing materials. Do not dispose of the packing materials until assembly is completed. **TOOLS REQUIRED FOR ASSEMBLY:** An adjustable wrench (not included). 

1. With the help of a second person, raise the right Upright (3) to a vertical position. Align the hole in the lower end of the right Upright with the hole in the side of the Right Frame Rail (47). Insert a $3/4"$ x $4 1/2"$ Bolt (2), with a Washer (1), into the right Upright. Hand tighten both Bolts (2) into the Right Frame Rail. Do not fully tighten the Bolts yet. Repeat the step with the Left Upright (not shown).

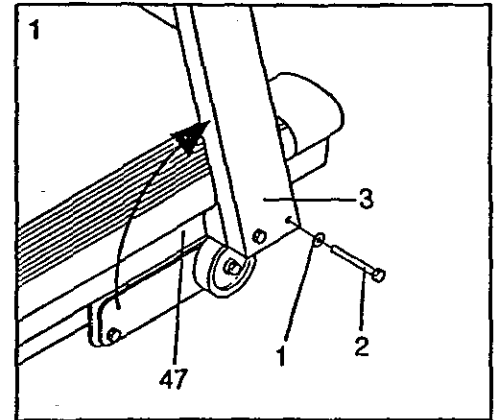

2. It is recommended that a second person hold the Handrail (5) while you complete step 2.

Connect the Handrail Wire Harness (13) to the Upright Wire Harness (30). Slide the brackets on the Handrail (5) into the right Upright (3) and the left Upright (not shown). Be careful not to damage the wires. Insert a $3/8"$ x $1 1/4"$ Bolt (7), with a Washer (1), into each Upright. It may be necessary to raise the front of the Handrail to insert the Bolts. Tighten the Bolts. Tighten the $3/4"$ x $4 1/2"$ Bolts (2) in the lower ends of the Uprights (see step 1).

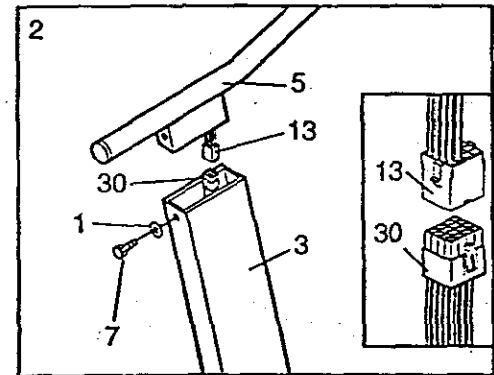

3. Slide the metal Clothes Clip onto the Pulse Earclip in the indicated location. The use of the Pulse Earclip is explained in OPERATING THE MONITOR MODES on page 9.

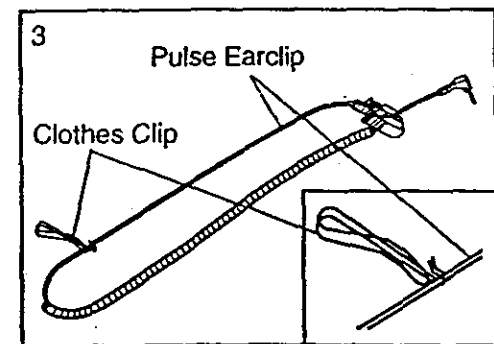

4. Remove the paper backing from the Wrench Clip (84). Press the Wrench Clip onto the Right Endcap (78) in the indicated location. Press the Allen Wrench (83) into the Wrench Clip.

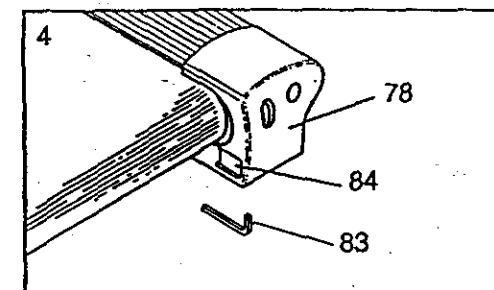

Make sure that all parts are tightened before using the treadmill. **Note:** To protect the floor, a covering should be placed under the treadmill.

OPERATION AND ADJUSTMENT

PLUGGING IN THE POWER CORD

This product must be grounded. If it should malfunction or break down, grounding provides a path of least resistance for electric current to reduce the risk of electric shock. This product is equipped with a cord having an equipment-grounding conductor and a grounding plug. Plug the power cord into an appropriate outlet that is properly installed and grounded in accordance with all local codes and ordinances.

⚠ DANGER: Improper connection of the equipment-grounding conductor can result in a risk of electric shock. Check with a qualified electrician or serviceman if you are in doubt as to whether the product is properly grounded. Do not modify the plug provided with the product—if it will not fit the outlet, have a proper outlet installed by a qualified electrician.

This product is for use on a nominal 120-volt circuit, and has a grounding plug that looks like the plug illustrated in Drawing 1. A temporary adapter that looks like the adapter illustrated in Drawing 2 may be used to connect this plug to a 2-pole receptacle as shown in Drawing 2 if a properly grounded outlet is not available. The temporary adapter should be used only until a properly grounded outlet (Drawing 1) can be installed by a qualified electrician. The green colored rigid ear, lug, or the like extending from the adapter must be connected to a permanent ground such as a properly grounded outlet box cover. Whenever the adapter is used it must be held in place by a metal screw. Some 2-pole receptacle outlet box covers are not grounded. Contact a qualified electrician to determine if the outlet box cover is grounded before using an adapter.

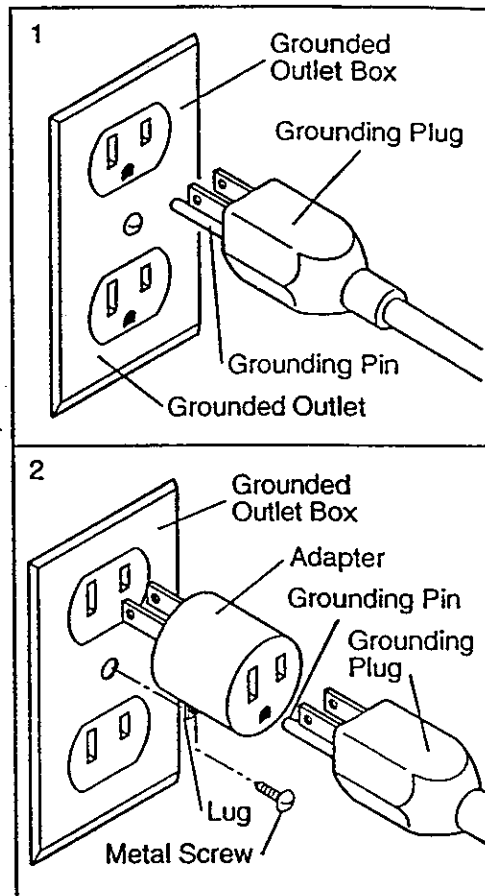

BREAKING IN THE MAINTENANCE-FREE WALKING PLATFORM

IMPORTANT: This treadmill features a maintenance-free walking platform. After completion of the following break-in procedure, the walking platform requires no further maintenance. The walking platform must be broken in completely so that the coating on the walking platform impregnates the walking belt. If this is not done, the treadmill may function erratically. Follow the steps below to break in the walking platform completely.

1. Adjust the incline of the treadmill to the highest setting. (See pages 6 and 7.)
2. Adjust the speed of the walking belt to about 3 or 4 miles per hour. (See pages 6 and 7.) Hold the handrail and begin walking on the treadmill. **Be sure to walk on all areas of the walking belt—not only on the center.** Continue for 5 to 10 minutes, or until the walking belt no longer slows as you walk.
3. To complete the break-in procedure, first stop the walking belt and unplug the power cord. Lift each side of the walking belt and apply the included lubricant generously onto the area of the walking platform shown at the right. This one-time application completes the break-in of the maintenance-free walking platform. **IMPORTANT:** The included 100% silicone lubricant is specially formulated for this one-time application. Do not apply any other silicone lubricant or spray. Such substances may damage the walking platform and cause excessive wear or premature failure of the treadmill.

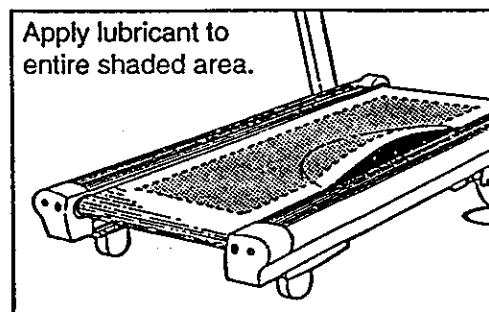

Note: The treadmill may function erratically during the break-in procedure. The walking belt may slow to a stop or surge in speed, and an error code ("EEE") may appear in the SPEED display. If this happens, remove the safety key, wait for ten seconds, and then reinsert the safety key.

DIAGRAM OF THE CONSOLE

The heart of the treadmill is the state-of-the-art programmable console. The console offers both manual and program operation, and features an array of independent LED displays to give you continuous exercise feedback. Please read these instructions carefully before operating the console. Note: If there is a sheet of protective plastic on the face of the console, peel it off before operating the console.

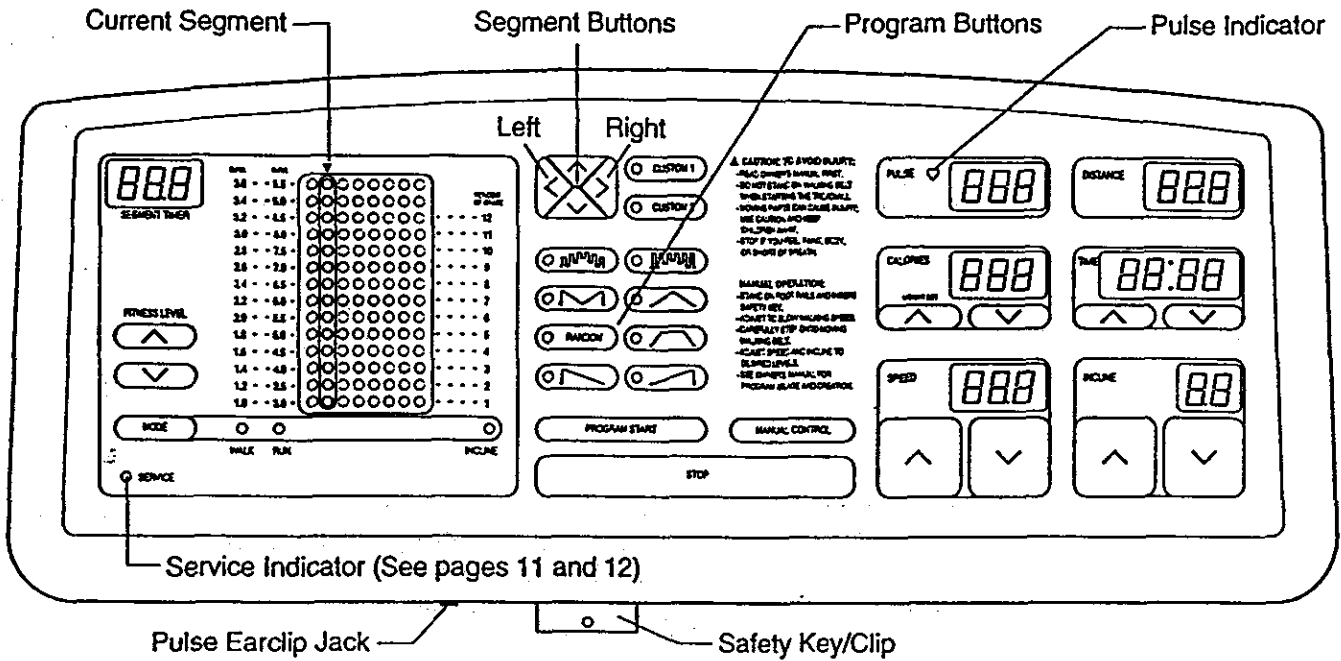

TURNING ON THE POWER

If the safety key is in the console, remove it. Plug in the power cord (see **PLUGGING IN THE POWER CORD** on page 5).

Stand on the frame rails of the treadmill. Find the clip attached by a cord to the safety key, and slide the clip onto the waistband of your clothing.

▲WARNING: Do not stand on the walking belt while turning on the power. Always wear the clip when operating the treadmill. If you fall, the safety key will be pulled from the console, instantly turning off the power.

Insert the safety key into the console. The six LED displays on the right side of the console will light. Note: If the safety key was in the console when the power cord was plugged in, a "PO" will appear in the speed display. If this occurs, remove the safety key, wait for five seconds and then reinsert it.

MANUAL OPERATION

When the power is turned on, the console will be in the manual mode and the walking belt will be stationary. The speed of the walking belt can be controlled by pressing the **SPEED** buttons. Each time the **SPEED** increase button is pressed, the speed will increase by 0.1 mile per hour, beginning at 0.5 miles per hour. Each time the **SPEED** decrease button is pressed, the speed will decrease by 0.1 mile per hour. The **SPEED** buttons can be held down to change the speed rapidly. The speed can be set at a minimum of 0.5 miles per hour, up to a maximum of 10 miles per hour.

▲WARNING: After the **SPEED** buttons are pressed, it will take a few seconds for the walking belt to reach the selected speed. Adjust the speed gradually until you are familiar with the operation of the treadmill.

Press the SPEED increase button until the walking belt begins to move at slow speed. When the walking belt begins to move, hold the handrails and step carefully onto the walking belt. Change the speed of the walking belt as desired by pressing the SPEED buttons. To stop the walking belt, hold down the SPEED decrease button. The walking belt can be stopped quickly, if desired, by pressing the STOP bar.

To vary the intensity of your exercise, the incline of the treadmill can be changed by pressing the INCLINE buttons. Each time the INCLINE increase button is pressed, the incline will increase by 0.5%. Each time the INCLINE decrease button is pressed, the incline will decrease by 0.5%. The INCLINE buttons can be held down to change the incline rapidly. The incline can be set at a minimum of 1%, up to a maximum of 12%. Note: After the INCLINE buttons are pressed, it will take a few seconds for the treadmill to reach the selected incline.

PROGRAM OPERATION

In the program mode, the console will automatically control either the speed or the incline of the treadmill. The console offers a selection of preset programs, each designed to guide you through a different type of workout. In addition, you can create custom programs, and save them in memory for future workouts.

CREATING A CUSTOM PROGRAM

Press the CUSTOM 1 or CUSTOM 2 button. The indicator on the button you press will light.

Next, press the MODE button to select the WALK, RUN or INCLINE mode. An indicator will light to show which mode you have selected. If you select the WALK mode, the speed range of the treadmill will be 1.0 mile per hour to 3.6 miles per hour during the program. If you select the RUN mode, the speed range of the treadmill will be 3.0 miles per hour to 9.5 miles per hour during the program. If you select the INCLINE mode, the incline range of the treadmill will be 1% to 12% during the program.

All programs are divided into twenty equal time periods, called segments. If the WALK or RUN mode was selected, a speed setting should now be programmed for each of the twenty segments. If the INCLINE mode was selected, an incline setting should now be programmed for each of the twenty segments. The segments are displayed in the vertical columns of indicators on the left side of the console. Seven segments are displayed at a time—the first segment is displayed in the CURRENT SEGMENT column, and the next six segments are displayed in the columns to the right of the CURRENT SEGMENT column. (See the paragraph below for an explanation of the column to the left of the CURRENT SEGMENT column.) To program a setting for the first segment, displayed in the CURRENT SEGMENT column, press the SEGMENT increase or decrease button. Each time the SEGMENT increase button is pressed, an additional indicator will light. Each time the SEGMENT decrease button is pressed, an additional indicator will darken. The M.P.H. scales or the PERCENT OF GRADE scale will show the setting you have programmed. After you have programmed a setting for the first segment, press the SEGMENT left button. All segments will move one column to the left—the first segment will disappear, the second segment will be displayed in the CURRENT SEGMENT column, and the next six segments will be displayed in the columns to the right of the CURRENT SEGMENT column. Program a setting for the second segment as described above. Repeat until you have programmed a setting for each of the twenty segments.

The lighted indicators in the column to the left of the CURRENT SEGMENT column show the range of settings you have programmed—the lower indicator shows the lowest setting, and the upper indicator shows the highest setting. If desired, the difficulty level of the program can be increased or decreased by pressing the FITNESS LEVEL buttons. If the WALK mode was selected, the speed settings of all segments will change by 0.2 miles per hour each time one of the buttons is pressed. If the RUN mode was selected, the speed settings of all segments will change by 0.5 miles per hour each time one of the buttons is pressed. If the INCLINE mode was selected, the incline settings of all segments will change by 1% each time one of the buttons is pressed. Note: The difficulty level of the program can be increased or decreased only until the upper or lower indicator reaches the top or bottom of the column.

Next, set the length of time you want the program to last by pressing the TIME buttons. The length of time will be displayed in the TIME display. Each time one of the buttons is pressed, the length of time will change by twenty seconds. The buttons can be held down to change the length of time rapidly. The program can be set to last for a minimum of 5 minutes, up to a maximum of 80 minutes. (The length of time each segment will last will be displayed in the SEGMENT TIMER display. Each segment will last for 1/20 of the length of time shown in the TIME display.)

To start the program, press the PROGRAM START button. The first segment will be displayed in the CURRENT SEGMENT column, and the treadmill will automatically adjust to the first speed or incline setting. Hold the handrails, step carefully onto the walking belt and begin exercising. The time remaining in the first segment will be shown in the SEGMENT TIMER display. When no time remains, all segments will move one column to the left—the first segment will disappear, the second segment will be displayed in the CURRENT SEGMENT column, and the treadmill will automatically adjust to the second setting. The program will continue in this manner until all twenty segments have been displayed. A tone will then sound, the walking belt will slow to a stop and the program will be completed. (If the WALK or RUN mode was selected, the incline can be controlled during the program by pressing the INCLINE buttons. If the INCLINE mode was selected, the walking belt will begin to move at 1.0 mile per hour when the program is started. The speed of the walking belt can be controlled during the program by pressing the SPEED buttons.)

While the program is running, the setting of the current segment can be changed, if desired, by pressing the SEGMENT increase and decrease buttons. If desired, the difficulty level of the entire program can be changed by pressing the FITNESS LEVEL buttons. The length of time the program will last can be changed by pressing the TIME buttons. To stop the program before the program has ended, press the STOP bar. The console will then be in the same state as if the program had been completed.

When the program is completed, a different program can be selected or the console can be switched to the manual mode by pressing the MANUAL CONTROL button. The current settings of the program will be saved in memory. The settings will be saved in memory even when the power cord is unplugged.

SELECTING A PRESET PROGRAM

Press one of the eight PROGRAM buttons. The indicator on the button you press will light.

Next, press the MODE button to select the WALK, RUN or INCLINE mode. An indicator will light to show which mode you have selected.

The speed or incline settings of the selected program will be displayed in the vertical columns of indicators on the left side of the console. Seven segments are displayed at a time. If desired, the setting of any segment can be changed. Press the SEGMENT left or right button until the segment you want to change is displayed in the CURRENT SEGMENT column. Press the SEGMENT increase or decrease buttons to change the setting of the segment.

If desired, the difficulty level of the program can be increased or decreased by pressing the FITNESS LEVEL buttons. This is done in the same manner as for a custom program.

Next, set the length of time you want the program to last by pressing the TIME buttons. This is done in the same manner as for a custom program.

To start the program, press the PROGRAM START button. The program will run in exactly the same manner as a custom program. When the program is completed, a different program can be selected or the console can be switched to the manual mode by pressing the MANUAL CONTROL button. Although the settings of a preset program can be changed, only the original program settings will be saved in memory.

OPERATING THE MONITOR MODES

PULSE: To use the pulse mode of the console, the pulse earclip must be plugged into the pulse jack. Attach the earclip to your left ear lobe and slide the metal clothes clip onto your collar. When your pulse is detected, the PULSE indicator will flash with each heartbeat. After a few seconds, your pulse will be shown in the PULSE display. If your pulse is not shown, rub your ear lobe and reposition the earclip. It may be helpful to stand still while measuring your pulse.

DISTANCE: The DISTANCE display will show the total distance you have walked or run, in miles.

CALORIE: For an accurate measurement of your Calorie expenditure, your weight should be entered into the console. To enter your weight, press the WEIGHT SET buttons. Each time one of the buttons is pressed, the weight displayed will increase or decrease by 1 pound. The buttons can be held down to enter your weight quickly.

TIME: When the console is in the manual mode, the TIME display will show the total time that you have walked or run during your workout, up to 99 minutes and 59 seconds. (If the treadmill is run for more than 99 minutes and 59 seconds, the walking belt will automatically slow to a stop. This safety feature prevents the treadmill from being left running for long periods of time.) If desired, a time goal can be set. Press the TIME buttons to set the length of time that you plan to exercise. Each time one of the buttons is pressed, the length of time displayed will change by ten seconds. The buttons can be held down to set a time goal quickly. A time goal can be set for a minimum of 10 seconds, up to a maximum of 99 minutes and 50 seconds. As you exercise, the time will be counted down. When the time goal is completed, a tone will sound and the walking belt will slow to a stop.

When the console is in the program mode, a time goal will be set and the console will count the time down. When the program is completed, a tone will sound and the walking belt will slow to a stop.

TURNING THE POWER OFF

To turn the power off, remove the safety key from the console. All displays and indicators will darken. Store the safety key in a secure location.

INFORMATION MODE

The console features an information mode to let you keep track of trip time and distance, as well as the total time and distance accumulated on the treadmill. To select the information mode, hold down the STOP bar while inserting the safety key into the console.

When the information mode is selected, the time display will show the trip time, up to 9,999 hours. The distance and pulse displays together will show the trip distance, up to 99,999 miles. The incline display will show a service code. Service code "S0" indicates that no routine service is needed. Service code "S1" or "S3" indicates that service is needed (see 6. a. and b. on page 11). While the trip time and distance are displayed, they can be reset to zero by pressing the TIME decrease button.

To view the total time and distance, press the TIME increase button. The time display will show the total time, up to 9,999 hours. The distance and pulse displays together will show the total distance, up to 99,999 miles.

To exit the information mode, remove the safety key.

CUSHION LEVEL ADJUSTMENT

For a softer cushion level as you exercise, turn the cushion knob counterclockwise. For a firmer cushion level, turn the knob clockwise. Note: The faster you run on the treadmill, the firmer the cushion level should be. If the cushion level is too soft, the treadmill will bounce excessively.

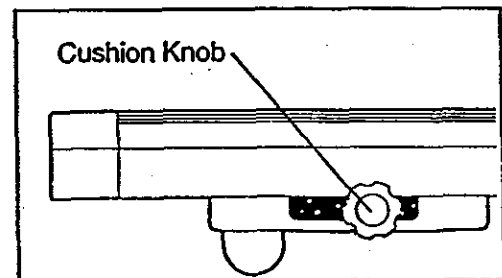

TROUBLE-SHOOTING AND STORAGE

Most treadmill problems can be solved by following the simple steps below. Find the symptom that applies to your treadmill and follow the steps listed. If further assistance is needed, please call our Customer Service Department toll-free at 1-800-999-3756, Monday through Friday, 6 a.m. until 6 p.m. Mountain Time (excluding holidays).

1. SYMPTOM: THE POWER DOES NOT TURN ON

- a. Make sure that the power cord is plugged into a properly grounded outlet. (See OPERATION AND ADJUSTMENT on page 5.) If an extension cord is needed, use only a 14-gauge general-purpose cord of five feet or less in length.
- b. After the power cord has been plugged in, make sure that the safety key is fully inserted into the console. Various indicators on the console should light. (See OPERATION AND ADJUSTMENT on page 5.)
- c. Check the circuit breaker located on the treadmill near the power cord. If the switch protrudes as shown, the circuit breaker has tripped. To reset the circuit breaker, wait for five minutes and then press the switch back in.

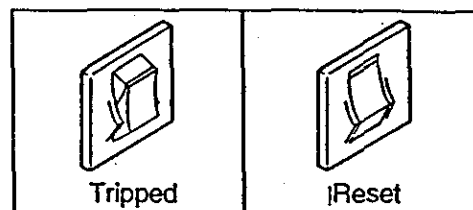

2. SYMPTOM: THE POWER TURNS OFF DURING USE

- a. Check the circuit breaker located on the treadmill near the power cord. If the circuit breaker has tripped, the switch will protrude. (See the drawing above.) To reset the circuit breaker, wait for five minutes and then press the switch back in.
- b. Make sure that the power cord is plugged in.
- c. Remove the safety key from the console. Reinsert the safety key fully into the console. Various indicators on the console should light.

3. SYMPTOM: THE PULSE EARCLIP DOES NOT FUNCTION PROPERLY

- a. Make sure that the pulse earclip is plugged fully into the jack on the console. Rub your left ear lobe and reposition the earclip. Attach the clothes clip to your collar.
- b. Stand still while measuring your pulse.
- c. The pulse earclip may need to be cleaned. Press the earclip open, and find the two clear circles inside the earclip. Wipe the two clear circles using a cotton swab saturated with denatured alcohol.

⚠ WARNING: The pulse earclip is not a medical device. Various factors, including the user's movement while exercising, may affect the accuracy of heart rate readings. The earclip is intended only as an exercise aid in determining heart rate trends in general.

4. SYMPTOM: THE WALKING BELT SLOWS WHEN WALKED ON

- a. The first time you use the treadmill, walk on the entire surface of the walking belt for 10 minutes to break in the walking platform. During this initial break-in period, it is normal for the walking belt to slow. (See also 7. a. on page 12.)
- b. If an extension cord is needed, use only a 14-gauge general-purpose cord of five feet or less in length.

- c. If the walking belt is overtightened, treadmill performance may decrease and the walking belt may be permanently damaged. Remove the safety key and **UNPLUG THE POWER CORD**. Using the allen wrench, turn both rear roller adjustment bolts counterclockwise, 1/4 of a turn. When the walking belt is properly tightened, you should be able to lift each side of the walking belt 3-4 inches off the walking platform. The center of the walking belt should just touch the walking platform. Be careful to keep the walking belt centered. Plug in the power cord, insert the safety key and run the treadmill for a few minutes. Repeat until the walking belt is properly tightened.

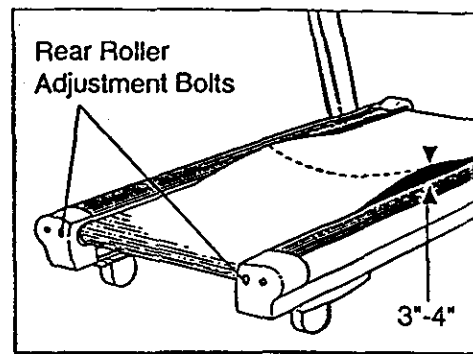

5. SYMPTOM: THE WALKING BELT IS OFF-CENTER OR SLIPS WHEN WALKED ON

- a. If the walking belt has shifted to the left, first remove the safety key and **UNPLUG THE POWER CORD**. Using the allen wrench, turn the left rear roller adjustment bolt clockwise, and the right bolt counterclockwise, 1/4 of a turn each. Be careful not to overtighten the walking belt. Plug in the power cord, insert the safety key and run the treadmill for a few minutes. Repeat until the walking belt is centered.

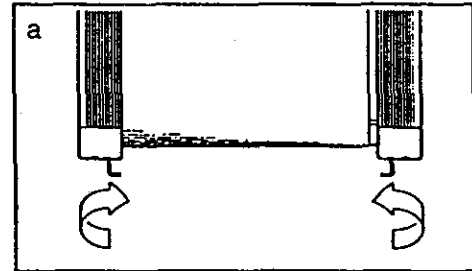

- b. If the walking belt has shifted to the right, first remove the safety key and **UNPLUG THE POWER CORD**. Using the allen wrench, turn the left rear roller adjustment bolt counterclockwise, and the right bolt clockwise, 1/4 of a turn each. Be careful not to overtighten the walking belt. Plug in the power cord, insert the safety key and run the treadmill for a few minutes. Repeat until the walking belt is centered.

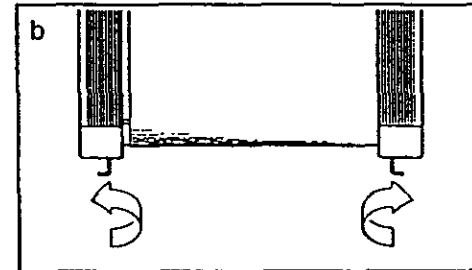

- c. If the walking belt slips when walked on, first remove the safety key and **UNPLUG THE POWER CORD**. Using the allen wrench, turn both rear roller adjustment bolts clockwise, 1/4 of a turn. When the walking belt is correctly tightened, you should be able to lift each side of the walking belt 3-4 inches off the walking platform. The center of the walking belt should just touch the walking platform. Be careful to keep the walking belt centered. Plug in the power cord, insert the safety key and run the treadmill for a few minutes. Repeat until the walking belt is properly tightened.

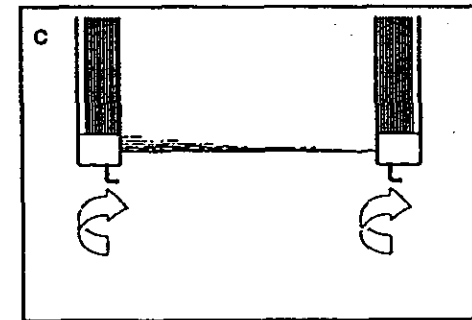

6. SYMPTOM: THE SERVICE INDICATOR ON THE CONSOLE LIGHTS

- a. The service indicator on the console is designed to alert you when routine maintenance is needed. After the treadmill has been operated for 10 miles, the service indicator will light. When the service indicator lights, the bolts attaching the console and the handrails should be tightened. In addition, the tension of the walking belt should be checked (see 4. c. above). To extinguish the service indicator, first hold down the STOP bar while inserting the safety key into the console. A service code ("S1") will appear in the INCLINE display. To reset the service code and extinguish the service indicator, hold down the STOP bar while removing the safety key.
- b. After the treadmill has been operated for 600 miles, the service indicator will again light. When the service indicator lights, the tension of the walking belt should be checked (see 4. c. above). In addition, a service technician should check the amp draw and the motor brushes. For service, see the back cover of the owner's manual. To extinguish the service indicator, first hold down the STOP bar while inserting the safety key into the console. A service code ("S3") will appear in the INCLINE display. To reset the service code and extinguish the service indicator, hold down the STOP bar while removing the safety key.

7. SYMPTOM: THE CONSOLE DOES NOT FUNCTION PROPERLY

- a. If a console malfunction occurs, an error code ("PO" or "EEE") may appear on the display. If an error code appears, remove the safety key, wait for ten seconds and then reinsert the safety key. If the error code appears again, call our Customer Service Department. Do not operate the treadmill until the problem is corrected.

STORAGE

Unplug the power cord when the treadmill is not in use. Remove the indicated bolt and washer from the lower end of each upright. Loosen the other bolts in each upright. Carefully rotate the uprights down. It is recommended that the treadmill be covered during extended periods of storage.

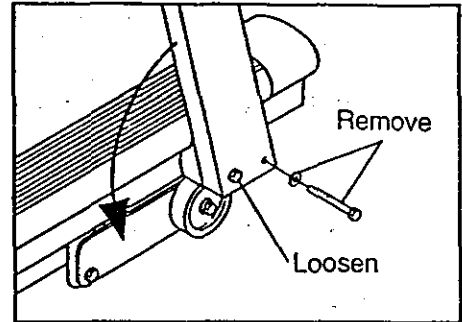

CONDITIONING GUIDELINES

The following guidelines will help you to plan your exercise program. Remember that proper nutrition and adequate rest are essential for successful results.

▲ WARNING: Before beginning this or any exercise program, consult your physician. This is especially important for individuals over the age of 35 or individuals with pre-existing health problems.

EXERCISE INTENSITY

To maximize the benefits of exercising, it is important to exercise with the proper intensity. The proper intensity level can be found by using your heart rate as a guide. For effective aerobic exercise, your heart rate should be maintained at a level between 70% and 85% of your maximum heart rate as you exercise. This is known as your training zone. You can find your training zone in the table below.

AGE	UNCONDITIONED TRAINING ZONE (BEATS/MIN)	CONDITIONED TRAINING ZONE (BEATS/MIN)	AGE	UNCONDITIONED TRAINING ZONE (BEATS/MIN)	CONDITIONED TRAINING ZONE (BEATS/MIN)
20	138-167	133-162	55	127-155	122-149
25	136-166	132-160	60	126-153	121-147
30	135-164	130-158	65	125-151	119-145
35	134-162	129-156	70	123-150	118-144
40	132-161	127-155	75	122-147	117-142
45	131-159	125-153	80	120-146	115-140
50	129-156	124-150	85	118-144	114-139

During the first few months of your exercise program, keep your heart rate near the low end of your training zone as you exercise. After a few months of regular exercise, your heart rate can be increased gradually until it is near the middle of your training zone as you exercise. You can measure your heart rate using the pulse mode of the console. Exercise for at least four minutes, and then measure your heart rate immediately. If your heart rate is too high, decrease the intensity of your exercise. If your heart rate is too low, increase the intensity of your exercise.

▲ WARNING: The pulse earclip is not a medical device. Various factors, including your movement during exercise, may affect the accuracy of heart rate readings. The earclip is intended only as an exercise aid in determining heart rate trends in general.

WORKOUT GUIDELINES

Each workout should consist of three basic parts: a warm-up, 20 to 30 minutes of training zone exercise, and a cool-down. Warming up prepares the body for exercise by increasing circulation, delivering more oxygen to the muscles and raising the body temperature. Begin each workout with 5 to 10 minutes of stretching and light exercise to warm up. Then, increase the intensity of your exercise to raise your heart rate to your training zone for 20 to 30 minutes. Breathe regularly and deeply as you exercise—never hold your breath. Finish each workout with 5 to 10 minutes of stretching to cool down. This will increase the flexibility of your muscles as well as help to decrease soreness and other post-exercise problems.

To maintain or improve your condition, complete three workouts each week, with at least one day of rest between workouts. After a few months of regular exercise, you may complete up to five workouts each week, if desired. The key to success is CONSISTENCY.

PART LIST—Model No. 831.297273

R894B

Key No.	Part No.	Qty.	Description	Key No.	Part No.	Qty.	Description
1	014086	6	Upright Washer	53	109370	1	Optic Disk
2	013485	4	3/8" x 4 1/2" Upright Bolt	54	012108	6	Nut
3	114375	2	Upright	55	115523	1	Incline Motor
4	114005	2	Handrail Endcap	56	117827	1	Left Frame Rail
5	114371	1	Handrail	57	013369	2	Incline Bolt
6	105477	16	Flange Nut	58	013211	14	Motor Frame Bolt
7	114489	2	3/8" x 1 1/4" Handrail Bolt	59	115475	1	Incline Leg
8	113005	1	Rod Endcap	60	113605	2	Rear Roller Insert
9	106939	1	Motor Belt	61	052014	2	Wheel
10	112589	1	Pulse Earclip/Clothes Clip	62	013399	2	Wheel Bolt
11	115065	1	Console	63	031229	1	Power Cord
12	108404	4	Console Screw	64	013547	2	Incline Leg Bolt
13	120999	1	Handrail Wire Harness	65	019084	1	Grommet
14	113003	2	Cushion Spring Insert	66	113980	1	Motor Frame
15	114265	1	Safety Key/Clip	67	114345	2	Cushion Cover
16	103053	2	Motor Bolt	68	111869	6	Cage Nut
17	113278	1	Pulley/Flywheel/Fan	69	115468	2	Belt Guide
18	012082	5	Tension Nut/Spring Foot Nut	70	115755	1	Front Roller/Pulley
19	014041	2	Tension Washer	71	108080	16	Small Screw
20	104514	1	Tension Spring	72	117829	1	Walking Platform
21	103855	1	J-Bolt	73	121026	1	Front Safety Cover
22	105444	1	Front Roller Adj. Bolt	74	114004	1	Rear Safety Cover
23	013303	2	Motor Swivel Bolt	75	117383	1	Cushion Spring Crossbar
24	014066	2	Lock Washer	76	013162	21	Screw
25	109365	1	Choke	77	110926	4	Cushion Spring Bolt
26	117400	1	Right Front Endcap	78	120974	1	Right Rear Endcap
27	113264	1	Left Upright Spacer	79	013300	3	Endcap Screw
28	120975	1	Front Left Endcap	80	113603	1	Right Front Roller Insert
29	110447	1	Controller	81	115046	2	Cushion Spring Foot
30	114366	1	Upright Wire Harness	82	115059	1	Rear Roller
31	120740	1	Motor	83	045010	1	Allen Wrench
32	116340	1	Motor Swivel Shaft	84	016028	1	Wrench Clip
33	106053	2	Cushion Spring Spacer	85	119071	1	Speed Optic Switch Bracket
34	115053	1	Walking Belt	86	119070	1	Speed Optic Disk
35	015071	4	Plastic Stand-Off	87	111894	1	Cushion Knob
36	108062	1	Power Board	88	116590	1	Left Front Roller Insert
37	114037	1	Mounting Plate	89	115293	1	Choke Plate
38	012155	2	Push Nut	90	116093	1	Front Cover Plate
39	013206	2	Rear Roller Adjustment Bolt	91	117925	1	Rear Cover Plate
40	014127	3	Adjustment Washer	92	014157	1	Star Washer
41	120973	1	Left Rear Endcap	93	117395	1	Optic Switch Bracket Nut
42	113265	1	Right Handrail Spacer	94	103646	1	14" Optic Switch Wire Harness
43	109382	1	Circuit Breaker	95	109250	1	12" Cable Loom
44	114356	1	Adjustment Rod	96	016029	2	4" Cable Tie
45	115404	2	Reinforcement Plate	#	102634	1	8" Green Ground Wire, F/R
46	102633	1	20" Optic Switch Wire Harness	#	101951	1	8" Black Wire, 2 Female
47	117828	1	Right Frame Rail	#	101898	1	14" Black Wire, 2 Female
48	116586	12	Deck Screw	#	107771	1	8" White Wire, Male/Female
49	012152	2	Switch Nut	#	101897	1	14" White Wire, 2 Female
50	116511	3	Oblong Washer	#	105989	1	Controller-Power Board Wire
51	102955	2	Optic Switch	#	114261	1	8" Green Ground Wire, 2 Ri
52	102959	2	Switch Bolt	#	121021	1	Owner's Manual

Note: "#" indicates a non-illustrated part. Specifications are subject to change without notice. See the back cover for information about ordering replacement parts.

EXPLODED DRAWING—Model No. 831.297273

R894B

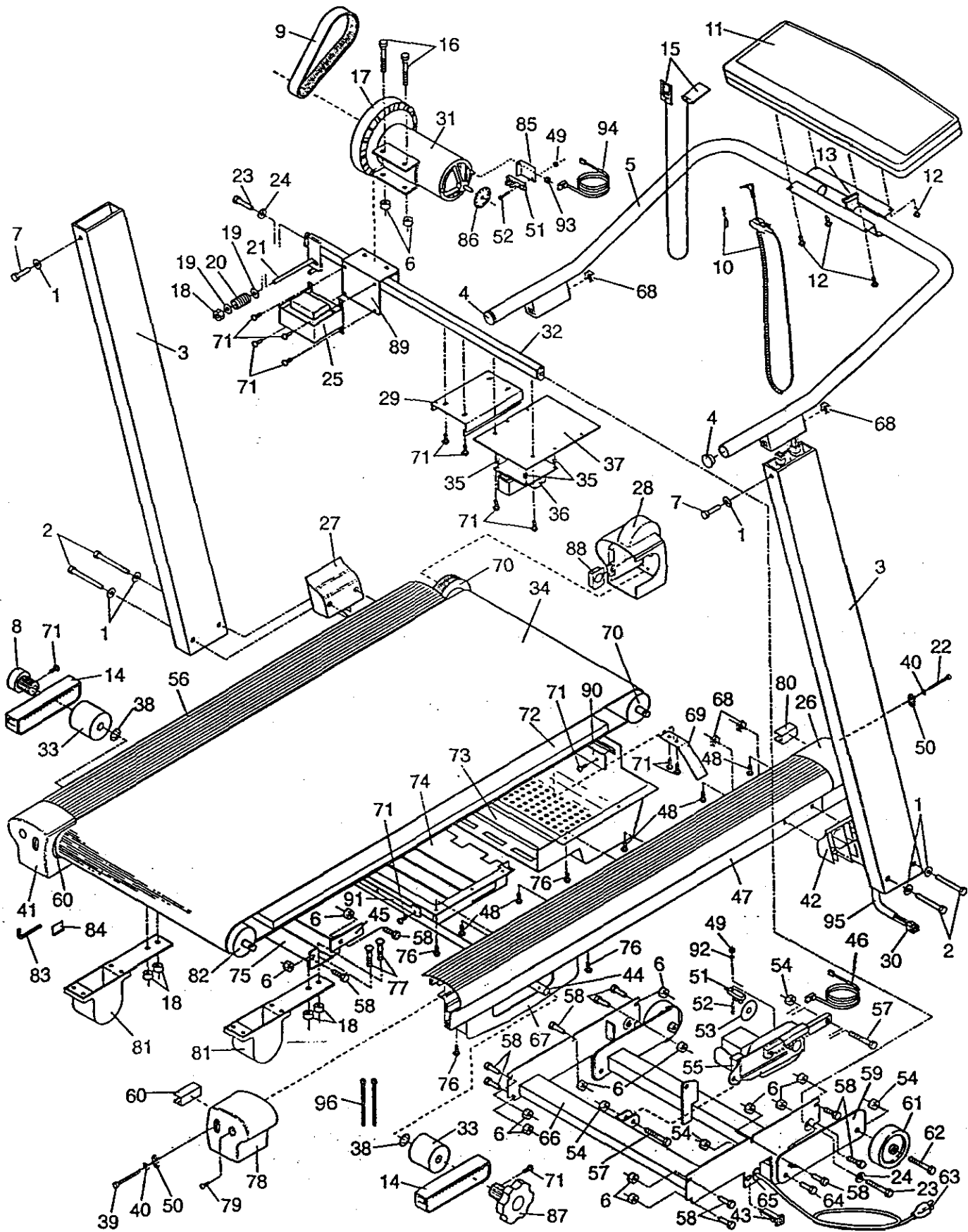

ORDERING REPLACEMENT PARTS

Each TREADMILL has its own MODEL NUMBER. Always mention this MODEL NUMBER when requesting service or repair parts for your TREADMILL.

All parts listed herein can be ordered through SEARS, ROEBUCK AND CO. SERVICE CENTERS and most SEARS RETAIL STORES. If parts you need are not stocked locally, your order will be transmitted to a SEARS PARTS DISTRIBUTION CENTER for handling.

WHEN ORDERING REPAIR PARTS, ALWAYS GIVE THE FOLLOWING INFORMATION:

1. The MODEL NUMBER of the product (831.297273).
2. The NAME of the product (SEARS LIFESTYLER® EXPANSE 2000 treadmill).
3. The PART NUMBER of the part(s) from page 14 of this owner's manual.
4. The DESCRIPTION of the part(s) from page 14 of this owner's manual.

Your SEARS TREADMILL has added value when you consider that SEARS has service units nationwide, staffed with SEARS trained technicians specifically trained on SEARS products, having the parts, tools and equipment to ensure that we meet our pledge to you: "We service what we sell."

Should you ever need repair service or parts, call toll free:

For repair service: 1-800-4-REPAIR (1-800-473-7247)

For repair parts: 1-800-FON-PART (1-800-366-7278)

FULL 90 DAY WARRANTY

For 90 days from the date of purchase, when proper assembly and maintenance procedures detailed in the Owner's Manual are followed, SEARS will, free of charge, repair or replace and install a replacement part for any defective part, when this treadmill is used in a normal manner.

This warranty does not apply when this treadmill is used for commercial or rental purposes.

SERVICE IS AVAILABLE SIMPLY BY CONTACTING YOUR NEAREST SEARS SERVICE CENTER/DEPARTMENT IN THE UNITED STATES.

This warranty gives you specific legal rights, and you may also have other rights which vary from state to state.

**SEARS, ROEBUCK AND CO., DEPT. 817WA,
3333 BEVERLY ROAD, HOFFMAN ESTATES, IL 60179**