

IMPORTANT MANUAL

Do Not Throw Away

Poulan PRO

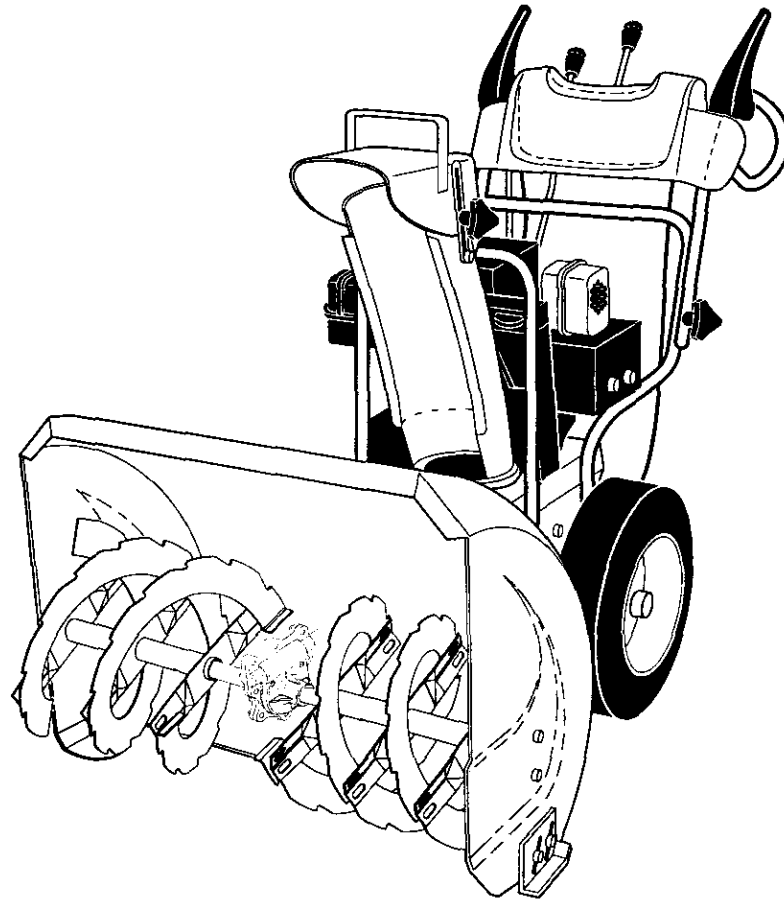

OWNER'S MANUAL

MODEL NUMBER:
PP524A
SNOW THROWER

⚠ WARNING:
Read the Owner's Manual and follow all Warnings and Safety Instructions. Failure to do so can result in serious injury.

Always Wear Eye Protection During Operation

187877 07.31.03 BY
Printed in U.S.A.



SAFETY RULES





Safe Operation Practices for Snow Throwers

IMPORTANT: This machine is capable of amputating hands and feet and throwing objects. Failure to observe the following safety instructions could result in serious injury or death.

 **Look for this symbol to point out important safety precautions. It means CAUTION!!! BECOME ALERT!!! YOUR SAFETY IS INVOLVED.**

 **WARNING: Always disconnect spark plug wire and place it where it cannot contact plug in order to prevent accidental starting when setting up, transporting, adjusting or making repairs.**

 **WARNING: This snow thrower is for use on sidewalks, driveways and other ground level surfaces. Caution should be exercised while using on sloping surfaces. Do not use snow thrower on surfaces above ground level such as roofs of residences, garages, porches or other such structures or buildings.**

 **WARNING: Snow throwers have exposed rotating parts, which can cause severe injury from contact, or from material thrown from the discharge chute. Keep the area of operation clear of all persons, small children and pets at all times including startup.**

 **CAUTION: Muffler and other engine parts become extremely hot during operation and remain hot after engine has stopped. To avoid severe burns on contact, stay away from these areas.**

 **WARNING: Engine exhaust, some of its constituents, and certain vehicle components contain or emit chemicals known to the State of California to cause cancer and birth defects or other reproductive harm.**

TRAINING

- Read the operating and service instruction manual carefully. Be thoroughly familiar with the controls and the proper use of the equipment. Know how to stop the unit and disengage the controls quickly.
- Never allow children to operate the equipment. Never allow adults to operate the equipment without proper instruction.
- Keep the area of operation clear of all persons, particularly small children and pets.
- Exercise caution to avoid slipping or falling especially when operating in reverse.

PREPARATION

- Remove foreign objects. Thoroughly inspect the area where the equipment is to be used and remove all doormats, sleds, boards, wires, rocks & landscaping.
- Disengage all clutches before starting engine (motor).

- Do not operate the equipment without wearing adequate winter outer garments. Avoid loose, dangling clothing, such as scarves, which can get caught in rotating parts. Wear footwear that will improve footing on slippery surfaces.
- Handle fuel with care; it is highly flammable.
 - Never smoke while refueling.
 - Use an approved fuel container.
 - Never remove fuel tank cap or add fuel to a running engine (motor) or hot engine (motor).
 - Fill fuel tank outdoors with extreme care. Never fill fuel tank indoors.
 - Replace fuel cap securely and wipe up spilled fuel.
 - Never store fuel or snow thrower with fuel in the tank inside of a building where fumes may reach an open flame or spark.
 - Check fuel supply before each use, allowing space for expansion as the heat of the engine (motor) and/or sun cause fuel to expand.

STATIC ELECTRICITY HAZARD -

- Never fill containers inside a vehicle or on a truck or trailer bed with a plastic liner. Always place containers on the ground, away from your vehicle before filling.
- When practical, remove gas-powered equipment from the truck or trailer and refuel it on the ground. If this is not possible, then refuel such equipment on a trailer with a portable container, rather than from a gasoline dispenser nozzle.
- Keep the nozzle in contact with the rim of the fuel tank opening at all times, until refueling is complete. Do not use a nozzle lock-open device.
- If fuel is spilled on clothing, change clothing immediately.
- For all units with electric starting motors use electric starting extension cords certified CSA/UL. Use only with a receptacle that has been installed in accordance with local inspection authorities.
- If snow thrower must be operated over gravel surface, use extra caution and be sure skid plates are adjusted to lowest (highest scraper clearance) position.
- Never attempt to make any adjustments while the engine (motor) is running (except when specifically recommended by manufacturer).
- Let engine (motor) and snow thrower adjust to outdoor temperatures before starting to clear snow.
- Always wear safety glasses or eye shields during operation or while performing an adjustment or repair to protect eyes from foreign objects that may be thrown from the snow thrower.

OPERATION

- Do not operate this machine if you are under the influence of alcohol or taking drugs or other medication which can cause drowsiness or affect your ability to operate this machine.
- Do not use this machine if you are mentally or physically unable to operate this machine safely.

- Do not put hands or feet near or under rotating parts. Keep clear of the discharge opening and front auger area at all times.
- Exercise extreme caution when operating on or crossing gravel drives, walks or roads. Stay alert for hidden hazards or traffic.
- After striking a foreign object, stop the engine (motor), remove wire from the spark plug, thoroughly inspect snow thrower for any damage, and repair the damage before restarting and operating the snow thrower.
- If the unit should start to vibrate abnormally, stop the engine (motor) and check immediately for the cause. Vibration is generally a warning of trouble.
- Stop the engine (motor) whenever you leave the operating position, before unclogging the auger/impeller housing or discharge chute and when making any repairs, adjustments, or inspections.
- When cleaning, repairing, or inspecting, make certain all controls are disengaged and the auger/impeller and all moving parts have stopped. Disconnect the spark plug wire and keep the wire away from the spark plug to prevent accidental starting.
- Take all possible precautions when leaving the snow thrower unattended. Disengage the auger/impeller, stop engine (motor), and remove key.
- Do not run the engine (motor) indoors, except when starting the engine (motor) and for transporting the snow thrower in or out of the building. Open the outside doors.



WARNING: Exhaust fumes are dangerous (containing CARBON MONOXIDE, an ODORLESS and DEADLY GAS).

- Do not clear snow across the face of slopes. Exercise extreme caution when changing direction on slopes. Do not attempt to clear steep slopes.
- Never operate the snow thrower without proper guards, plates or other safety protective devices in place.
- Never operate the snow thrower near glass enclosures, automobiles, window wells, drop-offs, and the like without proper adjustment of the snow discharge angle. Keep children and pets away.

CONGRATULATIONS on your purchase of a new snow thrower. It has been designed, engineered and manufactured to give best possible dependability and performance.

Should you experience any problem you cannot easily remedy, please contact your nearest authorized service center/department. We have competent, well-trained technicians and the proper tools to service or repair this unit.

Please read and retain this manual. The instructions will enable you to assemble and maintain your snow thrower properly. Always observe the "SAFETY RULES".

SERIAL NUMBER: _____

DATE OF PURCHASE: _____

THE MODEL AND SERIAL NUMBERS WILL BE FOUND ON A DECAL ATTACHED TO THE REAR OF THE SNOW THROWER HOUSING.

YOU SHOULD RECORD BOTH SERIAL NUMBER AND DATE OF PURCHASE AND KEEP IN A SAFE PLACE FOR FUTURE REFERENCE.

- Do not overload the machine capacity by attempting to clear snow at too fast a rate.
- Never operate the machine at high transport speeds on slippery surfaces. Look behind and use care when backing up.
- Never direct discharge at bystanders or allow anyone in front of the unit.
- Disengage power to the auger/impeller when snow thrower is transported or not in use.
- Use only attachments and accessories approved by the manufacturer of the snow thrower (such as wheel weights, counterweights, cabs, tire chains, electric start kits, etc.).
- Never operate the snow thrower without good visibility or light. Always be sure of your footing and keep a firm hold on the handles. Walk; never run.
- Do not overreach. Keep proper footing and balance at all times.
- This snow thrower is for use on sidewalks, driveways and other ground level surfaces.
- Do not use the snow thrower on surfaces above ground level such as roofs of residences, garages, porches or other such structures or buildings.

MAINTENANCE AND STORAGE

- Check shear bolts and other bolts at frequent intervals for proper tightness to be sure the equipment is in safe working condition.
- Never store the snow thrower with fuel in the tank inside a building where ignition sources are present such as hot water and space heaters, clothes dryers, and the like. Allow the engine (motor) to cool before storing in any enclosure.
- Always refer to operator's guide instructions for important details if the snow thrower is to be stored for an extended period.
- Maintain or replace safety and instruction labels, as necessary.
- Run the snow thrower, with auger engaged, a few minutes after throwing snow to clear the machine and prevent freeze-up of the auger/impeller.

PRODUCT SPECIFICATIONS

| | |
|-----------------------------|-----------------------------------------------------------------------------------|
| Gasoline Capacity and Type: | 2.0 Quarts Unleaded Regular only |
| Oil Type (API-SF-SJ): | SAE 30 (above 40°F) SAE 5W-30 or 10W-30 (0° to +40°F) SAE 0W-30 (below 0°F) |
| Oil Capacity: | 21 Ounces |
| Spark Plug: | Champion RN4C (Gap: .030") |

CUSTOMER RESPONSIBILITIES

- Read and observe the safety rules.
- Follow a regular schedule in maintaining, caring for and using your snow thrower.
- Follow the instructions under "Maintenance" and "Storage" sections of this owner's manual.

SAFETY RULES 2-3
 PRODUCT SPECIFICATIONS 3
 CUSTOMER RESPONSIBILITIES 3
 WARRANTY 32
 ASSEMBLY / PRE-OPERATION 5-7
 OPERATION 8-13

MAINTENANCE 14-15
 MAINTENANCE SCHEDULE 14
 SERVICE AND ADJUSTMENTS 16-18
 STORAGE 18
 TROUBLESHOOTING 19
 REPAIR PARTS 20-31

PARTS PACKED SEPARATELY IN CARTON

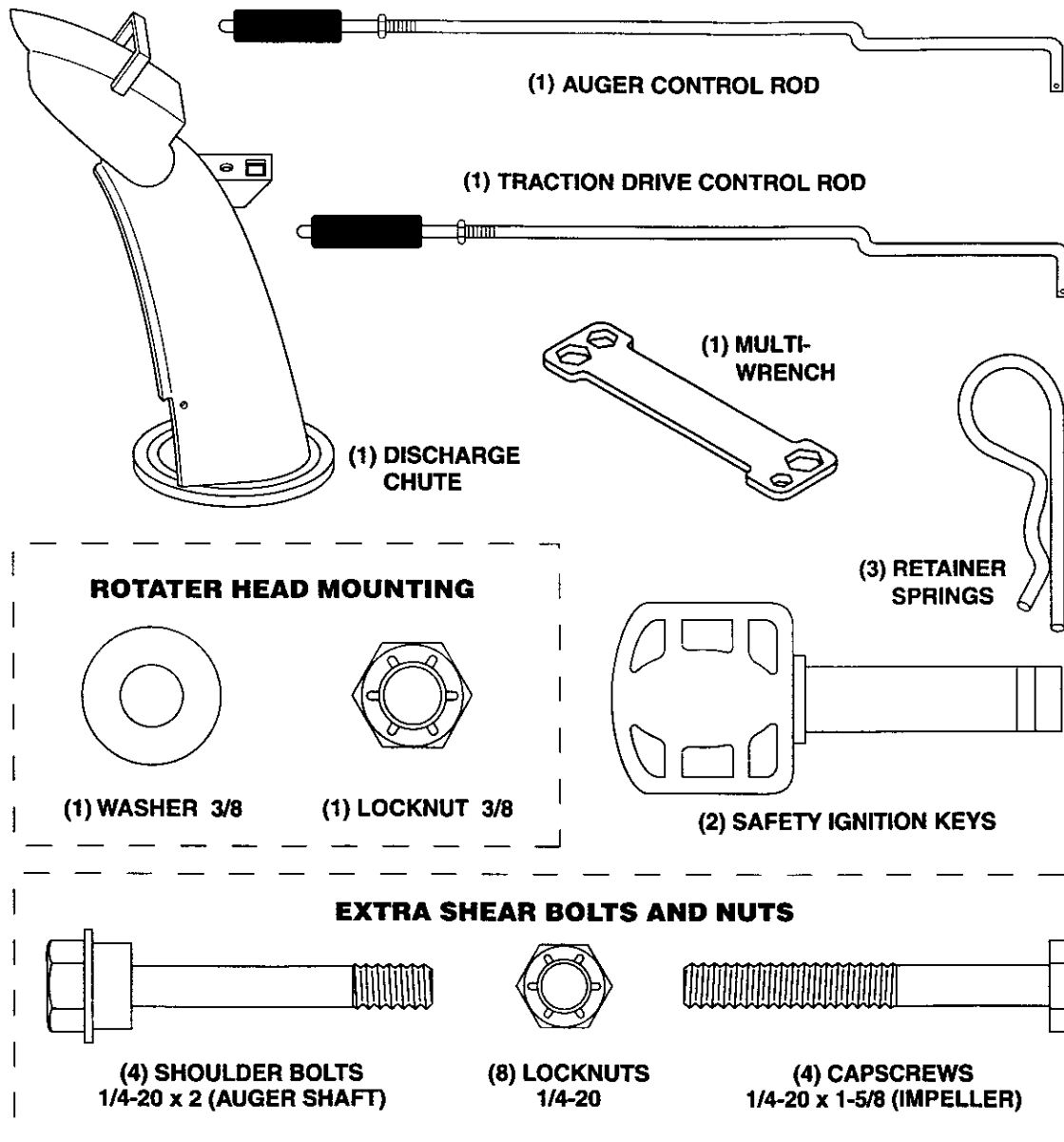

ASSEMBLY / PRE-OPERATION

Read these instructions and this manual in its entirety before you attempt to assemble or operate your new snow thrower.

Your new snow thrower has been assembled at the factory with the exception of those parts left unassembled for shipping purposes. All parts such as nuts, washers, bolts, etc., necessary to complete the assembly have been placed in the parts bag. To ensure safe and proper operation of your snow thrower, all parts and hardware you assemble must be tightened securely. Use the correct tools as necessary to ensure proper tightness.

REMOVE SNOW THROWER FROM CARTON

1. Remove all accessible loose parts and parts boxes from carton.
2. Cut down all four corners of carton and lay panels flat.
3. Remove all packing materials except plastic tie holding speed control rod to lower handle.
4. Remove snow thrower from carton and check carton thoroughly for additional loose parts.

HOW TO SET UP YOUR SNOW THROWER

TOOL BOX (See Fig. 8)

A toolbox is provided on your snow thrower. The toolbox is located on top of the belt cover. Store the extra shear bolts, nuts and multi-wrench provided in parts bag in the toolbox.

NOTE: The multi-wrench may be used for assembly of the chute rotator head to snow thrower and making adjustments to the skid plates.

UNFOLD UPPER HANDLE

1. Raise upper handle to the operating position and tighten handle knobs securely.

INSTALL SPEED CONTROL ROD (See Figs. 1 and 2)

1. Remove plastic tie securing rod to lower handle.
2. Insert rod into speed control bracket and secure with retainer spring.

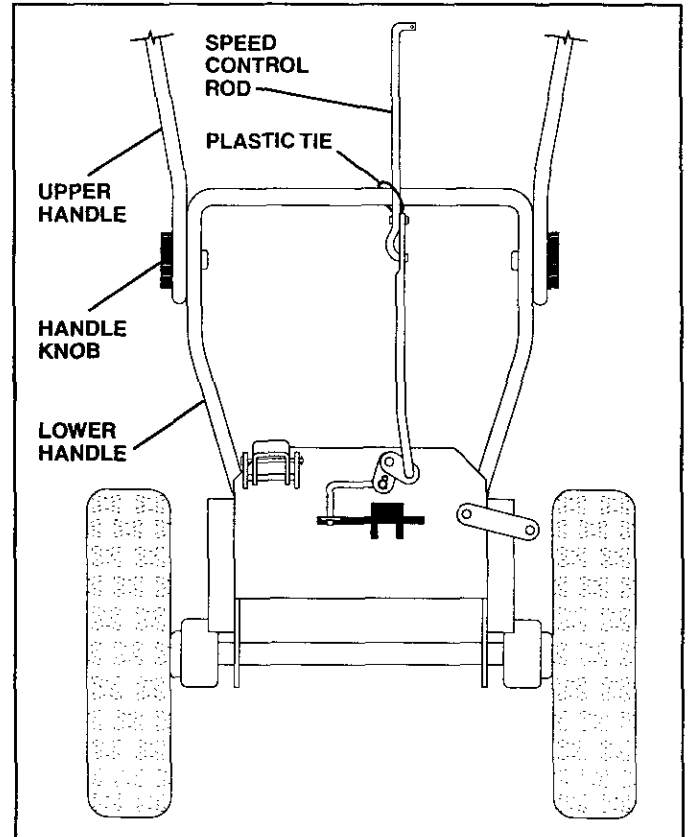

FIG. 1

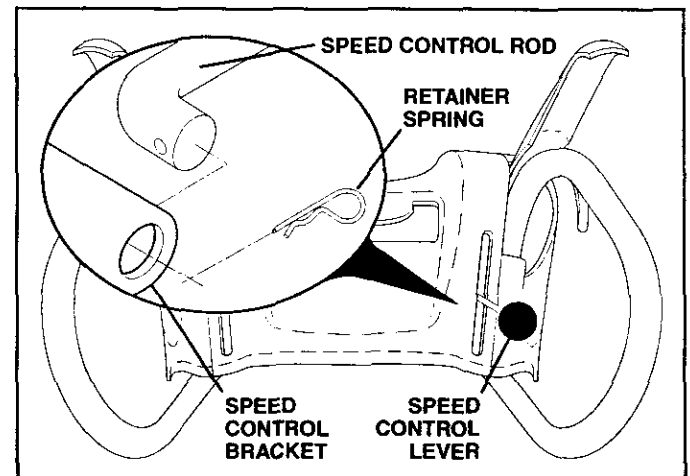

FIG. 2

ASSEMBLY / PRE-OPERATION

INSTALL TRACTION DRIVE CONTROL ROD (See Figs. 3 and 4)

The traction drive control rod has the long loop on the end of the spring as shown.

1. Slide rubber sleeve up rod and hook end of spring into pivot bracket with loop opening down as shown.
2. With top end of rod positioned under left side of control panel, push rod down and insert top end of rod into hole in drive control bracket. Secure with retainer spring.

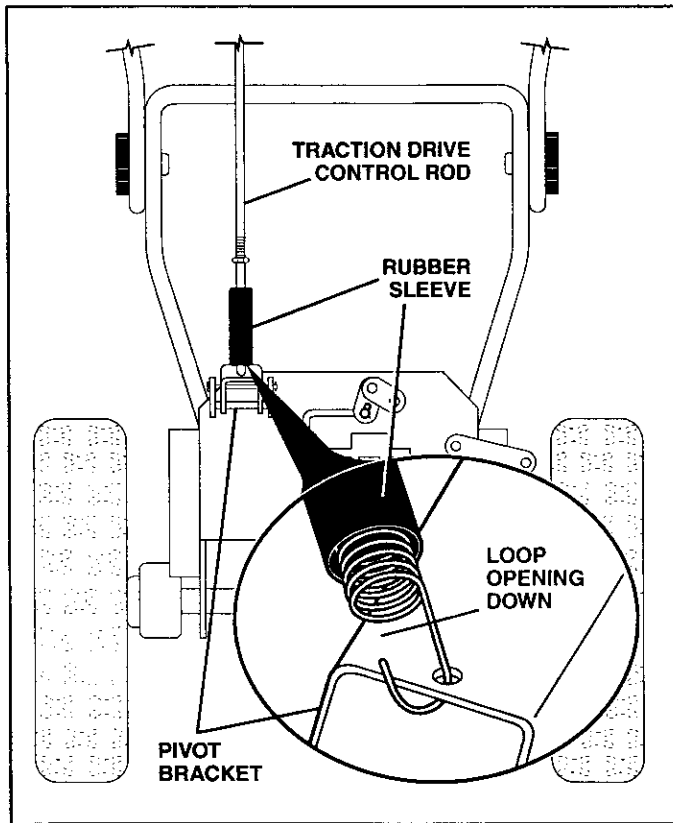

FIG. 3

INSTALL AUGER CONTROL ROD (See Figs. 5 and 6)

The auger control rod has the short loop on the end of the spring as shown.

1. Slide rubber sleeve up rod and hook end of spring into control arm with loop opening up as shown.
2. With top end of rod positioned under right side of control panel, push rod down and insert end of rod into hole in auger control bracket. Secure with retainer spring.

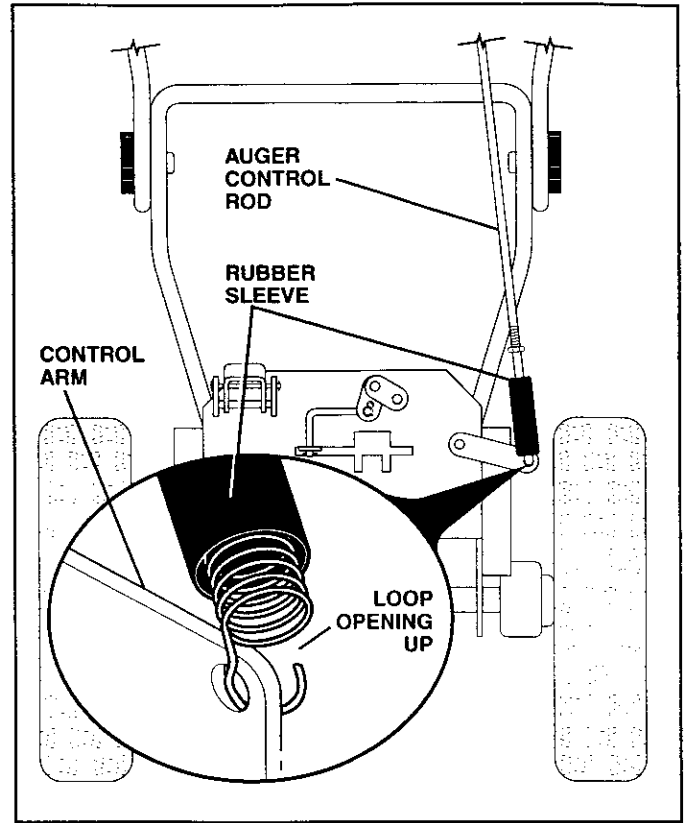

FIG. 5

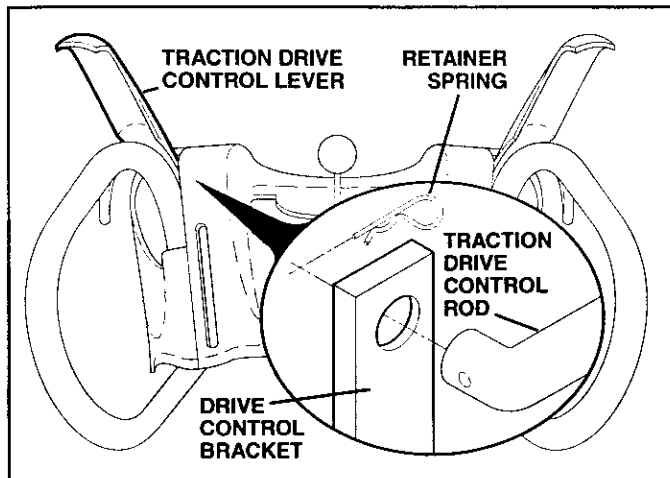

FIG. 4

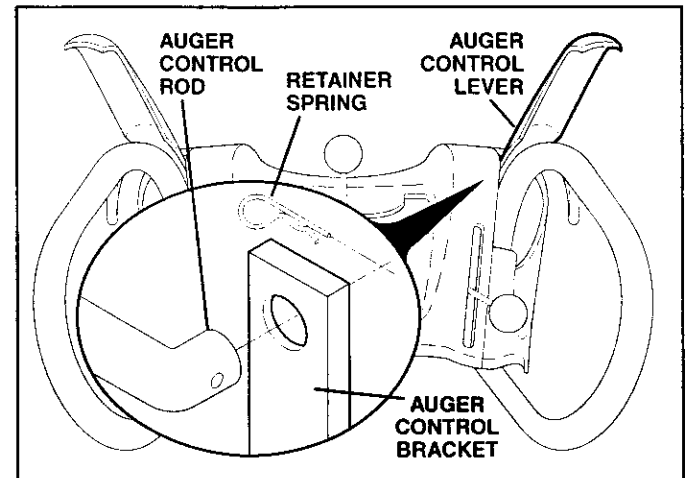

FIG. 6

ASSEMBLY / PRE-OPERATION

INSTALL DISCHARGE CHUTE/CHUTE ROTATER HEAD (See Fig. 7)

NOTE: The multi-wrench provided in your parts bag may be used to install the chute rotater head.

1. Place discharge chute assembly on top of chute base with discharge opening toward front of snow thrower.
2. Position chute rotater head over chute bracket. If necessary, rotate chute assembly to align square and pin on underside of chute rotater head with holes in chute bracket.
3. With chute rotater head and chute bracket aligned, position chute rotater head on pin and threaded stud of mounting bracket.
4. Install 3/8 washer and locknut on threaded stud and tighten securely.

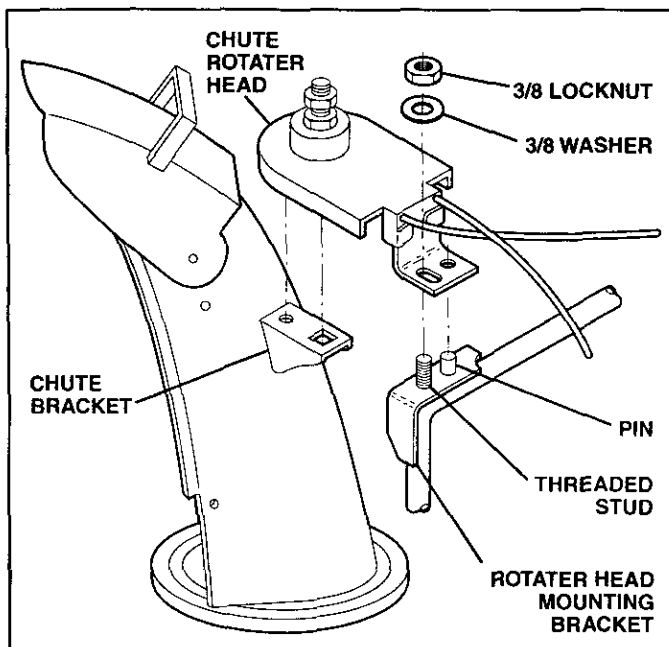

FIG. 7

CHECK TIRE PRESSURE

The tires on your snow thrower were overinflated at the factory for shipping purposes. Correct and equal tire pressure is important for best snow throwing performance.

- Reduce tire pressure to 14-17 PSI.

OPERATION

KNOW YOUR SNOW THROWER

READ THIS OWNER'S MANUAL AND ALL SAFETY RULES BEFORE OPERATING YOUR SNOW THROWER. Compare the illustrations with your snow thrower to familiarize yourself with the location of various controls and adjustments. Save this manual for future reference.

These symbols may appear on your snow thrower or in literature supplied with the product. Learn and understand their meaning.

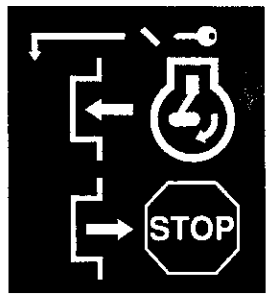
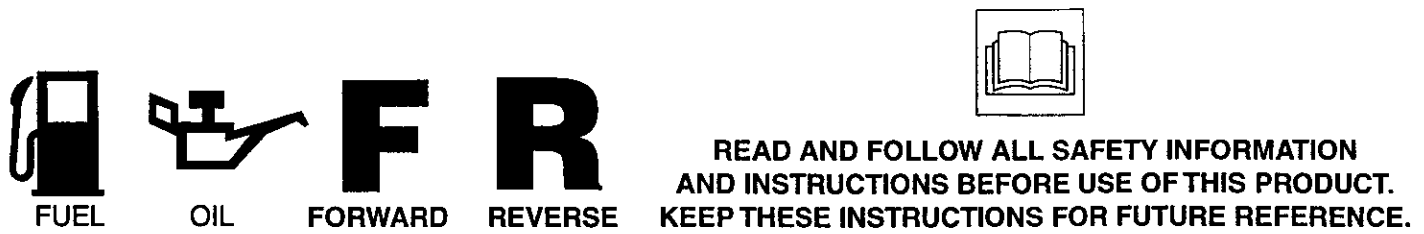
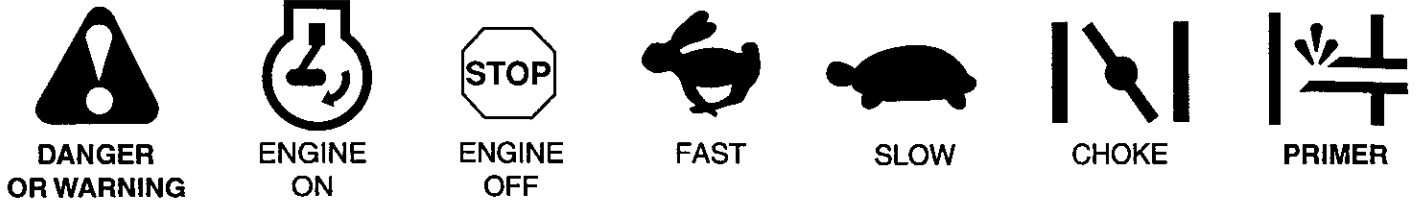

IGNITION KEY.
INSERT TO START
AND RUN,
PULL OUT TO STOP.

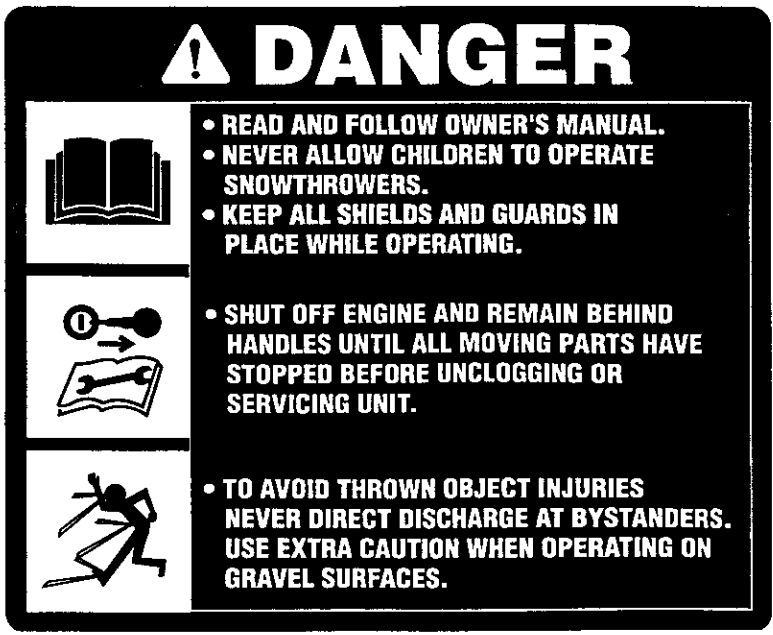
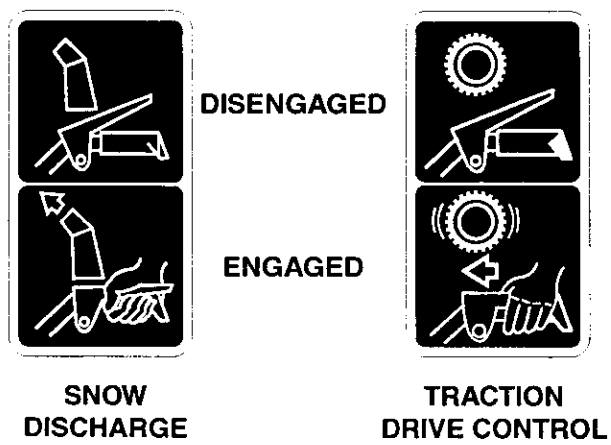

OPERATION

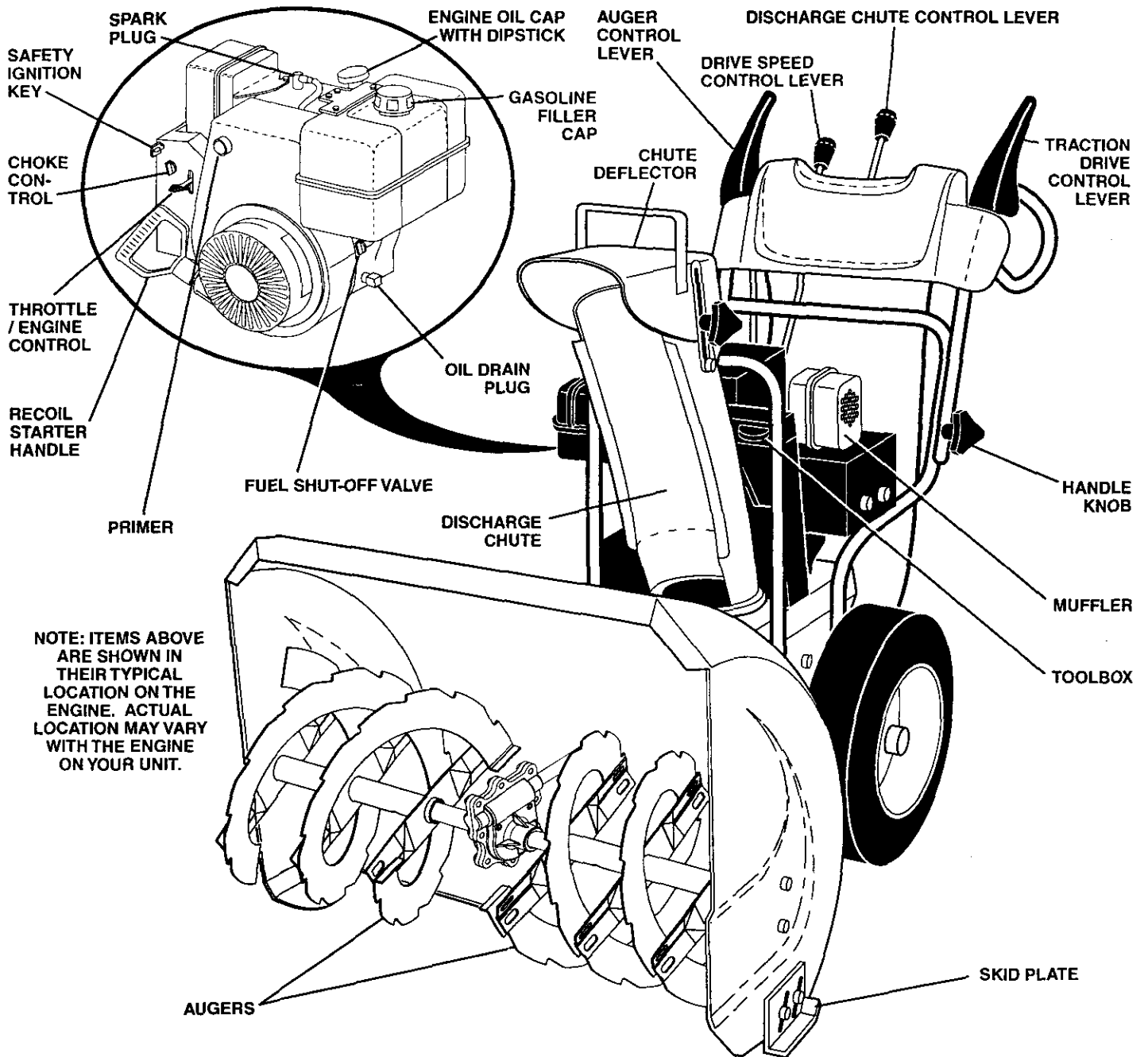

FIG. 8

MEETS A.N.S.I. SAFETY REQUIREMENTS

Our snow throwers conform to the standards of the American National Standards Institute.

Toolbox - used to store spare shear bolts, locknuts and wrench.

Safety ignition key - must be inserted for the engine to start and run. Remove when snow thrower is not in use.

Recoil starter handle - used for starting the engine.

Primer - pumps additional fuel from the carburetor to the cylinder for use when starting a cold engine.

Throttle/engine control - used to select either FAST or SLOW engine speed and to STOP the engine.

Choke control - used for starting a cold engine.

Drive speed control lever - used to select forward or reverse motion and speed of snow thrower.

Traction drive control lever - used to engage power-propelled forward or reverse motion of snow thrower.

Auger control lever - used to engage auger motion (throw snow).

Discharge chute control lever - used to change the direction the snow is thrown.

Skid plate - used to adjust height of scraper bar from the ground.

OPERATION



The operation of any snow thrower can result in foreign objects thrown into the eyes, which can result in severe eye damage. Always wear safety glasses or eye shields while operating your snow thrower or performing any adjustments or repairs. We recommend standard safety glasses or a wide vision safety mask worn over spectacles.

HOW TO USE YOUR SNOW THROWER

Know how to operate all controls before adding fuel or attempting to start the engine.

STOPPING

TRACTION DRIVE

- Release traction drive control lever to stop the forward or reverse movement of the snow thrower.

AUGER

- Release the auger control lever to stop throwing snow.

ENGINE

1. Move throttle control to "STOP" position.
2. Remove (do not turn) safety ignition key to prevent unauthorized use.

NOTE: Never use choke to stop engine.

TO USE FUEL SHUT-OFF VALVE (See Fig. 9)

The fuel shut-off valve is located beneath the fuel tank on the engine. Always operate the snow thrower with the fuel shut-off valve in the OPEN position.

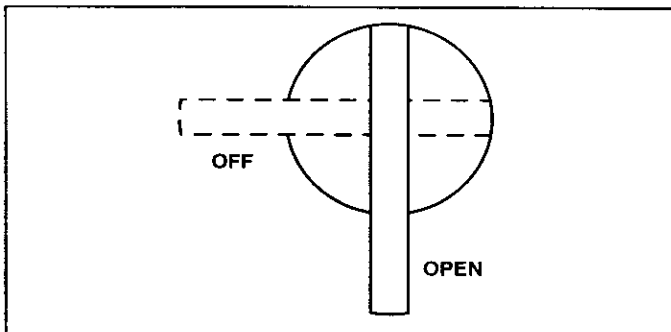

FIG. 9

TO USE THROTTLE CONTROL (See Fig. 10)

The throttle control is located on the engine. Always operate the snow thrower with the engine at full throttle. Full throttle offers the best snow thrower performance.

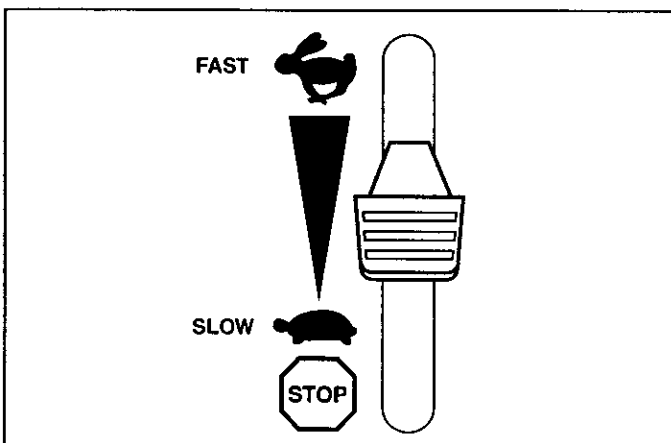

FIG. 10

TO USE CHOKE CONTROL (See Fig. 11)

The choke control is located on the engine. Use the choke control whenever you are starting a cold engine. Do not use to start a warm engine.

- To engage choke, turn knob clockwise. Slowly turn knob counterclockwise to disengage.

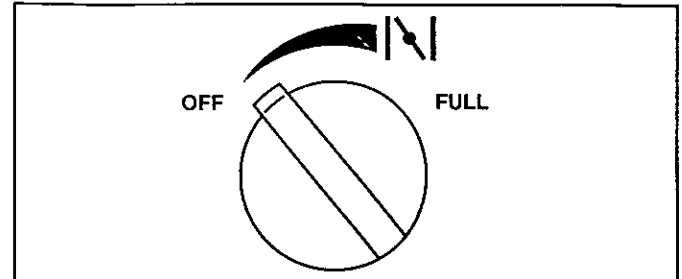

FIG. 11

TO CONTROL SNOW DISCHARGE (See Figs. 12 & 13)



WARNING: Snow throwers have exposed rotating parts, which can cause severe injury from contact, or from material thrown from the discharge chute. Keep the area of operation clear of all persons, small children and pets at all times including startup.



WARNING: If the discharge chute or auger become clogged, shut-off engine and wait for all moving parts to stop. Use a stick, NOT YOUR HANDS, to unclog the chute and/or auger.

The **DIRECTION** in which snow is to be thrown is controlled by the discharge chute control lever.

- To change the discharge chute position, press downward on discharge chute control lever and move lever left or right until chute is in desired position. Be sure lever springs back and locks into desired position.

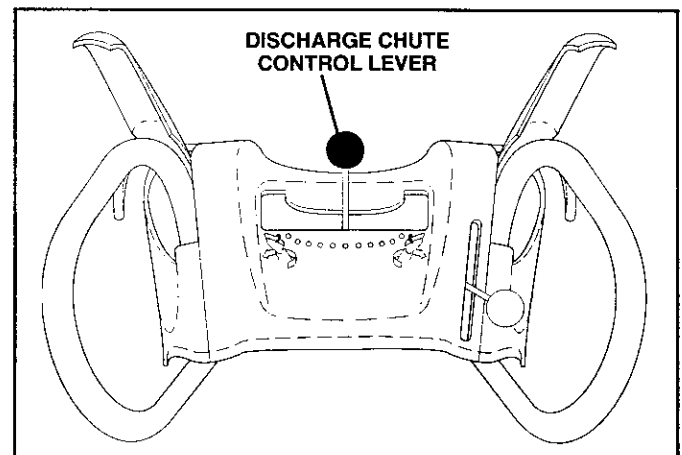

FIG. 12

The **DISTANCE** that snow is thrown is controlled by the position of the chute deflector. Set the deflector low to throw snow a short distance; set the deflector higher to throw snow farther.

- To change the deflector position, loosen knob, move deflector to desired position and tighten knob securely.

OPERATION

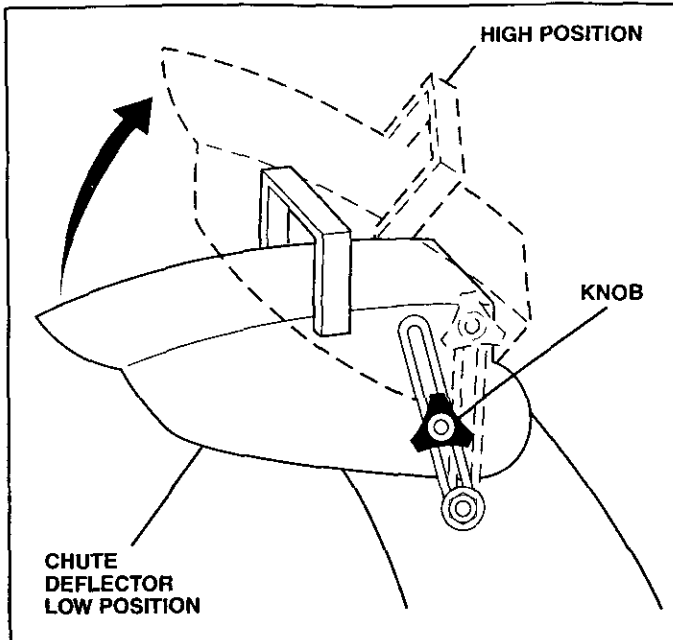

FIG. 13

TO THROW SNOW (See Fig. 14)

The auger rotation is controlled by the auger control lever located on the right side handle.

- Squeeze auger control lever to handle to engage the auger and throw snow.
- Release the auger control lever to stop throwing snow.

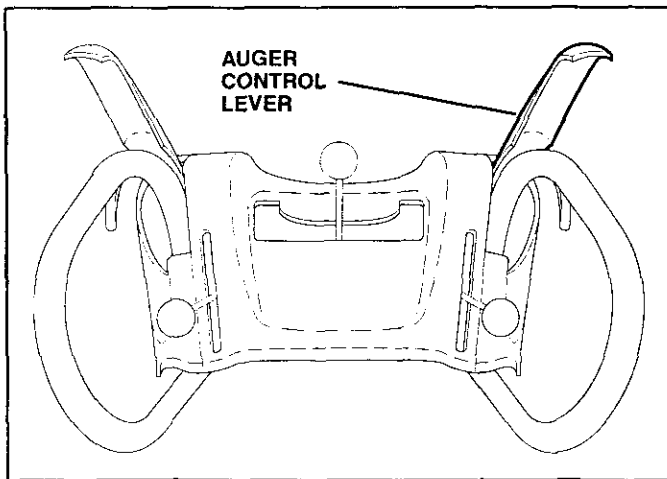

FIG. 14

TO MOVE FORWARD AND BACKWARD (See Fig. 15)

SELF-PROPELLING, forward and reverse movement of the snow thrower, is controlled by the traction drive control lever located on the left side handle.

- Squeeze traction drive control lever to handle to engage the drive system.
- Release traction drive control lever to stop the forward or reverse movement of the snow thrower.

SPEED and DIRECTION are controlled by the drive speed control lever.

- Press downward on the speed control lever and move lever to desired position **BEFORE** engaging the traction drive control lever. Be sure lever springs back and locks into desired position.

CAUTION: Do not move speed control lever when traction drive control lever is engaged. Damage to the snow thrower can result.

- Slower speeds are for heavier snow and faster speeds are for light snow and transporting the snow thrower. It is recommended that you use a slower speed until you are familiar with the operation of the snow thrower.

NOTE: When both traction drive and auger control levers are engaged, the traction drive control lever will lock the auger control lever in the engaged position. This will allow you to release your right hand from the handle and adjust the discharge chute direction without interrupting the snow throwing process.

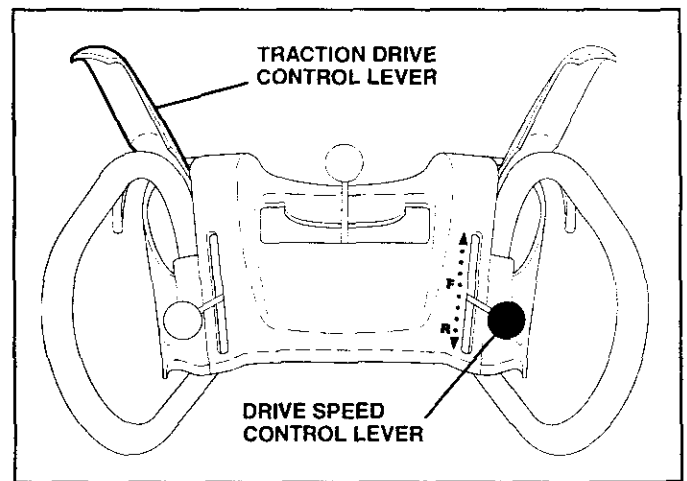

FIG. 15

OPERATION

TO ADJUST SKID PLATES (See Fig. 16)

NOTE: The wrench provided in your parts bag may be used to adjust the skid plates.

Skid plates are located on each side of the auger housing and adjust the clearance between the scraper bar and the ground surface. Adjust skid plates evenly to proper height for current surface conditions. For removal of snow in normal conditions, such as a paved driveway or sidewalk, place skid plates in the highest position (lowest scraper clearance) to give a 1/8" clearance between the scraper bar and the ground. Use a middle position if the surface to be cleared is uneven.

NOTE: It is not recommended to operate the snow thrower over gravel or rocky surfaces. Objects such as gravel, rocks or other debris, can easily be picked up and thrown by the impeller, which can cause serious personal injury, property damage or damage to the snow thrower.

- If snow thrower must be operated over gravel surface, use extra caution and be sure skid plates are adjusted to lowest (highest scraper clearance) position.
1. Shut off engine and wait for all moving parts to stop.
 2. Adjust skid plates by loosening the rear 1/2" hex nut only, then moving skid plate to desired position. Be sure both plates are adjusted evenly. Tighten securely.

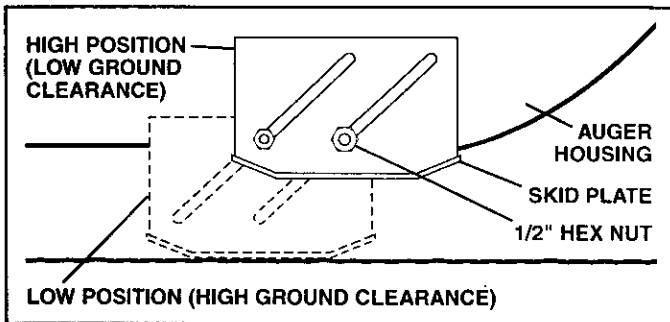

FIG. 16

SCRAPER BAR

The scraper bar is not adjustable, but is reversible. After considerable use it may become worn. When it has worn almost to the edge of the housing, it can be reversed, providing additional service before requiring replacement. Replace a damaged or worn scraper bar.

BEFORE STARTING THE ENGINE

CHECK ENGINE OIL LEVEL (See Fig. 17)

The engine on your snow thrower has been shipped, from the factory, already filled with oil.

1. Check engine oil with snow thrower on level ground.
 2. Remove oil fill cap/dipstick and wipe clean, reinsert the dipstick and screw tight, wait for a few seconds, remove and read oil level. If necessary, add oil until "FULL" mark on dipstick is reached. Do not overfill.
- To change engine oil, see "TO CHANGE ENGINE OIL" in the Maintenance section of this manual.

ADD GASOLINE (See Fig. 17)

- Fill fuel tank to bottom of tank filler neck. Do not overfill. Use fresh, clean, regular unleaded gasoline with a minimum of 87 octane. Do not mix oil with gasoline. Purchase fuel in quantities that can be used within 30 days to assure fuel freshness.



WARNING: Wipe off any spilled oil or fuel. Do not store, spill or use gasoline near an open flame.

CAUTION: Alcohol blended fuels (called gasohol or using ethanol or methanol) can attract moisture which leads to separation and formation of acids during storage. Acidic gas can damage the fuel system of an engine while in storage. To avoid engine problems, the fuel system should be emptied before storage of 30 days or longer. Empty the gas tank, start the engine and let it run until the fuel lines and carburetor are empty. Use fresh fuel next season. See Storage Instructions for additional information. Never use engine or carburetor cleaner products in the fuel tank or permanent damage may occur.

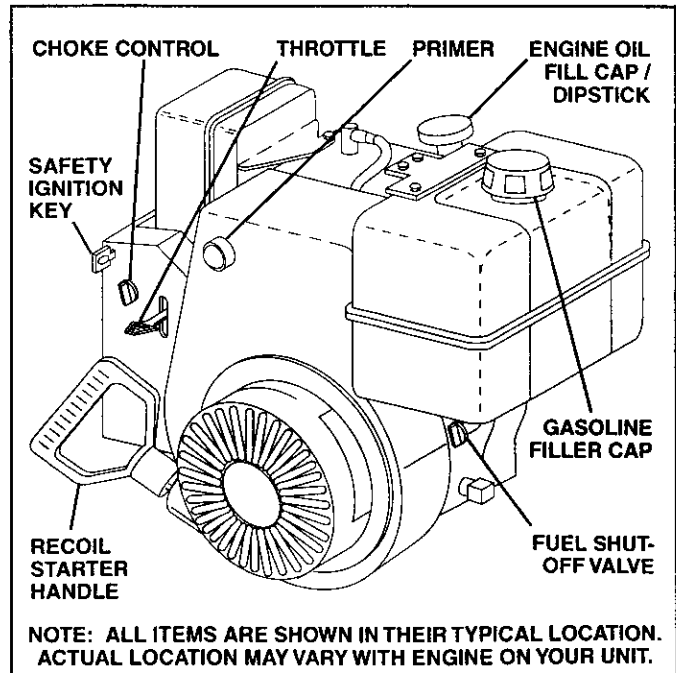

NOTE: ALL ITEMS ARE SHOWN IN THEIR TYPICAL LOCATION. ACTUAL LOCATION MAY VARY WITH ENGINE ON YOUR UNIT.

FIG. 17

OPERATION

TO START ENGINE

- Be sure fuel shut-off valve is in the OPEN position.

Your snow thrower engine is equipped with a recoil starter.

COLD START

1. Insert safety ignition key into the ignition slot until it clicks. DO NOT turn the key. Keep the extra safety ignition key in a safe place.
2. Place throttle control in FAST position.
3. Rotate choke control to FULL position.
4. Push the primer four (4) times if the temperature is below 15°F, or two (2) times if temperature is between 15° and 50°F. If temperature is above 50°F, priming is not necessary.

NOTE: Over priming may cause flooding, preventing the engine from starting. If you do flood the engine, wait a few minutes before attempting to start and DO NOT push the primer.

5. Pull recoil starter handle quickly. Do not allow starter rope to snap back.
6. When the engine starts, release the recoil starter handle and slowly move the choke control to the OFF position.

Allow the engine to warm up for a few minutes. Engine will not develop full power until it has reached normal operating temperature.

WARM START

Follow the steps above, keeping the choke in the OFF position. DO NOT push the primer.

BEFORE STOPPING

Run the engine for a few minutes to help dry off any moisture on the engine.

To avoid possible freeze-up of the starter, proceed as follows:

1. While the engine is running, pull the recoil starter handle with rapid, full arm strokes three or four times.

NOTE: The unusual sound made while pulling the recoil starter handle will not harm the engine or starter.

IF RECOIL STARTER HAS FROZEN

If the recoil starter has frozen and will not turn the engine, proceed as follows:

1. Grasp the recoil starter handle and slowly pull as much rope out of the starter as possible.
2. Release the recoil starter handle and let it snap back against the starter.

If the engine still fails to start, repeat the above steps.

SNOW THROWING TIPS

- Always operate the snow thrower with the engine at full throttle. Full throttle offers the best performance.
- Go slower in deep, freezing or heavy wet snow. Use the drive speed control, NOT the throttle, to adjust speed.
- It is easier and more efficient to remove snow immediately after it falls.
- The best time to remove snow is the early morning. At this time the snow is usually dry and has not been exposed to the direct sun and warming temperatures.
- Slightly overlap each successive path to ensure all snow will be removed.
- Throw snow downwind whenever possible.
- Adjust the skid plates to proper height for current snow conditions. See "TO ADJUST SKID PLATES" in this section of this manual.
- For extremely heavy snow, reduce the width of snow removal by overlapping previous path and moving slowly.
- Keep engine clean and clear of snow during use. This will help air flow and extend engine life.
- After snow-throwing is completed, allow engine to run for a few minutes to melt snow and ice off the engine.
- Clean the entire snow thrower thoroughly after each use and wipe dry so it is ready for next use.



WARNING: Do not operate snow thrower if weather conditions impair visibility. Throwing snow during a heavy, windy snowstorm can blind you and be hazardous to the safe operation of the snow thrower.

MAINTENANCE

V-BELTS

Check V-belts for deterioration and wear after every 50 hours of operation and replace if necessary. The belts are not adjustable. Replace belts if they begin to slip from wear. (See "TO REMOVE BELT COVER" in the Service and Adjustments section of this manual).

The V-belts on your snow thrower are of special construction and should be replaced by original equipment manufacturer (OEM) belts available from your nearest dealer. Using other than OEM belts can cause personal injury or damage to the snow thrower.

AUGER GEAR CASE

- The gear case was filled with lubricant to the proper level at the factory. The only time the lubricant needs attention is if service has been performed on the gear case.
- If lubricant is required, use only Ronex ED #1 grease.

TRACTION DRIVE SYSTEM

DO NOT lubricate the drive components inside the snow thrower. The sprockets, hex shafts, drive disc and friction wheel require no lubrication. The bearings and bushings are lifetime lubricated and require no maintenance.

CAUTION: Any lubricating of the above components can cause contamination of the friction wheel and damage to the drive system of your snow thrower.

ENGINE

See engine manual.

LUBRICATION

Use only high quality detergent oil rated with API service classification SF-SJ. Select the oil's SAE viscosity grade according to your expected operating temperature.

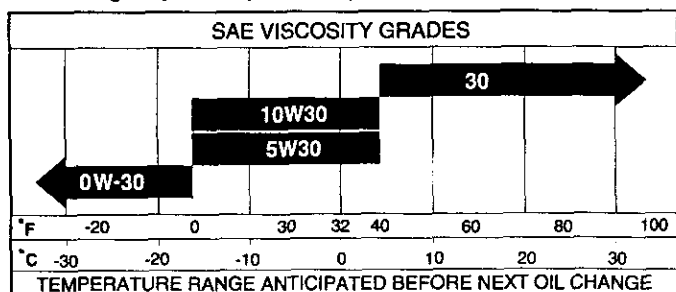

NOTE: Although multi-viscosity oils (5W30, 10W30 etc.) improve starting in cold weather, these multi-viscosity oils will result in increased oil consumption when used above 32°F. Check your engine oil level more frequently to avoid possible engine damage from running low on oil.

Change the oil after every 50 hours of operation or at least once a year if the snow thrower is not used for 50 hours in one year.

Check the crankcase oil level before starting the engine and after each five (5) hours of continuous use. Tighten oil fill cap / dipstick securely each time you check the oil level.

TO CHANGE ENGINE OIL

Determine temperature range anticipated before next oil change. All oil must meet API service classification SF-SJ.

- Be sure snow thrower is on level surface.
- Oil will drain more freely when warm.
- Catch oil in a suitable container.

NOTE: The left side wheel may be removed from snow thrower for easier access to the oil drain plug and placement of a suitable container. The unit tilted, resting on the frame with the left wheel removed, will help drain any oil trapped inside the engine. (See "TO REMOVE WHEELS" in the Service and Adjustments section of this manual).

1. Disconnect spark plug wire from spark plug and place wire where it cannot come in contact with spark plug.
2. Clean area around drain plug.
3. Remove drain plug and drain oil in a suitable container.
4. Install drain plug and tighten securely.
5. Wipe off any spilled oil from snow thrower and engine.
6. Install left wheel (if removed for draining oil). Be sure to install klick pin into proper hole in wheel axle (See "TO REMOVE WHEELS" in the Service and Adjustments section of this manual).
7. Remove oil fill cap/dipstick. Be careful not to allow dirt to enter the engine.
8. Refill engine with oil through oil dipstick tube. Pour slowly. Do not overfill. For approximate capacity see "PRODUCT SPECIFICATIONS" section of this manual.
9. Use gauge on oil fill cap/dipstick for checking level. Be sure dipstick cap is tightened securely for accurate reading. Keep oil at "FULL" line on dipstick.
10. Wipe off any spilled oil.

MUFFLER

Inspect and replace corroded muffler as it could create a fire hazard and/or damage.

SPARK PLUG

Replace spark plug at the beginning of each season or after every 100 hours of operation, whichever occurs first. Spark plug type and gap setting are shown in the "PRODUCT SPECIFICATIONS" section of this manual.

CLEANING

IMPORTANT: For best performance, keep snow thrower housing free of any dirt or trash. Clean the outside of your snow thrower after each use.



WARNING: Disconnect spark plug wire from spark plug and place wire where it cannot come in contact with spark plug.

- Keep finished surfaces/wheels free of gasoline, oil, etc.
- We do not recommend using a garden hose to clean your snow thrower unless the electrical system, muffler and carburetor are covered to keep water out. Water in engine can result in shortened engine life.

SERVICE AND ADJUSTMENTS

WARNING: To avoid serious injury, before performing any service or adjustments:



1. Be sure throttle is in STOP position.
2. Remove safety ignition key.
3. Make sure the augers and all moving parts have completely stopped.
4. Disconnect spark plug wire from spark plug and place wire where it cannot come in contact with plug.

SNOW THROWER

TO ADJUST SNOW THROWER HEIGHT

See "TO ADJUST SKID PLATES" and "SCRAPER BAR" in the Operation section of this manual.

CHUTE DEFLECTOR

The chute deflector, attached to the top of the discharge chute, is provided to direct discharging snow away from the operator. If the deflector becomes damaged, it should be replaced.



WARNING: To avoid serious injury, never operate your snow thrower with the deflector removed or damaged.

- To change direction and/or distance snow is discharged, see "TO CONTROL SNOW DISCHARGE" in the Operation section of this manual.

SHEAR BOLTS (See Fig. 18)

AUGER SHEAR BOLTS

Both right and left-hand augers are secured to the auger shaft with a shoulder/shear bolt and hex nut. Should a foreign object or ice become lodged in the augers, the shear bolts are designed to break, preventing damage to any other components. If one or both augers do not turn when auger control lever is engaged, check to see if one or both of the bolts have sheared. To replace the shear bolts:

1. Disengage all controls and move throttle control to STOP position. Wait for all moving parts to stop.
2. Disconnect spark plug wire from spark plug and place it where it cannot come in contact with spark plug.
3. Align hole in auger hub with hole in auger shaft and install a new 1/4-20 x 2" shoulder/shear bolt. Install 1/4-20 lock nut and tighten securely.

CAUTION: Do not substitute. Use only original equipment shear bolts as supplied with your snow thrower.

4. Connect spark plug wire to spark plug.

IMPELLER SHEAR BOLTS

The impeller is secured to the impeller shaft with two (2) capscrew/shear bolts and hex nuts. Should a foreign object or ice become lodged in the impeller, the capscrews are designed to break, preventing damage to any other components. If impeller does not turn when auger control lever is engaged, check to see if the capscrews have sheared. To replace the capscrew/shear bolts:

1. Disengage all controls and move throttle control to STOP position. Wait for all moving parts to stop.
2. Disconnect spark plug wire from spark plug and place it where it cannot come in contact with spark plug.
3. Align holes in impeller hub with holes in impeller shaft and install two (2) new 1/4-20 x 1-5/8" capscrew/shear bolts. Install 1/4-20 locknuts and tighten securely.

CAUTION: Do not substitute. Use only original equipment capscrew/shear bolts as supplied with your snow thrower.

4. Connect spark plug wire to spark plug.

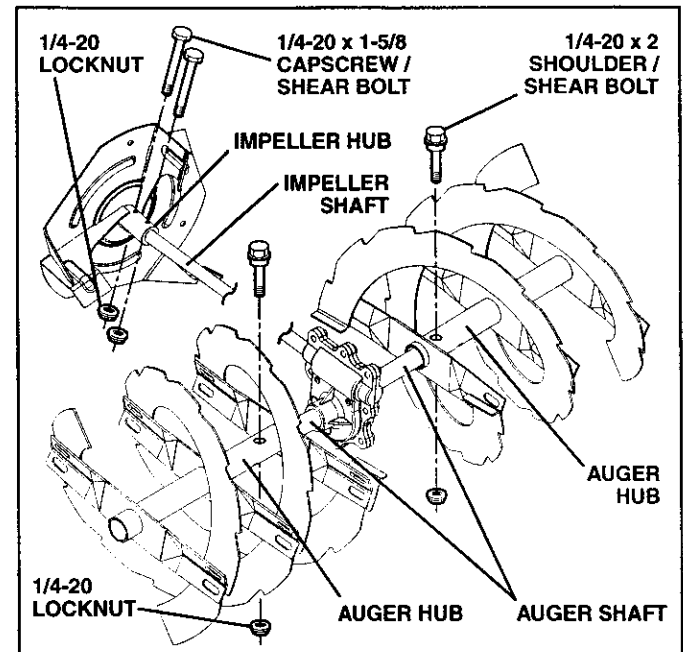

FIG. 18

TO REMOVE BELT COVER (See Fig. 19)

1. Remove the two (2) screws securing belt cover to frame.
 2. Remove belt cover.
- Replace belt cover by installing cover and screws and tighten securely.

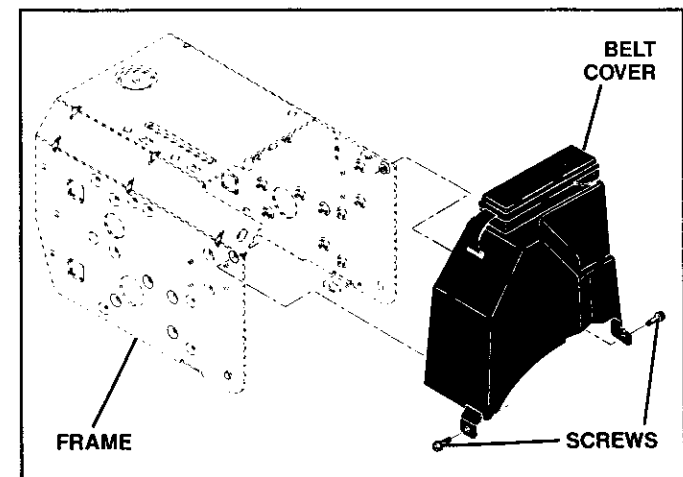

FIG. 19

SERVICE AND ADJUSTMENTS

TO REPLACE BELTS (See Fig. 20)

The auger and traction drive belts are not adjustable. If the belts are damaged or begin to slip from wear, they should be replaced. It is recommended that the belt(s) be replaced by a qualified service center.

NOTE: It is recommended that both the auger and traction drive belt be replaced at the same time.

The V-belts on your snow thrower are of special construction and should be replaced by original equipment manufacturer (OEM) belts available from your nearest dealer. Using other than OEM belts can cause personal injury or damage to the snow thrower.

WARNING: Belt replacement requires separation of the snow thrower. While separating the auger housing from the frame assembly, it is important that an assistant stand in the operating position and hold the snow thrower handles. Serious personal injury and/or damage to the unit could occur if the snow thrower should fall during the belt changing process.



FRAME ASSEMBLY

AUGER HOUSING

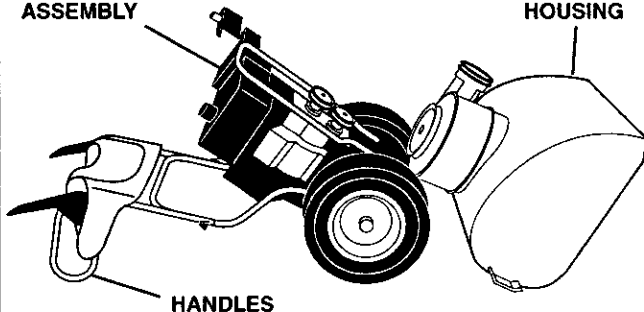

HANDLES

1. REMOVE GASOLINE FROM FUEL TANK - Drain gasoline from fuel tank into a suitable container, outdoors, away from fire or flame. Wipe up any spilled gasoline.
2. REMOVE DISCHARGE CHUTE - Loosen locknut securing chute rotator head to mounting bracket only enough to allow chute rotator head to be raised and discharge chute to be removed from snow thrower.
3. REMOVE BELT COVER - See "TO REMOVE BELT COVER" in this section of this manual.
4. REMOVE ENGINE PULLEY - Remove bolt, lockwasher and flat washer securing pulley to engine crankshaft. Remove outside (auger) pulley only from crankshaft.
5. SEPARATE SNOW THROWER - With your assistant standing in the operating position holding the handles, remove the two (2) bolts and lock washers holding auger housing and frame together.



WARNING: As the last bolt is removed, have your assistant carefully lower the handles down to the ground.

6. REMOVE AUGER BELT from around pulley.
7. RELIEVE TENSION ON TRACTION DRIVE BELT IDLER and remove traction drive belt from around pulleys.

HINT: Insert a 3/8" drive ratchet (in the "ON" position) into the square hole in idler arm and rotate ratchet clockwise to relieve tension.

8. With tension relieved on idler, install new traction drive belt around pulleys and inside belt keepers.
9. Place auger belt around and inside the groove of auger pulley only.
10. While your assistant slowly raises handles to rejoin the auger housing and frame assembly, pull up on the auger belt and squeeze sides together above pulley so belt is fully seated in groove of pulley.
11. Bring snow thrower completely together and check carefully for proper routing of belts. If auger belt has become dislodged from the pulley (by catching the idler arm bracket while bringing snow thrower together), separate the snow thrower and repeat step 10. Belt must be fully seated in pulley groove when bringing the snow thrower together.
12. Install the two (2) hex bolts and lock washers and tighten securely.
13. INSTALL ENGINE PULLEY - Place belt in pulley groove and slide pulley on crankshaft. Install flat washer, lockwasher and bolt and tighten securely (30-35 ft. lbs. torque). Make sure belt is inside belt keeper.
14. INSTALL BELT COVER and two (2) screws. Tighten securely.
15. INSTALL DISCHARGE CHUTE - See "INSTALL DISCHARGE CHUTE / CHUTE ROTATER HEAD" in the Assembly / Pre-Operation section of this manual.

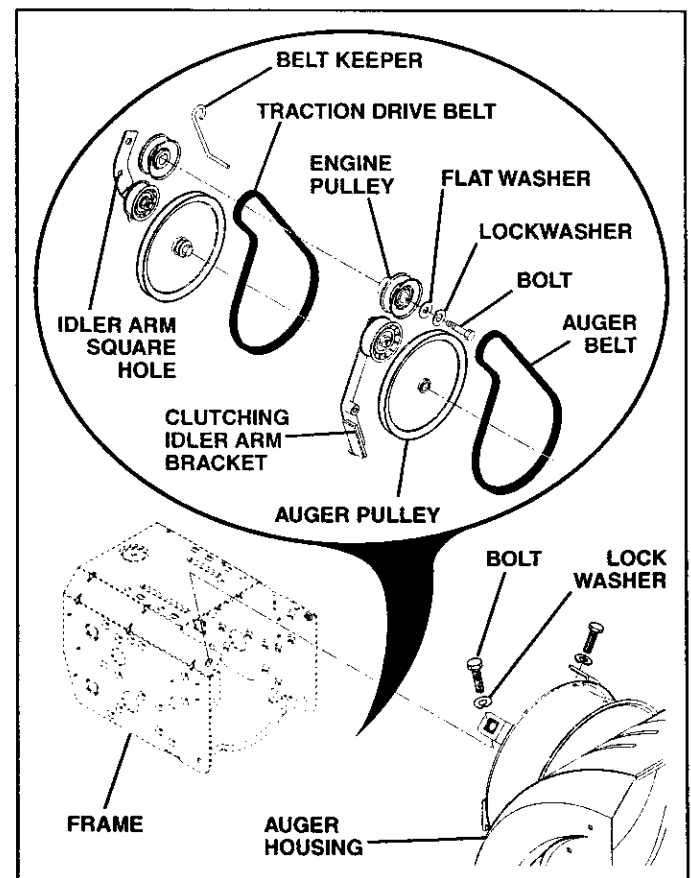

FIG. 20

TO REMOVE WHEELS (See Fig. 21)

- Remove the klik pin and remove wheel from axle.

IMPORTANT: When installing wheel, be sure to use the innermost hole in axle and the wheel hub hole. To disengage drive system from the wheels (for pushing or transporting the snow thrower), remove klik pin from wheel hub and insert pin into the outermost hole in axle only.

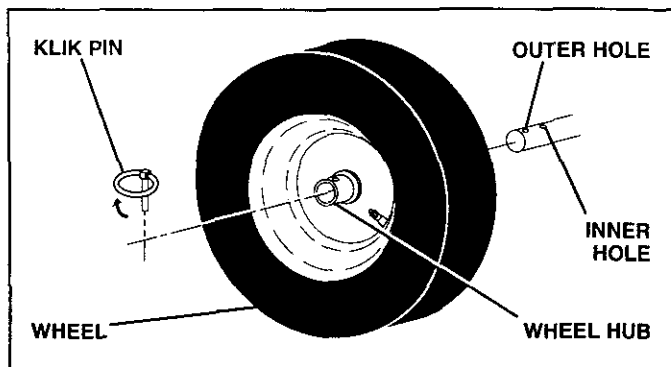

FIG. 21

NOTE: To seal punctures or prevent flat tires due to slow leaks, tire sealant may be purchased from your local parts dealer. Tire sealant also prevents tire dry rot and corrosion.

ENGINE

See engine manual.

CARBURETOR

Your carburetor is not adjustable. Engine performance should not be affected at altitudes up to 7,000 feet (2,134 meters). If your engine does not operate properly due to suspected carburetor problems, take your snow thrower to a qualified service center.

ENGINE SPEED

Never tamper with the engine governor, which is factory set for proper engine speed. Overspeeding the engine above the factory high speed setting can be dangerous and will void the warranty. If you think the engine-governed high speed needs adjusting, contact a qualified service center, which has proper equipment and experience to make any necessary adjustments.

STORAGE

Immediately prepare your snow thrower for storage at the end of the season or if the unit will not be used for 30 days or more.



WARNING: Never store the snow thrower with gasoline in the tank inside a building where fumes may reach an open flame, spark or pilot light as on a furnace, water heater, clothes dryer or gas appliance. Allow the engine to cool before storing in any enclosure.

SNOW THROWER

When snow thrower is to be stored for a period of time, clean it thoroughly, remove all dirt, grease, leaves, etc. Store in a clean, dry area.

1. Clean entire snow thrower (See "CLEANING" in the Maintenance section of this manual).
2. Inspect and replace belts, if necessary (See "TO REPLACE BELTS" in the Service and Adjustments section of this manual).
3. Lubricate as shown in the Maintenance section of this manual.
4. Be sure that all nuts, bolts, screws, and pins are securely fastened. Inspect moving parts for damage, breakage and wear. Replace if necessary.
5. Touch up all rusted or chipped paint surfaces; sand lightly before painting.

ENGINE

See engine manual.

FUEL SYSTEM

IMPORTANT: It is important to prevent gum deposits from forming in essential fuel system parts such as carburetor, fuel hose, or tank during storage. Also, alcohol blended fuels (called gasohol or using ethanol or methanol) can attract moisture which leads to separation and formation of acids during storage. Acidic gas can damage the fuel system of an engine while in storage.

- Empty the fuel tank by starting the engine and letting it run until the fuel lines and carburetor are empty.
- Never use engine or carburetor cleaner products in the fuel tank or permanent damage may occur.
- Use fresh fuel next season.

NOTE: Fuel stabilizer is an acceptable alternative in minimizing the formation of fuel gum deposits during storage. Add stabilizer to gasoline in fuel tank or storage container. Always follow the mix ratio found on stabilizer container. Run engine at least 10 minutes after adding stabilizer to allow the stabilizer to reach the carburetor. Do not empty the gas tank and carburetor if using fuel stabilizer.

ENGINE OIL

Drain oil (with engine warm) and replace with clean engine oil. (See "ENGINE" in the Maintenance section of this manual).

CYLINDER

1. Remove spark plug.
2. Pour one ounce (29 ml) of oil through spark plug hole into cylinder.
3. Pull recoil starter handle slowly a few times to distribute oil.
4. Replace with new spark plug.

OTHER

- Do not store gasoline from one season to another.
- Replace your gasoline can if your can starts to rust. Rust and/or dirt in your gasoline will cause problems.
- If possible, store your snow thrower indoors and cover it to protect it from dust and dirt.
- Cover your snow thrower with a suitable protective cover that does not retain moisture. Do not use plastic. Plastic cannot breathe, which allows condensation to form and will cause your snow thrower to rust.

IMPORTANT: Never cover snow thrower while engine/exhaust area is still warm.

TROUBLESHOOTING

See appropriate section in manual unless directed to a qualified service center.

| PROBLEM | CAUSE | CORRECTION |
|------------------------------------------------------------|---------------------------------------------------------------------------------------------------------------------------------------------------------------------------------------------------------------------------------------------------------------------------------------------------------------------------------------------------------------------------------------------------------------------------------------------------------------|----------------------------------------------------------------------------------------------------------------------------------------------------------------------------------------------------------------------------------------------------------------------------------------------------------------------------------------------------------------------------------------------------------------------------------------------------------------------------------------------------------------------------------------------------------------------------------------------------------------------------------------------------------------------|
| Does not start | <ol style="list-style-type: none"> 1. Fuel shut-off valve (if so equipped) in OFF position. 2. Safety ignition key is not inserted. 3. Out of fuel. 4. Throttle in STOP position. 5. Choke in OFF position. 6. Primer not depressed. 7. Engine is flooded. 8. Spark plug wire is disconnected. 9. Bad spark plug. 10. Stale fuel. 11. Water in fuel. | <ol style="list-style-type: none"> 1. Turn fuel shut-off valve to OPEN position. 2. Insert safety ignition key. 3. Refill fuel tank with fresh, clean gasoline. 4. Move throttle to FAST position. 5. Move to FULL position. 6. Prime as instructed in the Operation section of this manual. 7. Wait a few minutes before restarting, DO NOT prime. 8. Connect wire to spark plug. 9. Replace spark plug. 10. Empty fuel tank & carburetor, refill with fresh, clean gasoline. 11. Empty fuel tank & carburetor, refill with fresh, clean gasoline. |
| Loss of power | <ol style="list-style-type: none"> 1. Spark plug wire loose. 2. Throwing too much snow. 3. Fuel tank cap is covered with ice or snow. 4. Dirty or clogged muffler. | <ol style="list-style-type: none"> 1. Reconnect spark plug wire. 2. Reduce speed and width of swath. 3. Remove ice and snow on and around fuel tank cap. 4. Clean or replace muffler. |
| Engine idles or runs roughly | <ol style="list-style-type: none"> 1. Choke is in FULL position. 2. Blockage in fuel line. 3. Stale fuel. 4. Water in fuel. 5. Carburetor is in need of adjustment or overhaul. | <ol style="list-style-type: none"> 1. Move choke to OFF position. 2. Clean fuel line. 3. Empty fuel tank & carburetor, refill with fresh, clean gasoline. 4. Empty fuel tank & carburetor, refill with fresh, clean gasoline. 5. Contact a qualified service center. |
| Excessive vibration | <ol style="list-style-type: none"> 1. Loose parts or damaged augers or impeller. | <ol style="list-style-type: none"> 1. Tighten all fasteners. Replace damaged parts. If vibration remains, contact a qualified service center. |
| Recoil starter is hard to pull | <ol style="list-style-type: none"> 1. Frozen recoil starter. | <ol style="list-style-type: none"> 1. See "IF RECOIL STARTER HAS FROZEN" in the Operation section of this manual. |
| Loss of traction drive / slowing of drive speed | <ol style="list-style-type: none"> 1. Drive belt is worn. 2. Drive belt is off of pulley. 3. Friction drive wheel is worn. | <ol style="list-style-type: none"> 1. Check / replace drive belt. 2. Check / reinstall drive belt. 3. Contact a qualified service center. |
| Loss of snow discharge or slowing of snow discharge | <ol style="list-style-type: none"> 1. Auger belt is off of pulley. 2. Auger belt is worn. 3. Clogged discharge chute. 4. Augers / impeller jammed. | <ol style="list-style-type: none"> 1. Check / reinstall auger belt. 2. Check / replace auger belt. 3. Clean snow chute. 4. Remove debris or foreign object from augers / impeller. |

REPAIR PARTS

SNOW THROWER - MODEL NUMBER PP524A

AUGER HOUSING / IMPELLER ASSEMBLY

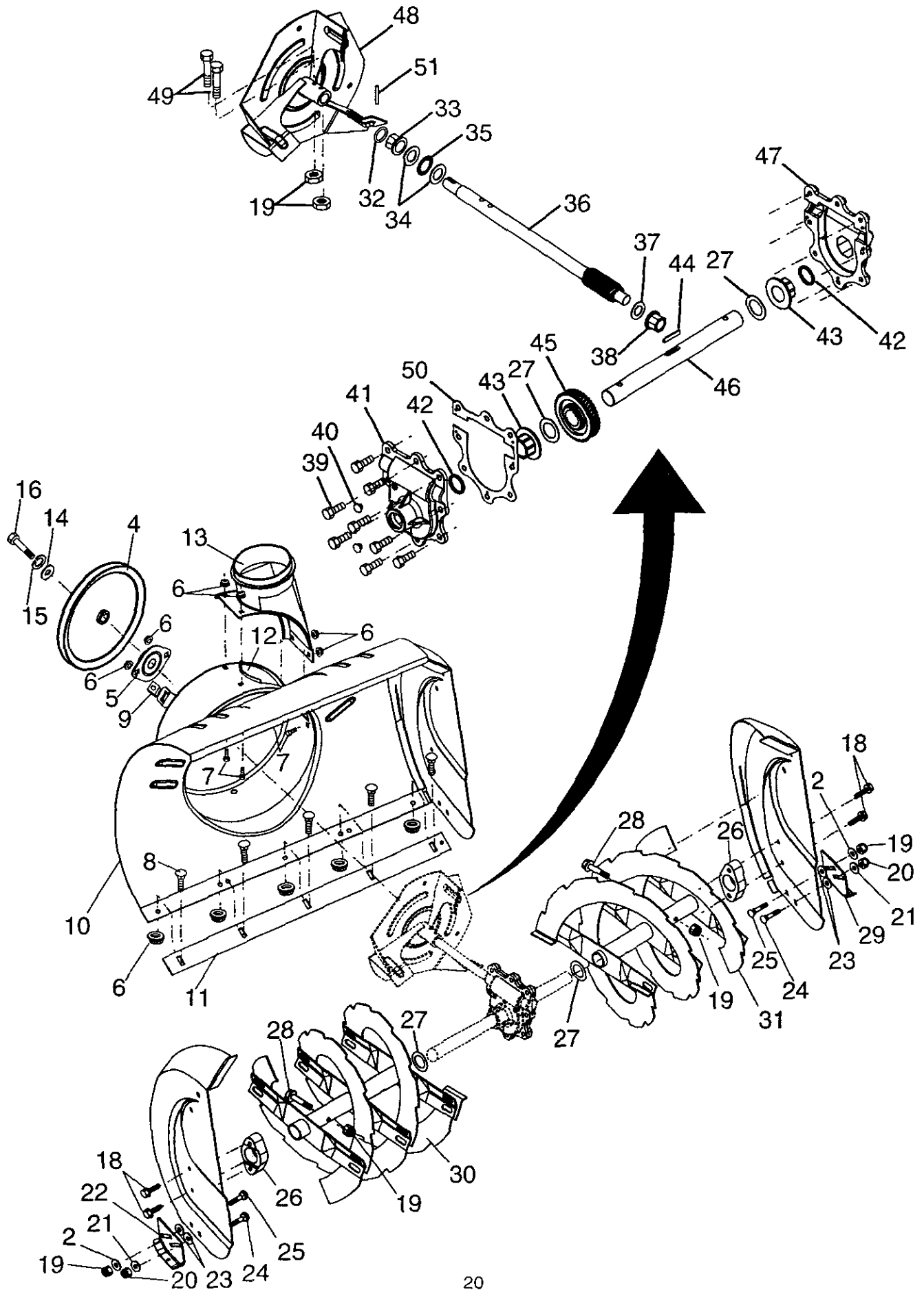

REPAIR PARTS**SNOW THROWER - MODEL NUMBER PP524A****AUGER HOUSING / IMPELLER ASSEMBLY**

| KEY NO. | PART NO. | DESCRIPTION |
|---------|------------|-----------------------------------------|
| 2 | 53847 | Washer |
| 4 | 181083 | Pulley, Impeller |
| 5 | 175323 | Bearing Assembly, Flange |
| 6 | 155377 | Nut, Hex Flange 5/16-18 |
| 7 | 180355 | Bolt, Flat Head, Carriage 5/16-18 x 5/8 |
| 8 | 72270505 | Bolt, Carriage 5/16-18 x 5/8 |
| 9 | 178820 | Nut, Cage 3/8-16 |
| 10 | 175309X428 | Housing, Auger |
| 11 | 174838X479 | Bar, Scraper |
| 12 | 178675X008 | Bracket, Corner Discharge |
| 13 | 175322 | Base, Discharge Chute |
| 14 | 19111507 | Washer, Flat |
| 15 | 10040500 | Washer, Lock 5/16 |
| 16 | 74950512 | Screw, Hex Head 5/16-18 x 3/4 |
| 18 | 179582 | Screw, Hex Head 5/16 x 1 |
| 19 | 73800400 | Nut, Hex Lock 1/4-20 |
| 20 | 73800500 | Nut, Hex Lock 5/16-18 |
| 21 | 155415 | Washer, Flat |
| 22 | 178777X479 | Skid Plate, RH |
| 23 | 179246 | Washer, Nylon, Friction |
| 24 | 72270506 | Bolt, Carriage 5/16-18 x 3/4 |
| 25 | 185600 | Bolt, Shoulder |
| 26 | 174658 | Bearing, Auger |
| 27 | 174697 | Washer, Thrust, 1" |
| 28 | 187494 | Bolt, Shear |
| 29 | 174762X479 | Skid Plate, LH |
| 30 | 175319X479 | Auger Assembly, RH |
| 31 | 175313X479 | Auger Assembly, LH |
| 32 | 174699 | O-Ring |
| 33 | 174700 | Bushing, Flange 3/4 |
| 34 | 174681 | Washer, Thrust 3/4 |
| 35 | 174684 | Bearing, Thrust 3/4 |
| 36 | 174660 | Shaft, Impeller |
| 37 | 174683 | Washer, Thrust 5/8 |
| 38 | 174686 | Bushing, Flange 5/8 |
| 39 | 150078 | Screw, Hex Head 5/16-18 x 3/4 |
| 40 | 86447 | Plug, Case |
| 41 | 174688 | Housing, Gearbox, RH |
| 42 | 174698 | Seal, Oil |
| 43 | 174701 | Bushing, Flange, 1" |
| 44 | 178879 | Key, Square 1/4 x 1/4 x 7/8 |
| 45 | 174659 | Gear, Worm |
| 46 | 174657 | Shaft, Auger |
| 47 | 174687 | Housing, Gearbox, LH |
| 48 | 175321X479 | Impeller Assembly |
| 49 | 74780426 | Screw, Hex Head 1/4-20 x 1-5/8 |
| 50 | 175311 | Gasket, Gearbox |
| 51 | 7836M | Pin, Roll 3/16 x 1-1/8 |

NOTE: All component dimensions given in U.S. inches
1 inch = 25.4 mm

REPAIR PARTS

SNOW THROWER - MODEL NUMBER PP524A

CONTROL PANEL / DISCHARGE CHUTE

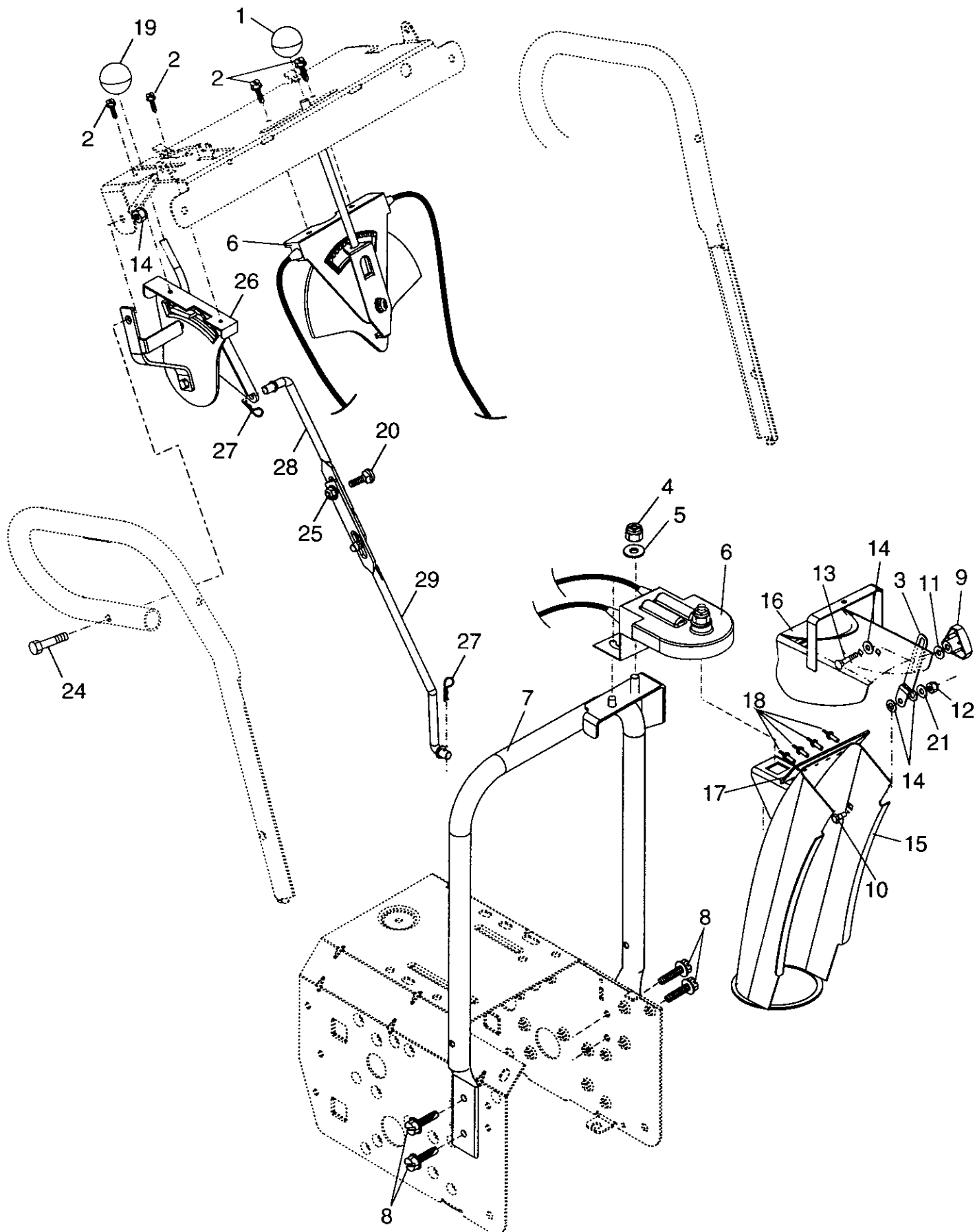

REPAIR PARTS**SNOW THROWER - MODEL NUMBER PP524A****CONTROL PANEL / DISCHARGE CHUTE**

| KEY NO. | PART NO. | DESCRIPTION |
|----------------|-----------------|---------------------------------|
| 1 | 183334 | Knob, Lever |
| 2 | 17501010 | Screw #10-24 x 5/8 |
| 3 | 179096X479 | Strap, Slotted |
| 4 | 73800600 | Nut, Lock 3/8-16 |
| 5 | 19131316 | Washer, Flat 3/8 |
| 6 | 178659 | Control Assembly, Chute Rotater |
| 7 | 178638X479 | Support, Pivot |
| 8 | 150078 | Screw, Hex Head 5/16-18 x 3/4 |
| 9 | 180453 | Knob, Deflector |
| 10 | 185600 | Bolt, Shoulder |
| 11 | 155415 | Washer, Flat |
| 12 | 73800400 | Nut, Lock 1/4-20 |
| 13 | 72270505 | Bolt, Carriage 5/16-18 x 5/8 |
| 14 | 179246 | Washer, Nylon |
| 15 | 178628X428 | Chute Assembly |
| 16 | 178633X428 | Deflector Assembly |
| 17 | 179145 | Seal, Deflector |
| 18 | 128415 | Rivet, Blind |
| 19 | 183333 | Knob, Speed Control Lever |
| 20 | 72270506 | Bolt, Carriage 5/16-18 x 3/4 |
| 21 | 53847 | Washer |
| 24 | 74780528 | Screw, Hex Head 5/16-18 x 1-3/4 |
| 25 | 155377 | Nut, Lock 5/16-18 |
| 26 | 179257 | Lever Assembly, Speed Control |
| 27 | 169675 | Retainer, Hairpin |
| 28 | 180445 | Rod, Upper, Speed Control |
| 29 | 180446 | Rod, Lower, Speed Control |

NOTE: All component dimensions given in U.S. inches
1 inch = 25.4 mm

**REPAIR PARTS
HANDLES**

SNOW THROWER - MODEL NUMBER PP524A

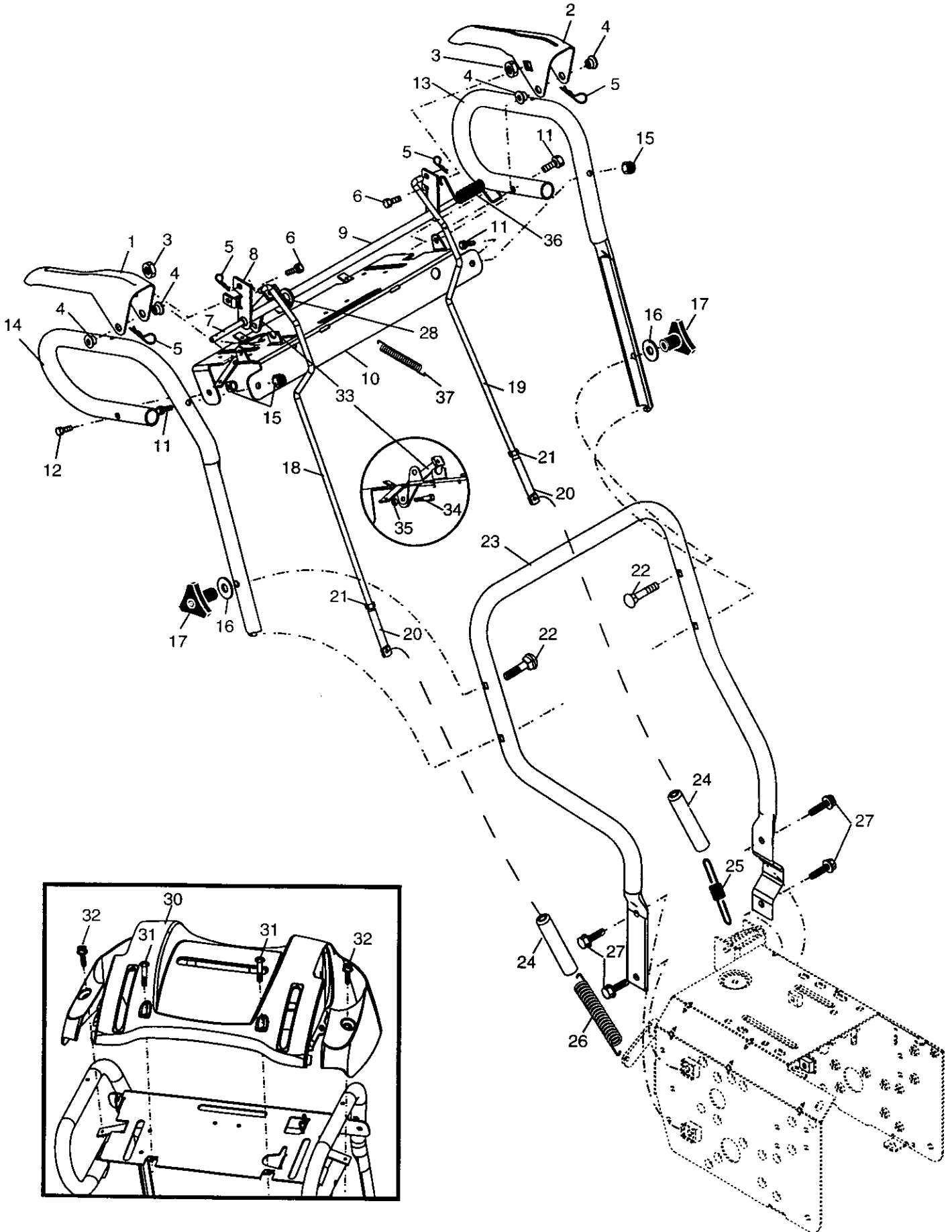

**REPAIR PARTS
HANDLES**

SNOW THROWER - MODEL NUMBER PP524A

| KEY NO. | PART NO. | DESCRIPTION |
|---------|------------|-----------------------------------------|
| 1 | 178875X479 | Lever, Auger Control, RH |
| 2 | 178648X479 | Lever, Traction Drive Control, LH |
| 3 | 179439 | Nut, Cage 1/4-20 |
| 4 | 178888 | Bushing, Flange |
| 5 | 169675 | Retainer, Hairpin |
| 6 | 180402 | Screw, Hex Head 1/4-20 x 3/4 |
| 7 | 178652 | Rod, Interlock |
| 8 | 184003 | Tube Assembly, Interlock, RH |
| 9 | 178651 | Tube Assembly, Interlock, LH |
| 10 | 178645X479 | Panel, Control |
| 11 | 74780524 | Screw, Hex Head 5/16-18 x 1-1/2 |
| 12 | 74780528 | Screw, Hex Head 5/16-18 x 1-3/4 |
| 13 | 178646X479 | Handle Tube, LH |
| 14 | 178696X479 | Handle Tube, RH |
| 15 | 73800500 | Nut, Lock 5/16-18 |
| 16 | 19131316 | Washer, Flat 3/8 |
| 17 | 178899 | Knob, Handle |
| 18 | 184594 | Rod, Auger Control |
| 19 | 179098 | Rod, Traction Control |
| 20 | 180428 | End, Control Rod |
| 21 | 73350500 | Nut, Hex, Jam 5/16-18 |
| 22 | 72120618 | Bolt, Carriage 3/8-16 x 2-1/4 |
| 23 | 178643X479 | Handle Tube, Lower |
| 24 | 180447 | Sleeve, Spring |
| 25 | 180926 | Spring, Traction Drive |
| 26 | 178669 | Spring, Auger Control |
| 27 | 71210616 | Screw, Hex Head 3/8-16 x 1 |
| 28 | 180494 | Clip, Panel |
| 30 | 183346 | Console, Panel |
| 31 | 175262 | Screw, Hex Head, Tapping #10-24 x 1-1/4 |
| 32 | 184471 | Screw, Hex Head, Tapping #10-24 x 1/2 |
| 33 | 175339X008 | Latch, Interlock |
| 34 | 183518 | Bolt, Shoulder |
| 35 | 68038 | Nut, Lock 1/4-20 |
| 36 | 178831 | Spring, Torsion |
| 37 | 178658 | Spring, Interlock |

NOTE: All component dimensions given in U.S. inches
1 inch = 25.4 mm

**REPAIR PARTS
DRIVE**

SNOW THROWER - MODEL NUMBER PP524A

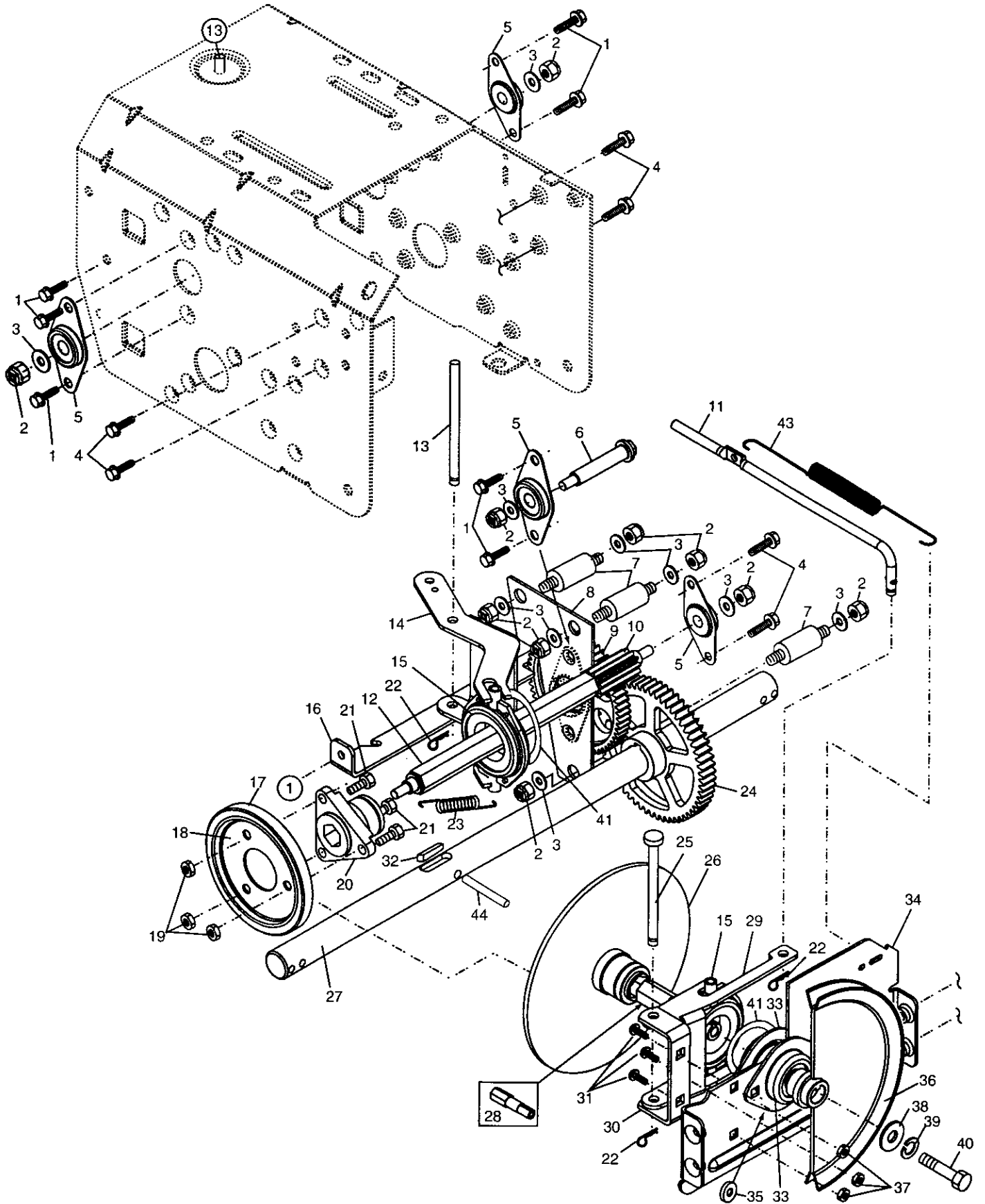

REPAIR PARTS DRIVE

SNOW THROWER - MODEL NUMBER PP524A

| KEY NO. | PART NO. | DESCRIPTION |
|---------|------------|-------------------------------|
| 1 | 146315 | Screw, Hex Head 5/16-18 x 5/8 |
| 2 | 73800500 | Nut, Lock 5/16-18 |
| 3 | 155415 | Washer, Flat |
| 4 | 17490508 | Screw, Hex Head 5/16-18 x 1/2 |
| 5 | 180017 | Bearing, Flange |
| 6 | 180134 | Shaft, Auxiliary |
| 7 | 179270 | Spacer, Plate |
| 8 | 179269X479 | Plate, Auxiliary |
| 9 | 180082 | Gear, Intermediate (12/58) |
| 10 | 180065 | Gear, Pinion |
| 11 | 187714 | Rod, Clutch |
| 12 | 180066 | Shaft, Long, Hex |
| 13 | 178807 | Pin, Pivot |
| 14 | 178619X479 | Lever, Shifter / Wheel |
| 15 | 175344 | Trunnion Bearing Assembly |
| 16 | 186951X479 | Bracket, Pivot, Shift |
| 17 | 179831 | Ring, Rubber Wheel |
| 18 | 178616X479 | Plate, Rubber Wheel |
| 19 | 73930500 | Nut, Lock 5/16-18 |
| 20 | 178613 | Hub, Rubber Wheel |
| 21 | 74760514 | Screw, Hex Head 5/16-18 x 7/8 |
| 22 | 85179 | Retainer, Hairpin |
| 23 | 180135 | Spring, Bias |
| 24 | 180081 | Gear, Axle (58 Teeth) |
| 25 | 178695 | Pin, Pivot Lever |
| 26 | 175341 | Plate Assembly, Drive |
| 27 | 179352 | Shaft, Axle |
| 28 | 175340 | Shaft, Short Hex |
| 29 | 175350X479 | Lever, Shifter Plate |
| 30 | 175349X479 | Bracket, Shifter Support |
| 31 | 72270505 | Bolt, Carriage 5/16-18 x 5/8 |
| 32 | 178879 | Key, Square 1/4 x 1/4 x 7/8 |
| 33 | 175323 | Bearing, Flange |
| 34 | 175338X479 | Plate, Drive Mounting |
| 35 | 182504 | Spacer, Bearing |
| 36 | 175348 | Pulley, Traction Drive |
| 37 | 155377 | Nut, Lock 5/16-18 |
| 38 | 19111507 | Washer, Flat |
| 39 | 10040500 | Washer, Lock 5/16 |
| 40 | 74950512 | Screw, Hex Head 5/16-18 x 3/4 |
| 41 | 12000012 | Ring, Retaining |
| 43 | 179095 | Spring, Return |
| 44 | 9465M | Pin, Roll |

NOTE: All component dimensions given in U.S. inches
1 inch = 25.4 mm

REPAIR PARTS

SNOW THROWER - MODEL NUMBER PP524A

CHASSIS / ENGINE / PULLEYS

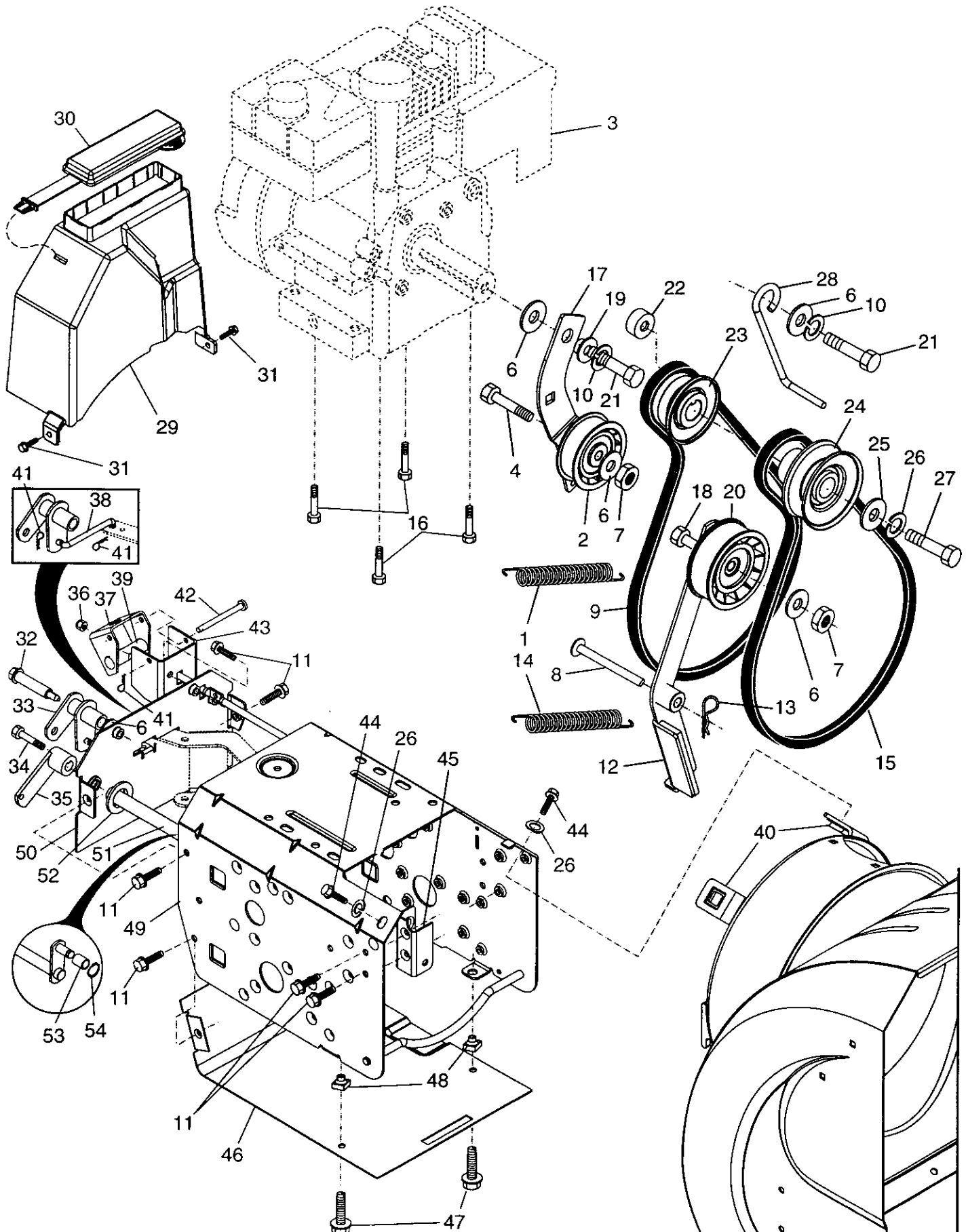

REPAIR PARTS**SNOW THROWER - MODEL NUMBER PP524A****CHASSIS / ENGINE / PULLEYS**

| KEY NO. | PART NO. | DESCRIPTION |
|---------|------------|---------------------------------------------------------------------------------|
| 1 | 181044 | Spring, Traction Idler |
| 2 | 180522 | Pulley, Idler (2-1/4) |
| 3 | - - - | Engine, Tecumseh, Model Number HSSK55 (Order parts from Engine manufacturer) |
| 4 | 74780520 | Screw, Hex Head 5/16-18 x 1-1/4 |
| 6 | 59289 | Washer, Flat |
| 7 | 73930500 | Nut, Jam, Lock 5/16-18 |
| 8 | 175330 | Pin, Idler Pivot |
| 9 | 179092 | V-Belt, Traction Drive |
| 10 | 10040500 | Washer, Lock 5/16 |
| 11 | 17490508 | Screw, Hex Head 5/16-18 x 3/4 |
| 12 | 179259 | Impeller Idler Arm Assembly |
| 13 | 85179 | Retainer, Hairpin |
| 14 | 178828 | Spring, Brake |
| 15 | 183533 | V-Belt, Impeller Drive |
| 16 | 150406 | Screw, Hex Head 3/8-16 x 1-1/4 |
| 17 | 179354 | Arm, Idler |
| 18 | 74780524 | Screw, Hex Head 5/16-18 x 1-1/2 |
| 19 | 175331 | Bushing, Idler Pivot |
| 20 | 180523 | Pulley, Idler (2-3/4) |
| 21 | 74610516 | Screw, Hex Head 5/16-24 x 1 |
| 22 | 179371 | Spacer, Engine Pulley |
| 23 | 180478 | Pulley, Engine, Traction Drive |
| 24 | 179157 | Pulley, Engine, Impeller Drive |
| 25 | 62735 | Washer, Flat 3/8 |
| 26 | 850263 | Washer, Lock 3/8 |
| 27 | 851084 | Screw, Hex Head 3/8-24 x 1-3/8 |
| 28 | 155452 | Guide, Belt |
| 29 | 180465 | Cover, Belt |
| 30 | 178830 | Cover, Toolbox |
| 31 | 17490408 | Screw, Hex Head 1/4-20 x 1/2 |
| 32 | 179256 | Bolt, Shoulder 5/16-18 |
| 33 | 187853 | Bellcrank Shifter |
| 34 | 180401 | Screw, Hex Head 1/4-28 x 3/4 |
| 35 | 179240 | Arm, Auger Control |
| 36 | 73800500 | Nut, Lock 5/16-18 |
| 37 | 178833X479 | Bellcrank Assembly |
| 38 | 187101 | Link, Speed Control |
| 39 | 179064 | Trunnion, Clutch |
| 40 | 178890 | Nut, Cage 3/8-16 |
| 41 | 700279 | Hairpin, Cotter 3/32 x 1/2 |
| 42 | 179065 | Pin, Bellcrank |
| 43 | 179063X479 | Bracket, Bellcrank |
| 44 | 74780624 | Screw, Hex Head 3/8-16 x 1-1/2 |
| 45 | 175324X479 | Pivot Bracket, Impeller Idler Arm |
| 46 | 178624X479 | Pan, Frame Bottom |
| 47 | 71020512 | Screw, Hex Head 5/16-18 x 3/4 |
| 48 | 181156 | Nut, Speed 5/16-18 |
| 49 | 183852X428 | Frame Assembly |
| 50 | 187715X428 | Plate, Frame End |
| 51 | 179068X008 | Shaft, Auger Control |
| 52 | 57079 | Washer, Hardened |
| 53 | 179062 | Roller |
| 54 | 12000010 | Ring, Retaining |

NOTE: All component dimensions given in U.S. inches. 1 inch = 25.4 mm

REPAIR PARTS
WHEELS / DECALS

SNOW THROWER - MODEL NUMBER PP524A

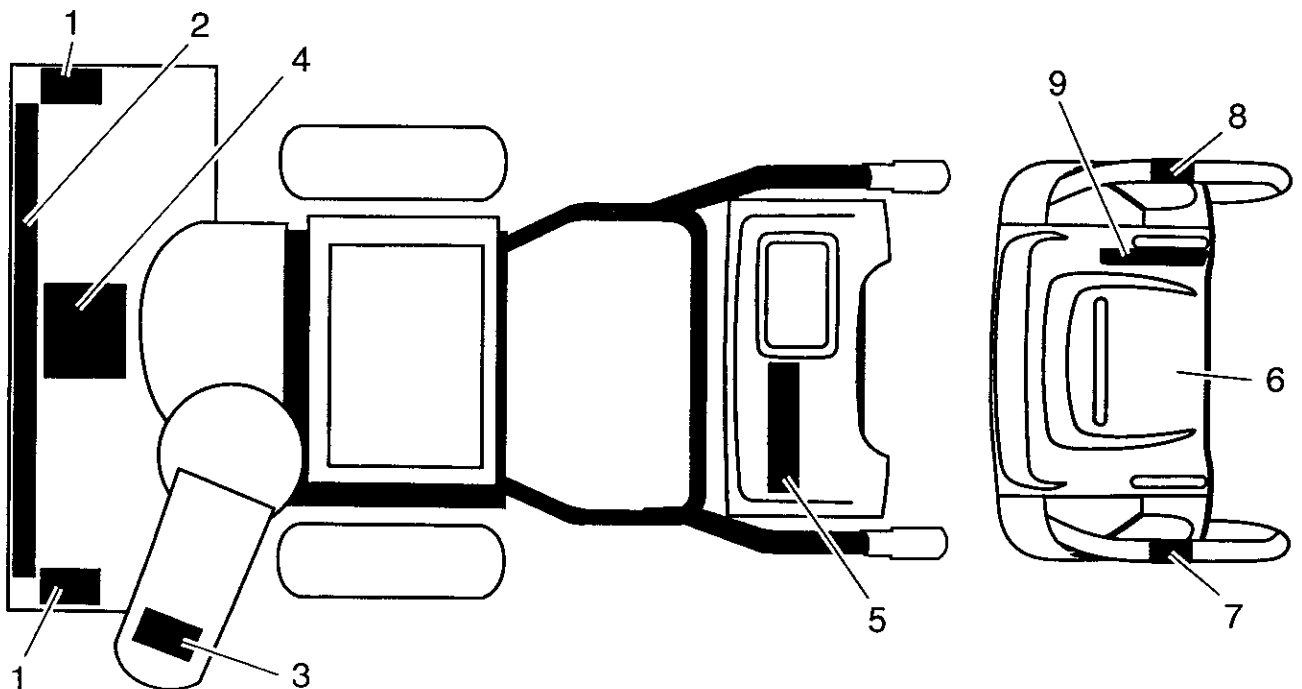
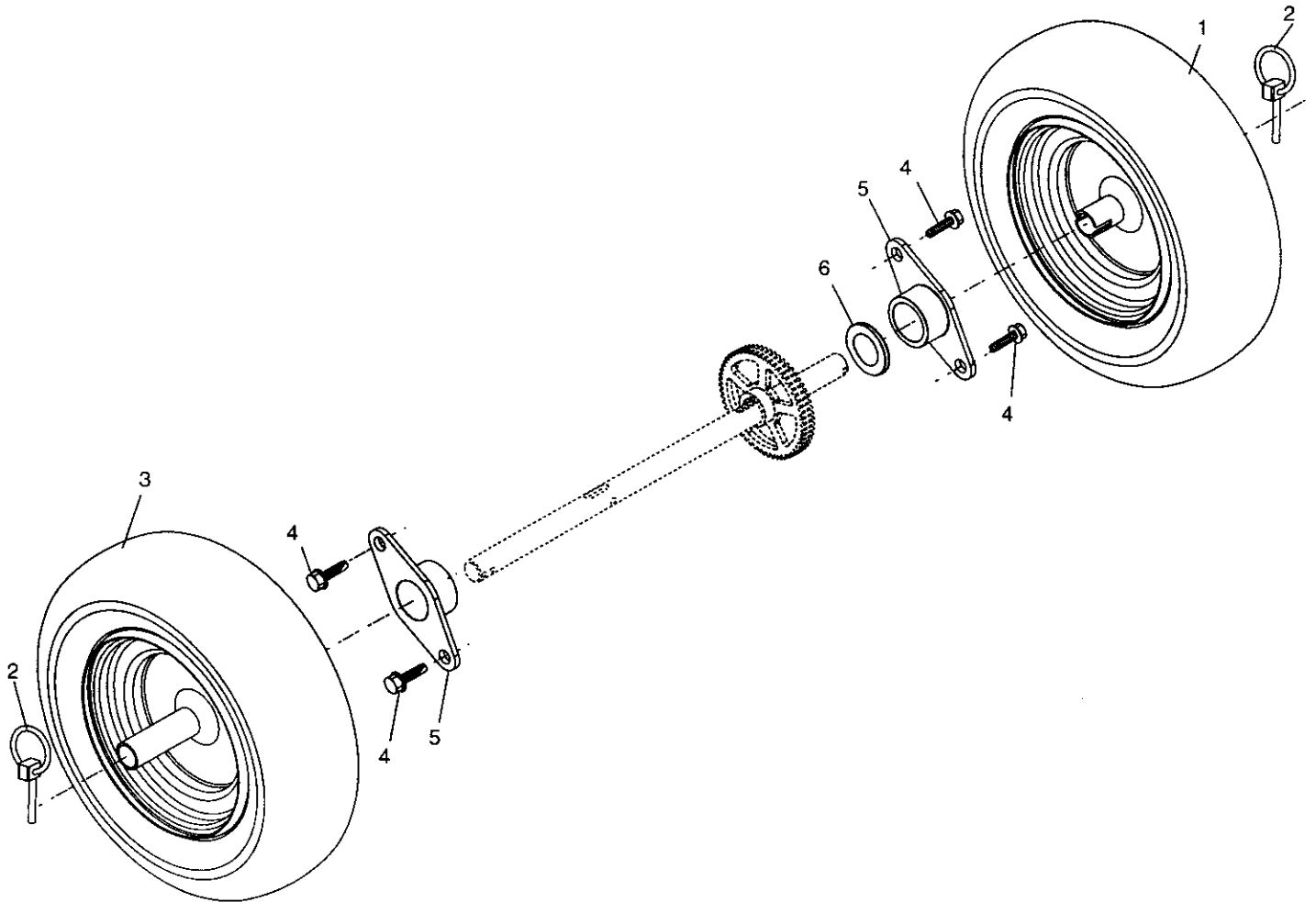

**REPAIR PARTS
WHEELS / DECALS**

SNOW THROWER - MODEL NUMBER PP524A

| KEY NO. | PART NO. | DESCRIPTION |
|----------------|-----------------|-------------------------------|
| 1 | 187873 | Wheel Assembly, 13", LH |
| 2 | 155443 | Pin, Klik 1/4 |
| 3 | 187875 | Wheel Assembly, 13", RH |
| 4 | 146315 | Screw, Hex Head 5/16-18 x 5/8 |
| 5 | 179830 | Bearing, Axle |
| 6 | 174697 | Washer, Thrust (1") |

NOTE: All component dimensions given in U.S. inches
1 inch = 25.4 mm

| KEY NO. | PART NO. | DESCRIPTION |
|----------------|-----------------|------------------------------------|
| 1 | 181037 | Decal, Danger |
| 2 | 187868 | Decal, Poulan Pro, 5HP/24" (large) |
| 3 | 181035 | Decal, Danger, Deflector |
| 4 | 181042 | Decal, Danger |
| 5 | 187893 | Decal, Poulan Pro, 5HP/24" (small) |
| 6 | 181033 | Decal, Instruction |
| 7 | 155798 | Decal, Traction Lever |
| 8 | 155800 | Decal, Auger Lever |
| 9 | 181039 | Decal, Speed Control |
| -- | 187877 | Owner's Manual, English |
| -- | 187878 | Owner's Manual, French |

NOTE: All component dimensions given in U.S. inches
1 inch = 25.4 mm

LIMITED WARRANTY

The Manufacturer warrants to the original consumer purchaser that this product as manufactured is free from defects in materials and workmanship. For a period of two (2) years from date of purchase by the original consumer purchaser, we will repair or replace, at our option, without charge for parts or labor incurred in replacing parts, any part which we find to be defective due to materials or workmanship. This Warranty is subject to the following limitations and exclusions.

1. This warranty does not apply to the engine or components parts thereof. Please refer to the applicable manufacturer's warranty on these items.
2. Transportation charges for the movement of any power equipment unit or attachment are the responsibility of the purchaser. Transportation charges for any parts submitted for replacement under this warranty must be paid by the purchaser unless such return is requested by Electrolux Home Products.
3. The Warranty period for any products used for rental or commercial purposes is limited to 90 days from the date of original purchase.
4. This Warranty applies only to products which have been properly assembled, adjusted, operated, and maintained in accordance with the instructions furnished. This Warranty does not apply to any product which has been subjected to alteration, misuse, abuse, improper assembly or installation, delivery damage, or to normal wear of the product.
5. Exclusions: Excluded from this Warranty are belts, shear pins, normal wear, normal adjustments, standard hardware and normal maintenance.
6. In the event you have a claim under this Warranty, you must return the product to an authorized service dealer.

Should you have any unanswered questions concerning this Warranty, please contact:

In Canada contact:

Electrolux Canada Corp.
7075 Ordan Drive
Mississauga, Ontario
L5T 1K6

Electrolux Home Products, Inc.

Outdoor Products Customer Service Dept.
250 Bobby Jones Expressway
Augusta, GA 30909 USA

giving the complete mfg. ID#, serial number and date of purchase of your product and the name and address of the authorized dealer from whom it was purchased.

THIS WARRANTY DOES NOT APPLY TO INCIDENTAL OR CONSEQUENTIAL DAMAGES AND ANY IMPLIED WARRANTIES ARE LIMITED TO THE SAME TIME PERIODS STATED HEREIN FOR OUR EXPRESSED WARRANTIES. Some areas do not allow the limitation of consequential damages or limitations of how long an implied Warranty may last, so the above limitations or exclusions may not apply to you. This Warranty gives you specific legal rights, and you may have other rights which vary from locale to locale.

This is a limited Warranty within the meaning of that term as defined in the Magnuson-Moss Act of 1975.

Poulan PRO