

IMPORTANT MANUAL

Do Not Throw Away

Poulan PRO

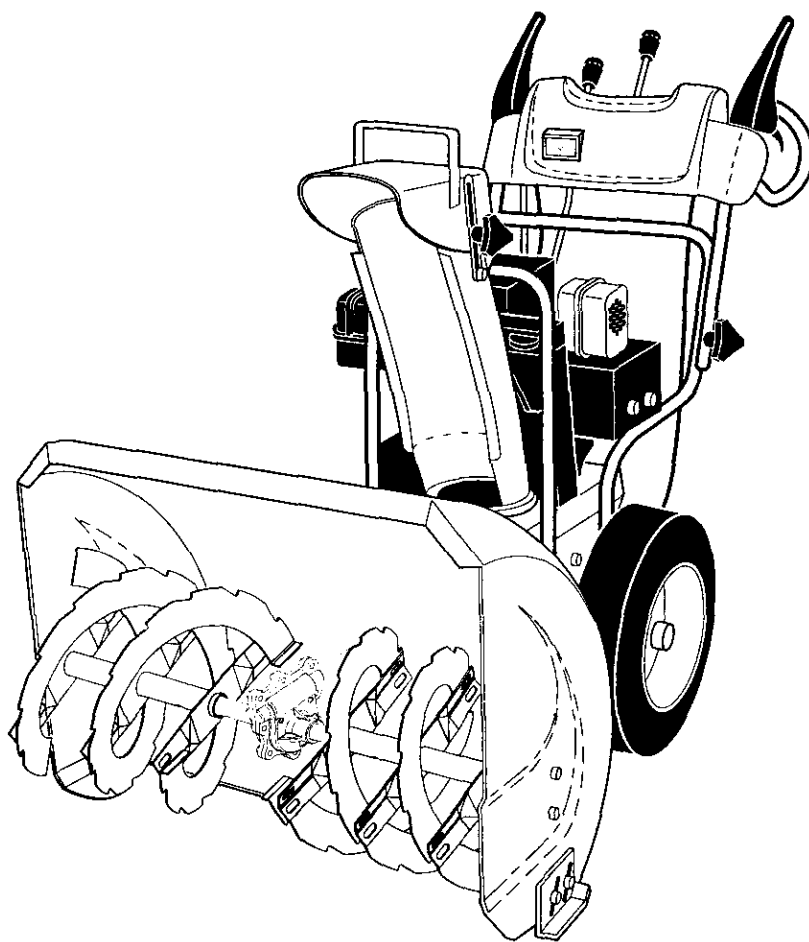

OWNER'S MANUAL

MODEL NUMBER:
PP8527ESA
SNOW THROWER

⚠ WARNING:
Read the Owner's Manual and follow all Warnings and Safety Instructions. Failure to do so can result in serious injury.

Always Wear Eye Protection During Operation

187887 07.29.03 BY
Printed in U.S.A.



SAFETY RULES





Safe Operation Practices for Snow Throwers

IMPORTANT: This machine is capable of amputating hands and feet and throwing objects. Failure to observe the following safety instructions could result in serious injury or death.

 **Look for this symbol to point out important safety precautions. It means CAUTION!!! BECOME ALERT!!! YOUR SAFETY IS INVOLVED.**

 **WARNING: Always disconnect spark plug wire and place it where it cannot contact plug in order to prevent accidental starting when setting up, transporting, adjusting or making repairs.**

 **WARNING: This snow thrower is for use on sidewalks, driveways and other ground level surfaces. Caution should be exercised while using on sloping surfaces. Do not use snow thrower on surfaces above ground level such as roofs of residences, garages, porches or other such structures or buildings.**

 **WARNING: Snow throwers have exposed rotating parts, which can cause severe injury from contact, or from material thrown from the discharge chute. Keep the area of operation clear of all persons, small children and pets at all times including startup.**

 **CAUTION: Muffler and other engine parts become extremely hot during operation and remain hot after engine has stopped. To avoid severe burns on contact, stay away from these areas.**

 **WARNING: Engine exhaust, some of its constituents, and certain vehicle components contain or emit chemicals known to the State of California to cause cancer and birth defects or other reproductive harm.**

TRAINING

- Read the operating and service instruction manual carefully. Be thoroughly familiar with the controls and the proper use of the equipment. Know how to stop the unit and disengage the controls quickly.
- Never allow children to operate the equipment. Never allow adults to operate the equipment without proper instruction.
- Keep the area of operation clear of all persons, particularly small children and pets.
- Exercise caution to avoid slipping or falling especially when operating in reverse.

PREPARATION

- Remove foreign objects. Thoroughly inspect the area where the equipment is to be used and remove all doormats, sleds, boards, wires, rocks & landscaping.
- Disengage all clutches before starting engine (motor).

- Do not operate the equipment without wearing adequate winter outer garments. Avoid loose, dangling clothing, such as scarves, which can get caught in rotating parts. Wear footwear that will improve footing on slippery surfaces.
- Handle fuel with care; it is highly flammable.
 - Never smoke while refueling.
 - Use an approved fuel container.
 - Never remove fuel tank cap or add fuel to a running engine (motor) or hot engine (motor).
 - Fill fuel tank outdoors with extreme care. Never fill fuel tank indoors.
 - Replace fuel cap securely and wipe up spilled fuel.
 - Never store fuel or snow thrower with fuel in the tank inside of a building where fumes may reach an open flame or spark.
 - Check fuel supply before each use, allowing space for expansion as the heat of the engine (motor) and/or sun cause fuel to expand.

STATIC ELECTRICITY HAZARD -

- Never fill containers inside a vehicle or on a truck or trailer bed with a plastic liner. Always place containers on the ground, away from your vehicle before filling.
- When practical, remove gas-powered equipment from the truck or trailer and refuel it on the ground. If this is not possible, then refuel such equipment on a trailer with a portable container, rather than from a gasoline dispenser nozzle.
- Keep the nozzle in contact with the rim of the fuel tank opening at all times, until refueling is complete. Do not use a nozzle lock-open device.
- If fuel is spilled on clothing, change clothing immediately.
- For all units with electric starting motors use electric starting extension cords certified CSA/UL. Use only with a receptacle that has been installed in accordance with local inspection authorities.
- If snow thrower must be operated over gravel surface, use extra caution and be sure skid plates are adjusted to lowest (highest scraper clearance) position.
- Never attempt to make any adjustments while the engine (motor) is running (except when specifically recommended by manufacturer).
- Let engine (motor) and snow thrower adjust to outdoor temperatures before starting to clear snow.
- Always wear safety glasses or eye shields during operation or while performing an adjustment or repair to protect eyes from foreign objects that may be thrown from the snow thrower.

OPERATION

- Do not operate this machine if you are under the influence of alcohol or taking drugs or other medication which can cause drowsiness or affect your ability to operate this machine.
- Do not use this machine if you are mentally or physically unable to operate this machine safely.

- Do not put hands or feet near or under rotating parts. Keep clear of the discharge opening and front auger area at all times.
- Exercise extreme caution when operating on or crossing gravel drives, walks or roads. Stay alert for hidden hazards or traffic.
- After striking a foreign object, stop the engine (motor), remove wire from the spark plug, thoroughly inspect snow thrower for any damage, and repair the damage before restarting and operating the snow thrower.
- If the unit should start to vibrate abnormally, stop the engine (motor) and check immediately for the cause. Vibration is generally a warning of trouble.
- Stop the engine (motor) whenever you leave the operating position, before unclogging the auger/impeller housing or discharge chute and when making any repairs, adjustments, or inspections.
- When cleaning, repairing, or inspecting, make certain all controls are disengaged and the auger/impeller and all moving parts have stopped. Disconnect the spark plug wire and keep the wire away from the spark plug to prevent accidental starting.
- Take all possible precautions when leaving the snow thrower unattended. Disengage the auger/impeller, stop engine (motor), and remove key.
- Do not run the engine (motor) indoors, except when starting the engine (motor) and for transporting the snow thrower in or out of the building. Open the outside doors.
- Do not overload the machine capacity by attempting to clear snow at too fast a rate.
- Never operate the machine at high transport speeds on slippery surfaces. Look behind and use care when backing up.
- Never direct discharge at bystanders or allow anyone in front of the unit.
- Disengage power to the auger/impeller when snow thrower is transported or not in use.
- Use only attachments and accessories approved by the manufacturer of the snow thrower (such as wheel weights, counterweights, cabs, tire chains, electric start kits, etc.).
- Never operate the snow thrower without good visibility or light. Always be sure of your footing and keep a firm hold on the handles. Walk; never run.
- Do not overreach. Keep proper footing and balance at all times.
- This snow thrower is for use on sidewalks, driveways and other ground level surfaces.
- Do not use the snow thrower on surfaces above ground level such as roofs of residences, garages, porches or other such structures or buildings.



WARNING: Exhaust fumes are dangerous (containing CARBON MONOXIDE, an ODORLESS and DEADLY GAS).

- Do not clear snow across the face of slopes. Exercise extreme caution when changing direction on slopes. Do not attempt to clear steep slopes.
- Never operate the snow thrower without proper guards, plates or other safety protective devices in place.
- Never operate the snow thrower near glass enclosures, automobiles, window wells, drop-offs, and the like without proper adjustment of the snow discharge angle. Keep children and pets away.

MAINTENANCE AND STORAGE

- Check shear bolts and other bolts at frequent intervals for proper tightness to be sure the equipment is in safe working condition.
- Never store the snow thrower with fuel in the tank inside a building where ignition sources are present such as hot water and space heaters, clothes dryers, and the like. Allow the engine (motor) to cool before storing in any enclosure.
- Always refer to operator's guide instructions for important details if the snow thrower is to be stored for an extended period.
- Maintain or replace safety and instruction labels, as necessary.
- Run the snow thrower, with auger engaged, a few minutes after throwing snow to clear the machine and prevent freeze-up of the auger/impeller.

CONGRATULATIONS on your purchase of a new snow thrower. It has been designed, engineered and manufactured to give best possible dependability and performance.

Should you experience any problem you cannot easily remedy, please contact your nearest authorized service center. We have competent, well-trained technicians and the proper tools to service or repair this unit.

Please read and retain this manual. The instructions will enable you to assemble and maintain your snow thrower properly. Always observe the "SAFETY RULES".

SERIAL NUMBER: _____

DATE OF PURCHASE: _____

THE MODEL AND SERIAL NUMBERS WILL BE FOUND ON A DECAL ATTACHED TO THE REAR OF THE SNOW THROWER HOUSING.

YOU SHOULD RECORD BOTH SERIAL NUMBER AND DATE OF PURCHASE AND KEEP IN A SAFE PLACE FOR FUTURE REFERENCE.

PRODUCT SPECIFICATIONS

Gasoline Capacity and Type:	4.0 Quarts Unleaded Regular only
Oil Type (API-SF-SJ):	SAE 30 (above 40°F) SAE 5W-30 or 10W-30 (0° to +40°F) SAE 0W-30 (below 0°F)
Oil Capacity:	26 Ounces
Spark Plug:	Champion RN4C (Gap: .030")

CUSTOMER RESPONSIBILITIES

- Read and observe the safety rules.
- Follow a regular schedule in maintaining, caring for and using your snow thrower.
- Follow the instructions under "Maintenance" and "Storage" sections of this owner's manual.

SAFETY RULES 2-3
 PRODUCT SPECIFICATIONS 3
 CUSTOMER RESPONSIBILITIES 3
 WARRANTY 32
 ASSEMBLY / PRE-OPERATION 5-7
 OPERATION 8-13

MAINTENANCE 14-15
 MAINTENANCE SCHEDULE 14
 SERVICE AND ADJUSTMENTS 16-18
 STORAGE 18
 TROUBLESHOOTING 19
 REPAIR PARTS 20-31

PARTS PACKED SEPARATELY IN CARTON

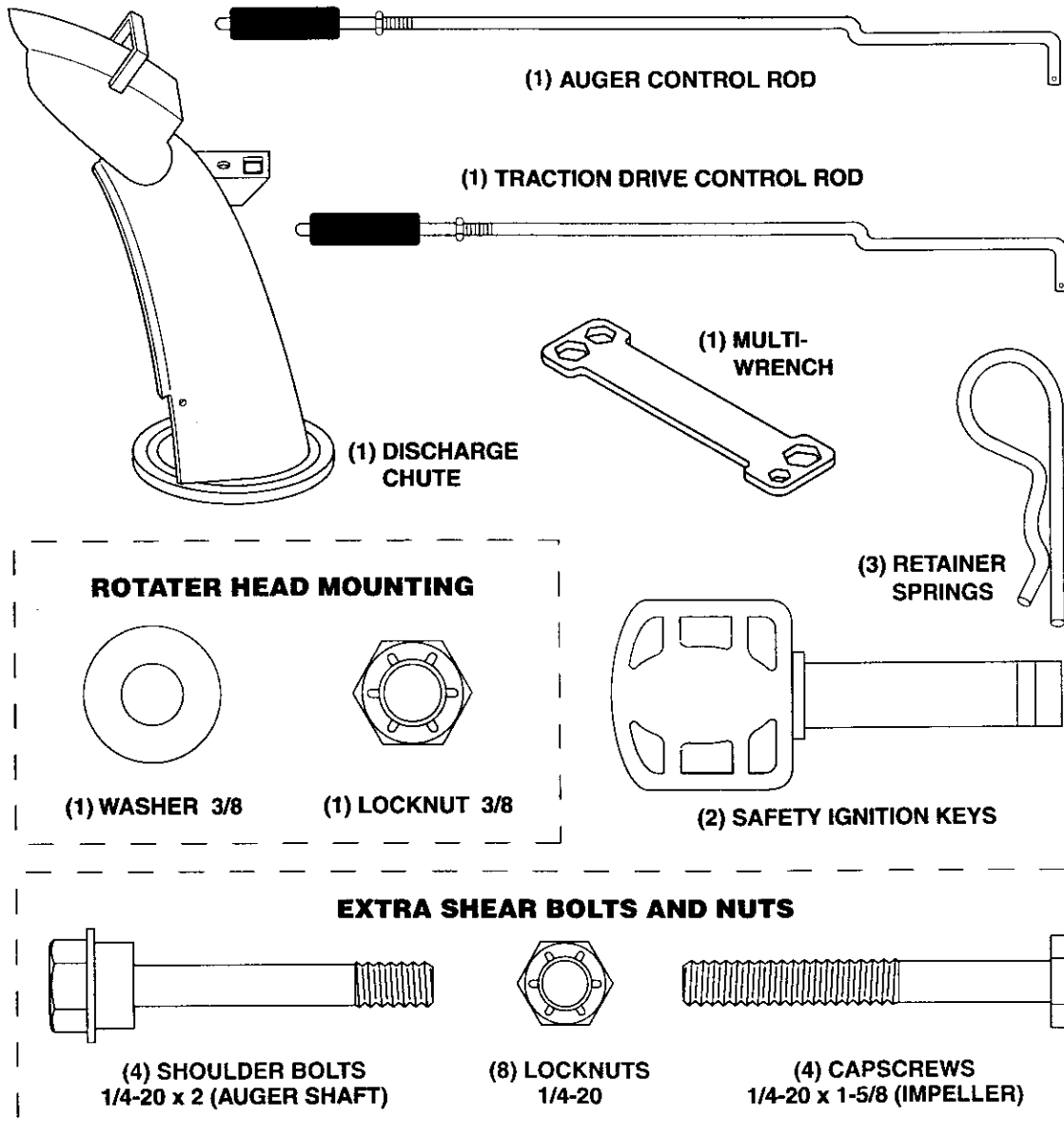

ASSEMBLY / PRE-OPERATION

Read these instructions and this manual in its entirety before you attempt to assemble or operate your new snow thrower.

Your new snow thrower has been assembled at the factory with the exception of those parts left unassembled for shipping purposes. All parts such as nuts, washers, bolts, etc., necessary to complete the assembly have been placed in the parts bag. To ensure safe and proper operation of your snow thrower, all parts and hardware you assemble must be tightened securely. Use the correct tools as necessary to ensure proper tightness.

REMOVE SNOW THROWER FROM CARTON

1. Remove all accessible loose parts and parts boxes from carton.
2. Cut down all four corners of carton and lay panels flat.
3. Remove all packing materials except plastic tie holding speed control rod to lower handle.
4. Remove snow thrower from carton and check carton thoroughly for additional loose parts.

HOW TO SET UP YOUR SNOW THROWER

TOOL BOX (See Fig. 8)

A toolbox is provided on your snow thrower. The toolbox is located on top of the belt cover. Store the extra shear bolts, nuts and multi-wrench provided in parts bag in the toolbox.

NOTE: The multi-wrench may be used for assembly of the chute rotator head to snow thrower and making adjustments to the skid plates.

UNFOLD UPPER HANDLE

1. Raise upper handle to the operating position and tighten handle knobs securely.

INSTALL SPEED CONTROL ROD (See Figs. 1 and 2)

1. Remove plastic tie securing rod to lower handle.
2. Insert rod into speed control bracket and secure with retainer spring.

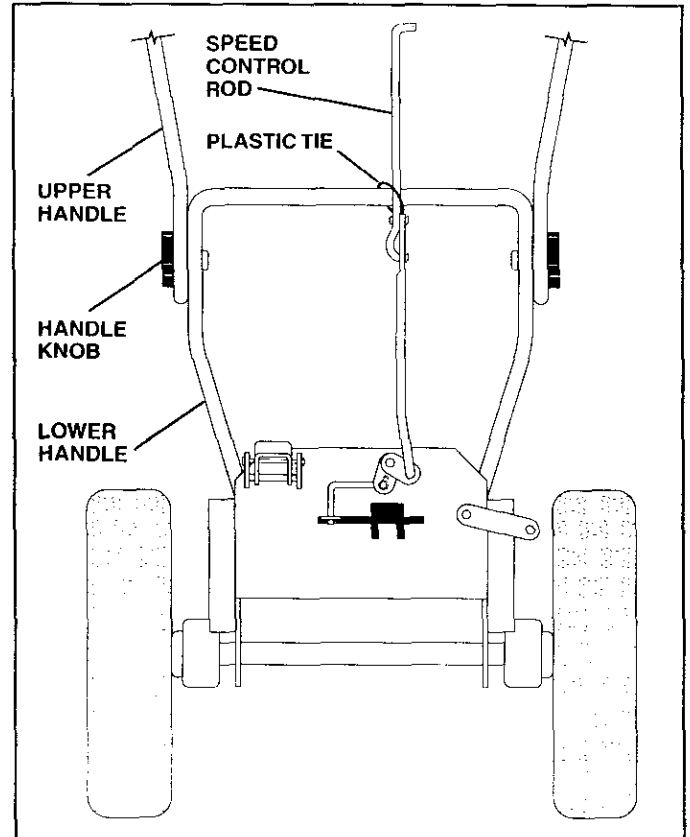

FIG. 1

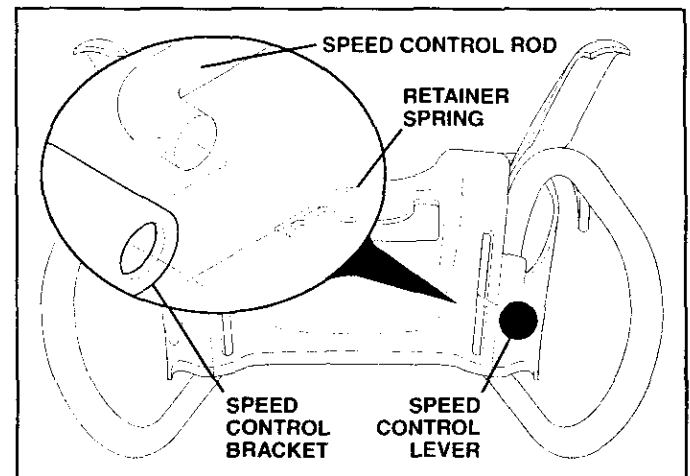

FIG. 2

ASSEMBLY / PRE-OPERATION

INSTALL TRACTION DRIVE CONTROL ROD (See Figs. 3 and 4)

The traction drive control rod has the long loop on the end of the spring as shown.

1. Slide rubber sleeve up rod and hook end of spring into pivot bracket with loop opening down as shown.
2. With top end of rod positioned under left side of control panel, push rod down and insert top end of rod into hole in drive control bracket. Secure with retainer spring.

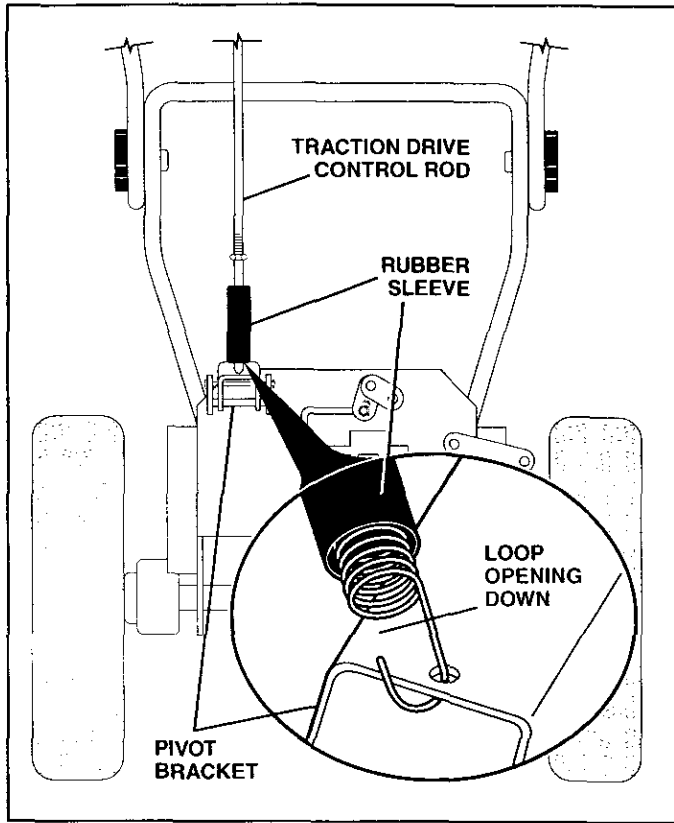

FIG. 3

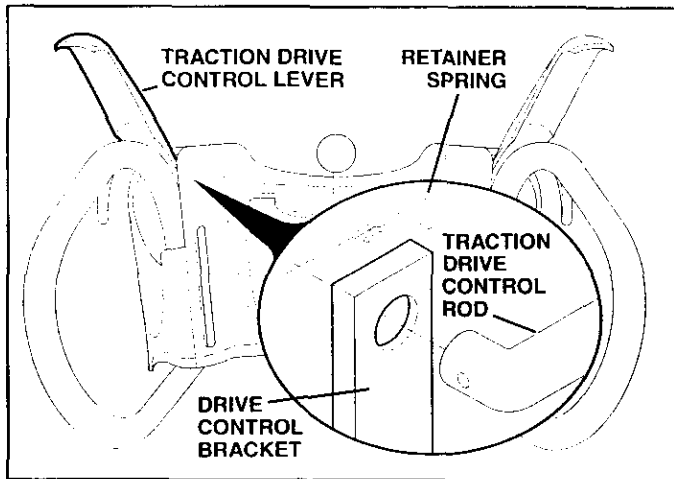

FIG. 4

INSTALL AUGER CONTROL ROD (See Figs. 5 and 6)

The auger control rod has the short loop on the end of the spring as shown.

1. Slide rubber sleeve up rod and hook end of spring into control arm with loop opening up as shown.
2. With top end of rod positioned under right side of control panel, push rod down and insert end of rod into hole in auger control bracket. Secure with retainer spring.

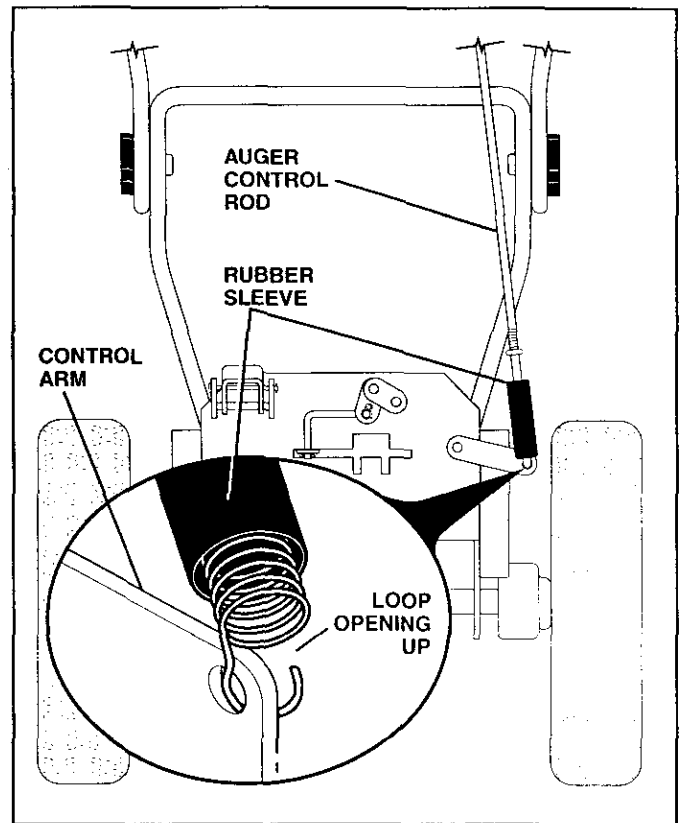

FIG. 5

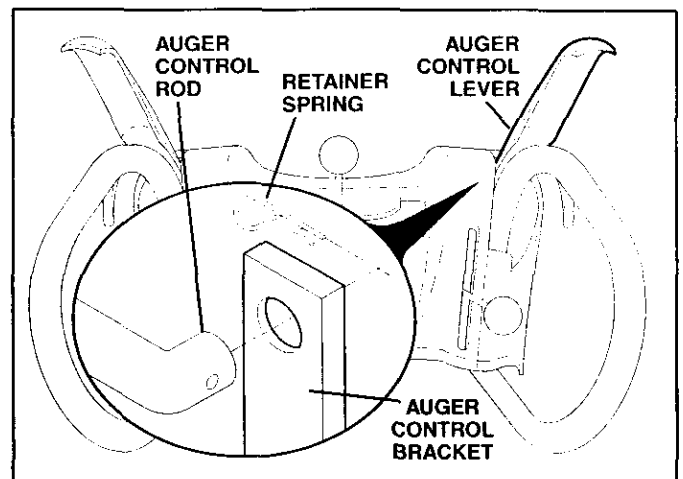

FIG. 6

ASSEMBLY / PRE-OPERATION

INSTALL DISCHARGE CHUTE/CHUTE ROTATER HEAD (See Fig. 7)

NOTE: The multi-wrench provided in your parts bag may be used to install the chute rotater head.

1. Place discharge chute assembly on top of chute base with discharge opening toward front of snow thrower.
2. Position chute rotater head over chute bracket. If necessary, rotate chute assembly to align square and pin on underside of chute rotater head with holes in chute bracket.
3. With chute rotater head and chute bracket aligned, position chute rotater head on pin and threaded stud of mounting bracket.
4. Install 3/8 washer and locknut on threaded stud and tighten securely.

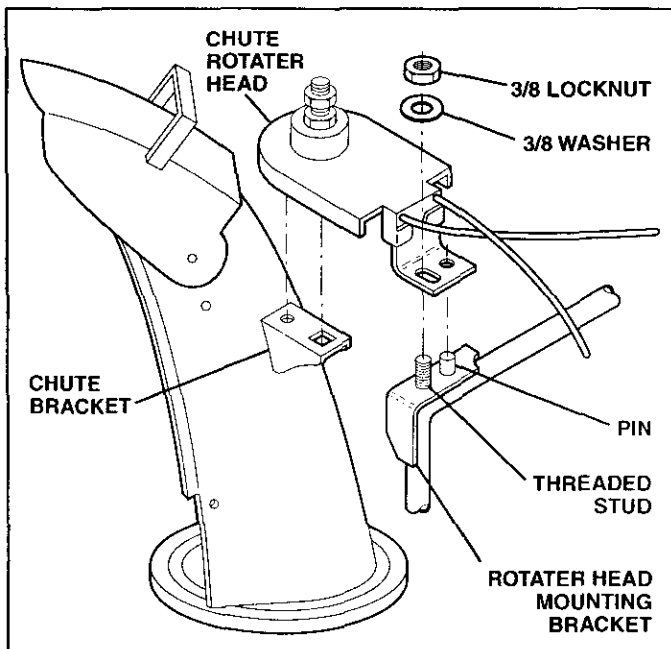

FIG. 7

CHECK TIRE PRESSURE

The tires on your snow thrower were overinflated at the factory for shipping purposes. Correct and equal tire pressure is important for best snow throwing performance.

- Reduce tire pressure to 14–17 PSI.

OPERATION

KNOW YOUR SNOW THROWER

READ THIS OWNER'S MANUAL AND ALL SAFETY RULES BEFORE OPERATING YOUR SNOW THROWER. Compare the illustrations with your snow thrower to familiarize yourself with the location of various controls and adjustments. Save this manual for future reference.

These symbols may appear on your snow thrower or in literature supplied with the product. Learn and understand their meaning.

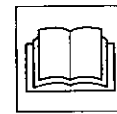

READ AND FOLLOW ALL SAFETY INFORMATION AND INSTRUCTIONS BEFORE USE OF THIS PRODUCT. KEEP THESE INSTRUCTIONS FOR FUTURE REFERENCE.

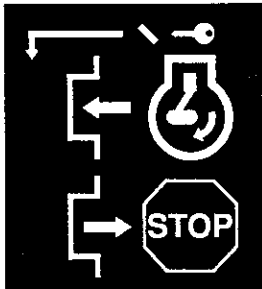

IGNITION KEY. INSERT TO START AND RUN, PULL OUT TO STOP.

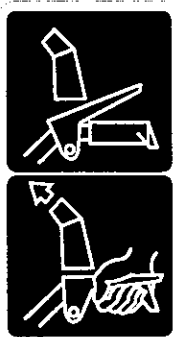

DISENGAGED



ENGAGED

SNOW DISCHARGE



TRACTION DRIVE CONTROL



OPERATION

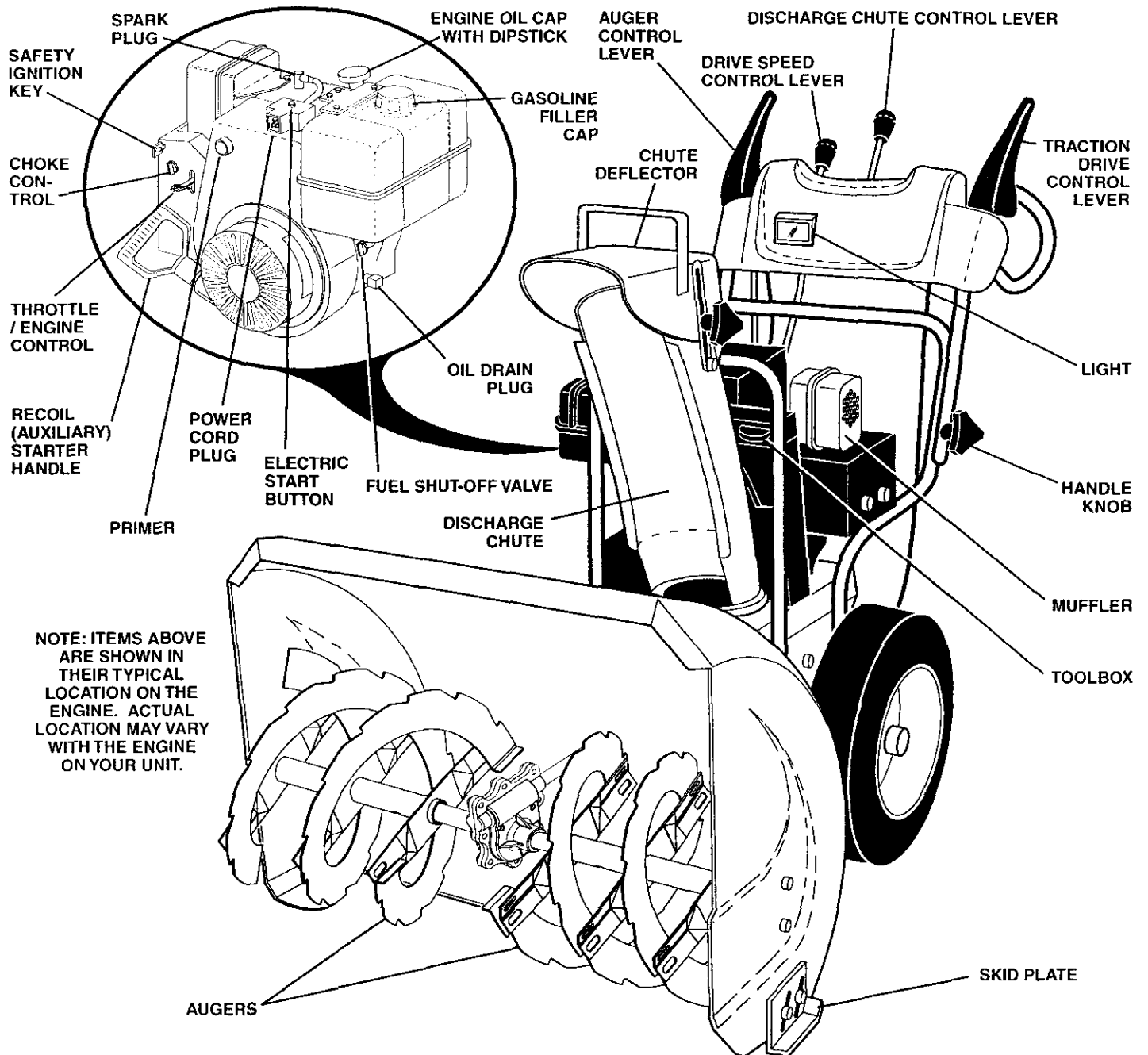

FIG. 8

MEETS A.N.S.I. SAFETY REQUIREMENTS

Our snow throwers conform to the standards of the American National Standards Institute.

Toolbox - used to store spare shear bolts, locknuts and wrench.

Safety ignition key - must be inserted for the engine to start and run. Remove when snow thrower is not in use.

Electric start button - used for starting the engine.

Recoil (auxiliary) starter handle - used for starting the engine.

Primer - pumps additional fuel from the carburetor to the cylinder for use when starting a cold engine.

Throttle/engine control - used to select either FAST or SLOW engine speed and to STOP the engine.

Choke control - used for starting a cold engine.

Drive speed control lever - used to select forward or reverse motion and speed of snow thrower.

Traction drive control lever - used to engage power-propelled forward or reverse motion of snow thrower.

Auger control lever - used to engage auger motion (throw snow).

Discharge chute control lever - used to change the direction the snow is thrown.

Skid plate - used to adjust height of scraper bar from the ground.

OPERATION



The operation of any snow thrower can result in foreign objects thrown into the eyes, which can result in severe eye damage. Always wear safety glasses or eye shields while operating your snow thrower or performing any adjustments or repairs. We recommend standard safety glasses or a wide vision safety mask worn over spectacles.

HOW TO USE YOUR SNOW THROWER

Know how to operate all controls before adding fuel or attempting to start the engine.

STOPPING

TRACTION DRIVE

- Release traction drive control lever to stop the forward or reverse movement of the snow thrower.

AUGER

- Release the auger control lever to stop throwing snow.

ENGINE

1. Move throttle control to "STOP" position.
2. Remove (do not turn) safety ignition key to prevent unauthorized use.

NOTE: Never use choke to stop engine.

TO USE FUEL SHUT-OFF VALVE (See Fig. 9)

The fuel shut-off valve is located beneath the fuel tank on the engine. Always operate the snow thrower with the fuel shut-off valve in the OPEN position.

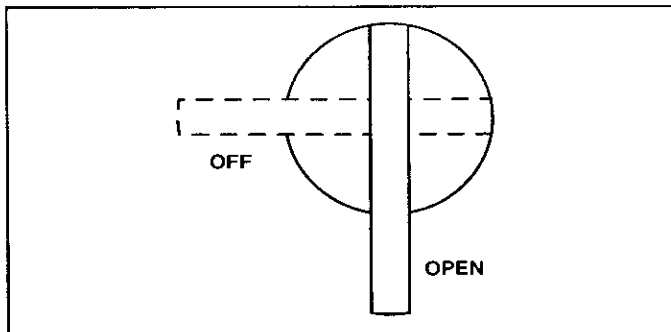

FIG. 9

TO USE THROTTLE CONTROL (See Fig. 10)

The throttle control is located on the engine. Always operate the snow thrower with the engine at full throttle. Full throttle offers the best snow thrower performance.

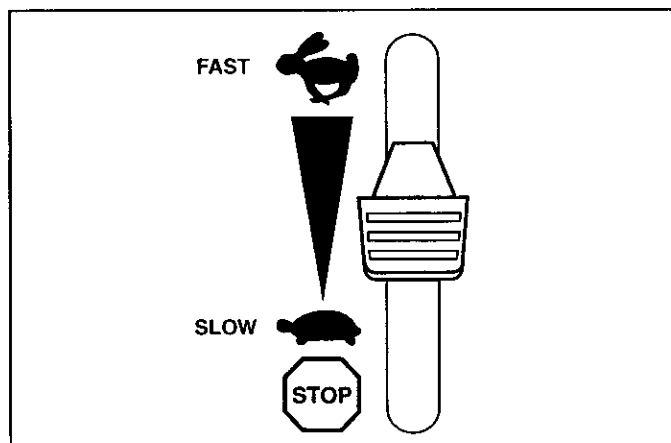

FIG. 10

TO USE CHOKE CONTROL (See Fig. 11)

The choke control is located on the engine. Use the choke control whenever you are starting a cold engine. Do not use to start a warm engine.

- To engage choke, turn knob clockwise. Slowly turn knob counterclockwise to disengage.

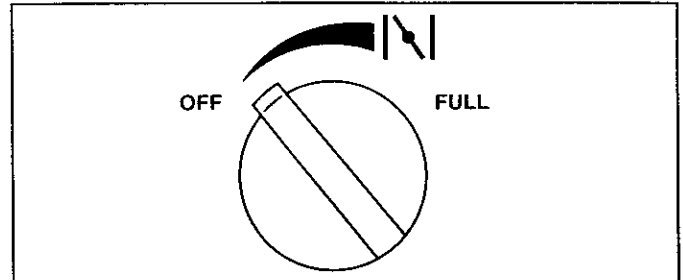

FIG. 11

TO CONTROL SNOW DISCHARGE (See Figs. 12 & 13)



WARNING: Snow throwers have exposed rotating parts, which can cause severe injury from contact, or from material thrown from the discharge chute. Keep the area of operation clear of all persons, small children and pets at all times including startup.



WARNING: If the discharge chute or auger become clogged, shut-off engine and wait for all moving parts to stop. Use a stick, NOT YOUR HANDS, to unclog the chute and/or auger.

The **DIRECTION** in which snow is to be thrown is controlled by the discharge chute control lever.

- To change the discharge chute position, press downward on discharge chute control lever and move lever left or right until chute is in desired position. Be sure lever springs back and locks into desired position.

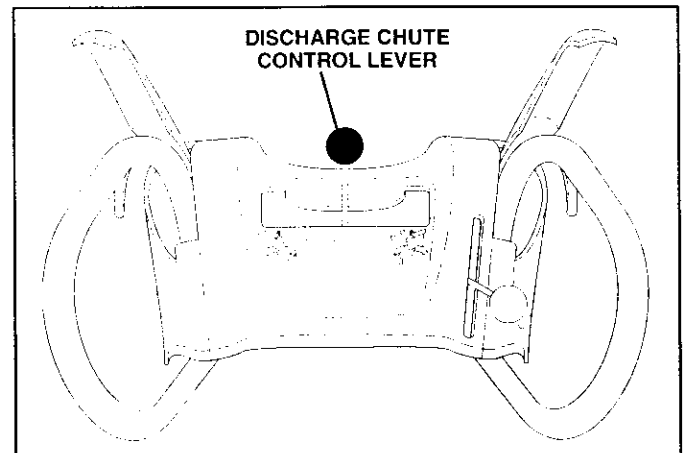

FIG. 12

The **DISTANCE** that snow is thrown is controlled by the position of the chute deflector. Set the deflector low to throw snow a short distance; set the deflector higher to throw snow farther.

- To change the deflector position, loosen knob, move deflector to desired position and tighten knob securely.

OPERATION

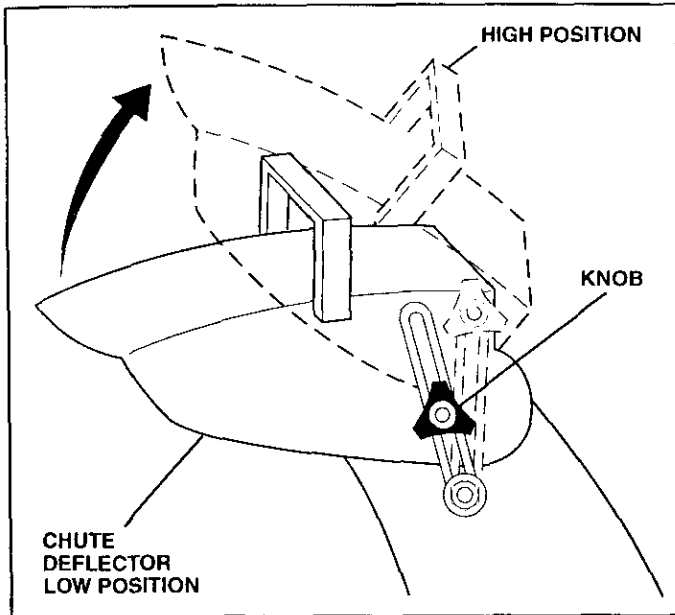

FIG. 13

TO THROW SNOW (See Fig. 14)

The auger rotation is controlled by the auger control lever located on the right side handle.

- Squeeze auger control lever to handle to engage the auger and throw snow.
- Release the auger control lever to stop throwing snow.

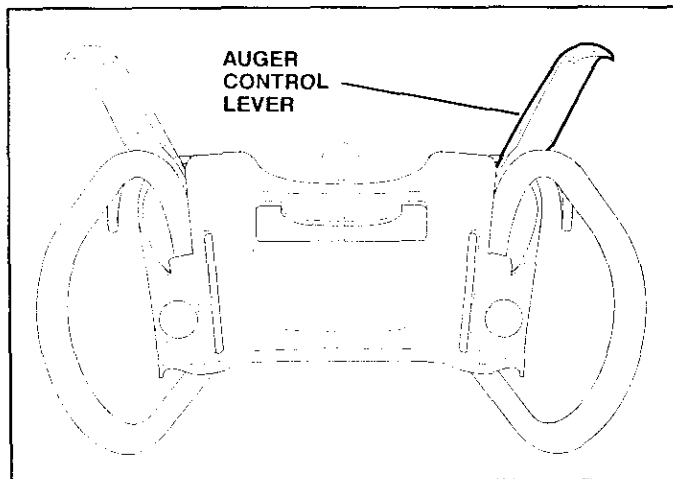

FIG. 14

TO MOVE FORWARD AND BACKWARD (See Fig. 15)

SELF-PROPELLING, forward and reverse movement of the snow thrower, is controlled by the traction drive control lever located on the left side handle.

- Squeeze traction drive control lever to handle to engage the drive system.
- Release traction drive control lever to stop the forward or reverse movement of the snow thrower.

SPEED and DIRECTION are controlled by the drive speed control lever.

- Press downward on the speed control lever and move lever to desired position **BEFORE** engaging the traction drive control lever. Be sure lever springs back and locks into desired position.

CAUTION: Do not move speed control lever when traction drive control lever is engaged. Damage to the snow thrower can result.

- Slower speeds are for heavier snow and faster speeds are for light snow and transporting the snow thrower. It is recommended that you use a slower speed until you are familiar with the operation of the snow thrower.

NOTE: When both traction drive and auger control levers are engaged, the traction drive control lever will lock the auger control lever in the engaged position. This will allow you to release your right hand from the handle and adjust the discharge chute direction without interrupting the snow throwing process.

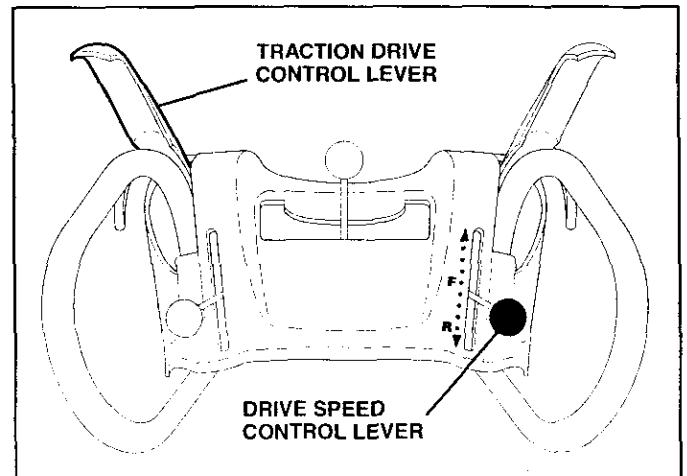

FIG. 15

POWER STEERING OPERATION (See Fig. 16)

Steering triggers are used to assist in steering your snow thrower. The triggers are located on the underside of each handle. When a trigger is squeezed, it disengages the drive wheel on that side of snow thrower and allows it to turn in that direction.

- To turn left – squeeze left side trigger.
- To turn right – squeeze right side trigger.

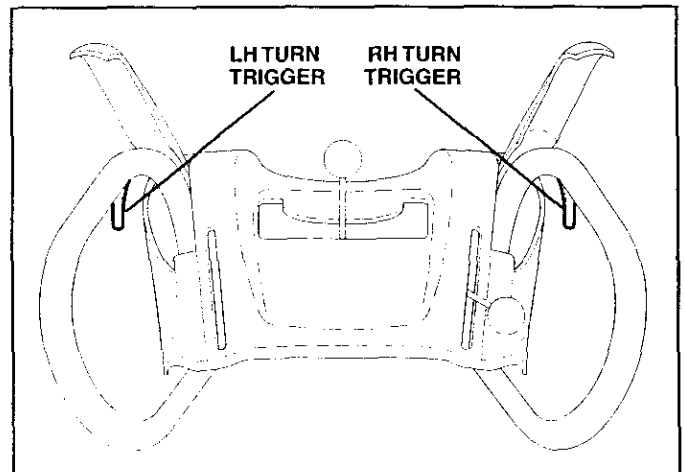

FIG. 16

OPERATION

TO ADJUST SKID PLATES (See Fig. 17)

NOTE: The wrench provided in your parts bag may be used to adjust the skid plates.

Skid plates are located on each side of the auger housing and adjust the clearance between the scraper bar and the ground surface. Adjust skid plates evenly to proper height for current surface conditions. For removal of snow in normal conditions, such as a paved driveway or sidewalk, place skid plates in the highest position (lowest scraper clearance) to give a 1/8" clearance between the scraper bar and the ground. Use a middle position if the surface to be cleared is uneven.

NOTE: It is not recommended to operate the snow thrower over gravel or rocky surfaces. Objects such as gravel, rocks or other debris, can easily be picked up and thrown by the impeller, which can cause serious personal injury, property damage or damage to the snow thrower.

- If snow thrower must be operated over gravel surface, use extra caution and be sure skid plates are adjusted to lowest (highest scraper clearance) position.
1. Shut off engine and wait for all moving parts to stop.
 2. Adjust skid plates by loosening the rear 1/2" hex nut only, then moving skid plate to desired position. Be sure both plates are adjusted evenly. Tighten securely.

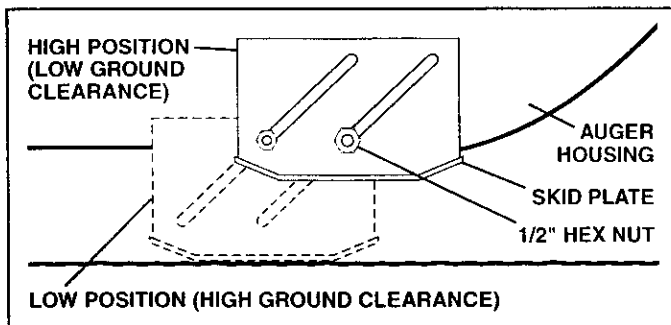

FIG. 17

SCRAPER BAR

The scraper bar is not adjustable, but is reversible. After considerable use it may become worn. When it has worn almost to the edge of the housing, it can be reversed, providing additional service before requiring replacement. Replace a damaged or worn scraper bar.

BEFORE STARTING THE ENGINE

CHECK ENGINE OIL LEVEL (See Fig. 18)

The engine on your snow thrower has been shipped, from the factory, already filled with oil.

1. Check engine oil with snow thrower on level ground.
 2. Remove oil fill cap/dipstick and wipe clean, reinsert the dipstick and screw tight, wait for a few seconds, remove and read oil level. If necessary, add oil until "FULL" mark on dipstick is reached. Do not overfill.
- To change engine oil, see "TO CHANGE ENGINE OIL" in the Maintenance section of this manual.

ADD GASOLINE (See Fig. 18)

- Fill fuel tank to bottom of tank filler neck. Do not overfill. Use fresh, clean, regular unleaded gasoline with a minimum of 87 octane. Do not mix oil with gasoline. Purchase fuel in quantities that can be used within 30 days to assure fuel freshness.



WARNING: Wipe off any spilled oil or fuel. Do not store, spill or use gasoline near an open flame.

CAUTION: Alcohol blended fuels (called gasohol or using ethanol or methanol) can attract moisture which leads to separation and formation of acids during storage. Acidic gas can damage the fuel system of an engine while in storage. To avoid engine problems, the fuel system should be emptied before storage of 30 days or longer. Drain the gas tank, start the engine and let it run until the fuel lines and carburetor are empty. Use fresh fuel next season. See Storage Instructions for additional information. Never use engine or carburetor cleaner products in the fuel tank or permanent damage may occur.

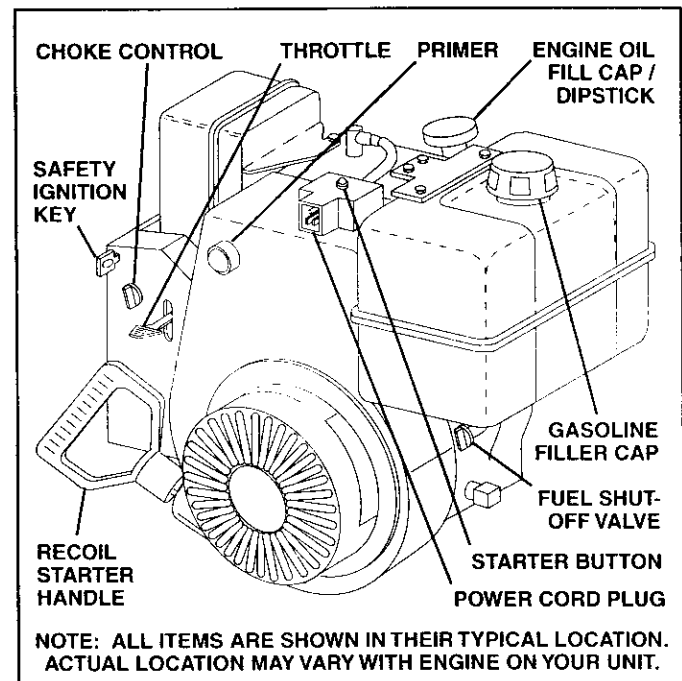

FIG. 18

TO START ENGINE

- Be sure fuel shut-off valve is in the OPEN position.
- Your snow thrower engine is equipped with both a 120 Volt A.C. electric starter and a recoil starter. The electric starter is equipped with a three-wire power cord and plug and is designed to operate on 120 Volt A.C. household current.
- Be sure your house is a 120 Volt A.C. three-wire grounded system. If you are uncertain, consult a licensed electrician.



WARNING: Do not use the electric starter if your house is not a 120 Volt A.C. three-wire grounded system. Serious personal injury or damage to your snow thrower could result.

OPERATION

COLD START - ELECTRIC STARTER

1. Insert safety ignition key into the ignition slot until it clicks. **DO NOT** turn the key. Keep the extra safety ignition key in a safe place.
2. Place throttle control in FAST position.
3. Rotate choke control to FULL position.
4. Connect the power cord to the engine.
5. Plug the other end of the power cord into a three-hole grounded 120 Volt A.C. receptacle.

NOTE: Do not use primer when starting engine with the electric starter.

6. Push starter button until engine starts.

IMPORTANT: Do not crank engine more than five continuous seconds between each time you try to start. Wait 5 to 10 seconds between each attempt.

7. When the engine starts, release the starter button and slowly move the choke control to the OFF position.
8. Disconnect the power cord from the receptacle first, then from the engine.

Allow the engine to warm up for a few minutes. Engine will not develop full power until it has reached normal operating temperature.

WARM START - ELECTRIC STARTER

Follow the steps above, keeping the choke control in the OFF position.

COLD START - RECOIL STARTER

1. Insert safety ignition key into the ignition slot until it clicks. **DO NOT** turn the key. Keep the extra safety ignition key in a safe place.
2. Place throttle control in FAST position.
3. Rotate choke control to FULL position.
4. Push the primer four (4) times if the temperature is below 15°F, or two (2) times if temperature is between 15° and 50°F. If temperature is above 50°F, priming is not necessary.

NOTE: Over priming may cause flooding, preventing the engine from starting. If you do flood the engine, wait a few minutes before attempting to start and **DO NOT** push the primer.

5. Pull recoil starter handle quickly. Do not allow starter rope to snap back.
6. When the engine starts, release the recoil starter handle and slowly move the choke control to the OFF position.

Allow the engine to warm up for a few minutes. Engine will not develop full power until it has reached normal operating temperature.

WARM START - RECOIL STARTER

Follow the steps above, keeping the choke in the OFF position. **DO NOT** push the primer.

BEFORE STOPPING

Run the engine for a few minutes to help dry off any moisture on the engine.

To avoid possible freeze-up of the starter, proceed as follows:

ELECTRIC STARTER

1. Connect the power cord to the engine.
2. Plug the other end of the power cord into a three-hole grounded 120 Volt A.C. receptacle.
3. While the engine is running, push starter button and spin the starter for several seconds.

NOTE: The unusual sound made while starter is spinning will not harm the engine or starter.

4. Disconnect the power cord from the receptacle first, then from the engine.

RECOIL STARTER

1. While the engine is running, pull the recoil starter handle with rapid, full arm strokes three or four times.

NOTE: The unusual sound made while pulling the recoil starter handle will not harm the engine or starter.

IF RECOIL STARTER HAS FROZEN

If the recoil starter has frozen and will not turn the engine, proceed as follows:

1. Grasp the recoil starter handle and slowly pull as much rope out of the starter as possible.
2. Release the recoil starter handle and let it snap back against the starter.

If the engine still fails to start, repeat the above steps or use the electric starter.

SNOW THROWING TIPS

- Always operate the snow thrower with the engine at full throttle. Full throttle offers the best performance.
- Go slower in deep, freezing or heavy wet snow. Use the drive speed control, **NOT** the throttle, to adjust speed.
- It is easier and more efficient to remove snow immediately after it falls.
- The best time to remove snow is the early morning. At this time the snow is usually dry and has not been exposed to the direct sun and warming temperatures.
- Slightly overlap each successive path to ensure all snow will be removed.
- Throw snow downwind whenever possible.
- Adjust the skid plates to proper height for current snow conditions. See "TO ADJUST SKID PLATES" in this section of this manual.
- For extremely heavy snow, reduce the width of snow removal by overlapping previous path and moving slowly.
- Keep engine clean and clear of snow during use. This will help air flow and extend engine life.
- After snow-throwing is completed, allow engine to run for a few minutes to melt snow and ice off the engine.
- Clean the entire snow thrower thoroughly after each use and wipe dry so it is ready for next use.



WARNING: Do not operate snow thrower if weather conditions impair visibility. Throwing snow during a heavy, windy snowstorm can blind you and be hazardous to the safe operation of the snow thrower.

MAINTENANCE

MAINTENANCE SCHEDULE		SERVICE INTERVALS						SERVICE DATES	
		BEFORE EACH USE	AFTER EACH USE	EVERY 25 HOURS OR EVERY SEASON	EVERY 50 HOURS	EVERY 100 HOURS	BEFORE STORAGE		
T H R O W E R	Check for Loose Fasteners	✓					✓		
	Clean / Inspect Snow Thrower		✓				✓		
	Check / Replace V-Belts			✓					
	Lubrication Chart			✓			✓		
E N G I N E	Check Engine Oil Level	✓							
	Change Engine Oil			✓					
	Inspect Muffler			✓					
	Check / Replace Spark Plug				✓				
	Empty Fuel Tank					✓			

GENERAL RECOMMENDATIONS

The warranty on this snow thrower does not cover items that have been subjected to operator abuse or negligence. To receive full value from the warranty, operator must maintain snow thrower as instructed in this manual. Some adjustments will need to be made periodically to properly maintain your snow thrower.

All adjustments in the Service and Adjustments section of this manual should be checked at least once each season.

- Once a year, you should replace the spark plug and check belts for wear. A new spark plug will help your engine run better and last longer.
- Follow the maintenance schedule in this manual.

NOTE: Use only Original Equipment Manufacturer (OEM) parts to service this unit. Failure to do so can cause the unit to malfunction and pose a risk of injury to the operator.

BEFORE EACH USE

1. Check engine oil level.
2. Check for loose fasteners.
3. Check controls to be sure they are functioning properly.

LUBRICATION

Keep your snow thrower well lubricated (See "LUBRICATION CHART").

LUBRICATION CHART

- ① SAE 30 Motor Oil
- ② See "ENGINE" in Maintenance section

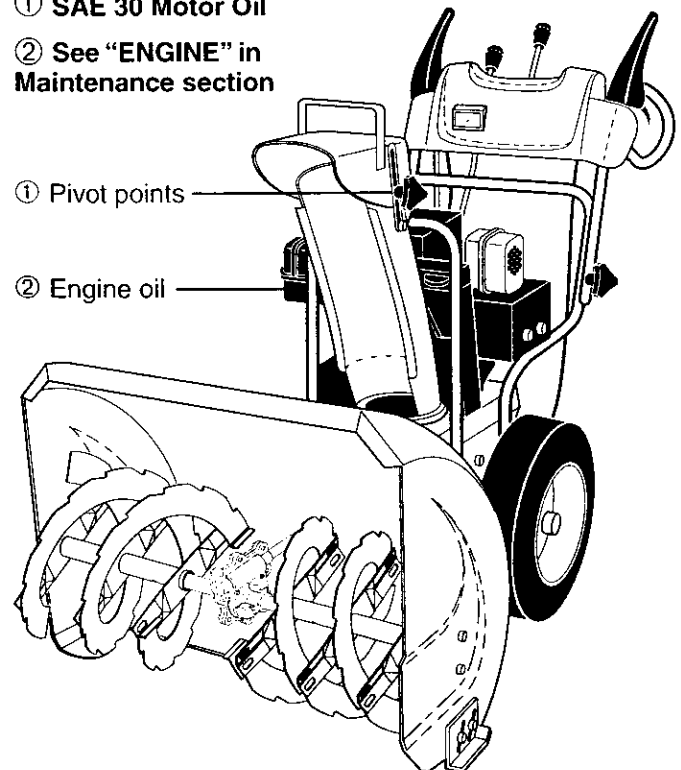

SNOW THROWER

Always observe the safety rules when performing any maintenance.

TIRES

- Maintain proper air pressure in both tires (See "PRODUCT SPECIFICATIONS" section in this manual).

- Keep tires free of gasoline and oil, which can harm rubber.

NOTE: To seal tire punctures and prevent flat tires due to slow leaks, tire sealant may be purchased from your local parts dealer. Tire sealant also prevents tire dry rot and corrosion.

MAINTENANCE

V-BELTS

Check V-belts for deterioration and wear after every 50 hours of operation and replace if necessary. The belts are not adjustable. Replace belts if they begin to slip from wear. (See "TO REMOVE BELT COVER" in the Service and Adjustments section of this manual).

The V-belts on your snow thrower are of special construction and should be replaced by original equipment manufacturer (OEM) belts available from your nearest dealer. Using other than OEM belts can cause personal injury or damage to the snow thrower.

AUGER GEAR CASE

- The gear case was filled with lubricant to the proper level at the factory. The only time the lubricant needs attention is if service has been performed on the gear case.
- If lubricant is required, use only Ronex ED #1 grease.

TRACTION DRIVE SYSTEM

DO NOT lubricate the drive components inside the snow thrower. The sprockets, hex shafts, drive disc and friction wheel require no lubrication. The bearings and bushings are lifetime lubricated and require no maintenance.

CAUTION: Any lubricating of the above components can cause contamination of the friction wheel and damage to the drive system of your snow thrower.

ENGINE

See engine manual.

LUBRICATION

Use only high quality detergent oil rated with API service classification SF-SJ. Select the oil's SAE viscosity grade according to your expected operating temperature.

NOTE: Although multi-viscosity oils (5W30, 10W30 etc.) improve starting in cold weather, these multi-viscosity oils will result in increased oil consumption when used above 32°F. Check your engine oil level more frequently to avoid possible engine damage from running low on oil.

Change the oil after every 50 hours of operation or at least once a year if the snow thrower is not used for 50 hours in one year.

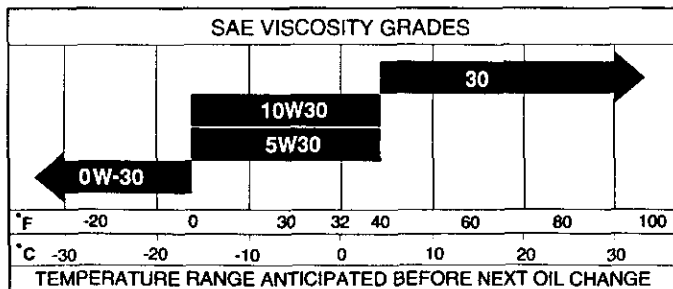

Check the crankcase oil level before starting the engine and after each five (5) hours of continuous use. Tighten oil fill cap / dipstick securely each time you check the oil level.

TO CHANGE ENGINE OIL

Determine temperature range anticipated before next oil change. All oil must meet API service classification SF-SJ.

- Be sure snow thrower is on level surface.
- Oil will drain more freely when warm.
- Catch oil in a suitable container.

NOTE: The left side wheel may be removed from snow thrower for easier access to the oil drain plug and placement of a suitable container. The unit tilted, resting on the frame with the left wheel removed, will help drain any oil trapped inside the engine. (See "TO REMOVE WHEELS" in the Service and Adjustments section of this manual).

1. Disconnect spark plug wire from spark plug and place wire where it cannot come in contact with spark plug.
2. Clean area around drain plug.
3. Remove drain plug and drain oil in a suitable container.
4. Install drain plug and tighten securely.
5. Wipe off any spilled oil from snow thrower and engine.
6. Install left wheel (if removed for draining oil). Be sure to install klick pin into proper hole in wheel axle (See "TO REMOVE WHEELS" in the Service and Adjustments section of this manual).
7. Remove oil fill cap/dipstick. Be careful not to allow dirt to enter the engine.
8. Refill engine with oil through oil dipstick tube. Pour slowly. Do not overfill. For approximate capacity see "PRODUCT SPECIFICATIONS" section of this manual.
9. Use gauge on oil fill cap/dipstick for checking level. Be sure dipstick cap is tightened securely for accurate reading. Keep oil at "FULL" line on dipstick.
10. Wipe off any spilled oil.

MUFFLER

Inspect and replace corroded muffler as it could create a fire hazard and/or damage.

SPARK PLUG

Replace spark plug at the beginning of each season or after every 100 hours of operation, whichever occurs first. Spark plug type and gap setting are shown in the "PRODUCT SPECIFICATIONS" section of this manual.

CLEANING

IMPORTANT: For best performance, keep snow thrower housing free of any dirt or trash. Clean the outside of your snow thrower after each use.



WARNING: Disconnect spark plug wire from spark plug and place wire where it cannot come in contact with spark plug.

- Keep finished surfaces/wheels free of gasoline, oil, etc.
- We do not recommend using a garden hose to clean your snow thrower unless the electrical system, muffler and carburetor are covered to keep water out. Water in engine can result in shortened engine life.

SERVICE AND ADJUSTMENTS

WARNING: To avoid serious injury, before performing any service or adjustments:



1. Be sure throttle is in STOP position.
2. Remove safety ignition key.
3. Make sure the augers and all moving parts have completely stopped.
4. Disconnect spark plug wire from spark plug and place wire where it cannot come in contact with plug.

SNOW THROWER

TO ADJUST SNOW THROWER HEIGHT

See "TO ADJUST SKID PLATES" and "SCRAPER BAR" in the Operation section of this manual.

CHUTE DEFLECTOR

The chute deflector, attached to the top of the discharge chute, is provided to direct discharging snow away from the operator. If the deflector becomes damaged, it should be replaced.



WARNING: To avoid serious injury, never operate your snow thrower with the deflector removed or damaged.

- To change direction and/or distance snow is discharged, see "TO CONTROL SNOW DISCHARGE" in the Operation section of this manual.

SHEAR BOLTS (See Fig. 20)

AUGER SHEAR BOLTS

Both right and left-hand augers are secured to the auger shaft with a shoulder/shear bolt and hex nut. Should a foreign object or ice become lodged in the augers, the shear bolts are designed to break, preventing damage to any other components. If one or both augers do not turn when auger control lever is engaged, check to see if one or both of the bolts have sheared. To replace the shear bolts:

1. Disengage all controls and move throttle control to STOP position. Wait for all moving parts to stop.
2. Disconnect spark plug wire from spark plug and place it where it cannot come in contact with spark plug.
3. Align hole in auger hub with hole in auger shaft and install a new 1/4-20 x 2" shoulder/shear bolt. Install 1/4-20 lock nut and tighten securely.

CAUTION: Do not substitute. Use only original equipment shear bolts as supplied with your snow thrower.

4. Connect spark plug wire to spark plug.

IMPELLER SHEAR BOLTS

The impeller is secured to the impeller shaft with two (2) capscrew/shear bolts and hex nuts. Should a foreign object or ice become lodged in the impeller, the capscrews are designed to break, preventing damage to any other components. If impeller does not turn when auger control lever is engaged, check to see if the capscrews have sheared. To replace the capscrew/shear bolts:

1. Disengage all controls and move throttle control to STOP position. Wait for all moving parts to stop.
2. Disconnect spark plug wire from spark plug and place it where it cannot come in contact with spark plug.
3. Align holes in impeller hub with holes in impeller shaft and install two (2) new 1/4-20 x 1-5/8" capscrew/shear bolts. Install 1/4-20 locknuts and tighten securely.

CAUTION: Do not substitute. Use only original equipment capscrew/shear bolts as supplied with your snow thrower.

4. Connect spark plug wire to spark plug.

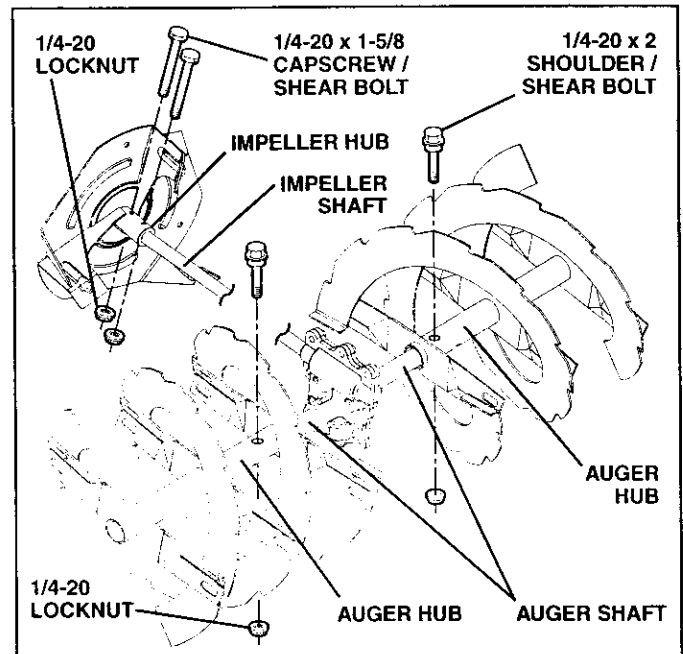

FIG. 20

TO REMOVE BELT COVER (See Fig. 21)

1. Remove the two (2) screws securing belt cover to frame.
 2. Remove belt cover.
- Replace belt cover by installing cover and screws and tighten securely.

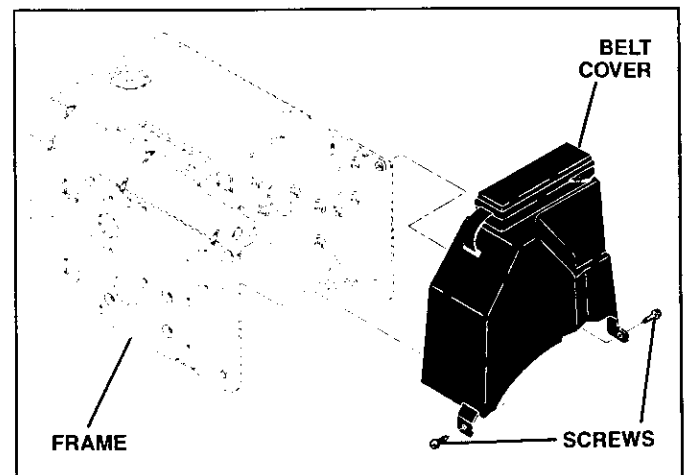

FIG. 21

SERVICE AND ADJUSTMENTS

TO REPLACE BELTS (See Fig. 22)

The auger and traction drive belts are not adjustable. If the belts are damaged or begin to slip from wear, they should be replaced. It is recommended that the belt(s) be replaced by a qualified service center.

NOTE: It is recommended that both the auger and traction drive belt be replaced at the same time.

The V-belts on your snow thrower are of special construction and should be replaced by original equipment manufacturer (OEM) belts available from your nearest dealer. Using other than OEM belts can cause personal injury or damage to the snow thrower.

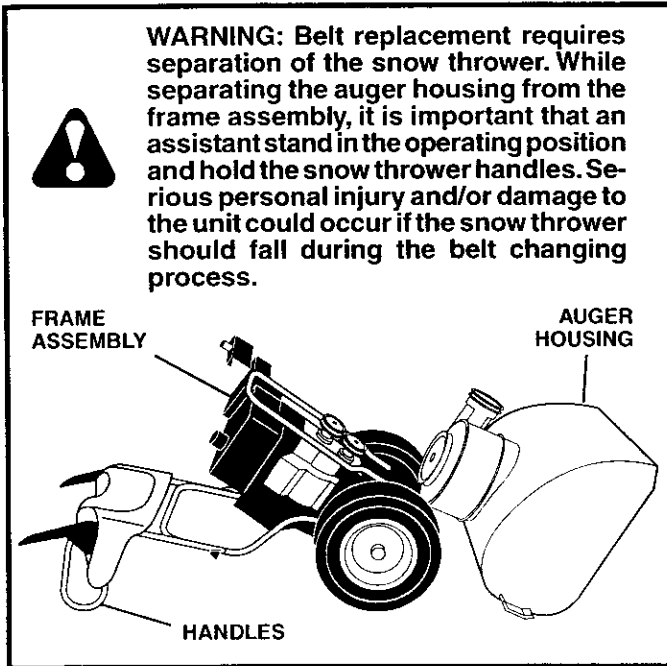

1. REMOVE GASOLINE FROM FUEL TANK - Drain gasoline from fuel tank into a suitable container, outdoors, away from fire or flame. Wipe up any spilled gasoline.
2. REMOVE DISCHARGE CHUTE - Loosen locknut securing chute rotator head to mounting bracket only enough to allow chute rotator head to be raised and discharge chute to be removed from snow thrower.
3. REMOVE BELT COVER - See "TO REMOVE BELT COVER" in this section of this manual.
4. REMOVE ENGINE PULLEY - Remove bolt, lockwasher and flat washer securing pulley to engine crankshaft. Remove outside (auger) pulley only from crankshaft.
5. SEPARATE SNOW THROWER - With your assistant standing in the operating position holding the handles, remove the two (2) bolts and lock washers holding auger housing and frame together.



WARNING: As the last bolt is removed, have your assistant carefully lower the handles down to the ground.

6. REMOVE AUGER BELT from around pulley.
7. RELIEVE TENSION ON TRACTION DRIVE BELT IDLER and remove traction drive belt from around pulleys.

HINT: Insert a 3/8" drive ratchet (in the "ON" position) into the square hole in idler arm and rotate ratchet clockwise to relieve tension.

8. With tension relieved on idler, install new traction drive belt around pulleys and inside belt keepers.
9. Place auger belt around and inside the groove of auger pulley only.
10. While your assistant slowly raises handles to rejoin the auger housing and frame assembly, pull up on the auger belt and squeeze sides together above pulley so belt is fully seated in groove of pulley.
11. Bring snow thrower completely together and check carefully for proper routing of belts. If auger belt has become dislodged from the pulley (by catching the idler arm bracket while bringing snow thrower together), separate the snow thrower and repeat step 10. Belt must be fully seated in pulley groove when bringing the snow thrower together.
12. Install the two (2) hex bolts and lock washers and tighten securely.
13. INSTALL ENGINE PULLEY - Place belt in pulley groove and slide pulley on crankshaft. Install flat washer, lockwasher and bolt and tighten securely (30-35 ft. lbs. torque). Make sure belt is inside belt keeper.
14. INSTALL BELT COVER and two (2) screws. Tighten securely.
15. INSTALL DISCHARGE CHUTE - See "INSTALL DISCHARGE CHUTE / CHUTE ROTATER HEAD" in the Assembly / Pre-Operation section of this manual.

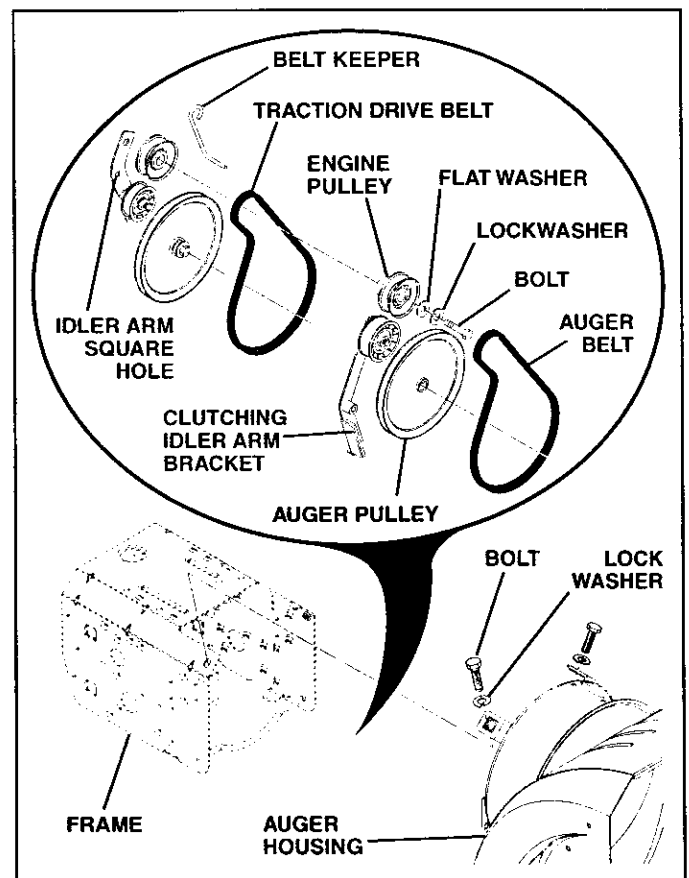

FIG. 22

TO REMOVE WHEELS (See Fig. 23)

- Remove the klik pin and remove wheel from axle.

IMPORTANT: When installing wheel, be sure to use the axle hole closest to the end of the shaft – *do not* use the hole in the wheel hub (if equipped). Inner hole in axle and hole in wheel hub are not used for your model snow thrower.

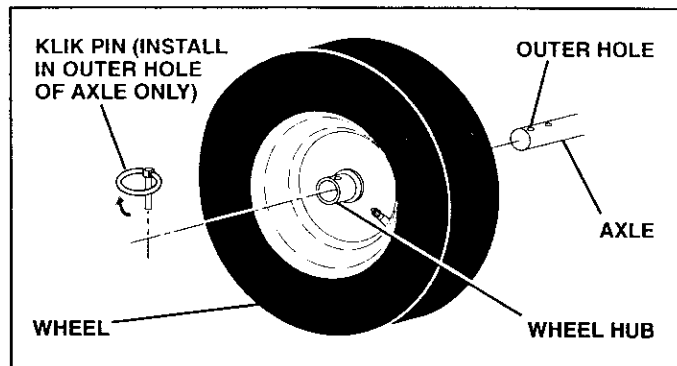

FIG. 23

NOTE: To seal punctures or prevent flat tires due to slow leaks, tire sealant may be purchased from your local parts dealer. Tire sealant also prevents tire dry rot and corrosion.

ENGINE

See engine manual.

CARBURETOR

Your carburetor is not adjustable. Engine performance should not be affected at altitudes up to 7,000 feet (2,134 meters). If your engine does not operate properly due to suspected carburetor problems, take your snow thrower to a qualified service center.

ENGINE SPEED

Never tamper with the engine governor, which is factory set for proper engine speed. Overspeeding the engine above the factory high speed setting can be dangerous and will void the warranty. If you think the engine-governed high speed needs adjusting, contact a qualified service center, which has proper equipment and experience to make any necessary adjustments.

STORAGE

Immediately prepare your snow thrower for storage at the end of the season or if the unit will not be used for 30 days or more.



WARNING: Never store the snow thrower with gasoline in the tank inside a building where fumes may reach an open flame, spark or pilot light as on a furnace, water heater, clothes dryer or gas appliance. Allow the engine to cool before storing in any enclosure.

SNOW THROWER

When snow thrower is to be stored for a period of time, clean it thoroughly, remove all dirt, grease, leaves, etc. Store in a clean, dry area.

1. Clean entire snow thrower (See "CLEANING" in the Maintenance section of this manual).
2. Inspect and replace belts, if necessary (See "TO REPLACE BELTS" in the Service and Adjustments section of this manual).
3. Lubricate as shown in the Maintenance section of this manual.
4. Be sure that all nuts, bolts, screws, and pins are securely fastened. Inspect moving parts for damage, breakage and wear. Replace if necessary.
5. Touch up all rusted or chipped paint surfaces; sand lightly before painting.

ENGINE

See engine manual.

FUEL SYSTEM

IMPORTANT: It is important to prevent gum deposits from forming in essential fuel system parts such as carburetor, fuel hose, or tank during storage. Also, alcohol blended fuels (called gasohol or using ethanol or methanol) can attract moisture which leads to separation and formation of acids during storage. Acidic gas can damage the fuel system of an engine while in storage.

1. Drain the fuel tank.
 2. Start the engine and let it run until the fuel lines and carburetor are empty.
- Never use engine or carburetor cleaner products in the fuel tank or permanent damage may occur.
 - Use fresh fuel next season.

NOTE: Fuel stabilizer is an acceptable alternative in minimizing the formation of fuel gum deposits during storage. Add stabilizer to gasoline in fuel tank or storage container. Always follow the mix ratio found on stabilizer container. Run engine at least 10 minutes after adding stabilizer to allow the stabilizer to reach the carburetor. Do not drain the gas tank and carburetor if using fuel stabilizer.

ENGINE OIL

Drain oil (with engine warm) and replace with clean engine oil. (See "ENGINE" in the Maintenance section of this manual).

CYLINDER

1. Remove spark plug.
2. Pour one ounce (29 ml) of oil through spark plug hole into cylinder.
3. Pull recoil starter handle slowly a few times to distribute oil.
4. Replace with new spark plug.

OTHER

- Do not store gasoline from one season to another.
- Replace your gasoline can if your can starts to rust. Rust and/or dirt in your gasoline will cause problems.
- If possible, store your snow thrower indoors and cover it to protect it from dust and dirt.
- Cover your snow thrower with a suitable protective cover that does not retain moisture. Do not use plastic. Plastic cannot breathe, which allows condensation to form and will cause your snow thrower to rust.

IMPORTANT: Never cover snow thrower while engine/exhaust area is still warm.

TROUBLESHOOTING

See appropriate section in manual unless directed to a qualified service center.

PROBLEM	CAUSE	CORRECTION
Does not start	<ol style="list-style-type: none"> 1. Fuel shut-off valve (if so equipped) in OFF position. 2. Safety ignition key is not inserted. 3. Out of fuel. 4. Throttle in STOP position. 5. Choke in OFF position. 6. Primer not depressed. 7. Engine is flooded. 8. Spark plug wire is disconnected. 9. Bad spark plug. 10. Stale fuel. 11. Water in fuel. 	<ol style="list-style-type: none"> 1. Turn fuel shut-off valve to OPEN position. 2. Insert safety ignition key. 3. Fill fuel tank. 4. Move throttle to FAST position. 5. Move to FULL position. 6. Prime as instructed in the Operation section of this manual. 7. Wait a few minutes before restarting, DO NOT prime. 8. Connect wire to spark plug. 9. Replace spark plug. 10. Drain fuel tank and carburetor, refill tank with fresh gasoline. 11. Drain fuel tank and carburetor, refill tank with fresh gasoline.
Loss of power	<ol style="list-style-type: none"> 1. Spark plug wire loose. 2. Throwing too much snow. 3. Fuel tank cap is covered with ice or snow. 4. Dirty or clogged muffler. 	<ol style="list-style-type: none"> 1. Reconnect spark plug wire. 2. Reduce speed and width of swath. 3. Remove ice and snow on and around fuel tank cap. 4. Clean or replace muffler.
Engine idles or runs roughly	<ol style="list-style-type: none"> 1. Choke is in FULL position. 2. Blockage in fuel line. 3. Stale fuel. 4. Water in fuel. 5. Carburetor is in need of adjustment or overhaul. 	<ol style="list-style-type: none"> 1. Move choke to OFF position. 2. Clean fuel line. 3. Drain tank and refill with fresh, clean fuel. 4. Drain fuel tank and carburetor, refill tank with fresh gasoline. 5. Contact a qualified service center.
Excessive vibration	<ol style="list-style-type: none"> 1. Loose parts or damaged augers or impeller. 	<ol style="list-style-type: none"> 1. Tighten all fasteners. Replace damaged parts. If vibration remains, contact a qualified service center.
Recoil starter is hard to pull	<ol style="list-style-type: none"> 1. Frozen recoil starter. 	<ol style="list-style-type: none"> 1. See "IF RECOIL STARTER HAS FROZEN" in the Operation section of this manual.
Loss of traction drive / slowing of drive speed	<ol style="list-style-type: none"> 1. Drive belt is worn. 2. Drive belt is off of pulley. 3. Friction drive wheel is worn. 	<ol style="list-style-type: none"> 1. Check / replace drive belt. 2. Check / reinstall drive belt. 3. Contact a qualified service center.
Loss of snow discharge or slowing of snow discharge	<ol style="list-style-type: none"> 1. Auger belt is off of pulley. 2. Auger belt is worn. 3. Clogged discharge chute. 4. Augers / impeller jammed. 	<ol style="list-style-type: none"> 1. Check / reinstall auger belt. 2. Check / replace auger belt. 3. Clean snow chute. 4. Remove debris or foreign object from augers / impeller.

REPAIR PARTS

SNOW THROWER - MODEL NUMBER PP8527ESA

AUGER HOUSING / IMPELLER ASSEMBLY

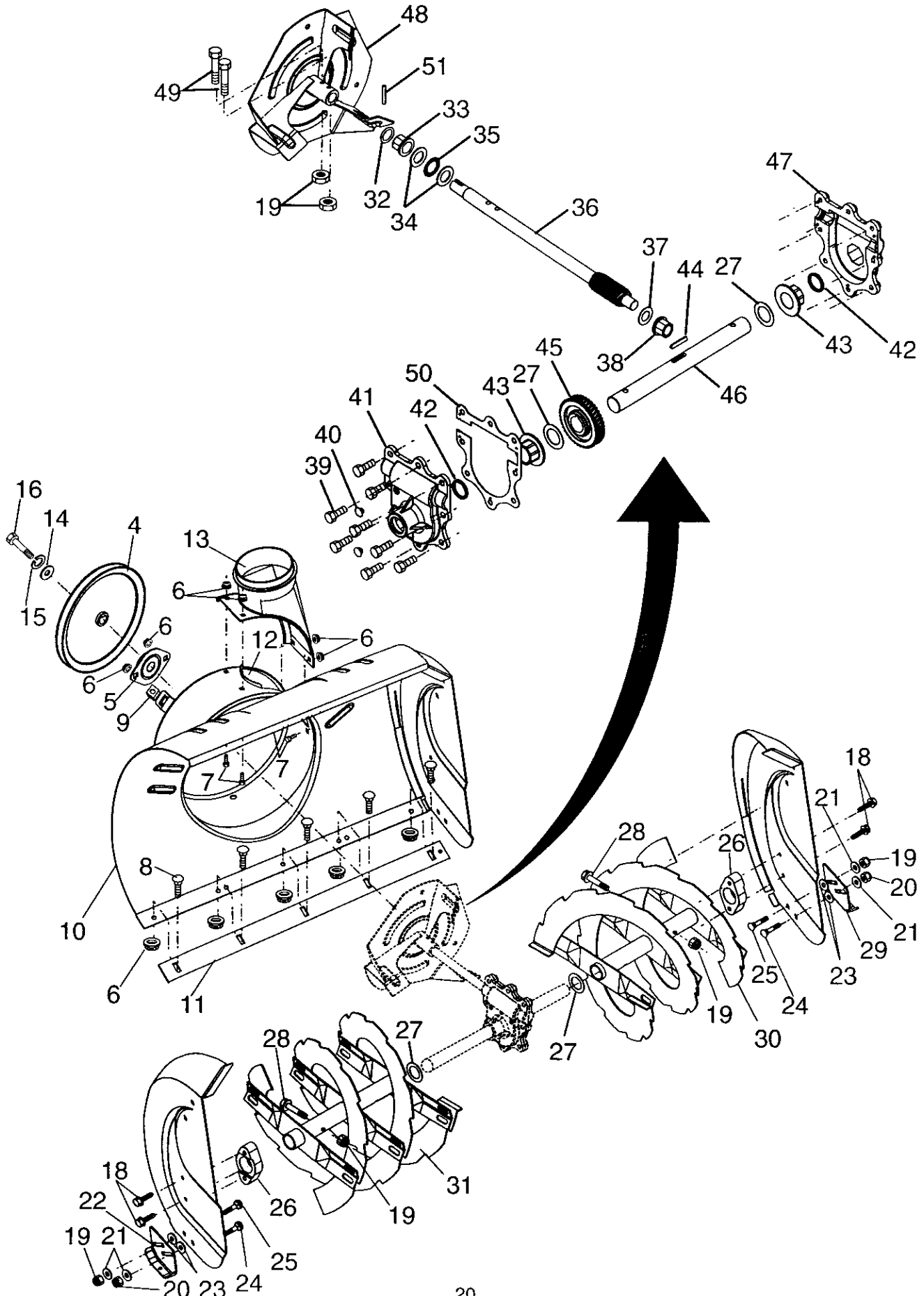

REPAIR PARTS**SNOW THROWER - MODEL NUMBER PP8527ESA****AUGER HOUSING / IMPELLER ASSEMBLY**

KEY NO.	PART NO.	DESCRIPTION
2	053847	Washer, Flat
4	181083	Pulley, Impeller
5	175323	Bearing Assembly, Flange
6	155377	Nut, Hex Flange 5/16-18
7	180355	Bolt, Flat Head, Carriage 5/16-18 x 5/8
8	72270505	Bolt, Carriage 5/16-18 x 5/8
9	178820	Nut, Cage 3/8-16
10	178826X428	Housing, Auger
11	178690X479	Bar, Scraper
12	178675X008	Bracket, Corner Discharge
13	175322	Base, Discharge Chute
14	19111507	Washer, Flat
15	10040500	Washer, Lock 5/16
16	74950512	Screw, Hex Head 5/16-18 x 3/4
18	179582	Screw, Hex Head 5/16 x 1
19	73800400	Nut, Hex Lock 1/4-20
20	73800500	Nut, Hex Lock 5/16-18
21	155415	Washer, Flat
22	178777X479	Skid Plate, RH
23	179246	Washer, Nylon, Friction
24	72270506	Bolt, Carriage 5/16-18 x 3/4
25	185600	Bolt, Shoulder
26	174658	Bearing, Auger
27	174697	Washer, Thrust, 1"
28	187494	Bolt, Shear
29	174762X479	Skid Plate, LH
30	178763X479	Auger Assembly, RH
31	178697X479	Auger Assembly, LH
32	174699	O-Ring
33	174700	Bushing, Flange 3/4
34	174681	Washer, Thrust 3/4
35	174684	Bearing, Thrust 3/4
36	174660	Shaft, Impeller
37	174683	Washer, Thrust 5/8
38	174686	Bushing, Flange 5/8
39	150078	Screw, Hex Head 5/16-18 x 3/4
40	86447	Plug, Case
41	174688	Housing, Gearbox, RH
42	174698	Seal, Oil
43	174701	Bushing, Flange, 1"
44	178879	Key, Square 1/4 x 1/4 x 7/8
45	174659	Gear, Worm
46	174657	Shaft, Auger
47	174687	Housing, Gearbox, LH
48	175321X479	Impeller Assembly
49	74780426	Screw, Hex Head 1/4-20 x 1-5/8
50	175311	Gasket, Gearbox
51	7836M	Pin, Roll 3/16 x 1-1/8

NOTE: All component dimensions given in U.S. inches
1 inch = 25.4 mm

REPAIR PARTS

SNOW THROWER - MODEL NUMBER PP8527ESA

CONTROL PANEL / DISCHARGE CHUTE

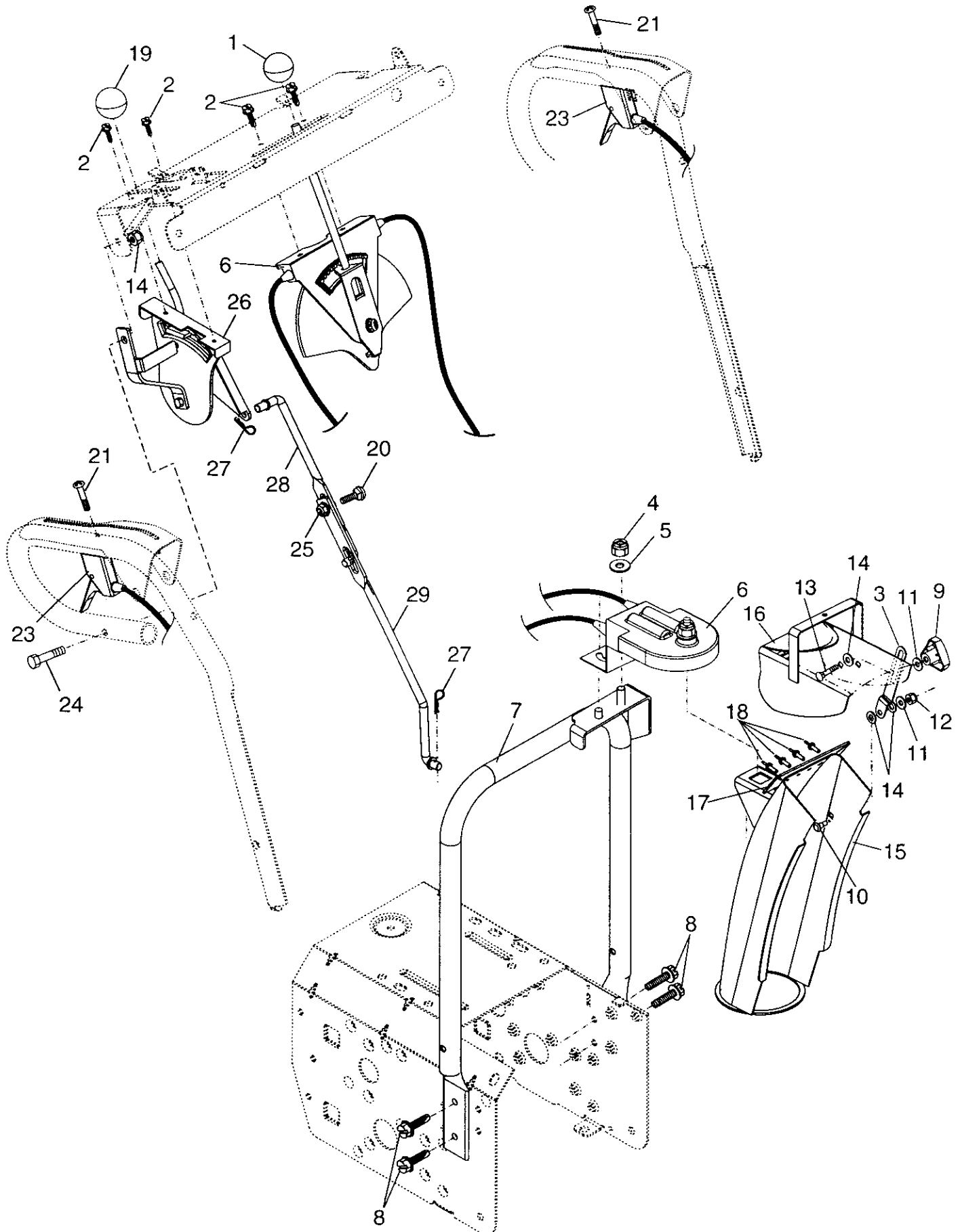

REPAIR PARTS**SNOW THROWER - MODEL NUMBER PP8527ESA****CONTROL PANEL / DISCHARGE CHUTE**

KEY NO.	PART NO.	DESCRIPTION
1	183334	Knob, Lever
2	17501010	Screw #10-24 x 5/8
3	179096X479	Strap, Slotted
4	73800600	Nut, Lock 3/8-16
5	19131316	Washer, Flat 3/8
6	178659	Control Assembly, Chute Rotater
7	178638X479	Support, Pivot
8	150078	Screw, Hex Head 5/16-18 x 3/4
9	180453	Knob, Deflector
10	185600	Bolt, Shoulder
11	53847	Washer, Flat
12	73800400	Nut, Lock 1/4-20
13	72250505	Bolt, Carriage 5/16-18
14	179246	Nut, Lock 5/16-18
15	178628X428	Chute Assembly
16	178633X428	Deflector Assembly
17	179145	Seal, Deflector
18	128415	Rivet, Blind
19	183333	Knob, Speed Control Lever
20	72270506	Bolt, Carriage 5/16-18 x 3/4
21	74041024	Screw #10-24 x 1-1/2
23	187691	Control Assembly, Power Steering
24	74780528	Screw, Hex Head 5/16-18 x 1-3/4
25	155377	Nut, Lock 5/16-18
26	179257	Lever Assembly, Speed Control
27	169675	Retainer, Hairpin
28	180445	Rod, Upper, Speed Control
29	187716	Rod, Lower, Speed Control

NOTE: All component dimensions given in U.S. inches
1 inch = 25.4 mm

REPAIR PARTS HANDLES

SNOW THROWER - MODEL NUMBER PP8527ESA

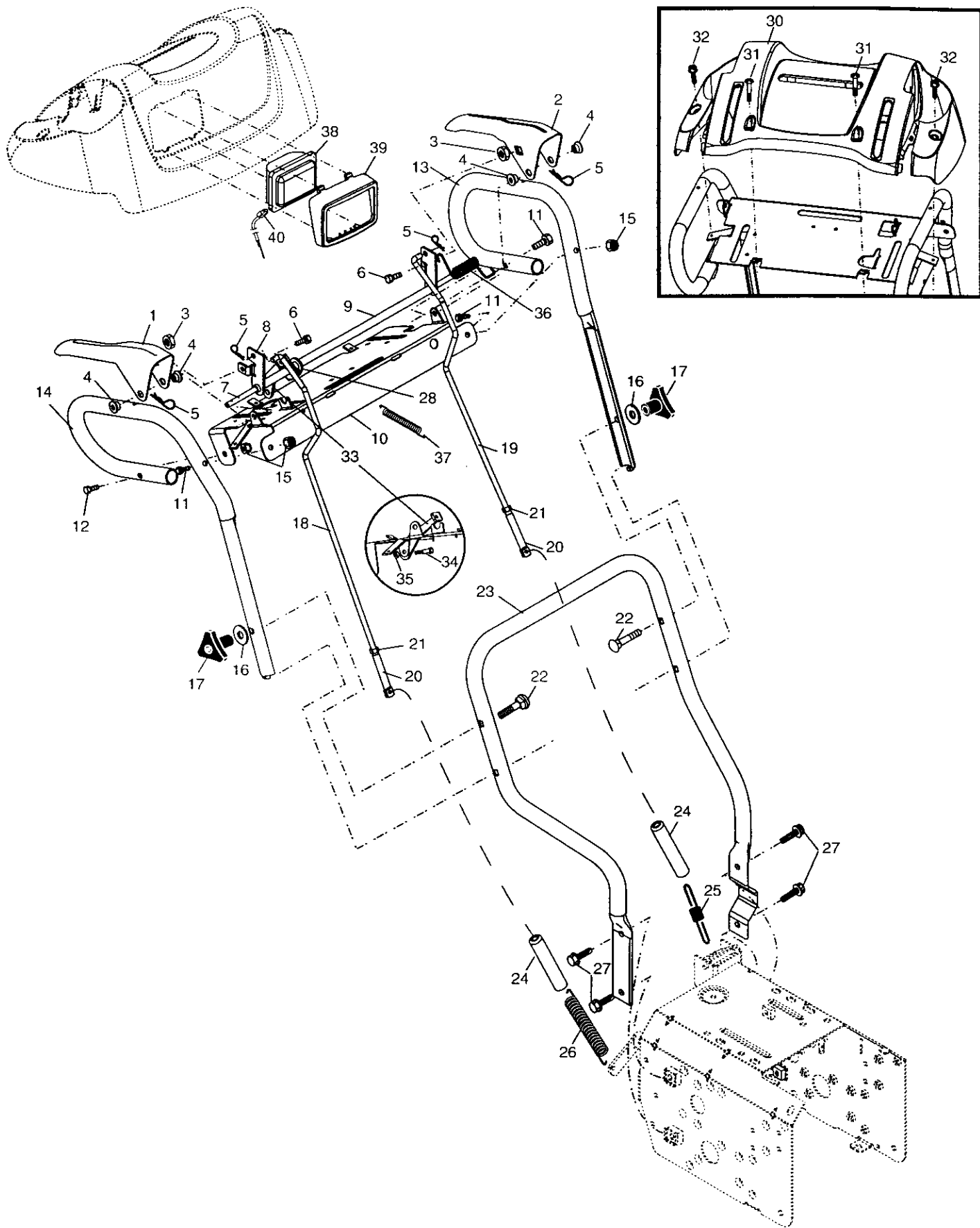

**REPAIR PARTS
HANDLES**

SNOW THROWER - MODEL NUMBER PP8527ESA

KEY NO.	PART NO.	DESCRIPTION
1	178875X479	Lever, Auger Control, RH
2	178648X479	Lever, Traction Drive Control, LH
3	179439	Nut, Cage 1/4-20
4	178888	Bushing, Flange
5	169675	Retainer, Hairpin
6	180402	Screw, Hex Head 1/4-20 x 3/4
7	178652	Rod, Interlock
8	184003	Tube Assembly, Interlock, RH
9	178651	Tube Assembly, Interlock, LH
10	178645X479	Panel, Control
11	74780524	Screw, Hex Head 5/16-18 x 1-1/2
12	74780528	Screw, Hex Head 5/16-18 x 1-3/4
13	178646X479	Handle Tube, LH
14	178696X479	Handle Tube, RH
15	73800500	Nut, Lock 5/16-18
16	19131316	Washer, Flat 3/8
17	178899	Knob, Handle
18	179093	Rod, Auger Control
19	179098	Rod, Traction Control
20	180428	End, Control Rod
21	73350500	Nut, Hex, Jam 5/16-18
22	72120618	Bolt, Carriage 3/8-16 x 2-1/4
23	178825X479	Handle Tube, Lower
24	180447	Sleeve, Spring
25	180926	Spring, Traction Drive
26	178669	Spring, Auger Control
27	71210616	Screw, Hex Head 3/8-16 x 1
28	180494	Clip, Panel
30	183346	Console, Panel
31	175262	Screw, Hex Head, Tapping #10-24 x 1-1/4
32	184471	Screw, Hex Head, Tapping #10-24 x 1/2
33	175339X008	Latch, Interlock
34	183518	Bolt, Shoulder
35	68038	Nut, Lock 1/4-20
36	178831	Spring, Torsion
37	178658	Spring, Interlock
38	180927	Headlight, Halogen
39	178668	Bezel, Headlight
40	178770	Harness, Headlight (Halogen)

NOTE: All component dimensions given in U.S. inches
1 inch = 25.4 mm

REPAIR PARTS DRIVE

SNOW THROWER - MODEL NUMBER PP8527ESA

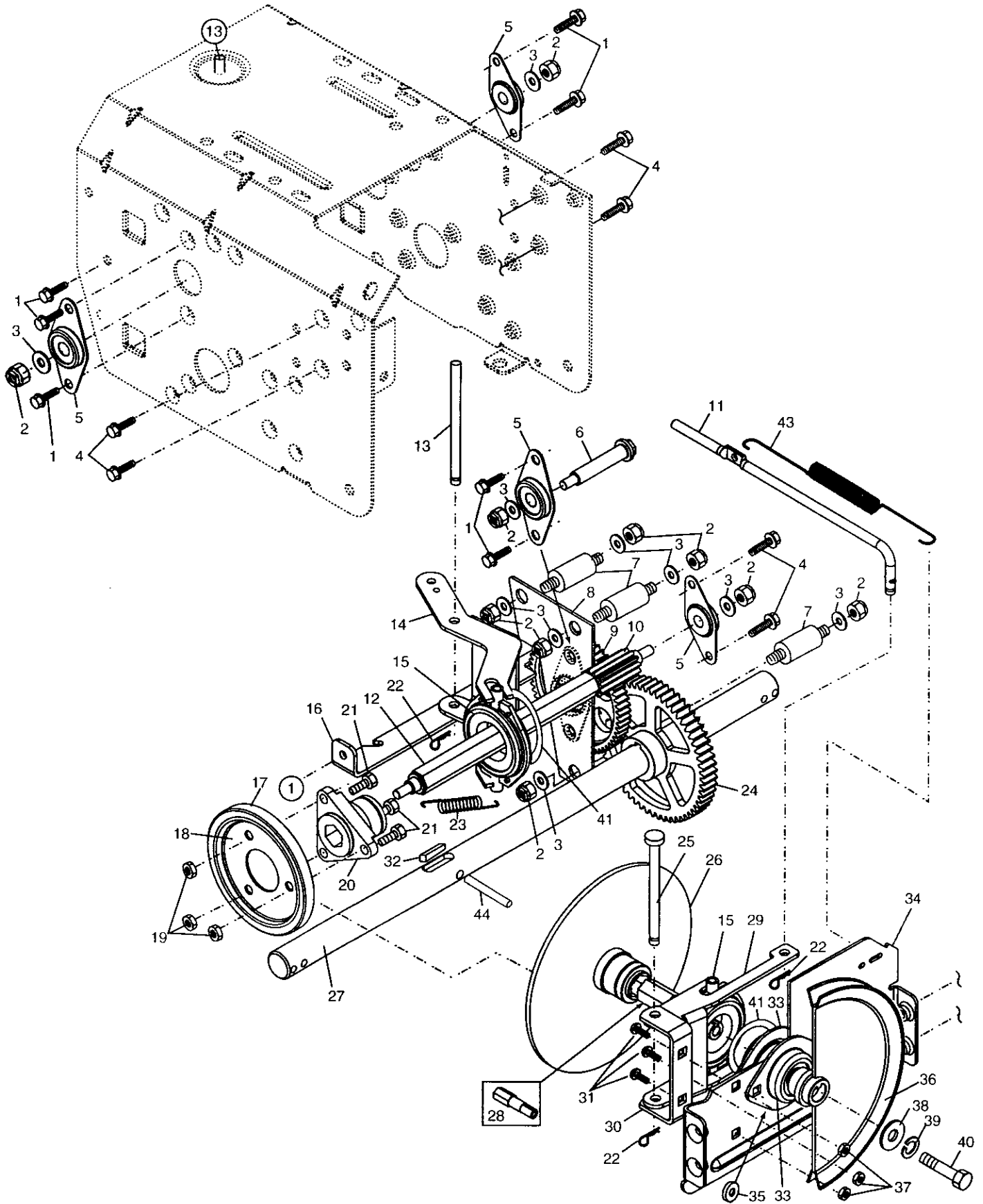

**REPAIR PARTS
DRIVE**

SNOW THROWER - MODEL NUMBER PP8527ESA

KEY NO.	PART NO.	DESCRIPTION
1	146315	Screw, Hex Head 5/16-18 x 3/4
2	73800500	Nut, Lock 5/16-18
3	155415	Washer, Flat
4	17490508	Screw, Hex Head 5/16-18 x 1/2
5	180017	Bearing, Flange
6	180134	Shaft, Auxiliary
7	179270	Spacer, Plate
8	179269X479	Plate, Auxiliary
9	180082	Gear, Intermediate (12/58)
10	180065	Gear, Pinion
11	187714	Rod, Clutch
12	180066	Shaft, Long, Hex
13	178807	Pin, Pivot
14	178619X479	Lever, Shifter / Wheel
15	175344	Trunnion Bearing Assembly
16	186951X479	Bracket, Pivot, Shift
17	179831	Ring, Rubber Wheel
18	178616X479	Plate, Rubber Wheel
19	73930500	Nut, Lock 5/16-18
20	178613	Hub, Rubber Wheel
21	74760514	Screw, Hex Head 5/16-18 x 7/8
22	85179	Retainer, Hairpin
23	180135	Spring, Bias
24	180081	Gear, Axle (58 Teeth)
25	178695	Pin, Pivot Lever
26	175341	Plate Assembly, Drive
27	188227	Shaft, Axle
28	175340	Shaft, Short Hex
29	175350X479	Lever, Shifter Plate
30	175349X479	Bracket, Shifter Support
31	72270505	Bolt, Carriage 5/16-18 x 5/8
32	178879	Key, Square 1/4 x 1/4 x 7/8
33	175323	Bearing, Flange
34	175338X479	Plate, Drive Mounting
35	182504	Spacer, Bearing
36	175348	Pulley, Traction Drive
37	155377	Nut, Lock 5/16-18
38	19111507	Washer, Flat
39	10040500	Washer, Lock 5/16
40	74950512	Screw, Hex Head 5/16-18 x 3/4
41	12000012	Ring, Retaining
43	179095	Spring, Return
44	9465M	Pin, Roll

NOTE: All component dimensions given in U.S. inches
1 inch = 25.4 mm

REPAIR PARTS

SNOW THROWER - MODEL NUMBER PP8527ESA

CHASSIS / ENGINE / PULLEYS

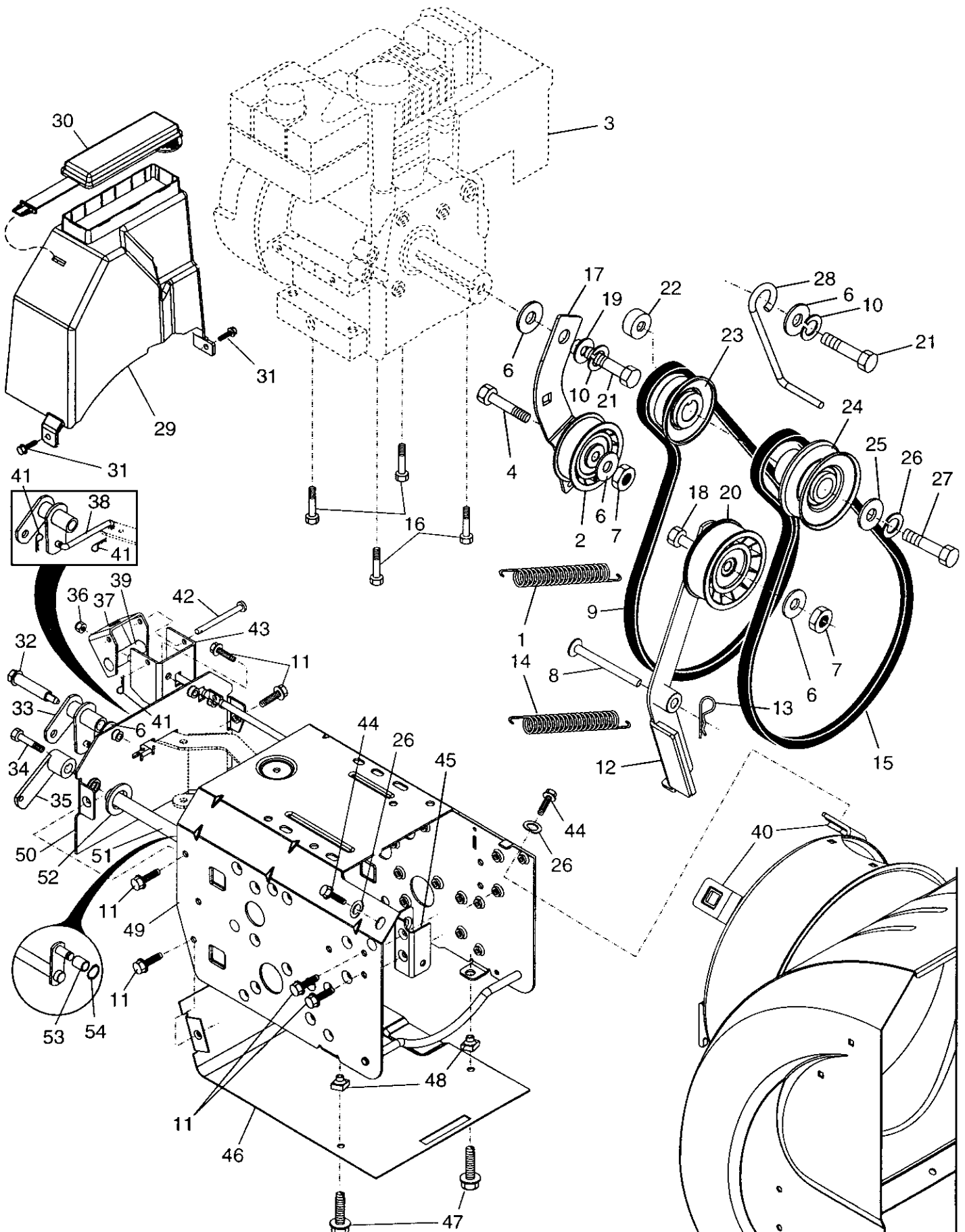

REPAIR PARTS**SNOW THROWER - MODEL NUMBER PP8527ESA****CHASSIS / ENGINE / PULLEYS**

KEY NO.	PART NO.	DESCRIPTION
1	181044	Spring, Traction Idler
2	180522	Pulley, Idler (2-1/4)
3	---	Engine, Tecumseh, Model Number HMSK85 (Order parts from Engine manufacturer)
4	74780520	Screw, Hex Head 5/16-18 x 1-1/4
6	59289	Washer, Flat
7	73930500	Nut, Jam, Lock 5/16-18
8	175330	Pin, Idler Pivot
9	179092	V-Belt, Traction Drive
10	10040500	Washer, Lock 5/16
11	17490508	Screw, Hex Head 5/16-18 x 3/4
12	179259	Impeller Idler Arm Assembly
13	85179	Retainer, Hairpin
14	178828	Spring, Brake
15	183533	V-Belt, Impeller Drive
16	150406	Screw, Hex Head 3/8-16 x 1-1/4
17	179354X008	Arm, Idler
18	74780524	Screw, Hex Head 5/16-18 x 1-1/2
19	175331	Bushing, Idler Pivot
20	180523	Pulley, Idler (2-3/4)
21	74610516	Screw, Hex Head 5/16-18 x 1
22	179371	Spacer, Engine Pulley
23	180478	Pulley, Engine, Traction Drive
24	179157	Pulley, Engine, Impeller Drive
25	62735	Washer, Flat 3/8
26	850263	Washer, Lock 3/8
27	851084	Screw, Hex Head 3/8-24 x 1-3/8
28	155452	Guide, Belt
29	180465	Cover, Belt
30	178830	Cover, Toolbox
31	17490408	Screw, Hex Head 1/4-20 x 1/2
32	179256	Bolt, Shoulder 5/16-18
33	187853	Bellcrank Shifter
34	180401	Screw, Hex Head 1/4-28 x 3/4
35	179240	Arm, Auger Control
36	73800500	Nut, Lock 5/16-18
37	178833X479	Bellcrank Assembly
38	187101	Link, Speed Control
39	179064	Trunnion, Pivot Bracket
40	178890	Nut, Cage 3/8-16
41	700279	Hairpin, Cotter 3/32 x 1/2
42	179065	Pin, Pivot Bracket
43	179063X479	Bracket, Bellcrank
44	74780624	Screw, Hex Head 3/8-16 x 1-1/2
45	175324X479	Pivot Bracket, Impeller Idler Arm
46	178624X479	Pan, Frame Bottom
47	71020512	Screw, Hex Head 5/16-18 x 3/4
48	181156	Nut, Speed 5/16-18
49	183852X428	Frame Assembly
50	187715X428	Plate, Frame End
51	179068X008	Shaft, Auger Control
52	57079	Washer, Hardened
53	179062	Roller
54	12000010	Ring, Retaining

NOTE: All component dimensions given in U.S. inches. 1 inch = 25.4 mm

REPAIR PARTS WHEELS / DECALS

SNOW THROWER - MODEL NUMBER PP8527ESA

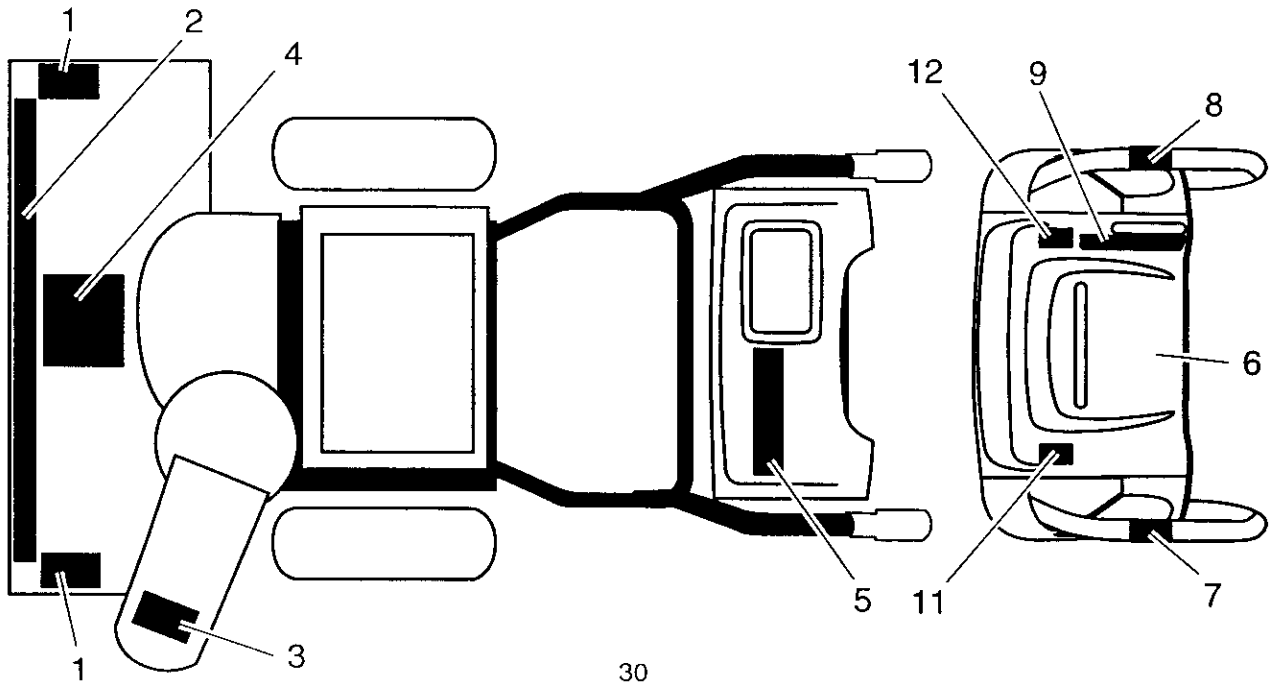
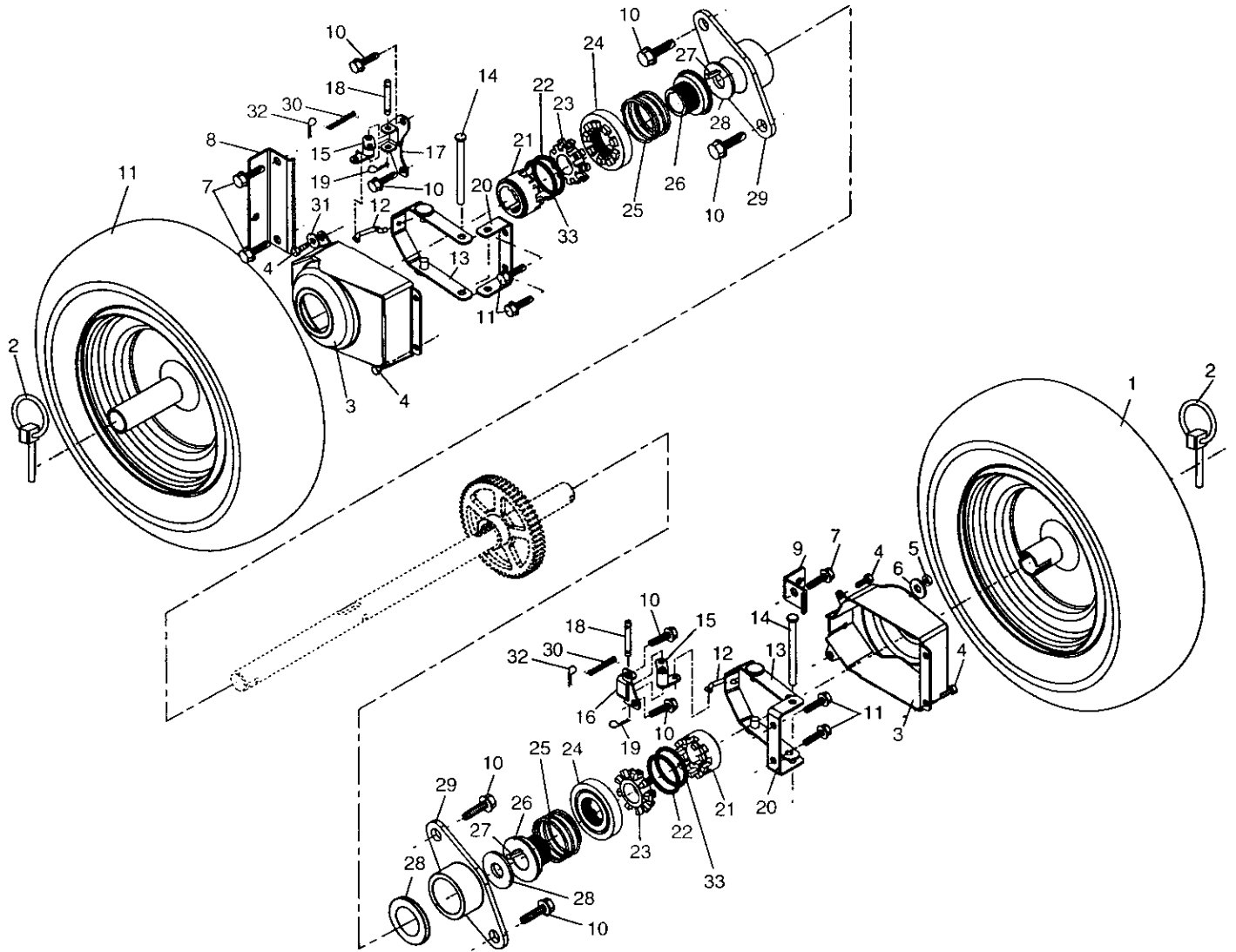

REPAIR PARTS
WHEELS / DECALS

SNOW THROWER - MODEL NUMBER PP8527ESA

KEY NO.	PART NO.	DESCRIPTION
1	187872	Wheel Assembly, 16", Power Steering, LH
2	155443	Pin, Klik 1/4
3	181843	Cover, Power Steering
4	184471	Screw, Hex Head #10-24 x 1/2
5	73800500	Nut, Lock 5/16-18
6	155415	Washer, Flat 5/16
7	71210616	Screw, Hex Head 3/8-16 x 1
8	185603X479	Bracket, Steer Cable RH
9	185602X479	Bracket, Steer Cable LH
10	146315	Screw, Hex Head 5/16-18 x 3/4
11	187874	Wheel Assembly, 16", Power Steering, RH
12	184393	Link, Steering Lever
13	185403X479	Lever Assembly, Steering
14	182015	Pin, Steering Lever
15	184361	Bellcrank Assembly
16	181982	Bracket Assembly, LH Steering
17	182063	Bracket Assembly, RH Steering
18	181847	Pin, Steering Bellcrank
19	85179	Retainer, Hairpin
20	179148X479	Bracket, Lever Assembly
21	179141	Driver, Wheel
22	182466	Ring, Wire Retainer
23	179136	Lobe, Wheel
24	179138	Slide, Clutch
25	179139	Spring, Clutch Slide
26	179137	Lobe, Axle
27	178879	Key, Square 1/4
28	174697	Washer, Thrust (1")
29	179830	Bearing, Axle
30	184453	Spring, Return
32	700279	Clip, Retainer
33	12000045	Ring, Retaining

KEY NO.	PART NO.	DESCRIPTION
1	181037	Decal, Danger
2	183886	Decal, Poulan Pro, 8.5HP/27" (Large)
3	181035	Decal, Danger, Deflector
4	181042	Decal, Danger
5	187870	Decal, Poulan Pro, 8.5HP/27" (Small)
6	181033	Decal, Instruction
7	155798	Decal, Traction Lever
8	155800	Decal, Auger Lever
9	181039	Decal, Speed Control
11	183907	Decal, LH Trigger
12	183905	Decal, RH Trigger
--	187877	Owner's Manual (English)
--	187888	Owner's Manual (French)

NOTE: All component dimensions given in U.S. inches
1 inch = 25.4 mm

LIMITED WARRANTY

The Manufacturer warrants to the original consumer purchaser that this product as manufactured is free from defects in materials and workmanship. For a period of two (2) years from date of purchase by the original consumer purchaser, we will repair or replace, at our option, without charge for parts or labor incurred in replacing parts, any part which we find to be defective due to materials or workmanship. This Warranty is subject to the following limitations and exclusions.

1. This warranty does not apply to the engine or components parts thereof. Please refer to the applicable manufacturer's warranty on these items.
2. Transportation charges for the movement of any power equipment unit or attachment are the responsibility of the purchaser. Transportation charges for any parts submitted for replacement under this warranty must be paid by the purchaser unless such return is requested by Electrolux Home Products.
3. The Warranty period for any products used for rental or commercial purposes is limited to 90 days from the date of original purchase.
4. This Warranty applies only to products which have been properly assembled, adjusted, operated, and maintained in accordance with the instructions furnished. This Warranty does not apply to any product which has been subjected to alteration, misuse, abuse, improper assembly or installation, delivery damage, or to normal wear of the product.
5. Exclusions: Excluded from this Warranty are belts, shear pins, normal wear, normal adjustments, standard hardware and normal maintenance.
6. In the event you have a claim under this Warranty, you must return the product to an authorized service dealer.

Should you have any unanswered questions concerning this Warranty, please contact:

In Canada contact:

Electrolux Canada Corp.
7075 Ordan Drive
Mississauga, Ontario
L5T 1K6

Electrolux Home Products, Inc.

Outdoor Products Customer Service Dept.
250 Bobby Jones Expressway
Augusta, GA 30909 USA

giving the complete mfg. ID#, serial number and date of purchase of your product and the name and address of the authorized dealer from whom it was purchased.

THIS WARRANTY DOES NOT APPLY TO INCIDENTAL OR CONSEQUENTIAL DAMAGES AND ANY IMPLIED WARRANTIES ARE LIMITED TO THE SAME TIME PERIODS STATED HEREIN FOR OUR EXPRESSED WARRANTIES. Some areas do not allow the limitation of consequential damages or limitations of how long an implied Warranty may last, so the above limitations or exclusions may not apply to you. This Warranty gives you specific legal rights, and you may have other rights which vary from locale to locale.

This is a limited Warranty within the meaning of that term as defined in the Magnuson-Moss Act of 1975.

Poulan PRO