

RYOBI®

875r

4-Cycle Gas Trimmer

OPERATOR'S MANUAL



FOR QUESTIONS, CALL 1-800-345-8746 in U.S. or
1-800-265-6778 in CANADA
www.ryobi.com

IMPORTANT MANUAL

DO NOT THROW AWAY

INTRODUCTION

THANK YOU

Thank you for buying this quality product. This modern outdoor power tool will provide many hours of useful service. You will find it to be a great labor-saving device. This operator's manual provides you with easy-to-understand operating instructions. Read the whole manual and follow all the instructions to keep your new outdoor power tool in top operating condition. The other manual that came with your power tool, the parts manual, contains all the information that you need to order parts.

PRODUCT REFERENCES, ILLUSTRATIONS AND SPECIFICATIONS

All information, illustrations and specifications in this manual are based on the latest product information available at the time of printing. We reserve the right to make changes at any time without notice.

Copyright© 1998 Ryobi Outdoor Products, Inc.
All Rights Reserved.

Click-Link® is a registered trademark of Ryobi Outdoor Products.

SpeedSpool® is a registered trademark of Ryobi Outdoor Products.

SERVICE INFORMATION

Service on this unit both within and after the warranty period should be performed only by an authorized and approved service dealer.

Dial:

• **1-800-345-8746** or **www.ryobi.com** on the world wide web for authorized service dealers in the United States

Or

• **1-800-265-6778** in Canada to obtain the listing of the authorized service dealer nearest you.

to obtain the listing of the authorized service dealer nearest you.

DO NOT RETURN THE UNIT TO THE RETAILER.

NOTE: PROOF OF PURCHASE WILL BE REQUIRED FOR WARRANTY SERVICE.

Make sure this manual is carefully read and understood before starting or operating this equipment.

THIS PRODUCT IS COVERED BY ONE OR MORE US PATENTS, OTHER PATENTS PENDING.

TABLE OF CONTENTS

I. California Emission Regulations	3
II. Rules for Safe Operation	4-8
A. Important Safety Information	4-5
B. Safety and International Symbols	6-7
C. Know Your Unit	8
III. Assembly Instructions	9
A. Adjusting the J handle	9
IV. Oil and Fuel Information	10-11
A. Recommended Oil Type	10
B. Adding Oil to Crankcase-Initial Use	10
C. Recommended Fuel Type	11
D. Fueling the Unit	11
V. Starting/Stopping Instructions	12
VI. Operating Instructions	13-15
A. Operating the Click-Link System	13
B. Holding the Trimmer	14
C. Adjusting Trimming Line Length	14
D. Tips for Best Trimming Results	14
E. Decorative Trimming	15
VII. Maintenance and Repair Instructions	15-24
A. Maintenance Schedule	15
B. Line Installation for the SpeedSpool	16
C. Installing a Prewound Reel	17
D. Cleaning the SpeedSpool	18
E. SpeedSpool Replacement Parts	18
F. Checking the Oil Level	19
G. Changing the Oil	19
H. Air Filter Maintenance	20
I. Carburetor Adjustment	21
J. Rocker Arm Clearance	22
K. Replacing the Spark Plug	24
L. Spark Arrestor Maintenance	24
M. Accessories/Replacement parts	24
VIII. Cleaning and Storage	25
IX. Troubleshooting Chart	26
X. Specifications	27
XI. Warranty	29-30

CONTENTS OF CARTON

This carton should include of the following:

- Model 875r Trimmer with J-Handle
- Operator's Manual
- Parts Manual
- Product Registration Card
- Bottle of 4-Cycle Oil

CALIFORNIA EMISSION REGULATIONS

This engine meets U.S. EPA PH1 and 2000 model year and later California emissions regulations for small off-road engines. These units are identified by the label on the engine of your product. A typical identification label is shown.

To ensure that your unit continues to meet these regulations, refer to the following information and instructions in this operator's manual.

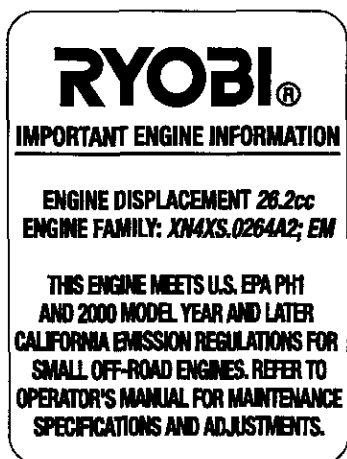

California Proposition 65 Warning:

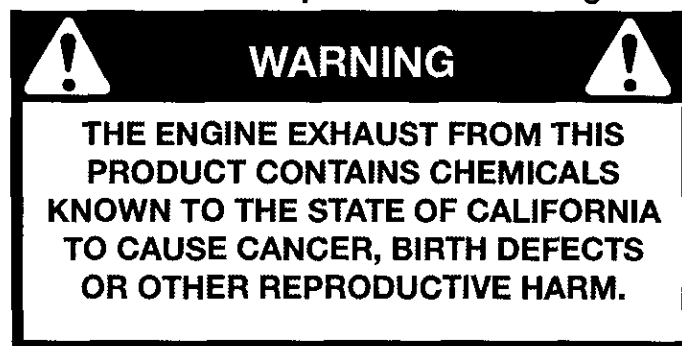

SPARK ARRESTOR

NOTE: For users on U.S. Forest Land and in the states of California, Maine, Oregon and Washington. All U.S. Forest Land and the state of California (Public Resources Codes 4442 and 4443), Oregon and Washington require, by law that certain internal combustion engines operated on forest brush and/or grass-covered areas be equipped with a spark arrestor, maintained in effective working order, or the engine be constructed, equipped and maintained for the prevention of fire. Check with your state or local authorities for regulations pertaining to these requirements. Failure to follow these requirements could subject you to liability or a fine. **This unit is factory equipped with a spark arrestor.** If it requires replacement, ask your LOCAL SERVICE dealer to install the Accessory Part #180890 Spark Arrestor Screen.

FOR QUESTIONS, CALL 1-800-345-8746 IN U.S. OR 1-800-265-6778 in CANADA

WARNING!

Read the Operator's Manual(s) and follow all warnings and safety instructions. Failure to do so can result in serious injury to the operator and/or bystanders.

RULES FOR SAFE OPERATION

The purpose of safety symbols is to attract your attention to possible dangers. The safety symbols, and their explanations, deserve your careful attention and understanding. The safety warnings do not by themselves eliminate any danger. The instructions or warnings they give are not substitutes for proper accident prevention measures.

SYMBOL	MEANING
	SAFETY ALERT SYMBOL: Indicates danger, warning, or caution. Attention is required in order to avoid serious personal injury. May be used in conjunction with other symbols or pictographs.
NOTE: Advises you of information or instructions vital to the operation or maintenance of the equipment.	



DANGER: Failure to obey a safety warning will result in serious injury to yourself or to others. Always follow the safety precautions to reduce the risk of fire, electric shock, and personal injury.



WARNING: Failure to obey a safety warning can result in injury to yourself and others. Always follow the safety precautions to reduce the risk of fire, electric shock, and personal injury.



CAUTION: Failure to obey a safety warning may result in property damage or personal injury to yourself or to others. Always follow the safety precautions to reduce the risk of fire, electric shock, and personal injury.

• IMPORTANT SAFETY INFORMATION •

READ ALL INSTRUCTIONS

BEFORE OPERATING

- Read the instructions carefully. Be familiar with the controls and proper use of the unit.
- Do not operate this unit when tired, ill, or under the influence of alcohol, drugs, or medication.
- Children and teens under the age of 15 must not use the unit, except for teens guided by an adult.
- Inspect the unit before use. Replace damaged parts. Check for fuel leaks. Make sure all fasteners are in place and secure. Replace cutting attachment parts that are cracked, chipped, or damaged in any way. Make sure the cutting attachment is properly installed and securely fastened. Be sure the cutting attachment shield is properly attached, and positioned as recommended. Failure to do so can result in personal injury to the operator and bystanders, as well as damage to the unit.
- Use only 0.080 inch (2.03 mm) diameter genuine Ryobi replacement line. Never use metal-reinforced line, wire, or rope, etc.. These can break off and become a dangerous projectile.
- Be aware of the risk of injury to the head, hands and feet.
- Clear the area to be cut before each use. Remove all objects such as rocks, broken glass, nails, wire, or string which can be thrown or become entangled in the cutting attachment. Clear the area of children, bystanders, and pets. At a minimum, keep all children, bystanders and pets outside a 50 feet (15 m.) radius; there still may be a risk to bystanders from thrown objects. Bystanders should be encouraged to wear eye protection. If you are approached, stop the engine and cutting attachment immediately.

- Squeeze the throttle control and check that it returns automatically to the idle position. Make all adjustments or repairs before using unit.

- This unit was not designed to be used as a brushcutter. Do not attach or operate this unit with any type of brushcutting blade or brushcutting attachment.

SAFETY WARNINGS FOR GAS TRIMMERS

WARNING: Gasoline is highly flammable, and its vapors can explode if ignited. Take the following precautions:

- Store fuel only in containers specifically designed and approved for the storage of such materials.
- Always stop the engine and allow it to cool before filling the fuel tank. Never remove the cap of the fuel tank, or add fuel, when the engine is hot. Never operate the unit without the fuel cap securely in place. Loosen the fuel tank cap slowly to relieve any pressure in the tank.
- Add fuel in a clean, well-ventilated area outdoors where there are no sparks or flames. Slowly remove the fuel cap only after stopping engine. Do not smoke while fueling or mixing fuel. Wipe up any spilled fuel from the unit immediately.
- Avoid creating a source of ignition for spilled fuel. Do not start the engine until fuel vapors dissipate.
- Move the unit at least 30 feet (9.1 m) from the fueling source and site before starting the engine. Do not smoke, keep sparks and open flames from the area while adding fuel or operating the unit.

RULES FOR SAFE OPERATION

WHILE OPERATING

- Never start or run the unit inside a closed room or building. Breathing exhaust fumes can kill. Operate this unit only in a well ventilated area outdoors.
- Wear safety glasses or goggles that are marked as meeting ANSI Z87.1-1989 standards, and ear/hearing protection when operating this unit. Wear a face or dust mask if the operation is dusty. Long sleeve shirts are recommended.
- Wear heavy, long pants, boots and gloves. Do not wear loose clothing, jewelry, short pants, sandals or go barefoot. Secure hair above shoulder level.
- The cutting attachment shield must always be in place while operating the unit. Do not operate unit without both trimming lines extended, and the proper line installed. Do not extend the trimming line beyond the length of the shield.
- This unit has a clutch. The cutting attachment remains stationary when the engine is idling. If it does not, have the unit adjusted by an authorized service technician.
- Adjust the J-Handle to your size to provide the best grip.
- Be sure the cutting attachment is not in contact with anything before starting the unit.
- Use the unit only in daylight or good artificial light.
- Avoid accidental starting. Be in the starting position whenever pulling the starter rope. The operator and unit must be in a stable position while starting. See Starting/Stopping Instructions.
- Use the right tool. Only use this tool for the purpose intended.
- Do not overreach. Always keep proper footing and balance.
- Always hold the unit with both hands when operating. Keep a firm grip on both the front and rear handle or grips.
- Keep hands, face, and feet at a distance from all moving parts. Do not touch or try to stop the cutting attachment when it is rotating.
- Do not touch the engine or muffler. These parts get extremely hot from operation. When turned off they remain hot for a short time.
- Do not operate the engine faster than the speed needed to cut, trim or edge. Do not run the engine at high speed when not cutting.
- Always stop the engine when cutting is delayed or when walking from one cutting location to another.
- If you strike or become entangled with a foreign object, stop the engine immediately and check for damage. Do not operate before repairing damage. Do not operate the unit with loose or damaged parts.
- Stop and switch the engine to off for maintenance, repair, or for changing the cutting attachment or other attachments.
- Use only genuine Ryobi replacement parts when servicing this unit. These parts are available from your authorized service dealer. Do not use parts, accessories or attachments not authorized by Ryobi for this unit. Doing so could lead to serious injury to the user, or damage to the unit, and void your warranty.
- Keep unit clean of vegetation and other materials. They may become lodged between the cutting attachment and shield.
- To reduce fire hazard, replace faulty muffler and spark arrestor, keep the engine and muffler free from grass, leaves, excessive grease or carbon build up.

OTHER SAFETY WARNINGS

- Never store the unit, with fuel in the tank, inside a building where fumes may reach an open flame or spark.
- Allow the engine to cool before storing or transporting. Be sure to secure the unit while transporting.
- Store the unit in a dry area, locked up or up high to prevent unauthorized use or damage, out of the reach of children.
- Never douse or squirt the unit with water or any other liquid. Keep handles dry, clean and free from debris. Clean after each use, see **Cleaning and Storage** instructions.
- Keep these instructions. Refer to them often and use them to instruct other users. If you loan someone this unit, also loan them these instructions.

SAVE THESE INSTRUCTIONS

RULES FOR SAFE OPERATION

SAFETY AND INTERNATIONAL SYMBOLS

This operator's manual describes safety and international symbols and pictographs that may appear on this product. Read the operator's manual for complete safety, assembly, operating and maintenance and repair information.

SYMBOL

MEANING



- **SAFETY ALERT SYMBOL**

Indicates danger, warning, or caution. May be used in conjunction with other symbols or pictographs.



- **WARNING - READ OPERATOR'S MANUAL**

Read the Operator's Manual(s) and follow all warnings and safety instructions. Failure to do so can result in serious injury to the operator and/or bystanders.



- **FOR SERVICE INFORMATION, CALL:**

USA: 1-800-345-8746

CANADA: 1-800-265-6778



- **WEAR EYE AND HEARING PROTECTION**

WARNING: Thrown objects and loud noise can cause severe eye injury and hearing loss. Wear eye protection meeting ANSI Z87.1-1989 standards and ear protection when operating this unit.



- **KEEP BYSTANDERS AWAY**

WARNING: Keep all bystanders, especially children and pets, at least 50 feet (15 m.) from the operating area.



- **PRIMER BULB**

Push primer bulb, fully and slowly, 5 to 7 times.



- **UNLEADED FUEL**

Always use clean, fresh unleaded fuel.



- **OIL**

Refer to operator's manual for the proper type of oil.

RULES FOR SAFE OPERATION

SYMBOL

MEANING



- **THROWN OBJECTS AND ROTATING CUTTER CAN CAUSE SEVERE INJURY**

WARNING: Do not operate without the cutting attachment shield in place. Keep away from the rotating cutting attachment.



- **ON/OFF STOP CONTROL**

ON / START / RUN



- **ON/OFF STOP CONTROL**

OFF OR STOP



- **HOT SURFACE WARNING**

Do not touch a hot muffler or cylinder. You may get burned. These parts get extremely hot from operation. When turned off they remain hot for a short time.



- **SHARP BLADE**

WARNING: Sharp blade on cutting attachment shield. To prevent serious injury, do not touch line cutting blade.



- **CHOKE CONTROL**

A • **FULL** choke position.
B • **PARTIAL** choke position.
C • **RUN** position.



WARNING: The operation of any power tool can cause foreign objects to be thrown into your eyes. This can lead to severe eye damage. Before commencing power tool operation, always wear safety glasses or goggles that are marked as meeting ANSI Z87.1-1989 standards, and a full face shield when needed.

RULES FOR SAFE OPERATION

KNOW YOUR UNIT

APPLICATIONS

As a trimmer;

- Cutting grass and light weeds.
- Edging
- Decorative trimming around trees, fences, etc.

Other optional accessories may be used with the 875r.
See list of add-ons on page 13.

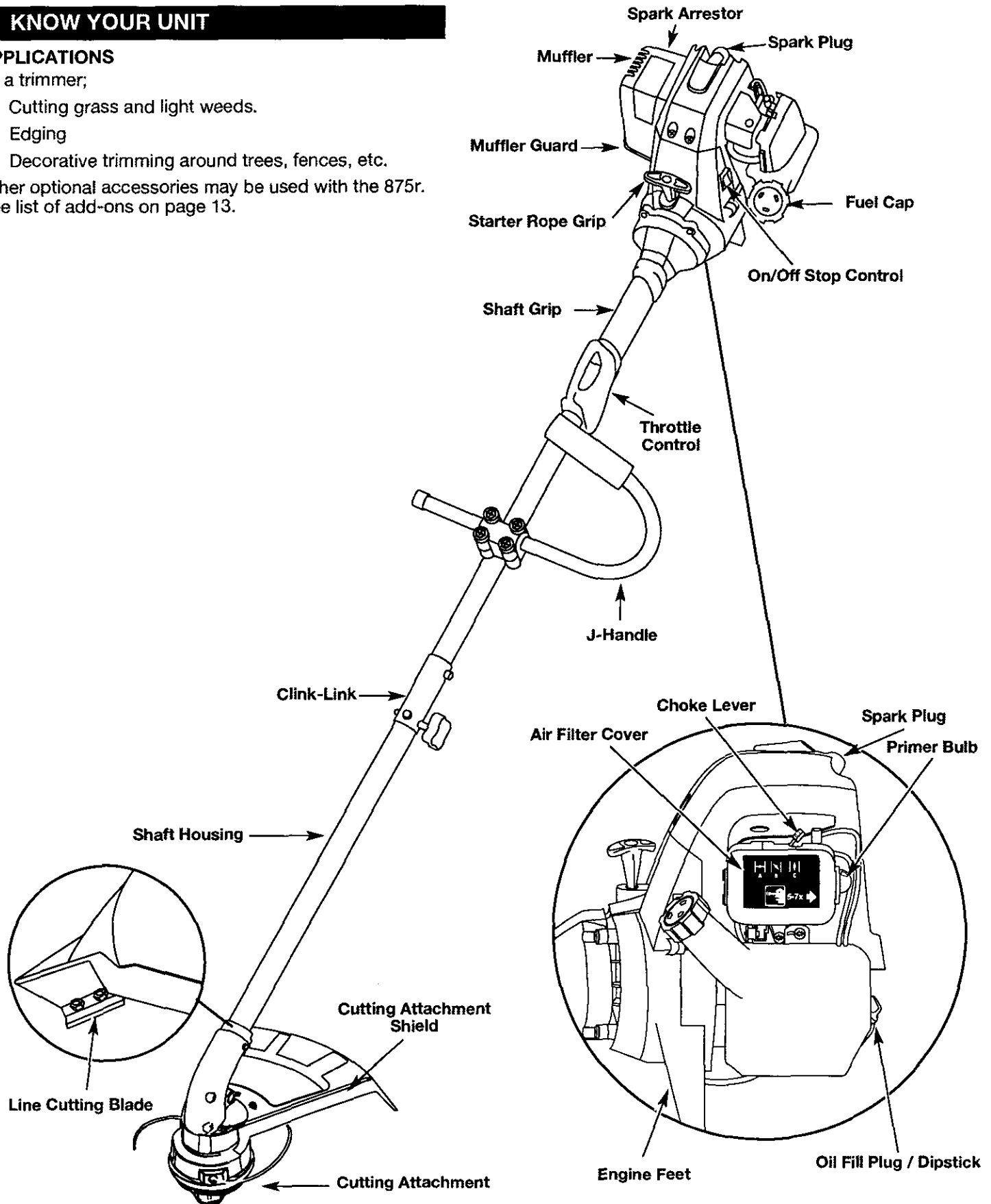

ASSEMBLY INSTRUCTIONS

ADJUSTING THE J-HANDLE

1. Loosen the four (4) screws holding the J-handle in place (Fig. 1). Do not completely remove the screws.

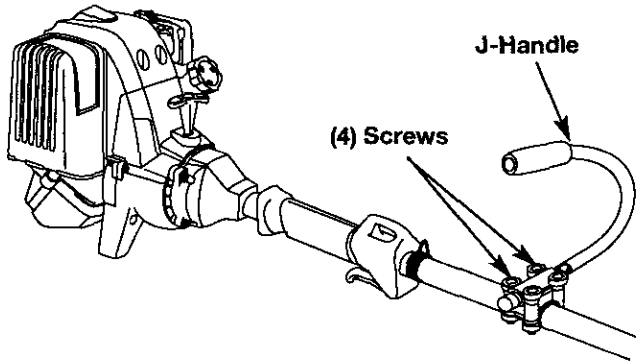

Fig. 1

2. Slide the J-handle in or out until the arrow/white line on the decal touches the clamp assembly (Fig. 2).

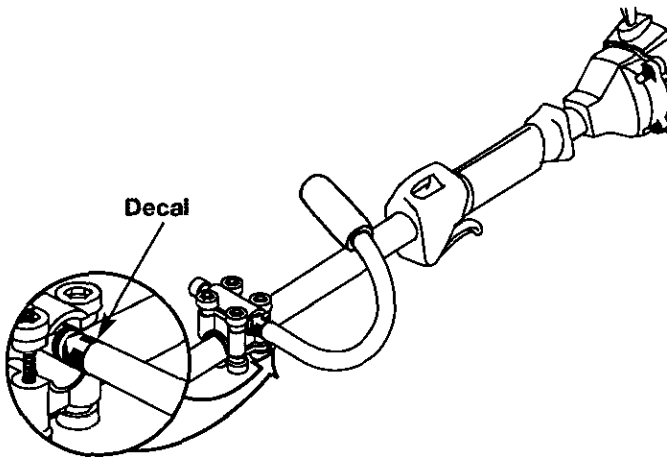

Fig. 2

3. While holding the unit in the operating position (Fig. 3), position the J-handle to the location that provides you the best grip.

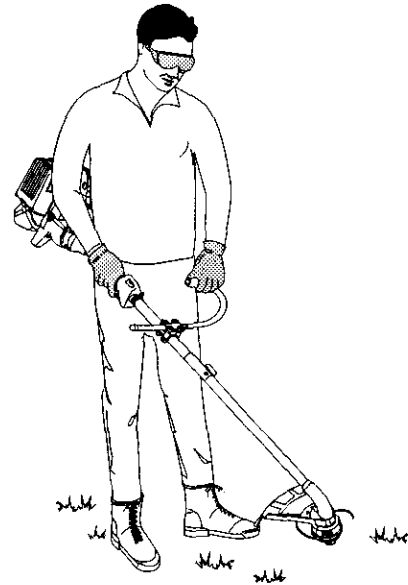

Fig. 3

4. Tighten the clamp screws evenly, until the J-handle is secure.

OIL AND FUEL INFORMATION

RECOMMENDED OIL TYPE

Using the proper type and weight of oil in the crankcase is extremely important. Check the oil before each use and change the oil regularly. Failure to use the correct oil, or using dirty oil, can cause premature engine wear and failure.

Use a high-quality SAE 30 weight oil of API (American Petroleum Institute) service class SF, SG, SH.

ADDING OIL TO CRANKCASE – INITIAL USE

NOTE: This unit is shipped without being filled with oil. In order to avoid damage to the unit, put oil in the crankcase before attempting to start unit.

Your unit is supplied with one 3.4 fluid oz. (100 ml.) bottle of SAE 30 SF, SG, SH oil (Fig. 4).

NOTE: Save the bottle to measure the correct amount for future oil changes. See **Changing the Oil** Pg. 19.

1. Unscrew the top of the bottle of oil and remove the paper seal covering the opening. Replace top. Cut the tip off the funnel spout (Fig. 4).

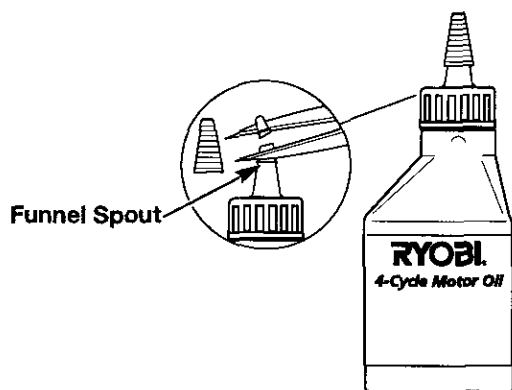

Fig. 4

2. Place the unit on a flat level surface.
3. Remove the oil plug / dipstick from the crankcase (Fig. 5).

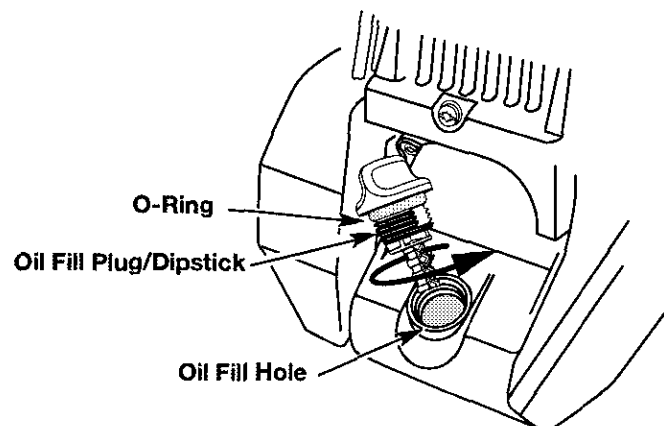

Fig. 5

4. Pour the entire bottle of oil into the oil fill hole (Fig. 6).

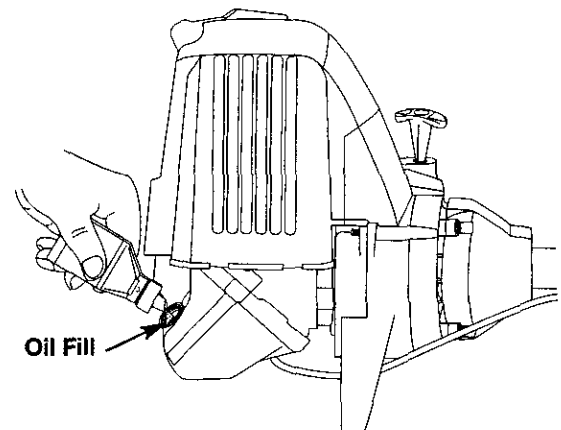

Fig. 6

NOTE: Never add oil to the fuel or fuel tank.

5. Wipe up any oil that may have spilled and reinstall the oil fill plug / dipstick.

The importance of checking and maintaining the proper oil level in the crankcase cannot be overemphasized. Check oil before each use and change as needed. See **Changing the Oil** Pg. 19.

OIL AND FUEL INFORMATION

RECOMMENDED FUEL TYPE



Old fuel is the primary reason for the unit not running properly. Be sure to use fresh, clean, unleaded Gasoline.

NOTE: This is a four cycle engine. In order to avoid damage to the unit, **do not mix oil with Gasoline.**

Definition of Blended Fuels

Today's fuels are often a blend of gasoline and oxygenates such as ethanol, methanol or MTBE (ether). Alcohol-blended fuel absorbs water. As little as 1% water in the fuel can make fuel and oil separate or form acids when stored. Use fresh fuel (less than 60 days old), when using alcohol-blended fuel.

Using Blended Fuels

If you choose to use a blended fuel, or its use is unavoidable, follow recommended precautions.

- Always use fresh unleaded gasoline
- Use the fuel additive STA-BIL® or an equivalent.
- Drain tank and run the engine dry before storing unit.

Using Fuel Additives

The use of fuel additives, such as STA-BIL® Gas Stabilizer or an equivalent, will inhibit corrosion and minimize the formation of gum deposits. Using a fuel additive can keep fuel from forming harmful deposits in the carburetor for up to six (6) months. Add 0.8 oz. (23 ml.) of fuel additive per gallon of fuel according to the instructions on the container. **NEVER** add fuel additives directly to the unit's gas tank.

FUELING UNIT



WARNING: Gasoline is extremely flammable and its vapors can explode if ignited. To avoid serious personal injury, always stop the engine and allow it to cool before filling the fuel tank. Do not smoke while filling the tank. Keep sparks and open flames away from the area.

1. Remove fuel cap (Fig. 7).



WARNING: Remove fuel cap slowly to avoid injury from gasoline spray.

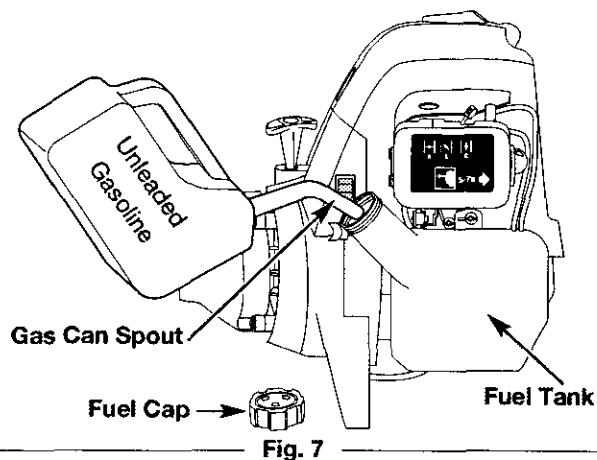

2. Place spout of gas container into the fill hole on the fuel tank (Fig. 7) and fill tank.



WARNING: Add gasoline in a clean, well ventilated area outdoors. Avoid creating a source of ignition for spilled fuel.

NOTE: Do not overfill tank.

3. Wipe up any gasoline that may have spilled
4. Reinstall the fuel cap.



WARNING: Never operate the unit without the fuel cap securely in place.

5. Move the unit at least 30 ft. (9.1 m) from the fueling source and site before starting the engine.

NOTE: Dispose of the old gasoline in accordance to Federal, State, and Local regulations.

STARTING/STOPPING INSTRUCTIONS

STARTING INSTRUCTIONS

Cold Start - First Start of the Day or Engine Ran Out of Fuel



WARNING: Operate this unit only in a well ventilated area outdoors. Carbon monoxide exhaust fumes can be lethal in a confined area.

1. Check oil level in crankcase. See **Checking the Oil Level** Pg. 19.
2. Fill the fuel tank with fresh, clean, unleaded gasoline (see page 11).
3. Put the Start/Stop Engine Control in the **START [I]** position (Fig. 8).

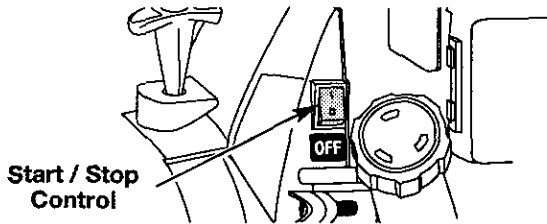

Fig. 8

4. Place the choke lever in the **FULL choke (A) |←|** position (Fig. 9).

NOTE: Slide the choke lever directly above the appropriate symbol on air filter cover decal (Fig. 9).

5. Fully press and release the primer bulb slowly 7 times. Gasoline should be felt and visible in the bulb (Fig. 9). If gasoline has not entered the bulb, press three more times, or until it does.

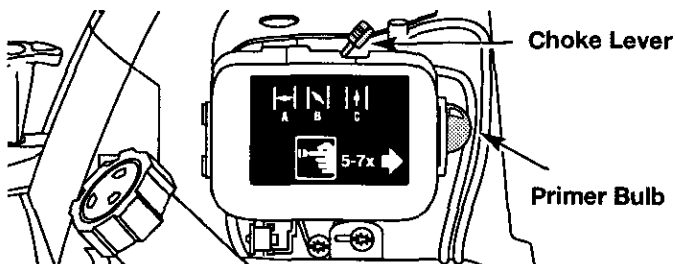

Fig. 9

6. Squeeze the throttle control to the wide open (full throttle) position.
7. With the unit in the starting position (Fig. 10) pull the starter rope briskly 5 times in the **FULL choke (A) |←|** position. If the engine attempts to run before the fifth pull, proceed to step 8.
8. Move the choke lever to the **PARTIAL (B) |↘|** position (Fig. 9).

NOTE: The engine will not run in the **FULL choke (A) |←|** position.

9. Pull the starter rope 1 to 3 pulls until the engine starts. Run for 15-30 seconds. If the unit fails to start return to step 7.
10. Move the choke lever to the **RUN (C) |→|** position and run at full throttle for 30 seconds.



WARNING: Avoid accidental starting. Be in the starting position whenever pulling the starting rope. To avoid serious personal injury, the operator and unit must be in a stable position while starting.

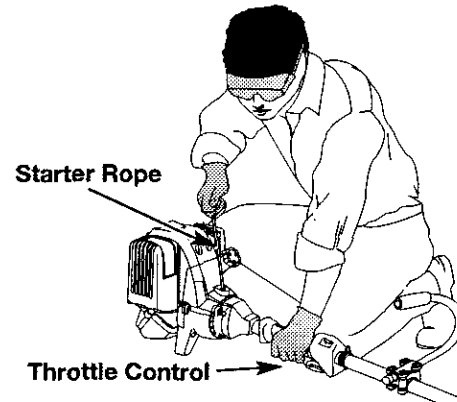

Fig. 10

11. Release the throttle control to the idle position and begin operation.

NOTE: If the engine does not start using these procedures, repeat steps 5 through 11 using **TWO (2)** pulls in the **FULL choke (A) |←|** position.

Engine Re-Start - Warm Engine With Fuel

1. Put the Start/Stop Engine Control in the **START [I]** position (Fig. 8).
2. Move the choke lever to the **PARTIAL (B) |↘|** position (Fig. 9).
3. Fully press and release the primer bulb slowly 7 times. Gasoline should be felt and visible in the bulb (Fig. 9). If gasoline has not entered the bulb, press three more times, or until it does.
4. Squeeze the throttle control to the wide open (full throttle) position.
5. With the unit in the starting position (Fig. 10), pull the starter rope briskly until the engine starts.
6. When the engine starts, move the choke lever to the **RUN (C) |→|** position, and run at full throttle for 30 seconds.

NOTE: If the engine does not start using the **Engine Re-start** procedures, revert to the **Cold Start** procedures.

NOTE: 4-stroke engines, like cars, are able to start in the idle position. As an alternate method, you may want to start your unit in the idle position when the unit is warm. With the Start/Stop control in the **START** position, pull the starter rope briskly. When the engine starts, run at full throttle for 30 seconds. If the unit fails to start or dies, revert to the **Engine Re-Start** procedure.

STOPPING INSTRUCTIONS

1. Release your hand from the throttle control (Fig. 10). Allow the engine to idle.
2. To stop the engine, put the Start/Stop Engine Control in the **STOP [O]** position (Fig. 8).

OPERATING INSTRUCTIONS

OPERATING THE CLICK-LINK® SYSTEM

The Click-Link® system enables the use of these optional add-ons.

Blower/Vacuum	BV720r
Cultivator	GC720r
Edger	LE720r
Hedge Trimmer	HS720r
Snow Thrower	ST720r
Straight Shaft Trimmer	SS725r
Sweeper/Blower	SB720r
Tree Pruner	TP720r
Turbo Blower	TB720r



WARNING: Read and understand operator's manual for add-on prior to operation.

Removing the Cutting Attachment or Add-Ons:

1. Turn the knob counterclockwise to loosen (Fig. 11).
2. Press and hold the release button (Fig. 11).
3. While firmly holding the upper shaft housing, pull the cutting attachment or add-on straight out of the Click-Link® coupler (Fig. 12).

Installing the Cutting Attachment or Add-Ons:



WARNING: To avoid serious personal injury and damage to the unit, shut unit off before removing or installing add-ons.

NOTE: To make installing or removing the add-on easier, place the unit on the ground or on a work bench.

1. Turn knob counterclockwise to loosen (Fig. 11).

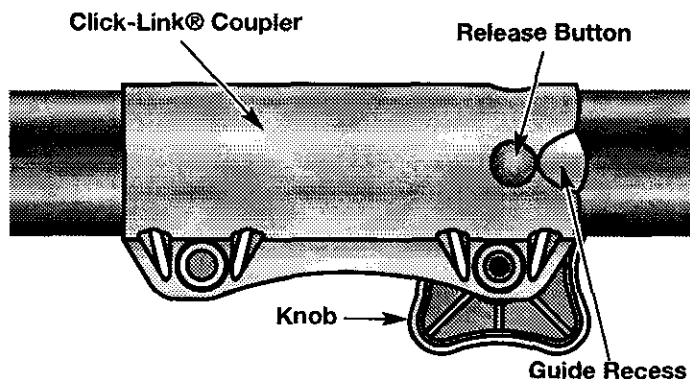

Fig. 11

2. While firmly holding the add-on, push it straight into the Click-Link® coupler (Fig. 12).

NOTE: Aligning the release button with the guide recess will help installation (Fig. 11).

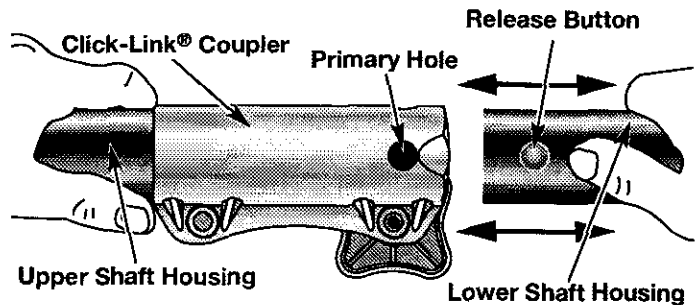

Fig. 12

3. Turn the knob clockwise to tighten (Fig. 13).



CAUTION: Lock the release button in the primary hole and securely tighten the knob before operating this unit.

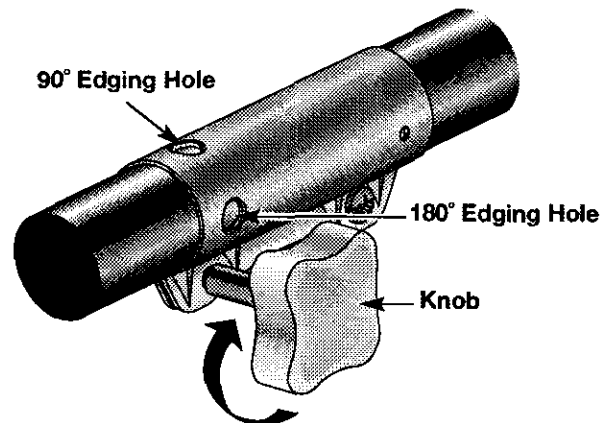

Fig. 13



CAUTION: The cutting attachment and add-ons with the Click-Link® system are to be used in the primary hole unless stated otherwise in the specific add-ons operator's manual. Using the wrong hole could lead to personal injury, or damage to the unit.

For edging when using the line head cutting attachment with Click-Link® models, lock the release button of the cutting attachment into the 90° edging hole or the 180° edging hole (Fig. 12).

OPERATING INSTRUCTIONS

HOLDING THE TRIMMER



WARNING: Always wear eye, hearing, foot and body protection to reduce the risk of injury when operating this unit.

Before operating the unit, stand in the operating position (Fig. 14). Check for the following:

- The operator is wearing eye protection and proper clothing.
- The right arm is slightly bent, and the hand is holding the shaft grip.
- The left arm is straight, and the hand is holding the J-handle.



Fig. 14

- The unit is at waist level.
- The sweeper/blower is parallel to the ground and is positioned so debris is blown away from operator.

ADJUSTING TRIMMING LINE LENGTH

The Bump Head™ cutting attachment allows you to release trimming line without stopping the engine. To release more line, lightly tap the cutting attachment on the ground (Fig. 15) while operating the trimmer at high speed.

NOTE: Always keep the trimming line fully extended. Line release becomes more difficult as cutting line becomes shorter

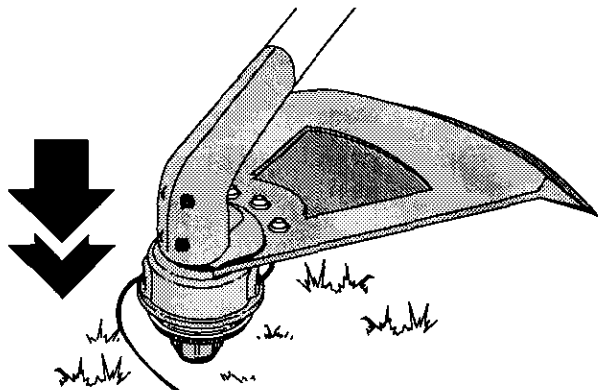

Fig. 15

Each time the head is bumped, about 1 inch (25.4 mm.) of trimming line is released. A blade in the cutting attachment shield will cut the line to the proper length if excess line is released.

For best results, tap the Bump Head™ on bare ground or hard soil. If line release is attempted in tall grass, the engine may stall. Always keep the trimming line fully extended. Line release becomes more difficult as the cutting line becomes shorter.

NOTE: Do not rest the Bump Head™ on the ground while the unit is running .



CAUTION: Do not remove or alter the line cutting blade assembly. Excessive line length will make the clutch overheat. This may lead to serious personal injury or damage to the unit.

Some line breakage will occur from:

- Entanglement with foreign matter
- Normal line fatigue
- Attempting to cut thick, stalky weeds
- Forcing the line into objects such as walls or fence posts

TIPS FOR BEST TRIMMING RESULTS

- Keep the cutting attachment parallel to the ground.
- Do not force the cutting attachment. Allow the tip of the line to do the cutting, especially along walls. Cutting with more than the tip will reduce cutting efficiency and may overload the engine.
- Cut grass over 8 inches (200 mm) by working from top to bottom in small increments to avoid premature line wear or engine drag.
- Cut from left to right whenever possible. Cutting to the right improves the unit's cutting efficiency. Clippings are thrown away from the operator.
- Slowly move the trimmer into and out of the cutting area at the desired height. Move either in a forward-backward or side-to-side motion. Cutting shorter lengths produces the best results.
- Trim only when grass and weeds are dry.
- The life of your cutting line is dependent upon;
 - Following the previous trimming techniques
 - What vegetation is being cut
 - Where it's being cut

For example, the line will wear faster when trimming against a foundation wall as opposed to trimming around a tree.

OPERATING INSTRUCTIONS

DECORATIVE TRIMMING

Decorative trimming is accomplished by removing all vegetation around trees, posts, fences, etc.

Rotate the whole unit so that the cutting attachment is at a 30° angle to the ground (Fig. 16).

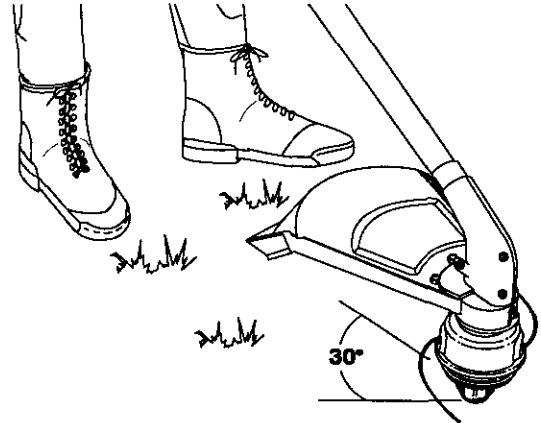

Fig. 16

MAINTENANCE AND REPAIR INSTRUCTIONS

NOTE: Some maintenance procedures may require special tools or skills. If you are unsure about these procedures take your unit to an authorized service dealer.

MAINTENANCE SCHEDULE

These required maintenance procedures should be performed at the frequency stated in the table. They should also be included as part of any seasonal tune-up.



WARNING: To prevent serious injury, never do maintenance or repairs with unit running. Always do maintenance and repairs on a cool unit. Disconnect spark plug wire to ensure the unit will not start.

FREQUENCY	MAINTENANCE REQUIRED	REFER TO:
Before Starting Engine	Fill fuel tank with fresh fuel Check oil	Page 11 Page 19
Every 10 Hours	Clean and re-oil air filter.	Page 20
1st Change at 10 Hours Every 25 Hours there after Every 25 Hours	Change oil Change oil Clean Spark Arrestor	Page 19 Page 19 Page 24
10 hours on new engine Every 50 Hours Every 50 Hours	Check rocker arm to valve clearance and adjust as required Check rocker arm to valve clearance and adjust as required Check spark plug condition and gap	Page 22-23 Page 22-23 Page 24

MAINTENANCE AND REPAIR INSTRUCTIONS

LINE INSTALLATION FOR THE SPEEDSPOOL®

Always use genuine Ryobi 0.080 inch (2.03 mm) replacement line. Line other than specified may make the engine overheat or fail.



WARNING: Never use metal-reinforced line, wire, or rope, etc. These can break off and become a dangerous projectile.

There are two methods to replace the SpeedSpool® trimming line.

- Wind the inner reel with new line
- Install a prewound inner reel

Winding the Inner Reel With New Line

NOTE: It is unnecessary to remove the bump knob to install new trimming line.

1. Cut two pieces of 0.080 inch (2.03 mm) trimming line, 10 feet (3 m) long.



WARNING: Always use the correct line length when installing trimming line on the unit. The line may not release properly if the line is too long.

2. Hold the outer spool and turn the inner reel counterclockwise to line up the arrows on the outer spool and inner reel (Fig. 17).

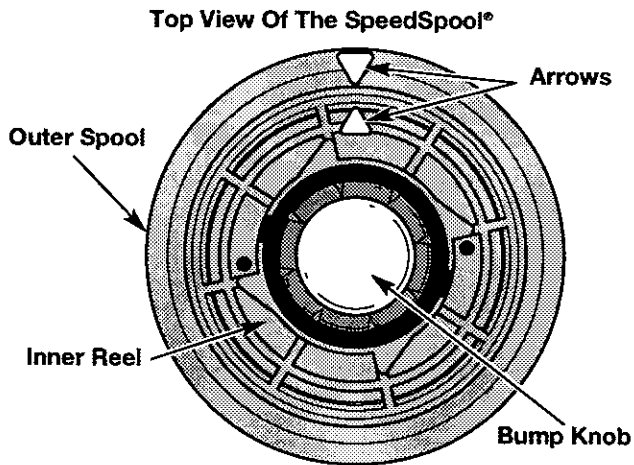

Fig. 17

3. Pull old line out of the line loading and line locking holes (Figs. 18 and 19).
4. Insert a piece of trimming line into one of the two eyelets in the outer spool. Push it up through the line loading hole in the inner reel (Fig. 18). Do not bend the line when inserting it into the eyelet.

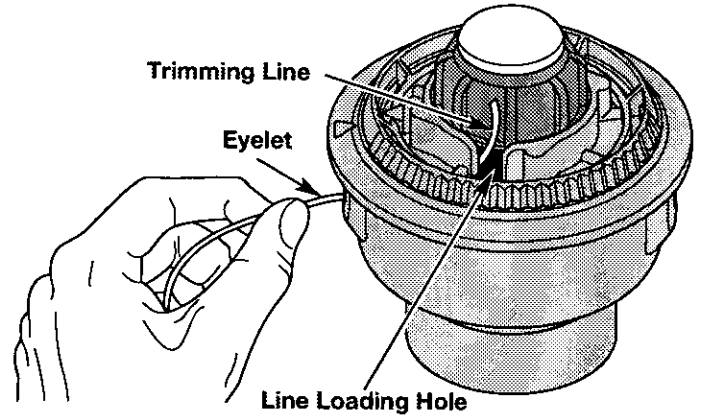

Fig. 18

5. Insert the line into the locking hole (Fig. 18). Do not push the line more than 1/2 inch (12.7 mm) into the line locking hole. When inserted correctly the line will form a small loop (Fig. 19).

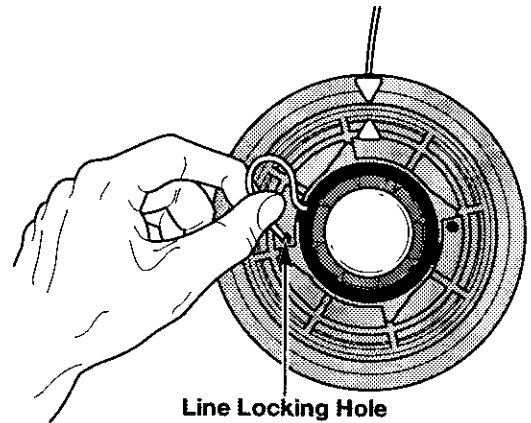

Fig. 19

6. Pull the line from the outer spool until the line is tight against the inner reel (Fig. 20).

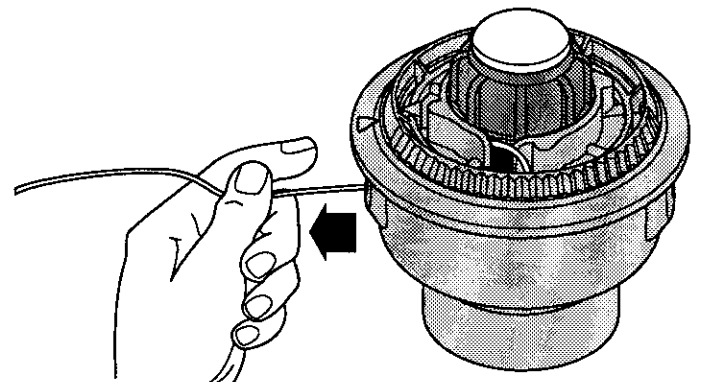

Fig. 20

MAINTENANCE AND REPAIR INSTRUCTIONS

7. Repeat procedures 4-6 with the second piece of line.
8. Hold the outer spool. Wind the inner reel counterclockwise until approximately four (4) inches (102 mm) of line remain (Fig. 21).

NOTE: Do not wind the inner reel before installing the second piece of line.

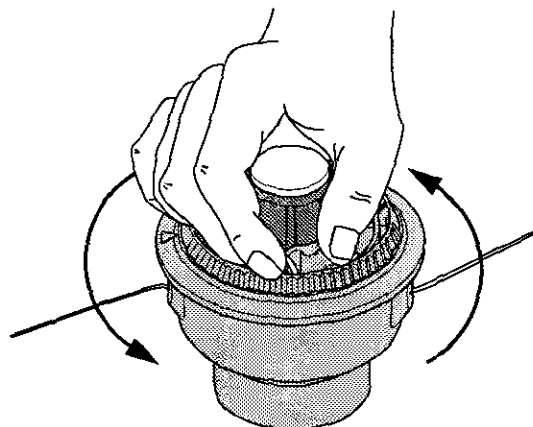

Fig. 21

9. If winding the line becomes difficult or the line jams, pull the ends of the line from the spool (Fig. 22). Continue winding the inner reel counterclockwise.

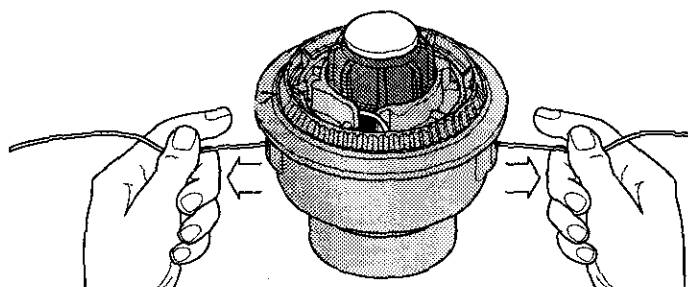

Fig. 22

INSTALLING A PREWOUND REEL

1. Turn the Bump Knob counterclockwise and remove the bump knob, spring, and foam seal (Fig. 23).

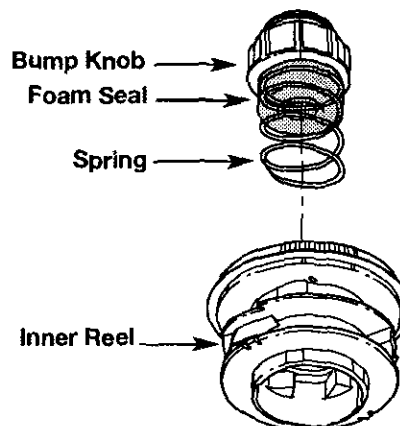

Fig. 23

2. Pull the old inner reel with existing line from the outer spool.
3. Insert the ends of the prewound inner reel line into the outer spool eyelets (Fig. 24). Push the new inner reel, arrow side up, into the outer spool.

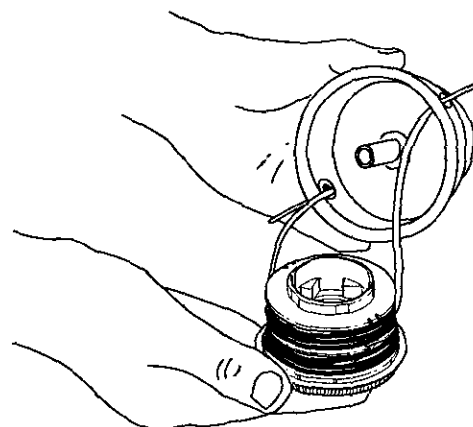

Fig. 24

4. Hold the inner reel in place and install the bump knob, spring and foam seal. Press down and turn the bump knob clockwise. Grasp the ends and pull firmly to release the line from the holding slots in the inner reel (Fig. 22).

Releasing the Inner Reel

If the SpeedSpool® does not release line correctly, pull the ends of the line firmly from the spool (Fig. 22). If this does not release line, follow the **Cleaning the SpeedSpool®** instructions.

MAINTENANCE AND REPAIR INSTRUCTIONS

CLEANING THE SPEEDSPOOL®

Cleaning the SpeedSpool® may be necessary,

- To remove jammed or excess line,
 - If the SpeedSpool® becomes difficult to wind or does not operate correctly when bumping the head on the ground,
1. Hold the outer spool, and unscrew the bump knob counterclockwise (Fig. 25).

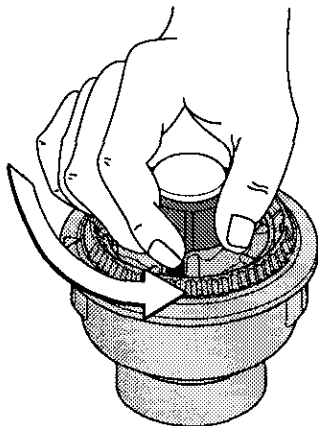

Fig. 25

2. Pull out the bump knob, spring, and foam seal (Fig. 23, Pg. 17).
3. Pull the inner reel with existing line from the outer spool (Fig. 23, Pg. 17).
4. Remove any existing line from the inner reel before cleaning. Remove any debris or grass from the knob, spring, inner reel, and foam seal. Wash the inner reel with warm soapy water (Fig. 26).

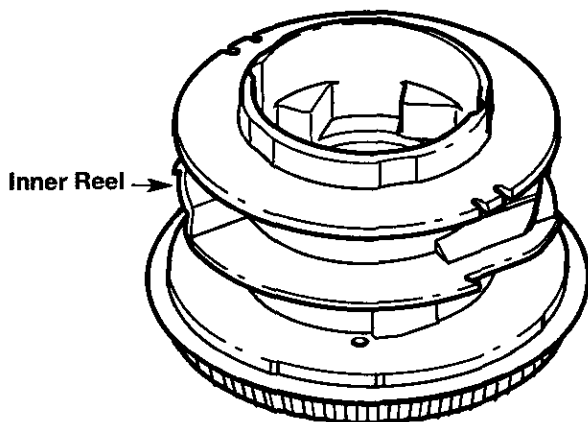

Fig. 26

5. Clean the shaft and the inner surface of the outer spool. To clean the shaft underneath the plunger, press down on the plunger (Fig. 27). Remove any dirt or debris from the shaft.

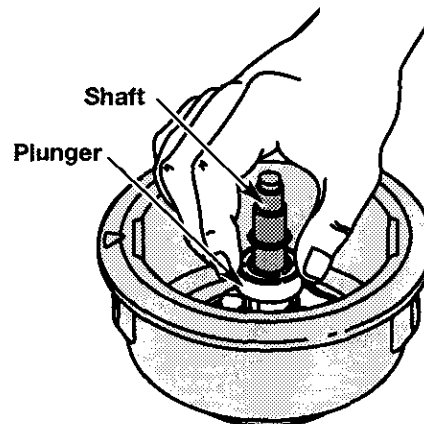

Fig. 27

NOTE: The inner reel must be totally dry before reinstalling it into the outer spool. Do not lubricate the inner reel or outer spool assembly.

6. Place the inner reel into the outer spool.
7. Place the bump knob, spring, and foam seal into the inner reel (Fig. 23, Pg. 17).
8. Press the bump knob down and tighten clockwise.
9. Install new line as described in **Line Installation for the SpeedSpool®** Pg. 16.

SPEEDSPOOL® REPLACEMENT PARTS

Replacement Line	181472
Replacement Line Cartridge	181460
Inner Reel Spring	181465
Foam Seal	181467
Inner Reel	181460
Bump Head Knob Assembly	181468
(Bump Head, Inner Reel, Spring,)	

These SpeedSpool® replacement parts can be purchased from your local authorized dealer.

MAINTENANCE AND REPAIR INSTRUCTIONS

CHECKING THE OIL LEVEL



CAUTION: To prevent extensive engine wear and damage to the unit, always maintain the proper oil level in the crankcase. Never operate the unit with the oil level below the bottom of the dipstick.

The importance of checking and maintaining the proper oil level in the crankcase cannot be overemphasized. Check oil before each use:

1. Stop engine and allow oil to drain into the crankcase.
2. Place the unit on a flat, level surface to get a proper oil level reading.
3. Keep dirt, grass clippings, etc., out of the engine. Clean the area around the oil fill plug/dipstick before removing it.
4. Remove the oil fill plug/dipstick and wipe off oil. Reinsert it all the way back in.
5. Remove the oil fill plug/dipstick and check oil level. Oil should be up to the top of the dipstick (Fig. 28).

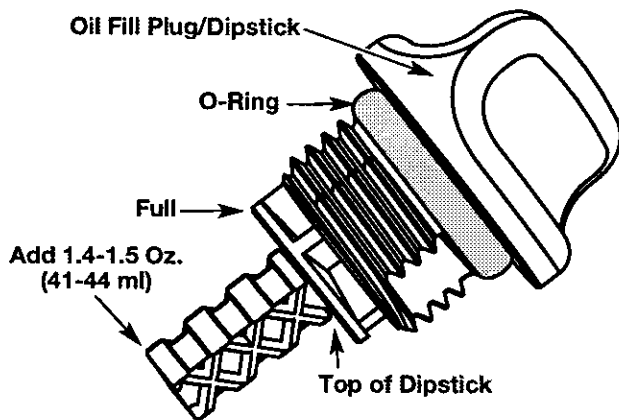

Fig. 28

6. If the level is low, add a small amount of oil to the oil fill hole and recheck (Fig. 29). Repeat until the oil level reaches the top of the dipstick.

NOTE: Do not overfill the unit.

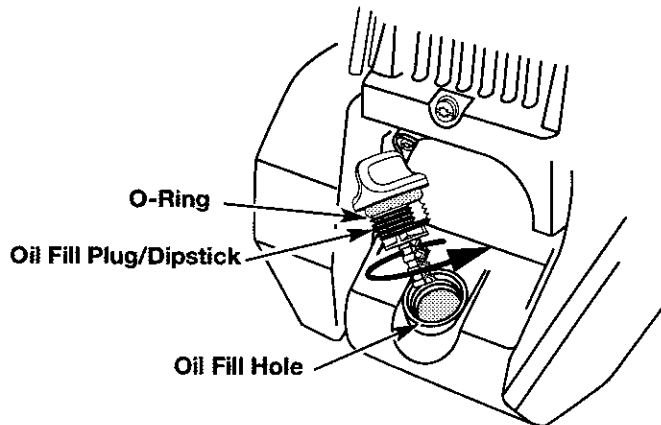

Fig. 29

NOTE: Make sure the O-ring is in place on the oil fill plug/dipstick when checking and changing the oil (Fig. 29).

CHANGING THE OIL

For a new engine, change the oil after the first 10 hours of operation. Change the oil while the engine is still warm. The oil will flow freely and carry away more impurities.



CAUTION: Wear gloves to prevent injury when handling the unit.

1. Unplug spark plug boot to eliminate starting.
2. Remove the oil fill plug/dipstick.
3. Pour the oil out of the oil fill hole and into a container by tipping the unit to a vertical position (Fig. 30). Allow ample time for complete drainage.

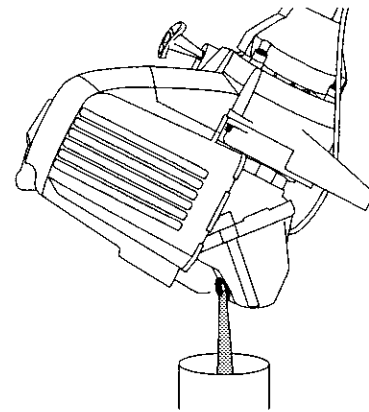

Fig. 30

4. Wipe up any oil residue on the unit and clean up any oil that may have spilled. Dispose of the oil according to Federal, State and local regulations.
5. Refill the crankcase with 3.4 fluid ounce (100 ml) of SAE 30 SF, SG, SH oil.

NOTE: Use the bottle and spout saved from initial use to measure the correct amount. 3.4 ounce (100 ml) is approximately to the top of the label on the bottle (Fig. 31). Check the level with the dipstick. If the level is low, add a small amount of oil and recheck (Fig. 28). Do not overfill.

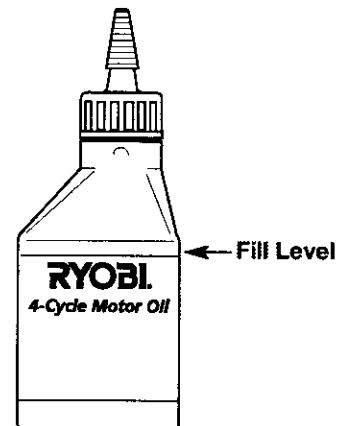

Fig. 31

6. Replace the oil fill plug/dipstick.
7. Reconnect spark plug boot.

MAINTENANCE AND REPAIR INSTRUCTIONS

AIR FILTER MAINTENANCE

Cleaning the Air Filter



WARNING: To avoid serious personal injury, always turn your trimmer off and allow it to cool before you clean or do any maintenance on it.

Clean and re-oil the air filter every 10 hours of operation. It is an important item to maintain. Not maintaining the air filter will **VOID** the warranty.

1. Open the air filter cover. Push the tab on the right side of the cover in, pull the air filter cover out and to the left (Fig. 32).

NOTE: It may be necessary to remove the fuel cap to completely remove the air filter cover

2. Remove the air filter (Fig. 32).

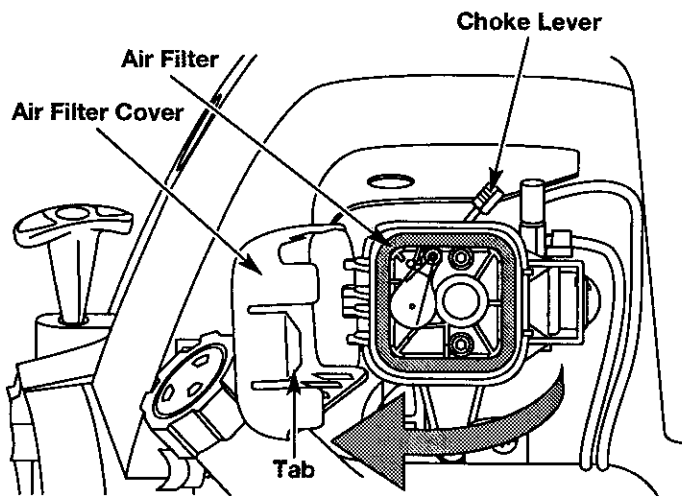

Fig. 32

3. Wash the filter in detergent and water (Fig. 33). Rinse the filter thoroughly and allow it to dry.

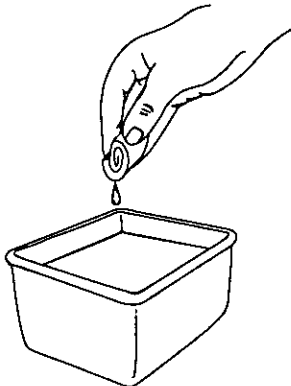

Fig. 33

4. Apply enough clean SAE 30 motor oil to lightly coat the filter (Fig. 34).

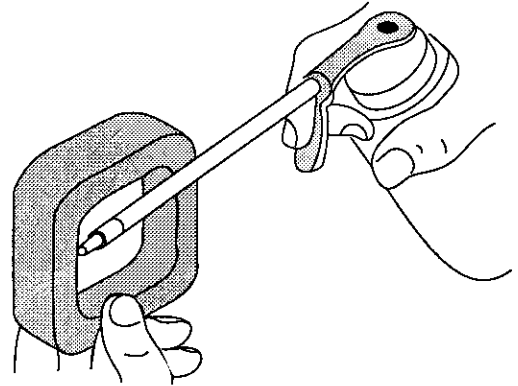

Fig. 34

5. Squeeze the filter to spread and remove excess oil (Fig. 35).

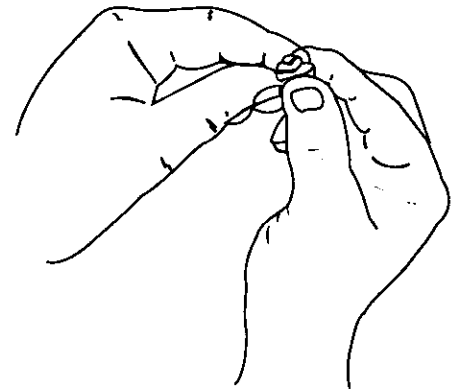

Fig. 35

6. Replace the filter (Fig. 36).

NOTE: If the unit is operated without the air filter, you will **VOID** the warranty.

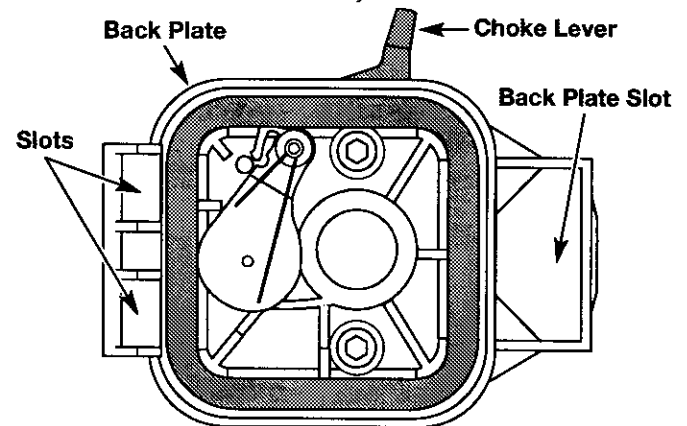

Fig. 36

7. Reinstall the air filter cover. Position the hooks on the left side of the air filter cover into the slots at the left side of the back plate (Fig. 36).

NOTE: It may be necessary to remove the fuel cap to reinstall the air filter cover

8. Swing the cover to the right until the tab on the air filter cover snaps into place in the slot on the back plate (Fig. 36).
9. Replace the fuel cap, if removed.

MAINTENANCE AND REPAIR INSTRUCTIONS

CARBURETOR ADJUSTMENT

The idle speed of the engine is adjustable. An idle adjustment screw is reached through a hole in the top of the engine cover (Fig 37).

NOTE: Careless adjustments can seriously damage your unit. An authorized service dealer should make carburetor adjustments.

Check Fuel

Old fuel is usually the main reason for the unit not running properly. Drain and refill the tank with clean, fresh unleaded fuel prior to doing any adjustments. Refer to **Oil and Fuel Information**.

Clean Air Filter

The condition of the air filter is important to the operation of the unit. A dirty air filter will restrict air flow and change the air/fuel mixture. This is often mistaken for an out of adjustment carburetor. Check the condition of the air filter before adjusting the idle speed screw. Refer to **Air Filter Maintenance**.

Adjust Idle Speed Screw



WARNING: The cutting attachment may be spinning during idle speed adjustment. Wear protective clothing and observe all safety instructions to prevent serious personal injury.

If after checking the fuel and cleaning the air filter the engine still will not idle, adjust the idle speed screw as follows.

1. Start the engine and let it run at a high idle for a minute to warm up.
2. Release the throttle trigger and let the engine idle. If the engine stops, insert a small phillips or flat blade screwdriver into the hole in the engine cover (Fig. 37). Turn the idle speed screw in, clockwise, 1/8 of a turn at a time (as needed) until the engine idles smoothly.

NOTE: The cutting attachment should not rotate when the engine idles.

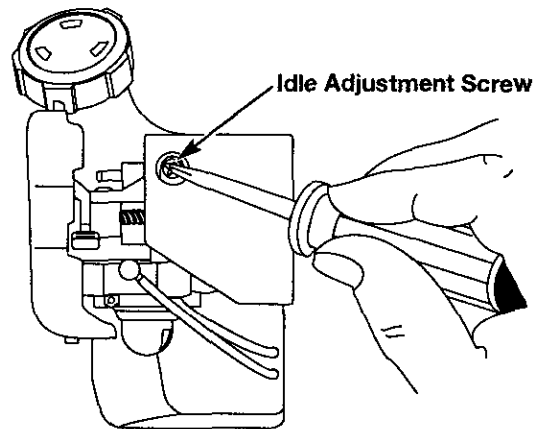

Fig. 37

3. If the cutting attachment rotates when the engine idles, turn the idle speed screw counterclockwise 1/8 of a turn at a time (as needed), to reduce idle speed.

Checking the fuel, cleaning the air filter, and adjusting the idle speed screw should solve most engine problems.

If not and:

- The engine will not idle,
- The engine hesitates or stalls on acceleration,
- There is a loss of engine power,

have the carburetor adjusted by an authorized service dealer.



WARNING: When the unit is turned off make sure the cutting attachment has stopped before the unit is set down to prevent serious personal injury.

MAINTENANCE AND REPAIR INSTRUCTIONS

ROCKER ARM CLEARANCE

This requires disassembly of the engine. If you feel unsure or unqualified to perform this, take the unit to an authorized service center.

NOTE: Inspect the valve to rocker arm clearance with a feeler gauge after the first 10 hours of operation and then every 50 hours of operation thereafter.

- The engine must be cold when checking or adjusting the valve clearance.
 - This task should be performed inside, in a clean, dust free area.
1. Remove the muffler cover by pressing down on the corner with a flat blade screwdriver (Fig. 38). Slide the notches on the sides of the muffler cover over the tabs on the engine cover and remove

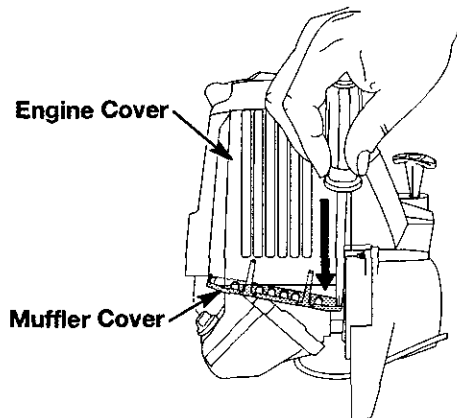

Fig. 38

2. Remove the two (2) screws on top of the engine cover with a phillips screwdriver (Fig. 39).

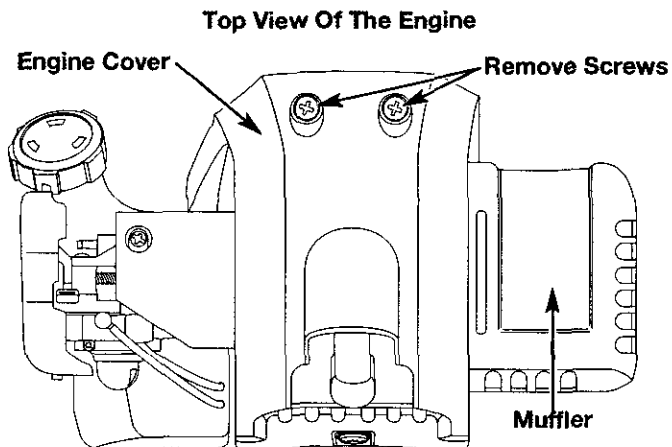

Fig. 39

3. Remove the screw behind the engine cover (Fig. 40).

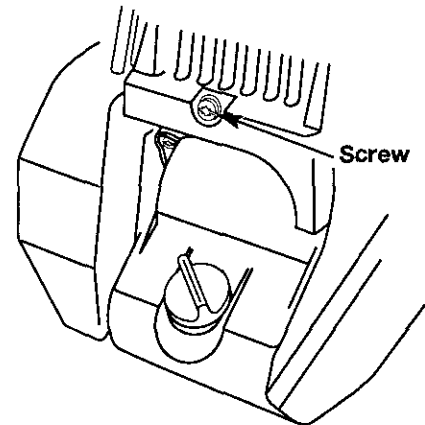

Fig. 40

4. Disconnect the spark plug wire.
5. Clean dirt from around the spark plug. Remove the spark plug from the cylinder head by turning a 5/8 in. socket counterclockwise.
6. Remove the engine cover (Fig. 39).
7. Clean dirt from around the rocker arm cover. Remove the screw holding the rocker arm cover with a large flat blade screwdriver or Torx T25 bit (Fig. 41). Remove the rocker arm cover and gasket.

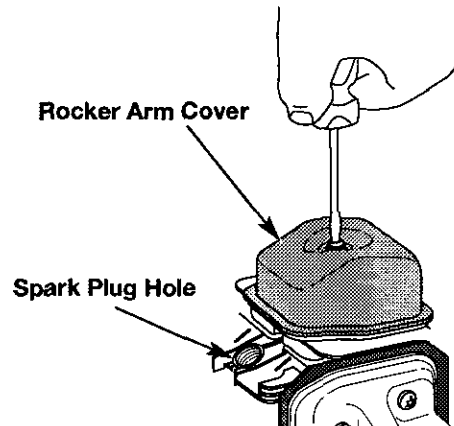

Fig. 41

8. Pull the starter rope slowly to bring the piston to the top of its travel, (known as top dead center). Check that:
 - The piston is at the top of its travel while looking in the spark plug hole (Fig. 41).
 - Both rocker arms move freely, and both valves are closed.

If not, repeat this step.

MAINTENANCE AND REPAIR INSTRUCTIONS

9. Slide the feeler gauge between the rocker arm and the valve return spring. Measure the clearance between the valve stem and rocker arm (Fig 42). Do both intake and exhaust valves.

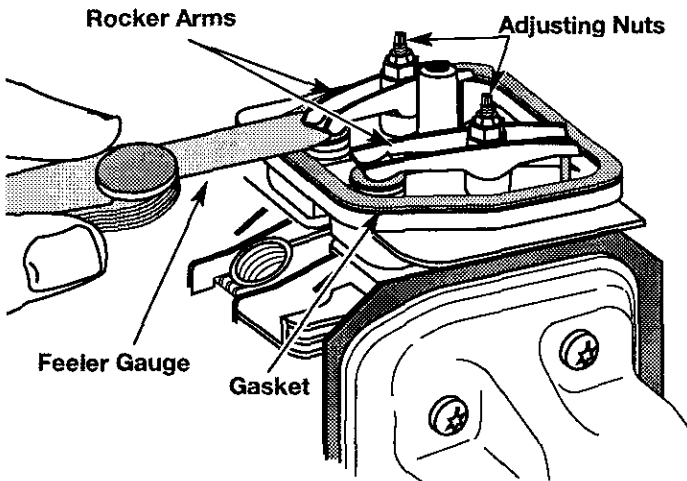

Fig. 42

The recommended clearance for both intake and exhaust is .003 – .006 in. (.076 – 0.152 mm). Use a standard automotive .005 in. (0.127 mm) feeler gauge. The feeler gauge should slide between the rocker arm and valve stem with a slight amount of resistance, without binding (Fig. 43).

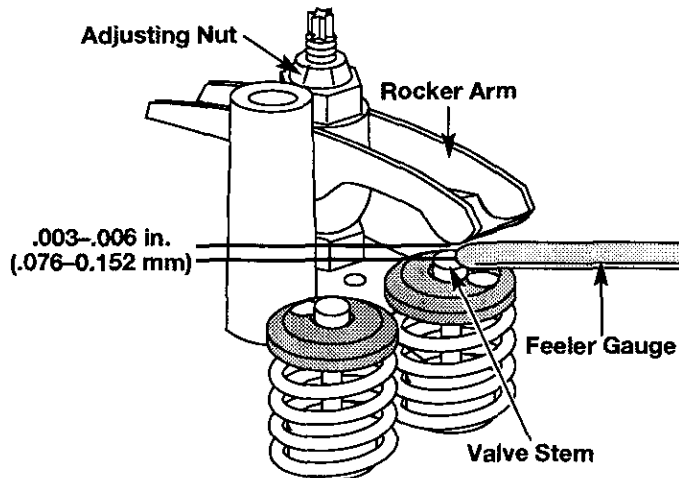

Fig. 43

10. If the clearance is not within specification:
- Turn the adjusting nut using a 5/16 inch (8 mm) wrench or nut driver (Fig. 42).
 - To increase clearance, turn the adjusting nut counterclockwise.
 - To decrease clearance, turn the adjusting nut clockwise.
 - Recheck both clearances, and adjust as necessary.
11. Reinstall the rocker arm cover using a new gasket. Torque the screw to 20–30 in·lb (2.2–3.4 N·m).
- NOTE:** A rocker arm cover gasket, Part # 182099 can be purchased from your local authorized dealer.
12. Reinstall the engine cover. Check alignment of the cover before tightening the screws. Tighten screws.
13. Replace the muffler cover. Slip the long tabs on the muffler cover into the engine cover. Slide the notches on the side of the muffler cover over the tabs on the engine cover and snap into place (Fig. 38).
14. Check the spark plug and reinstall. See **Replacing the Spark Plug**.
15. Replace the spark plug wire.

MAINTENANCE AND REPAIR INSTRUCTIONS

REPLACING THE SPARK PLUG

Use only genuine Ryobi spark plugs. The correct air gap is 0.025 in. (0.655 mm.). Remove the plug after every 50 hours of operation and check its condition.

1. Stop the engine and allow it to cool. Grasp the plug wire firmly and pull the cap from the spark plug.
2. Clean dirt from around the spark plug. Remove the spark plug from the cylinder head by turning a 5/8 in. socket counterclockwise.
3. Replace cracked, fouled or dirty spark plug. Set the air gap at 0.025 in. (0.655 mm.) using a feeler gauge (Fig. 44).

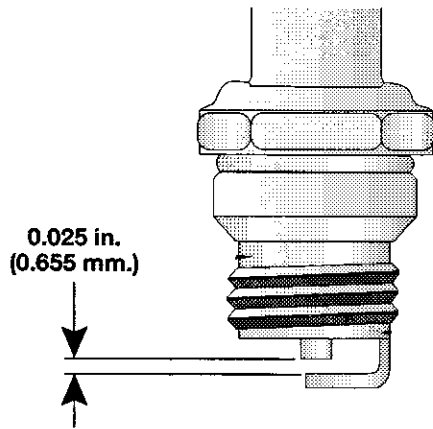

Fig. 44



CAUTION: Do not sand blast, scrape, or clean electrodes. Grit in the engine could damage the cylinder.

4. Install a correctly gaped spark plug in the cylinder head. Tighten by turning the 5/8 in. socket clockwise until snug.

If using a torque wrench torque to;

110-120 in. • lb. (12.3-13.5 N•m).

Do not over tighten.

NOTE: A replacement spark plug Part # 180852 can be purchased from your local authorized dealer.

SPARK ARRESTOR MAINTENANCE

1. Remove the muffler cover. See **Rocker Arm Clearance**, Pg. 22.
2. With a flat blade screwdriver or Torx T20 bit, remove the screw attaching the spark arrestor cover to the muffler (Fig. 45).

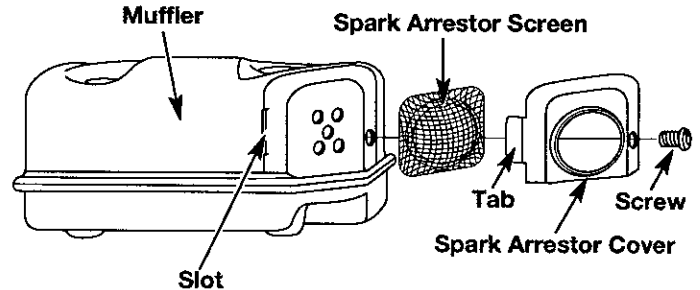

Fig. 45

3. Pull the tab on the spark arrestor cover out of the muffler. Remove the spark arrestor cover.
4. Remove the spark arrestor screen from the spark arrestor cover.
5. Clean the spark arrestor screen with a wire brush, or replace.
6. Reinstall the spark arrestor screen, spark arrestor cover, and screw.

NOTE: A replacement spark arrestor screen Part # 180890 can be purchased from your local authorized dealer.

ACCESSORIES/REPLACEMENT PARTS

4-Cycle Oil	181786
Oil Fill Plug / Dipstick	182378
Spark Plug	180852
Spark Arrestor Screen	180890
Replacement Line Cartridge	181460
Inner Reel Spring	181465
Bump Head Knob Assembly	181468
Fuel Cap	181083
Shoulder Harness	682075
Click-Link Coupler	181616

CLEANING AND STORAGE

CLEANING



WARNING: To avoid serious personal injury, always turn your trimmer off and allow it to cool before you clean or do any maintenance on it.

Use a small brush to clean off the outside of the unit. Do not use strong detergents. Household cleaners that contain aromatic oils such as pine and lemon, and such as kerosene, can damage plastic housing or handle. Wipe off any moisture with a soft cloth.

STORAGE

- Never store the unit with gasoline in the tank where fumes may reach an open flame or spark.
- Allow the engine to cool before storing.
- Store the unit locked up to prevent unauthorized use or damage.
- Store the unit in a dry, well ventilated area.
- Store the unit out of the reach of children.

Store the unit in one of three (3) positions:

1. The unit hanging by the cutting attachment end.
2. The unit hanging by the engine.
3. The unit setting upright on the cutting attachment shield and engine feet.

LONG TERM STORAGE

If the unit will be stored for an extended time,

1. Drain all gasoline from the gas tank into a container. Do not use gas that has been stored for more than 60 days. Dispose of the old gasoline in accordance to Federal, State, and Local regulations.
2. Start the engine and allow it to run until it stalls. This ensures that all gasoline has been drained from the carburetor.
3. Allow the engine to cool. Remove the spark plug and put 1 oz. (30 ml) of high quality motor oil into the cylinder. Pull the starter rope slowly to distribute the oil. Reinstall the spark plug.

NOTE: Remove the spark plug and drain all of the oil from the cylinder before attempting to start the trimmer after storage.

4. Change the oil. See **Changing the Oil**, Pg. 19. Dispose of the old oil in accordance to Federal, State, and Local regulations.
5. Thoroughly clean the unit and inspect for any loose or damaged parts. Repair or replace damaged parts and tighten loose screws, nuts or bolts. The unit is ready for storage.

TRANSPORTING

- Allow the engine to cool before transporting.
- Secure the unit while transporting.
- Drain the gas tank before transporting.
- Tighten gas cap before transporting.

TROUBLESHOOTING

ENGINE WILL NOT START

CAUSE

Ignition switch is OFF
Empty fuel tank
Primer bulb wasn't pressed enough
Engine flooded

Old Gasoline
Fouled spark plug

ACTION

Turn switch to ON
Fill fuel tank
Press primer bulb fully and slowly 5-7 times
Use starting procedure with choke lever in the RUN position, Pg. 12
Drain fuel tank / Add fresh Gasoline
Replace or clean the spark plug

ENGINE WILL NOT IDLE

CAUSE

Air Filter is Plugged
Old Gasoline
Improper carburetor adjustment

ACTION

Replace or clean the air filter
Drain fuel tank / Add fresh Gasoline
Adjust per instruction Pg. 20

ENGINE WILL NOT ACCELERATE

CAUSE

Old Gasoline
Improper carburetor adjustment

Cutting head bound with grass
Dirty air filter
Clogged Spark Arrestor Screen

ACTION

Drain gas tank / Add fresh Gasoline
Take to an authorized service dealer for carburetor adjustment
Stop the engine and clean the cutting attachment
Clean or replace the air filter
Clean or Replace. See Pg. 24

ENGINE LACKS POWER OR STALLS WHEN CUTTING

CAUSE

Old Gasoline
Improper carburetor adjustment

Clogged Spark Arrestor Screen

ACTION

Drain fuel tank / Add fresh Gasoline
Take to an authorized service dealer for carburetor adjustment
Clean or Replace. See Pg. 24

CUTTING HEAD WILL NOT ADVANCE LINE

CAUSE

Cutting head bound with grass
Cutting head out of line
Inner reel bound up
Cutting head dirty
Line welded

Line twisted when refilled
Not enough line is exposed

ACTION

Stop the engine and clean cutting attachment
Refill with new line
Replace the inner reel
Clean inner reel and outer spool
Disassemble, remove the welded section and rewind the line
Disassemble and rewind the line
Push the Bump Knob and pull out line until 4 inches (102 mm) of line is outside of the cutting attachment

CUTTING LINE ADVANCES UNCONTROLLABLY

CAUSE

Oil in cutting head

ACTION

Clean the cutting attachment

If further assistance is required, contact your authorized service dealer.

SPECIFICATIONS

ENGINE

ENGINE

Engine Type	Air-Cooled, 4-Cycle
Displacement	1.6 cu. in. (26.2 cc)
Clutch Type	Centrifugal
Operating RPM	6,800-7,800 rpm
Idle Speed RPM	2,800 rpm
Ignition Type	Electronic
Ignition Switch	Rocker Switch
Valve clearance (intake and exhaust)	.003-.006 in. (.076-.0152 mm)
Spark Plug Gap	0.025 inch (0.655 mm)
Lubrication	SAE 30 Oil
Crankcase Oil Capacity	3.4 oz (100 ml)
Fuel	Unleaded
Carburetor	Diaphragm, All-Position
Starter	Auto Rewind
Muffler	Baffled with Guard
Throttle	Manual Spring Return
Fuel Tank Capacity	20 oz (591 ml)
Fuel Tank	HD Polyethylene

DRIVE SHAFT & CUTTING ATTACHMENT

Drive Shaft Housing	Aluminum Tube (Click-Link)
Throttle Control	Finger-Tip Trigger
Unit Weight (No Fuel, with J-handle, Cutting attachment shield and Cutting attachment)	13.5 lbs (6.13 kg)
Cutting Mechanism	Dual String Cutting Head
Line Spool	Bump Line Releaser
Line Spool Diameter	3 inches (76.2 mm)
Trimming Line Diameter	0.080 inches (2.03 mm)
Cutting Path Diameter	15 inches (38.1 cm)

NOTES

CALIFORNIA EMISSION CONTROL WARRANTY STATEMENT YOUR WARRANTY RIGHTS AND OBLIGATIONS

The California Air Resources Board and Ryobi Outdoor Products (ROP), are pleased to explain the emission control system warranty on your 2000 and later small off-road engine. In California, new small off-road engines must be designed, built and equipped to meet the State's stringent anti-smog standards. ROP must warrant the emission control system on your small off-road engine for the periods of time listed below provided there has been no abuse, neglect or improper maintenance of your small off-road engine.

Your emission control system may include parts such as the carburetor or fuel injection system, the ignition system, and catalytic converter. Also included may be hoses, belts, connectors and other emission-related assemblies.

Where a warrantable condition exists, ROP will repair your small off-road engine at no cost to you including diagnosis, parts and labor.

The 2000 and later small off-road engines are warranted for two years. If any emission-related part on your engine is defective, the part will be repaired or replaced by ROP.

OWNER'S WARRANTY RESPONSIBILITIES:

- As the small off-road engine owner, you are responsible for the performance of the required maintenance listed in your operator's manual. ROP recommends that you retain all receipts covering maintenance on your small off-road engine, but ROP cannot deny warranty solely for the lack of receipts or for your failure to ensure the performance of all scheduled maintenance.
- As the small off-road engine owner, you should however be aware that ROP may deny you warranty coverage if your small off-road engine or a part has failed due to abuse, neglect, improper maintenance or unapproved modifications.
- You are responsible for presenting your small off-road engine to a Ryobi Authorized Service Center as soon as a problem exists. The warranty repairs should be completed in a reasonable amount of time, not to exceed 30 days.

If you have any questions regarding your warranty rights and responsibilities, you should call 1-800-345-8746.

MANUFACTURER'S WARRANTY COVERAGE:

- The warranty period begins on the date the engine or equipment is delivered to the retail purchaser.
- The manufacturer warrants to the initial owner and each subsequent purchaser, that the engine is free from defects in material and workmanship which cause the failure of a warranted part for a period of two years.
- Repair or replacement of warranted part will be performed at no charge to the owner at an Authorized Ryobi Service Center. For the nearest location, please contact Ryobi at: 1-800-345-8746.
- Any warranted part which is not scheduled for replacement, as required maintenance which is scheduled only for regular inspection to the effect of "Repair or replace as necessary" is warranted for the warranty period. Any warranted part which is scheduled for replacement as required maintenance will be warranted for the period of time up to the first scheduled replacement point for that part.
- The owner will not be charged for diagnostic labor which leads to the determination that a warranted part is defective, if the diagnostic work is performed at an Authorized Ryobi Service Center.
- The manufacturer is liable for damages to other engine components caused by the failure of a warranted part still under warranty.
- Failures caused by abuse, neglect or improper maintenance are not covered under warranty.
- The use of add-on or modified parts can be grounds for disallowing a warranty claim. The manufacturer is not liable to cover failures or warranted parts caused by the use of add-on or modified parts.
- In order to file a claim, go to your nearest Authorized Ryobi Service Center. Warranty services or repairs will be provided at all Authorized Ryobi Service Centers.
- Any manufacturer approved replacement part may be used in the performance of any warranty maintenance or repair of emission related parts and will be provided without charge to the owner. Any replacement part that is equivalent in performance or durability may be used in non-warranty maintenance or repair and will not reduce the warranty obligations of the manufacturer.
- The following components are included in the emission related warranty of the engine, air filter, carburetor, primer, fuel lines, fuel pick up/fuel filter, ignition module, spark plug and muffler.

LIMITED TWO-YEAR WARRANTY

RYOBI OUTDOOR PRODUCTS warrants each new RYOBI Product for two (2) years according to the following terms.

This warranty extends to the original retail purchaser only and commences on the date of original retail purchase.

Any part of the RYOBI Product manufactured or supplied by RYOBI and found in the reasonable judgement of RYOBI to be defective in material or workmanship will be repaired or replaced by an authorized RYOBI service dealer without charge for parts and labor.

The RYOBI Product including any defective part must be returned to an authorized service dealer within the warranty period. The expense of delivering the RYOBI Product to the dealer for warranty work and the expense of returning it back to the owner after repair or replacement will be paid for by the owner. RYOBI's responsibility in respect to claims is limited to making the required repairs or replacements and no claim of breach of warranty shall be cause for cancellation or rescission of the contract of sale of any RYOBI Product. Proof of purchase will be required by the dealer to substantiate any warranty claim. All warranty work must be performed by an authorized RYOBI service dealer.

This warranty is limited to ninety (90) days from the date of original retail purchase for any RYOBI Product that is used for rental or commercial purposes, or any other income-producing purpose.

This warranty does not cover any RYOBI Product that has been subject to misuse, neglect, negligence, or accident, or that has been operated in any way contrary to the operating instructions as specified in the RYOBI Operator's Manual. This warranty does not apply to any damage to the RYOBI Product that is the result of improper maintenance or to any RYOBI Product that has been altered or modified so as to adversely affect the product's operation, performance or durability or that has been altered or modified so as to change its intended use. The warranty does not extend to repairs made necessary by normal wear or by the use of parts or accessories which are either incompatible with the RYOBI Product or adversely affect its operation, performance or durability.

In addition, this warranty does not cover:

- A. Tune-ups - Spark Plugs, Carburetor Adjustments, Filters
- B. Wear items - Bump Knobs, Outer Spools, Cutting Line, Inner Reels, Starter Pulley, Starter Ropes, Drive Belts

RYOBI reserves the right to change or improve the design of any RYOBI Product without assuming any obligation to modify any product previously manufactured.

ALL IMPLIED WARRANTIES ARE LIMITED IN DURATION TO THE TWO (2) YEAR WARRANTY PERIOD OR NINETY (90) DAYS FOR PRODUCTS USED FOR ANY COMMERCIAL PURPOSE. ACCORDINGLY, ANY SUCH IMPLIED WARRANTIES INCLUDING MERCHANTABILITY, FITNESS FOR A PARTICULAR PURPOSE, OR OTHERWISE, ARE DISCLAIMED IN THEIR ENTIRETY AFTER THE EXPIRATION OF THE APPROPRIATE TWO-YEAR OR NINETY DAY WARRANTY PERIOD. RYOBI'S OBLIGATION UNDER THIS WARRANTY, IS STRICTLY AND EXCLUSIVELY LIMITED TO THE REPAIR OR REPLACEMENT OF DEFECTIVE PARTS, AND ROP DOES NOT ASSUME OR AUTHORIZE ANYONE TO ASSUME FOR THEM ANY OTHER OBLIGATION. SOME STATES DO NOT ALLOW LIMITATIONS ON HOW LONG AN IMPLIED WARRANTY LASTS, SO THE ABOVE LIMITATION MAY NOT APPLY TO YOU.

RYOBI ASSUMES NO RESPONSIBILITY FOR INCIDENTAL, CONSEQUENTIAL OR OTHER DAMAGES INCLUDING, BUT NOT LIMITED TO EXPENSE OF RETURNING THE RYOBI PRODUCT TO AN AUTHORIZED SERVICE DEALER AND EXPENSE OF DELIVERING IT BACK TO THE OWNER, MECHANIC'S TRAVEL TIME, TELEPHONE OR TELEGRAM CHARGES, RENTAL OF A LIKE PRODUCT DURING THE TIME WARRANTY SERVICE IS BEING PERFORMED, TRAVEL, LOSS OR DAMAGE TO PERSONAL PROPERTY, LOSS OF REVENUE, LOSS OF USE OF THE PRODUCT, LOSS OF TIME, OR INCONVENIENCE. SOME STATES DO NOT ALLOW THE EXCLUSION OR LIMITATION OF INCIDENTAL OR CONSEQUENTIAL DAMAGES, SO THE ABOVE LIMITATION OR EXCLUSION MAY NOT APPLY TO YOU.

This warranty gives you specific legal rights, and you may also have other rights which vary from state to state.

This warranty applies to all RYOBI Products manufactured by RYOBI and sold in the United States and Canada.

To locate your nearest service dealer dial 1-800-345-8746 in the United States or 1-800-265-6778 in Canada.

RYOBI®

RYOBI OUTDOOR PRODUCTS

550 N. 54th Street
Chandler, AZ 85226 U.S.A.

RYOBI CANADA INC.

275 Industrial Rd
Cambridge, Ontario N1R 6K2 CANADA

SAVE THESE INSTRUCTIONS FOR FUTURE REFERENCE.

FOR QUESTIONS CALL 1-800-345-8746 IN U.S.

OR 1-800-265-6778 IN CANADA